

**SPECIAL LINE-UP**  
**PRODUCT**  
**SPECIFICATION SHEET**

**SOLUM**

# Newton Nano 1.3 inch

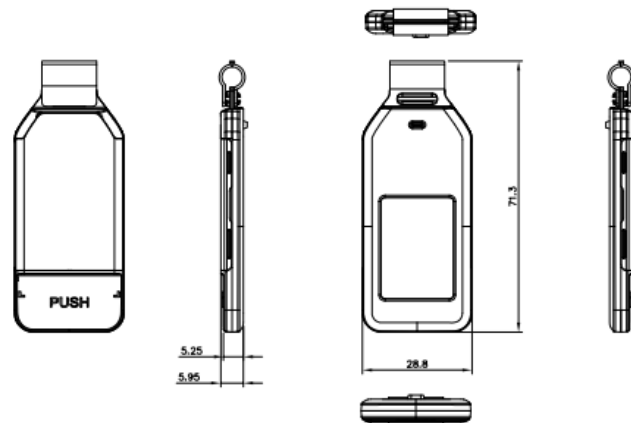

<b>MODEL</b>	EL013HEWRD/WWW
<b>DIMENSION</b>	28.8 x 71.3 x 5.95 mm / 1.13 x 2.80 x 0.23 inch
<b>ACTIVE DISPLAY AREA</b>	19.44 x 27.0 mm / 0.76 x 1.06inch
<b>RESOLUTION (Pixel)</b>	144 x 200
<b>PIXEL DENSITY</b>	188dpi
<b>DISPLAY TECHNOLOGY</b>	Full Graphic E-ink Display
<b>BEZEL COLOR</b>	White
<b>PIXEL COLORS</b>	BWR
<b>VIEWING ANGLE</b>	Nearly 180°
<b>USABLE PAGES</b>	7pages
<b>OPERATING TEMPERATURE</b>	BWR(0 ~ 30°C / 32 ~ 86°F)
<b>BATTERY</b>	CR2032 x 2ea
<b>BATTERY LIFETIME</b>	Up To 3 Years (2 Update & 1 led blinking /Day)
<b>ENCRYPTION</b>	128-Bit AES
<b>COMPLIANCE</b>	CE, RoHS, FCC
<b>NFC</b>	None
<b>WATERPROOF</b>	No
<b>BUTTON</b>	1 Button
<b>LED</b>	7 Colors (Red/Green/Blue/Yellow/Cyan/Magenta/White)
<b>ESL OPERATING FREQUENCY</b>	2.4 Ghz
<b>WIRELESS FIRMWARE UPDATE</b>	Yes

※ This specification May varies depending on the installation environment and user scenario.

**[FCC Information to User]**

This equipment has been tested and found to comply with the limits for a Class B digital device, pursuant to Part 15 of the FCC Rules. These limits are designed to provide reasonable protection against harmful interference in a residential installation. This equipment generates, uses and can radiate radio frequency energy and, if not installed and used in accordance with the instructions, may cause harmful interference to radio communications. However, there is no guarantee that interference will not occur in a particular installation. If this equipment does cause harmful interference to radio or television reception, which can be determined by turning the equipment off and on, the user is encouraged to try to correct the interference by one of the following measures:

- Reorient or relocate the receiving antenna.
- Increase the separation between the equipment and receiver.
- Connect the equipment into an outlet on a circuit different from that to which the receiver is connected.
- Consult the dealer or an experienced radio/TV technician for help.

**Caution**

THE GRANTEE IS NOT RESPONSIBLE FOR ANY CHANGES OR MODIFICATIONS NOT EXPRESSLY APPROVED BY THE PARTY RESPONSIBLE FOR COMPLIANCE. SUCH MODIFICATIONS COULD VOID THE USER'S AUTHORITY TO OPERATE THE EQUIPMENT.

**IMPORTANT NOTE : FCC RF Radiation Exposure Statement**

This equipment complies with FCC RF radiation exposure limits set forth for an uncontrolled environment.

This equipment should be installed and operated with a minimum distance of 20 centimeters between the radiator and your body. This transmitter must not be co-located or operating in conjunction with any other antenna or transmitter.

This device complies with part 15 of the FCC Rules. Operation is subject to the following two conditions:

- (1) This device may not cause harmful interference, and
- (2) this device must accept any interference received, including interference that may cause undesired operation.