

APPLICATION CERTIFICATION FCC Part 15C  
On Behalf of  
Jay Trends Merchandising Inc.

Wireless Solar Audio Table  
Model No.: #0125, #0181

FCC ID: 2AFS4-TECHNO0124

Prepared for : Jay Trends Merchandising Inc.  
Address : 9600 Meilleur Street, Suite #101 Montreal H2N 2E3,  
Quebec, Canada

Prepared by : ACCURATE TECHNOLOGY CO., LTD  
Address : F1, Bldg. A&D, Chan Yuan New Material Port,  
Keyuan Rd. Science & Industry Park, Nan Shan,  
Shenzhen, Guangdong P.R. China  
Tel: (0755) 26503290  
Fax: (0755) 26503396

Report No. : ATE20170354  
Date of Original : Sep. 9-14, 2015  
Test  
Date of new : Mar. 25-Apr. 05, 2017  
Test  
Date of Report : Sep. 19, 2015  
REV.1  
Date of Report : Apr. 06, 2017  
REV.2

## TABLE OF CONTENTS

Description	Page
Test Report Certification	
<b>1. GENERAL INFORMATION .....</b>	<b>4</b>
1.1. Description of Device (EUT).....	4
1.2. Carrier Frequency of Channels .....	5
1.3. Product differentiation Description .....	6
1.4. Special Accessory and Auxiliary Equipment .....	7
1.5. Description of Test Facility .....	7
1.6. Measurement Uncertainty .....	7
<b>2. MEASURING DEVICE AND TEST EQUIPMENT .....</b>	<b>8</b>
<b>3. OPERATION OF EUT DURING TESTING .....</b>	<b>9</b>
3.1. Operating Mode .....	9
3.2. Configuration and peripherals .....	9
<b>4. TEST PROCEDURES AND RESULTS .....</b>	<b>10</b>
<b>5. POWER LINE CONDUCTED MEASUREMENT .....</b>	<b>11</b>
5.1. Block Diagram of Test Setup.....	11
5.2. Power Line Conducted Emission Measurement Limits.....	11
5.3. Configuration of EUT on Measurement .....	11
5.4. Operating Condition of EUT .....	11
5.5. Test Procedure .....	12
5.6. Power Line Conducted Emission Measurement Results .....	12
<b>6. RADIATED SPURIOUS EMISSION TEST .....</b>	<b>17</b>
6.1. Block Diagram of Test Setup.....	17
6.2. The Limit For Section 15.247(d) .....	18
6.3. Restricted bands of operation .....	19
6.4. Configuration of EUT on Measurement .....	19
6.5. Operating Condition of EUT .....	20
6.6. Test Procedure .....	20
6.7. The Field Strength of Radiation Emission Measurement Results .....	20
<b>7. ANTENNA REQUIREMENT.....</b>	<b>27</b>
7.1. The Requirement .....	27
7.2. Antenna Construction .....	27

## Test Report Certification

Applicant : Jay Trends Merchandising Inc  
EUT Description : Wireless Solar Audio Table  
Model No. : #0125, #0181

Measurement Procedure Used:

**FCC Rules and Regulations Part 15 Subpart C Section 15.247: 2016  
ANSI C63.10: 2013**

The EUT was tested according to DTS test procedure of Apr 08, 2016 KDB558074 D01 DTS Meas Guidance v03r05 for compliance to FCC 47CFR 15.247 requirements

The device described above is tested by ACCURATE TECHNOLOGY CO. LTD to determine the maximum emission levels emanating from the device. The maximum emission levels are compared to the FCC Part 15 Subpart C Section 15.247 limits. The measurement results are contained in this test report and ACCURATE TECHNOLOGY CO. LTD is assumed full responsibility for the accuracy and completeness of these measurements. Also, this report shows that the Equipment Under Test (EUT) is to be technically compliant with the FCC requirements.

This report applies to above tested sample only. This report shall not be reproduced in part without written approval of ACCURATE TECHNOLOGY CO. LTD.

Date of Original Test :	Sep. 9-14, 2015
Date of NEW Test :	Mar. 25-Apr. 05, 2017
Date of Report REV.1 :	Sep. 19, 2015
Date of Report REV.2 :	Apr. 06, 2017

Prepared by :

  
(Timing, Engineer)

Approved & Authorized Signer :

  
( Sean Liu, Manager)

## 1. GENERAL INFORMATION

### 1.1. Description of Device (EUT)

EUT	:	Wireless Solar Audio Table
Model Number	:	#0125, #0181
Bluetooth version	:	BT V4.0 Dual Mode This report is for BT V4.0 LE mode
Frequency Range	:	2402MHz-2480MHz
Number of Channels	:	40 for BT V4.0 LE 79 for BT 3.0 mode
Antenna Gain	:	0dBi
Antenna type	:	PCB Antenna
EUT Power Supply	:	DC 10V/1A
Adapter for Techno 0181	:	Model:JK100100-S04USA Input: AC 100-240V~50/60Hz 0.5A Max Out: DC 10V/1A
Modulation mode	:	GFSK for BT V4.0 LE GFSK, $\pi/4$ DQPSK, 8DPSK for BT 3.0 mode
Applicant Address	:	Jay Trends Merchandising Inc. 9600 Meilleur Street, Suite #101 Montreal H2N 2E3, Quebec, Canada
Date of sample received	:	Mar. 25, 2017
Date of Test	:	Mar. 25-Apr. 05, 2017

## 1.2. Carrier Frequency of Channels

Channel	Frequency (MHz)	Channel	Frequency (MHz)	Channel	Frequency (MHz)	Channel	Frequency (MHz)
0	2402	10	2422	20	2442	30	2462
1	2404	11	2424	21	2444	31	2464
2	2406	12	2426	22	2446	32	2466
3	2408	13	2428	23	2448	33	2468
4	2410	14	2430	24	2450	34	2470
5	2412	15	2432	25	2452	35	2472
6	2414	16	2434	26	2454	36	2474
7	2416	17	2436	27	2456	37	2476
8	2418	18	2438	28	2458	38	2478
9	2420	19	2440	29	2460	39	2480

### 1.3.Product differentiation Description

Model: #0181



Compared with the original sample(Techno 0124), The name and model of the product changed, the appearance of wooden table changed, the adapter of EUT changed, but the EUT's circuit is exactly the same. So many of the data in the report is refer to the previous report(report number: ATE20151957, ATE20151958). We have added Radiated Spurious Emission Test and Conducted Emission Test and recorded in the report.

Model: #0125



Compared with the original sample(Techno 0124), Only model and name of EUT changed, the EUT's circuit is exactly the same. After evaluation, The product does not need to be tested. the test data of EUT is a refer to the previous report(report number: ATE20151957, ATE20151958).

#### 1.4.Special Accessory and Auxiliary Equipment

N/A

#### 1.5.Description of Test Facility

EMC Lab : Accredited by TUV Rheinland Shenzhen

Listed by FCC

The Registration Number is 752051

Listed by Industry Canada

The Registration Number is 5077A-2

Accredited by China National Accreditation Committee  
for Laboratories

The Certificate Registration Number is L3193

Name of Firm : ACCURATE TECHNOLOGY CO. LTD

Site Location : F1, Bldg. A, Changyuan New Material Port, Keyuan Rd.  
Science & Industry Park, Nanshan, Shenzhen, Guangdong  
P.R. China

#### 1.6.Measurement Uncertainty

Conducted Emission Expanded Uncertainty = 2.23dB, k=2

Radiated emission expanded uncertainty = 3.08dB, k=2  
(9kHz-30MHz)

Radiated emission expanded uncertainty = 4.42dB, k=2  
(30MHz-1000MHz)

Radiated emission expanded uncertainty = 4.06dB, k=2  
(Above 1GHz)

## 2. MEASURING DEVICE AND TEST EQUIPMENT

**Table 1: List of Test and Measurement Equipment**

Kind of equipment	Manufacturer	Type	S/N	Calibrated dates	Calibrated until
EMI Test Receiver	Rohde&Schwarz	ESCS30	100307	Jan. 7, 2017	1 Year
EMI Test Receiver	Rohde&Schwarz	ESPI3	101526/003	Jan. 7, 2017	1 Year
Spectrum Analyzer	Agilent	E7405A	MY45115511	Jan. 7, 2017	1 Year
Pre-Amplifier	Rohde&Schwarz	CBLU118354 0-01	3791	Jan. 7, 2017	1 Year
Loop Antenna	Schwarzbeck	FMZB1516	1516131	Jan. 13, 2017	1 Year
Bilog Antenna	Schwarzbeck	VULB9163	9163-323	Jan. 13, 2017	1 Year
Horn Antenna	Schwarzbeck	BBHA9120D	9120D-655	Jan. 13, 2017	1 Year
Horn Antenna	Schwarzbeck	BBHA9170	9170-359	Jan. 13, 2017	1 Year
LISN	Rohde&Schwarz	ESH3-Z5	100305	Jan. 7, 2017	1 Year
LISN	Schwarzbeck	NSLK8126	8126431	Jan. 7, 2017	1 Year
Highpass Filter	Wainwright Instruments	WHKX3.6/18 G-10SS	N/A	Jan. 7, 2017	1 Year
Band Reject Filter	Wainwright Instruments	WRCG2400/2 485-2375/2510 -60/11SS	N/A	Jan. 7, 2017	1 Year

### 3. OPERATION OF EUT DURING TESTING

#### 3.1. Operating Mode

The mode is used: **BLE Transmitting mode**

Low Channel: 2402MHz

Middle Channel: 2440MHz

High Channel: 2480MHz

#### 3.2. Configuration and peripherals

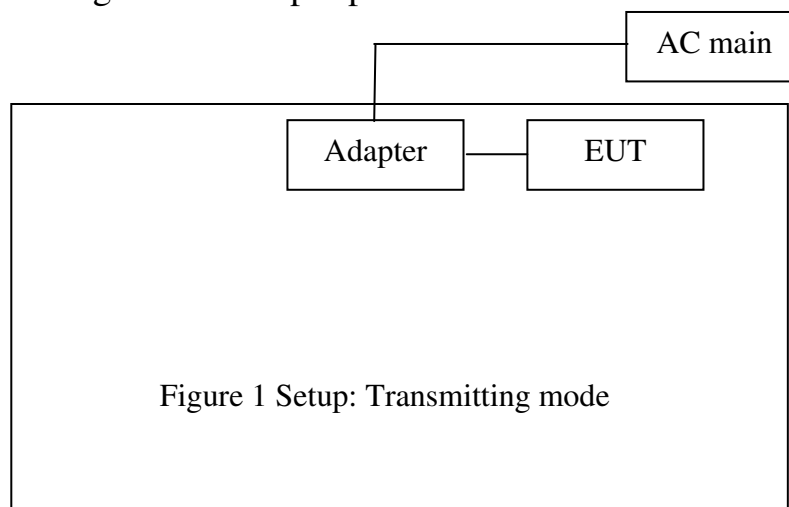

#### 4. TEST PROCEDURES AND RESULTS

<b>FCC Rules</b>	<b>Description of Test</b>	<b>Result</b>
Section 15.247(d) Section 15.209	Radiated Spurious Emission Test	Compliant
Section 15.207	AC Power Line Conducted Emission Test	Compliant
Section 15.203	Antenna Requirement	Compliant

## 5. POWER LINE CONDUCTED MEASUREMENT

### 5.1. Block Diagram of Test Setup

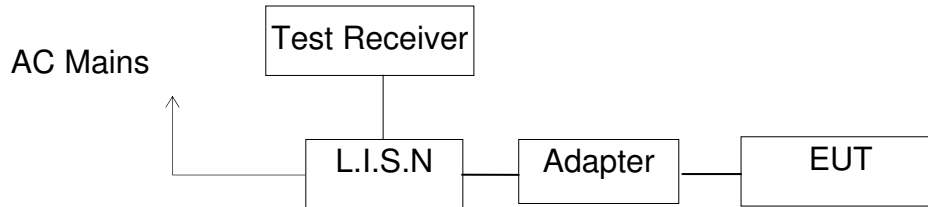

(EUT: Wireless Solar Audio Table)

### 5.2. Power Line Conducted Emission Measurement Limits

Frequency (MHz)	Limit dB( $\mu$ V)	
	Quasi-peak Level	Average Level
0.15 - 0.50	66.0 – 56.0 *	56.0 – 46.0 *
0.50 - 5.00	56.0	46.0
5.00 - 30.00	60.0	50.0

NOTE1: The lower limit shall apply at the transition frequencies.  
 NOTE2: The limit decreases linearly with the logarithm of the frequency in the range 0.15MHz to 0.50MHz.

### 5.3. Configuration of EUT on Measurement

The following equipments are installed on Power Line Conducted Emission Measurement to meet the commission requirement and operating regulations in a manner, which tends to maximize its emission characteristics in a normal application.

### 5.4. Operating Condition of EUT

- 5.4.1. Setup the EUT and simulator as shown as Section 5.1.
- 5.4.2. Turn on the power of all equipment.
- 5.4.3. Let the EUT work in test mode and measure it.

### 5.5. Test Procedure

The EUT is put on the plane 0.1 m high above the ground by insulating support and is connected to the power mains through a line impedance stabilization network (L.I.S.N.). This provides a 50ohm coupling impedance for the EUT system. Please refer the block diagram of the test setup and photographs. Both sides of AC lines are checked to find out the maximum conducted emission. In order to find the maximum emission levels, the relative positions of equipment and all of the interface cables shall be changed according to ANSI C63.10: 2013 on Conducted Emission Measurement.

The bandwidth of test receiver (R & S ESCS30) is set at 9kHz.

The frequency range from 150kHz to 30MHz is checked.

### 5.6. Power Line Conducted Emission Measurement Results

#### **PASS.**

The frequency range from 150kHz to 30MHz is checked.

Emissions attenuated more than 20 dB below the permissible value are not reported.

The spectral diagrams are attached as below.

**ACCURATE TECHNOLOGY CO., LTD**

**CONDUCTED EMISSION STANDARD FCC PART 15B**

EUT: Wireless Solar Audio Table M/N:#0181  
 Manufacturer: Jay Trends Merchandising Inc.  
 Operating Condition: BT operation  
 Test Site: 2#Shielding Room  
 Operator: star  
 Test Specification: L 120V/60Hz  
 Comment: Report No.:ATE20170354  
 Start of Test: 2017-3-28 / 14:46:28

**SCAN TABLE: "V 150K-30MHz fin"**

Short Description:		SUB STD VTERM2 1.70				
Start	Stop	Step	Detector	Meas. Time	IF Bandw.	Transducer
150.0 kHz	30.0 MHz	4.5 kHz	QuasiPeak	1.0 s	9 kHz	NSLK8126 2008
Average						

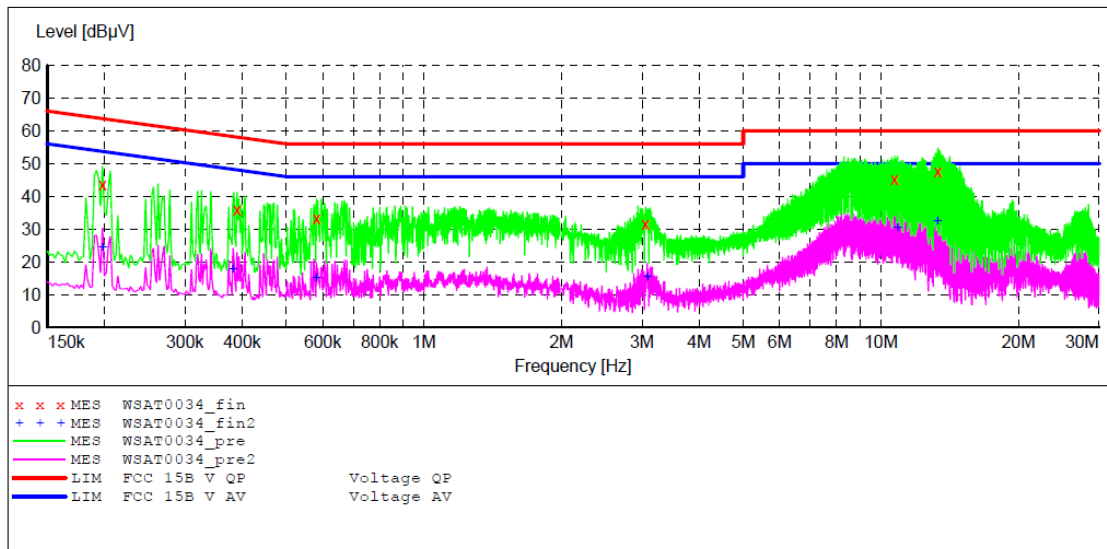

**MEASUREMENT RESULT: "WSAT0034\_fin"**

2017-3-28 14:49

Frequency MHz	Level dBµV	Transd dB	Limit dBµV	Margin dB	Detector	Line	PE
0.198000	43.50	10.8	63.7	20.2	QP	L1	GND
0.390000	35.80	11.0	58.1	22.3	QP	L1	GND
0.582000	33.30	11.0	56	22.7	QP	L1	GND
3.055000	31.50	11.3	56	24.5	QP	L1	GND
10.710000	45.40	11.6	60	14.6	QP	L1	GND
13.340000	47.70	11.6	60	12.3	QP	L1	GND

**MEASUREMENT RESULT: "WSAT0034\_fin2"**

2017-3-28 14:49

Frequency MHz	Level dBµV	Transd dB	Limit dBµV	Margin dB	Detector	Line	PE
0.198000	24.60	10.8	53.7	29.1	AV	L1	GND
0.382000	18.00	10.9	48.2	30.2	AV	L1	GND
0.582000	15.30	11.0	46	30.7	AV	L1	GND
3.080000	15.40	11.3	46	30.6	AV	L1	GND
10.870000	30.70	11.6	50	19.3	AV	L1	GND
13.315000	32.50	11.6	50	17.5	AV	L1	GND

ACCURATE TECHNOLOGY CO., LTD

CONDUCTED EMISSION STANDARD FCC PART 15B

EUT: Wireless Solar Audio Table M/N:#0181  
 Manufacturer: Jay Trends Merchandising Inc.  
 Operating Condition: BT operation  
 Test Site: 2#Shielding Room  
 Operator: star  
 Test Specification: N 120V/60Hz  
 Comment: Report No.:ATE20170354  
 Start of Test: 2017-3-28 / 14:44:05

SCAN TABLE: "V 150K-30MHz fin"

Short Description: SUB STD VTERM2 1.70  
 Start Stop Step Detector Meas. IF Transducer  
 Frequency Frequency Width Time Bandw.  
 150.0 kHz 30.0 MHz 4.5 kHz QuasiPeak 1.0 s 9 kHz NSLK8126 2008  
 Average

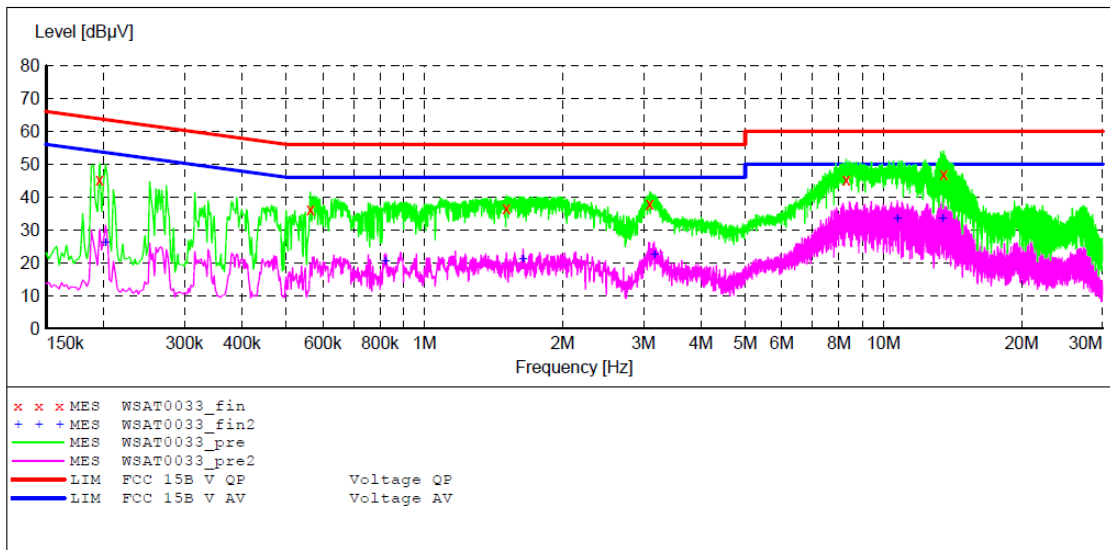

MEASUREMENT RESULT: "WSAT0033\_fin"

2017-3-28 14:45

Frequency MHz	Level dBµV	Transd dB	Limit dBµV	Margin dB	Detector	Line	PE
0.196000	45.30	10.8	63.8	18.5	QP	N	GND
0.564000	36.30	11.0	56	19.7	QP	N	GND
1.508000	36.50	11.2	56	19.5	QP	N	GND
3.095000	37.80	11.3	56	18.2	QP	N	GND
8.295000	45.30	11.5	60	14.7	QP	N	GND
13.515000	47.10	11.6	60	12.9	QP	N	GND

MEASUREMENT RESULT: "WSAT0033\_fin2"

2017-3-28 14:45

Frequency MHz	Level dBµV	Transd dB	Limit dBµV	Margin dB	Detector	Line	PE
0.202000	26.20	10.8	53.5	27.3	AV	N	GND
0.822000	20.70	11.1	46	25.3	AV	N	GND
1.640000	21.30	11.2	46	24.7	AV	N	GND
3.165000	22.70	11.4	46	23.3	AV	N	GND
10.710000	33.50	11.6	50	16.5	AV	N	GND
13.460000	33.60	11.6	50	16.4	AV	N	GND

**ACCURATE TECHNOLOGY CO., LTD**

**CONDUCTED EMISSION STANDARD FCC PART 15B**

EUT: Wireless Solar Audio Table M/N:#0181  
 Manufacturer: Jay Trends Merchandising Inc.  
 Operating Condition: BT operation  
 Test Site: 2#Shielding Room  
 Operator: star  
 Test Specification: N 240V/60Hz  
 Comment: Report No.:ATE20170354  
 Start of Test: 2017-3-28 / 14:41:21

**SCAN TABLE: "V 150K-30MHz fin"**

Short Description: SUB STD VTERM2 1.70  
 Start Stop Step Detector Meas. IF Transducer  
 Frequency Frequency Width Time Bandw.  
 150.0 kHz 30.0 MHz 4.5 kHz QuasiPeak 1.0 s 9 kHz NSLK8126 2008  
 Average

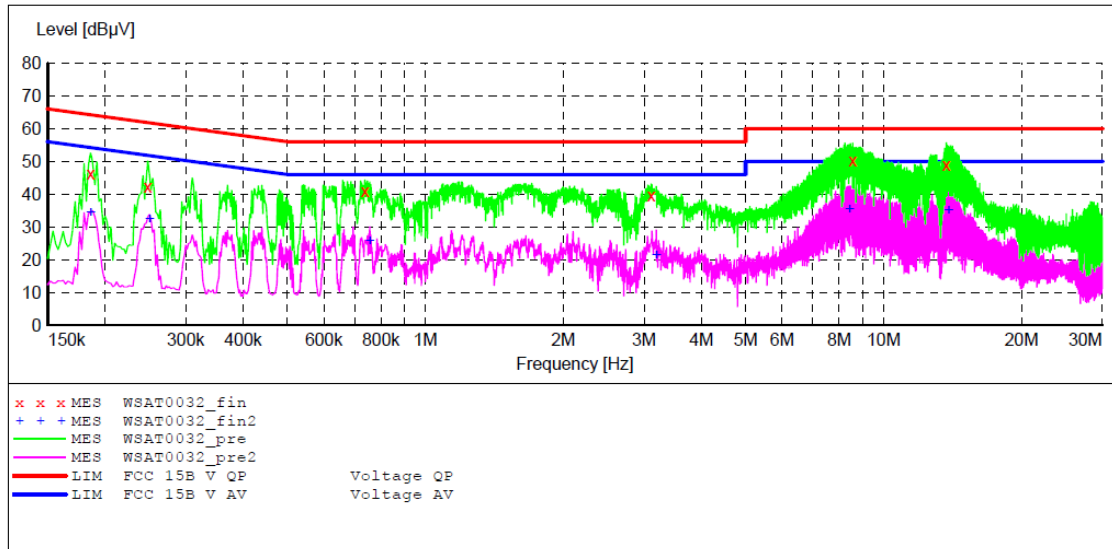

**MEASUREMENT RESULT: "WSAT0032\_fin"**

2017-3-28 14:43

Frequency MHz	Level dBµV	Transd dB	Limit dBµV	Margin dB	Detector	Line	PE
0.186000	46.10	10.8	64.2	18.1	QP	N	GND
0.248000	42.30	10.9	61.8	19.5	QP	N	GND
0.738000	40.80	11.1	56	15.2	QP	N	GND
3.110000	39.70	11.3	56	16.3	QP	N	GND
8.560000	50.20	11.5	60	9.8	QP	N	GND
13.700000	48.80	11.6	60	11.2	QP	N	GND

**MEASUREMENT RESULT: "WSAT0032\_fin2"**

2017-3-28 14:43

Frequency MHz	Level dBµV	Transd dB	Limit dBµV	Margin dB	Detector	Line	PE
0.186000	34.70	10.8	54.2	19.5	AV	N	GND
0.250000	32.70	10.9	51.8	19.1	AV	N	GND
0.756000	26.00	11.1	46	20.0	AV	N	GND
3.190000	21.70	11.4	46	24.3	AV	N	GND
8.415000	35.50	11.5	50	14.5	AV	N	GND
13.845000	35.10	11.6	50	14.9	AV	N	GND

**ACCURATE TECHNOLOGY CO., LTD**

**CONDUCTED EMISSION STANDARD FCC PART 15B**

EUT: Wireless Solar Audio Table M/N: #0181  
 Manufacturer: Jay Trends Merchandising Inc.  
 Operating Condition: BT operation  
 Test Site: 2#Shielding Room  
 Operator: star  
 Test Specification: L 240V/60Hz  
 Comment: Report No.: ATE20170354  
 Start of Test: 2017-3-28 / 14:39:50

**SCAN TABLE: "V 150K-30MHz fin"**

Short Description: SUB STD VTERM2 1.70  
 Start Stop Step Detector Meas. IF Transducer  
 Frequency Frequency Width Time Bandw.  
 150.0 kHz 30.0 MHz 4.5 kHz QuasiPeak 1.0 s 9 kHz NSLK8126 2008  
 Average

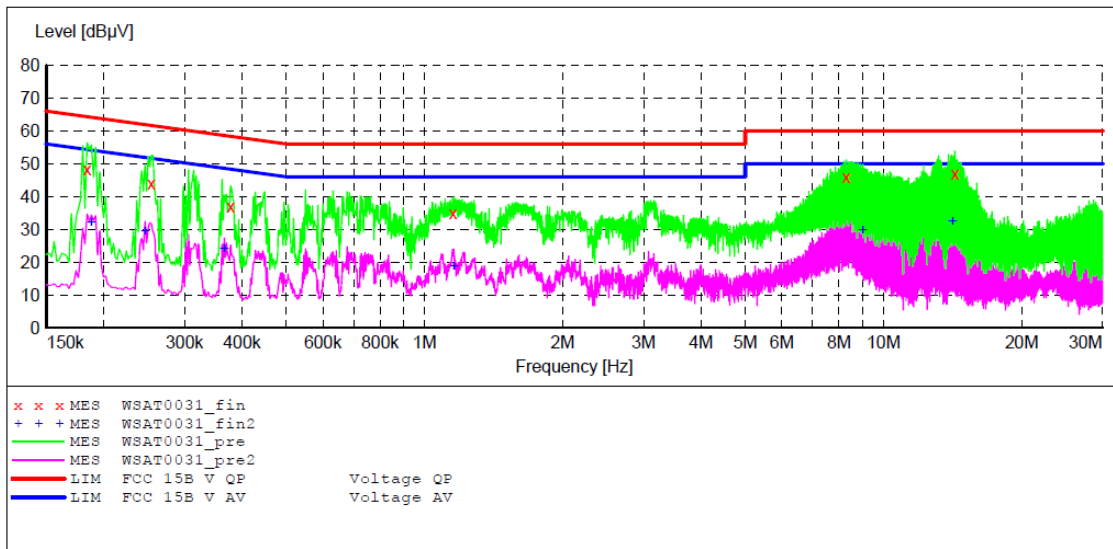

**MEASUREMENT RESULT: "WSAT0031\_fin"**

2017-3-28 14:40

Frequency MHz	Level dBµV	Transd dB	Limit dBµV	Margin dB	Detector	Line	PE
0.184000	48.20	10.8	64.3	16.1	QP	L1	GND
0.254000	43.80	10.9	61.6	17.8	QP	L1	GND
0.378000	37.00	10.9	58.3	21.3	QP	L1	GND
1.154000	35.00	11.2	56	21.0	QP	L1	GND
8.295000	46.00	11.5	60	14.0	QP	L1	GND
14.300000	46.80	11.6	60	13.2	QP	L1	GND

**MEASUREMENT RESULT: "WSAT0031\_fin2"**

2017-3-28 14:40

Frequency MHz	Level dBµV	Transd dB	Limit dBµV	Margin dB	Detector	Line	PE
0.188000	32.20	10.8	54.1	21.9	AV	L1	GND
0.246000	29.70	10.9	51.9	22.2	AV	L1	GND
0.366000	24.10	10.9	48.6	24.5	AV	L1	GND
1.158000	18.80	11.2	46	27.2	AV	L1	GND
9.015000	30.00	11.5	50	20.0	AV	L1	GND
14.135000	32.60	11.6	50	17.4	AV	L1	GND

## 6. RADIATED SPURIOUS EMISSION TEST

### 6.1. Block Diagram of Test Setup

#### 6.1.1. Block diagram of connection between the EUT and peripherals

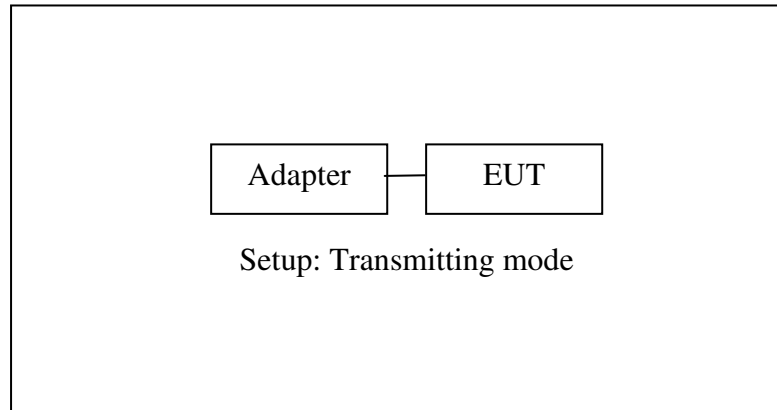

(EUT: Wireless Solar Audio Table)

#### 6.1.2. Semi-Anechoic Chamber Test Setup Diagram

(A) Radiated Emission Test Set-Up, Frequency below 30MHz

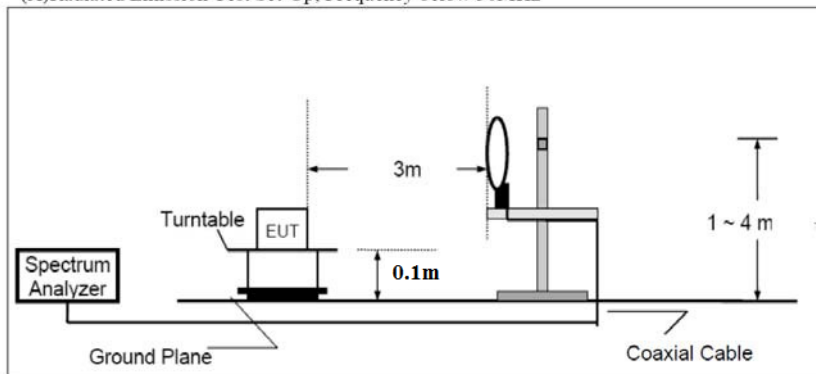

(B) Radiated Emission Test Set-Up, Frequency 30-1000MHz

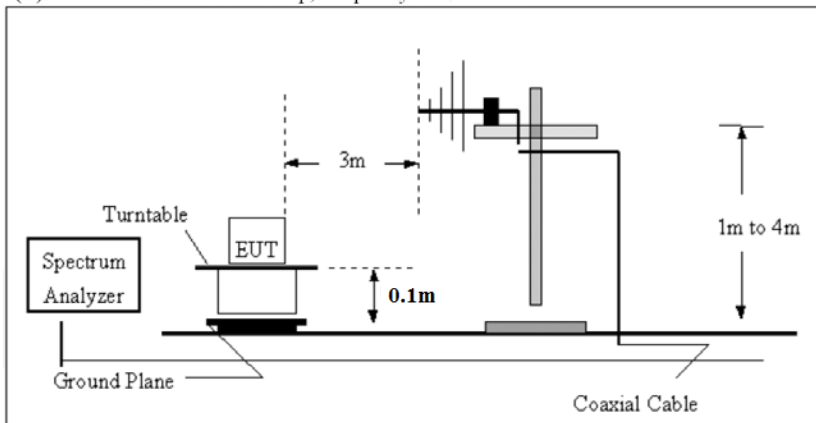

(C) Radiated Emission Test Set-Up, Frequency above 1GHz

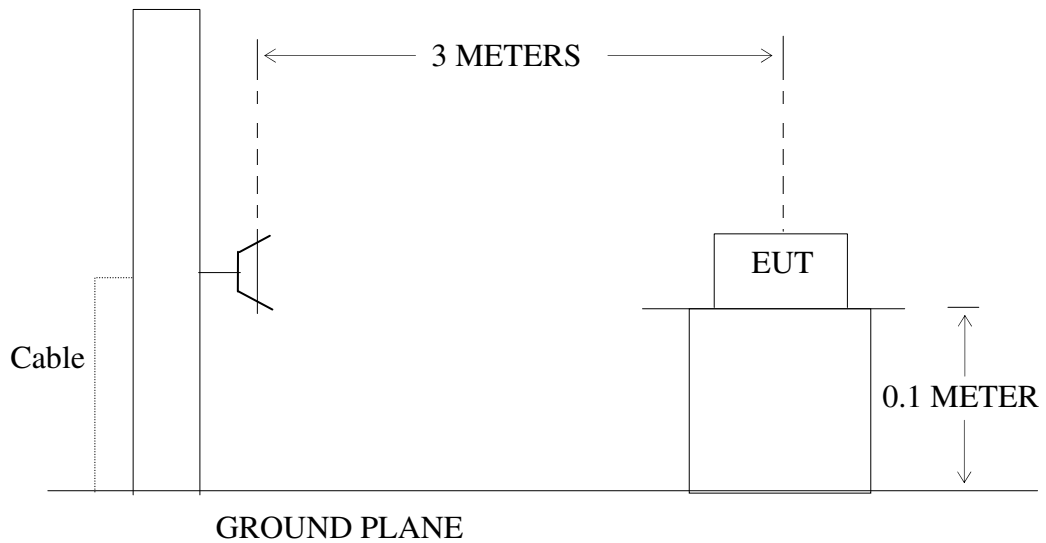

6.2. The Limit For Section 15.247(d)

Section 15.247(d): In any 100 kHz bandwidth outside the frequency band in which the spread spectrum or digitally modulated intentional radiator is operating, the radio frequency power that is produced by the intentional radiator shall be at least 20 dB below that in the 100 kHz bandwidth within the band that contains the highest level of the desired power, based on either an RF conducted or a radiated measurement, provided the transmitter demonstrates compliance with the peak conducted power limits. If the transmitter complies with the conducted power limits based on the use of RMS averaging over a time interval, as permitted under paragraph (b)(3) of this section, the attenuation required under this paragraph shall be 30 dB instead of 20 dB. Attenuation below the general limits specified in Section 15.209(a) is not required. In addition, radiated emissions which fall in the restricted bands, as defined in Section 15.205(a), must also comply with the radiated emission limits specified in Section 15.209(a).

### 6.3.Restricted bands of operation

#### 6.3.1.FCC Part 15.205 Restricted bands of operation

(a) Except as shown in paragraph (d) of this section, Only spurious emissions are permitted in any of the frequency bands listed below:

MHz	MHz	MHz	GHz
0.090-0.110	16.42-16.423	399.9-410	4.5-5.15
<sup>1</sup> 0.495-0.505	16.69475-16.69525	608-614	5.35-5.46
2.1735-2.1905	16.80425-16.80475	960-1240	7.25-7.75
4.125-4.128	25.5-25.67	1300-1427	8.025-8.5
4.17725-4.17775	37.5-38.25	1435-1626.5	9.0-9.2
4.20725-4.20775	73-74.6	1645.5-1646.5	9.3-9.5
6.215-6.218	74.8-75.2	1660-1710	10.6-12.7
6.26775-6.26825	108-121.94	1718.8-1722.2	13.25-13.4
6.31175-6.31225	123-138	2200-2300	14.47-14.5
8.291-8.294	149.9-150.05	2310-2390	15.35-16.2
8.362-8.366	156.52475-156.52525	2483.5-2500	17.7-21.4
8.37625-8.38675	156.7-156.9	2690-2900	22.01-23.12
8.41425-8.41475	162.0125-167.17	3260-3267	23.6-24.0
12.29-12.293	167.72-173.2	3332-3339	31.2-31.8
12.51975-12.52025	240-285	3345.8-3358	36.43-36.5
12.57675-12.57725	322-335.4	3600-4400	( <sup>2</sup> )
13.36-13.41			

<sup>1</sup>Until February 1, 1999, this restricted band shall be 0.490-0.510

<sup>2</sup>Above 38.6

(b) Except as provided in paragraphs (d) and (e), the field strength of emission appearing within these frequency bands shall not exceed the limits shown in Section 15.209. At frequencies equal to or less than 1000MHz, Compliance with the limits in Section 15.209 shall be demonstrated using measurement instrumentation employing a CISPR quasi-peak detector. Above 1000MHz, compliance with the emission limits in Section 15.209 shall be demonstrated based on the average value of the measured emissions. The provisions in Section 15.35 apply to these measurements.

### 6.4.Configuration of EUT on Measurement

The equipment are installed on Radiated Emission Measurement to meet the commission requirements and operating regulations in a manner which tends to maximize its emission characteristics in normal application.

## 6.5. Operating Condition of EUT

6.5.1. Setup the EUT and simulator as shown as Section 6.1.

6.5.2. Turn on the power of all equipment.

6.5.3. Let the EUT work in TX modes measure it. The transmit frequency are 2402-2480MHz. We select 2402MHz, 2440MHz, and 2480MHz TX frequency to transmit.

## 6.6. Test Procedure

The EUT and its simulators are placed on a turntable, which is 0.1 meter high above ground (Below 1GHz). The EUT and its simulators are placed on a turntable, which is 0.1 meter high above ground (Above 1GHz). The turntable can rotate 360 degrees to determine the position of the maximum emission level. EUT is set 3.0 meters away from the receiving antenna, which is mounted on an antenna tower. The antenna can be moved up and down between 1.0 meter and 4 meters to find out the maximum emission level. Broadband antenna (calibrated bi-log antenna) is used as receiving antenna. Both horizontal and vertical polarizations of the antenna are set on measurement. In order to find the maximum emission levels, all of the EUT location must be manipulated according to ANSI C63.10:2013 on radiated emission measurement. The EUT was tested in 3 orthogonal planes.

The bandwidth of test receiver is set at 9 kHz in below 30MHz. and set at 120 kHz in 30-1000MHz, and 1MHz in above 1000MHz.

The frequency range from 9 kHz to 25GHz is checked.

The final measurement in band 9-90 kHz, 110-490 kHz and above 1000MHz is performed with Average detector. Except those frequency bands mention above, the final measurement for frequencies below 1000MHz is performed with Quasi Peak detector.

The field strength is calculated by adding the antenna factor, and cable loss, and subtracting the amplifier gain from the measured reading. The basic equation calculation is as follows:

Result = Reading + Corrected Factor

Where Corrected Factor = Antenna Factor + Cable Loss – Amplifier Gain

## 6.7. The Field Strength of Radiation Emission Measurement Results

PASS.

**Note: 1. Emissions attenuated more than 20 dB below the permissible value are not reported.**

**2. After evaluation, the adapter change will only affect the radiation test (below 1GHz).**

Below 1GHz



**ACCURATE TECHNOLOGY CO., LTD.**

F1,Bldg,A,Changyuan New Material Port Keyuan Rd,  
Science & Industry Park,Nanshan Shenzhen,P.R.China

Site: 1# Chamber

Tel:+86-0755-26503290

Fax:+86-0755-26503396

Job No.: star2017 #333	Polarization: Horizontal
Standard: FCC Class B 3M Radiated	Power Source: AC 120V/60Hz
Test item: Radiation Test	Date: 17/03/31/
Temp.( C)/Hum.(%) 25 C / 55 %	Time: 10/38/16
EUT: Wireless Solar Audio Table	Engineer Signature: star
Mode: TX 2402MHz	Distance: 3m
Model: #0181	
Manufacturer: Jay Trends Merchandising Inc.	

Note: Report No.:ATE20170354

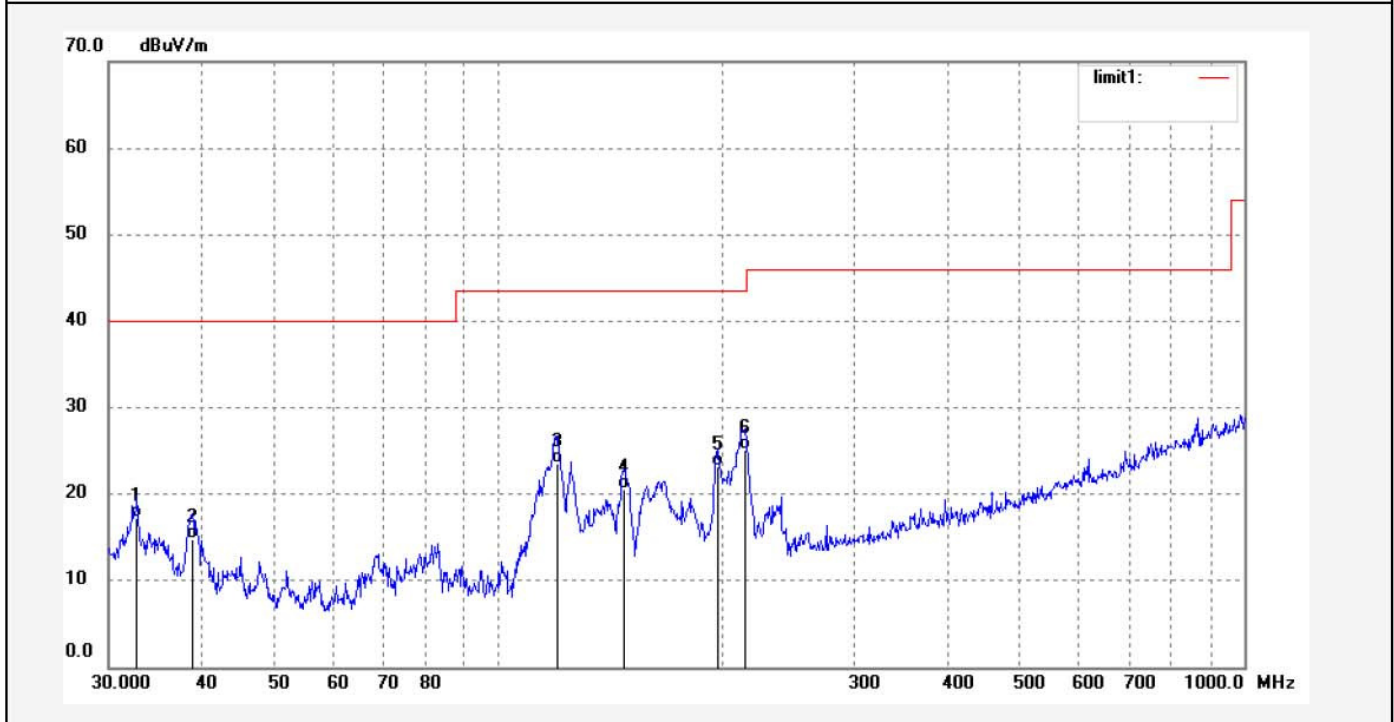

No.	Freq. (MHz)	Reading (dBuV/m)	Factor (dB)	Result (dBuV/m)	Limit (dBuV/m)	Margin (dB)	Detector	Height (cm)	Degree (deg.)	Remark
1	32.7542	32.61	-15.39	17.22	40.00	-22.78	QP			
2	38.9080	32.47	-17.62	14.85	40.00	-25.15	QP			
3	120.1888	45.39	-21.92	23.47	43.50	-20.03	QP			
4	147.3558	42.88	-22.36	20.52	43.50	-22.98	QP			
5	196.5595	42.07	-18.86	23.21	43.50	-20.29	QP			
6	213.8534	43.55	-18.43	25.12	43.50	-18.38	QP			

Job No.: star2017 #332	Polarization: Vertical
Standard: FCC Class B 3M Radiated	Power Source: AC 120V/60Hz
Test item: Radiation Test	Date: 17/03/31/
Temp.( C)/Hum.(%) 25 C / 55 %	Time: 10/31/00
EUT: Wireless Solar Audio Table	Engineer Signature: star
Mode: TX 2402MHz	Distance: 3m
Model: #0181	
Manufacturer: Jay Trends Merchandising Inc.	

Note: Report No.:ATE20170354

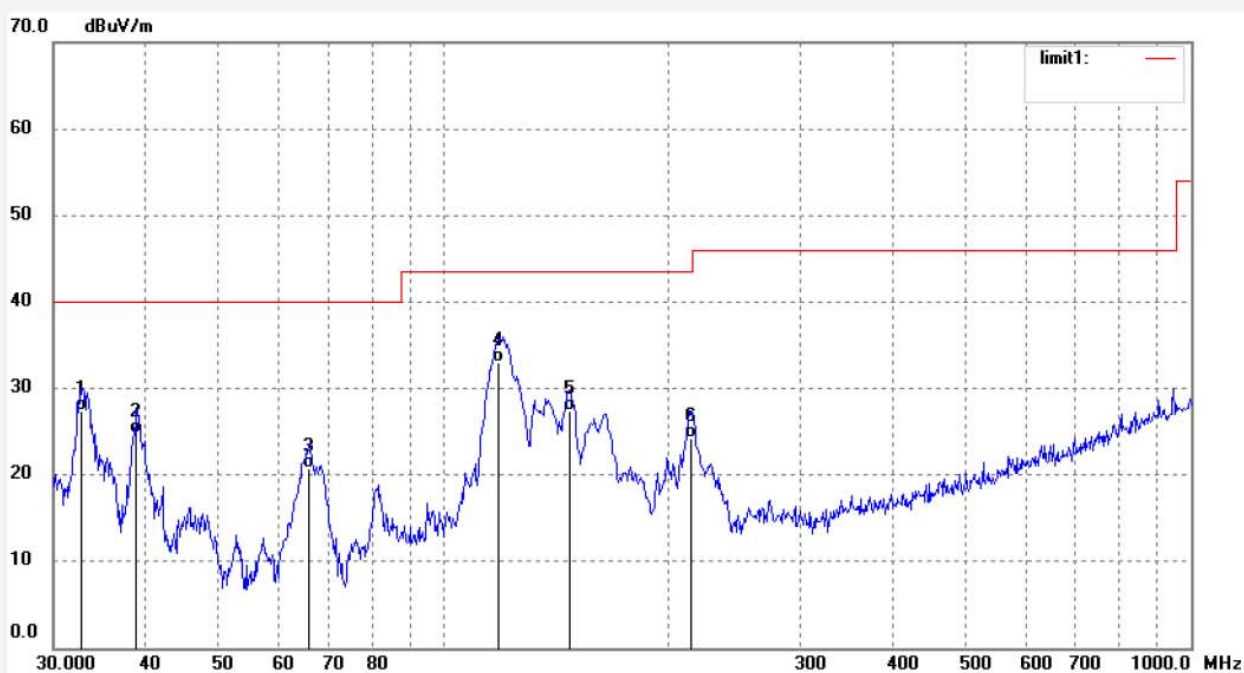

No.	Freq. (MHz)	Reading (dBuV/m)	Factor (dB)	Result (dBuV/m)	Limit (dBuV/m)	Margin (dB)	Detector	Height (cm)	Degree (deg.)	Remark
1	32.6394	42.74	-15.36	27.38	40.00	-12.62	QP			
2	38.7714	42.33	-17.57	24.76	40.00	-15.24	QP			
3	65.9067	42.67	-21.93	20.74	40.00	-19.26	QP			
4	118.5113	54.81	-21.90	32.91	43.50	-10.59	QP			
5	147.3558	49.67	-22.36	27.31	43.50	-16.19	QP			
6	213.8534	42.66	-18.43	24.23	43.50	-19.27	QP			

Job No.: star2017 #334	Polarization: Horizontal
Standard: FCC Class B 3M Radiated	Power Source: AC 120V/60Hz
Test item: Radiation Test	Date: 17/03/31/
Temp.( C)/Hum.(%) 25 C / 55 %	Time: 10/43/35
EUT: Wireless Solar Audio Table	Engineer Signature: star
Mode: TX 2440MHz	Distance: 3m
Model: #0181	
Manufacturer: Jay Trends Merchandising Inc.	

Note: Report No.:ATE20170354

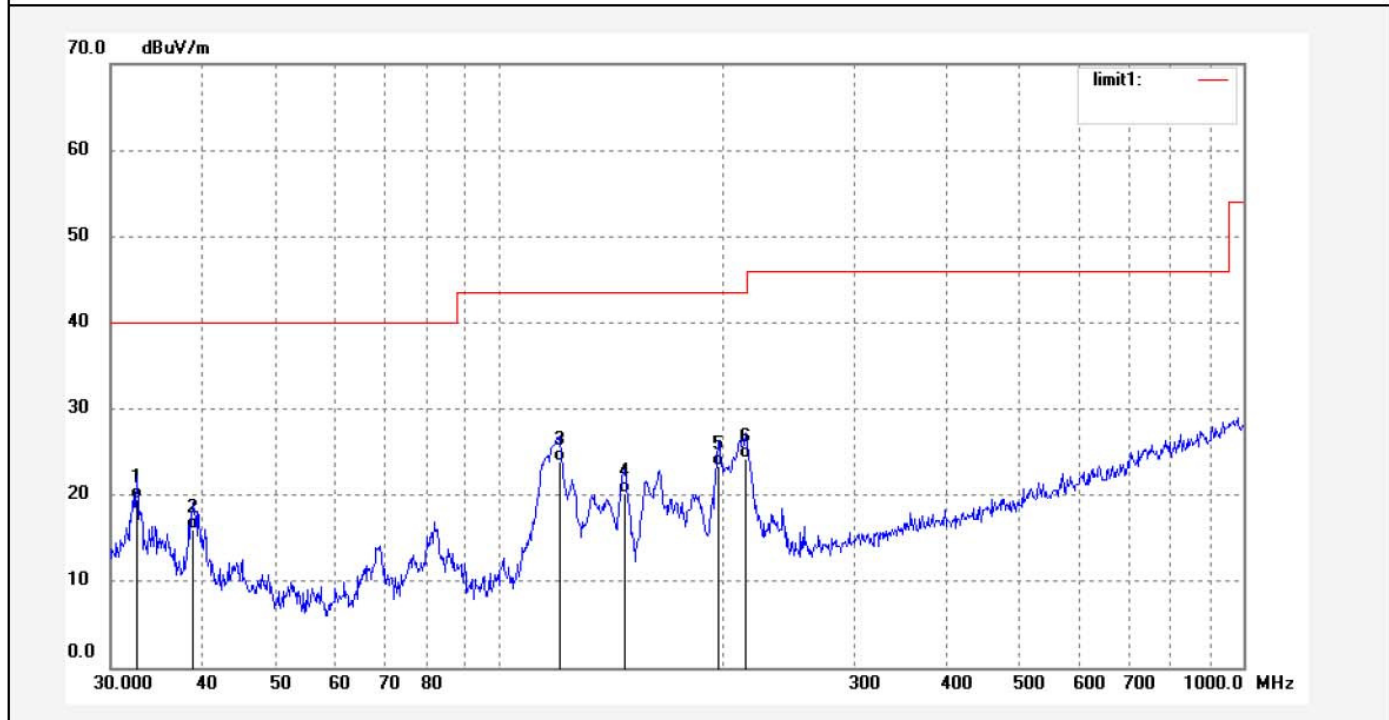

No.	Freq. (MHz)	Reading (dBuV/m)	Factor (dB)	Result (dBuV/m)	Limit (dBuV/m)	Margin (dB)	Detector	Height (cm)	Degree (deg.)	Remark
1	32.5248	34.86	-15.32	19.54	40.00	-20.46	QP			
2	38.7714	33.62	-17.57	16.05	40.00	-23.95	QP			
3	120.6118	45.84	-21.94	23.90	43.50	-19.60	QP			
4	147.3558	42.53	-22.36	20.17	43.50	-23.33	QP			
5	197.2513	42.11	-18.81	23.30	43.50	-20.20	QP			
6	213.8534	42.64	-18.43	24.21	43.50	-19.29	QP			

Job No.: star2017 #335	Polarization: Vertical
Standard: FCC Class B 3M Radiated	Power Source: AC 120V/60Hz
Test item: Radiation Test	Date: 17/03/31/
Temp.( C)/Hum.(%) 25 C / 55 %	Time: 10/51/41
EUT: Wireless Solar Audio Table	Engineer Signature: star
Mode: TX 2440MHz	Distance: 3m
Model: #0181	
Manufacturer: Jay Trends Merchandising Inc.	

Note: Report No.:ATE20170354

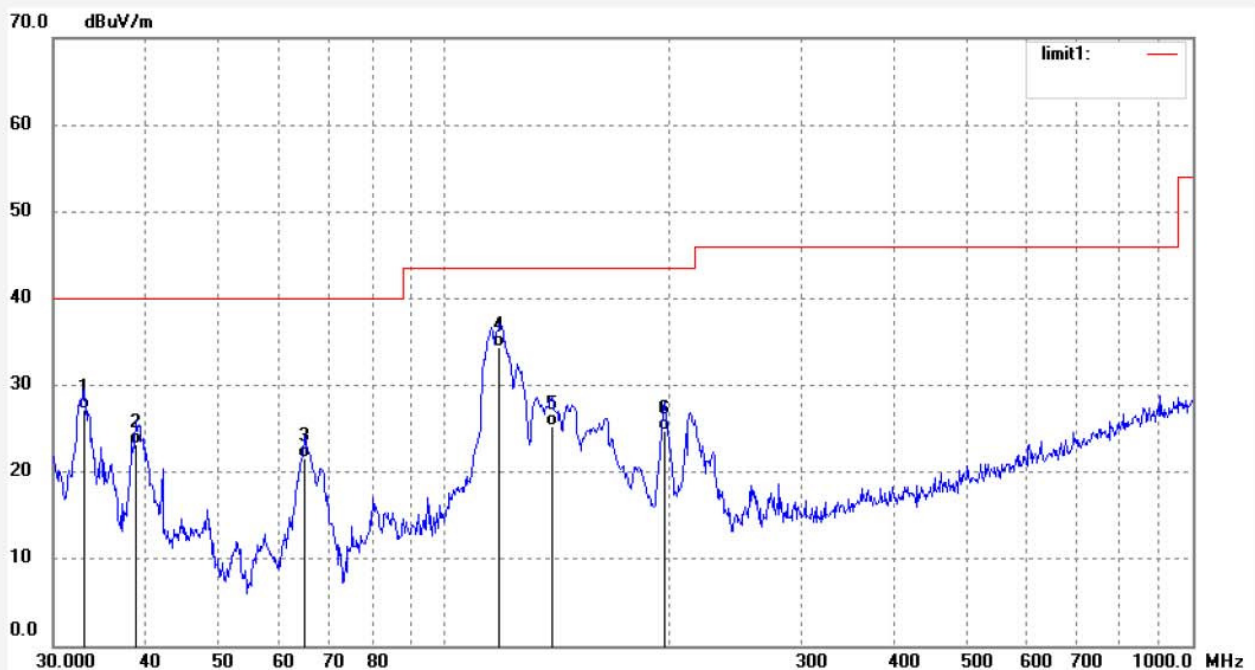

No.	Freq. (MHz)	Reading (dBuV/m)	Factor (dB)	Result (dBuV/m)	Limit (dBuV/m)	Margin (dB)	Detector	Height (cm)	Degree (deg.)	Remark
1	32.9853	42.68	-15.45	27.23	40.00	-12.77	QP			
2	38.6355	40.62	-17.51	23.11	40.00	-16.89	QP			
3	64.9869	43.58	-21.90	21.68	40.00	-18.32	QP			
4	118.5113	56.34	-21.90	34.44	43.50	-9.06	QP			
5	139.3006	47.58	-22.30	25.28	43.50	-18.22	QP			
6	196.5595	43.57	-18.86	24.71	43.50	-18.79	QP			

Job No.: star2017 #337	Polarization: Horizontal
Standard: FCC Class B 3M Radiated	Power Source: AC 120V/60Hz
Test item: Radiation Test	Date: 17/03/31/
Temp.( C)/Hum.(%) 25 C / 55 %	Time: 11/03/06
EUT: Wireless Solar Audio Table	Engineer Signature: star
Mode: TX 2480MHz	Distance: 3m
Model: #0181	
Manufacturer: Jay Trends Merchandising Inc.	

Note: Report No.:ATE20170354

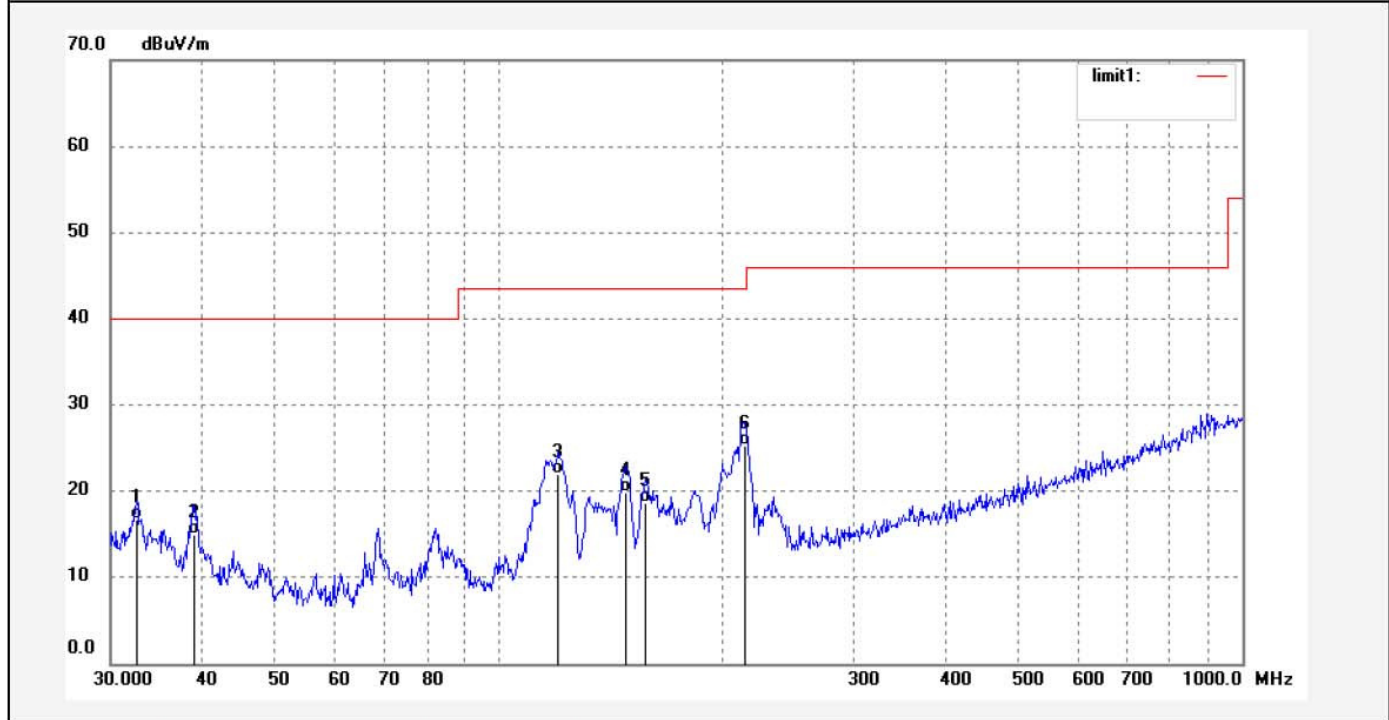

No.	Freq. (MHz)	Reading (dBuV/m)	Factor (dB)	Result (dBuV/m)	Limit (dBuV/m)	Margin (dB)	Detector	Height (cm)	Degree (deg.)	Remark
1	32.5248	32.02	-15.32	16.70	40.00	-23.30	QP			
2	38.9080	32.64	-17.62	15.02	40.00	-24.98	QP			
3	120.1888	43.87	-21.92	21.95	43.50	-21.55	QP			
4	147.8746	42.22	-22.36	19.86	43.50	-23.64	QP			
5	157.5289	40.24	-21.64	18.60	43.50	-24.90	QP			
6	213.8534	43.67	-18.43	25.24	43.50	-18.26	QP			

Job No.: star2017 #336	Polarization: Vertical
Standard: FCC Class B 3M Radiated	Power Source: AC 120V/60Hz
Test item: Radiation Test	Date: 17/03/31/
Temp.( C)/Hum.(%) 25 C / 55 %	Time: 10/57/30
EUT: Wireless Solar Audio Table	Engineer Signature: star
Mode: TX 2480MHz	Distance: 3m
Model: #0181	
Manufacturer: Jay Trends Merchandising Inc.	

Note: Report No.:ATE20170354

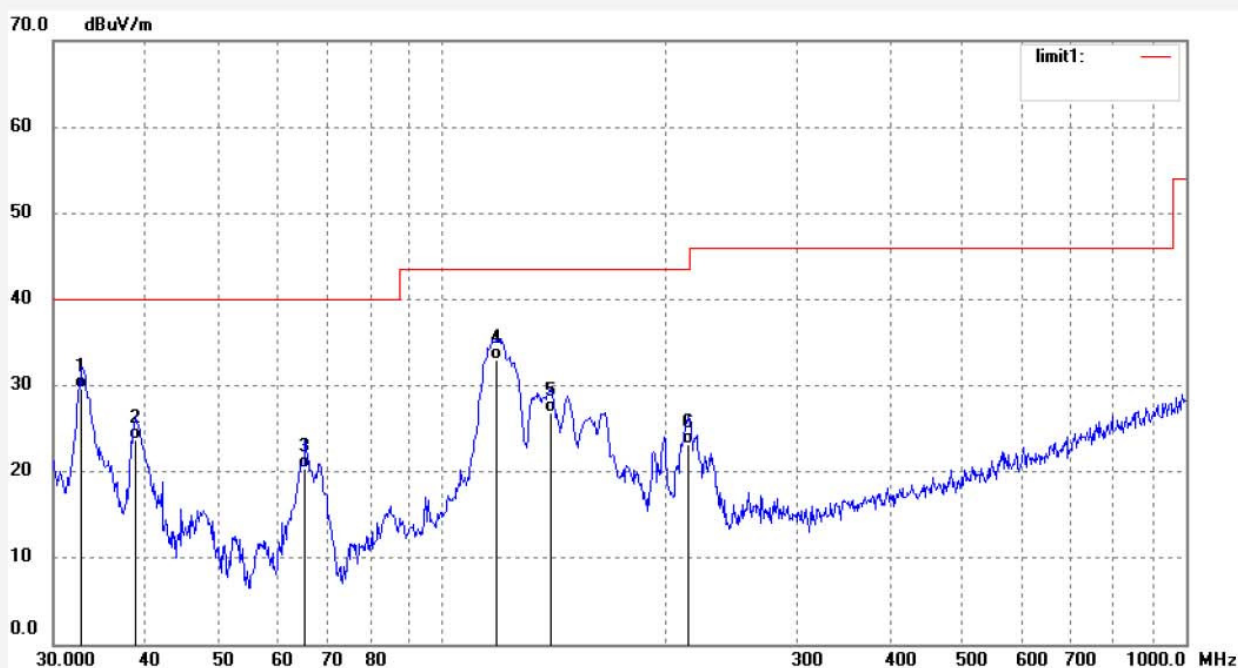

No.	Freq. (MHz)	Reading (dBuV/m)	Factor (dB)	Result (dBuV/m)	Limit (dBuV/m)	Margin (dB)	Detector	Height (cm)	Degree (deg.)	Remark
1	32.7542	45.03	-15.39	29.64	40.00	-10.36	QP			
2	38.7714	41.20	-17.57	23.63	40.00	-16.37	QP			
3	65.4451	42.39	-21.92	20.47	40.00	-19.53	QP			
4	118.5113	54.88	-21.90	32.98	43.50	-10.52	QP			
5	140.2829	49.25	-22.31	26.94	43.50	-16.56	QP			
6	214.6063	41.57	-18.42	23.15	43.50	-20.35	QP			

## 7. ANTENNA REQUIREMENT

### 7.1.The Requirement

According to Section 15.203, an intentional radiator shall be designed to ensure that no antenna other than that furnished by the responsible party shall be used with the device.

### 7.2.Antenna Construction

Device is equipped with PCB antenna, which isn't displaced by other antenna. The Antenna gain of EUT is 0dBi. Therefore, the equipment complies with the antenna requirement of Section 15.203.

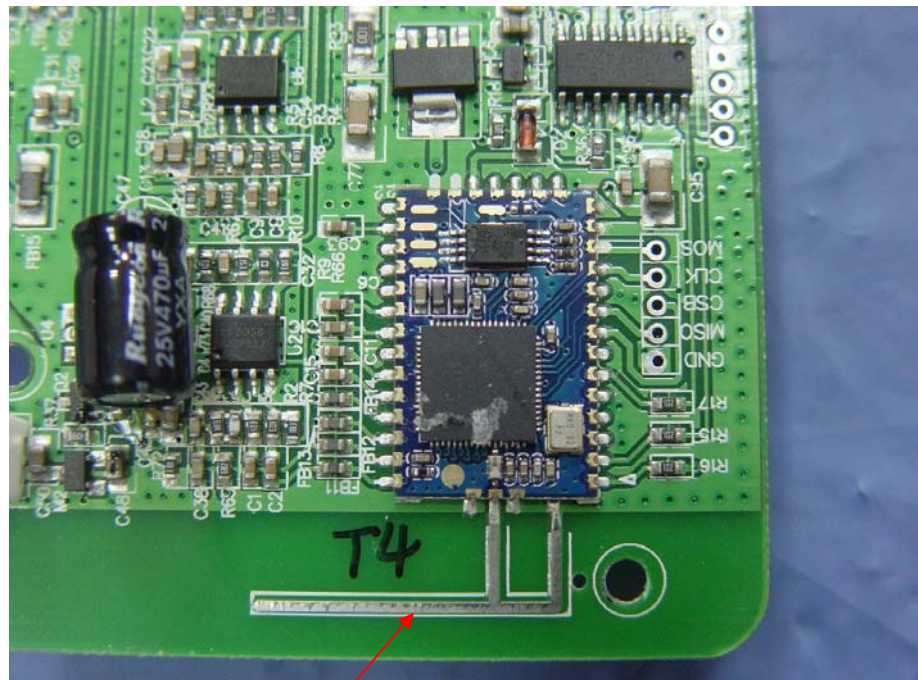

**Antenna**