

DragonBoard410c

Title		DragonBoard410c	
Size	Document Number	Rev	
D	<Doc>	A	
Date	Monday, August 31, 2015	Sheet	1 of 33

SHEET BLOCK	SCHEMATIC	SHEET BLOCK	SCHEMATIC	SHEET BLOCK	SCHEMATIC	SHEET BLOCK	SCHEMATIC
1 \	TITLE						
2 \	TABLE OF CONTENTS						
3 \	APQ8016 - CONTROL						
4 \	APQ8016 - EBIO-LPDDR3						
5 \	APQ8016 - GPIO 0-73						
6 \	APQ8016 - GPIO 74-121 / DNC						
7 \	APQ8016 - BOOT CONFIG SW						
8 \	APQ8016 - MIPI CSI/DSI						
9 \	APQ8016 - RF INTERFACE						
10 \	APQ8016 - PWR1						
11 \	APQ8016 - PWR2						
12 \	APQ8016 - PWR3						
13 \	APQ8016 - GND						
14 \	APQ8016 - DECOUPLING						
15 \	EXTERNAL BUCK REGULATORS						
16 \	PM8916 - CONTROL/CLOCKS						
17 \	PM8916 - CHARGER/GPIOS/MPPS						
18 \	PM8916 - SMPS						
19 \	PM8916 - LDOS						
20 \	PM8916 - AUDIO						
21 \	MEMORY - LPDDR3 + EMMC - CONTR						
22 \	MEMORY - LPDDR3 + EMMC - POWER						
23 \	MEMORY - USD CONNECTOR						
24 \	USB - SWITCH / HUB						
25 \	USB - CONNECTORS						
26 \	DISPLAY - DSI SWITCH						
27 \	DISPLAY - DSI TO HDMI BRIDGE						
28 \	SWITCHES/LEDS						
29 \	HS / LS EXPANSION CONNECTORS						
30 \	JTAG / UART / ANALOG EXPANSION						
31 \	WCN3620 - RF / CONTROL						
32 \	WCN3620 - PWR / GND						
33 \	WGR7640 - GPS						

APQ8016 - CONTROL

Route BBCLK1 as daisy chain. AD35 pin first and then AL34 second

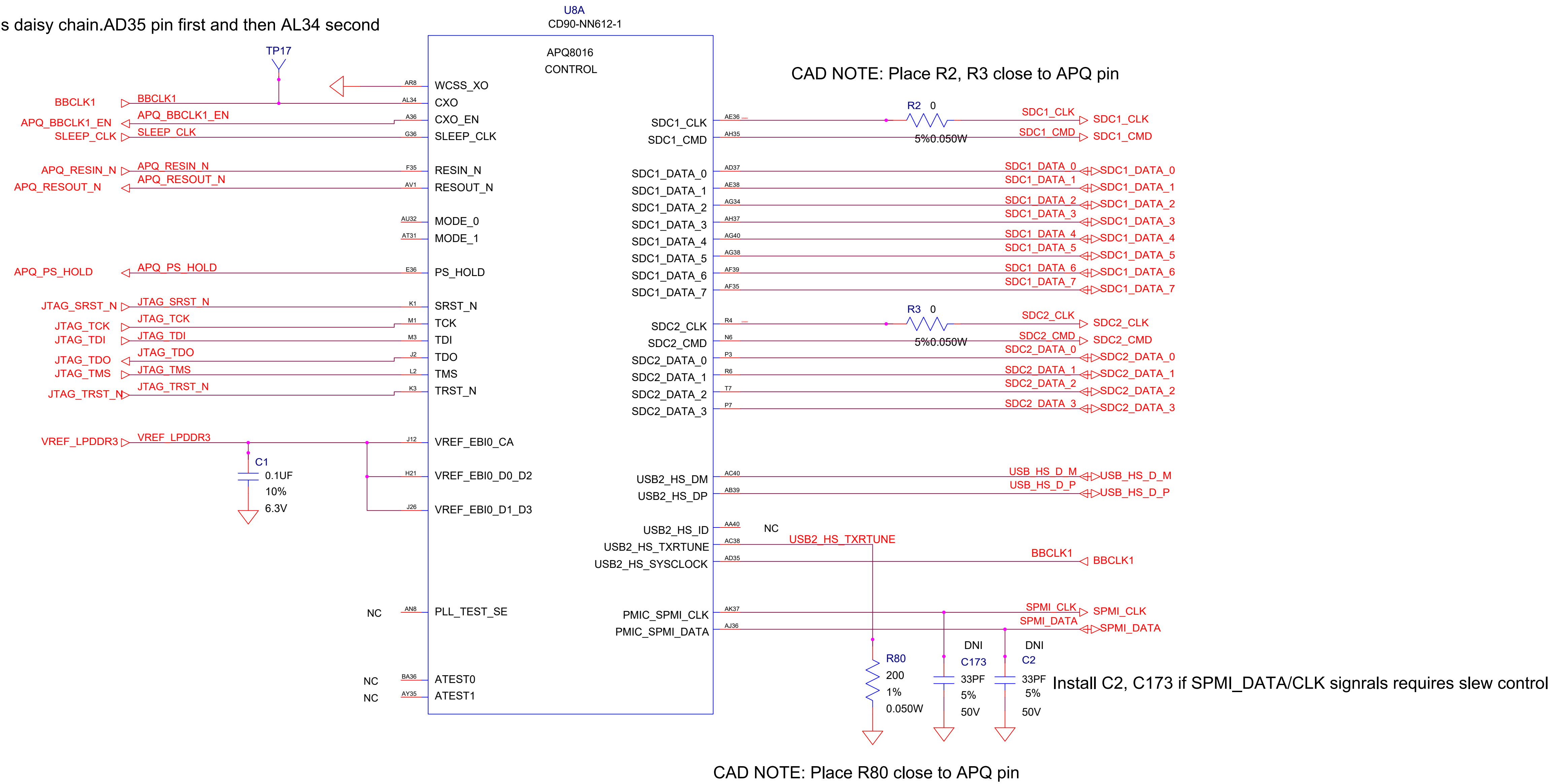

APQ8016 - EBI0-LPDDR3

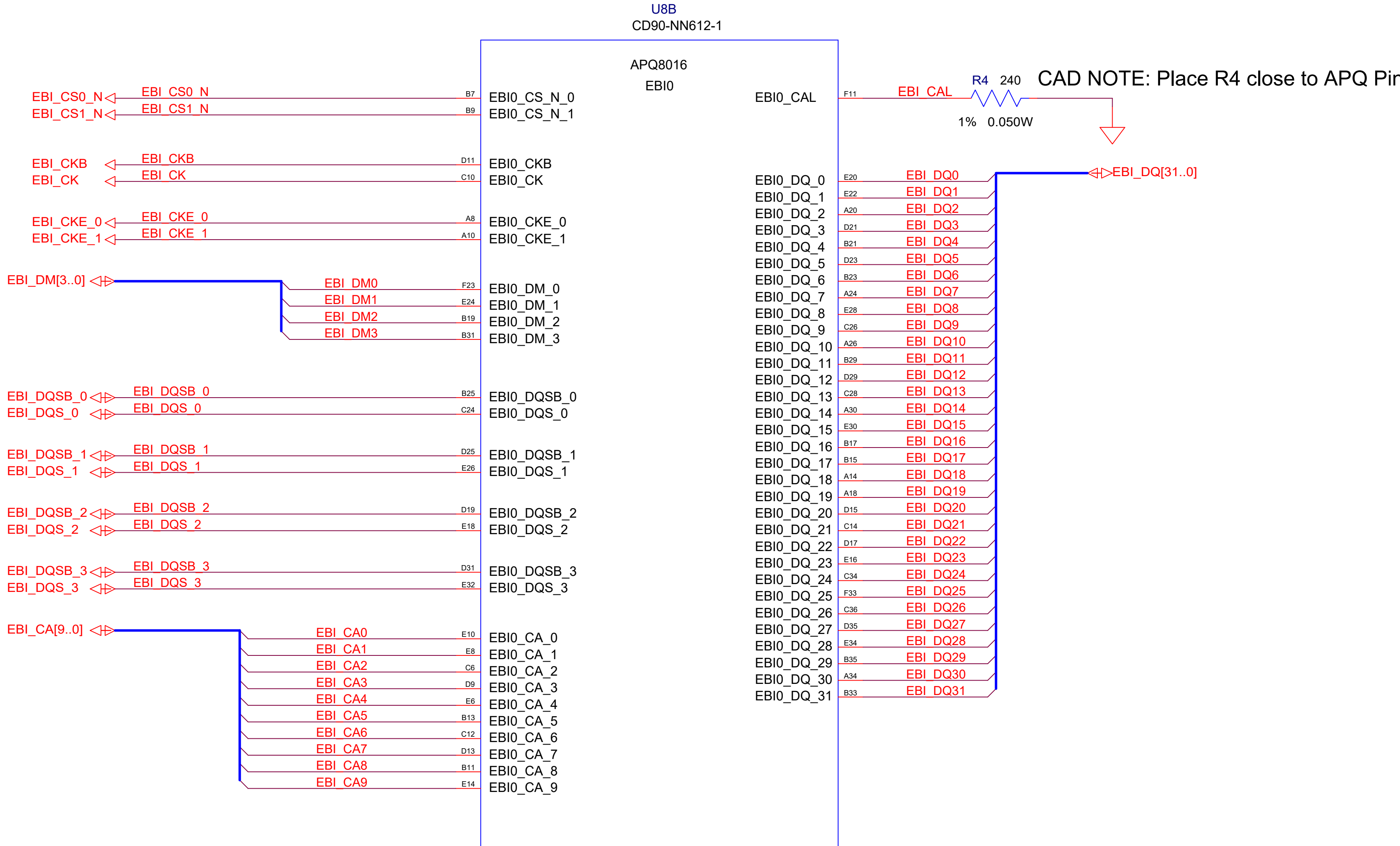

APQ8016 - GPIO 0-73

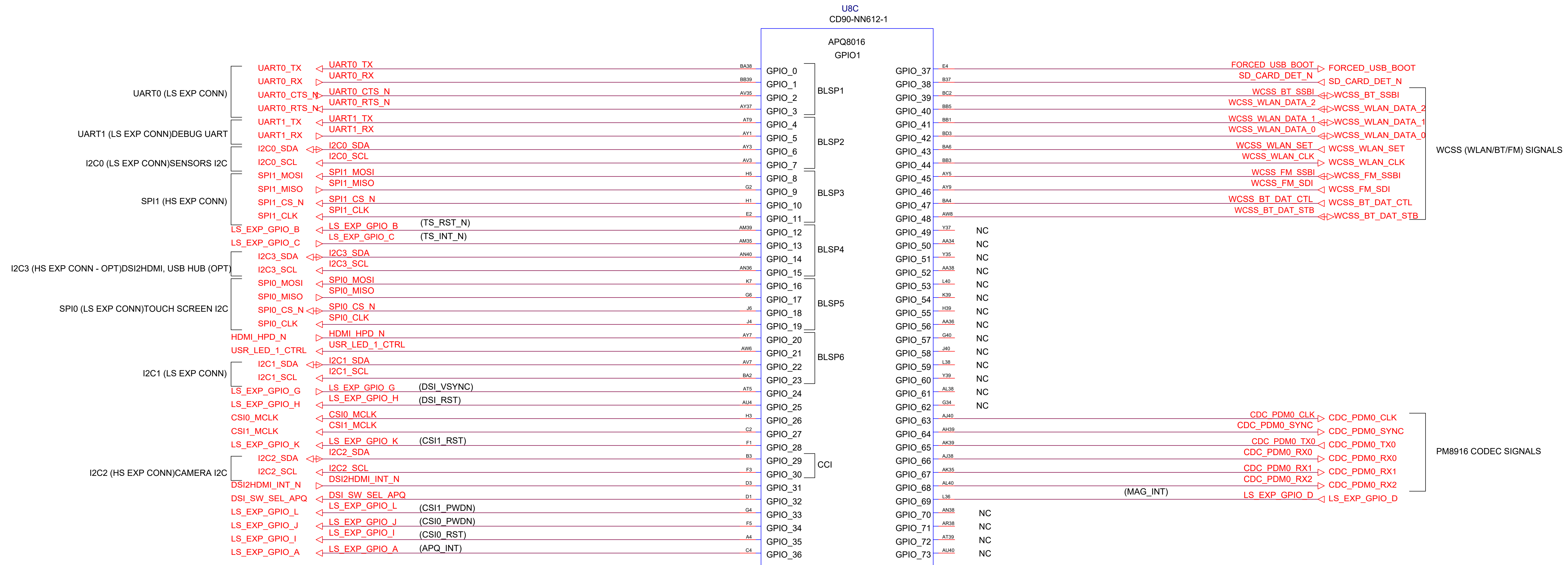

I2C PULL-UP RESISTORS

I2C0 (LS EXP CONN)SENSORS I2C

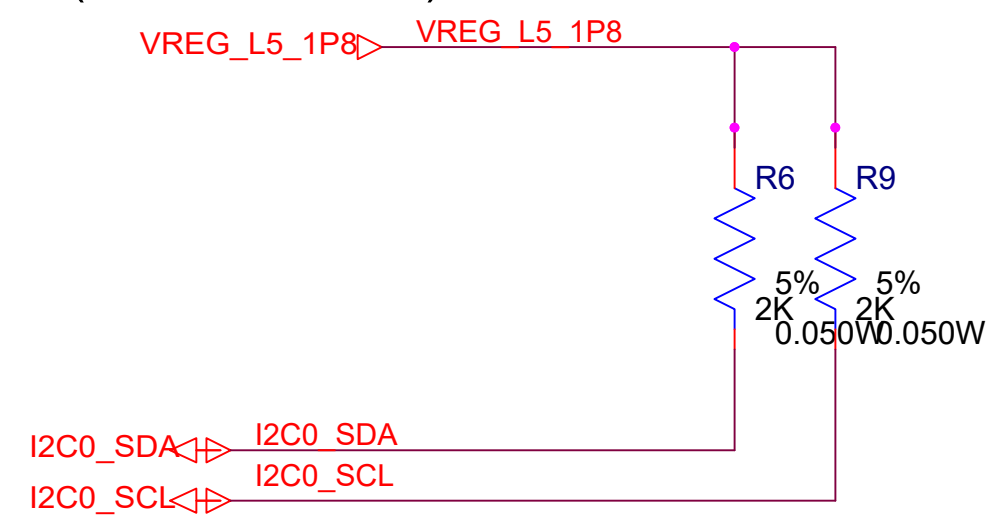

I2C2 (HS EXP CONN)CAMERA I2C

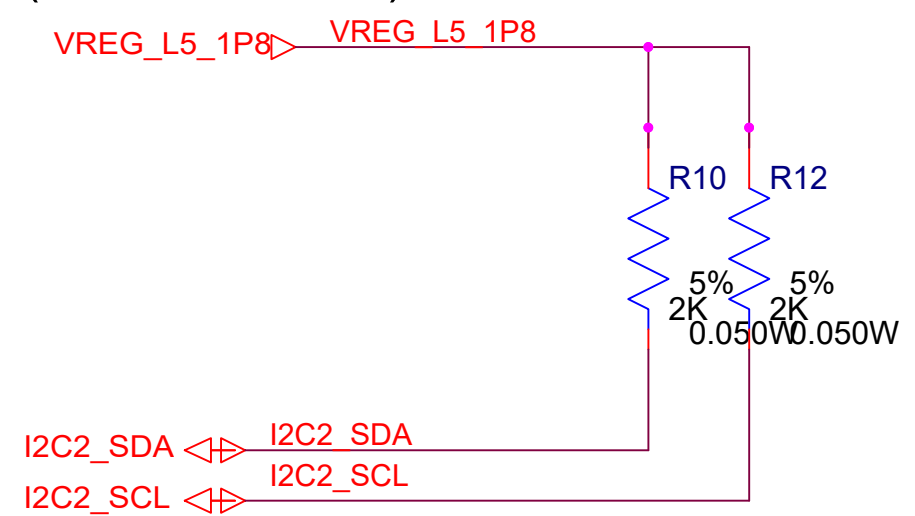

I2C1 (LS EXP CONN)

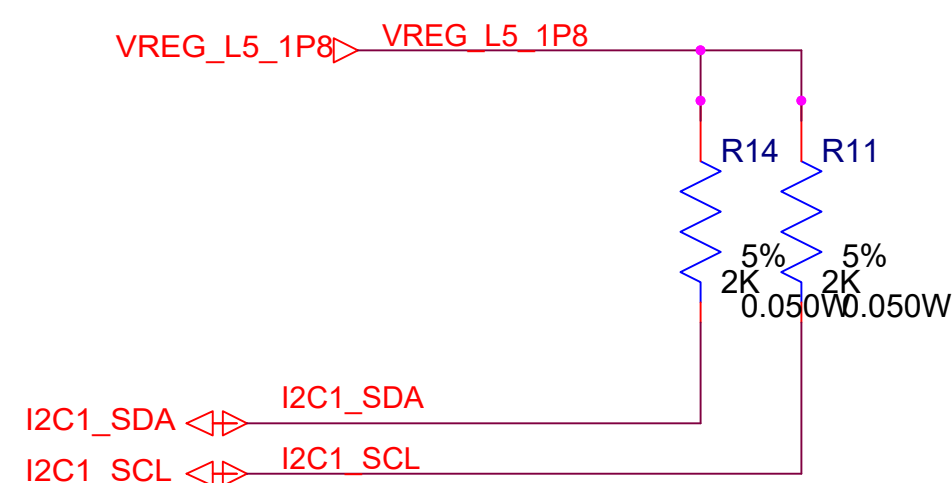

I2C3 (HS EXP CONN - OPT)DSI2HDMIUSB HUB (OPT)

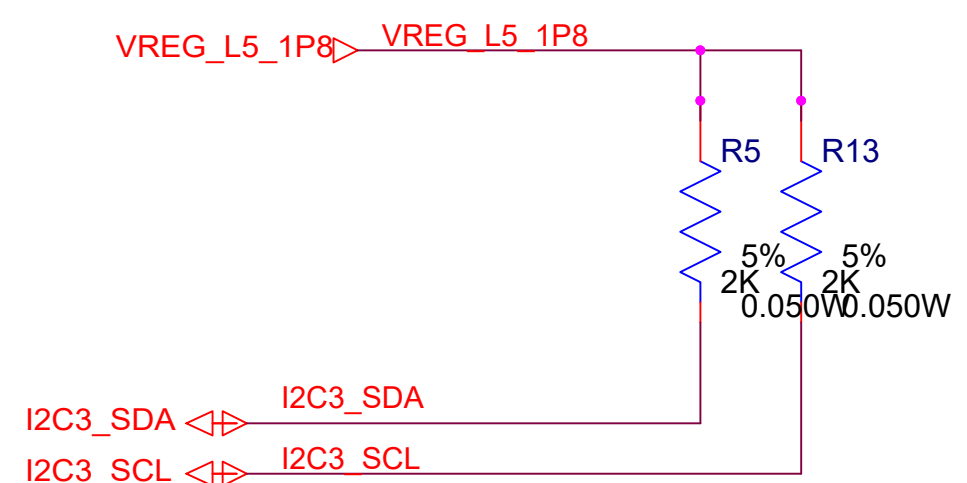

APQ8016 - GPIO 74-121 / DNC

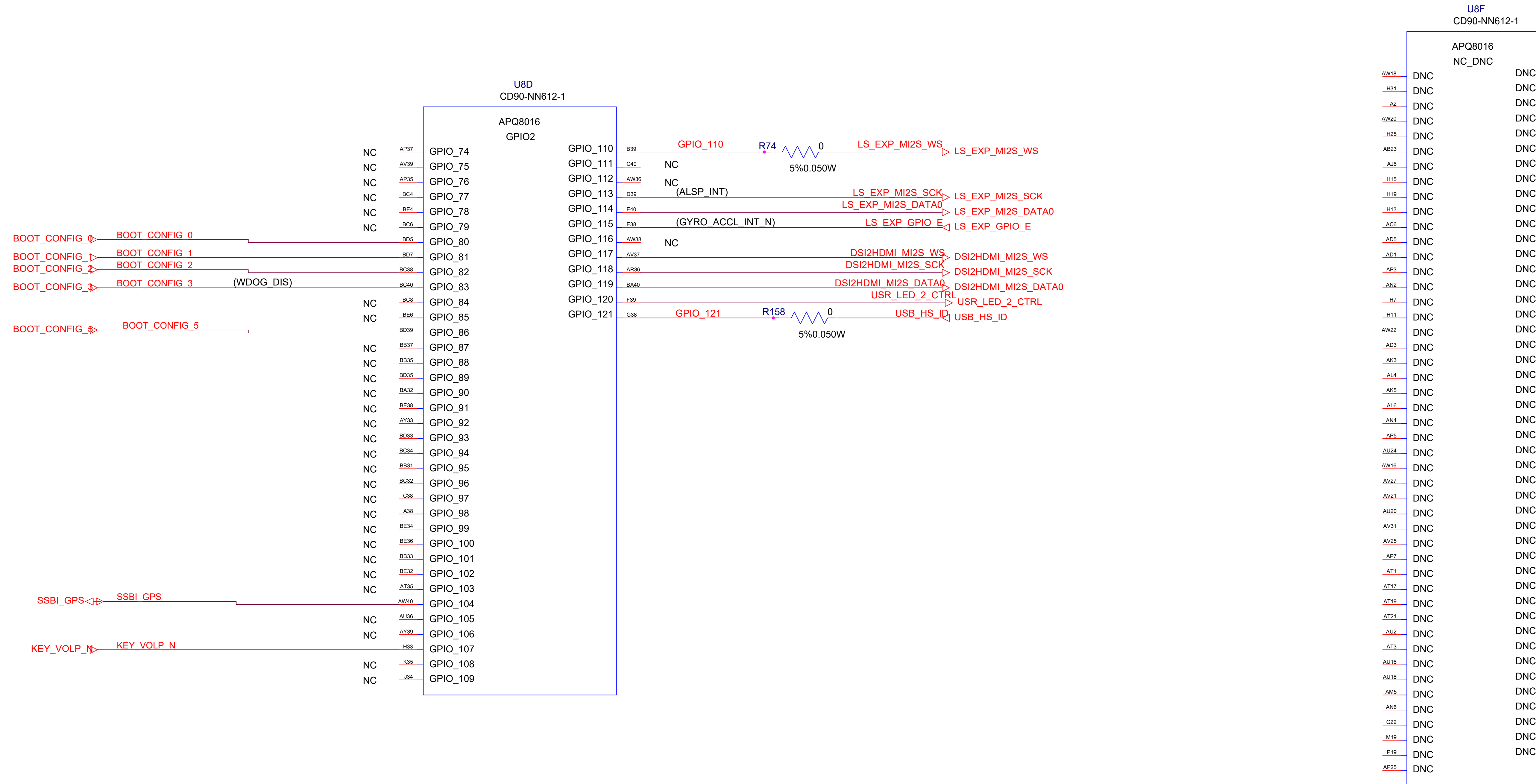

APQ8016 - BOOT CONFIG SW

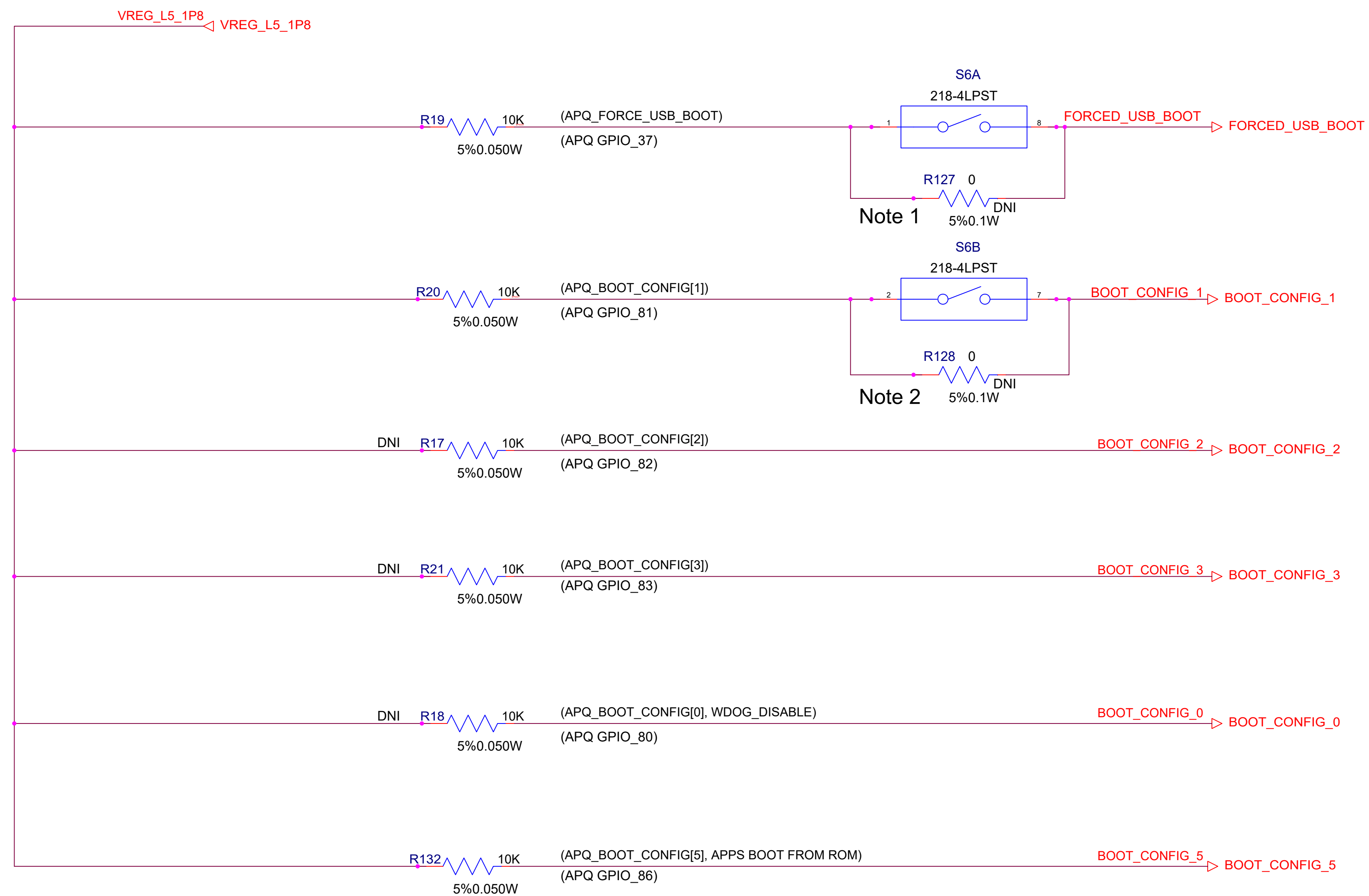

BOOT CONFIGURATIONS

BOOT_CONFIG[3:1]	BOOT OPTIONS
0b000	SDC1 --> SDC2 --> USB2.0
0b001	SDC2 --> SDC1 --> USB2.0
0b010	SDC1 --> USB2.0
0b011	USB2.0

Default Boot Config (0b000) is eMMC on the SDC1

Note 1: Short between resistors pads to force boot from USB when dip-switch is not installed
 Note 2: Short between resistors pads to boot from uSD when dip-switch is not installed

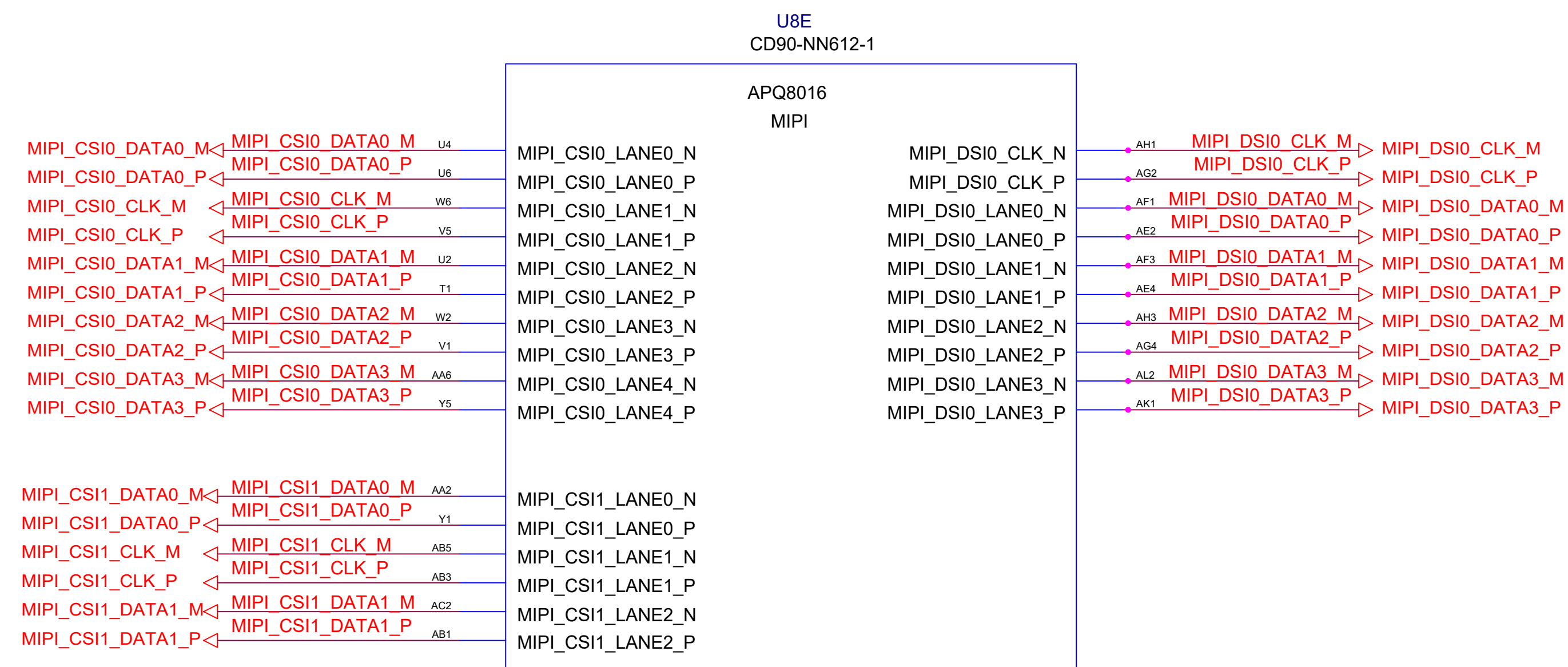

APQ8016 - RF INTERFACE

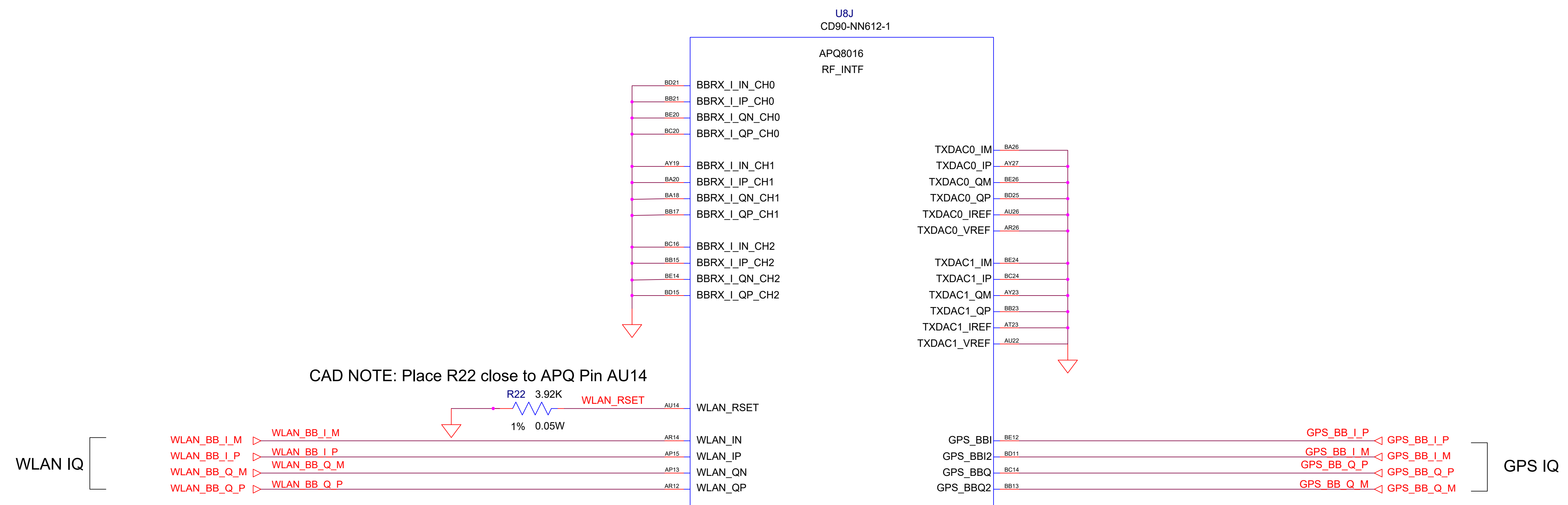

APQ8016 - PWR1

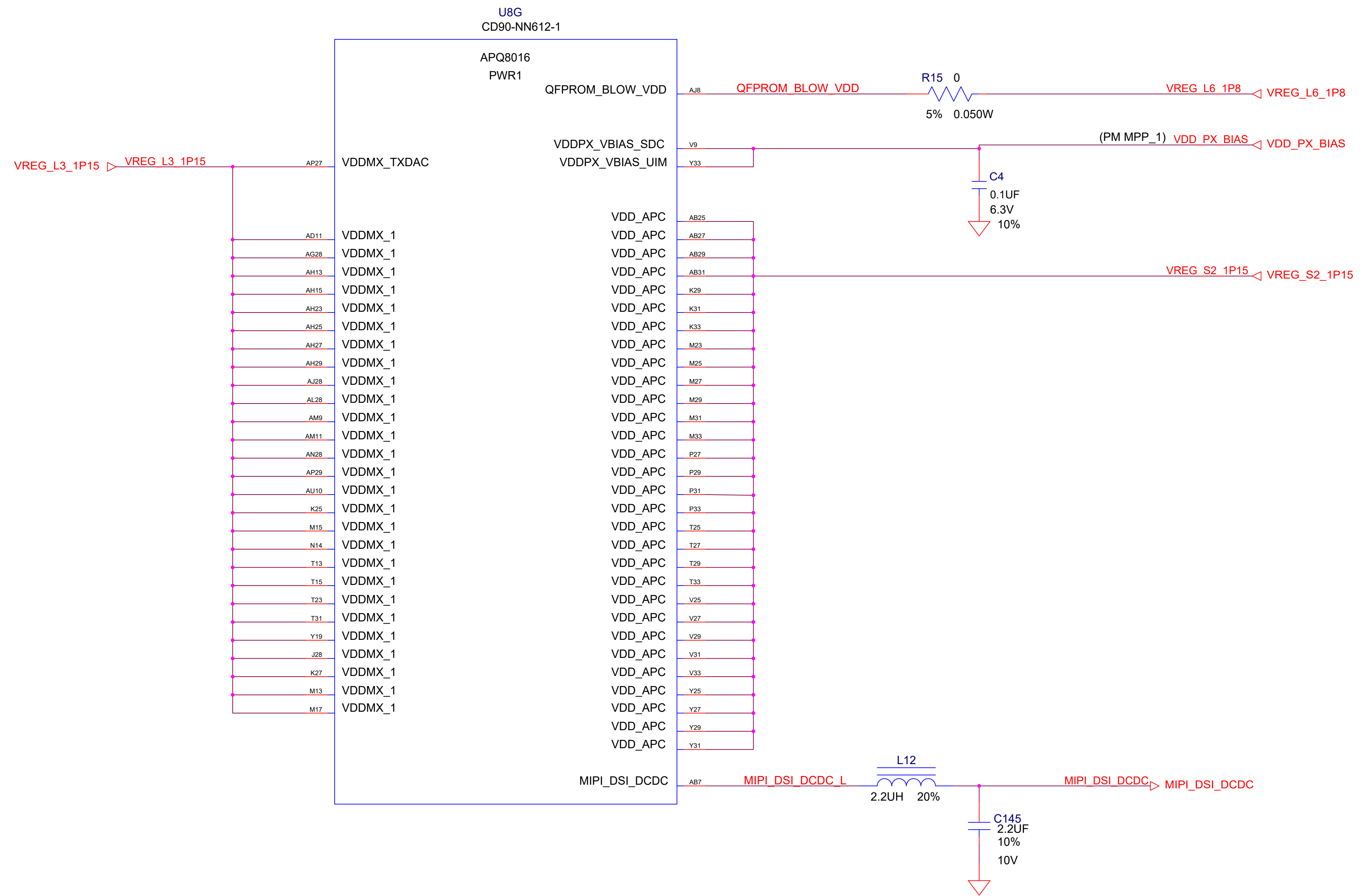

CAD NOTE: Loop to be shorted with MSM AG6 Pin

APQ8016 - PWR2

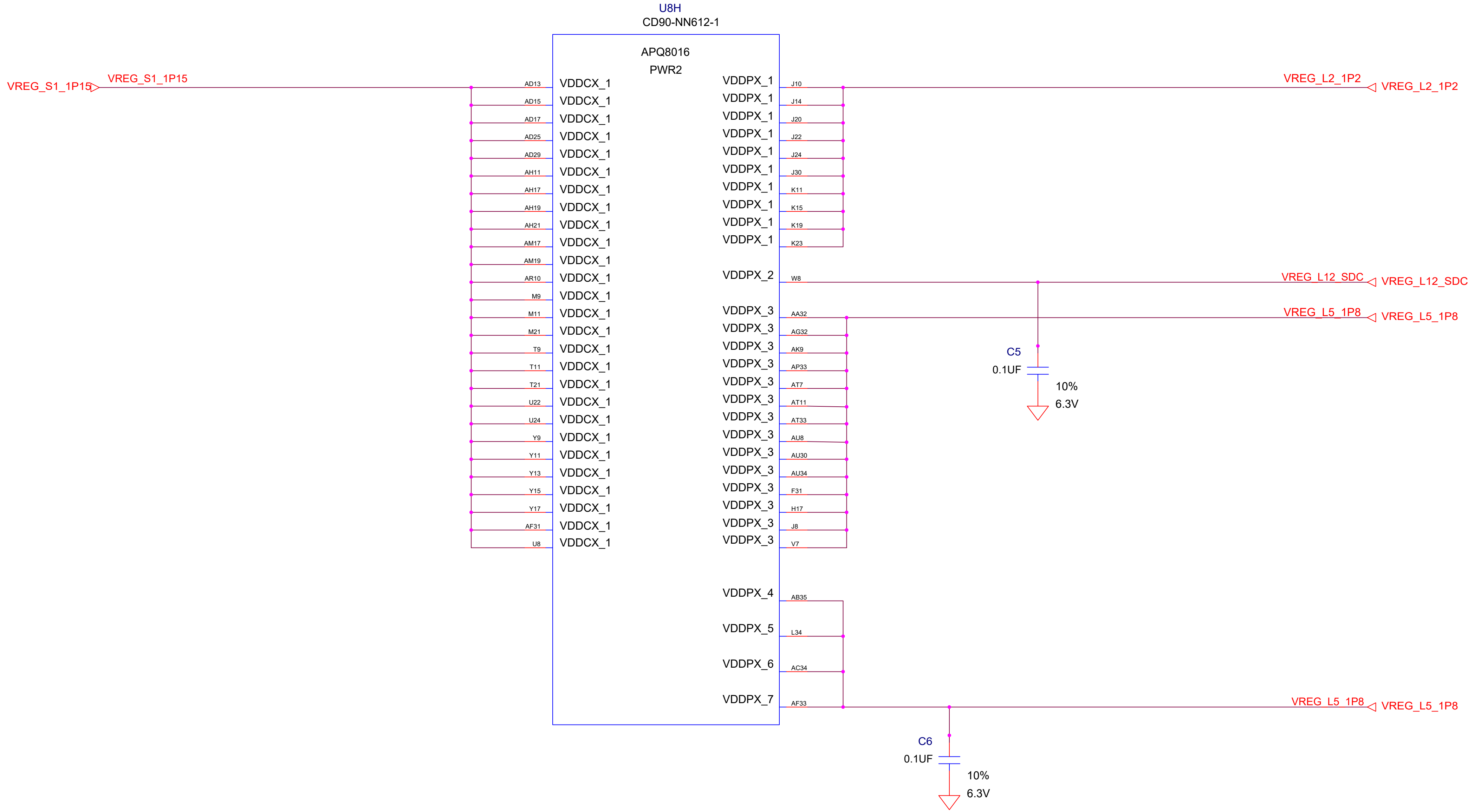

APQ8016 - PWR3

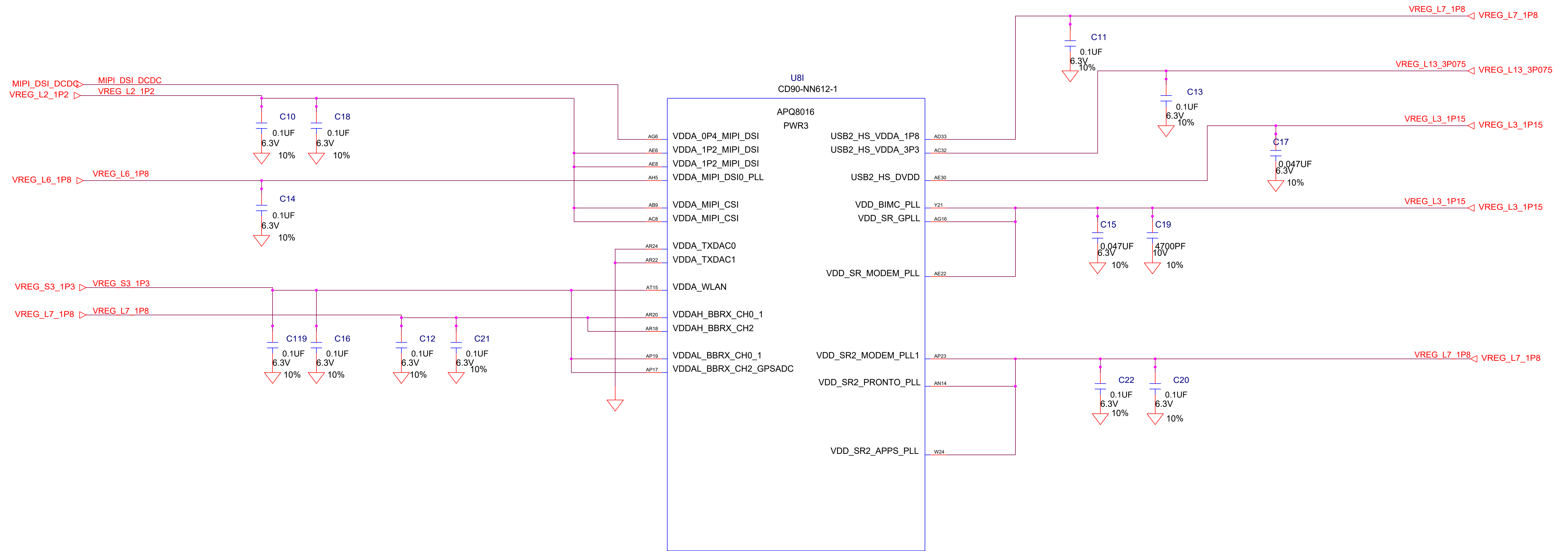

APQ8016 - GND

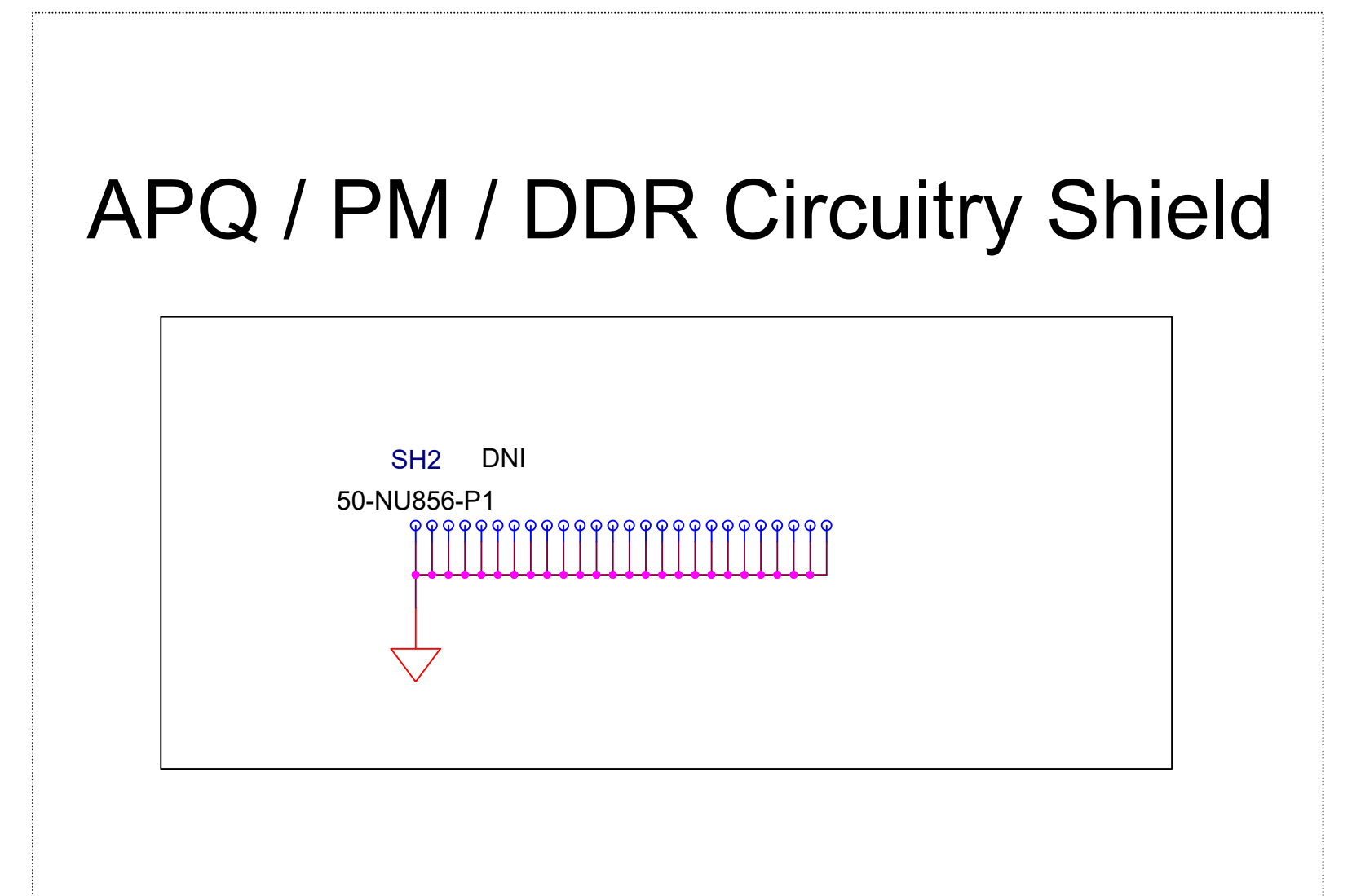
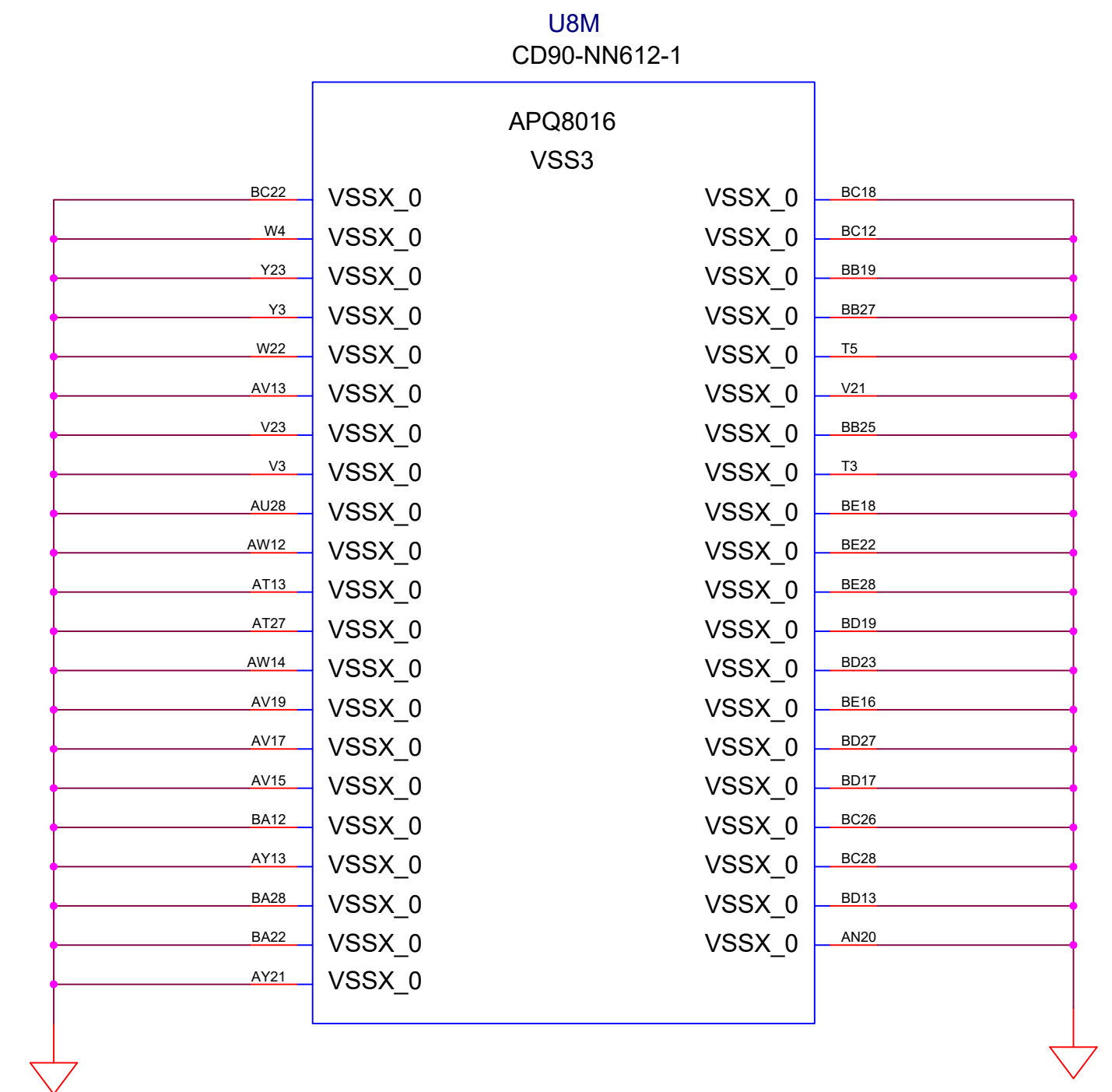
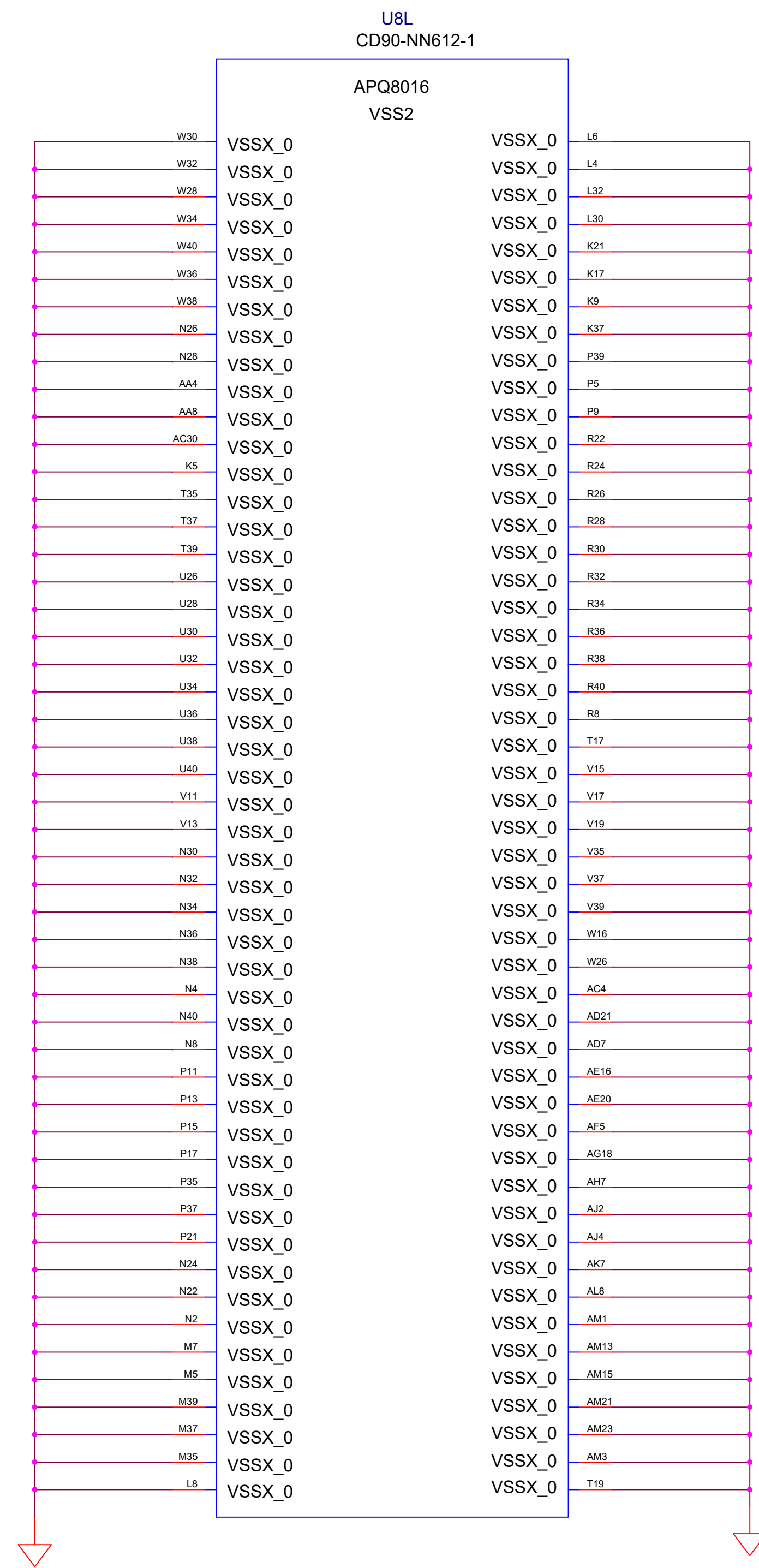
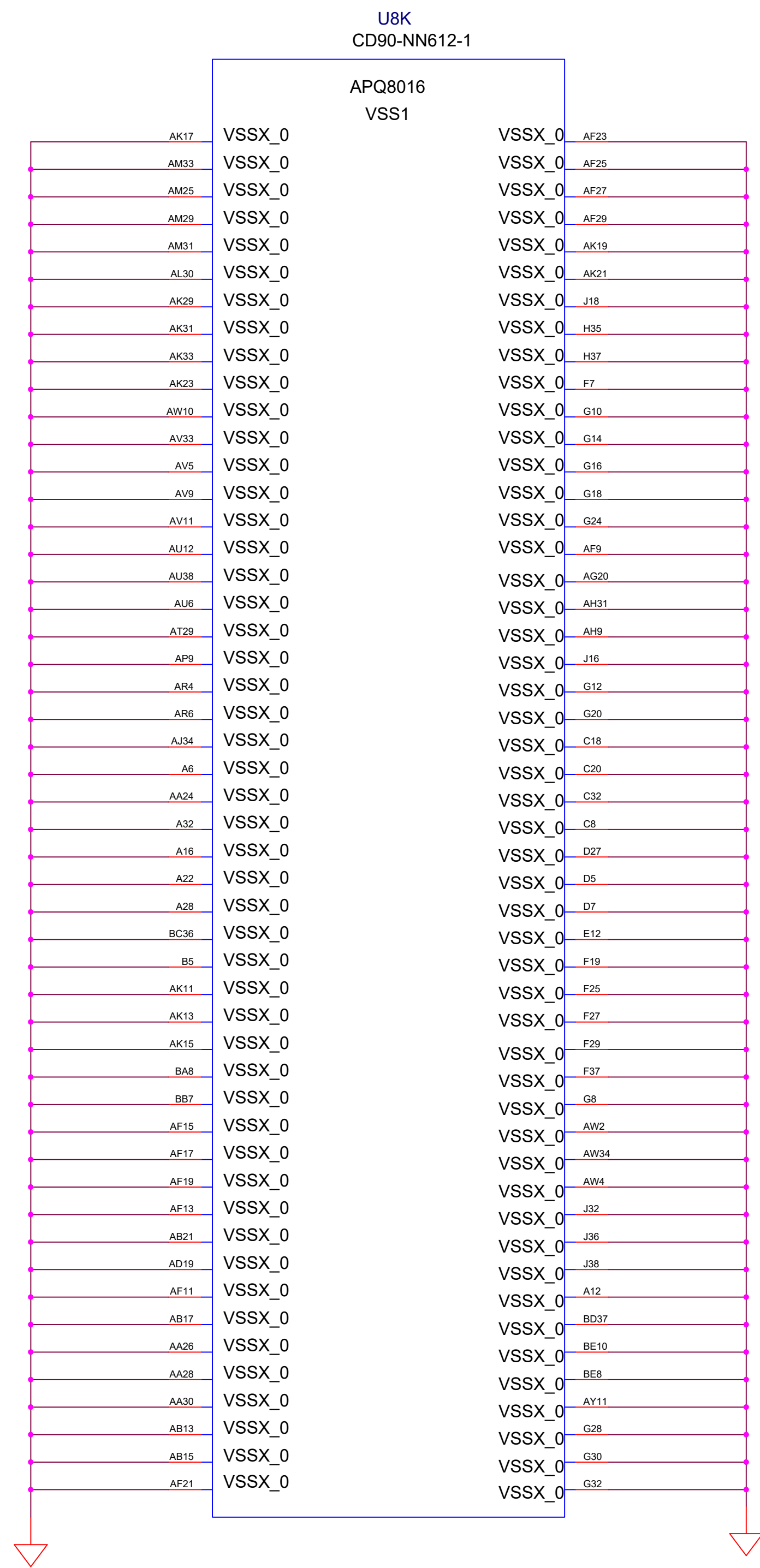

APQ8016 BYPASS CAPACITORS

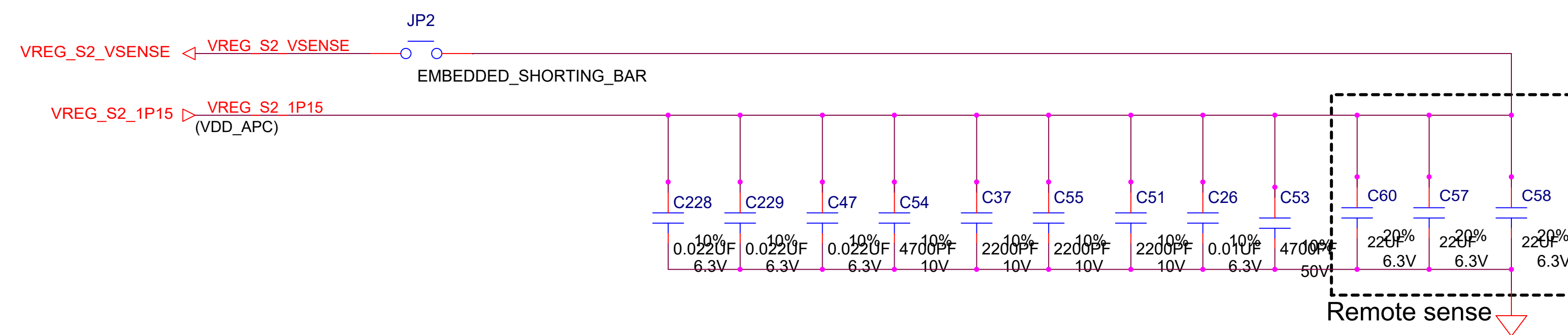
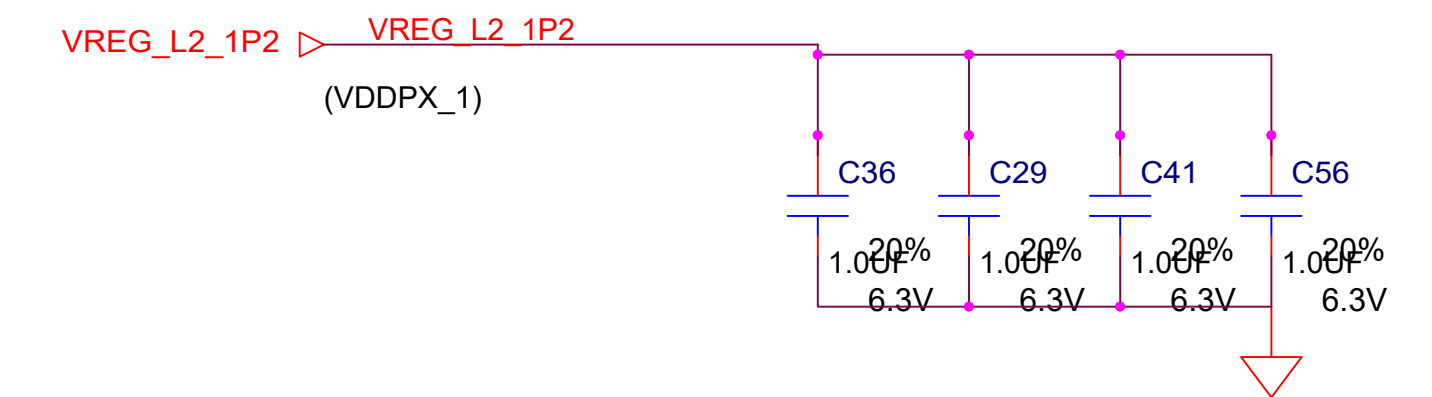
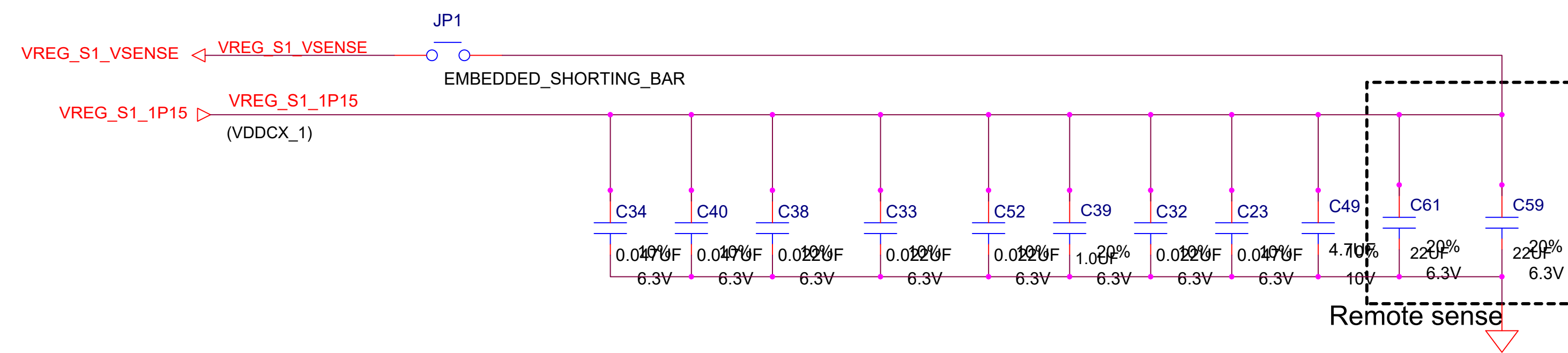
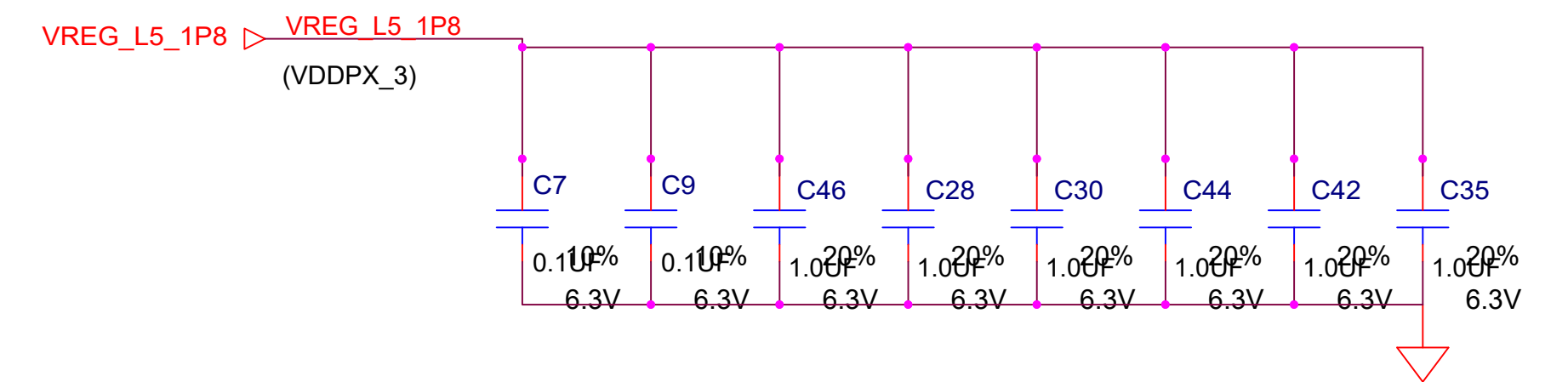
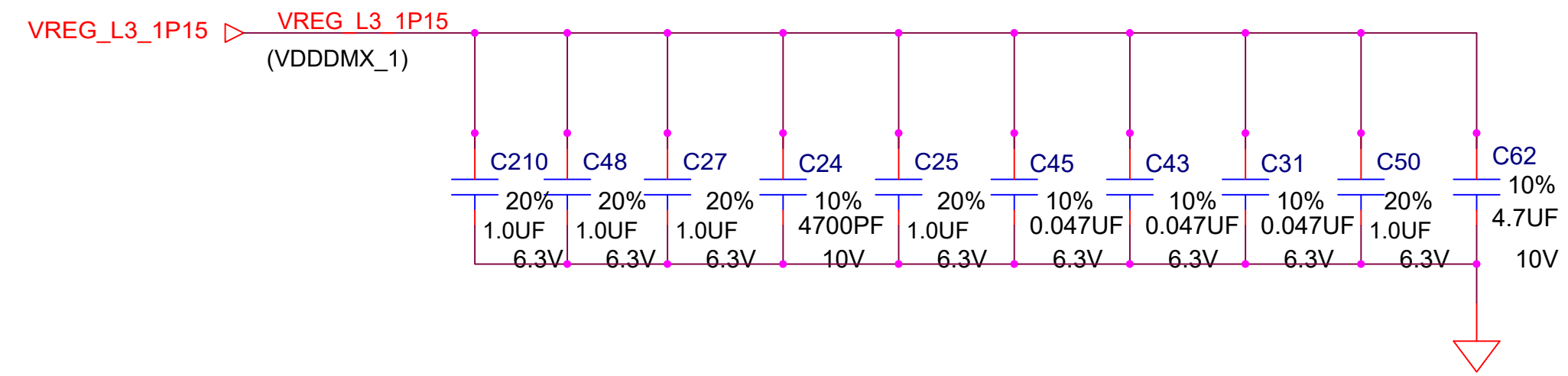

EXTERNAL BUCK REGULATORS

To/From LS EXP CONN

PRE-BUCK - 5.0V

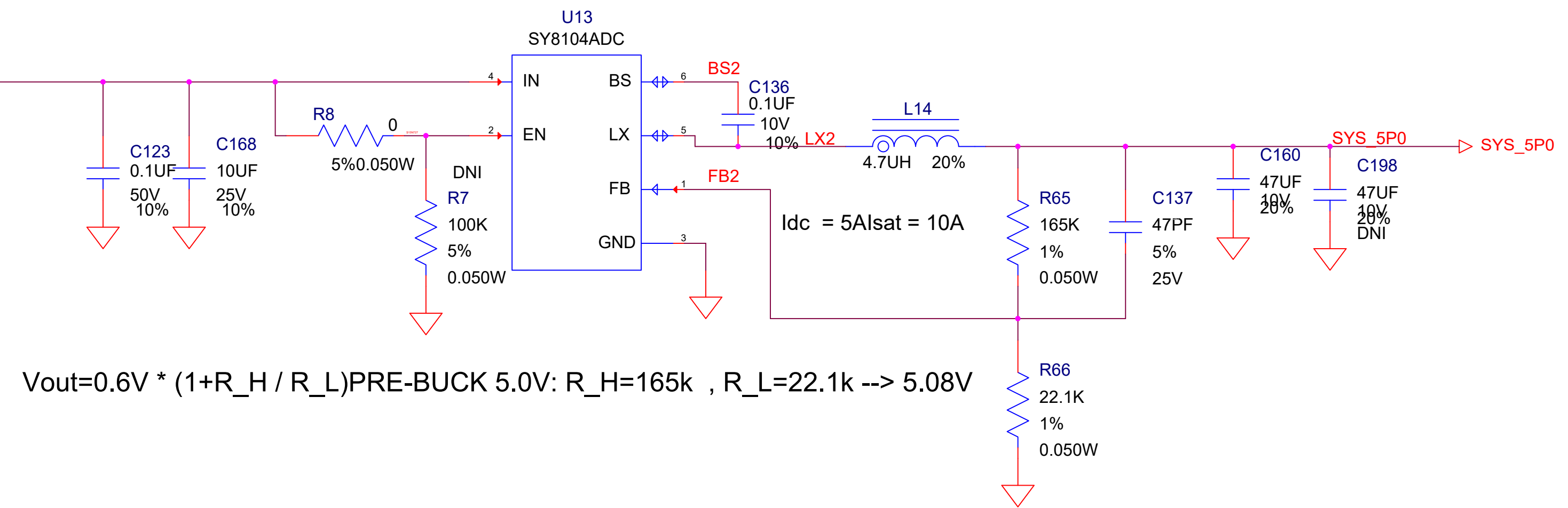

PRE-BUCK - 3.7V

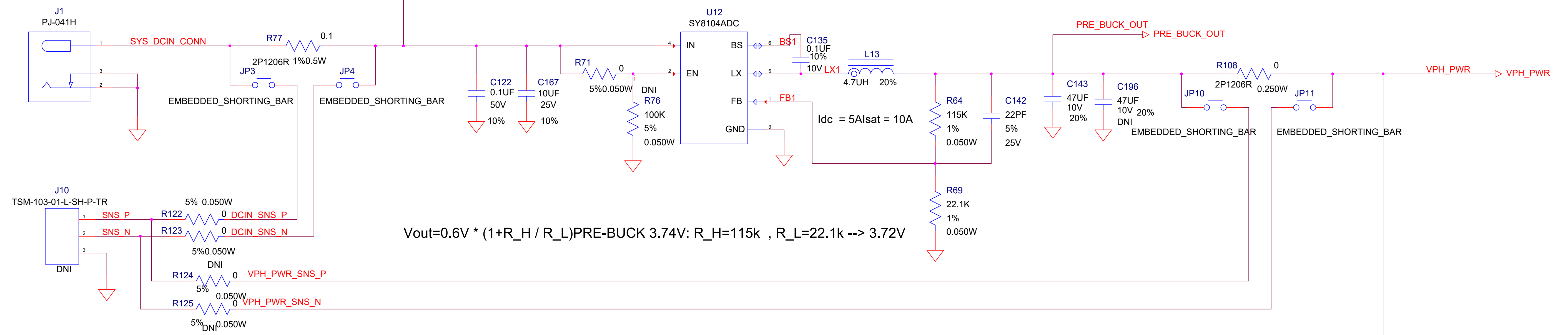

ARM ENERGY PROBE (PWR MEAS)

SUPPORTED	ASSY OPTION
YES	INSTALL J10
NO	DNI J10

VPH_PWR SOURCE

BOM CONFIG	SUPPORTED	ASSY OPTION
Hx0x, HX5X	3.7V BUCK	INSTALL R108 DNI J14, R136
NONE	BATTERY	DNI R108 INSTALL J14, R136

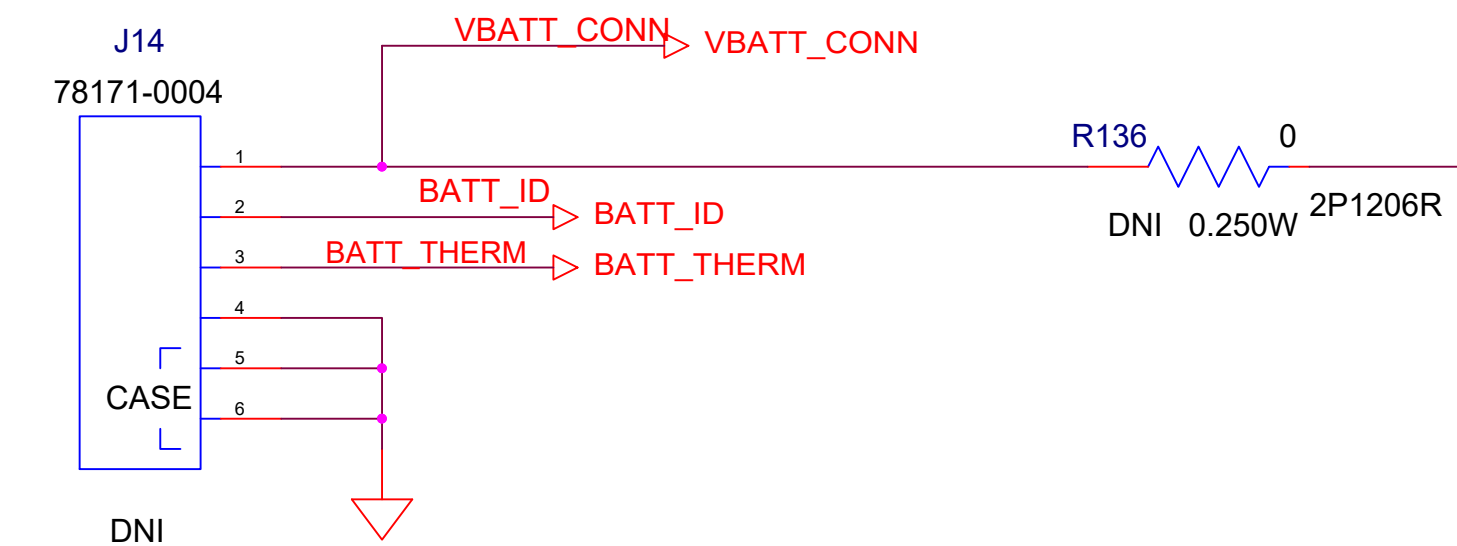

PM8916 - CONTROL/CLOCKS

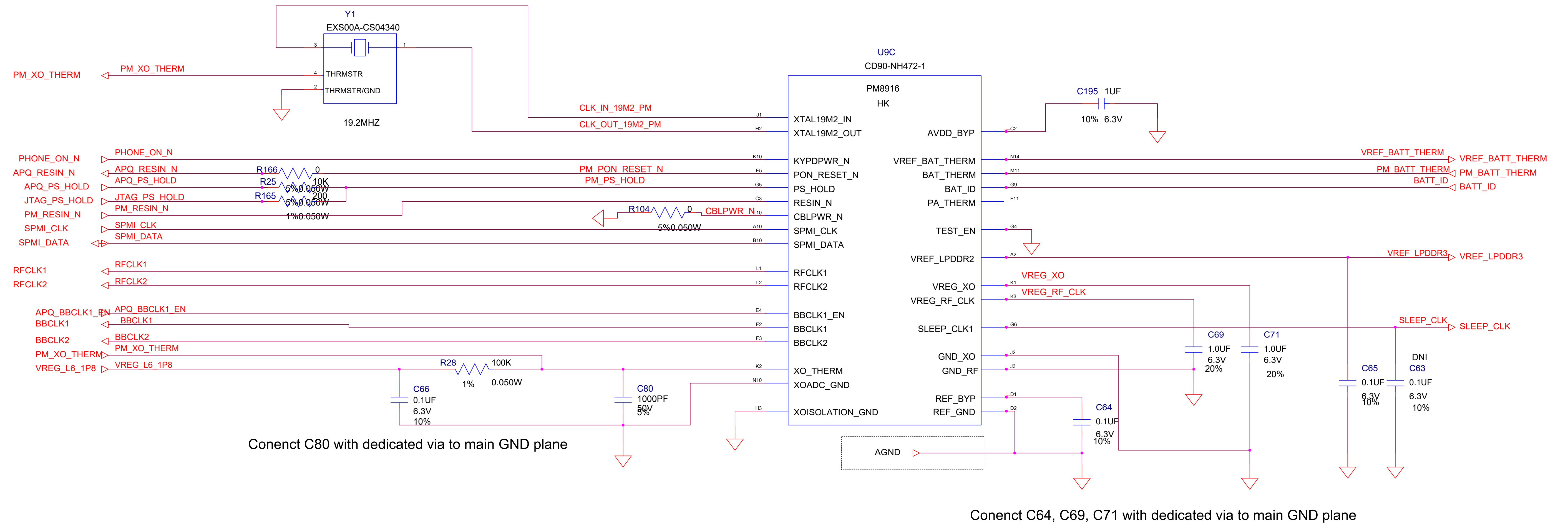

VPH_PWR SOURCE

BOM CONFIG	SUPPORTED	ASSY OPTION
Hx0x, HX5X	3.7V BUCK	INSTALL R134,R135
NONE	BATTERY	DNI R134,R135

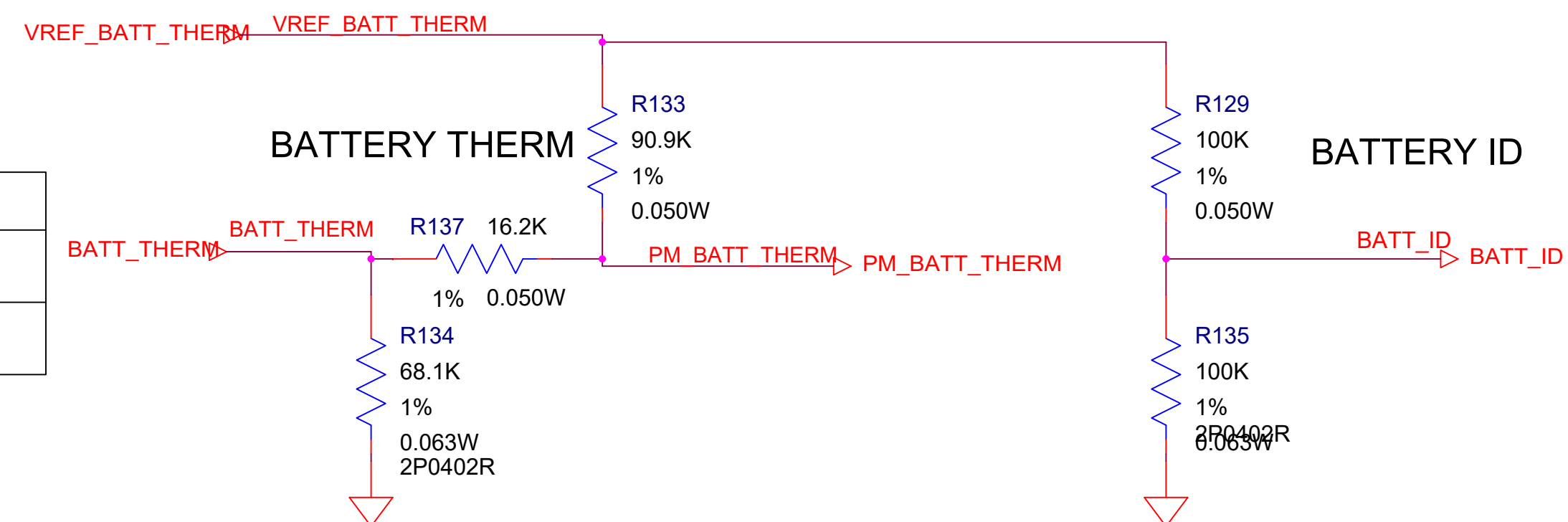

PM8916 - CHARGER/GPIOS/MPPS

VPH_PWR SOURCE

BOM CONFIG	SUPPORTED	ASSY OPTION
Hx0x, HX5X	3.7V BUCK	INSTALL R106,R88 DNI R130
NONE	BATTERY	DNI R106,R88 INSTALL R130

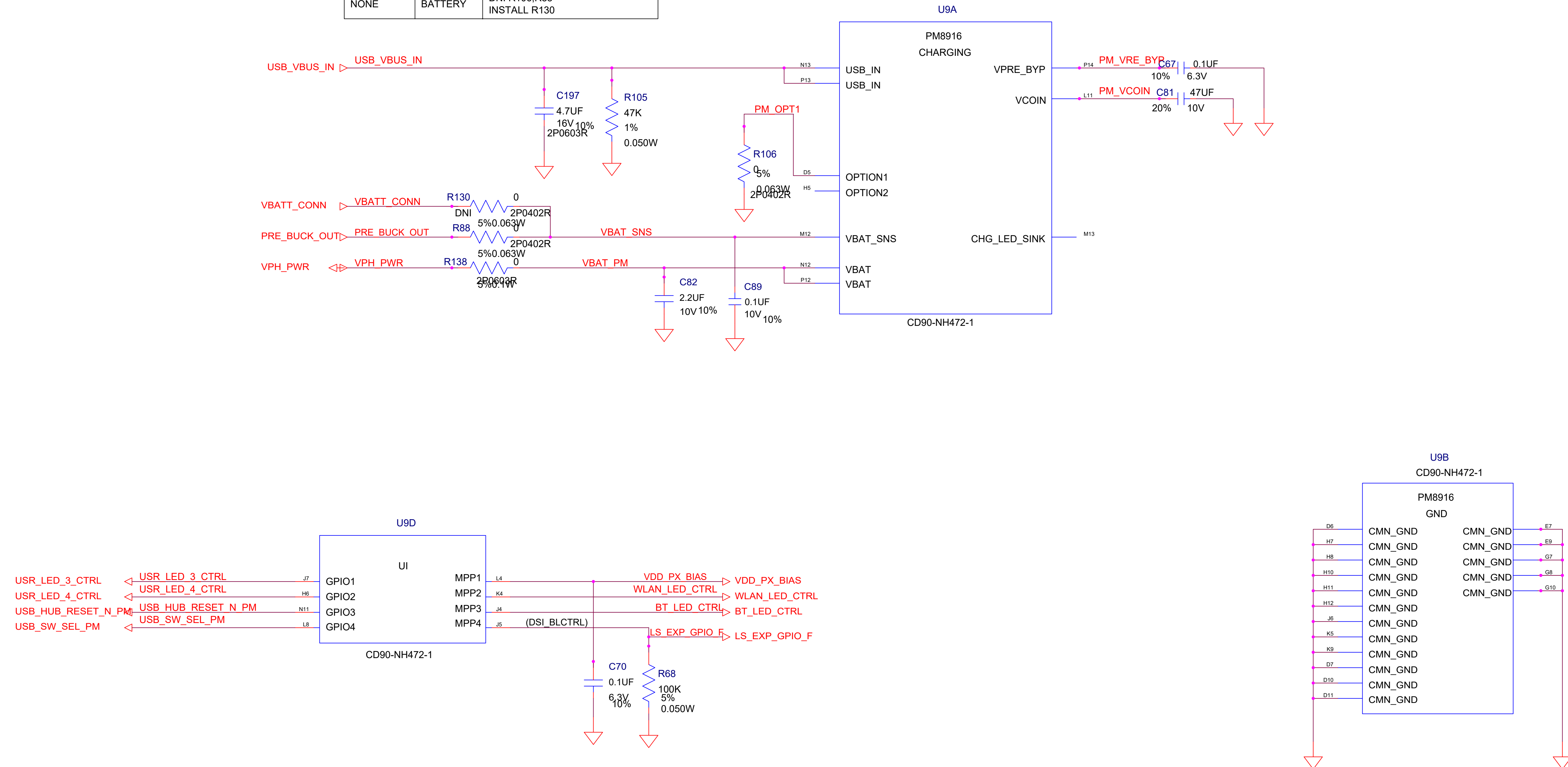

PM8916 - SMPS

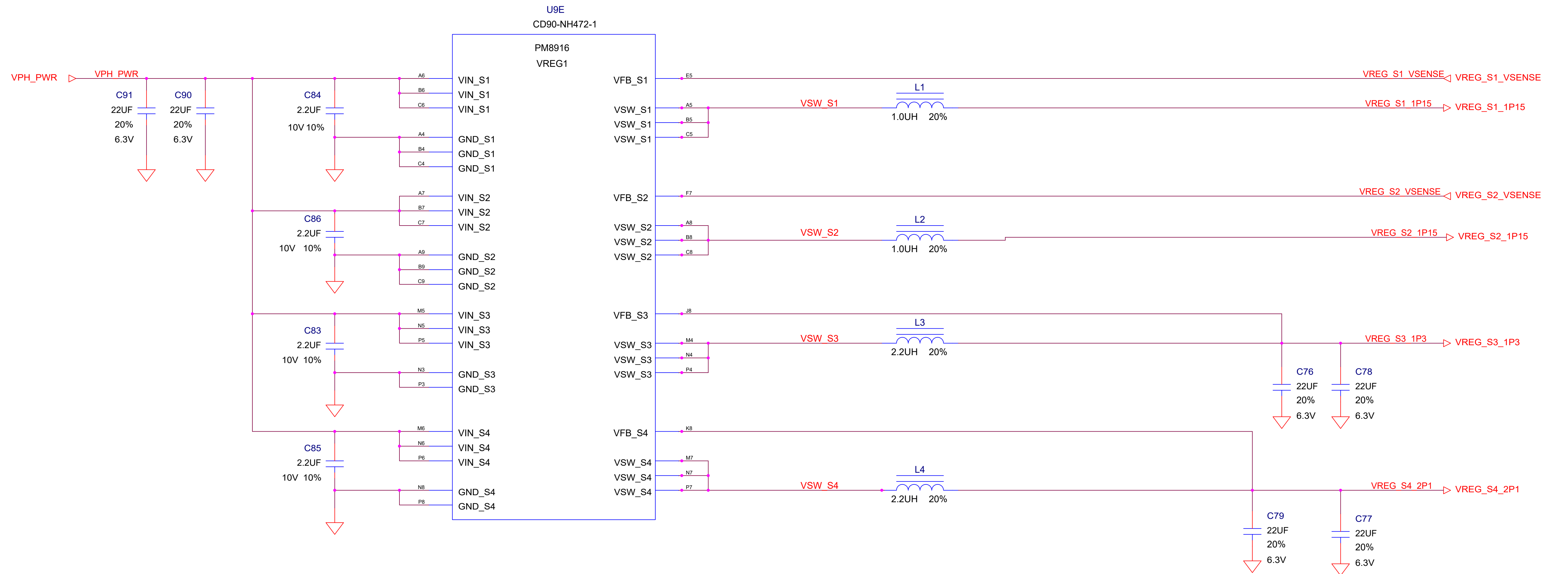

PM8916 - LDOs

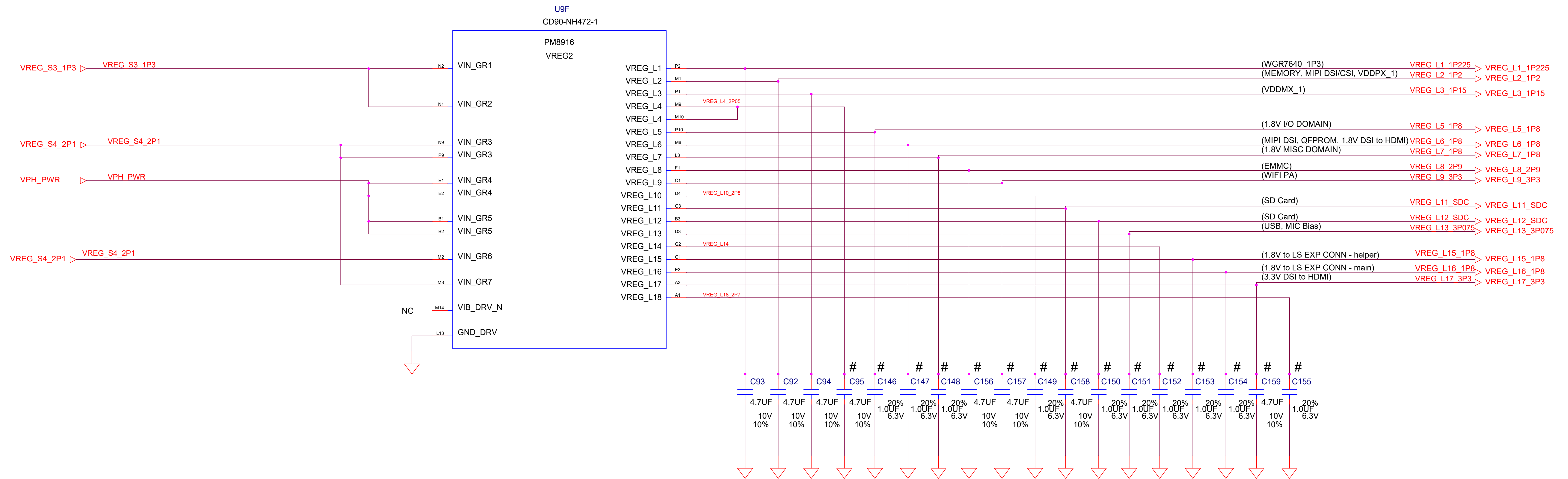

NOTES:

Effective output capacitance LDOs L1, L2, L3, L4, L8, L9, L11, L17 --> Cout_eff = 4.7uF LDOs L5, L6, L7, L10, L12, L13, L14, L15, L16, L18 --> Cout_eff = 1.0uF

PSEUDO CAPLESS LDOs (indicated by # near the capacitor) L4, L5, L6, L7, L8, L9, L10, L11, L12, L13, L14, L15, L16, L17, L18

PSEUDO CAPLESS LDOs capacitors location is defined in 80-NK808-21

PM8916 - AUDIO

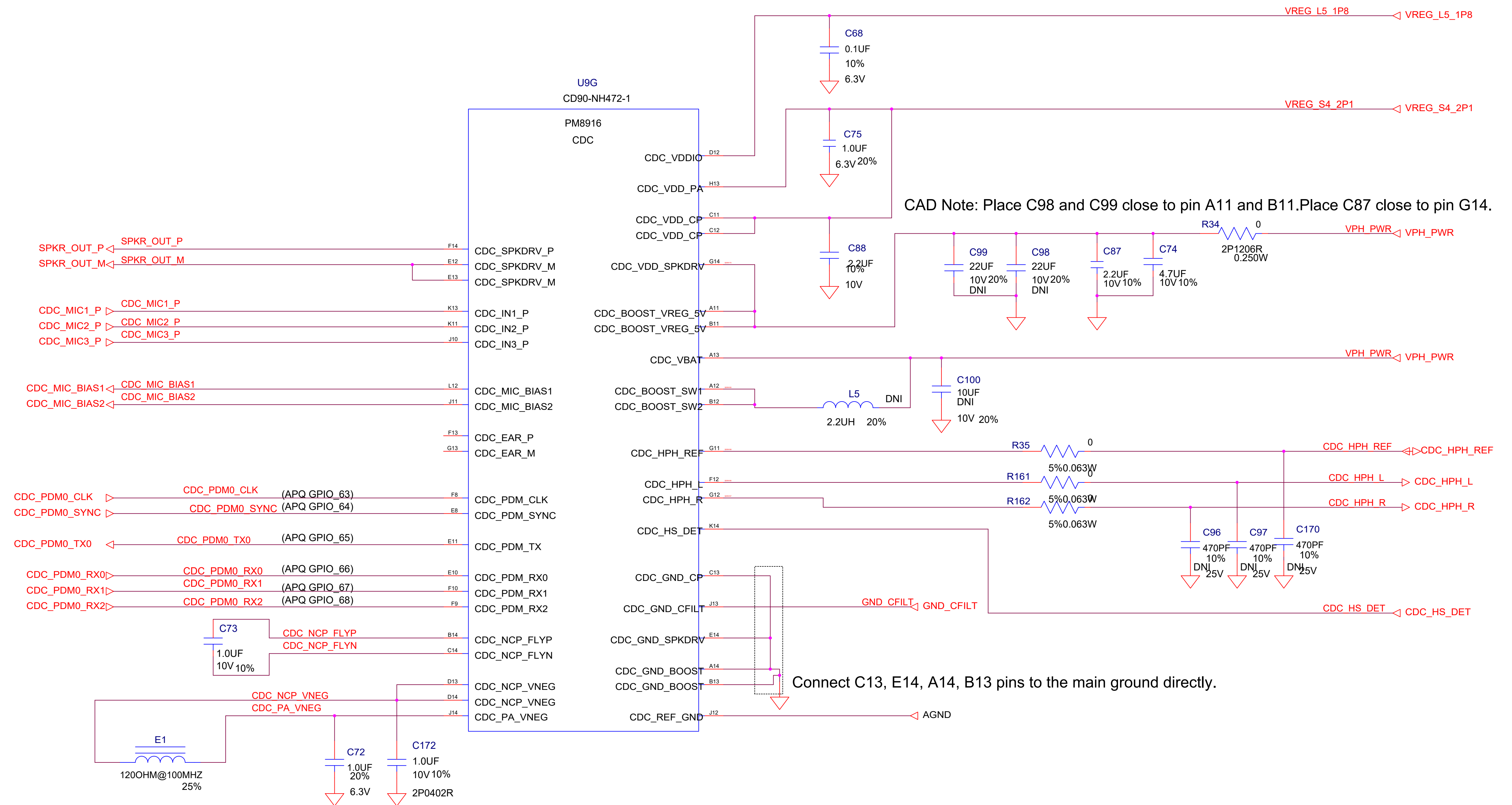

ANALOG MIC

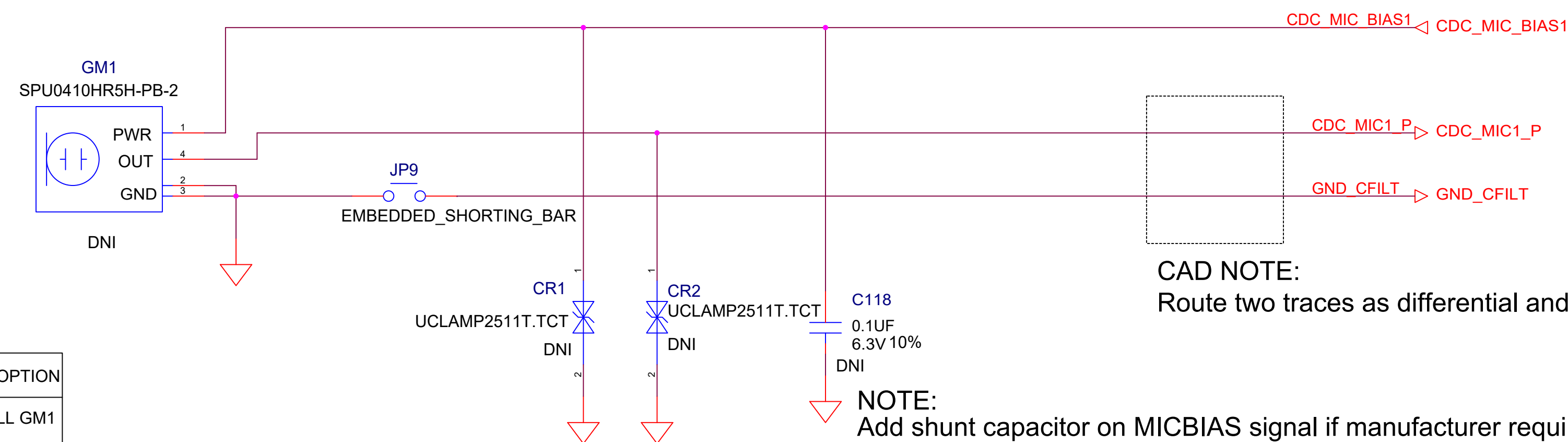

ANALOG MIC

SUPPORTED	ASSY OPTION
YES	INSTALL GM1
NO	DNI GM1

MEMORY - LPDDR3 + EMMC - CONTROL

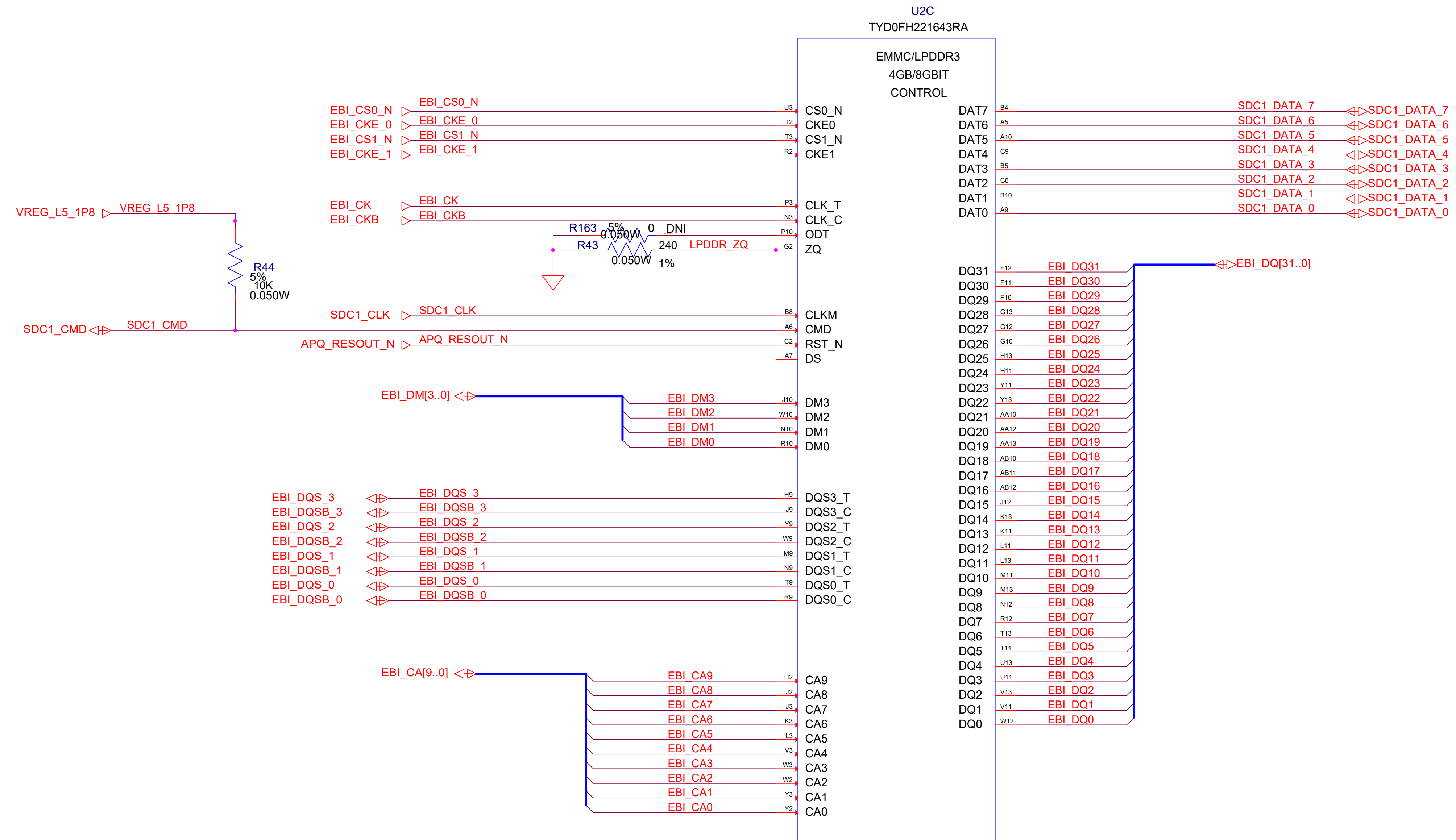

MEMORY - LPDDR3 + EMMC - CONTROL

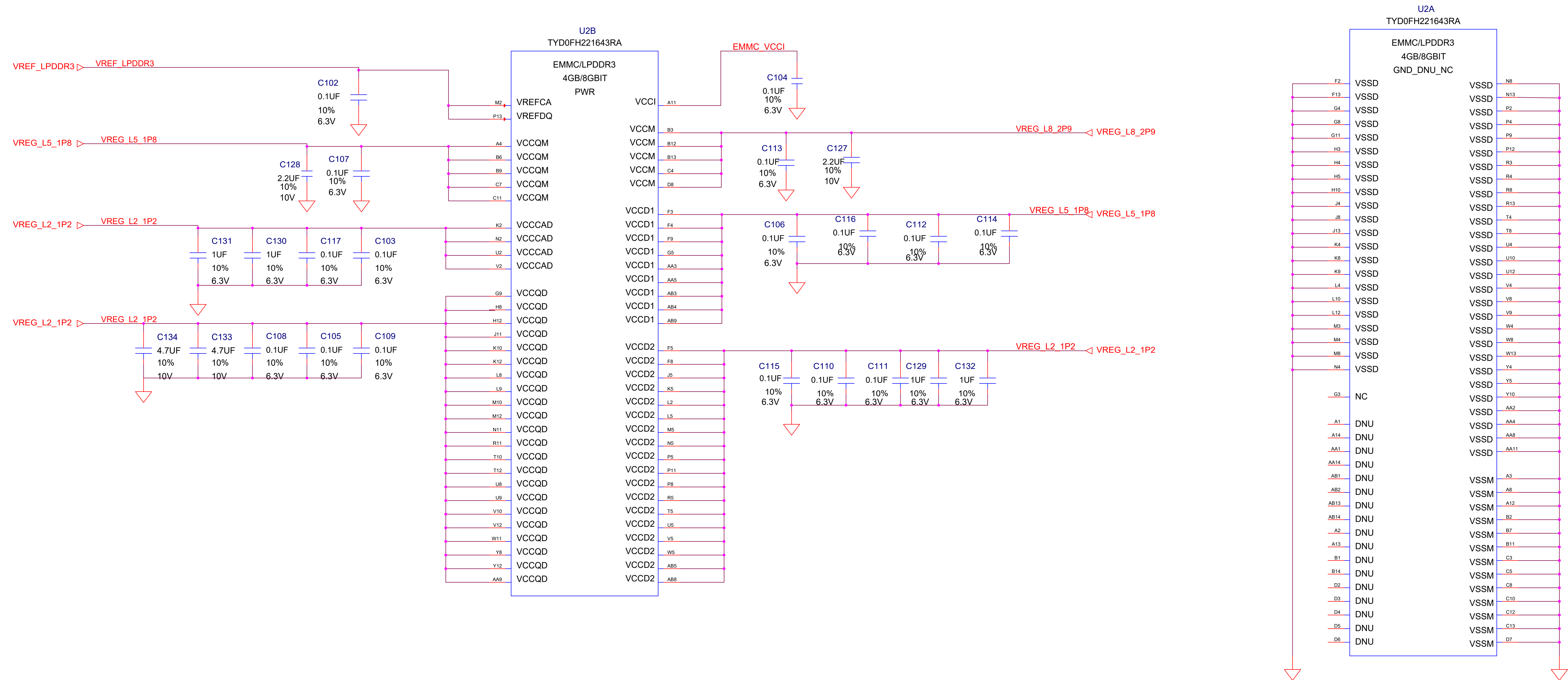

MEMORY - uSD CONNECTOR

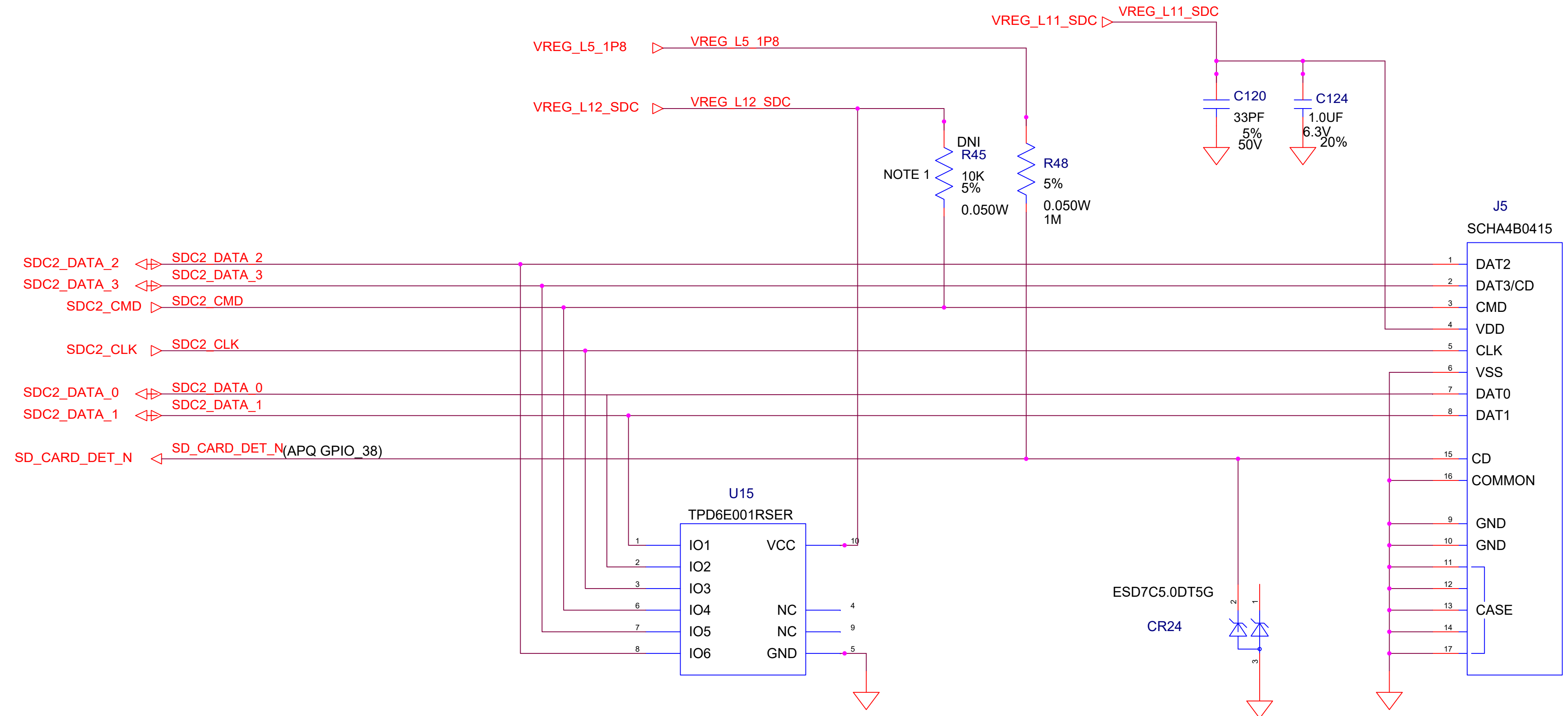

CARD DETECT	CASE
CARD NOT INSTALLED	CD-COMMON SW=OFF
CARD INSTALLED	CD-COMMON SW=ON

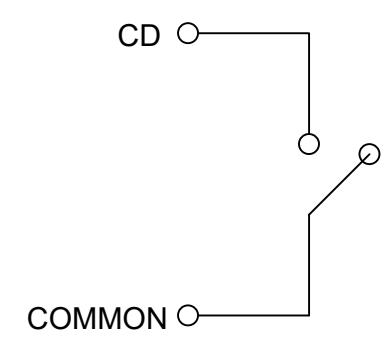

USB - SWITCH / HUB

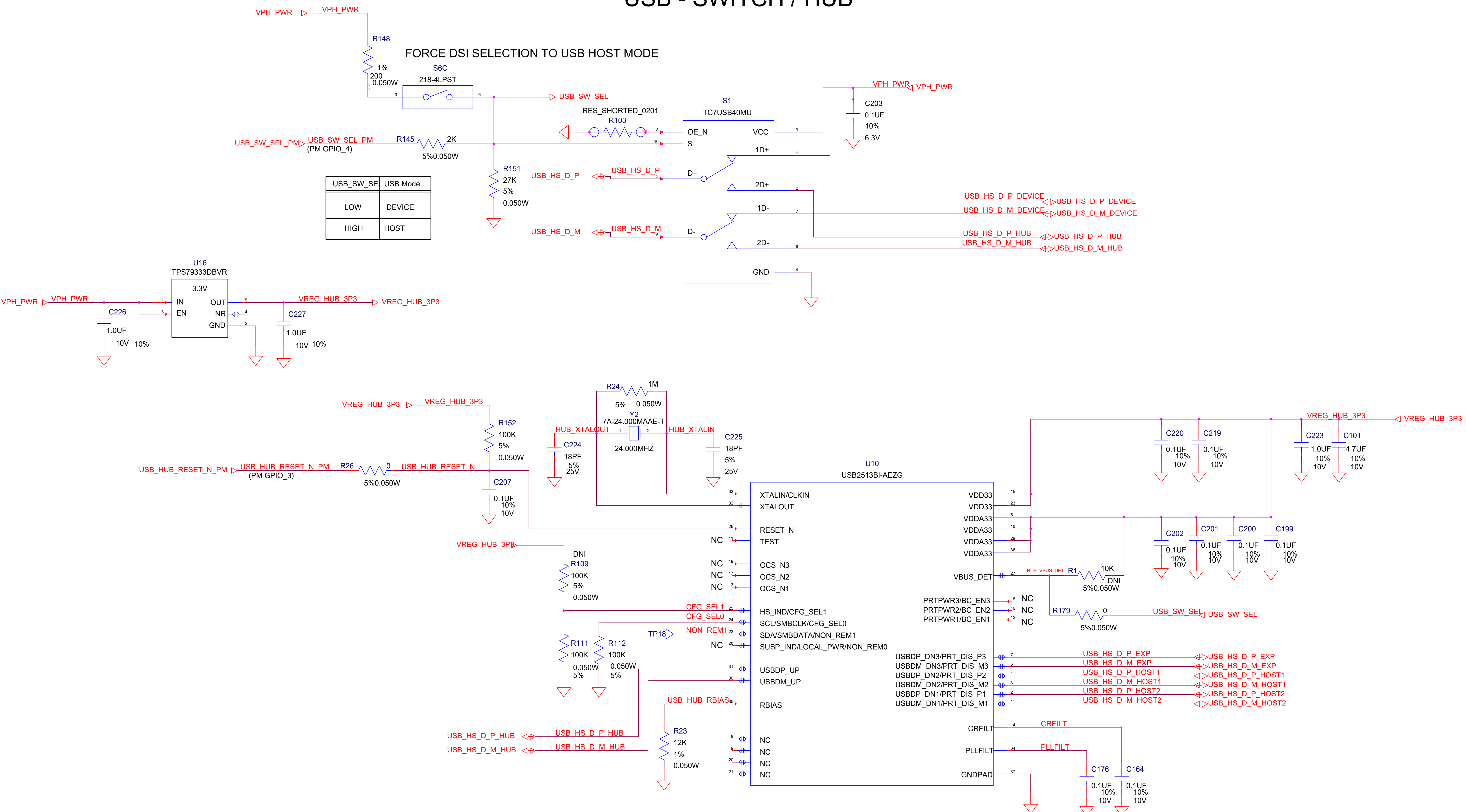

Note 1:
REF_SEL[1:0] = '10' --> REFVLK=19.2MHz

USB - CONNECTORS

USB2.0 uB - DEVICE

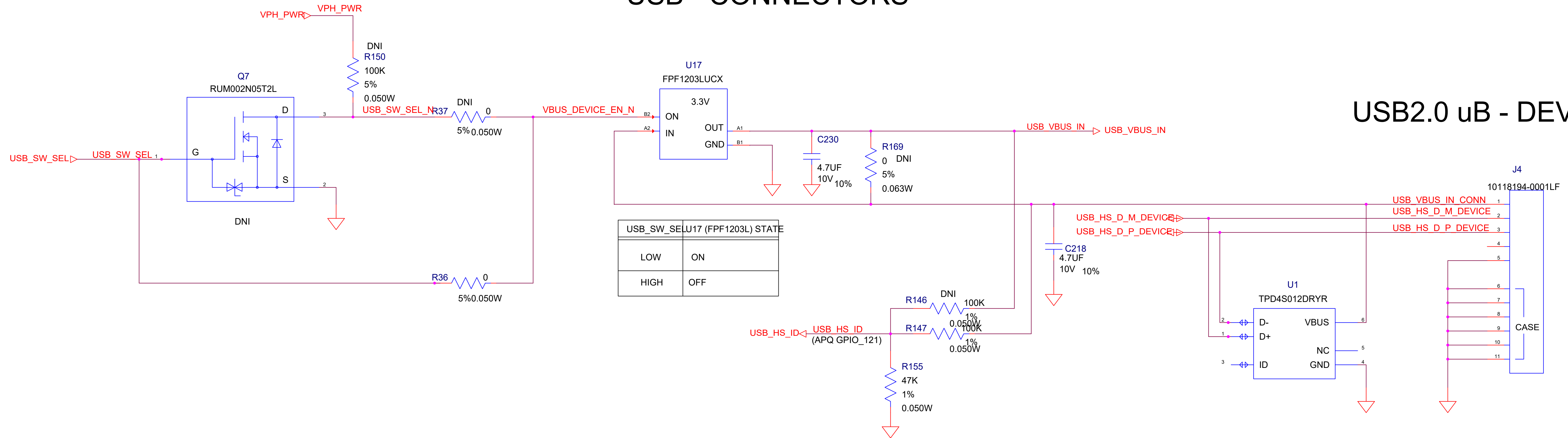

USB2.0 Type A - HOST1

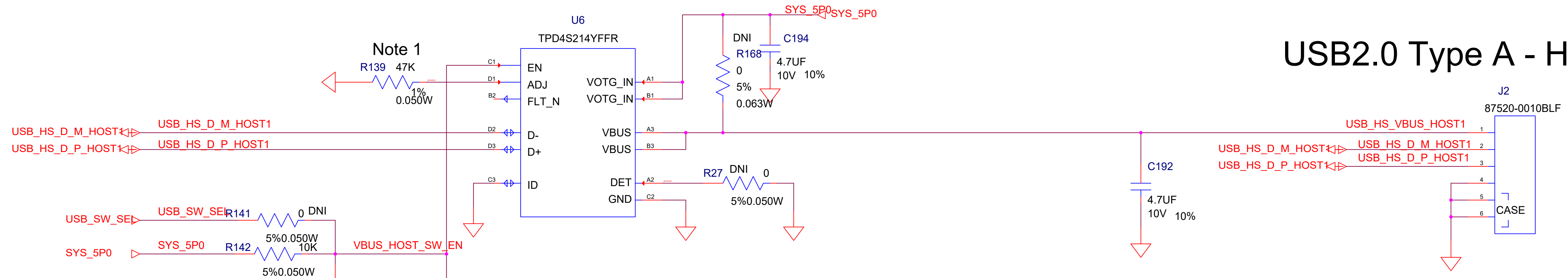

USB2.0 Type A - HOST2

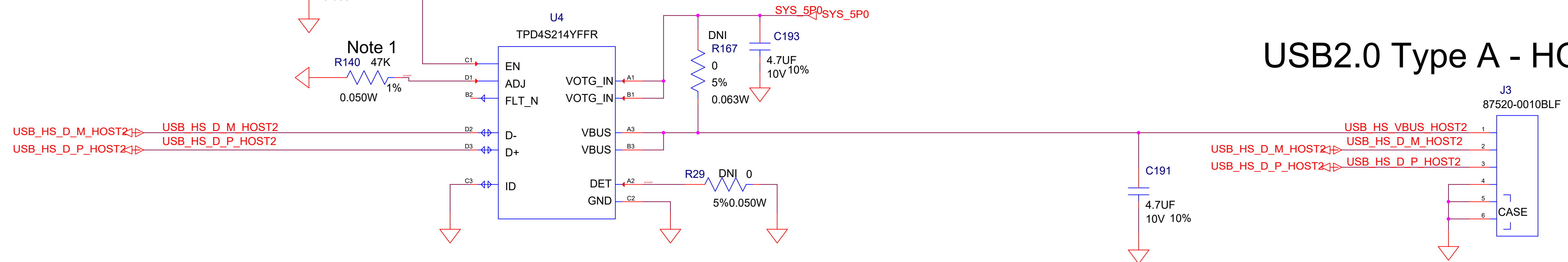

Notes: 1. Current Limit = $55.358 / \text{Radj} [\text{komh}] = 1.18\text{mA}2$. Connect USB ID pin on connector when uAB conenctor is used (10104111)

DISPLAY - DSI SWITCH

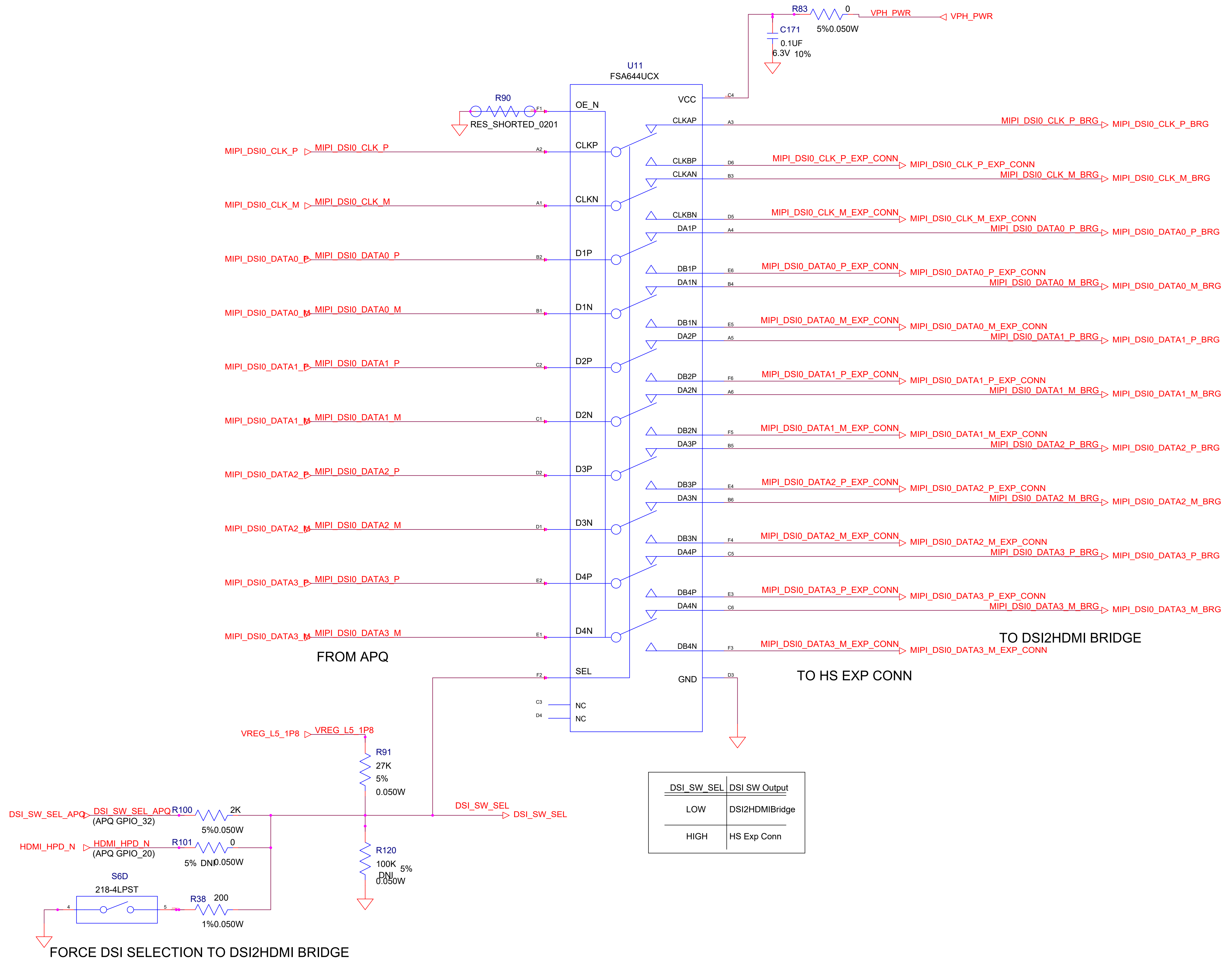

DISPLAY - DSI TO HDMI BRIDGE

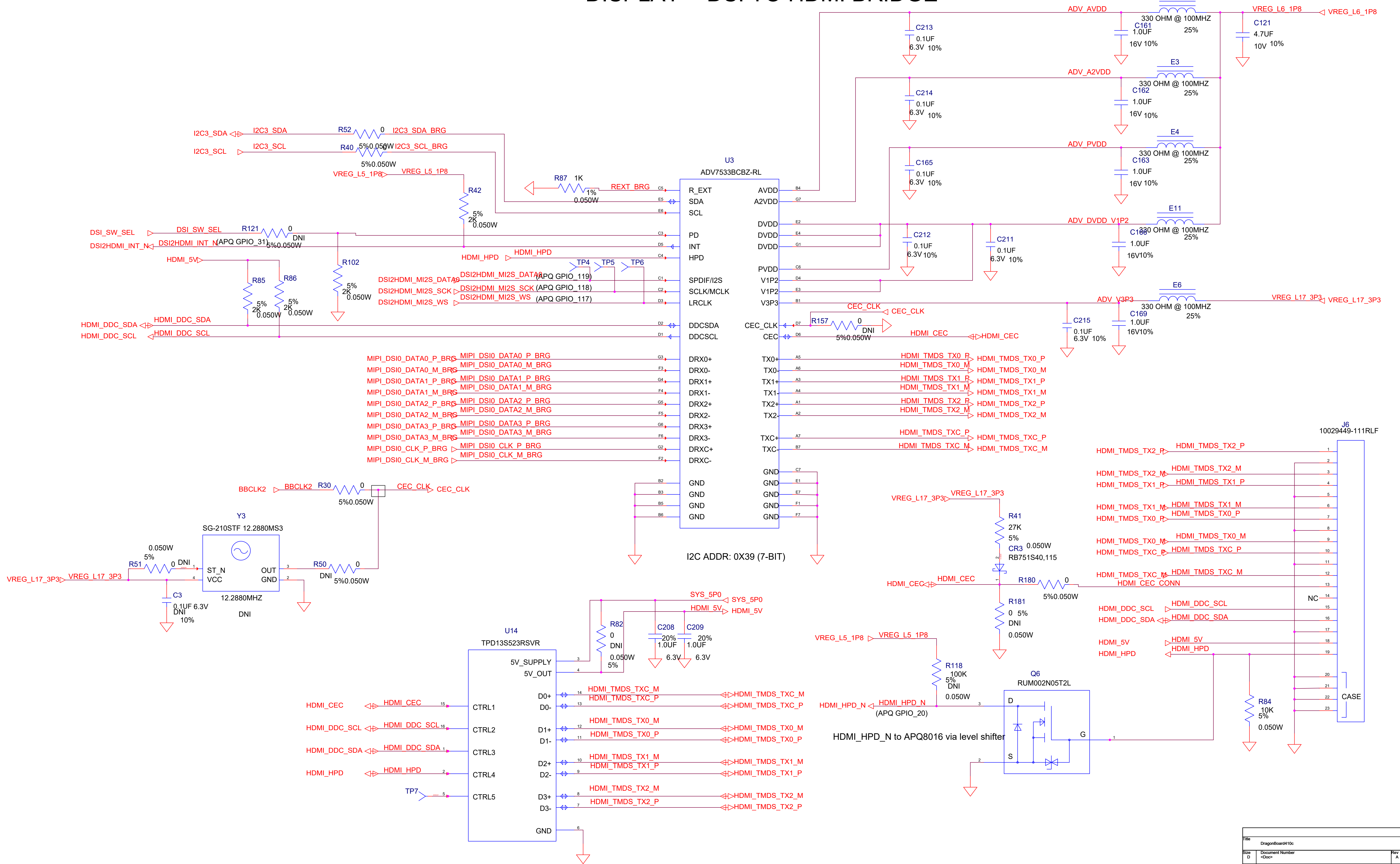

SWITCHES / LEDS

USER LED 1

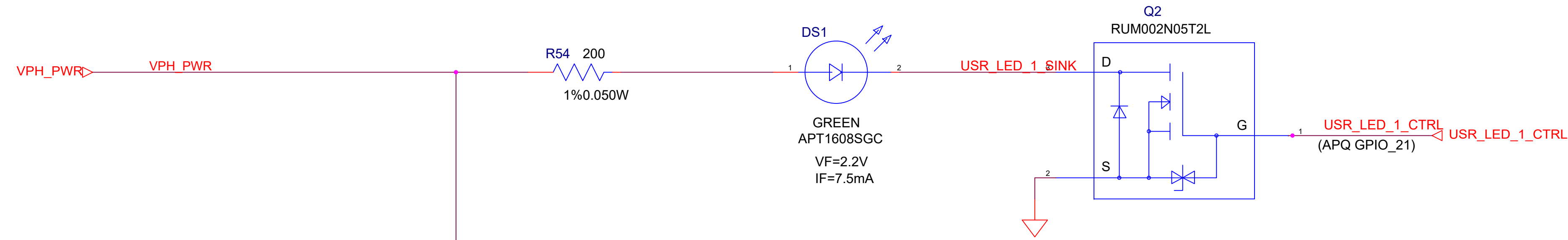

USER LED 2

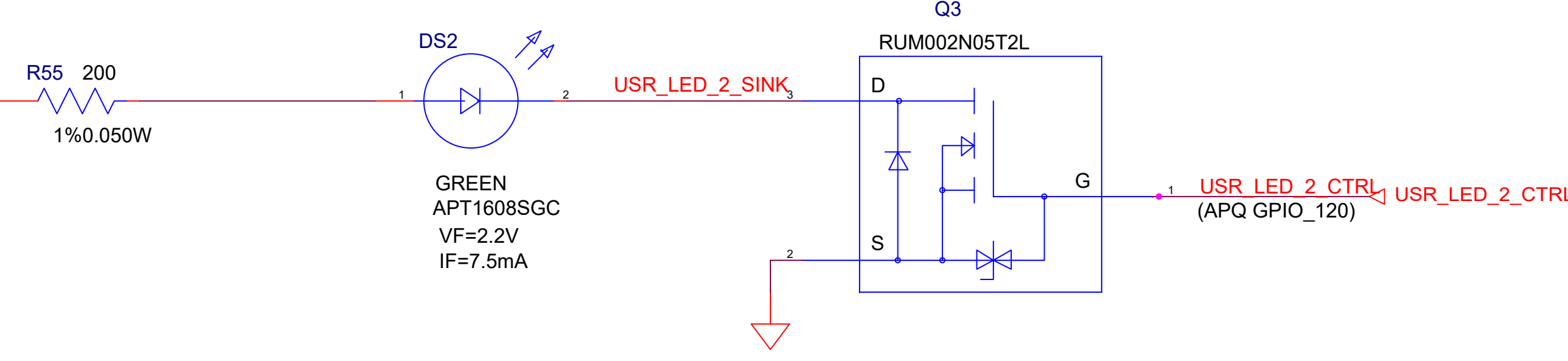

USER LED 3

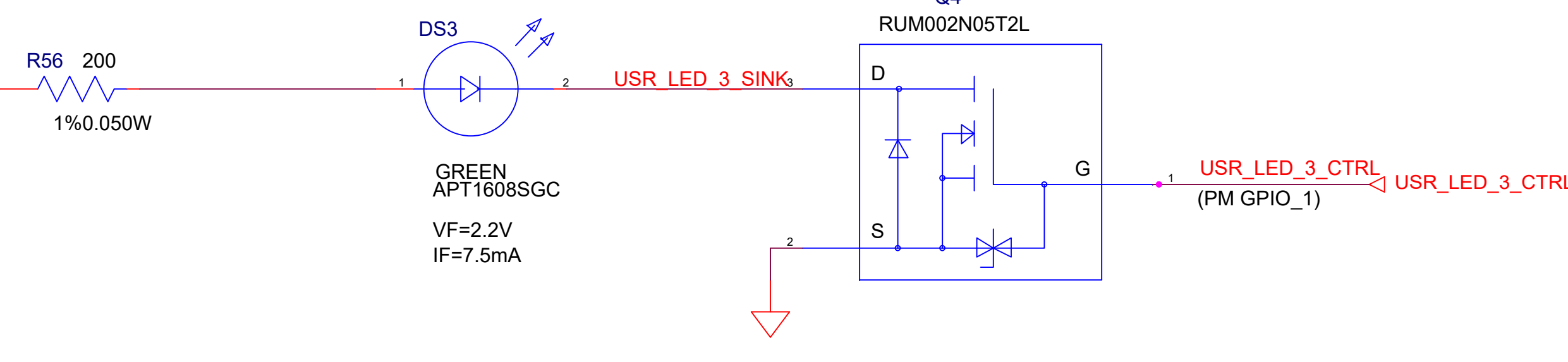

USER LED 4

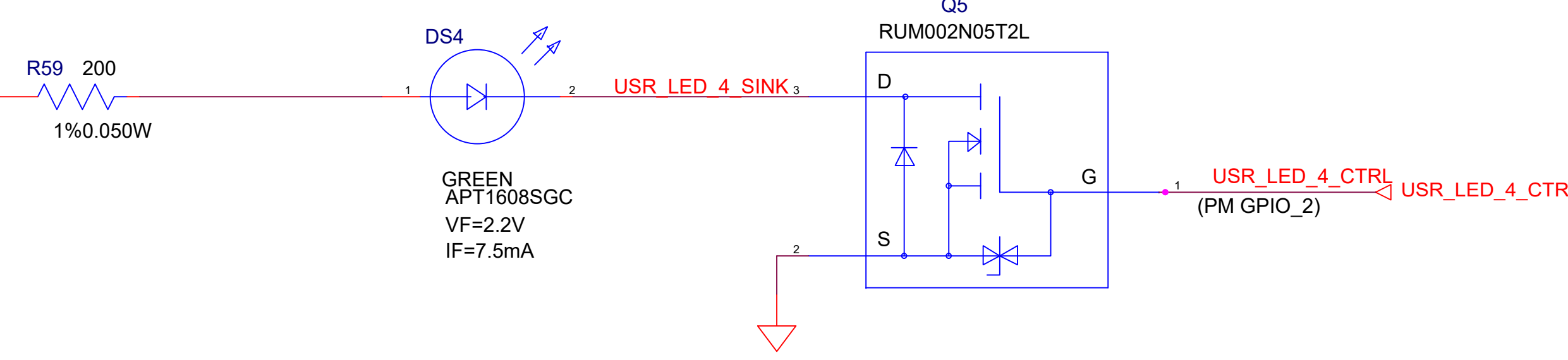

WLAN ACTIVE LED

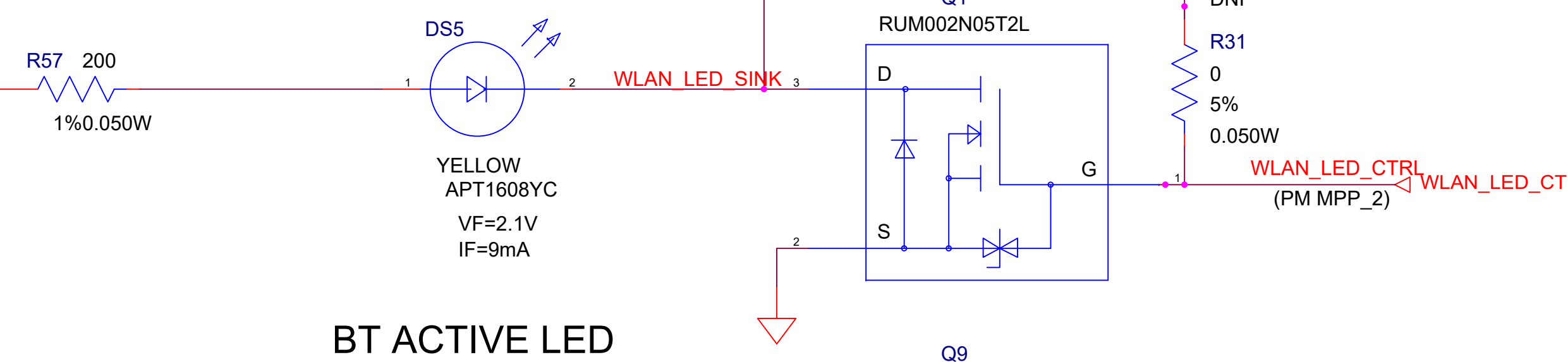

BT ACTIVE LED

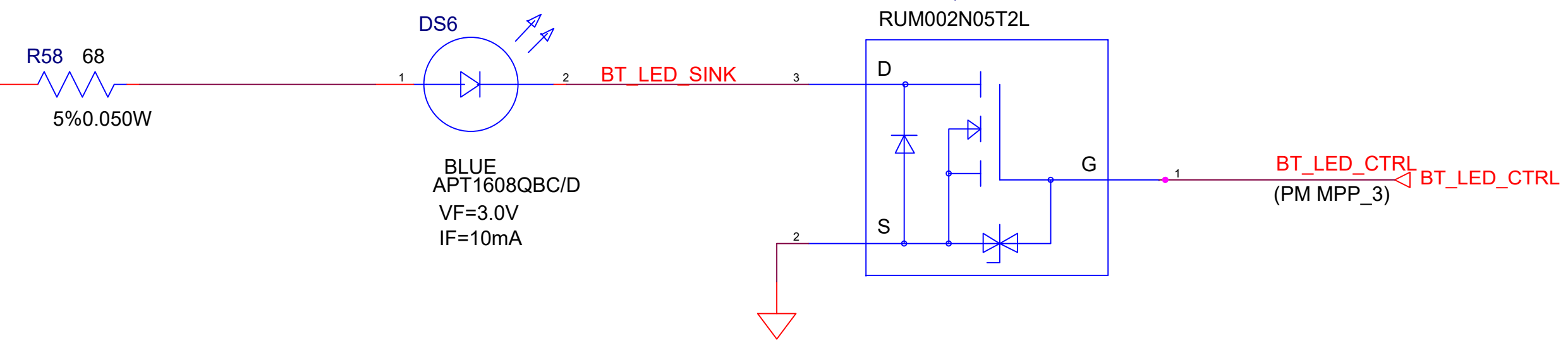

PWR SWITCH

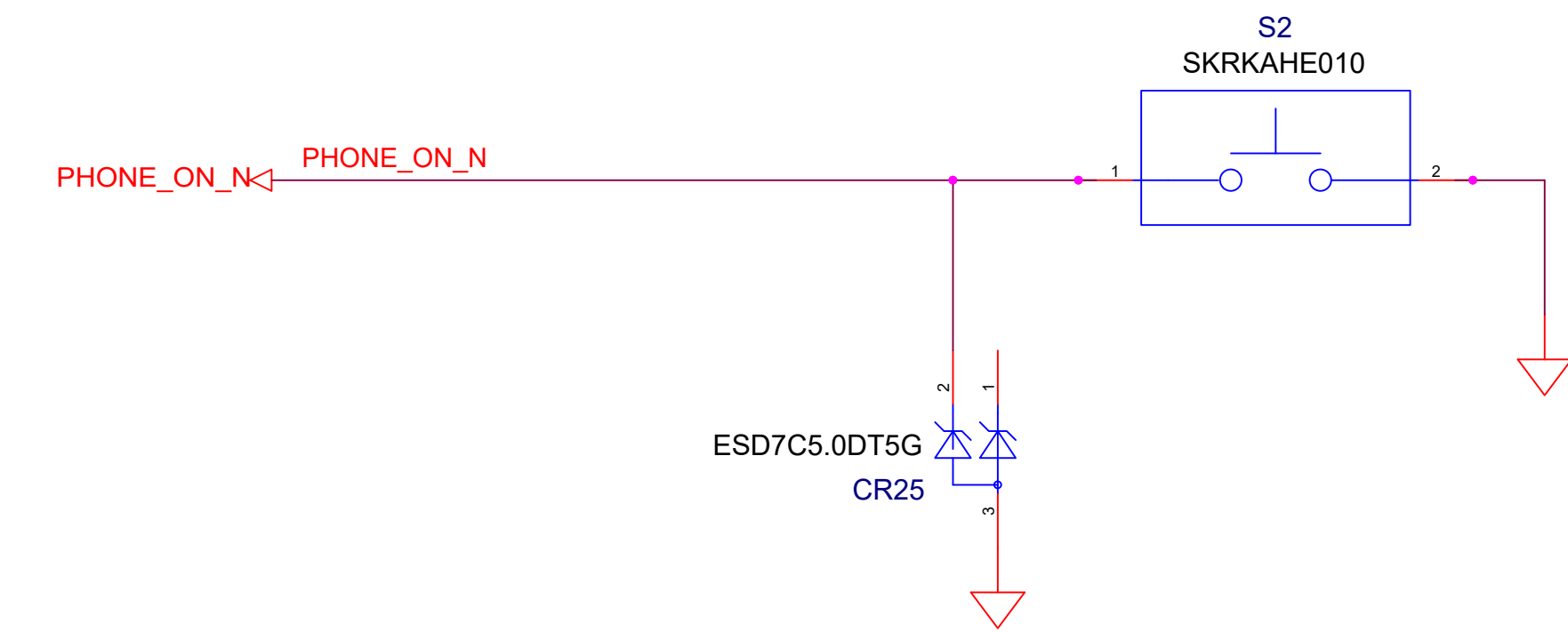

VOL/ZOOM+

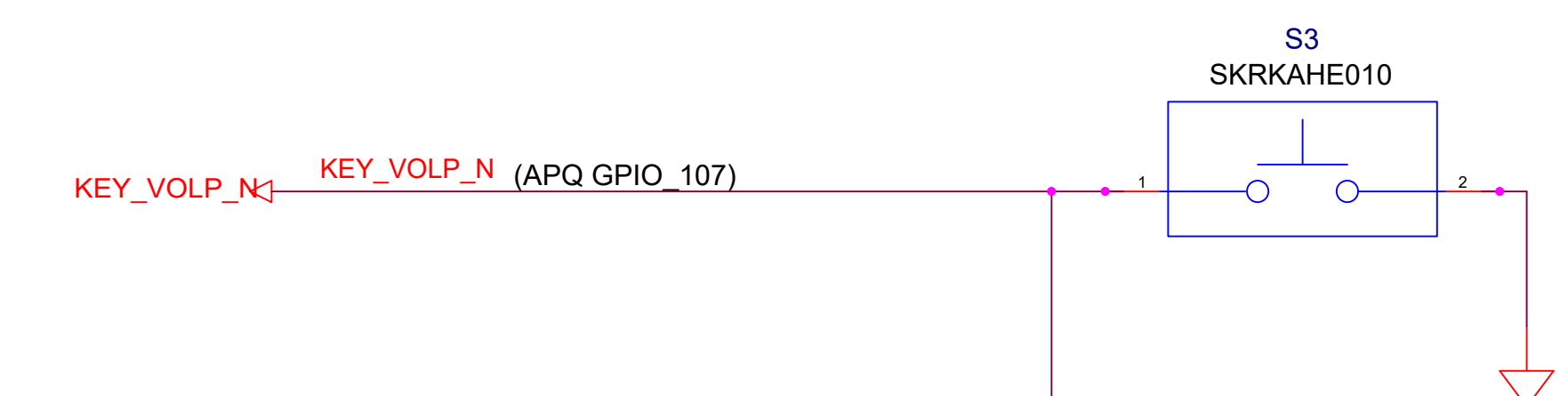

VOL/ZOOM-

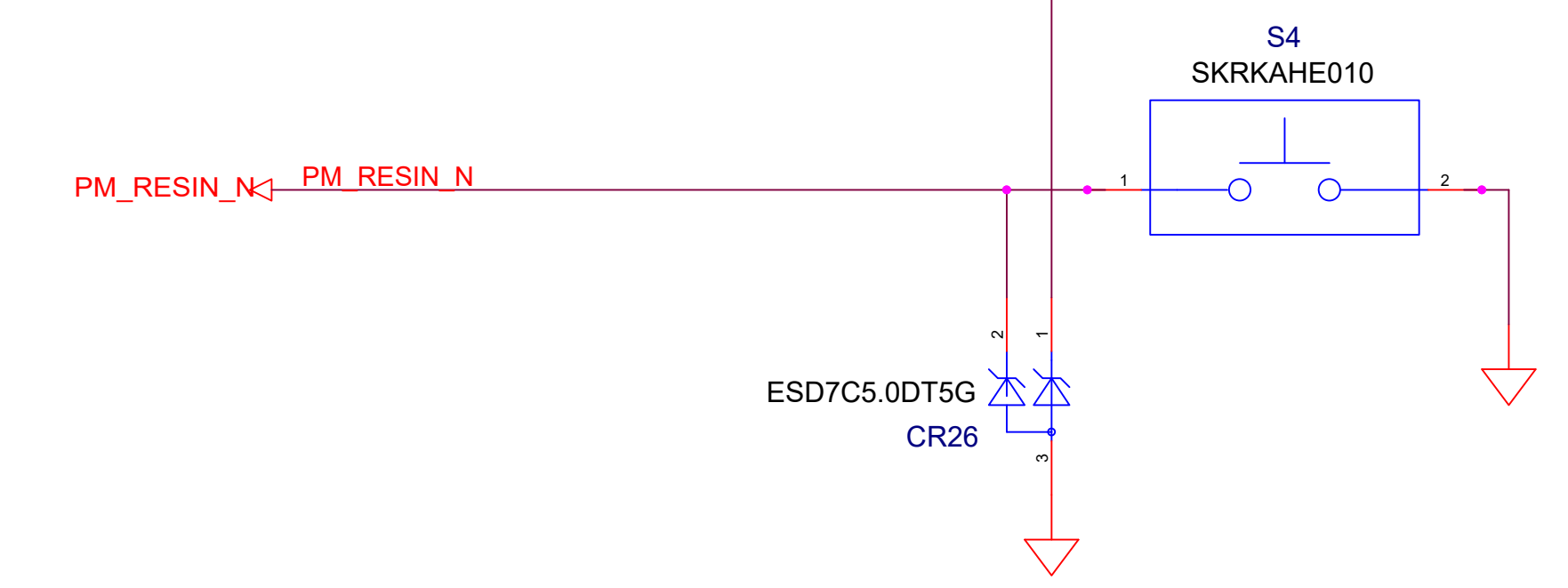

LS / HS EXPANSION CONNECTORS

HS EXPANSION CONNECTOR

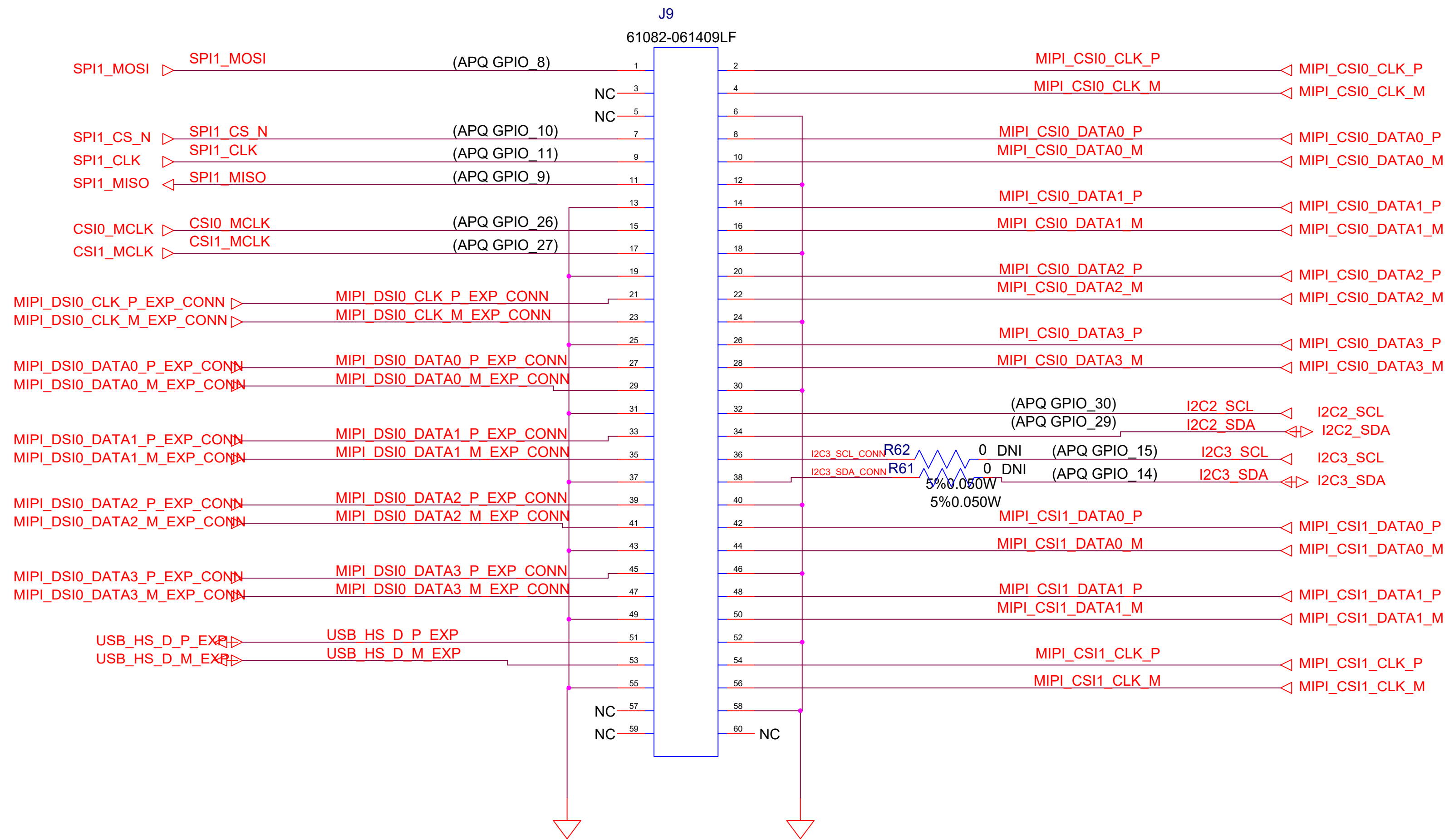

LS EXPANSION CONNECTOR

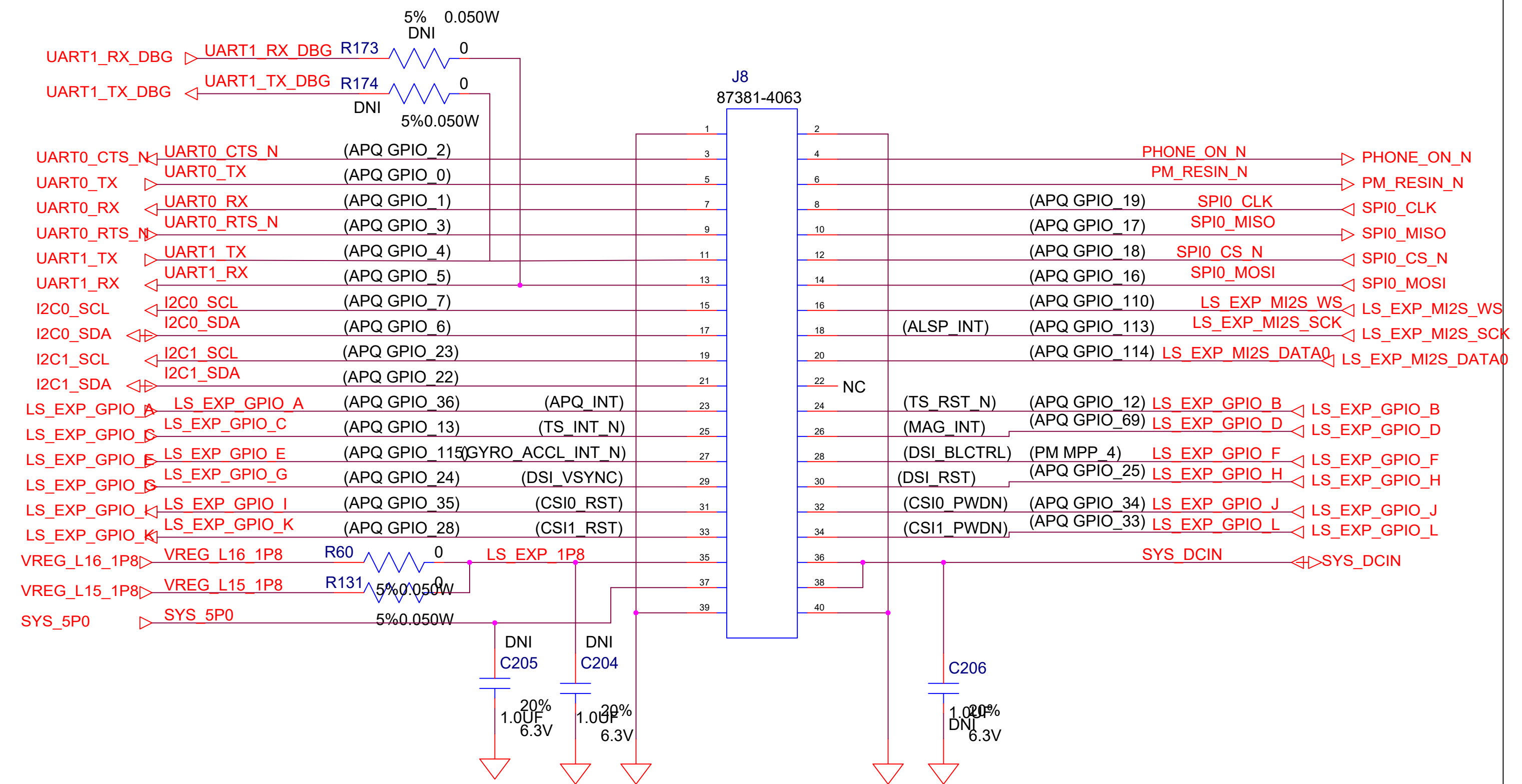

JTAG / UART / ANALOG EXPANSION CONNECTORS

JTAG INTERFACE (TOP)

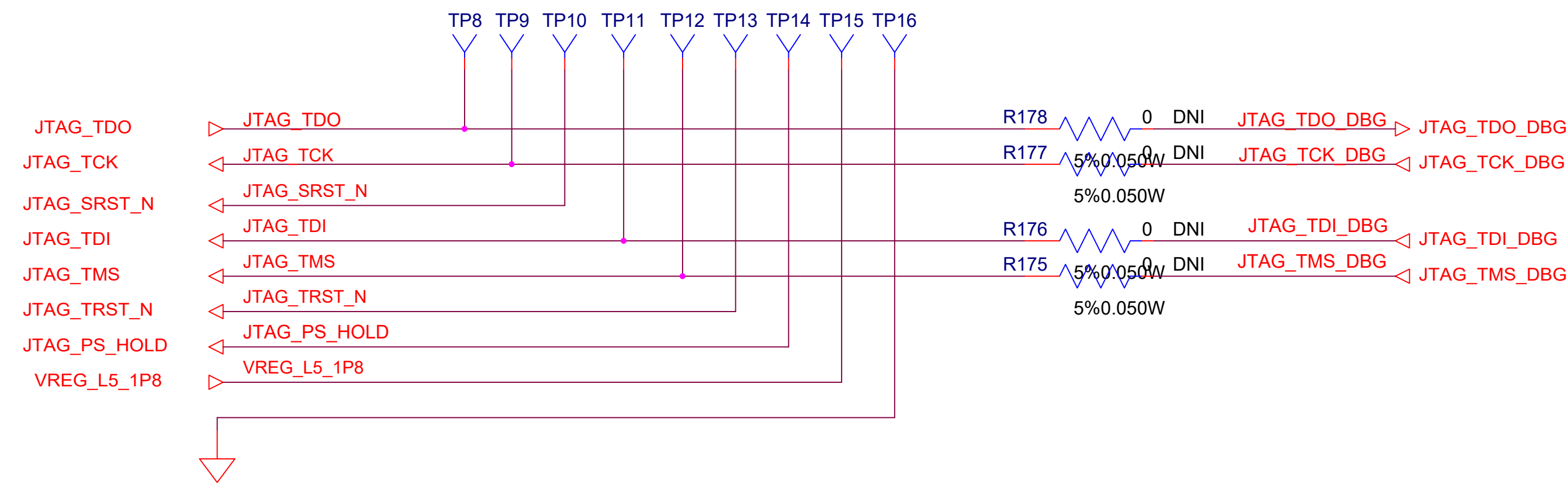

ANALOG EXPANSION CONNECTOR

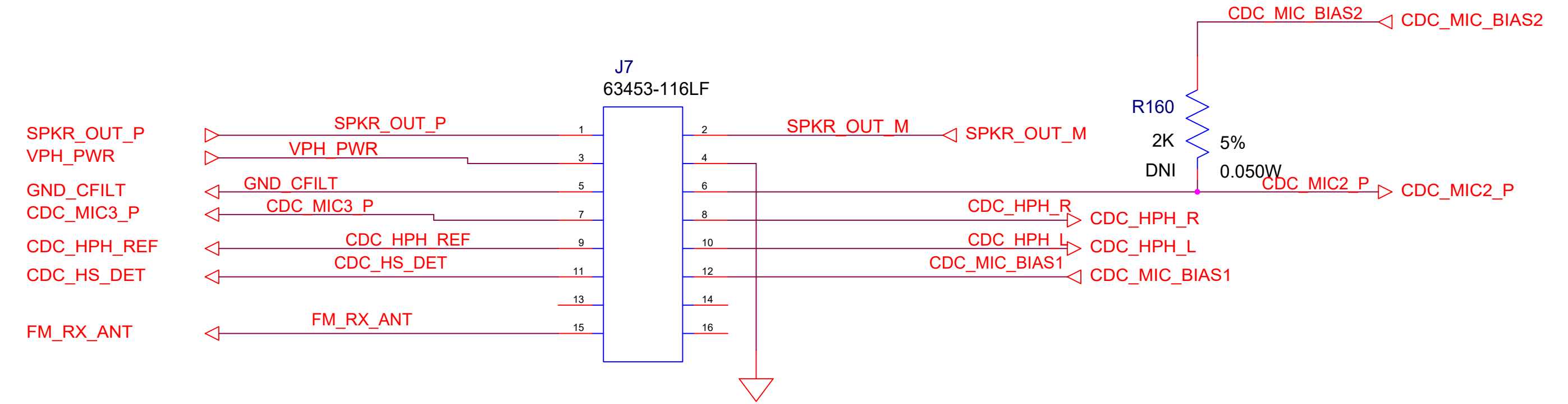

ANALOG INTERFACES

BOM CONFIG	SUPPORTED	ASSY OPTION
Hx0x	YES	INSTALL J15
Hx5x	NO	DNI J15

JTAG/UART INTERFACE TO 20-NR332 (BOTTOM) (BACKUP OPTION)

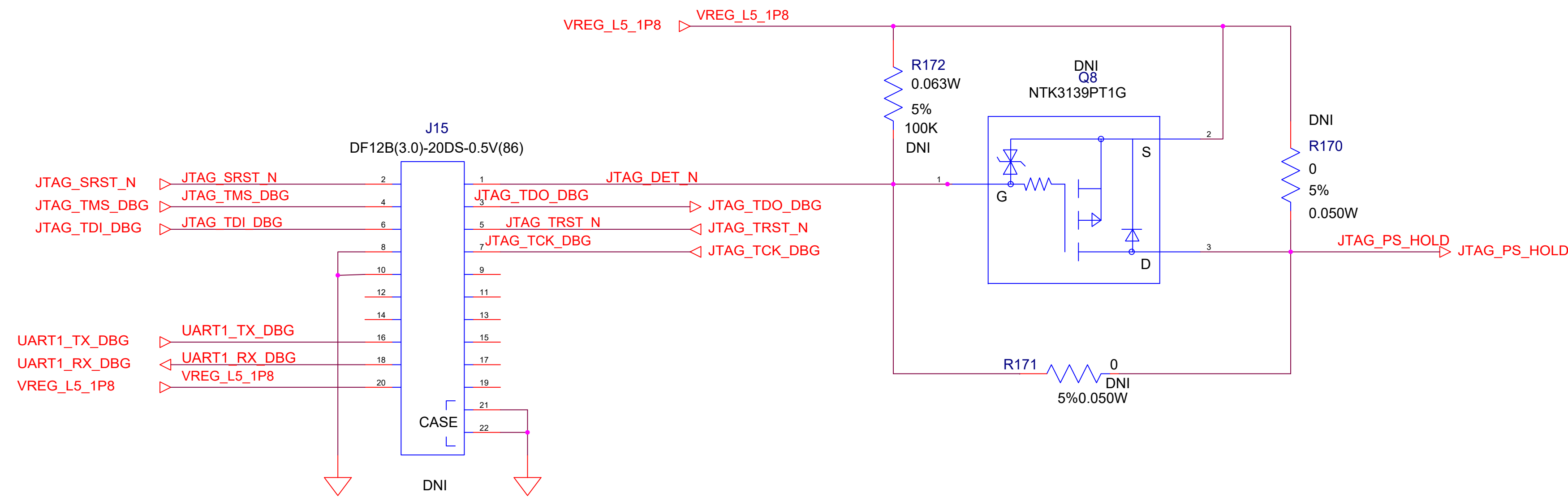

WCN3620 RF & CONTROL

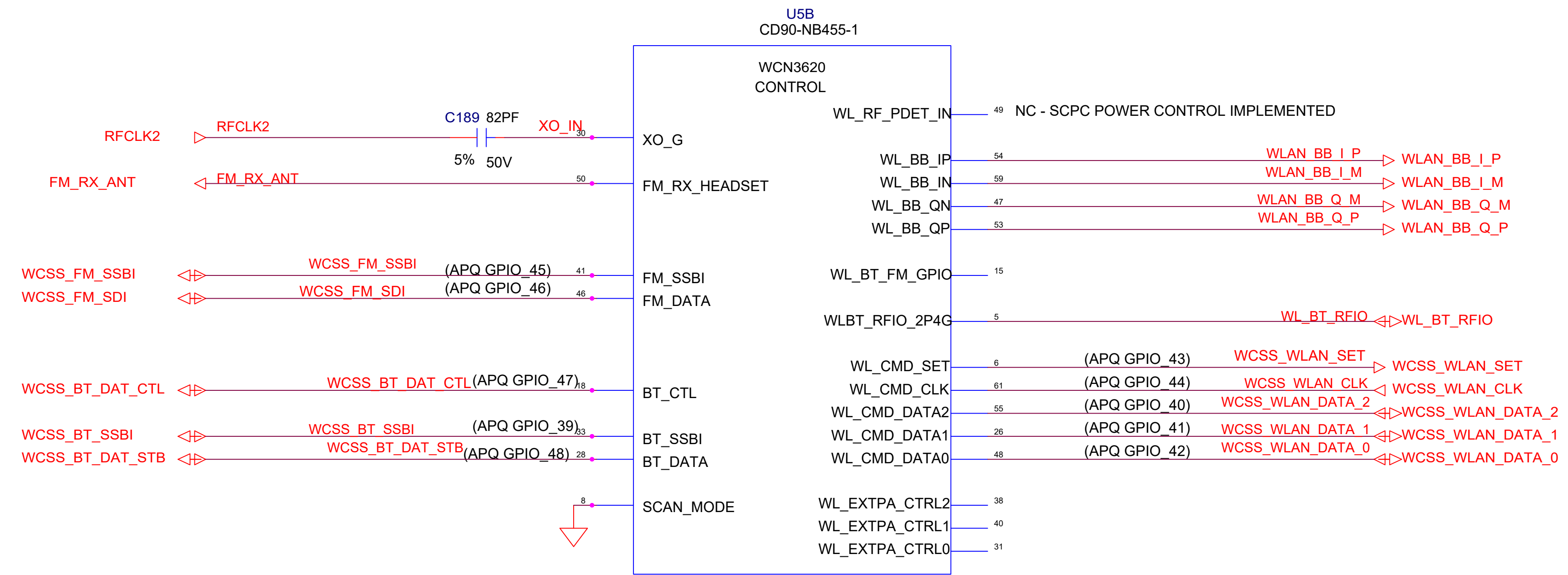

WCN & WGR Circuitry Shield

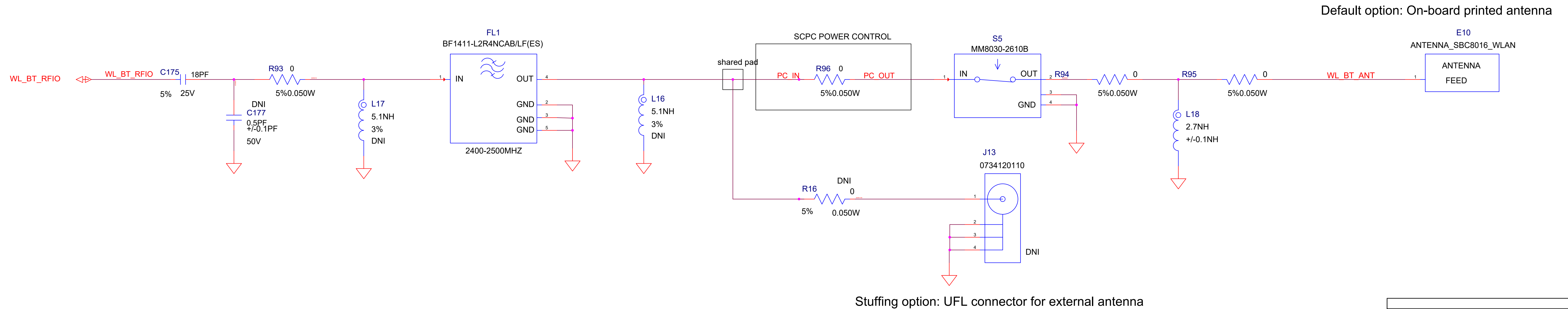
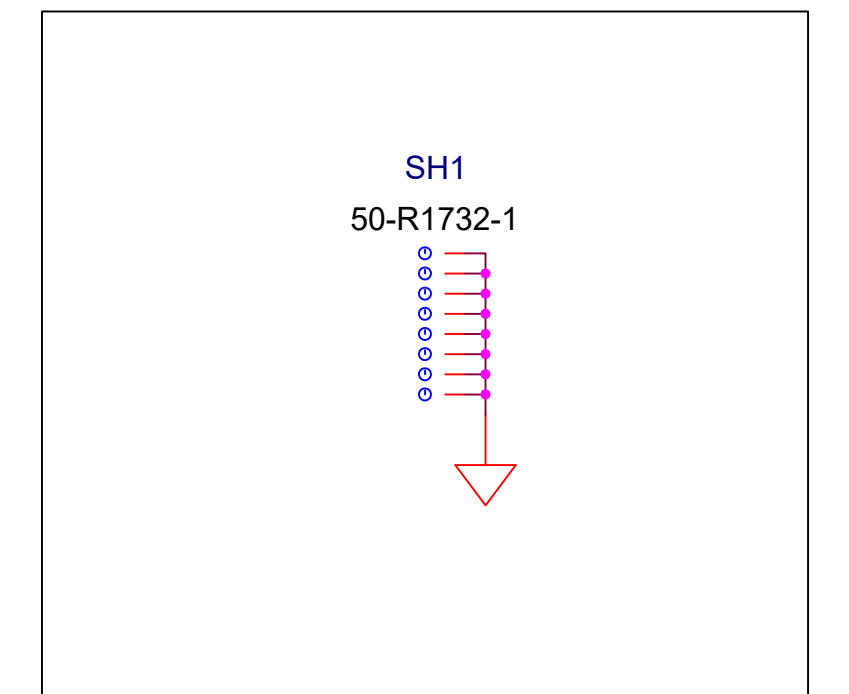

WCN3620 PWR & GND

1.3V

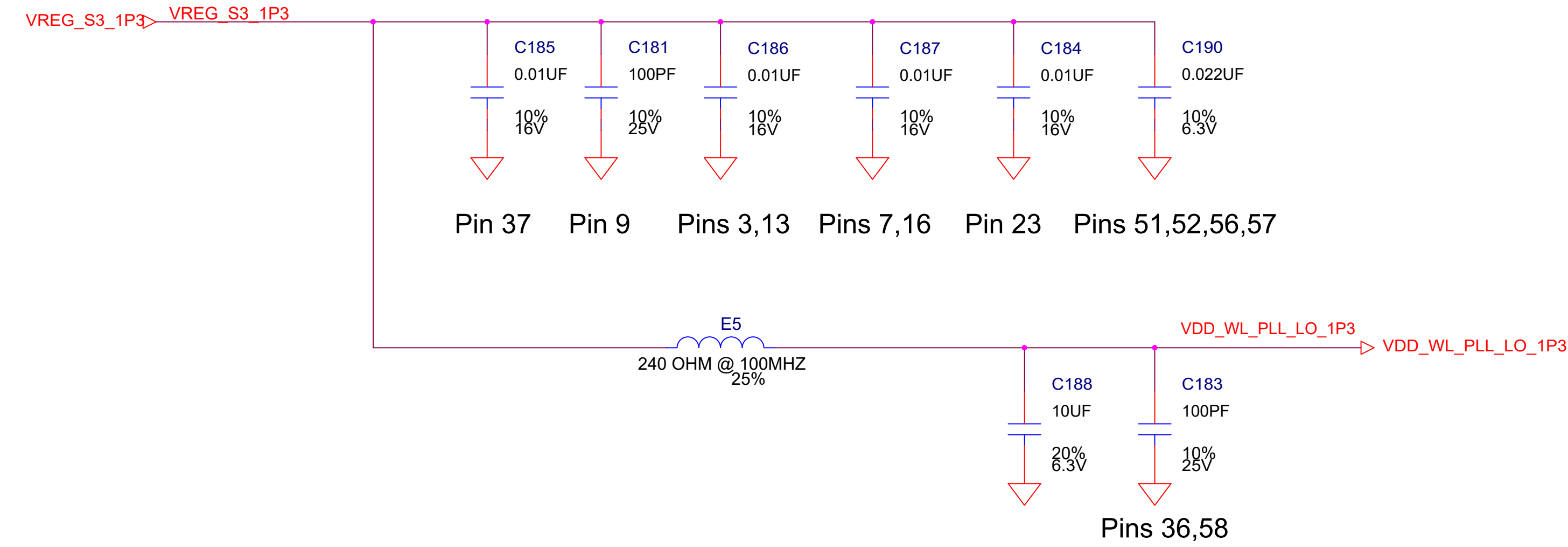

3.3V

Note: If 2.4 GHz WLAN spurs are observed around 2.6 to 2.7 GHz replace R97 with ~20 nH inductor.

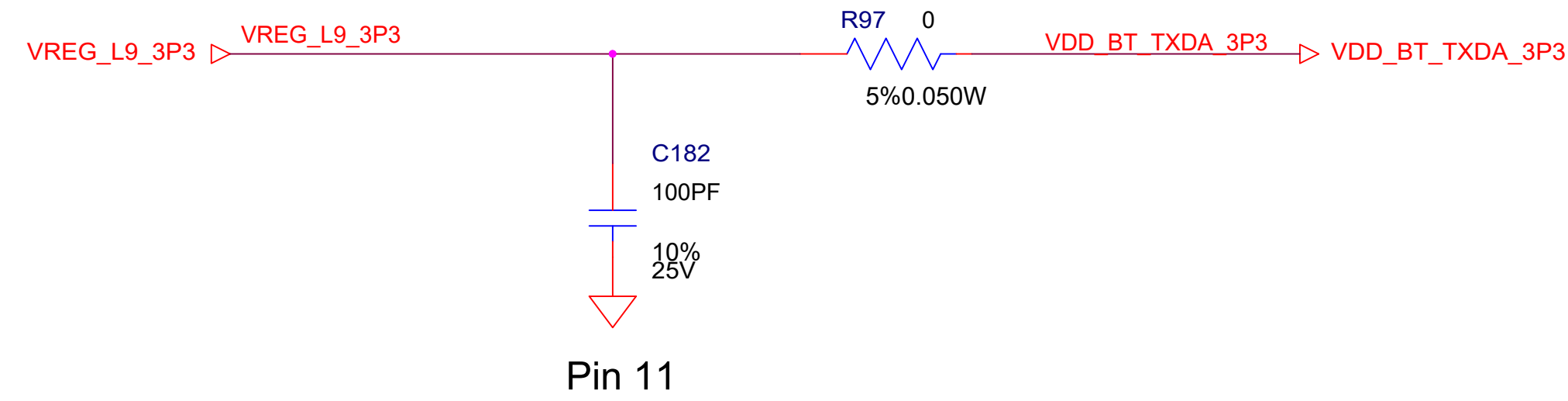

1.8V

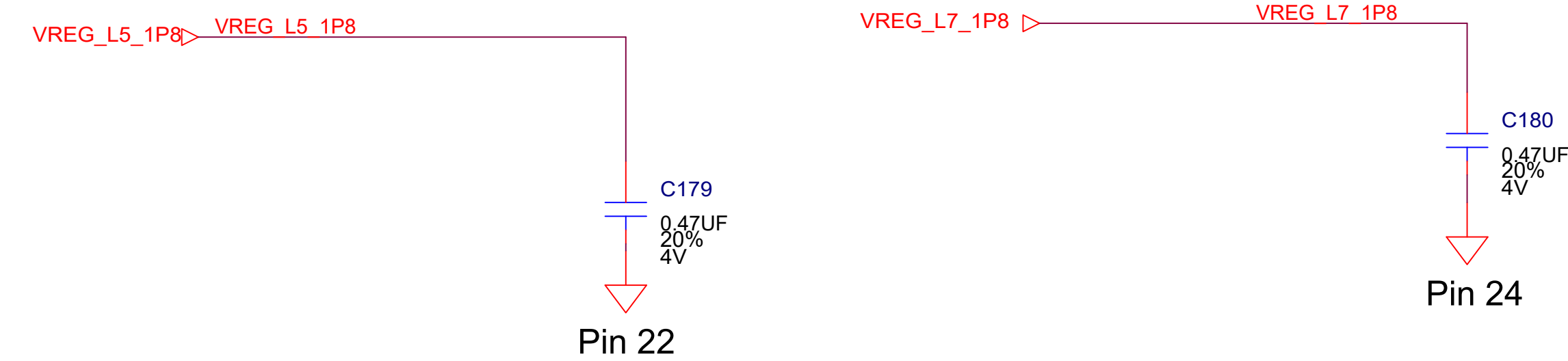

1.2V

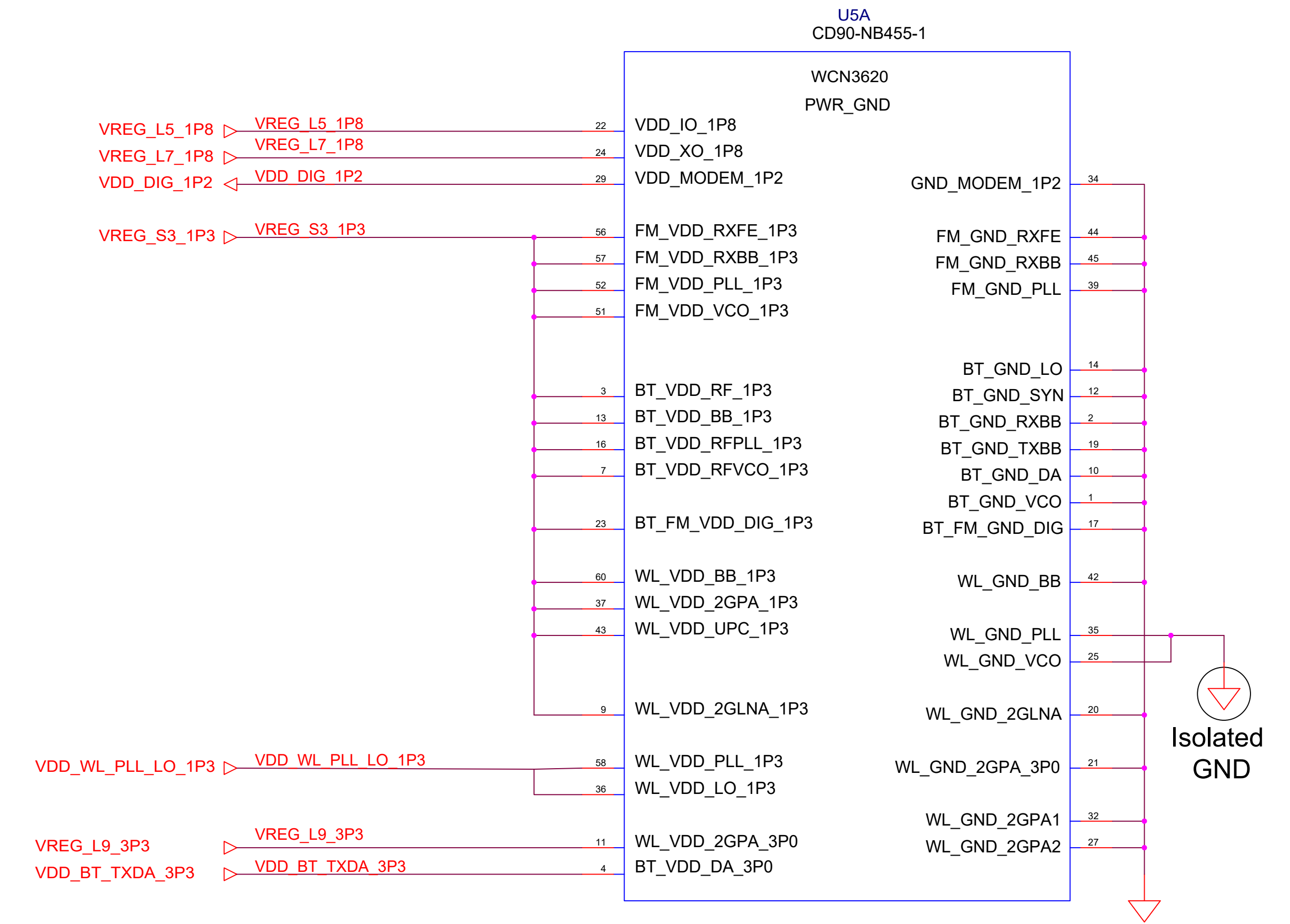
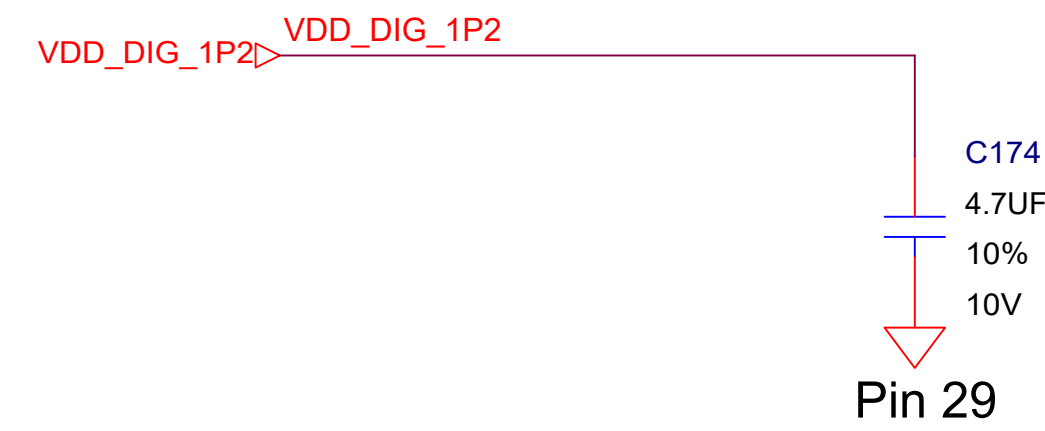

WGR7640 - GPS

