

东莞市金赞智能科技有限公司

DONGGUAN KIMCHEN INDUSTRY INTL LIMITED



东莞市金赞智能科技有限公司

产品规格书

PRODUCT SPECIFICATION

客 户:	深圳市倍力奇科技有限公司
CUSTOMER:	_____
客户料号:	_____
CUST P/N:	_____
金赞料号:	J30-000226-001
K C P/N:	_____
产品型号:	20.5*39.5*0.08*80P*11TS*20MM
D E S E :	_____
日 期:	2024.6.24
D A T E :	_____
版 本:	A.0
VERSION :	_____

(客户承认受领印) ACCEPTANCE STAMP

拟制 PREPARED BY	跟单员 MERCHANDISER	工程审核 ENGINEER CHECKED BY	批准 APPROVED BY
严慧琳			

Address: 东莞市石碣镇西沙路 2 号 Tel: 86-076986018114 Fax: 86-076986015646

Http://www.jzcoil.com

文件编号 FilNo: KC-JZ-09-008

东莞市金赞智能科技有限公司

DONGGUAN KIMCHEN INDUSTRY INTL LIMITED

规格内容 Specification	客户料号: CUST P/N	
	金赞型号: KC DESE	20.5*39.5*0.08*80P*11TS*20M M

版本变更履历 Version Change History		变更后内容 DESCRIPTION (Content Or Reason For Changed)	日期 Date	修订者 Revisor
A.0	--	新发行 (Initial Release)	2024/6/24	严慧琳

拟制 PREPARED BY	工程审核 ENGINEER CHECKED BY
严慧琳	李进

Address: 东莞市石碣镇西沙路 2 号 Tel: 86-076986018114 Fax: 86-076986015646

Http://www.jzcoil.com

文件编号 FilNo: KC-JZ-09-008

东莞市金赞智能科技有限公司

DONGGUAN KIMCHEN INDUSTRY INTL LIMITED

规格内容

客户料号:

CUST P/N

Specification

金赞型号:

KC DESE

20.5*39.5*0.08*80P*11TS*20M

M

1. 产品外形尺寸 (OVERALL DIMENSIONS OF PRODUCTS):

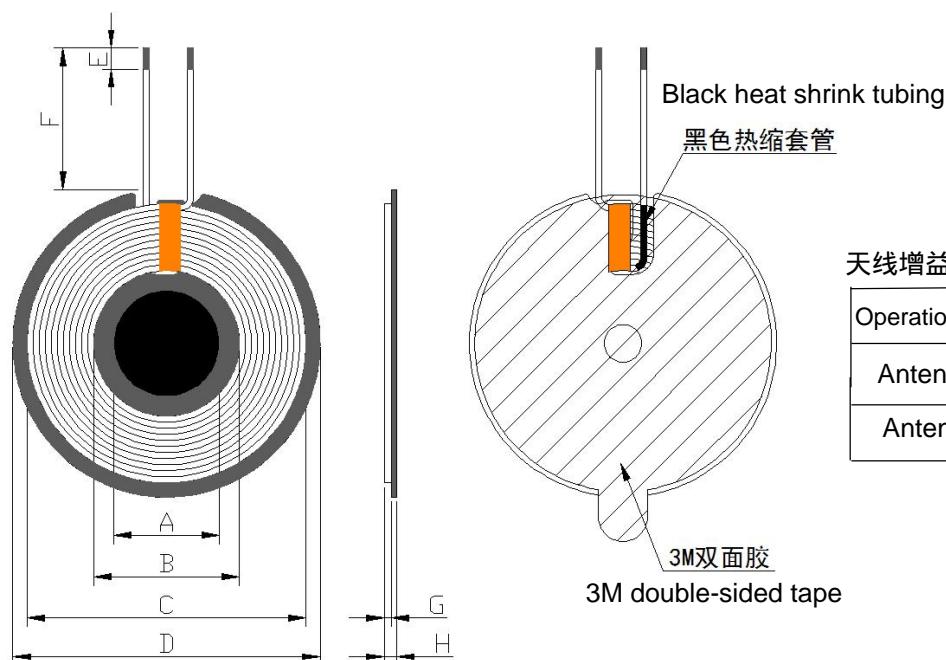

单位(Unit):毫米(mm)

A	B	C	D	E	F	G	H
15±0.5	20.5±0.5	39.5±0.5	43.5±0.5	3±1	20±1	0.95±0.05	2.15±0.2

PS:

1. (F) The length of the outer magnetic lead;

2. (H) Includes incoming wire, not release paper;

3. First, thread the thin black heat shrink sleeve, and then press the wire with a stop machine. Then, thread the wire through the sleeve to the bend and to the end.

圈数 Turns	线径 Wire Dia.	绕线方式 疏/密 Wdg. Type Spred/Close	绕线方向 Wdg. Direction	相交 是/否 Intersect Yes/Not	线圈 正/反贴 Coil Positive/Anti Paste
11TS	0.08*80P 热风绞线 (Stranded wire)	密绕 (Close)	逆时针 (Anticlockwise)	是 (Yes)	反贴 (Anti-/Paste)

所有材料要求合格 ROHS 标准 All materials are required to be ROHS compliant

拟制
PREPARED BY工程审核
ENGINEER CHECKED BY

严慧琳

李进

Address: 东莞市石碣镇西沙路 2 号 Tel: 86-076986018114 Fax: 86-076986015646

Http://www.jzcoil.com

文件编号 FilNo: KC-JZ-09-008

东莞市金赞智能科技有限公司

DONGGUAN KIMCHEN INDUSTRY INTL LIMITED

规格内容
Specification客户料号:
CUST P/N金赞型号:
KC DESE20.5*39.5*0.08*80P*11TS*20M
M

2. 电气特性 (ELECTRICAL CHARACTERISTICS):

温度 TEMPERATURE: 25±10℃, 湿度 RELATIVE HUMIDITY: 65±10%

序号 NO.	项目 ITEM	端子 TERMINAL	标准 SPECIFICATION	测试条件 TEST FREQUENCY	测试仪器 TEST EQUIPMENTS
1	IND	S-F	Coil and disc : 7.7uH±10%	100kHz/1V	LCZ METER 1062
2	DCR	S-F	Resistance: 65mΩ MAX	/	LCZ METER 1062
3	Q 值	S-F	Q value : 60MIN	100kHz/1V	LCZ METER 1062

3. 材料清单 (BILL OF MATERIALS):

序号 NO.	材料名称 Material name	品名描述 Description	物料代码 Material Code	厂商代码 Vendor code
1	Wire rod	0.08*80P hot air stranded cable	/	/
2	Large diskette	G43.5±0.5*5.3*0.8H with double groove with hole, the middle small groove 3MM	GCP-T-00298	HYT
3	minicycle	Hard magnetic circle 15*0.7H without holes or slots	GCP-T-00305	LX
4	3M double-sided tape	42*5.3*0.12H 3M9448A with hole and hand tear	SMJ-3M-00079	HWD
5	Small double-sided tape	Round ordinary double-sided tape 13*0.08H with hand tear	SMJ-T-0082	HWD
6	Gold finger tape	3mm	High temperature adhesive paper 3MM	JRM
7	glue	JS-E7202 (thickened) white glue	E7202W	HZY
8	Tin bar	Environmentally friendly lead-free solder bar	Lead-free high temperature tin strip	XC
9	Black heat shrink tubing	9MM*Φ1.5 thin	/	/

拟制
PREPARED BY工程审核
ENGINEER CHECKED BY

严慧琳

李进

Address: 东莞市石碣镇西沙路 2 号 Tel: 86-076986018114 Fax: 86-076986015646

Http://www.jzcoil.com

文件编号 FileNo: KC-JZ-09-008