



FCC 47 CFR PART 15 SUBPART C

TEST REPORT

For

Applicant: Le Shi Zhi Xin Electronic Technology (Tianjin) Limited

**Address: 201-427 2F B1 District, Anime building, No.126 Anime
Middle Road, Eco-city Tianjin, China**

Product Name: Letv GAMEPAD

Model Name: LeWGP-201

Brand Name: Letv

FCC ID: 2AFOYLEWGP-201

Report No.: MTE/DYY/S16040713

Date of Issue: Apr. 27, 2016

Issued by: Most Technology Service Co., Ltd.

**Address : No.5, Langshan 2nd Road, North District, Hi-tech Industrial Park,
Nanshan, Shenzhen, Guangdong, China**

Tel : 86-755-86026850

Fax : 86-755-26013350

The report consists 32 pages in total. It may be duplicated completely for legal use with the approval of the applicant. It should not be reproduced except in full, without the written approval of our laboratory. The client should not use it to claim product endorsement by MOST. The test results in the report only apply to the tested sample. The test report shall be invalid without all the signatures of testing engineers, reviewer and approver.

TABLE OF CONTENTS

1. VERIFICATION OF CONFORMITY.....	3
2. GENERAL INFORMATION.....	4
2.1 Product Information.....	4
2.2 Objective.....	5
2.3 Test Standards and Results.....	5
2.4 Environmental Conditions.....	5
2.5 MEASUREMENT UNCERTAINTY.....	5
3. TEST METHODOLOGY.....	6
3.1 TEST FACILITY.....	6
3.2 Test Conditions.....	6
3.3 Channel List.....	7
3.4 Description of Test Modes.....	7
3.5 Table of Parameters of Text Software Setting.....	8
3.6 FCC PART 15.205 RESTRICTED BANDS OF OPERATIONS.....	9
4. SETUP OF EQUIPMENT UNDER TEST.....	10
4.1 TEST EQUIPMENT LIST.....	10
5. 47 CFR Part 15C 15.249 Requirements.....	11
5.1 AC Power Line Conducted Emission.....	11
5.1.1 Requirement.....	11
5.1.2 Block Diagram of Test Setup.....	11
5.1.3 Test procedure.....	11
5.2.1 Requirement.....	13
5.2.2 Test Description.....	14
5.2.3 Test Description.....	15
5.2.4 Test Result.....	16
5.3 Occupied Bandwidth.....	21
5.3.1 Definition.....	24
5.3.2 Block Diagram Of Test Setup.....	24
5.4 Antenna Requirement.....	26
5.4.1 Definition.....	26
5.4.2 Evaluation Criteria.....	26
5.4.3 Evaluation Results.....	26
5.5 Restricted Frequency Bands.....	27
5.5.1 Test Requirement.....	27
5.5.3 Test Procedure:.....	27

1. VERIFICATION OF CONFORMITY

Equipment Under Test: Letv GAMEPAD
Brand Name: Letv
Model Number: LeWGP-201
Series Number: N/A
Description of Differences: N/A
FCC ID: 2AFOYLEWGP-201
Applicant: Le Shi Zhi Xin Electronic Technology (Tianjin) Limited
 201-427 2F B1 District, Anime building, No.126 Anime Middle Road, Eco-city
 Tianjin, China
Manufacturer: Le Shi Zhi Xin Electronic Technology (Tianjin) Limited
 201-427 2F B1 District, Anime building, No.126 Anime Middle Road, Eco-city
 Tianjin, China
Technical Standards: 47 CFR Part 15 Subpart C
File Number: MTE/DYY/S16040713
Date of test: Apr. 22-26, 2016
Deviation: None
Condition of Test Sample: Normal
Test Result: PASS

The above equipment was tested by MOST for compliance with the requirements set forth in FCC rules and the Technical Standards mentioned above. This said equipment in the configuration described in this report shows the maximum emission levels emanating from equipment and the level of the immunity endurance of the equipment are within the compliance requirements.

The test results of this report relate only to the tested sample identified in this report.

Tested by (+ signature): *Daisy*
 Daisy Yu Apr. 22-26, 2016

Review by (+ signature): *Henry*
 Henry Chen Apr. 26, 2016



Approved by (+ signature): *[Signature]*
 Yvette Zhou(Manager) Apr. 26, 2016

2. GENERAL INFORMATION

2.1 Product Information

Product:	Letv GAMEPAD
Trade Name:	Letv
Model Number:	LeWGP-201
Series Number:	N/A
Description of Differences:	N/A
Power Supply:	DC 5 V by USB Port DC 3.7 V by Battery
Frequency Range:	2400MHz-2483.5MHz
Modulation Type:	O-QPSK
Antenna Type:	Internal PCB Antenna
Antenna Gain:	0dBi.
Channel Number:	16
0°C ~ +40°C	0°C ~ +40°C

NOTE:

1. For a more detailed features description about the EUT, please refer to User's Manual.

2.2 Objective

Perform FCC Part 15 Subpart C tests for FCC Marking.

2.3 Test Standards and Results

Test items and the results are as bellow:

No.	Section	Description	Result	Date of Test
1	15.207	Power Line Conducted Emission	---	---
2	15.249(a) (d)	Radiated Emission	PASS	2016-04-23
3	15.249	Occupied bandwidth	PASS	2016-04-23
4	15.203	Antenna Requirement	PASS	2016-04-23
5	15.249(d)	Band Edge	PASS	2016-04-24

Note: 1. The test result judgment is decided by the limit of measurement standard
2. The information of measurement uncertainty is available upon the customer's request.

2.4 Environmental Conditions

During the measurement the environmental conditions were within the listed ranges:

- Temperature: 15-35°C
- Humidity: 30-60 %
- Atmospheric pressure: 86-106 kPa

2.5 MEASUREMENT UNCERTAINTY

The uncertainty is calculated using the methods suggested in the "Guide to the Expression of Uncertainty in Measurement" (GUM) published by ISO.

The report uncertainty of measurement $y \pm U$, where expanded uncertainty U is based on a standard uncertainty multiplied by a coverage factor of $k=2$, Providing a level of confidence of approximately 95%

- Uncertainty of Conducted Emission, $U_c = \pm 1.8\text{dB}$
- Uncertainty of Radiated Emission, $U_c = \pm 3.2\text{dB}$

3. TEST METHODOLOGY

3.1 TEST FACILITY

Test Site:	Most Technology Service Co., Ltd.
Location:	No.5, Langshan 2nd Rd., North Hi-Tech Industrial park, Nanshan, Shenzhen, Guangdong ,China
Description:	<p>There is one 3m semi-anechoic an area test sites and two line conducted labs for final test. The Open Area Test Sites and the Line Conducted labs are constructed and calibrated to meet the FCC requirements in documents ANSI C63.10:2013 and CISPR 16 requirements.</p> <p>The FCC Registration Number is 490827.</p> <p>The IC Registration Number is 7103A-1.</p> <p>The CNAS Registration Number is CNAS L3573.</p>
Site Filing:	The site description is on file with the Federal Communications Commission, 7435 Oakland Mills Road, Columbia, MD 21046.
Instrument Tolerance:	All measuring equipment is in accord with ANSI C63.10:2013 and CISPR 16 requirements that meet industry regulatory agency and accreditation agency requirement.
Ground Plane:	Two conductive reference ground planes were used during the Line Conducted Emission, one in vertical and the other in horizontal. The dimensions of these ground planes are as below. The vertical ground plane was placed distancing 40 cm to the rear of the wooden test table on where the EUT and the support equipment were placed during test. The horizontal ground plane projected 50 cm beyond the footprint of the EUT system and distanced 80 cm to the wooden test table. For Radiated Emission Test, one horizontal conductive ground plane extended at least 1m beyond the periphery of the EUT and the largest measuring antenna, and covered the entire area between the EUT and the antenna.

3.2 Test Conditions

The EUT has been tested under normal operating (TX) .

The field strength of radiation emission was measured in the following position: EUT lie-down position (X axis).

The following data show X axis setup.

Based on client request, all normal using modes of the normal function were tested but only the worst test data of the worst mode is reported by this report.

3.3 Channel List

Channel List for O-QPSK Mode					
Channel	Frequency (MHz)	Channel	Frequency (MHz)	Channel	Frequency (MHz)
11	2405MHz	17	2435MHz	23	2465MHz
12	2410MHz	18	2440MHz	24	2470MHz
13	2415MHz	19	2445MHz	25	2475MHz
14	2420MHz	20	2450MHz	26	2480MHz
15	2425MHz	21	2455MHz		
16	2430MHz	22	2460MHz		

3.4 Description of Test Modes

To investigate the maximum EMI emission characteristics generated from EUT, the test system was pre-scanning tested based on the consideration of following EUT operation mode or test configuration mode which possibly have effect on EMI emission level. Each of these EUT operation mode(s) or test configuration mode(s) mentioned above was evaluated respectively.

Pre-test Mode	Description
Mode 1	O-QPSK CH11/CH18/CH26

Note:

The measurements are performed at the highest, middle, lowest available channels.

3.5 Table of Parameters of Text Software Setting

During testing channel & power controlling software provided by the customer was used to control the operating channel as well as the output power level, the RF output power selection is for the setting of RF output power expected by the customer and is going to be fixed on the firmware of the final end product power parameters of Zigbee.

Test software Version	Test channels		
O-QPSK Mode	2405MHz	2440MHz	2480MHz

Radiated Emissions

The EUT is placed on a turn table, which is 1.5 m above ground plane. The turntable shall rotate 360 degrees to determine the position of maximum emission level. EUT is set 3m away from the receiving antenna, which varied from 1m to 4m to find out the highest emission. And also, each emission was to be maximized by changing the polarization of receiving antenna both horizontal and vertical. In order to find out the maximum emissions, exploratory radiated emission measurements were made according to the requirements in Section 6.5 of ANSI C63.10:2013.

Conducted Emissions

The EUT is placed on the turntable, which is 0.8 m above ground plane. According to the requirements in Section 6.2 of ANSI C63.10:2013, Conducted emissions from the EUT measured in the frequency range between 0.15 MHz and 30MHz using CISPR Quasi-peak and average detector modes.

3.6 FCC PART 15.205 RESTRICTED BANDS OF OPERATIONS

- (a) Except as shown in paragraph (d) of this section, only spurious emissions are permitted in any of the frequency bands listed below:

MHz	MHz	MHz	GHz
0.090 - 0.110	16.42 - 16.423	399.9 - 410	4.5 - 5.15
¹ 0.495 - 0.505	16.69475 - 16.69525	608 - 614	5.35 - 5.46
2.1735 - 2.1905	16.80425 - 16.80475	960 - 1240	7.25 - 7.75
4.125 - 4.128	25.5 - 25.67	1300 - 1427	8.025 - 8.5
4.17725 - 4.17775	37.5 - 38.25	1435 - 1626.5	9.0 - 9.2
4.20725 - 4.20775	73 - 74.6	1645.5 - 1646.5	9.3 - 9.5
6.215 - 6.218	74.8 - 75.2	1660 - 1710	10.6 - 12.7
6.26775 - 6.26825	108 - 121.94	1718.8 - 1722.2	13.25 - 13.4
6.31175 - 6.31225	123 - 138	2200 - 2300	14.47 - 14.5
8.291 - 8.294	149.9 - 150.05	2310 - 2390	15.35 - 16.2
8.362 - 8.366	156.52475 - 156.52525	2483.5 - 2500	17.7 - 21.4
8.37625 - 8.38675	156.7 - 156.9	2655 - 2900	22.01 - 23.12
8.41425 - 8.41475	162.0125 - 167.17	3260 - 3267	23.6 - 24.0
12.29 - 12.293	167.72 - 173.2	3332 - 3339	31.2 - 31.8
12.51975 - 12.52025	240 - 285	3345.8 - 3358	36.43 - 36.5
12.57675 - 12.57725	322 - 335.4	3600 - 4400	(²)
13.36 - 13.41			

¹ Until February 1, 1999, this restricted band shall be 0.490-0.510 MHz.

² Above 38.6

- (b) Except as provided in paragraphs (d) and (e), the field strength of emissions appearing within these frequency bands shall not exceed the limits shown in Section 15.209. At frequencies equal to or less than 1000 MHz, compliance with the limits in Section 15.209 shall be demonstrated using measurement instrumentation employing a CISPR quasi-peak detector. Above 1000 MHz, compliance with the emission limits in Section 15.209 shall be demonstrated based on the average value of the measured emissions. The provisions in Section 15.35 apply to these measurements.

4. SETUP OF EQUIPMENT UNDER TEST

4.1 TEST EQUIPMENT LIST

Instrumentation: The following list contains equipment used at Most for testing. The equipment conforms to the CISPR 16-1 / ANSI C63.2 Specifications for Electromagnetic Interference and Field Strength Instrumentation from 10 kHz to 1.0 GHz or above.

No.	Equipment	Manufacturer	Model No.	S/N	Calibration date	Calibration Interval
1	Test Receiver	Rohde & Schwarz	ESCI	100492	2016/03/10	1 Year
2	Spectrum Analyzer	Agilent	E7405A	US44210471	2016/03/14	1 Year
3	L.I.S.N.	Rohde & Schwarz	ENV216	100093	2016/03/10	1 Year
4	Coaxial Switch	Anritsu Corp	MP59B	6200283933	2016/03/07	1 Year
5	Terminator	Hubersuhner	50Ω	No.1	2016/03/07	1 Year
6	RF Cable	SchwarzBeck	N/A	No.1	2016/03/07	1 Year
7	Test Receiver	Rohde & Schwarz	ESPI	101202	2016/03/10	1 Year
8	Bilog Antenna	Sunol	JB3	A121206	2016/03/14	1 Year
9	Horn Antenna	SCHWARZBECK	BBHA9120D	756	2016/03/14	1 Year
10	Horn Antenna	Penn Engineering	9034	8376	2016/03/14	1 Year
11	Cable	Resenberger	N/A	NO.1	2016/03/07	1 Year
12	Cable	SchwarzBeck	N/A	NO.2	2016/03/07	1 Year
13	Cable	SchwarzBeck	N/A	NO.3	2016/03/07	1 Year
14	Single Phase Power Line Filter	DuoJi	FNF 202B30	N/A	2016/03/07	1 Year
15	Test Receiver	Rohde & Schwarz	ESCI	100492	2016/03/10	1 Year
16	Loop antenna	ARA	PLA-1030/B	1039	2016/03/14	1 Year

NOTE: Equipments listed above have been calibrated and are in the period of validation.

5. 47 CFR Part 15C 15.249 Requirements

5.1 AC Power Line Conducted Emission

5.1.1 Requirement

A radio apparatus that is designed to be connected to the public utility (AC) power line shall ensure that the radio frequency voltage, which is conducted back onto the AC power line on any frequency or frequencies within the and 150 kHz-30 MHz, shall not exceed the limits in the following table:

Frequency	Maximum RF Line Voltage	
	Q.P.(dBuV)	Average(dBuV)
150kHz-500kHz	66-56	56-46
500kHz-5MHz	56	46
5MHz-30MHz	60	50

****Note:** 1. the lower limit shall apply at the band edges.

2. The limit decreases linearly with the logarithm of the frequency in the range 0.15 MHz to 0.50 MHz

5.1.2 Block Diagram of Test Setup

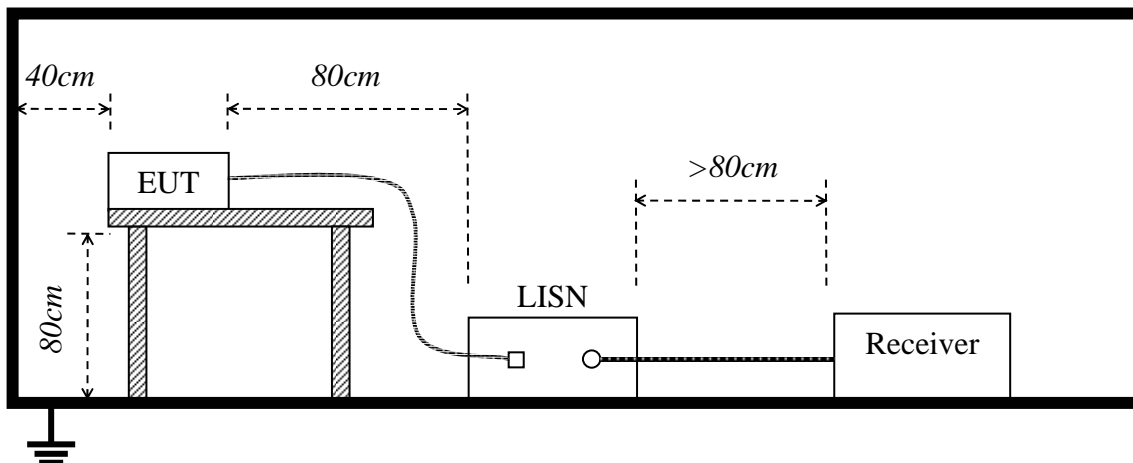

5.1.3 Test procedure

1. The E.U.T and simulators are connected to the main power through a line impedance stabilization network (L.I.S.N.). This provides a 50ohm/50uH coupling impedance for the measuring equipment.
2. Exploratory measurements were made to identify the frequency of the emission that has the highest amplitude relative to the limit;
3. The peripheral devices are also connected to the main power through a LISN that provides a 50ohm/50uH coupling impedance with 50ohm termination. (Please refer to the block diagram of the test setup and photographs).
4. Both sides of A.C. line are checked for maximum conducted interference. In order to find the maximum emission, the relative positions of equipment and all of the interface cables must be changed according to ANSI C63.4: 2009 on conducted measurement.
5. The bandwidth of test receiver (ESCI) set at 9 KHz.

6. All data was recorded in the Quasi-peak and average detection mode.

5.1.4 Test Result

Not applicable to battery-operated device.

5.2 Radiated Emission Test

5.2.1 Requirement

According to FCC section 15.249(a):

Except as provided in paragraph (a) of this section, the field strength of emissions from intentional radiators operated within these frequency bands shall comply with the following:

Fundamental Frequency (MHz)	Field Strength of Fundamental (mV/m)	Field Strength of Harmonics (μ V/m)
902-928	50	500
2400-2483.5	50	500
5725-5875	50	500
24000-24250	250	2500

According to FCC section 15.249(d), Emissions radiated outside of the specified frequency bands, except for harmonics, shall be attenuated by at least 50 dB below the level of the fundamental or to the general radiated emission limits in §15.209, whichever is the lesser attenuation.

According to FCC section 15.209 (a), except as provided elsewhere in this subpart, the emissions from an intentional radiator shall not exceed the field strength levels specified in the following table:

Frequency (MHz)	Field Strength (μ V/m)	Measurement Distance (m)
1.705 – 30.0	30	30
30 – 88	100	3
88 – 216	150	3
216 – 960	200	3
Above 960	500	3

Remark: Except as provided in paragraph (g), fundamental emissions from intentional radiators operating under this Section shall not be located in the frequency bands 54- 72 MHz, 76-88 MHz, 174-216 MHz or 470-806 MHz. However, operation within these frequency bands is permitted under other sections of this Part, e.g., Sections 15.231 and 15.241.

In the above emission table, the tighter limit applies at the band edges.

Frequency (MHz)	Field Strength (μ V/m)	Measurement Distance (m)
30 – 88	100	3
88 – 216	150	3
216 – 960	200	3
Above 960	500	3

5.2.2 Test Description

Test Setup:

From 9KHz to 30MHz:

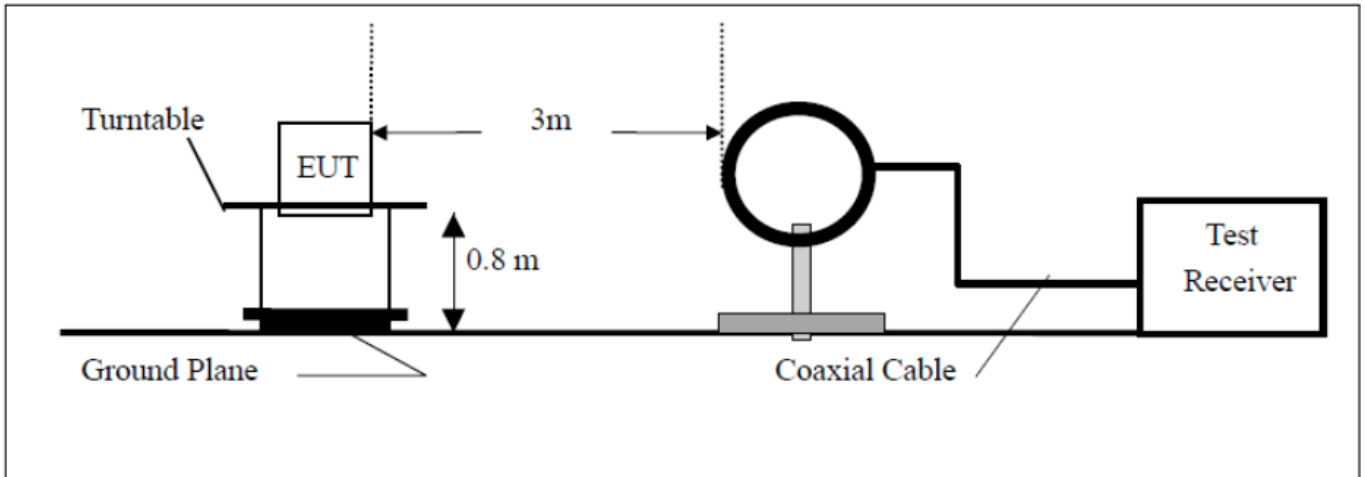

From 30MHz to 1GHz:

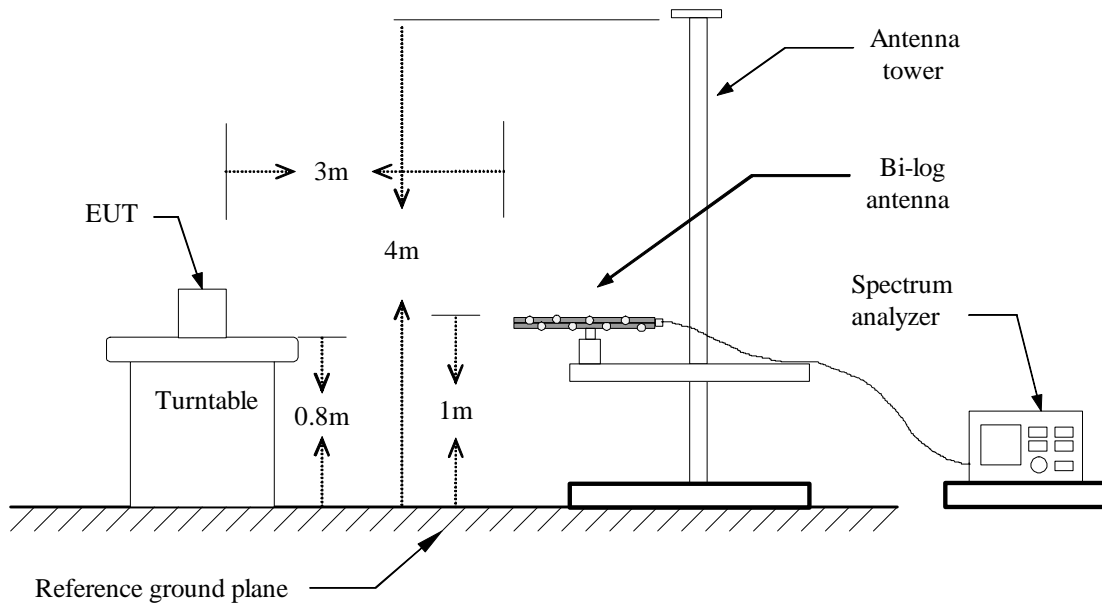

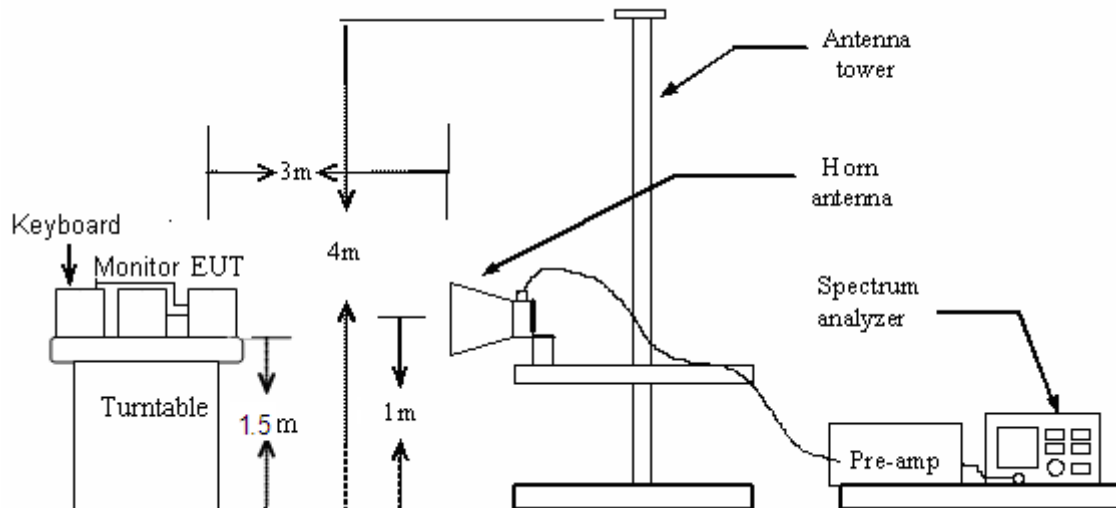
Above 1GHz:**5.2.3 Test Description**

1. For frequencies above 1GHz, the frequencies of maximum emission was recorded by manually positioning the antenna close to the EUT and by moving the antenna over all sides of the EUT while observing a spectral display.
2. The EUT was placed on the top of a rotating table 1.5 meters above the ground at a 3 meter chamber. The table was rotated 360 degrees to determine the position of the highest radiation.
3. The EUT was set 3 meters away from the interference-receiving antenna, which was mounted on the top of a variable-height antenna tower.
4. The antenna height is varied from one meter to four meters above the ground to determine the maximum value of the field strength. Both horizontal and vertical polarizations of the antenna are set to make the measurement.
5. For each suspected emission, the EUT was arranged to its worst case and then the antenna was tuned to heights from 1 meter to 4 meters and the rotate table was turned from 0 degrees to 360 degrees to find the maximum reading.
6. For frequencies above 1GHz, horn antenna mouth should face to the EUT all the time when rise or fall.
7. Set the spectrum analyzer in the following setting as:

Below 1GHz: PEAK: RBW=100 kHz / VBW=300 kHz / Sweep=AUTO QP: RBW=120 kHz / Sweep=AUTO

Above 1GHz: (a) PEAK: RBW=VBW=1MHz / Sweep=AUTO

(b) AVERAGE: RBW=1MHz / VBW=10Hz / Sweep=AUTO

The test-receiver system was set to Peak Detect Function and Specified Bandwidth with Maximum Hold Mode.

8. If the emission level of the EUT in peak mode was 10dB lower than the limit specified, then testing could be stopped and the peak values of the EUT would be reported. Otherwise the emissions that did not have 10dB margin would be re-tested one by one using peak, quasi-peak or average method as specified and then reported in a data sheet.

5.2.4 Test Result

From 9 KHz to 30MHz:

Freq. (MHz)	Ant. Pol H/V	Peak Reading (dBuV)	AV Reading (dBuV)	Ant. / CL CF (dB)	Actual Fs		Peak Limit (dBuV/m)	AV Limit (dBuV/m)	AV Margin (dB)
					Peak (dBuV/m)	AV (dBuV/m)			
N/A	H								
N/A	V								

Remark: After pre-testing, the level of testing data was too low, no data recorded.

From 30MHz to 25GHz:

The following test mode(s) were scanned during the preliminary test:

Preliminary Radiated Emission Test				
Frequency Range Investigated		30MHz TO 25 GHz		
Mode of operation	Date	Report No.	Data#	Worst Mode
O-QPSK	2016-04-27	MTE/DYY/S16040713	LeWGP-201	<input checked="" type="checkbox"/>

Below 1 GHz

EUT:	Letv GAMEPAD	M/N:	LeWGP-201
Mode:	Running+ Charging	Polarization	Horizontal
Test by:	John	Power:	DC 5V by USB Port
Temperature: / Humidity	24.4°C / 51.6%	Test date:	2016-04-23

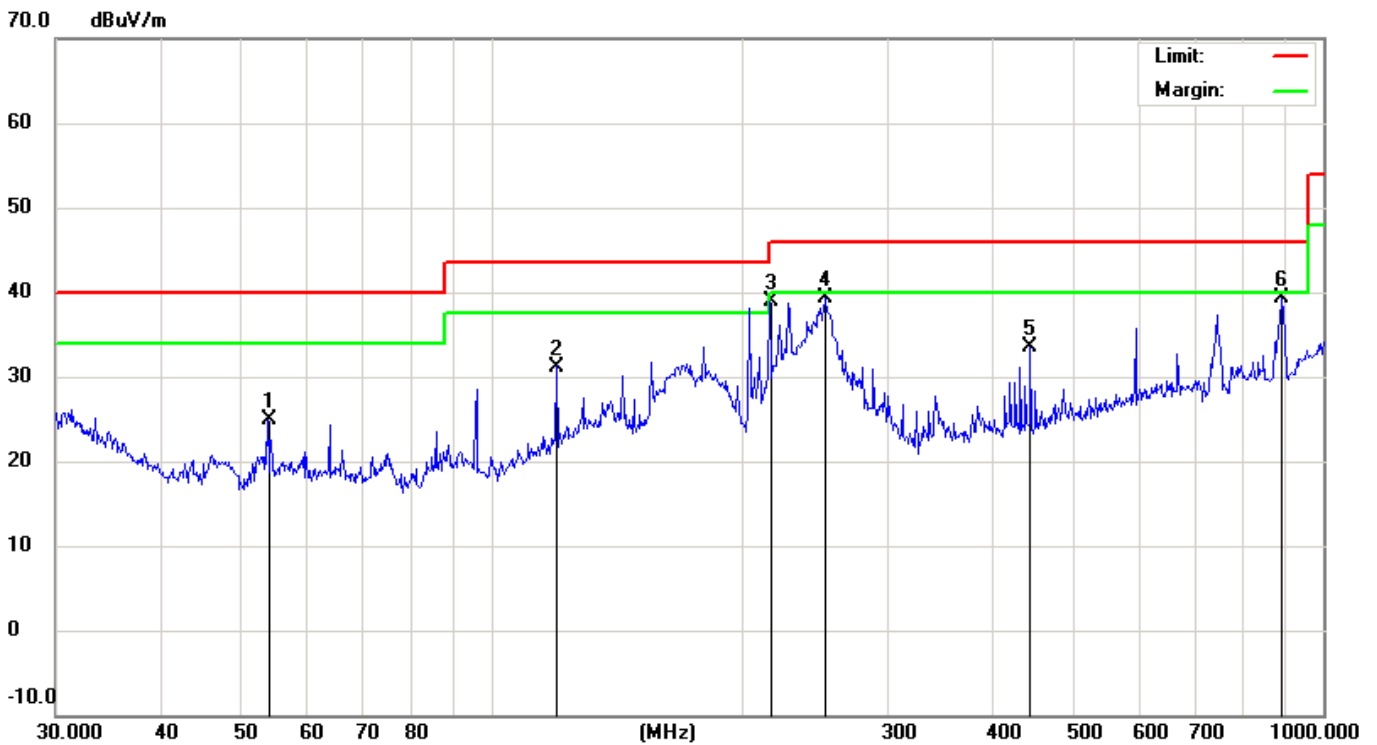

No.	Mk.	Freq. MHz	Reading Level dBuV	Correct Factor dB	Measure- ment dBuV/m	Limit dBuV/m	Over dB	Detector	Antenna Height cm	Table Degree	Comment
1		53.8818	14.42	10.50	24.92	40.00	-15.08	QP			
2		119.8556	13.72	17.48	31.20	43.50	-12.30	QP			
3		216.0240	22.79	16.14	38.93	46.00	-7.07	QP			
4	*	252.0627	21.92	17.44	39.36	46.00	-6.64	QP			
5		444.8514	13.23	20.20	33.43	46.00	-12.57	QP			
6		890.7277	11.95	27.31	39.26	46.00	-6.74	QP			

*:Maximum data x:Over limit !:over margin

EUT:	Letv GAMEPAD	M/N:	LeWGP-201
Mode:	Running+ Charging	Polarization	Vertical
Test by:	John	Power:	DC 5V by USB Port
Temperature: / Humidity	24.4°C / 51.6%	Test date:	2016-04-23

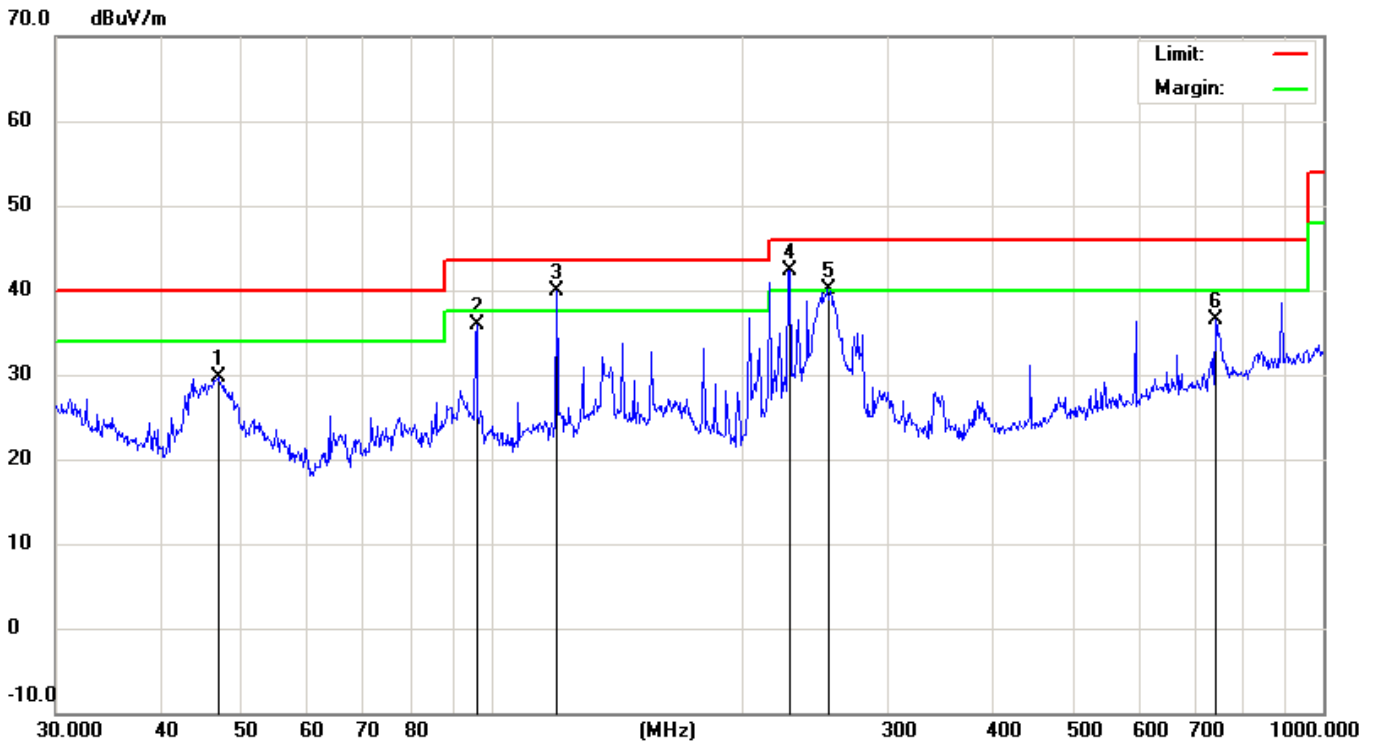

No.	Mk.	Freq. MHz	Reading Level dBuV	Correct Factor dB	Measure- ment dBuV/m	Limit dBuV/m	Over dB	Antenna Height cm	Table Degree	Detector	Comment
1		47.1598	17.78	11.92	29.70	40.00	-10.30			QP	
2		96.0986	23.34	12.50	35.84	43.50	-7.66			QP	
3	*	119.8556	22.40	17.48	39.88	43.50	-3.62			QP	
4	!	228.4904	25.79	16.47	42.26	46.00	-3.74			QP	
5	!	253.8367	22.68	17.48	40.16	46.00	-5.84			QP	
6		742.2587	10.93	25.57	36.50	46.00	-9.50			QP	

*:Maximum data x:Over limit !:over margin

About 1GHz:**Fundamental frequency measurement :**

Freq. (MHz)	Peak Reading (dBuV)	AV Reading (dBuV)	Ant. / CL CF (dB)	Actual Fs		Peak Limit (dBuV/m)	AV Limit (dBuV/m)	Peak Margin (dB)	AV Margin (dB)
				Peak (dBuV/m)	AV (dBuV/m)				
Horizontal									
2405.00	99.61	80.50	-8.42	87.19	72.08	114.00	94.00	-26.81	-21.92
2440.00	99.24	81.11	-8.35	90.89	72.76	114.00	94.00	-23.11	-21.24
2480.00	98.76	80.69	-8.30	90.46	72.39	114.00	94.00	-23.54	-21.61
Vertical									
2405.00	95.95	79.93	-8.42	87.53	71.51	114.00	94.00	-26.47	-22.49
2440.00	93.86	86.25	-8.35	85.44	77.90	114.00	94.00	-28.56	-16.10
2480.00	93.58	85.83	-8.30	85.28	77.53	114.00	94.00	-28.65	-16.33

Note:

The O-QPSK Low channel modulation type was the worst case condition, The worse test data was shown on the summary data page.

EUT:	Letv GAMEPAD	M/N:	LeWGP-201
Mode:	GFSK-CH0	Polarization	Horizontal
Test by:	John	Power:	DC 5V by USB Port
Temperature: / Humidity	24.7°C / 51.9%	Test date:	2016-04-23

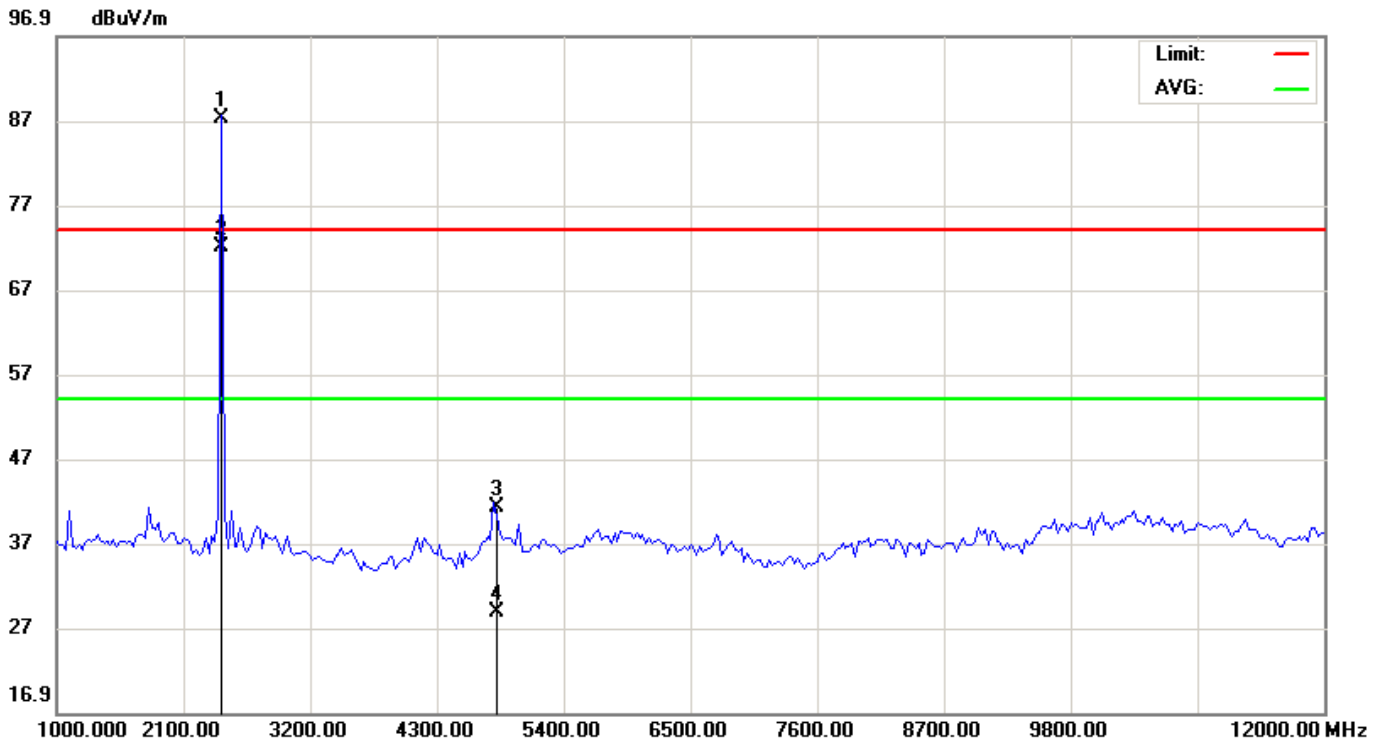

No.	Mk.	Freq. MHz	Reading Level dBuV	Correct Factor dB	Measure- ment dBuV/m	Limit dBuV/m	Over dB	Detector	Antenna Height cm	Table Degree degree	Comment
1	X	2405.000	95.61	-8.42	87.19	74.00	13.19	peak			
2	*	2405.000	80.50	-8.42	72.08	54.00	18.08	AVG			
3		4810.000	47.22	-6.08	41.14	74.00	-32.86	peak			
4		4810.000	34.90	-6.08	28.82	54.00	-25.18	AVG			

*:Maximum data x:Over limit !:over margin

EUT:	Letv GAMEPAD	M/N:	LeWGP-201
Mode:	GFSK-CH0	Polarization	Horizontal
Test by:	John	Power:	DC 5V by USB Port
Temperature: / Humidity	24.7°C / 51.9%	Test date:	2016-04-23

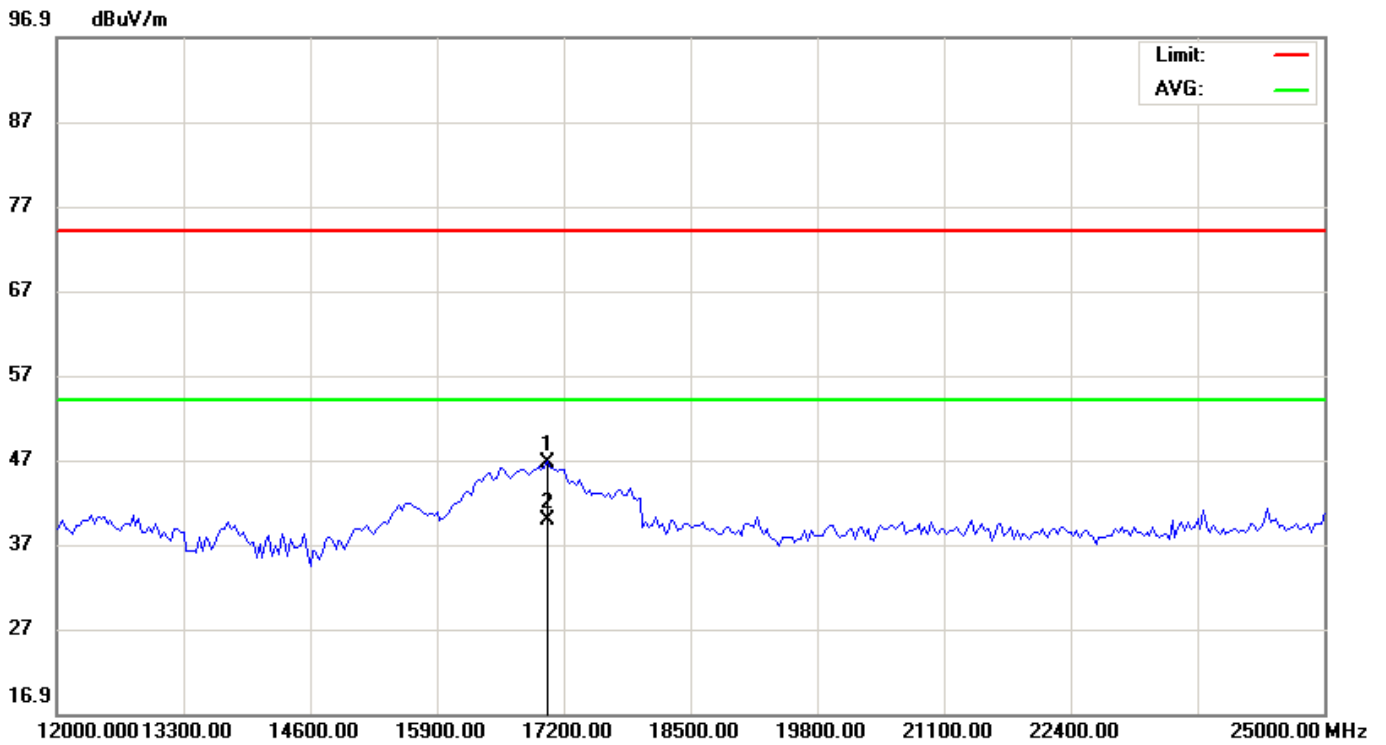

No.	Mk.	Freq. MHz	Reading Level dBuV	Correct Factor dB	Measure- ment dBuV/m	Limit dBuV/m	Over dB	Detector	Antenna Height cm	Table Degree	Comment
1		17037.50	39.89	6.73	46.62	74.00	-27.38	peak			
2	*	17037.50	33.01	6.73	39.74	54.00	-14.26	AVG			

*:Maximum data x:Over limit !:over margin

EUT:	Letv GAMEPAD	M/N:	LeWGP-201
Mode:	GFSK-CH0	Polarization	Vertiacal
Test by:	John	Power:	DC 5V by USB Port
Temperature: / Humidity	24.7°C / 51.9%	Test date:	2016-04-23

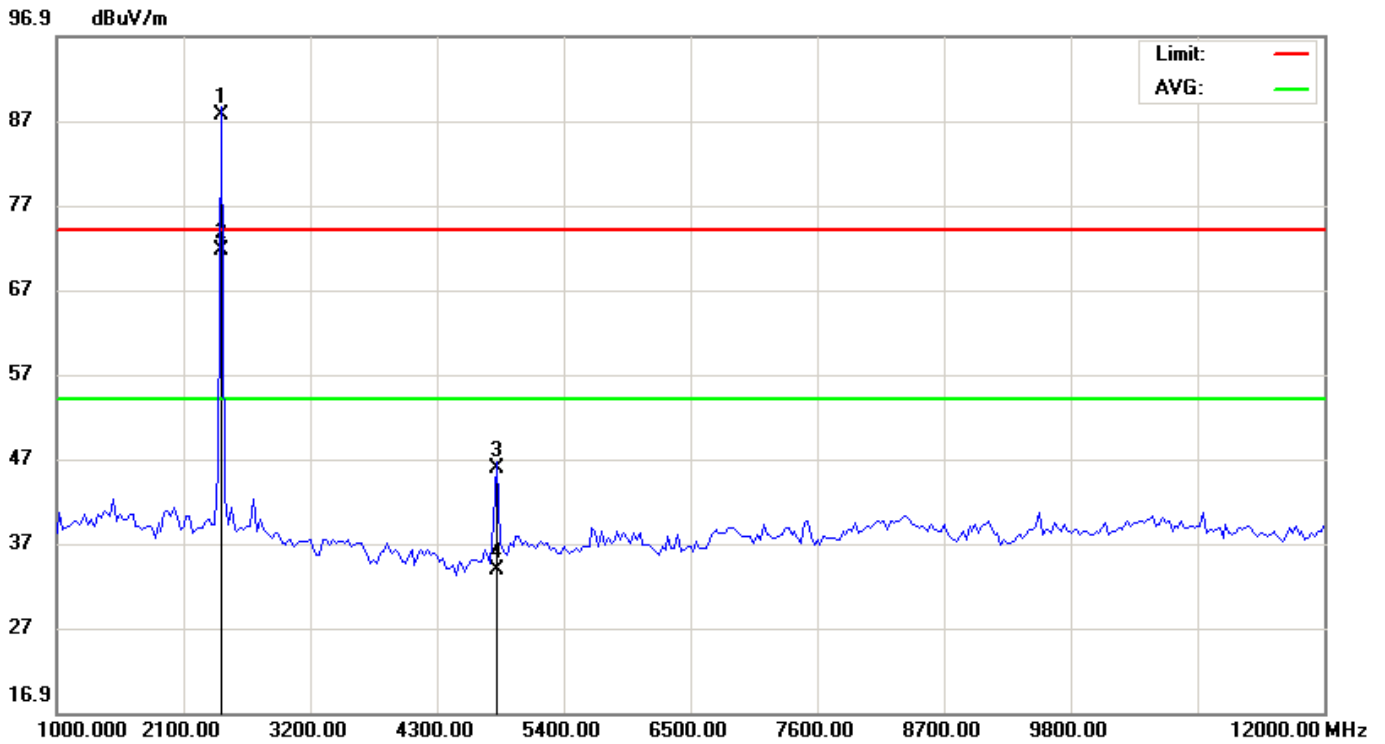

No.	Mk.	Freq. MHz	Reading Level dBuV	Correct Factor dB	Measure- ment dBuV/m	Limit dBuV/m	Over dB	Detector	Antenna Height cm	Table Degree	Comment
1	X	2405.000	95.95	-8.42	87.53	74.00	13.53	peak			
2	*	2405.000	79.93	-8.42	71.51	54.00	17.51	AVG			
3		4810.000	51.94	-6.08	45.86	74.00	-28.14	peak			
4		4810.000	39.80	-6.08	33.72	54.00	-20.28	AVG			

*:Maximum data x:Over limit !:over margin

EUT:	Letv GAMEPAD	M/N:	LeWGP-201
Mode:	GFSK-CH0	Polarization	Vertiacal
Test by:	John	Power:	DC 5V by USB Port
Temperature: / Humidity	24.7°C / 51.9%	Test date:	2016-04-23

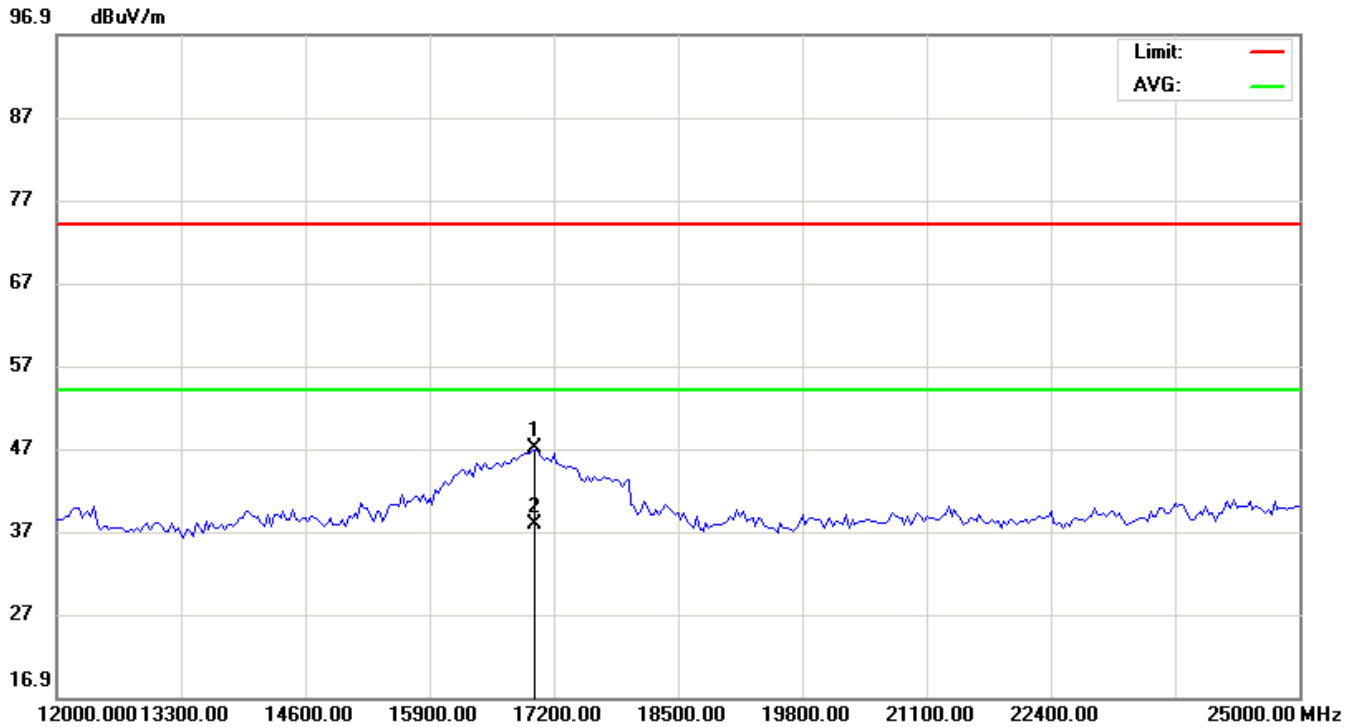

No.	Mk.	Freq. MHz	Reading Level dBuV	Correct Factor dB	Measure- ment dBuV/m	Limit dBuV/m	Over dB	Detector	Antenna Height cm	Table Degree degree	Comment
1		17005.00	40.01	6.90	46.91	74.00	-27.09	peak			
2	*	17005.00	30.98	6.90	37.88	54.00	-16.12	AVG			

*:Maximum data x:Over limit !:over margin

5.3 Occupied Bandwidth

5.3.1 Definition

Intentional radiators operating under the alternative provisions to the general emission limits, as Contained in §§15.217 through 15.257 and in sub-part E of this part, must be designed to ensure that the 20 dB Bandwidth of the emission, or whatever bandwidth may otherwise be specified in the specific Rule section under which the equipment operates, is contained within the frequency band designated in the rule section under which the equipment is operated.

5.3.2 Block Diagram Of Test Setup

The EUT is powered by the Battery, is coupled to the Spectrum Analyzer (SA) through the Attenuator/DC Block. The path loss as the factor is calibrated to correct the reading. During the measurement, the EUT is activated and is set to operate at maximum power. The RF load attached to the EUT antenna terminal is 50Ohm.

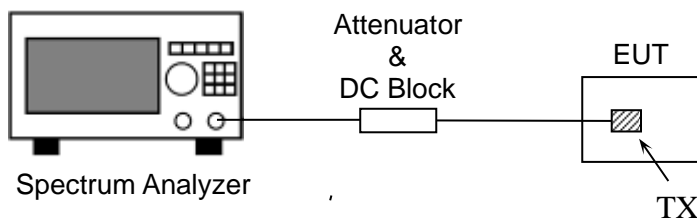

5.3.3 Test Result

GFSK Modulation test result:

Channel	Frequency (MHz)	Test Result(MHz)
11	2405	0.849
18	2440	0.925
26	2480	0.855

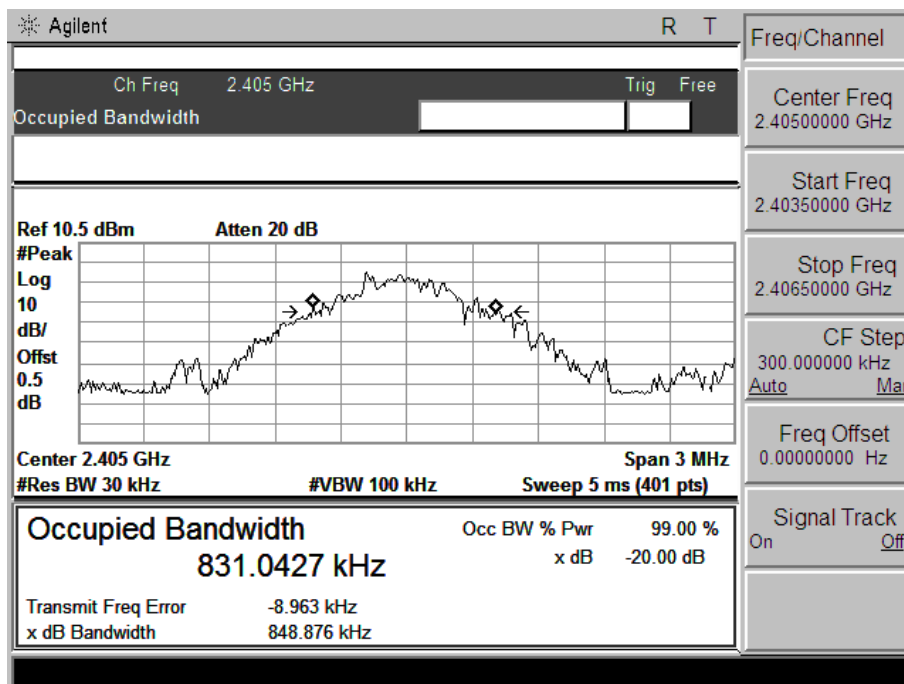

CH Low

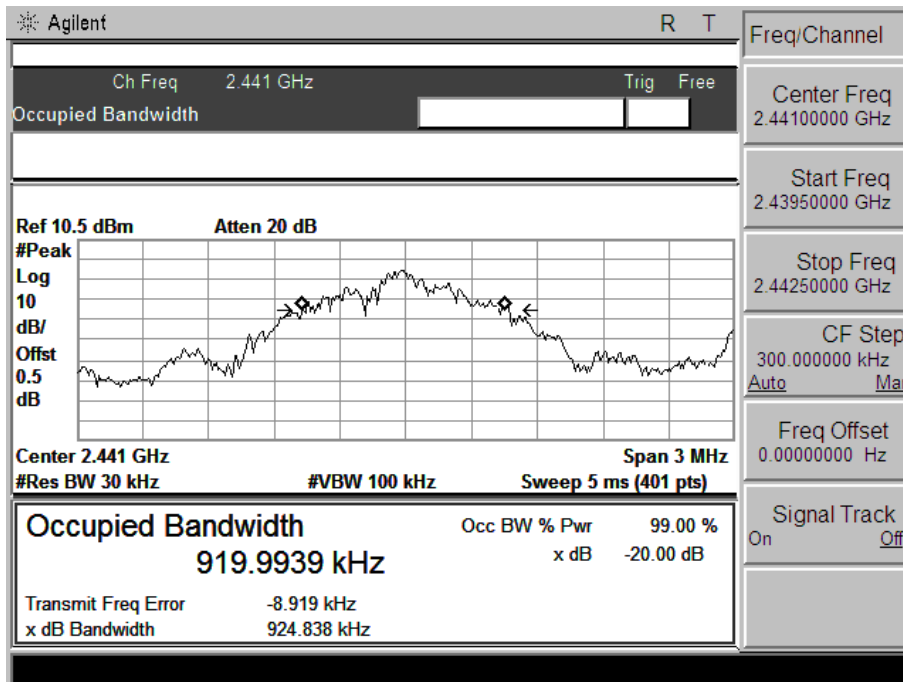

CH MID

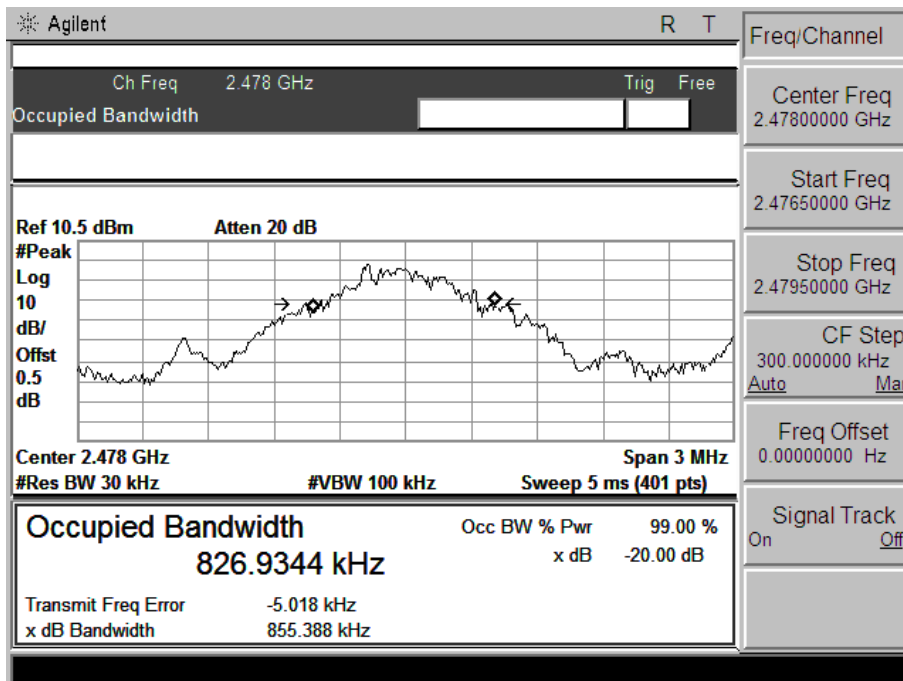

CH High

5.4 Antenna Requirement

5.4.1 Definition

An intentional radiator shall be designed to ensure that no antenna other than that furnished by the responsible party shall be used with the device, An analysis of the EUT was performed to determine compliance with FCC Section 15.203. This section requires specific handling and control of antennas used for devices subject to regulations.

5.4.2 Evaluation Criteria

Section 15.203 of the rules states that the subject device must meet at least one of the following criteria:

- (a) Antenna must be permanently attached to the unit.
- (b) Antenna must use a unique type of connector to attach to the EUT.
- (c) Unit must be professionally installed. Installer shall be responsible for verifying that the correct antenna is employed with the unit.

5.4.3 Evaluation Results

The EUT has one integral antenna arrangement, which was permanently attached and the antenna gain is 0 dBi, fulfill the requirement of this section.

5.5 Restricted Frequency Bands

5.5.1 Test Requirement

In any 100 kHz bandwidth outside the frequency band in which the spread spectrum or digitally modulated intentional radiator is operating, the radio frequency power that is produced by the intentional radiator shall be at least 20 dB below that in the 100 kHz bandwidth within the band that contains the highest level of the desired power. In addition, radiated emissions which fall in the restricted bands, as defined in §15.205(a), must also comply with the radiated emission limits specified in §15.209(a) (see §15.205(c)).

5.5.2 Test Configuration

Test Setup:

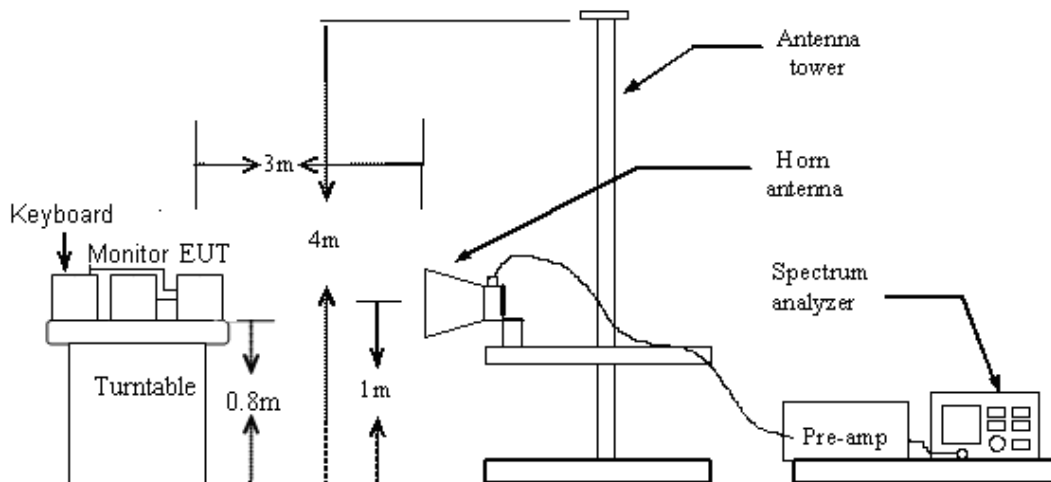

5.5.3 Test Procedure:

1. The EUT was placed on the top of a rotating table 0.8 meters above the ground at a 3 meter chamber. The table was rotated 360 degrees to determine the position of the highest radiation.
2. The EUT was set 3 meters away from the interference-receiving antenna, which was mounted on the top of a variable-height antenna tower.
3. The antenna height is varied from one meter to four meters above the ground to determine the maximum value of the field strength. Both horizontal and vertical polarizations of the antenna are set to make the measurement.
4. For each suspected emission, the EUT was arranged to its worst case and then the antenna was tuned to heights from 1 meter to 4 meters and the table was turned from 0 degrees to 360 degrees to find the maximum reading.

5.5.4 Test Result

Pass

Note: All test modes are performed, only the worst case is recorded in this report.

Please refer the following plots.

EUT:	Letv GAMEPAD	M/N:	LeWGP-201
Mode:	GFSK-CH0	Polarization	Horizontal
Test by:	John	Power:	DC 5V by USB Port
Temperature: / Humidity	24.7°C / 51.9%	Test date:	2016-04-24

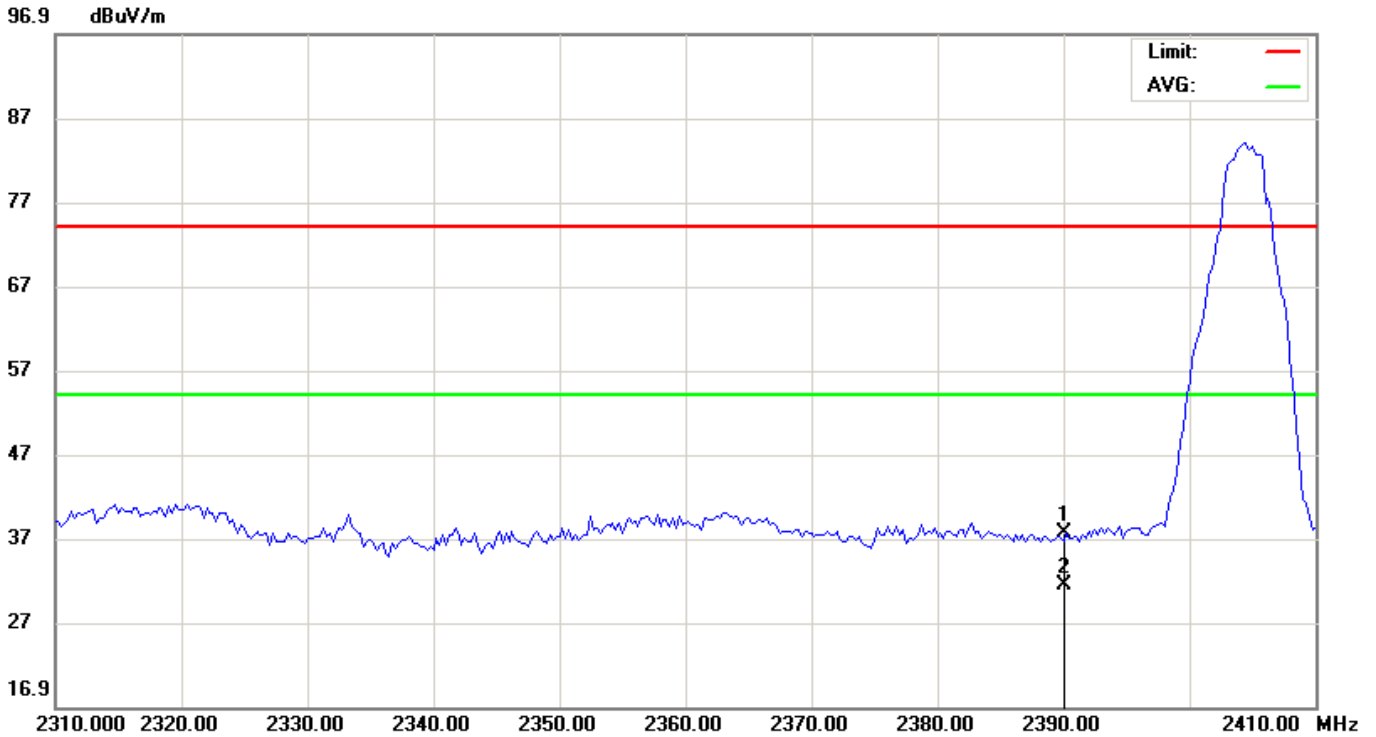

No.	Mk.	Freq. MHz	Reading Level dBuV	Correct Factor dB	Measure- ment dBuV/m	Limit dBuV/m	Over dB	Detector	Antenna Height cm	Table Degree degree	Comment
1		2390.000	46.06	-8.43	37.63	74.00	-36.37	peak			
2	*	2390.000	39.87	-8.43	31.44	54.00	-22.56	AVG			

*:Maximum data x:Over limit !:over margin

EUT:	Letv GAMEPAD	M/N:	LeWGP-201
Mode:	GFSK-CH0	Polarization	Vertical
Test by:	John	Power:	DC 5V by USB Port
Temperature: / Humidity	24.7°C / 51.9%	Test date:	2016-04-24

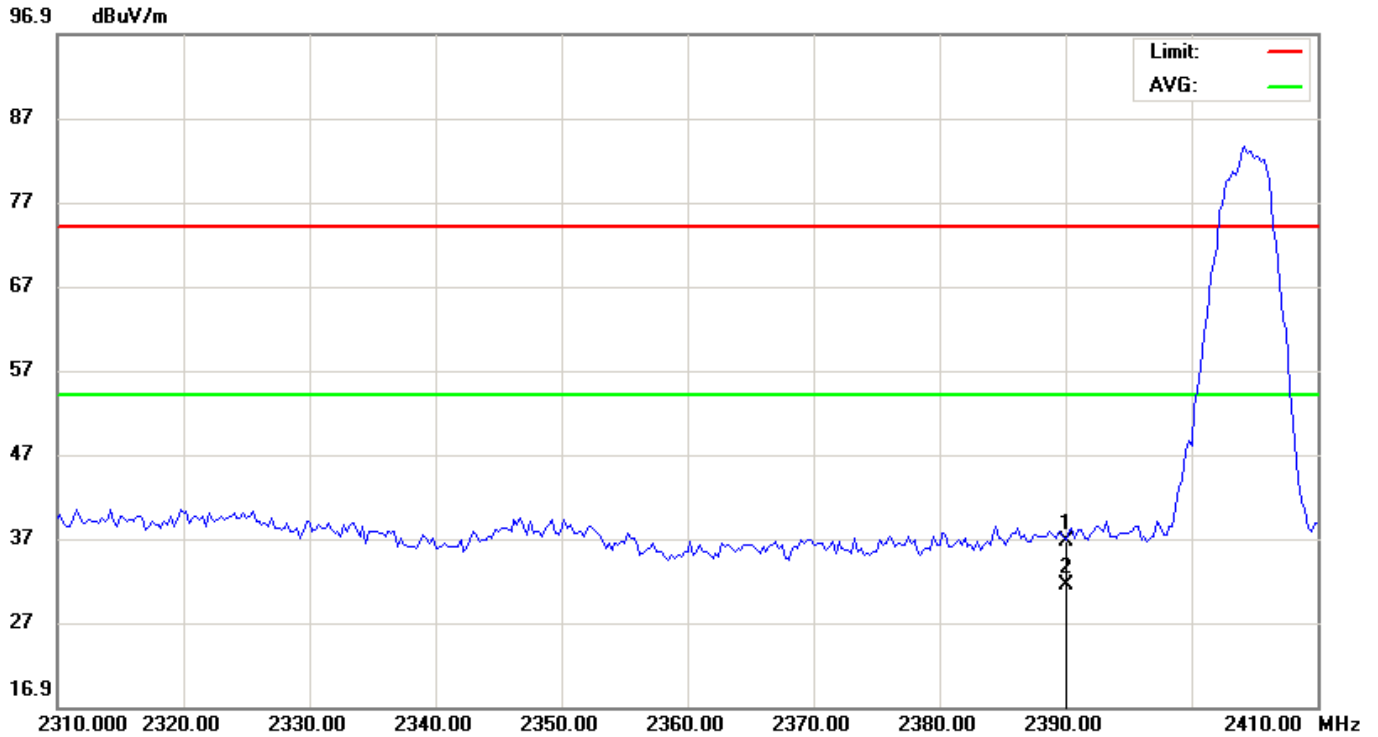

No.	Mk.	Freq.	Reading Level	Correct Factor	Measurement	Limit	Over	Antenna Height	Table Degree	
		MHz	dBuV	dB	dBuV/m	dBuV/m	dB	cm	degree	Comment
1		2390.000	44.98	-8.43	36.55	74.00	-37.45			peak
2	*	2390.000	39.84	-8.43	31.41	54.00	-22.59			AVG

*:Maximum data x:Over limit !:over margin

EUT:	Letv GAMEPAD	M/N:	LeWGP-201
Mode:	GFSK-CH78	Polarization	Horizontal
Test by:	John	Power:	DC 5V by USB Port
Temperature: / Humidity	24.7°C / 51.9%	Test date:	2016-04-24

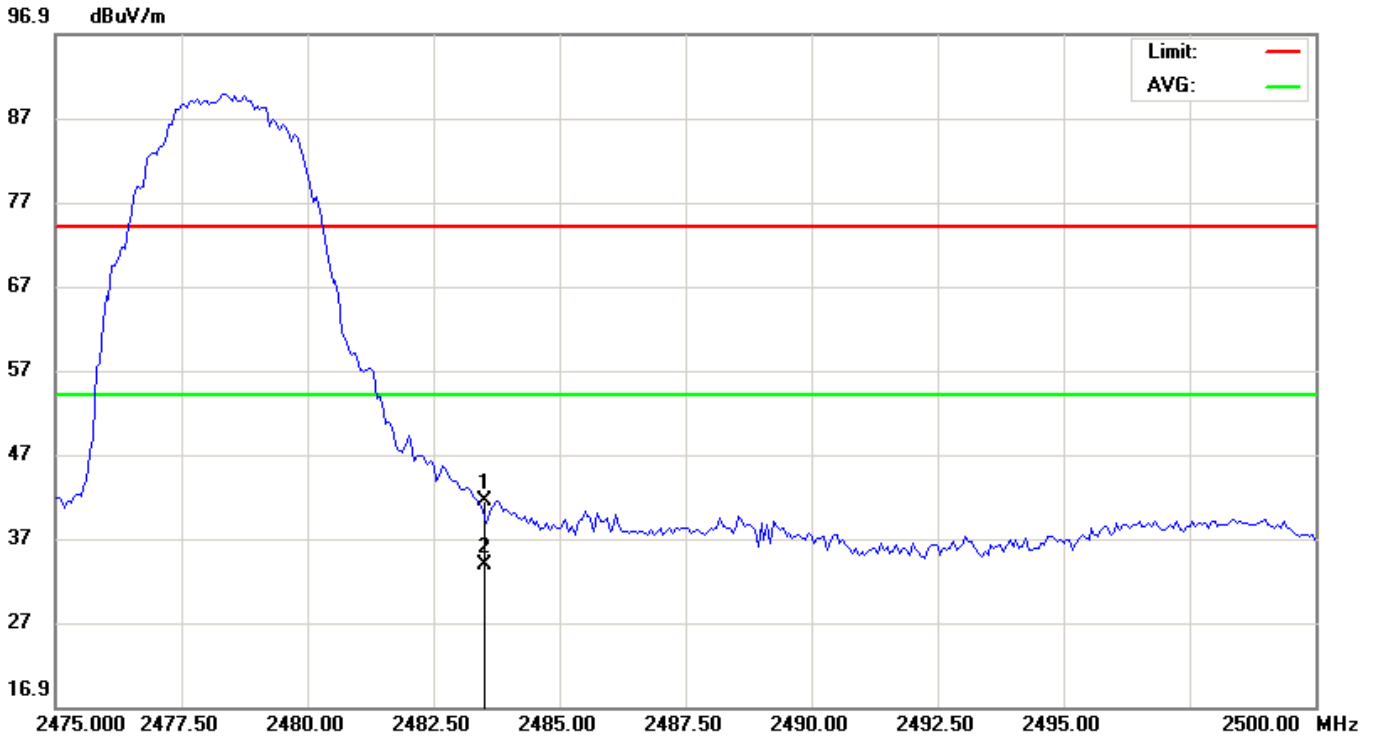

No.	Mk.	Freq.	Reading Level	Correct Factor	Measurement	Limit	Over	Antenna Height	Table Degree	
		MHz	dBuV	dB	dBuV/m	dBuV/m	dB	cm	degree	Comment
1		2483.500	49.68	-8.29	41.39	74.00	-32.61			peak
2	*	2483.500	42.16	-8.29	33.87	54.00	-20.13			AVG

*:Maximum data x:Over limit !:over margin

EUT:	Letv GAMEPAD	M/N:	LeWGP-201
Mode:	GFSK-CH78	Polarization	Vertical
Test by:	John	Power:	DC 5V by USB Port
Temperature: / Humidity	24.7°C / 51.9%	Test date:	2016-04-24

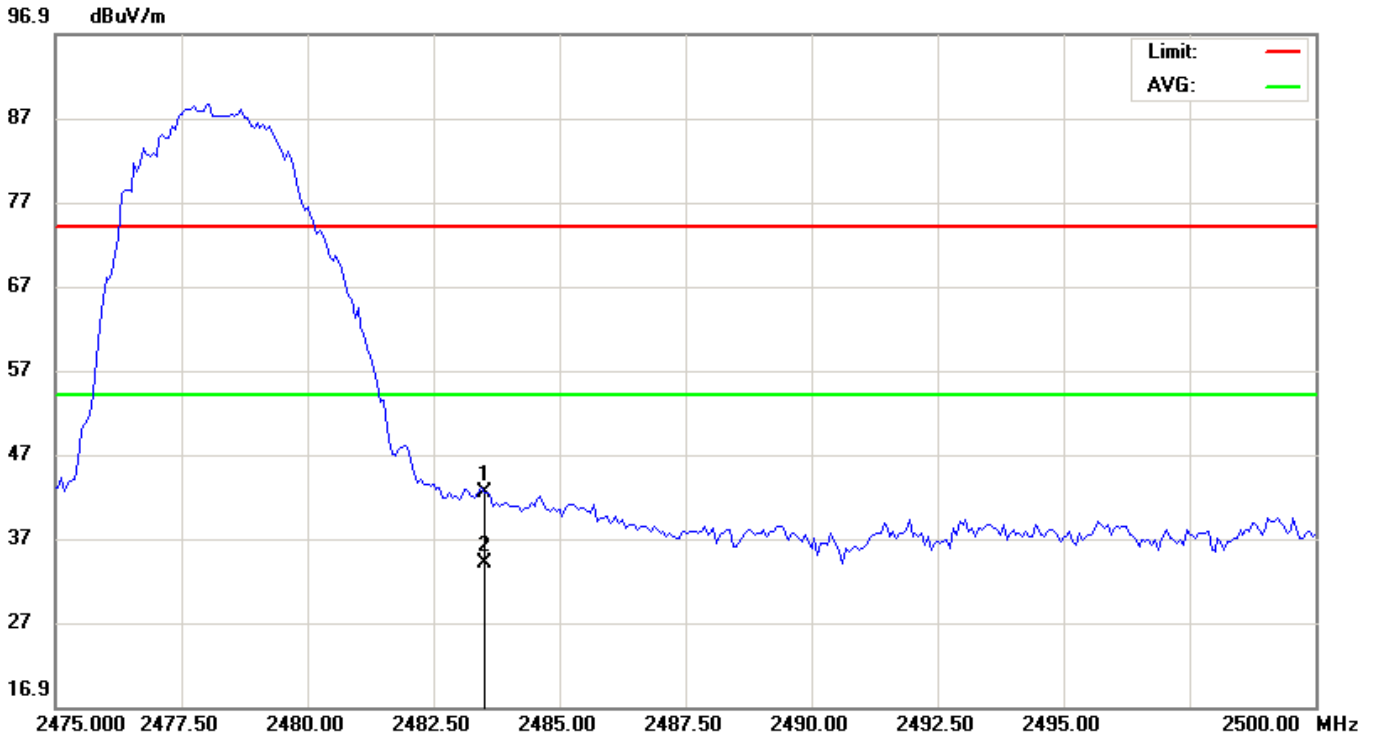

No.	Mk.	Freq. MHz	Reading Level dBuV	Correct Factor dB	Measure- ment dBuV/m	Limit dBuV/m	Over dB	Detector	Antenna Height cm	Table Degree	Comment
1		2483.500	50.61	-8.29	42.32	74.00	-31.68	peak			
2	*	2483.500	42.31	-8.29	34.02	54.00	-19.98	AVG			

*:Maximum data x:Over limit !:over margin

-----END OF REPORT-----