

# **WT32-ETH01**

**DATASHEET**

Version 1.2

23 October, 2019

## **Disclaimer and Copyright Notice**

Information in this paper, including URL references, is subject to change without prior notice.

This document is provided “as is” with no warranties whatsoever, including any warranty of merchantability, non-infringement, fitness for any particular purpose, or any warranty otherwise arising out of any proposal, specification or sample. All liability, including liability for infringement of any patent rights, relating to use of information in this document is disclaimed. No licenses, either express or implied, by estoppel or otherwise, to any intellectual property rights are granted herein.

The Wi-Fi Alliance Member logo is a trademark of the Wi-Fi Alliance.

All trade names, trademarks and registered trademarks mentioned in this document are property of their respective owners, and are hereby acknowledged.

---

## Revision History

Version	Modified By	Date	Reason	Release Notes
V1.0	Mark	Oct. 21, 2019	Created the document	First release.
V1.1	Lin Fuliang	Oct. 23, 2019	Modified the document	Added the "Product Functions" chapter.

---

## Contents

WT32-ETH01 .....	1
1. Overview.....	6
2. Features.....	6
3. Hardware Specifications.....	8
3.1 System Block Diagram .....	8
3.2 Product Images.....	8
3.3 Pin Descriptions.....	9
3.4 Power Supply Characteristics .....	10
3.4.1 Supply Voltage .....	10
3.4.2 Power Supply Modes.....	10
4. Instructions.....	11
4.1 Power-on Instruction.....	11
4.2 Indicator Instruction .....	11
4.3 Usage Instruction.....	11
4.4 Network Port Indicator Instruction .....	11
5. Interface Descriptions.....	12
6. Product Functions.....	12
6.1 Default parameters .....	12
6.2 Basic Functions .....	13
6.2.1 Set IP/ Subnet Mask/ Gateway.....	13
6.2.2 Restore Factory Settings.....	13
6.2.3 Firmware upgrades.....	14
6.2.4 AT Command Function Settings .....	14
6.2.5 Data Transmission Function .....	14
6.3 Socket Function .....	14
6.3.1 TCP Client.....	14
6.3.2 TCP Server.....	15
6.3.3 UDP Client.....	15
6.3.4 UDP Server.....	15
6.4 Serial Port Function .....	15
6.4.1 At Command Settings .....	15

- 6.5 Bluetooth Function .....15
  - 6.5.1 Bluetooth Data Transmission .....15
- 6.6 Wifi Function .....16
  - 6.6.1 Internet Access .....16
- 6.7 Cable Network Access Function .....16
  - 6.7.1 Internet Access .....16

## 1. Overview

WT32-ETH01 is an embedded serial port to Ethernet module based on ESP32 series launched by Wireless-Tag Technology Co. Limited. Integrating an optimized TCP/IP protocol stack, it makes it easy for users to accomplish the network access of embedded devices and greatly reduces the development time cost. Moreover, the module is designed to be compatible with half pads and through-hole connectors. As the board width of it is the generic width, the module can be directly welded to boards, or connectors, or even breadboards, which is convenient for users to apply in different scenes.

Esp32 series IC is the SOC integrated with 2.4GHz Wi-Fi and Bluetooth dual modes, with ultra-high RF performance, stability, versatility, reliability, and ultra-low power consumption.

## 2. Features

Table 1: Product specifications

Category	Items	Product specifications
Wi-Fi	RF certifications	FCC/CE/RoHS
	Protocols	802.11 b/g/n/e/i (802.11n, Up to 150 Mbps)
		A-MPDU and A-MSDU aggregation, 0.4_ s guard interval support
	Frequency range	2.4~2.5 GHz
Bluetooth	Protocols	Bluetooth v4.2 BR/EDR and BLE standards
	Radio	NZIF receiver with -97 dBm sensitivity
Hardware	Network port specifications	RJ45, 10/100Mbps, Cross-direct connection adaptive
	Serial baud rate	80~5000000
	On-board flash	32Mbit
	Operating voltage	5V or 3.3V
	Operating current	Average: 80mA
	Supply current	Minimum: 500 mA

	Operating temperature	-40°C~+85°C
	Ambient temperature	Normal temperature
	Packaging	Half pad/ Through-hole connector( Optional)
Software	Wi-Fi mode	Station/softAP/SoftAP+station/P2P
	Wi-Fi security mechanisms	WPA/WPA2/WPA2-Enterprise/WPS
	Encryption types	AES/RSA/ECC/SHA
	Firmware update	Remote OTA upgrade via network
	Software development	SDK used for further development
	Networking protocol	IPv4、TCP/UDP
	IP access methods	Static IP、DHCP (Default)
	Transparent transmission modes	TCP Server/TCP Client/UDP Server/UDP Client
	User configurations	AT+ commands set

3. Hardware Specifications

3.1 System Block Diagram

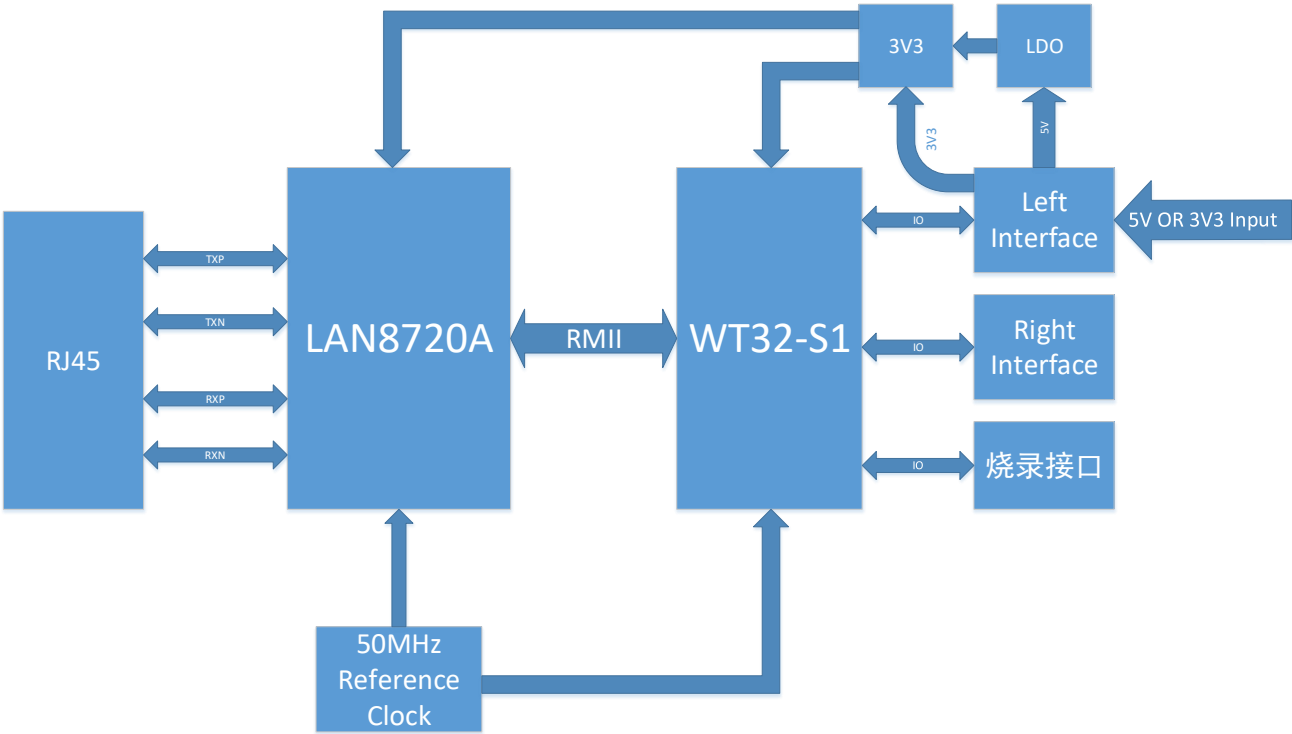
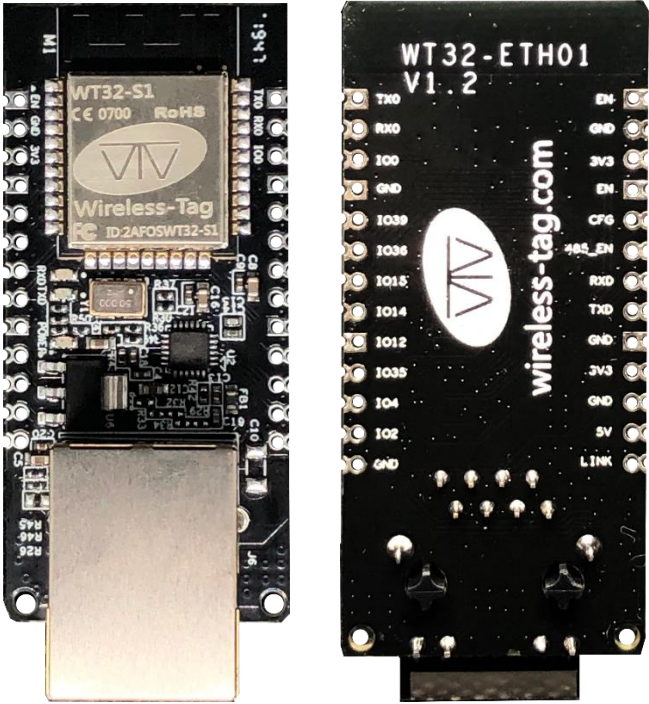

Figure 1: System Block Diagram

3.2 Product Images





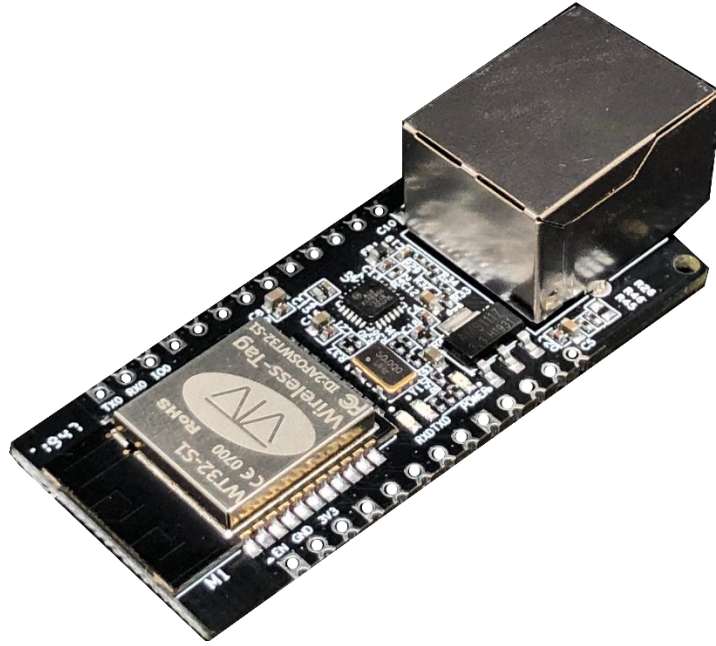

Figure 2: Product Images

### 3.3 Pin Descriptions

Table 1: Debugging/Burning Interfaces

Pin	Name	Description
1	EN <sup>1</sup>	Reserved debugging/burning interface; Active-high enable
2	GND	Reserved debugging/burning interface; GND
3	3V3	Reserved debugging/burning interface; 3V3
4	TXD	Reserved debugging/burning interface; IO1, TXD0
5	RXD	Reserved debugging/burning interface; IO3, RXD0
6	IO0	Reserved debugging/burning interface; IO0

Table 2: IO Descriptions

Pin	Name	Description
1	EN <sup>1</sup>	Active-high enable
2	CFG	IO32, CFG
3	485_EN	IO33, RS485 Enable pin

4	RXD	IO5, RXD2
5	TXD	IO17, TXD2
6	GND	GND
7	3V3 <sup>2</sup>	3V3 Power supply
8	GND	GND
9	5V <sup>2</sup>	5V Power supply
10	LINK	Network connection indicator pin
11	GND	GND
12	IO39 <sup>3</sup>	IO39, Input only
13	IO36 <sup>3</sup>	IO36, Input only
14	IO15	IO15
15	IO14	IO14
16	IO12	IO12
17	IO35	IO35, Input only
18	IO4	IO4
19	IO2	IO2
20	GND	GND

Note 1: The module enables high level by default.

Note 2: Power supply makes a binary choice between 3V3 and 5V.

Note 3: IO39, IO35 and IO36 only support input.

### 3.4 Power Supply Characteristics

#### 3.4.1 Supply Voltage

You can make a binary choice between 3V3 and 5V for power supply voltage of the module.

#### 3.4.2 Power Supply Modes

Users can choose from the following modes flexibly according to their needs:

1) Through hole (Welding pins):

- Power supply with Dupont line connection;

- Power supply with breadboard connection;

- 2) Half pad (Directly welded to the board): Power supply of user board.

#### 4. Instructions

##### 4.1 Power-on Instruction

If the Dupont line connection is used: Find the 3V3 or 5V power input port, and connect the corresponding voltage to it ; when LED1 indicator lights up, it indicates that power is on.

##### 4.2 Indicator Instruction

- LED1: Power light, when the power supply is normal, the indicator light is on;
- LED3: Serial port indicator, RXD2(IO5) When there is data flow, the indicator light is on;
- LED4: Serial port indicator, TXD2(IO17) When there is data flow, the indicator light is on;

##### 4.3 Usage Instruction

Users can choose from three ways of use according to their needs:

- 1) Through hole (Welding pins): Dupont line connection;
- 2) Through hole (Welding pins): breadboard connection;
- 3) Half pad: Users can directly weld the module on their own board.

##### 4.4 Network Port Indicator Instruction

Table 3: Network Port Indicator Descriptions

Network Port Indicator	Function	Description
Green Indicator	Connection status indication	when properly connected to the network, the green light is on.
Yellow Indicator	Data indication	The indicator flashes when the module receives or sends data, including receiving network broadcast package.

5. Interface Descriptions

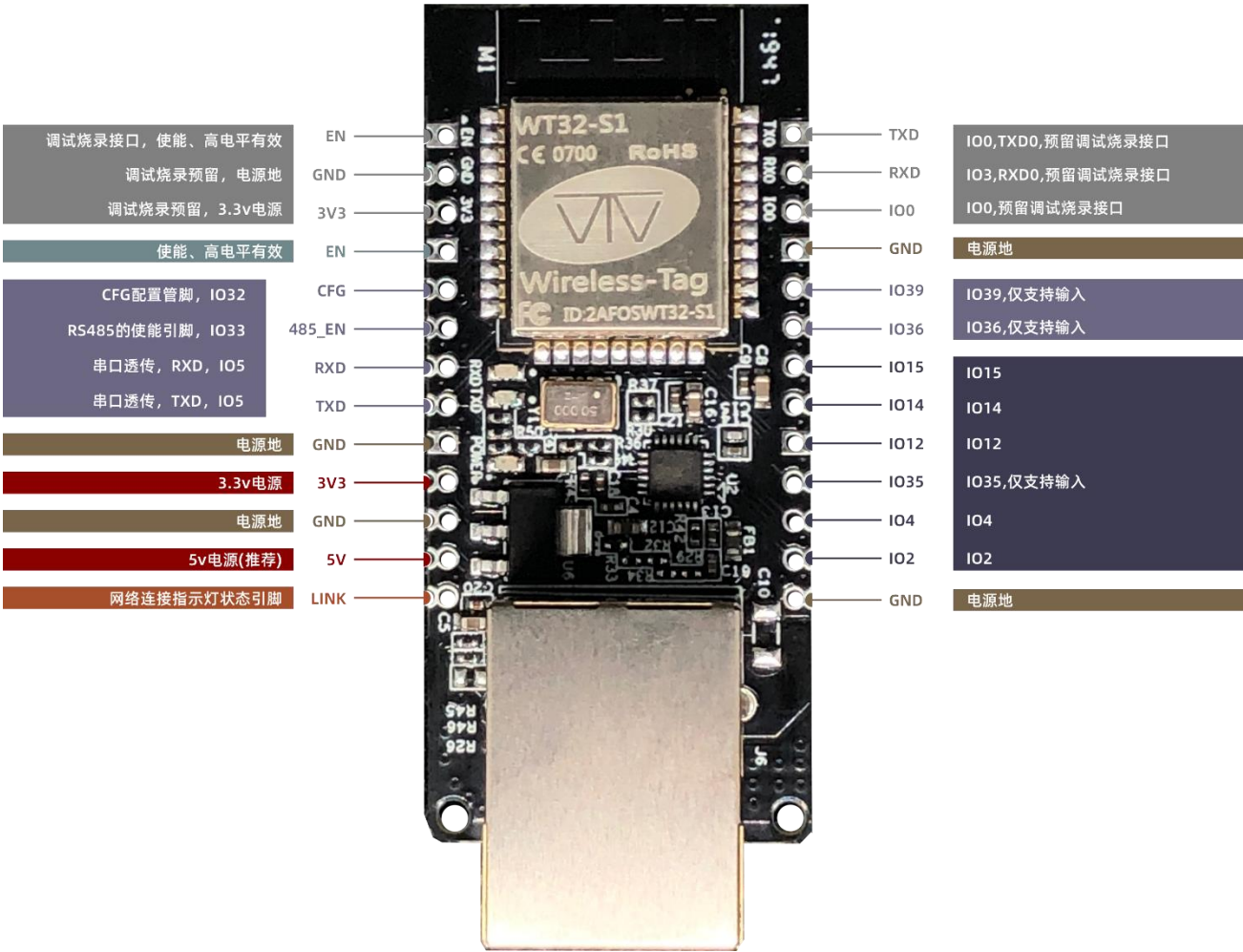

6. Product Functions

6.1 Default parameters

Items	Descriptions
Port Baud Rate	115200
Serial port parameters	None/8/1
Transparent Transmission Channel	Serial to Ethernet transparent transmission channel

## **6.2 Basic Functions**

### **6.2.1 Set IP/ Subnet Mask/ Gateway**

1. IP address is the identity representation of the module in the LAN, which is unique in the LAN, so it can not be repeated with other devices in the same LAN. There are two ways to obtain the IP address of the module: static IP and DHCP / dynamic IP.

#### **a. Static IP**

Static IP needs to be set manually by the user. In the process of setting, attention should be paid to write IP, subnet mask and gateway at the same time. Static IP is suitable for scenarios where IP and devices need to be counted and correspond to each other. You should pay attention to the correspondence of IP address, subnet mask and gateway when setting. To use static IP, you need to set each module and ensure that the IP address is not repeated with other network devices in the LAN.

#### **b. DHCP/Dynamic IP**

The main function of DHCP / Dynamic IP is to dynamically obtain IP address, gateway address, DNS server address and other information from the gateway host, so as to avoid the tedious steps of setting IP address. It is applicable to scenarios where there is no requirement for IP, and it is not required to have a one-to-one correspondence between IP and module.

Note: The module cannot be set to DHCP when directly connected to the computer. Generally, the computer does not have the ability to assign IP addresses. If the module is set as DHCP directly connected to the computer, it will cause the module to be in the state of waiting for IP address allocation all the time, which will cause the module to fail to perform normal transmission. The module default static IP: 192.168.0.7

2. The subnet mask is mainly used to determine the network number and host number of the IP address, indicate the number of subnets, and determine whether the module is in the subnet. The subnet mask must be set properly. The commonly used class C subnet mask is 255.255.255.0. The network number is the first 24 bits, the host number is the last 8 bits, and the number of subnets is 255. If the module IP is within the range of 255, it is considered that the module IP is in the subnet.

3. Gateway refers to the network number of the current IP address of the module. If the module connects to the external network by accessing devices such as routers, the gateway is the IP address of the router. If the setting is wrong, the external network cannot be connected correctly. If you do not connect to devices such as routers, you do not need to set it. It's OK by default.

### **6.2.2 Restore Factory Settings**

1. Restore factory settings by AT command: restore factory settings via AT+ RESTORE.

2. Restore factory settings by hardware: CFG to ground, restart the module.

### 6.2.3 Firmware upgrades

OTA remote upgrade is the way for modules to upgrade firmware, through which more application functions can be obtained.

- a. Firmware upgrade can be connected to the network through wired network or wifi.
- b. Operate GPIO2 to ground, restart the module, and enter OTA upgrade mode.
- c. After the upgrade is completed, disconnect GPIO2 from the ground, restart the module, and it enters the normal working mode.

OTA firmware upgrade instructions: when the firmware is being downloaded, the serial port TXD indicator flashes quickly; when the download is being upgraded, the serial port TXD indicator is always on; when the upgrade is successful, the serial port TXD and RXD indicators are always on; when the upgrade fails, the serial port TXD indicator flashes slowly.

### 6.2.4 AT Command Function Settings

Users can set functions of the module by inputting AT commands through serial ports.

Refer to the ESP32 AT instruction set for details.

### 6.2.5 Data Transmission Function

The module has four data transmission ports: Serial port, Wifi, Ethernet and Bluetooth.

Users can use AT commands to combine the four data ports in pairs for data transmission.

Use AT+PASSCHANNEL command to set/query the module's transparent transmission channel. After the setting is complete, the module needs to be restarted to take effect.

## 6.3 Socket Function

The Socket working mode of the module is divided into four types: TCP Client, TCP Server, UDP Client, and UDP Server, which can be set by AT command.

For AT command operation, please refer to esp32 wired module AT command routine v1.2.

### 6.3.1 TCP Client

1. TCP Client provides client connection for TCP network services. It initiates connection request and establish connection to the server to realize the interaction between serial port data and server data. According to the relevant provisions of TCP protocol, TCP client has the difference between connection and disconnection, so as to ensure the reliable exchange of data. Usually used for data interaction between devices and servers, it is the most common way of networking communication.
2. When the module connects TCP server as a TCP client, it needs to pay attention to the parameters such as the target IP / domain name and the target port number. Target IP can be of a local device in the same LAN. It can

also be an IP address from a different LAN or an IP address across the public network. If connecting to a server across the public network, the server is required to have a public IP.

### 6.3.2 TCP Server

It is usually used for communication with TCP client in LAN. It is suitable for the scenario where there is no server in the LAN and there are multiple computers or mobile phones requesting data from the server. The same as TCP Client, TCP server has the difference between connection and disconnection to ensure reliable exchange of data.

### 6.3.3 UDP Client

UDP Client is a connectionless transport protocol, providing transaction-oriented simple and unreliable information transmission services. There is no connection establishment or disconnection, and data can be sent to each other only by specifying IP and port. It is usually used in data transmission scenarios where there is no requirement for the packet loss rate, the data packets are small and the transmission frequency is relatively fast, and the data is transferred to the specified IP.

### 6.3.4 UDP Server

UDP Server means that the source IP address is not verified on the basis of ordinary UDP. After receiving a UDP packet, the destination IP is changed to the data source IP and port number. When sending data, send it to the IP and port number of the most recent communication

This mode is usually used in data transmission scenarios where multiple network devices need to communicate with the module and do not want to use TCP due to the high speed and frequency.

## 6.4 Serial Port Function

### 6.4.1 At Command Settings

Users can input AT commands through serial ports to set functions for a module.

### 6.4.2 Transmitting Serial Data

The user makes the module enter the data transmission mode through AT command. The module can directly transfer serial port data to the corresponding data transmission end (wifi, Ethernet or Bluetooth) through the set passthrough channel.

## 6.5 Bluetooth Function

### 6.5.1 Bluetooth Data Transmission

Through the existing Bluetooth function of the module, the module can obtain Bluetooth data, and through the set pass-through channel, the Bluetooth data can be directly transferred to the corresponding data transmission end (wifi, Ethernet or serial port).

## **6.6 Wifi Function**

### **6.6.1 Internet Access**

The module wifi is connected to the Internet or LAN through a router. The user configures the socket function through the AT command. The module can establish a TCP/UDP connection and then access the user's designated server.

## **6.7 Cable Network Access Function**

Stable network connection can be obtained through wired network to ensure stable network data acquisition.

### **6.7.1 Internet Access**

The module is connected to the Internet or LAN through a wired network. The user configures the socket function through the AT command. The module can establish a TCP/UDP connection and then access the user's designated server.



## **Federal Communication Commission Statement (FCC, U.S.)**

This equipment has been tested and found to comply with the limits for a Class B digital device, pursuant to Part 15 of the FCC Rules. These limits are designed to provide reasonable protection against harmful interference in a residential installation. This equipment generates, uses and can radiate radio frequency energy and, if not installed and used in accordance with the instructions, may cause harmful interference to radio communications. However, there is no guarantee that interference will not occur in a particular installation. If this equipment does cause harmful interference to radio or television reception, which can be determined by turning the equipment off and on, the user is encouraged to try to correct the interference by one of the following measures:

- Reorient or relocate the receiving antenna.
- Increase the separation between the equipment and receiver.
- Connect the equipment into an outlet on a circuit different from that to which the receiver is connected.
- Consult the dealer or an experienced radio/TV technician for help.

This device complies with Part 15 of the FCC Rules. Operation is subject to the following two conditions: (1) This device may not cause harmful interference, and (2) this device must accept any interference received, including interference that may cause undesired operation.

### **FCC Caution:**

Any changes or modifications not expressly approved by the party responsible for compliance could void the user's authority to operate this equipment.

### **FCC Radiation Exposure Statement:**

This equipment complies with FCC radiation exposure limits set forth for an uncontrolled environment. This equipment should be installed and operated with minimum distance 20cm between the radiator & your body.

## **IMPORTANT NOTES**

### **Co-location warning:**

This transmitter must not be co-located or operating in conjunction with any other antenna or transmitter.

### **OEM integration instructions:**

This device is intended only for OEM integrators under the following conditions:

The transmitter module may not be co-located with any other transmitter or antenna. The module shall be only used with the external antenna(s) that has been originally tested and certified with this module.

As long as the conditions above are met, further transmitter test will not be required. However, the OEM integrator is still responsible for testing their end-product for any additional compliance requirements required with this module installed (for example, digital device emissions, PC peripheral requirements, etc.).

### **Validity of using the module certification:**

In the event that these conditions cannot be met (for example certain laptop configurations or co-location with another transmitter), then the FCC authorization for this module in combination with the host equipment is no longer considered valid and the FCC ID of the module cannot be used on the final product. In these circumstances, the OEM integrator will be responsible for re-evaluating the end product (including the transmitter) and obtaining a separate FCC authorization.

### **End product labeling:**

The final end product must be labeled in a visible area with the following: "Contains Transmitter Module FCC ID: 2AFOS-WT32-ETH01".

**Information that must be placed in the end user manual:**

The OEM integrator has to be aware not to provide information to the end user regarding how to install or remove this RF module in the user's manual of the end product which integrates this module. The end user manual shall include all required regulatory information/warning as show in this manual.

# Integration instructions for host product manufacturers according to KDB 996369 D03 OEM Manual v01

## 2.2 List of applicable FCC rules

FCC Part 15 Subpart C 15.247 & 15.207 & 15.209

## 2.3 Specific operational use conditions

The module is a Bluetooth module with WiFi & BR&EDR & BLE 2.4G function.

### WiFi Specification:

Operation Frequency: 2412~2462MHz

Number of Channel: 11

Modulation: DSSS, OFDM

Type: PCB Antenna

Gain: 1 dBi

### BR&EDR Specification:

Operation Frequency: 2402~2480MHz

Number of Channel: 79

Modulation: GFSK,  $\pi/4$ -DQPSK, 8DPSK

Type: PCB Antenna

Gain: 1 dBi

### BLE Specification:

Operation Frequency: 2402~2480MHz

Number of Channel: 40

Modulation: GFSK

Type: PCB Antenna

Gain: 1 dBi

The module can be used for mobile or applications with a maximum 1dBi antenna. The host manufacturer installing this module into their product must ensure that the final composite product complies with the FCC requirements by a technical assessment or evaluation to the FCC rules, including the transmitter operation. The host manufacturer has to be aware not to provide information to the end user regarding how to install or remove this RF module in the user's manual of the end product which integrates this module. The end user manual shall include all required regulatory information/warning as show in this manual.

## 2.4 Limited module procedures

Not applicable.

## 2.5 Trace antenna designs

Not applicable. The module has its own antenna, and doesn't need a host's printed board microstrip trace antenna etc.

## 2.6 RF exposure considerations

The module must be installed in the host equipment such that at least 20cm is maintained between the antenna and users' body; and if RF exposure statement or module layout is changed, then the host product manufacturer required to take responsibility of the module through a change in FCC ID or new application. The FCC ID of the module cannot be used on the final product. In these circumstances, the host manufacturer will be responsible for re-evaluating the end product (including the transmitter) and obtaining a separate FCC authorization

## 2.7 Antennas

Antenna Specification are as follows:

Type: PCB Antenna

Gain: 1 dBi

This device is intended only for host manufacturers under the following conditions:

The transmitter module may not be co-located with any other transmitter or antenna;

The module shall be only used with the internal antenna(s) that has been originally tested and certified with this module. The antenna must be either permanently attached or employ a 'unique' antenna coupler.

As long as the conditions above are met, further transmitter test will not be required. However, the host manufacturer is still responsible for testing their end-product for any additional compliance requirements required with this module installed (for example, digital device emissions, PC peripheral requirements, etc.).

## **2.8 Label and compliance information**

Host product manufacturers need to provide a physical or e-label stating “Contains Transmitter Module FCC ID: 2AFOS-WT32-ETH01” with their finished product.

## **2.9 Information on test modes and additional testing requirements**

### **BR&EDR**

Operation Frequency: 2402~2480MHz  
Number of Channel: 79  
Modulation: GFSK,  $\pi/4$ -DQPSK, 8DPSK

### **BLE**

Operation Frequency: 2402~2480MHz  
Number of Channel: 40  
Modulation: GFSK

### **WIFI**

Operation Frequency: 2412~2462MHz  
Number of Channel: 11  
Modulation: DSSS, OFDM

Host manufacturer must perform test of radiated & conducted emission and spurious emission, etc according to the actual test modes for a stand-alone modular transmitter in a host, as well as for multiple simultaneously transmitting modules or other transmitters in a host product. Only when all the test results of test modes comply with FCC requirements, then the end product can be sold legally.

### **2.10 Additional testing, Part 15 Subpart B disclaimer**

The modular transmitter is only FCC authorized for FCC Part 15 Subpart C 15.247 & 15.207 & 15.209 and that the host product manufacturer is responsible for compliance to any other FCC rules that apply to the host not covered by the modular transmitter grant of certification. If the grantee markets their product as being Part 15 Subpart B compliant (when it also contains unintentional-radiator digital circuitry), then the grantee shall provide a notice stating that the final host product still requires Part 15 Subpart B compliance testing with the modular transmitter installed.