



FCC Test Report

FCC ID:2AFNZ-JM101XXX

Product : 2 in 1 tablet PC

Trade Name : N/A

Model Number : JM101B

Serial Model : JM101A00, JM101A01, JM101A10, JM101A11, JM101A21, JM101A40, JM101A41, JM101A50, JM101A51, JM101A61, JM101A, JM101B00, JM101B01, JM101B10, JM101B11, JM101B21, JM101B40, JM101B41, JM101B50, JM101B51, JM101B61, JM101X-YY (X: Range A~Z or blank, A indicate Folio type of keyboard; B indicate Hinge type of keyboard. And so on. Y: Range 00~99 or blank, indicate the difference in Product color, etc.)

Report No. : NTEK-2015NT06222095F1

Prepared for

JING MOLD ELECTRONICS TECHNOLOGY(SHENZHEN)CO.,LTD.

Xinqiao,3rd Industrial Estate,Shajing Baoan,Shenzhen,China

Prepared by

Shenzhen NTEK Testing Technology Co., Ltd.

1/F, Building E, Fenda Science Park, Sanwei Community, Xixiang Street,
Bao'an District, Shenzhen P.R. China

Tel.: +86-0755-61156588 Fax.: +86-0755-61156599

Website: www.ntek.org.cn

TEST RESULT CERTIFICATION

Applicant's name : JING MOLD ELECTRONICS TECHNOLOGY
(SHENZHEN)CO.,LTD.
Address : Xinqiao,3rd Industrial Estate,Shajing Baoan,Shenzhen,China
Manufacturer's Name : JING MOLD ELECTRONICS TECHNOLOGY
(SHENZHEN)CO.,LTD.
Address : Xinqiao,3rd Industrial Estate,Shajing Baoan,Shenzhen,China

Product description

Product name : 2 in 1 tablet PC
Model and/or type reference : JM101B
Serial Model : Refer to Page 1
FCC Part15B:01 Oct.2014
Standards : ANSI C63.4:2014

This device described above has been tested by NTEK, and the test results show that the equipment under test (EUT) is in compliance with Part 15 of FCC Rules. And it is applicable only to the tested sample identified in the report.

This report shall not be reproduced except in full, without the written approval of NTEK, this document may be altered or revised by NTEK, personnel only, and shall be noted in the revision of the document.

Date of Test :
Date (s) of performance of tests : 22 Jun.2015~20 Aug.2015
Date of Issue : 20 Aug.2015
Test Result : **Pass**

Testing Engineer : _____



(Allen Liu)

Technical Manager : _____

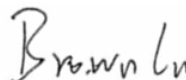

(Brown Lu)

Authorized Signatory : _____

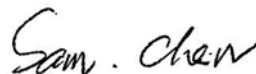

(Sam Chen)

Table of Contents	Page
1 . TEST SUMMARY	4
1.1 TEST FACILITY	5
1.2 MEASUREMENT UNCERTAINTY	5
2 . GENERAL INFORMATION	6
2.1 GENERAL DESCRIPTION OF EUT	6
2.2 DESCRIPTION OF TEST SETUP	8
2.3 DESCRIPTION TEST PERIPHERAL AND EUT PERIPHERAL	9
2.4 MEASUREMENT INSTRUMENTS LIST	10
3 . EMC EMISSION TEST	12
3.1 CONDUCTED EMISSION MEASUREMENT	12
3.1.1 POWER LINE CONDUCTED EMISSION	12
3.1.2 TEST PROCEDURE	13
3.1.3 TEST SETUP	13
3.1.4 EUT OPERATING CONDITIONS	13
3.1.5 TEST RESULTS	14
3.2 RADIATED EMISSION MEASUREMENT	18
3.2.1 LIMITS OF RADIATED EMISSION MEASUREMENT	18
3.2.2 TEST PROCEDURE	18
3.2.3 TEST SETUP	19
3.2.4 EUT OPERATING CONDITIONS	20
3.2.5 TEST RESULTS	21
3.2.6 TEST RESULTS(1000~12400MHz)	25
4 . EUT TEST PHOTO	26

1. TEST SUMMARY

Test procedures according to the technical standards:

EMC Emission				
Standard	Test Item	Limit	Judgment	Remark
FCC Part15B:2014 ANSI C63.4: 2014	Conducted Emission	Class B	PASS	
	Radiated Emission	Class B	PASS	

NOTE:

- (1) 'N/A' denotes test is not applicable in this Test Report
- (2) For client's request and manual description, the test will not be executed.

1.1 TEST FACILITY

NTEK Testing Technology Co., Ltd

Add. : 1/F, Building E, Fenda Science Park, Sanwei Community, Xixiang Street, Bao'an District, Shenzhen P.R. China.

FCC Registration Number:238937; IC Registration Number:9270A-1

CNAS Registration Number:L5516

1.2 MEASUREMENT UNCERTAINTY

The reported uncertainty of measurement $y \pm U$, where expanded uncertainty U is based on a standard uncertainty multiplied by a coverage factor of $k=2$, providing a level of confidence of approximately **95** %.

A. Conducted Measurement :

Test Site	Method	Measurement Frequency Range	U , (dB)	NOTE
NTEKC01	ANSI	150 KHz ~ 30MHz	3.2	

B. Radiated Measurement :

Test Site	Method	Measurement Frequency Range	U , (dB)	NOTE
NTEKA01	ANSI	30MHz ~ 1000MHz	4.7	
		1GHz ~12.4GHz	5.0	

2. GENERAL INFORMATION

2.1 GENERAL DESCRIPTION OF EUT

Equipment	2 in 1 tablet PC	
Model Name	JM101B	
Additional Model Number(s)	Refer to Page 1	
Model Difference	All models used the same PCBA board, the difference is only in the collocation keyboard type, product color ,etc.	
Product Description	The EUT is a 2 in 1 tablet PC.	
	Connecting I/O port:	HDMI, DC in,USB
	Operation Frequency:	BT:2402~2480 MHz WIFI: 802.11b/g/n(20MHz): 2412~2462MHz 802.11n(40MHz):2422~2452MHz
	Modulation Type:	BT(1Mbps): GFSK BT EDR(2Mbps): $\pi/4$ -DQPSK BT EDR(3Mbps): 8-DPSK IEEE 802.11b : DSSS (CCK, QPSK, DBPSK) IEEE 802.11g/n (HT20/HT40) : OFDM(64QAM, 16QAM, QPSK, BPSK)
Power Source	AC Voltage	
Adapter	Mode : F12US0500200A Input: 100-240V~, 50/60Hz, 0.5A Max Output: 5V $\overline{\text{---}}$, 2.0A	
Battery	DC 3.8V, 7400mAh	

2.1.1 DESCRIPTION OF TEST MODES

To investigate the maximum EMI emission characteristics generates from EUT, the test system was pre-scanning tested base on the consideration of following EUT operation mode or test configuration mode which possible have effect on EMI emission level. Each of these EUT operation mode(s) or test configuration mode(s) mentioned above was evaluated respectively.

Pretest Mode	Description
Mode 1	RUNNNG Mode
Mode 2	USB PLAYING Mode
Mode 3	TF PLAYING Mode
Mode 4	HDMI Mode

For Conducted Test	
Final Test Mode	Description
Mode 1	RUNNNG Mode

For Radiated Test	
Final Test Mode	Description
Mode 1	RUNNNG Mode

Note: Final Test Mode: Through Pre-scan, find the mode 1 is the worse case. Only the worst case mode is recorded in the report.

2.2 DESCRIPTION OF TEST SETUP

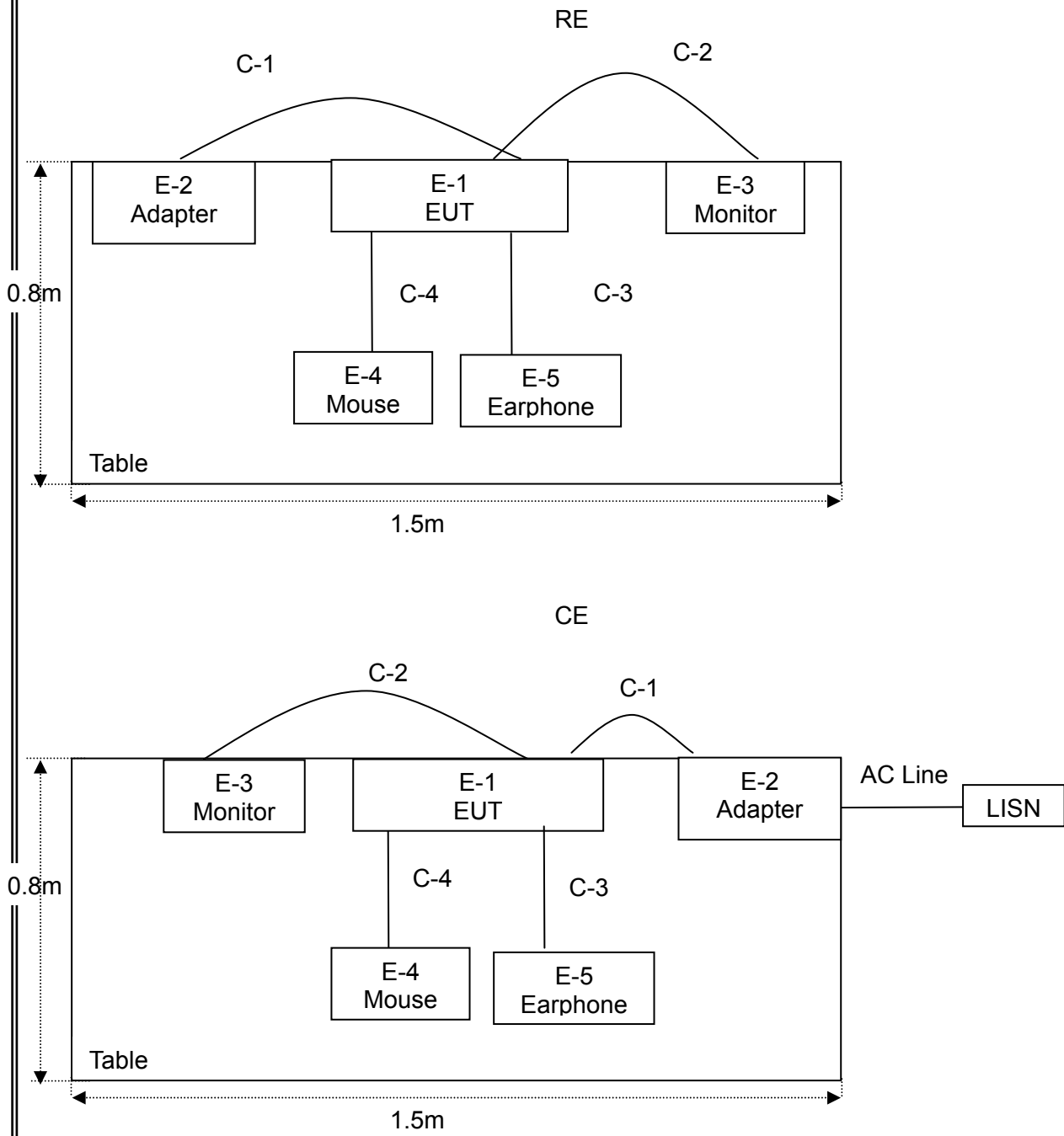

2.3 DESCRIPTION TEST PERIPHERAL AND EUT PERIPHERAL

The EUT has been tested as an independent unit together with other necessary accessories or support units. The following support units or accessories were used to form a representative test configuration during the tests.

Item	Equipment	Brand	Model/Type No.	Series No.	Note
E-1	2 in 1 tablet PC	N/A	JM101B	N/A	EUT
E-2	Adapter	N/A	BSC60-190250	N/A	
E-3	Monitor	SONY	KDL-24EX520	6450750	
E-4	Mouse	DELL	MS111-P	cn-011d3v-71581-11e-1th7	
E-5	Earphone	N/A	2688	N/A	

Item	Shielded Type	Ferrite Core	Length	Note
C-1	NO	NO	1.2m	
C-2	NO	NO	1.0m	
C-3	NO	NO	1.0m	
C-4	NO	NO	1.0m	

Note:

- (1) The support equipment was authorized by Declaration of Confirmation.
- (2) For detachable type I/O cable should be specified the length in cm in 『Length』 column.
- (3) “YES” means “shielded” “with core”; “NO” means “unshielded” “without core”.

2.4 MEASUREMENT INSTRUMENTS LIST

2.4.1 CONDUCTED TEST SITE

Item	Kind of Equipment	Manufacturer	Type No.	Serial No.	Last calibration	Calibrated until	Calibration period
1	LISN	R&S	ENV216	101313	Jul. 06, 2015	Jul. 05, 2016	1 year
2	LISN	SCHWARZBECK	NNLK 8129	8129245	Dec. 25, 2014	Dec. 24, 2015	1 year
3	Pulse Limiter	SCHWARZBECK	VTSD 9561F	9716	Dec. 25, 2014	Dec. 24, 2015	1 year
4	50Ω Switch	ANRITSU CORP	MP59B	6200983704	Jul. 06, 2015	Jul. 05, 2016	1 year
5	Test Cable	N/A	C01	N/A	Jul. 06, 2015	Jul. 05, 2016	1 year
6	Test Cable	N/A	C02	N/A	Jul. 06, 2015	Jul. 05, 2016	1 year
7	Test Cable	N/A	C03	N/A	Jul. 06, 2015	Jul. 05, 2016	1 year
8	EMI Test Receiver	R&S	ESCI	101160	Jul. 06, 2015	Jul. 05, 2016	1 year
9	Passive Voltage Probe	ESH2-Z3	R&S	100196	Jul. 06, 2015	Jul. 05, 2016	1 year
10	Absorbing Clamp	R&S	MDS-21	100423	Jul. 06, 2015	Jul. 05, 2016	1 year

1	LISN	R&S	ENV216	101313	Jul. 06, 2014	Jul. 05, 2015	1 year
4	50Ω Switch	ANRITSU CORP	MP59B	6200983704	Jul. 06, 2014	Jul. 05, 2015	1 year
5	Test Cable	N/A	C01	N/A	Jul. 06, 2014	Jul. 05, 2015	1 year
6	Test Cable	N/A	C02	N/A	Jul. 06, 2014	Jul. 05, 2015	1 year
7	Test Cable	N/A	C03	N/A	Jul. 06, 2014	Jul. 05, 2015	1 year
8	EMI Test Receiver	R&S	ESCI	101160	Jul. 06, 2014	Jul. 05, 2015	1 year
9	Passive Voltage Probe	ESH2-Z3	R&S	100196	Jul. 06, 2014	Jul. 05, 2015	1 year
10	Absorbing Clamp	R&S	MDS-21	100423	Jul. 06, 2014	Jul. 05, 2015	1 year

2.4.2 RADIATED TEST SITE

Item	Kind of Equipment	Manufacturer	Type No.	Serial No.	Last calibration	Calibrated until	Calibration period
1	Bilog Antenna	TESEQ	CBL6111D	31216	Jul. 06, 2015	Jul. 05, 2016	1 year
2	Test Cable	N/A	R-01	N/A	Jul. 06, 2015	Jul. 05, 2016	1 year
3	Test Cable	N/A	R-02	N/A	Jul. 06, 2015	Jul. 05, 2016	1 year
4	EMI Test Receiver	R&S	ESCI-7	101318	Jun. 06, 2015	Jun. 05, 2016	1 year
5	Antenna Mast	EM	SC100_1	N/A	N/A	N/A	N/A
6	Turn Table	EM	SC100	060531	N/A	N/A	N/A
7	50Ω Switch	Anritsu Corp	MP59B	6200983705	Jul. 06, 2015	Jul. 05, 2016	1 year
8	Spectrum Analyzer	Aglient	E4407B	MY45108040	Jul. 06, 2015	Jul. 05, 2016	1 year
9	Horn Antenna	EM	EM-AH-10180	2011071402	Jul. 06, 2015	Jul. 05, 2016	1 year
10	Amplifier	EM	EM-30180	060538	Dec. 22, 2014	Dec. 21, 2015	1 year
11	Loop Antenna	ARA	PLA-1030/B	1029	Jun. 06, 2015	Jun. 05, 2016	1 year

1	Bilog Antenna	TESEQ	CBL6111D	31216	Jul. 06, 2014	Jul. 05, 2015	1 year
2	Test Cable	N/A	R-01	N/A	Jul. 06, 2014	Jul. 05, 2015	1 year
3	Test Cable	N/A	R-02	N/A	Jul. 06, 2014	Jul. 05, 2015	1 year
7	50Ω Switch	Anritsu Corp	MP59B	6200983705	Jul. 06, 2014	Jul. 05, 2015	1 year
8	Spectrum Analyzer	Aglient	E4407B	MY45108040	Jul. 06, 2014	Jul. 05, 2015	1 year
9	Horn Antenna	EM	EM-AH-10180	2011071402	Jul. 06, 2014	Jul. 05, 2015	1 year

3. EMC EMISSION TEST

3.1 CONDUCTED EMISSION MEASUREMENT

3.1.1 POWER LINE CONDUCTED EMISSION (Frequency Range 150KHz-30MHz)

FREQUENCY (MHz)	Class A (dBuV)		Class B (dBuV)	
	Quasi-peak	Average	Quasi-peak	Average
0.15 -0.5	79.00	66.00	66 - 56 *	56 - 46 *
0.50 -5.0	73.00	60.00	56.00	46.00
5.0 -30.0	73.00	60.00	60.00	50.00

Note:

- (1) The tighter limit applies at the band edges.
- (2) The limit of " * " marked band means the limitation decreases linearly with the logarithm of the frequency in the range.

The following table is the setting of the receiver

Receiver Parameters	Setting
Attenuation	10 dB
Start Frequency	0.15 MHz
Stop Frequency	30 MHz
IF Bandwidth	9 kHz

3.1.2 TEST PROCEDURE

- a. The EUT was placed 0.8 meters from the horizontal ground plane with EUT being connected to the power mains through a line impedance stabilization network (LISN). All other support equipments powered from additional LISN(s). The LISN provide 50 Ohm/ 50uH of coupling impedance for the measuring instrument.
- b. Interconnecting cables that hang closer than 40 cm to the ground plane shall be folded back and forth in the center forming a bundle 30 to 40 cm long.
- c. I/O cables that are not connected to a peripheral shall be bundled in the center. The end of the cable may be terminated, if required, using the correct terminating impedance. The overall length shall not exceed 1 m.
- d. LISN at least 80 cm from nearest part of EUT chassis.
- e. For the actual test configuration, please refer to the related Item –EUT Test Photos.

3.1.3 TEST SETUP

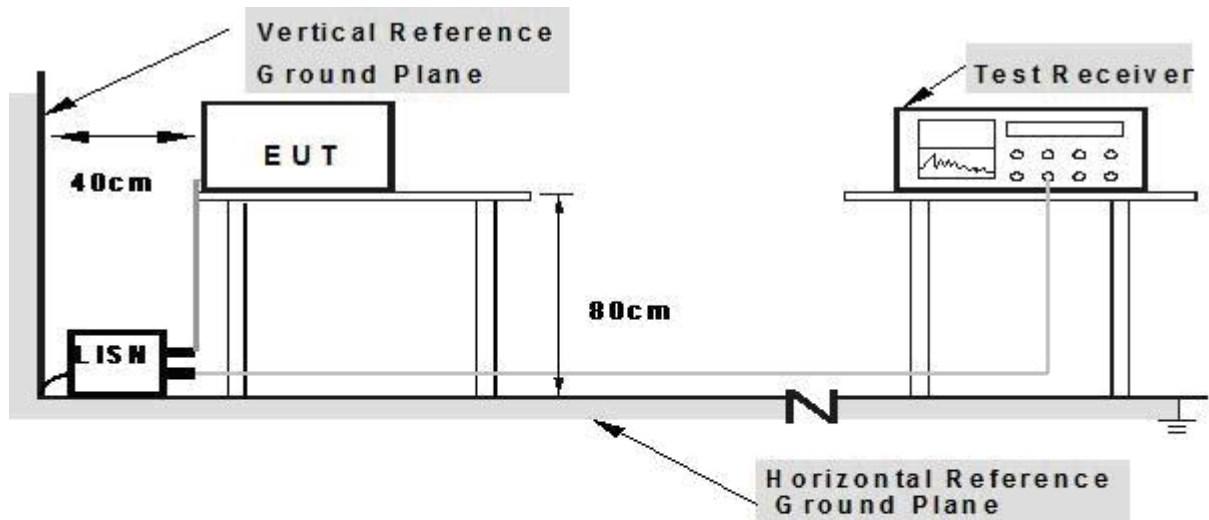

- Note: 1. Support units were connected to second LISN.**
2. Both of LISNs (AMN) are 80 cm from EUT and at least 80 from other units and other metal planes

3.1.4 EUT OPERATING CONDITIONS

The EUT tested system was configured as the statements of 2.3 Unless otherwise a special operating condition is specified in the follows during the testing.

3.1.5 TEST RESULTS

EUT :	2 in 1 tablet PC	Model Name. :	JM101B
Temperature :	26 °C	Relative Humidity :	54%
Pressure :	1010hPa	Test Date :	2015-08-13
Test Mode :	Mode1	Phase :	L
Test Voltage :	DC 5V Form Adapter AC 120V/60Hz		

Frequency (MHz)	Reading Level (dBμV)	Correct Factor (dB)	Measure-ment (dBμV)	Limits (dBμV)	Margin (dB)	Remark
0.1940	46.42	9.61	56.03	63.86	-7.83	QP
0.1940	28.41	9.61	38.02	53.86	-15.84	AVG
0.2420	37.41	9.61	47.02	62.02	-15.00	QP
0.2420	26.64	9.61	36.25	52.02	-15.77	AVG
0.3860	37.56	9.63	47.19	58.15	-10.96	QP
0.3860	23.95	9.63	33.58	48.15	-14.57	AVG
0.4620	34.08	9.66	43.74	56.66	-12.92	AVG
0.4620	23.59	9.66	33.25	46.66	-13.41	QP
7.0659	33.08	9.51	42.59	60.00	-17.41	QP
7.0659	23.27	9.51	32.78	50.00	-17.22	AVG
21.3620	28.20	9.86	38.06	60.00	-21.94	QP
21.3620	24.16	9.86	34.02	50.00	-15.98	AVG

Remark:

1. All readings are Quasi-Peak and Average values.
2. Factor = Insertion Loss + Cable Loss.

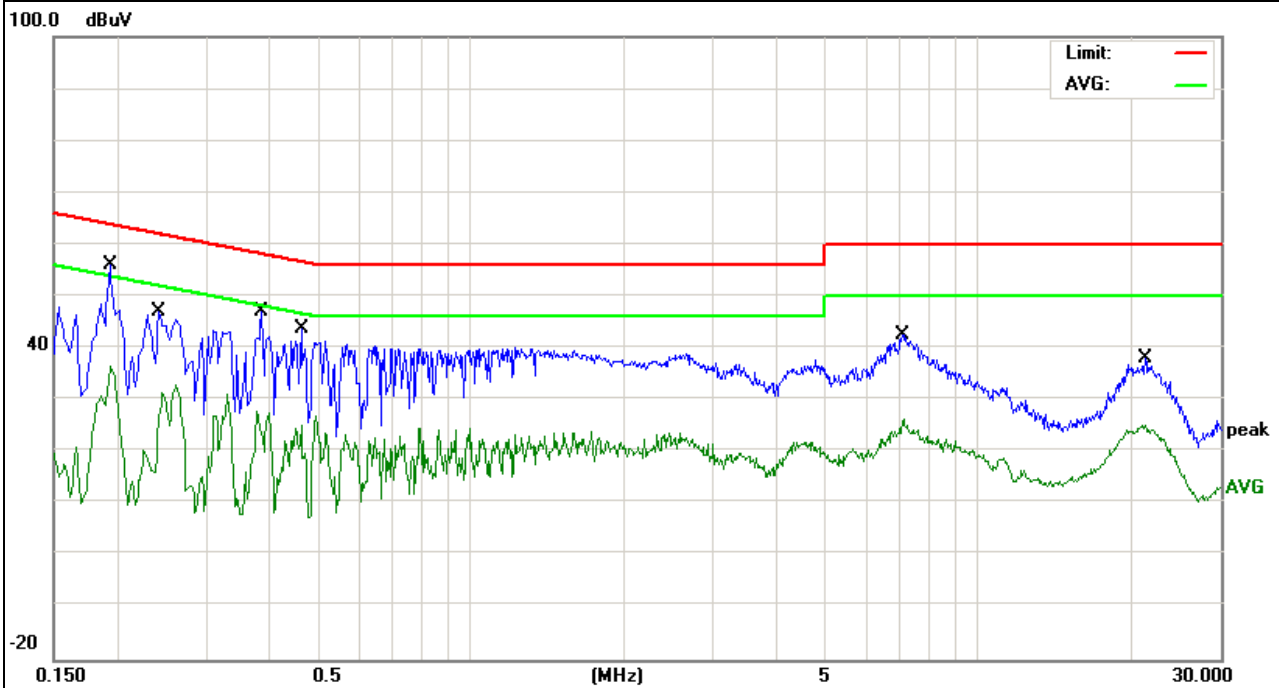

EUT :	2 in 1 tablet PC	Model Name. :	JM101B
Temperature :	26 °C	Relative Humidity :	54%
Pressure :	1010hPa	Test Date :	2015-08-13
Test Mode :	Mode 1	Phase :	N
Test Voltage :	DC 5V Form Adapter AC 120V/60Hz		

Frequency	Reading Level	Correct Factor	Measure-ment	Limits	Margin	Remark
(MHz)	(dBμV)	(dB)	(dBμV)	(dBμV)	(dB)	
0.1900	46.94	9.61	56.55	64.03	-7.48	QP
0.1900	25.32	9.61	34.93	54.03	-19.10	AVG
0.2060	44.43	9.61	54.04	63.36	-9.32	QP
0.2060	27.05	9.61	36.66	53.36	-16.70	AVG
0.3020	40.22	9.62	49.84	60.19	-10.35	QP
0.3020	19.59	9.62	29.21	50.19	-20.98	AVG
0.4620	34.20	9.66	43.86	56.66	-12.80	AVG
0.4620	25.66	9.66	35.32	46.66	-11.34	QP
0.5940	33.20	9.66	42.86	56.00	-13.14	QP
0.5940	23.92	9.66	33.58	46.00	-12.42	AVG
7.1859	34.16	9.52	43.68	60.00	-16.32	QP
7.1859	24.50	9.52	34.02	50.00	-15.98	AVG

Remark:

1. All readings are Quasi-Peak and Average values.
2. Factor = Insertion Loss + Cable Loss.

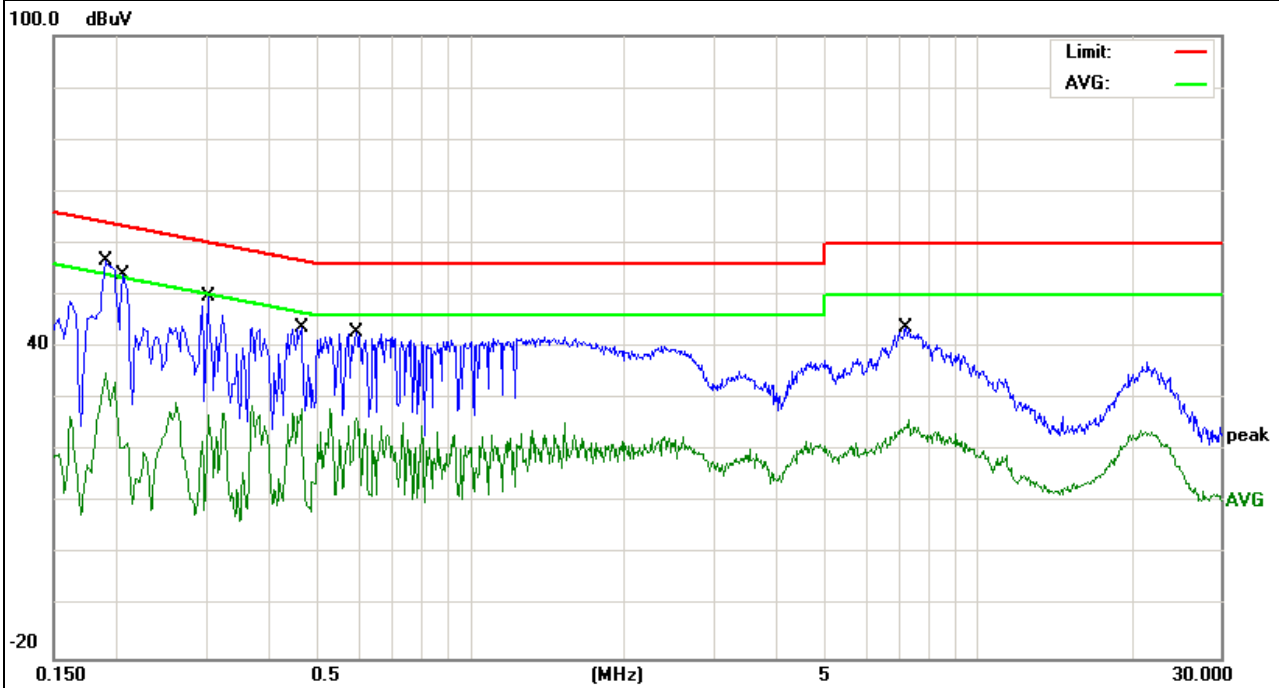

EUT :	2 in 1 tablet PC	Model Name. :	JM101B
Temperature :	26 °C	Relative Humidity :	54%
Pressure :	1010hPa	Test Date :	2015-08-13
Test Mode :	Mode1	Phase :	L
Test Voltage :	DC 5V Form Adapter AC 240V/60Hz		

Frequency (MHz)	Reading Level (dBμV)	Correct Factor (dB)	Measure-ment (dBμV)	Limits (dBμV)	Margin (dB)	Remark
0.1859	40.16	9.61	49.77	64.21	-14.44	QP
0.1859	26.41	9.61	36.02	54.21	-18.19	AVG
0.2220	39.27	9.64	48.91	62.74	-13.83	QP
0.2220	25.38	9.64	35.02	52.74	-17.72	AVG
0.2580	36.88	9.69	46.57	61.49	-14.92	QP
0.2580	23.53	9.69	33.22	51.49	-18.27	AVG
0.5540	33.54	9.78	43.32	56.00	-12.68	AVG
0.5540	23.39	9.78	33.17	46.00	-12.83	QP
0.9899	31.88	9.73	41.61	56.00	-14.39	QP
0.9899	23.85	9.73	33.58	46.00	-12.42	AVG
7.0618	30.35	9.70	40.05	60.00	-19.95	QP
7.0618	24.32	9.70	34.02	50.00	-15.98	AVG

Remark:

1. All readings are Quasi-Peak and Average values.
2. Factor = Insertion Loss + Cable Loss.

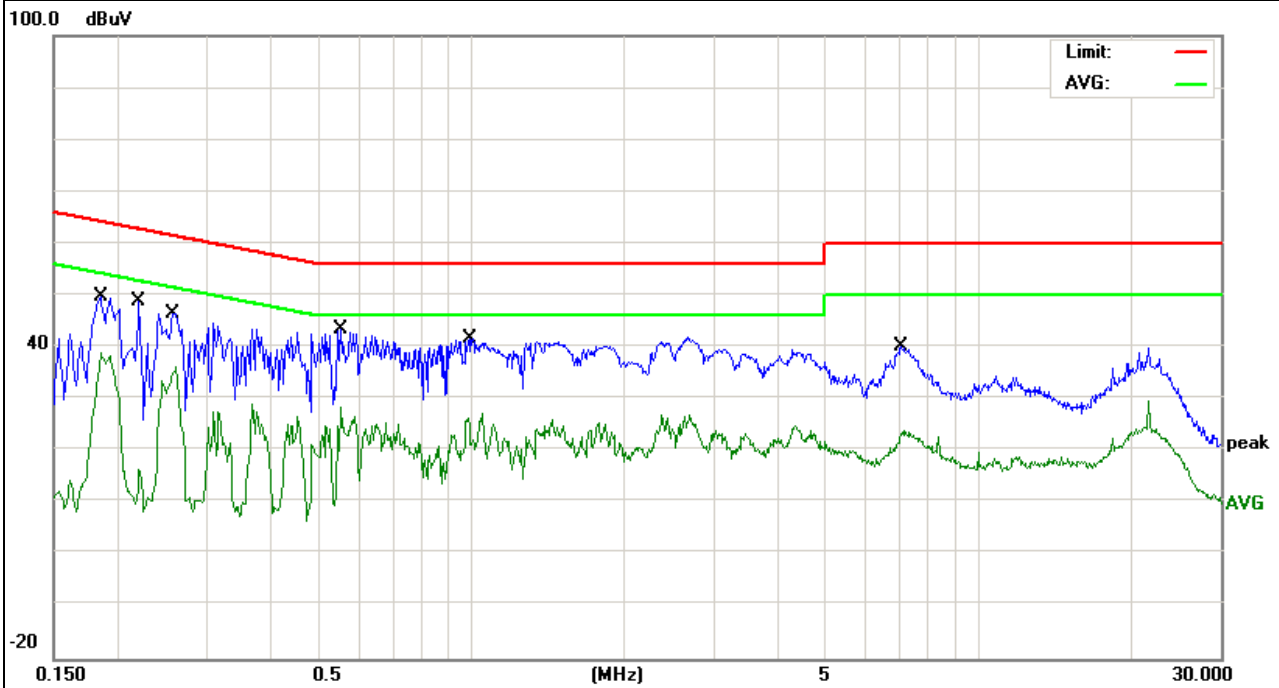

EUT :	2 in 1 tablet PC	Model Name. :	JM101B
Temperature :	26 °C	Relative Humidity :	54%
Pressure :	1010hPa	Test Date :	2015-08-13
Test Mode :	Mode 1	Phase :	N
Test Voltage :	DC 5V Form Adapter AC 240V/60Hz		

Frequency (MHz)	Reading Level (dBμV)	Correct Factor (dB)	Measure-ment (dBμV)	Limits (dBμV)	Margin (dB)	Remark
0.1940	39.95	9.61	49.56	63.86	-14.30	QP
0.1940	25.41	9.61	35.02	53.86	-18.84	AVG
0.2580	39.00	9.62	48.62	61.49	-12.87	QP
0.2580	23.53	9.62	33.15	51.49	-18.34	AVG
0.3780	36.92	9.63	46.55	58.32	-11.77	QP
0.3780	22.95	9.63	32.58	48.32	-15.74	AVG
0.6780	33.47	9.64	43.11	56.00	-12.89	AVG
0.6780	23.98	9.64	33.62	46.00	-12.38	QP
7.3418	33.06	9.53	42.59	60.00	-17.41	QP
7.3418	21.72	9.53	31.25	50.00	-18.75	AVG
22.1419	26.88	9.88	36.76	60.00	-23.24	QP
22.1419	18.14	9.88	28.02	50.00	-21.98	AVG

Remark:

1. All readings are Quasi-Peak and Average values.
2. Factor = Insertion Loss + Cable Loss.

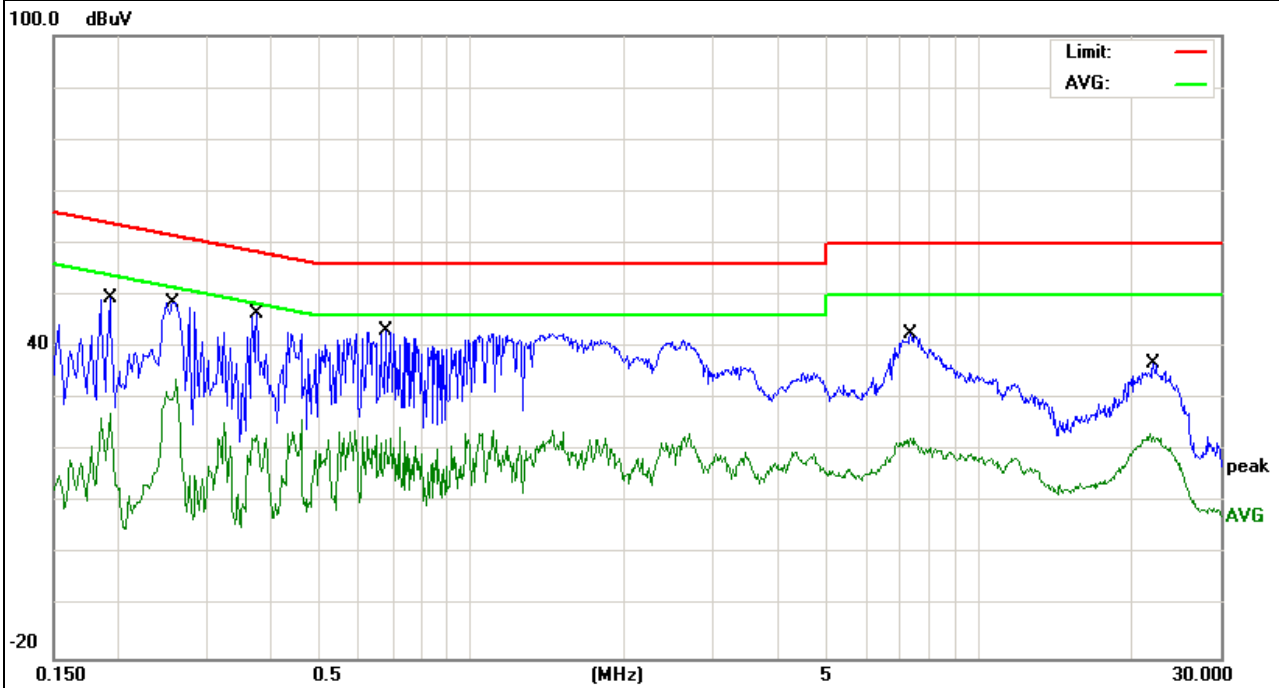

3.2 RADIATED EMISSION MEASUREMENT

3.2.1 LIMITS OF RADIATED EMISSION MEASUREMENT

FREQUENCY (MHz)	Class A (at 10m)	Class B (at 3m)
	dBuV/m	dBuV/m
30 ~ 88	39.0	40.0
88 ~ 216	43.5	43.5
216 ~ 960	46.5	46.0
Above 960	49.5	54.0

Notes:

- (1) The limit for radiated test was performed according to as following:
FCC PART 15B /ICES-003.
- (2) The tighter limit applies at the band edges.
- (3) Emission level (dBuV/m)=20log Emission level (uV/m).

3.2.2 TEST PROCEDURE

Test Arrangement for Radiated Emissions up to 1 GHz

- a. The EUT was placed on the top of a rotating table 0.8 meters above the ground at an accredited test facility. The table was rotated 360 degrees to determine the position of the highest radiation.
- b. The EUT was set 3 meters away from the interference-receiving antenna, which was mounted on the top of a variable-height antenna tower.
- c. The antenna is a broadband antenna, and its height is varied from one meter to four meters above the ground to determine the maximum value of the field strength. Both horizontal and vertical polarizations of the antenna are set to make the measurement.
- d. For each suspected emission, the EUT was arranged to its worst case and then the antenna was tuned to heights from 1 meter to 4 meters and the rotatable table was turned from 0 degrees to 360 degrees to find the maximum reading.

Note: The resolution bandwidth and video bandwidth of test receiver/spectrum analyzer is 120kHz for quasi-peak detection (QP) at frequency below 1GHz.

Test Arrangement for Radiated Emissions above 1 GHz.

- a. The EUT was placed on the top of a rotating table 0.8 meters above the ground at an accredited chamber room. The table was rotated 360 degrees to determine the position of the highest radiation.
- b. The EUT was set 3 meters away from the interference-receiving antenna, which was mounted on the top of a variable-height antenna tower.
- c. The height of antenna can be varied from one meter to four meters, the height of adjustment depends on the EUT height and the antenna 3dB beamwidth both, to detect the maximum value of the field strength. Both horizontal and vertical polarizations of the antenna are set to make the measurement.
- d. For each suspected emission, the EUT was arranged to its worst case and then the antenna was tuned to heights and the rotatable table was turned from 0 degrees to 360 degrees to find the maximum reading.

Note: For the hand-held device, the EUT should be measured for all 3 axes and only the worst case is recorded in the report

During the radiated emission test, the Spectrum Analyzer was set with the following configurations:

Frequency Band (MHz)	Function	Resolution bandwidth	Video Bandwidth
30 to 1000	QP	120 kHz	300 kHz
Above 1000	Peak	1 MHz	1 MHz
	Peak	1 MHz	10 Hz

3.2.3 TEST SETUP

(A) Radiated Emission Test Set-Up Frequency Below 1 GHz

For Radiated Emission 30~1000MHz

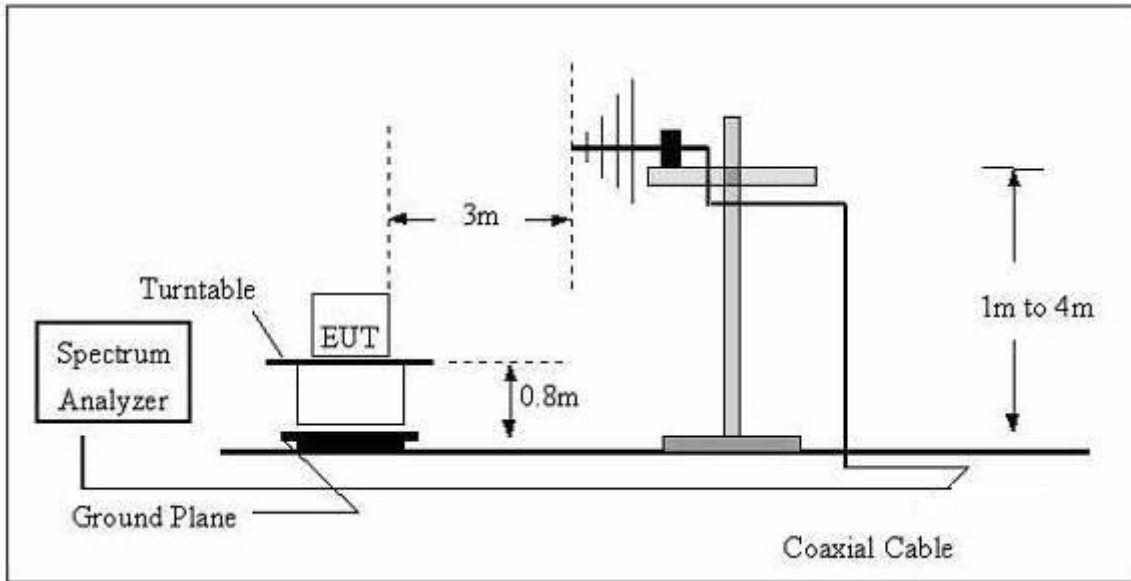

(B) Radiated Emission Test Set-Up Frequency Above 1GHz

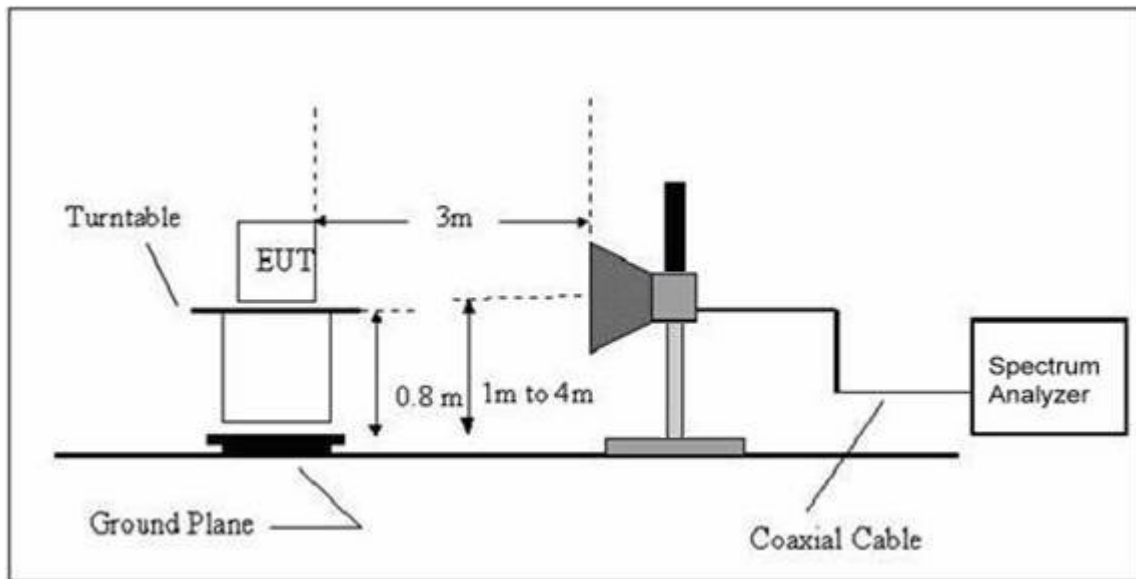

3.2.4 EUT OPERATING CONDITIONS

The EUT tested system was configured as the statements of **2.3** Unless otherwise a special operating condition is specified in the follows during the testing.

3.2.5 TEST RESULTS

TEST RESULTS (30~1000 MHz)

EUT :	2 in 1 tablet PC	Model Name :	JM101B
Temperature :	24 °C	Relative Humidity :	54%
Pressure :	1010 hPa	Test Date :	2015-08-13
Test Mode :	Mode 1-Holster keyboard	Polarization :	Horizontal
Test Power :	AC 120V/60Hz		

Freq. (MHz)	Reading (dBuV)	Factor (dBuV)	Measurement (dBuV)	Limit (dBuV)	Over (dB)	Remark
95.7622	19.18	8.53	27.71	43.50	-15.79	QP
181.9201	17.14	10.64	27.78	43.50	-15.72	QP
301.4223	20.30	14.21	34.51	46.00	-11.49	QP
545.1825	15.26	21.23	36.49	46.00	-9.51	QP
614.2142	15.70	22.70	38.40	46.00	-7.60	QP
742.2586	16.20	25.90	42.10	46.00	-3.90	QP

Remark:

Factor = Antenna Factor + Cable Loss - Amplifier.

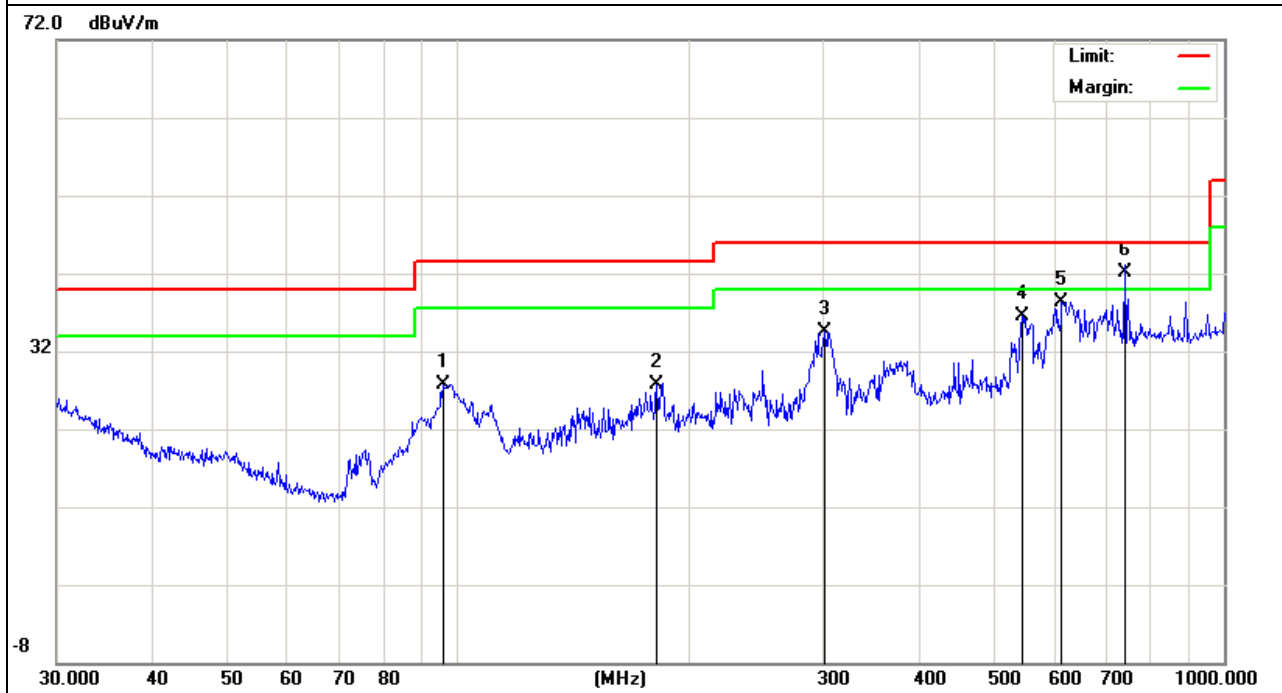

EUT :	2 in 1 tablet PC	Model Name :	JM101B
Temperature :	24 °C	Relative Humidity :	54%
Pressure :	1010 hPa	Test Date :	2015-08-13
Test Mode :	Mode 1-Holster keyboard	Polarization :	Vertical
Test Power :	AC 120V/60Hz		

Freq. (MHz)	Reading (dBuV)	Factor (dBuV)	Measurement (dBuV)	Limit (dBuV)	Over (dB)	Remark
96.7749	23.51	8.64	32.15	43.50	-11.35	QP
109.7960	23.47	9.93	33.40	43.50	-10.10	QP
149.4857	22.17	10.46	32.63	43.50	-10.87	QP
312.1794	15.92	14.66	30.58	46.00	-15.42	QP
470.5232	16.41	19.70	36.11	46.00	-9.89	QP
584.7895	15.55	22.09	37.64	46.00	-8.36	QP

Remark:
Factor = Antenna Factor + Cable Loss - Amplifier.

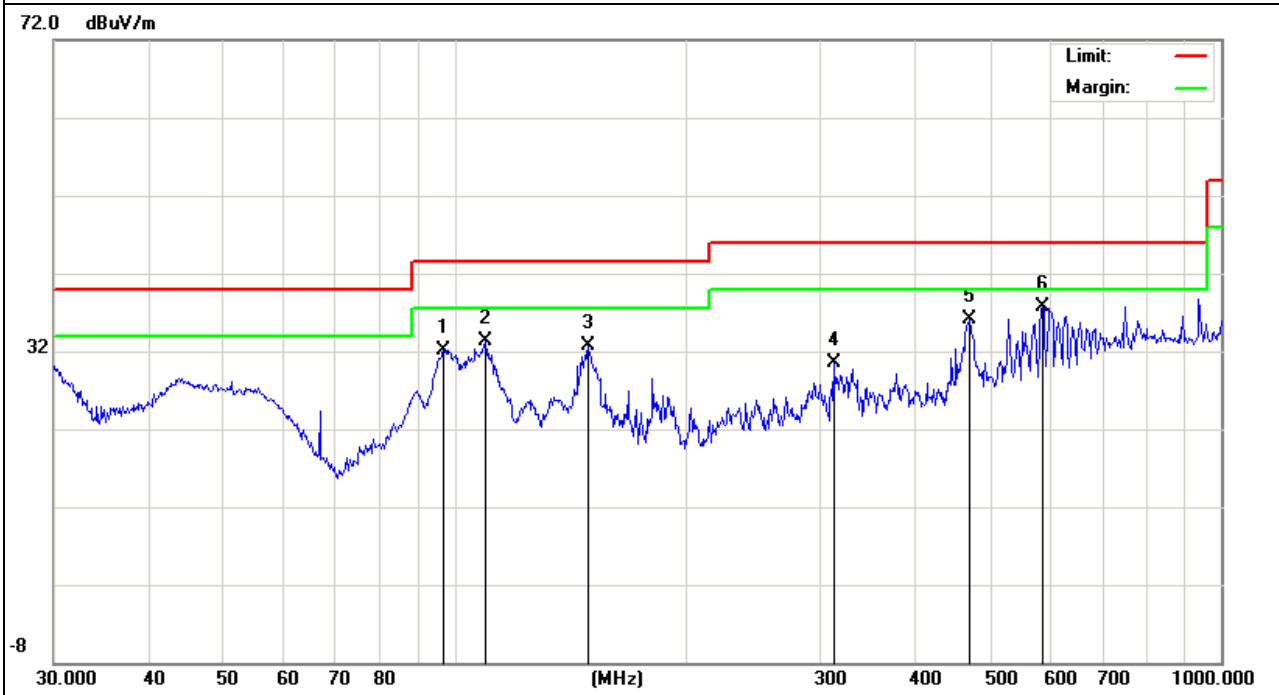

EUT :	2 in 1 tablet PC	Model Name :	JM101B
Temperature :	24 °C	Relative Humidity :	54%
Pressure :	1010 hPa	Test Date :	2015-08-13
Test Mode :	Mode 1- spindle keyboard	Polarization :	Horizontal
Test Power :	AC 120V/60Hz		

Freq. (MHz)	Reading (dBuV)	Factor (dBuV)	Measurement (dBuV)	Limit (dBuV)	Over (dB)	Remark
75.4462	17.28	5.72	23.00	40.00	-17.00	QP
98.1419	20.46	8.78	29.24	43.50	-14.26	QP
143.3257	16.08	11.07	27.15	43.50	-16.35	QP
250.3009	20.43	13.59	34.02	46.00	-11.98	QP
295.1469	20.26	14.10	34.36	46.00	-11.64	QP
545.1825	15.26	21.23	36.49	46.00	-9.51	QP

Remark:

Factor = Antenna Factor + Cable Loss - Amplifier.

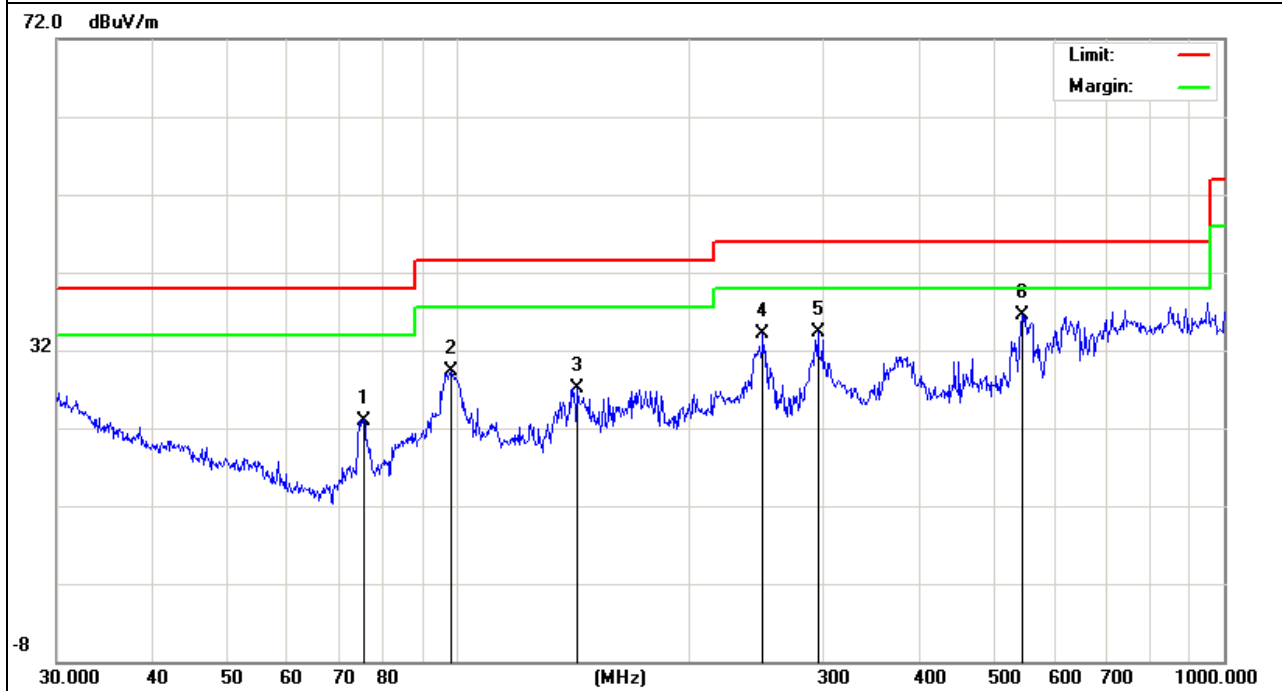

EUT :	2 in 1 tablet PC	Model Name :	JM101B
Temperature :	24 °C	Relative Humidity :	54%
Pressure :	1010 hPa	Test Date :	2015-08-13
Test Mode :	Mode 1-spindle keyboard	Polarization :	Vertical
Test Power :	AC 120V/60Hz		

Freq. (MHz)	Reading (dBuV)	Factor (dBuV)	Measurement (dBuV)	Limit (dBuV)	Over (dB)	Remark
31.0703	11.88	18.84	30.72	40.00	-9.28	QP
43.8119	16.58	12.31	28.89	40.00	-11.11	QP
96.7749	24.01	8.64	32.65	43.50	-10.85	QP
109.7960	22.47	9.93	32.40	43.50	-11.10	QP
168.4138	22.36	10.54	32.90	43.50	-10.60	QP
465.5994	17.04	19.61	36.65	46.00	-9.35	QP

Remark:
Factor = Antenna Factor + Cable Loss - Amplifier.

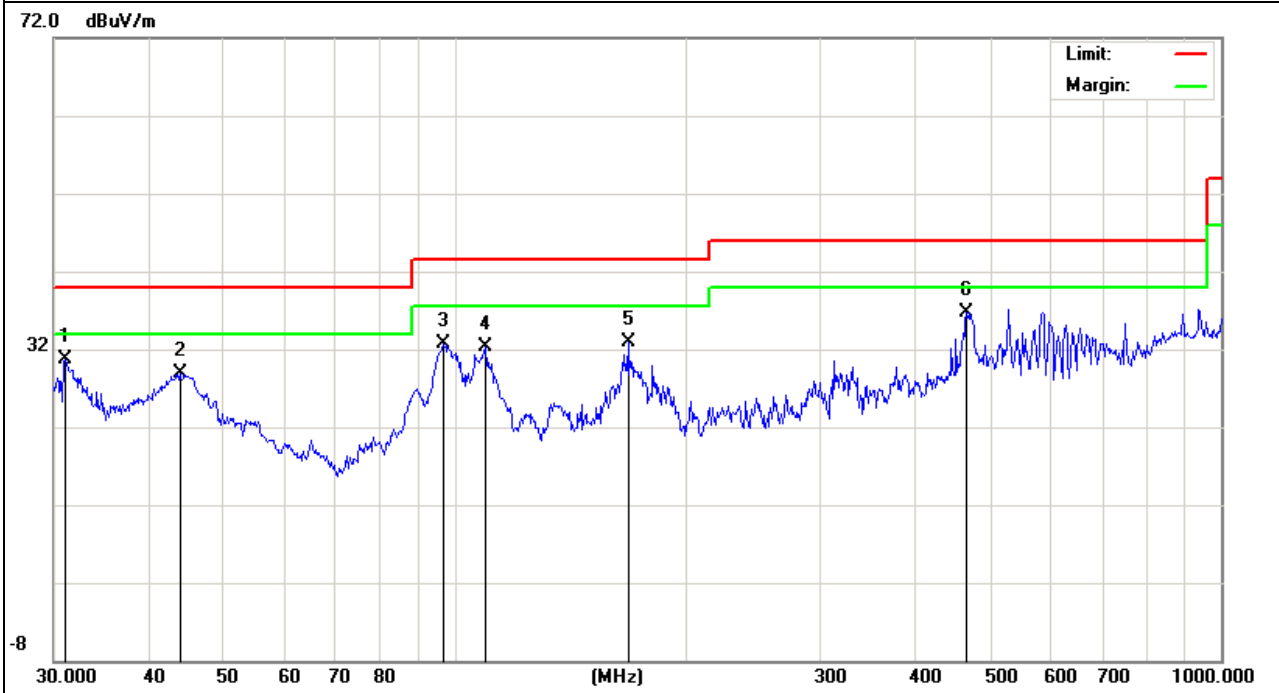

3.2.6 TEST RESULTS(1000~6000MHz)

Polar (H/V)	Frequency	Meter Reading	Factor	Emission Level	Limits	Margin	Remark
	(MHz)	(dBm)	(dB)	(dBm)	(dBm)	(dB)	
V	1499.209	62.98	-11.08	51.90	74.00	-22.10	peak
V	1499.209	50.66	-11.08	39.58	54.00	-14.42	AVG
V	1899.233	62.64	-9.24	53.40	74.00	-20.60	peak
V	1899.233	49.36	-9.24	40.12	54.00	-13.88	AVG
V	2284.166	60.81	-7.71	53.10	74.00	-20.90	peak
V	2284.166	49.07	-7.71	41.36	54.00	-12.64	AVG
H	1678.362	62.44	-10.34	52.10	74.00	-21.90	peak
H	1678.362	49.92	-10.34	39.58	54.00	-14.42	AVG
H	2000.527	62.47	-8.47	54.00	74.00	-20.00	peak
H	2000.527	49.73	-8.47	41.26	54.00	-12.74	AVG
H	2940.675	58.79	-6.49	52.30	74.00	-21.70	peak
H	2940.675	47.26	-6.49	40.77	54.00	-13.23	AVG

Remark:

Absolute Level= ReadingLevel+ Factor, Margin= Absolute Level - Limit

4. EUT TEST PHOTO

Radiated Measurement Photos

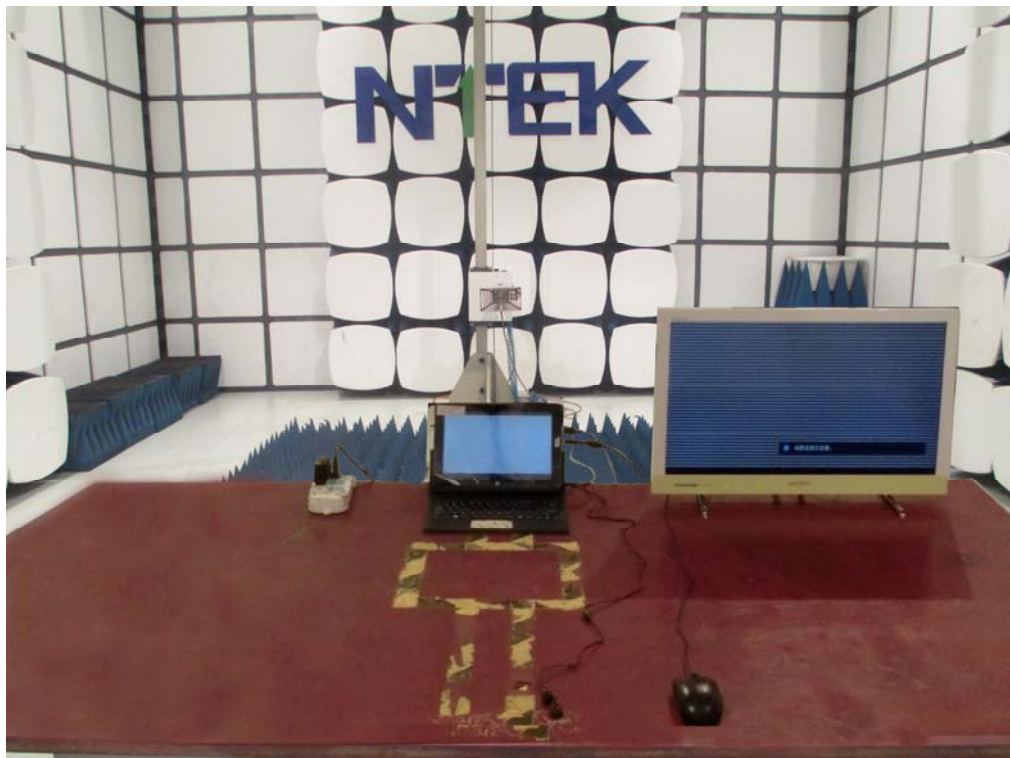
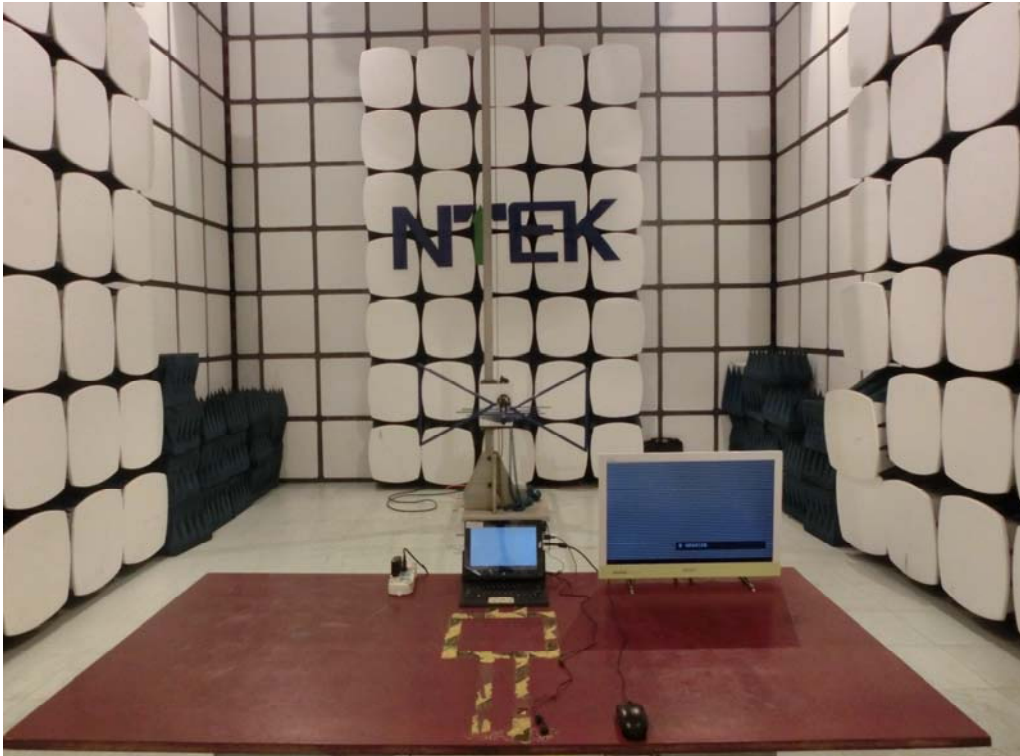

Conducted Measurement Photos

