



FCC RADIO TEST REPORT

FCC ID:2AFNZ-JM101XXX

Product : 2 in 1 tablet PC

Trade Name : N/A

Model Name : JM101B

Serial Model : JM101A00, JM101A01, JM101A10, JM101A11, JM101A21, JM101A40, JM101A41, JM101A50, JM101A51, JM101A61, JM101A, JM101B00, JM101B01, JM101B10, JM101B11, JM101B21, JM101B40, JM101B41, JM101B50, JM101B51, JM101B61, JM101X-YY (X: Range A~Z or blank, A indicate Folio type of keyboard; B indicate Hinge type of keyboard. And so on. Y: Range 00~99 or blank, indicate the difference in Product color , etc.)

Report No. : NTEK-2015NT06222095F4

Prepared for

JING MOLD ELECTRONICS TECHNOLOGY(SHENZHEN)CO.,LTD.

Xinqiao,3rd Industrial Estate,Shajing Baoan,Shenzhen,China

repared by

Shenzhen NTEK Testing Technology Co., Ltd.

1/F, Building E, Fenda Science Park, Sanwei Community, Xixiang Street
Bao'an District, Shenzhen P.R. China

Tel.: +86-0755-61156588 Fax.: +86-0755-61156599

Website:www.ntek.org.cn

TEST RESULT CERTIFICATION

Applicant's name JING MOLD ELECTRONICS TECHNOLOGY(SHENZHEN)CO.,LTD.

Address..... Xinqiao,3rd Industrial Estate,Shajing Baoan,Shenzhen,China

Manufacturer's Name ... JING MOLD ELECTRONICS TECHNOLOGY(SHENZHEN)CO.,LTD.

Address..... Xinqiao,3rd Industrial Estate,Shajing Baoan,Shenzhen,China

Product description

Product name..... 2 in 1 tablet PC

Model and/or type
reference JM101B

Serial Model Refer to Page 1

Standards FCC Part15.247 01 Oct. 2014

Test procedure ANSI C63.10-2013 and KDB 558074: June 5, 2014

This device described above has been tested by NTEK, and the test results show that the equipment under test (EUT) is in compliance with the FCC requirements. And it is applicable only to the tested sample identified in the report.

This report shall not be reproduced except in full, without the written approval of NTEK, this document may be altered or revised by NTEK, personnel only, and shall be noted in the revision of the document.

Date of Test

Date (s) of performance of tests..... 22 Jun.2015~20 Aug.2015

Date of Issue 20 Aug.2015

Test Result..... **Pass**

Testing Engineer :



(Allen Liu)

Technical Manager :

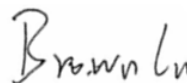

(Brown Lu)

Authorized Signatory :

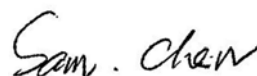

(Sam Chen)

Table of Contents

	Page
1 . SUMMARY OF TEST RESULTS	5
1.1 TEST FACILITY	6
1.2 MEASUREMENT UNCERTAINTY	6
2 . GENERAL INFORMATION	7
2.1 GENERAL DESCRIPTION OF EUT	7
2.2 DESCRIPTION OF TEST MODES	9
2.3 BLOCK DIGRAM SHOWING THE CONFIGURATION OF SYSTEM TESTED	10
2.4 DESCRIPTION OF SUPPORT UNITS(CONDUCTED MODE)	11
2.5 EQUIPMENTS LIST FOR ALL TEST ITEMS	12
3 . EMC EMISSION TEST	14
3.1 CONDUCTED EMISSION MEASUREMENT	14
3.1.1 POWER LINE CONDUCTED EMISSION LIMITS	14
3.1.2 TEST PROCEDURE	15
3.1.3 DEVIATION FROM TEST STANDARD	15
3.1.4 TEST SETUP	15
3.1.5 EUT OPERATING CONDITIONS	15
3.1.6 TEST RESULTS	16
3.2 RADIATED EMISSION MEASUREMENT	20
3.2.1 RADIATED EMISSION LIMITS	20
3.2.2 TEST PROCEDURE	21
3.2.3 DEVIATION FROM TEST STANDARD	21
3.2.4 TEST SETUP	22
3.2.5 EUT OPERATING CONDITIONS	23
3.2.6 TEST RESULTS (BETWEEN 9KHZ – 30 MHZ)	24
3.2.7 TEST RESULTS (BETWEEN 30MHZ – 1GHZ)	25
3.2.8 TEST RESULTS (ABOVE 1000 MHZ)	27
4 . POWER SPECTRAL DENSITY TEST	28
4.1 APPLIED PROCEDURES / LIMIT	28
4.1.1 TEST PROCEDURE	28
4.1.2 DEVIATION FROM STANDARD	28
4.1.3 TEST SETUP	28
4.1.4 EUT OPERATION CONDITIONS	28
4.1.5 TEST RESULTS	29
5 . BANDWIDTH TEST	37
5.1 APPLIED PROCEDURES / LIMIT	37
5.1.1 TEST PROCEDURE	37

Table of Contents

	Page
TEST SETUP	37
5.1.2 EUT OPERATION CONDITIONS	37
5.1.3 TEST RESULTS	38
6 . PEAK OUTPUT POWER TEST	46
6.1 APPLIED PROCEDURES / LIMIT	46
6.1.1 TEST PROCEDURE	46
6.1.2 DEVIATION FROM STANDARD	46
6.1.3 TEST SETUP	46
6.1.4 EUT OPERATION CONDITIONS	46
6.1.5 TEST RESULTS	47
7 . 100 KHZ BANDWIDTH OF FREQUENCY BAND EDGE	48
7.1 DEVIATION FROM STANDARD	48
7.2 TEST SETUP	48
7.3 EUT OPERATION CONDITIONS	48
7.4 TEST RESULTS	49
8 . ANTENNA REQUIREMENT	55
8.1 STANDARD REQUIREMENT	55
8.2 EUT ANTENNA	55
9 . EUT TEST PHOTO	56
APPENDIX-PHOTOGRAPHS OF EUT CONSTRUCTIONAL DETAILS	

1. SUMMARY OF TEST RESULTS

Test procedures according to the technical standards:

FCC Part15 (15.247) , Subpart C			
Standard Section	Test Item	Judgment	Remark
15.207	Conducted Emission	PASS	
15.247 (a)(2)	6dB Bandwidth	PASS	
15.247 (b)	Peak Output Power	PASS	
15.247 (c)	Radiated Spurious Emission	PASS	
15.247 (d)	Power Spectral Density	PASS	
15.205	Band Edge Emission	PASS	
15.203	Antenna Requirement	PASS	

NOTE:

(1) "N/A" denotes test is not applicable in this Test Report

1.1 TEST FACILITY

NTEK Testing Technology Co., Ltd
 Add.:1/F, Building E, Fenda Science Park, Sanwei Community, Xixiang Street, Bao'an District, Shenzhen P.R. China.
 FCC Registration No.:238937; IC Registration No.:9270A-1
 CNAS Registration No.:L5516

1.2 MEASUREMENT UNCERTAINTY

The reported uncertainty of measurement $y \pm U$, where expanded uncertainty U is based on a standard uncertainty multiplied by a coverage factor of $k=2$, providing a level of confidence of approximately 95 %.

No.	Item	Uncertainty
1	Conducted Emission Test	$\pm 1.38\text{dB}$
2	RF power,conducted	$\pm 0.16\text{dB}$
3	Spurious emissions,conducted	$\pm 0.21\text{dB}$
4	All emissions,radiated(<1G)	$\pm 4.68\text{dB}$
5	All emissions,radiated(>1G)	$\pm 4.89\text{dB}$
6	Temperature	$\pm 0.5^\circ\text{C}$
7	Humidity	$\pm 2\%$

2. GENERAL INFORMATION

2.1 GENERAL DESCRIPTION OF EUT

Equipment	2 in 1 tablet PC	
Trade Name	N/A	
Model Name	JM101B	
Serial Model	Refer to Page 1	
Model Difference	All models used the same PCBA board, the difference is only in the collocation keyboard type, product color ,etc.	
Product Description	Operation Frequency:	802.11b/g/n(20MHz): 2412~2462MHz 802.11n(40MHz):2422~2452MHz
	Modulation Type:	IEEE 802.11b : DSSS (CCK, QPSK, DBPSK) IEEE 802.11g/n (HT20/HT40) : OFDM(64QAM, 16QAM, QPSK, BPSK)
	Bit Rate of Transmitter	802.11b:11/5.5/2/1 Mbps 802.11g:54/48/36/24/18/12/9/6Mbps 802.11n(20MHz/40MHz):150/144.44/130/117/115.56/104/86.67/78/52/6.5Mbps
	Number Of Channel	802.11b/g/n20MHz:11CH 802.11n40MHz:7CH
	Antenna Designation:	Please see Note 3.
	Antenna Gain (dBi)	1.0 dBi
Channel List	Please refer to the Note 2.	
Ratings	DC 3.8V	
Adapter	Mode : F12US0500200A Input: 100-240V~, 50/60Hz, 0.5A Max Output: 5V---, 2.0A	
Battery	DC 3.8V, 7400mAh	
Connecting I/O Port(s)	Please refer to the User's Manual	

Note:

1. For a more detailed features description, please refer to the manufacturer's specifications or the User's Manual.

2.

Channel List for 802.11b/g/n(20 MHz)							
Channel	Frequency (MHz)	Channel	Frequency (MHz)	Channel	Frequency (MHz)	Channel	Frequency (MHz)
01	2412	04	2427	07	2442	10	2457
02	2417	05	2432	08	2447	11	2462
03	2422	06	2437	09	2452		

Channel List for 802.11n(40MHz)							
Channel	Frequency (MHz)	Channel	Frequency (MHz)	Channel	Frequency (MHz)	Channel	Frequency (MHz)
03	2422	06	2437	09	2452		
04	2427	07	2442				
05	2432	08	2447				

3.

Table for Filed Antenna

Ant	Brand	Model Name	Antenna Type	Connector	Gain (dBi)	NOTE
A	N/A	N/A	FPCB Antenna	N/A	1.0	Wifi Antenna

2.2 DESCRIPTION OF TEST MODES

To investigate the maximum EMI emission characteristics generates from EUT, the test system was pre-scanning tested base on the consideration of following EUT operation mode or test configuration mode which possible have effect on EMI emission level. Each of these EUT operation mode(s) or test configuration mode(s) mentioned above was evaluated respectively.

Pretest Mode	Description
Mode 1	802.11b CH1/ CH6/ CH11
Mode 2	802.11g CH1/ CH6/ CH11
Mode 3	802.11n20 CH1/ CH6/ CH11
Mode 4	802.11n40 CH3/ CH6/ CH9
Mode 5	Link Mode

For Conducted Emission	
Final Test Mode	Description
Mode 5	Link Mode

For Radiated Emission	
Final Test Mode	Description
Mode 1	802.11b CH1/ CH6/ CH11
Mode 2	802.11g CH1/ CH6/ CH11
Mode 3	802.11n20 CH1/ CH6/ CH11
Mode 4	802.11n40 CH3/ CH6/ CH 9
Mode 5	Link Mode

Note:

- (1) The measurements are performed at the highest, middle, lowest available channels.
- (2) The measurements are performed at all Bit Rate of Transmitter, the worst data was reported
- (3) EUT configured to transmit continuously:

Operated Mode for Worst Duty Cycle	
Test Signal Duty Cycle (x)	Average correction factor (dB)
100% - IEEE 802.11b	0
100% - IEEE 802.11g	0
100% - IEEE 802.11n (HT20)	0
100% - IEEE 802.11n (HT40)	0

2.3 BLOCK DIGRAM SHOWING THE CONFIGURATION OF SYSTEM TESTED

Conducted Emission Test

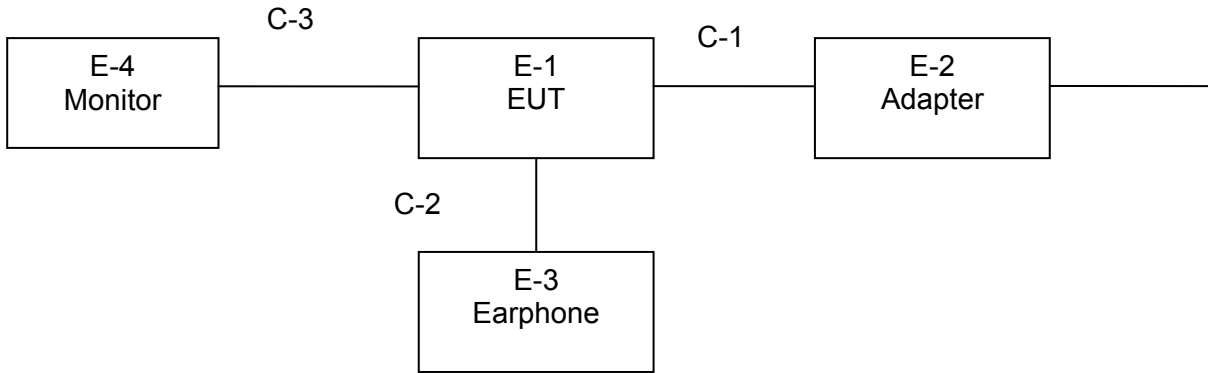

Radiated Spurious Emission Test

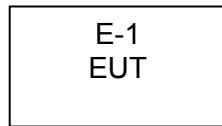

2.4 DESCRIPTION OF SUPPORT UNITS(CONDUCTED MODE)

The EUT has been tested as an independent unit together with other necessary accessories or support units. The following support units or accessories were used to form a representative test configuration during the tests.

Item	Equipment	Brand	Model/Type No.	Series No.	Note
E-1	2 in 1 tablet PC	N/A	JM101B	N/A	EUT
E-2	Adapter	N/A	F12US0500200A	N/A	
E-3	Earphone	N/A	2688	N/A	
E-4	Monitor	SONY	KDL-24EX520	6450750	

Item	Shielded Type	Ferrite Core	Length	Note
C-1	NO	NO	1.2m	
C-2	NO	NO	1.0m	
C-3	NO	NO	1.0m	

Note:

- (1) The support equipment was authorized by Declaration of Confirmation.
- (2) For detachable type I/O cable should be specified the length in cm in 『Length』 column.

2.5 EQUIPMENTS LIST FOR ALL TEST ITEMS

Radiation Test equipment

Item	Kind of Equipment	Manufacturer	Type No.	Serial No.	Last calibration	Calibrated until	Calibration period
1	Spectrum Analyzer	Agilent	E4407B	MY45108040	2015.07.06	2016.07.05	1 year
2	Test Receiver	R&S	ESPI	101318	2015.06.06	2016.06.05	1 year
3	Bilog Antenna	TESEQ	CBL6111D	31216	2015.07.06	2016.07.05	1 year
4	50Ω Coaxial Switch	Anritsu	MP59B	6200264416	2015.06.06	2016.06.05	1 year
5	Spectrum Analyzer	ADVANTEST	R3132	150900201	2015.06.06	2016.06.05	1 year
6	Horn Antenna	EM	EM-AH-10180	2011071402	2015.07.06	2016.07.05	1 year
7	Horn Ant	Schwarzbeck	BBHA 9170	9170-181	2015.07.06	2016.07.05	1 year
8	Amplifier	EM	EM-30180	060538	2014.12.22	2015.12.21	1 year
9	Loop Antenna	ARA	PLA-1030/B	1029	2015.06.06	2016.06.05	1 year
10	Power Meter	R&S	NRVS	100696	2015.07.06	2016.07.05	1 year
11	Power Sensor	R&S	URV5-Z4	0395.1619.05	2015.07.06	2016.07.05	1 year

Item	Kind of Equipment	Manufacturer	Type No.	Serial No.	Last calibration	Calibrated until	Calibration period
1	Spectrum Analyzer	Agilent	E4407B	MY45108040	2014.07.06	2015.07.05	1 year
3	Bilog Antenna	TESEQ	CBL6111D	31216	2014.07.06	2015.07.05	1 year
6	Horn Antenna	EM	EM-AH-10180	2011071402	2014.07.06	2015.07.05	1 year
7	Horn Ant	Schwarzbeck	BBHA 9170	9170-181	2014.07.06	2015.07.05	1 year
10	Power Meter	R&S	NRVS	100696	2014.07.06	2015.07.05	1 year
11	Power Sensor	R&S	URV5-Z4	0395.1619.05	2014.07.06	2015.07.05	1 year

Conduction Test equipment

Item	Kind of Equipment	Manufacturer	Type No.	Serial No.	Last calibration	Calibrated until	Calibration period
1	Test Receiver	R&S	ESCI	101160	2015.06.06	2016.06.05	1 year
2	LISN	R&S	ENV216	101313	2014.08.24	2015.08.23	1 year
3	LISN	EMCO	3816/2	00042990	2014.08.24	2015.08.23	1 year
4	50Ω Coaxial Switch	Anritsu	MP59B	6200264417	2015.06.06	2016.06.05	1 year
5	Passive Voltage Probe	R&S	ESH2-Z3	100196	2015.06.06	2016.06.05	1 year
6	Absorbing clamp	R&S	MOS-21	100423	2015.06.06	2016.06.05	1 year

1	Attenuation	MCE	24-10-34	BN9258	2015.06.06	2016.06.05	1 year
---	-------------	-----	----------	--------	------------	------------	--------

3. EMC EMISSION TEST

3.1 CONDUCTED EMISSION MEASUREMENT

3.1.1 POWER LINE CONDUCTED EMISSION Limits (Frequency Range 150KHz-30MHz)

FREQUENCY (MHz)	Class A (dBuV)		Class B (dBuV)		Standard
	Quasi-peak	Average	Quasi-peak	Average	
0.15 -0.5	79.00	66.00	66 - 56 *	56 - 46 *	CISPR
0.50 -5.0	73.00	60.00	56.00	46.00	CISPR
5.0 -30.0	73.00	60.00	60.00	50.00	CISPR

0.15 -0.5	79.00	66.00	66 - 56 *	56 - 46 *	FCC
0.50 -5.0	73.00	60.00	56.00	46.00	FCC
5.0 -30.0	73.00	60.00	60.00	50.00	FCC

Note:

- (1) The tighter limit applies at the band edges.
- (2) The limit of " * " marked band means the limitation decreases linearly with the logarithm of the frequency in the range.

The following table is the setting of the receiver

Receiver Parameters	Setting
Attenuation	10 dB
Start Frequency	0.15 MHz
Stop Frequency	30 MHz
IF Bandwidth	9 kHz

3.1.2 TEST PROCEDURE

- a. The EUT was placed 0.8 meters from the horizontal ground plane with EUT being connected to the power mains through a line impedance stabilization network (LISN). All other support equipments powered from additional LISN(s). The LISN provide 50 Ohm/ 50uH of coupling impedance for the measuring instrument.
- b. Interconnecting cables that hang closer than 40 cm to the ground plane shall be folded back and forth in the center forming a bundle 30 to 40 cm long.
- c. I/O cables that are not connected to a peripheral shall be bundled in the center. The end of the cable may be terminated, if required, using the correct terminating impedance. The overall length shall not exceed 1 m.
- d. LISN at least 80 cm from nearest part of EUT chassis.
- e. For the actual test configuration, please refer to the related Item –EUT Test Photos.

3.1.3 DEVIATION FROM TEST STANDARD

No deviation

3.1.4 TEST SETUP

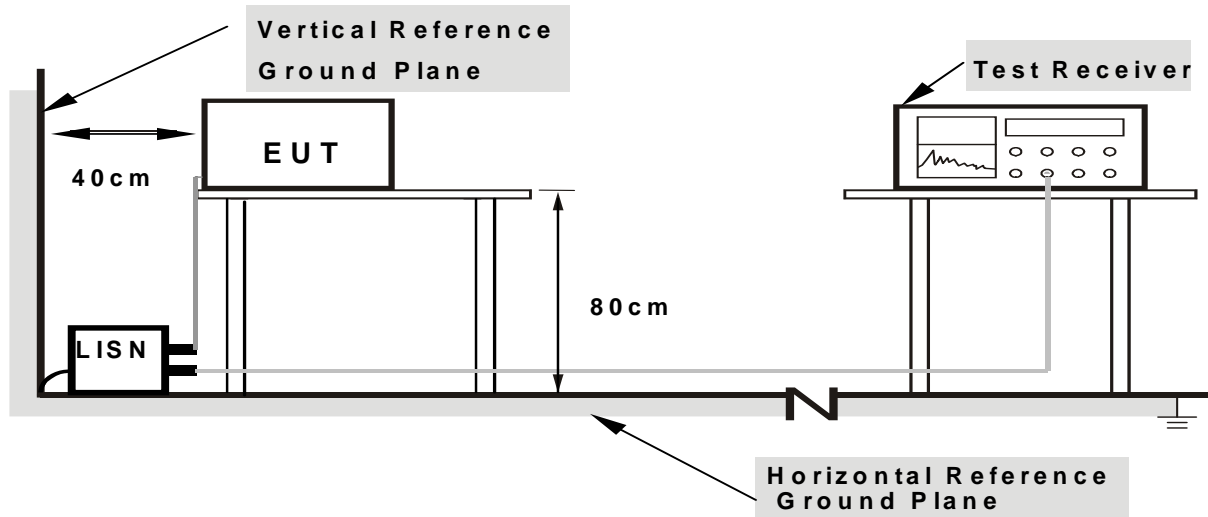

- Note:**
- 1. Support units were connected to second LISN.
 - 2. Both of LISNs (AMN) are 80 cm from EUT and at least 80 from other units and other metal planes

3.1.5 EUT OPERATING CONDITIONS

The EUT was configured for testing in a typical fashion (as a customer would normally use it). The EUT has been programmed to continuously transmit during test. This operating condition was tested and used to collect the included data.

3.1.6 TEST RESULTS

EUT :	2 in 1 tablet PC	Model Name. :	JM101B
Temperature :	26 °C	Relative Humidity :	56%
Pressure :	1010hPa	Phase :	L
Test Voltage :	DC 5.0V From adapter AC120V/60Hz	Test Mode :	Mode 5

Frequency (MHz)	Meter Reading (dBμV)	Factor (dB)	Emission Level (dBμV)	Limits (dBμV)	Margin (dB)	Remark
0.1780	43.63	9.62	53.25	64.57	-11.32	QP
0.1780	29.58	9.62	39.20	54.57	-15.37	AVG
0.3260	36.97	9.64	46.61	59.55	-12.94	QP
0.3260	24.34	9.64	33.98	49.55	-15.57	AVG
0.5580	40.65	9.78	50.43	56.00	-5.57	QP
0.5580	28.90	9.78	38.68	46.00	-7.32	AVG
0.8580	38.76	9.75	48.51	56.00	-7.49	QP
0.8580	25.34	9.75	35.09	46.00	-10.91	AVG
1.3220	36.29	9.71	46.00	56.00	-10.00	QP
1.3220	21.56	9.71	31.27	46.00	-14.73	AVG
21.2979	40.62	9.96	50.58	60.00	-9.42	QP
21.2979	29.17	9.96	39.13	50.00	-10.87	AVG

Remark:

1. All readings are Quasi-Peak and Average values.
2. Factor = Insertion Loss + Cable Loss.

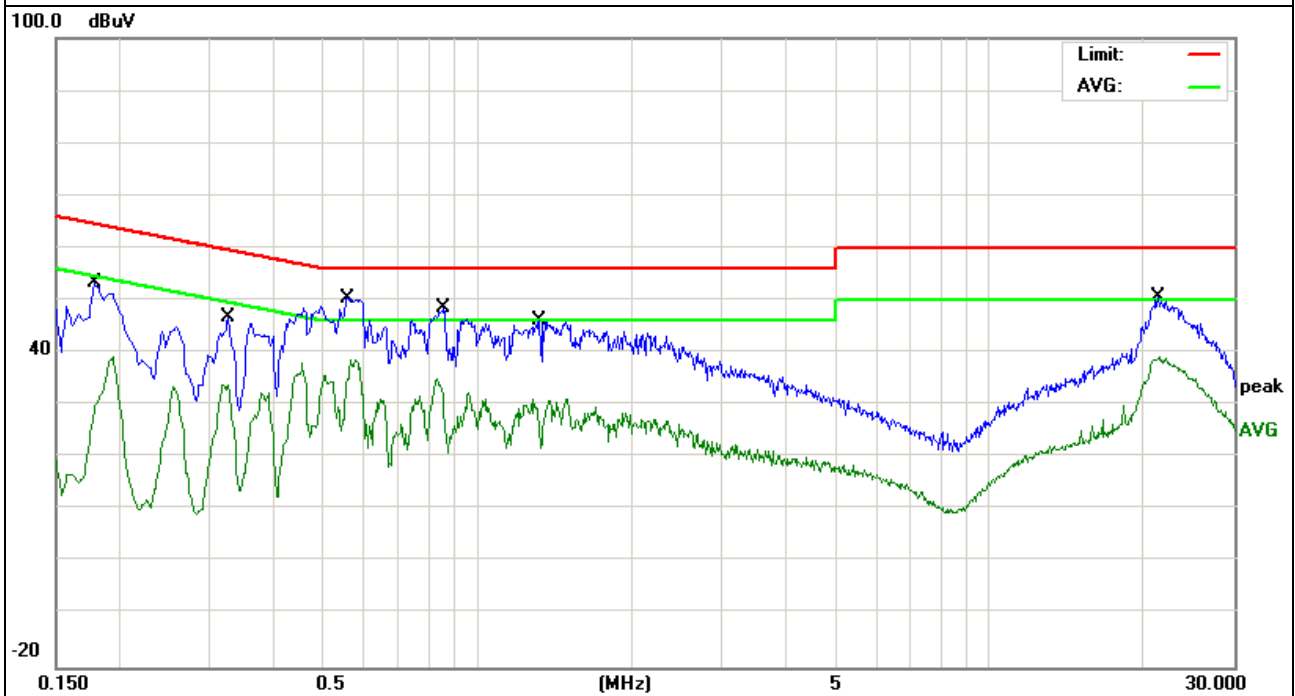

EUT :	2 in 1 tablet PC	Model Name. :	JM101B
Temperature :	26 °C	Relative Humidity :	56%
Pressure :	1010hPa	Phase :	N
Test Voltage :	DC 5.0V From adapter AC120V/60Hz	Test Mode :	Mode 5

Frequency (MHz)	Meter Reading (dBμV)	Factor (dB)	Emission Level (dBμV)	Limits (dBμV)	Margin (dB)	Remark
0.1900	41.39	9.61	51.00	64.03	-13.03	QP
0.1900	27.91	9.61	37.52	54.03	-16.51	AVG
0.4580	38.00	9.66	47.66	56.73	-9.07	QP
0.4580	27.17	9.66	36.83	46.73	-9.90	AVG
0.5580	40.26	9.67	49.93	56.00	-6.07	QP
0.5580	29.19	9.67	38.86	46.00	-7.14	AVG
0.8500	37.79	9.62	47.41	56.00	-8.59	QP
0.8500	23.93	9.62	33.55	46.00	-12.45	AVG
1.4980	36.40	9.58	45.98	56.00	-10.02	QP
1.4980	20.70	9.58	30.28	46.00	-15.72	AVG
21.7740	41.48	9.87	51.35	60.00	-8.65	QP
21.7740	31.31	9.87	41.18	50.00	-8.82	AVG

Remark:

1. All readings are Quasi-Peak and Average values.
2. Factor = Insertion Loss + Cable Loss.

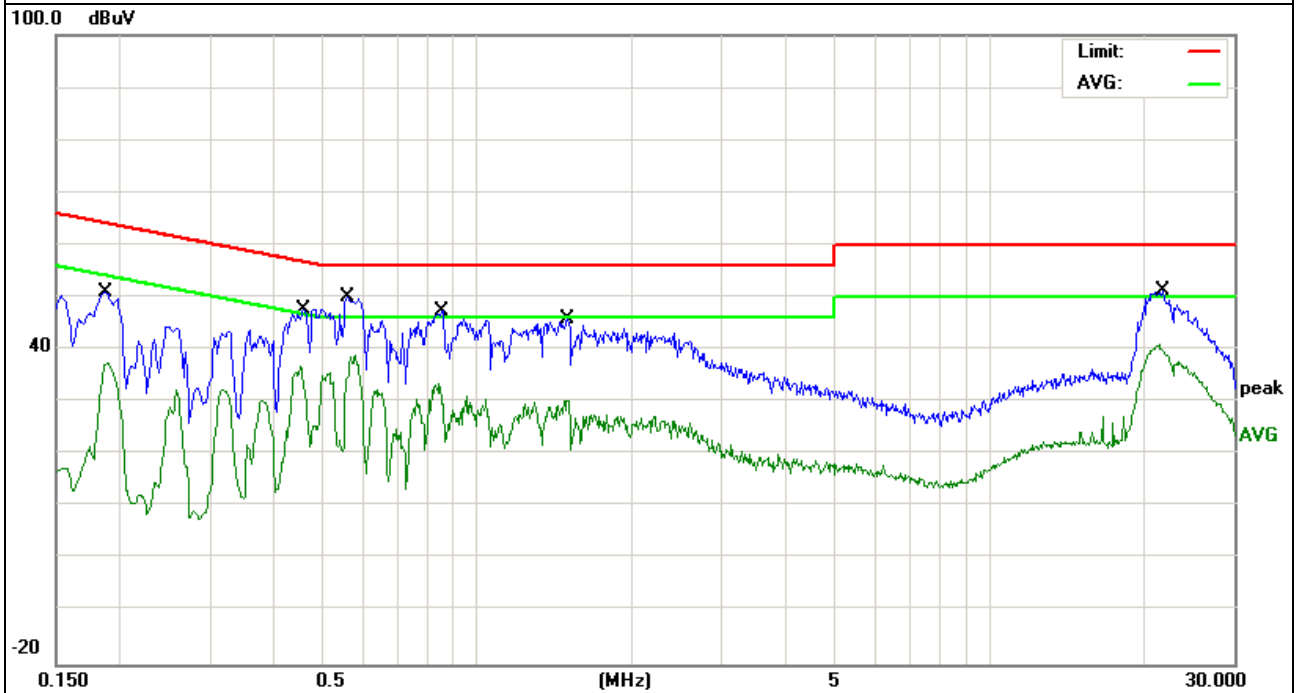

EUT :	2 in 1 tablet PC	Model Name. :	JM101B
Temperature :	26 °C	Relative Humidity :	56%
Pressure :	1010hPa	Phase :	L
Test Voltage :	DC 5.0V From adapter AC 240V/60Hz	Test Mode :	Mode 5

Frequency (MHz)	Meter Reading (dBμV)	Factor (dB)	Emission Level (dBμV)	Limits (dBμV)	Margin (dB)	Remark
0.1580	38.51	9.62	48.13	65.56	-17.43	QP
0.1580	20.68	9.62	30.30	55.56	-25.26	AVG
0.5780	39.67	9.77	49.44	56.00	-6.56	QP
0.5780	29.69	9.77	39.46	46.00	-6.54	AVG
0.9700	30.71	9.73	40.44	56.00	-15.56	QP
0.9700	20.03	9.73	29.76	46.00	-16.24	AVG
1.1180	30.53	9.72	40.25	56.00	-15.75	QP
1.1180	19.03	9.72	28.75	46.00	-17.25	AVG
1.8700	28.45	9.66	38.11	56.00	-17.89	QP
1.8700	16.92	9.66	26.58	46.00	-19.42	AVG
20.8420	30.84	9.96	40.80	60.00	-19.20	QP
20.8420	21.74	9.96	31.70	50.00	-18.30	AVG

Remark:

1. All readings are Quasi-Peak and Average values.
2. Factor = Insertion Loss + Cable Loss.

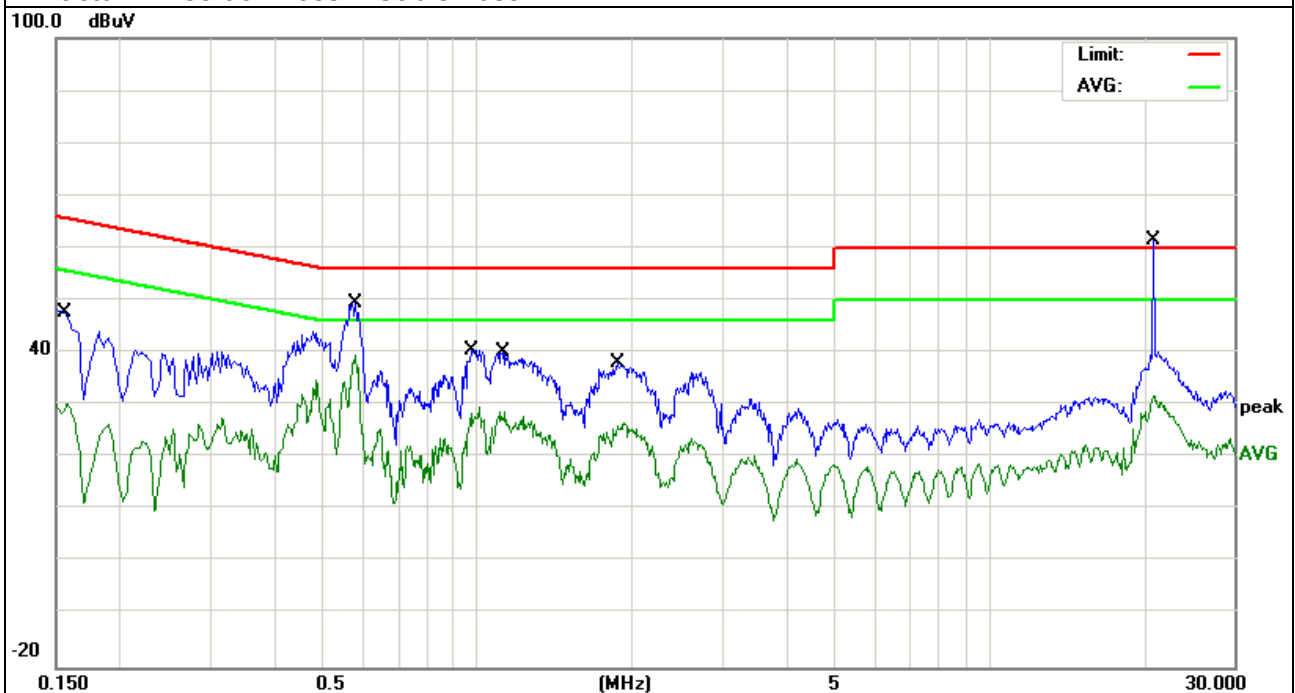

EUT :	2 in 1 tablet PC	Model Name. :	JM101B
Temperature :	26 °C	Relative Humidity :	56%
Pressure :	1010hPa	Phase :	N
Test Voltage :	DC 5.0V From adapter AC240V/60Hz	Test Mode :	Mode 5

Frequency (MHz)	Meter Reading (dBμV)	Factor (dB)	Emission Level (dBμV)	Limits (dBμV)	Margin (dB)	Remark
0.1539	38.80	9.60	48.40	65.78	-17.38	QP
0.1539	20.46	9.60	30.06	55.78	-25.72	AVG
0.4660	33.76	9.66	43.42	56.58	-13.16	QP
0.4660	22.53	9.66	32.19	46.58	-14.39	AVG
0.5660	39.41	9.67	49.08	56.00	-6.92	QP
0.5660	28.62	9.67	38.29	46.00	-7.71	AVG
0.9900	31.66	9.61	41.27	56.00	-14.73	QP
0.9900	19.73	9.61	29.34	46.00	-16.66	AVG
1.0820	31.76	9.60	41.36	56.00	-14.64	QP
1.0820	20.33	9.60	29.93	46.00	-16.07	AVG
1.8700	28.10	9.55	37.65	56.00	-18.35	QP
1.8700	16.85	9.55	26.40	46.00	-19.60	AVG

Remark:

1. All readings are Quasi-Peak and Average values.
2. Factor = Insertion Loss + Cable Loss.



3.2 RADIATED EMISSION MEASUREMENT

3.2.1 RADIATED EMISSION LIMITS (Frequency Range 9kHz-1000MHz)

20dBc in any 100 kHz bandwidth outside the operating frequency band. In case the emission fall within the restricted band specified on 15.205(a), then the 15.209(a) limit in the table below has to be followed.

Frequencies (MHz)	Field Strength (microrvolts/meter)	Measurement Distance (meters)
0.009~0.490	2400/F(KHz)	300
0.490~1.705	24000/F(KHz)	30
1.705~30.0	30	30
30~88	100	3
88~216	150	3
216~960	200	3
Above 960	500	3

LIMITS OF RADIATED EMISSION MEASUREMENT (Above 1000MHz)

FREQUENCY (MHz)	dBuV/m@at 3M	
	PEAK	AVERAGE
Above 1000	74	54

Notes:

- (1) The limit for radiated test was performed according to FCC PART 15C.
- (2) The tighter limit applies at the band edges.
- (3) Emission level (dBuV/m)=20log Emission level (uV/m).

Spectrum Parameter	Setting
Attenuation	Auto
Start Frequency	1000 MHz
Stop Frequency	10th carrier harmonic
RB / VB (emission in restricted band)	1 MHz / 1 MHz for Peak, 1 MHz / 10Hz for Average

Receiver Parameter	Setting
Attenuation	Auto
Start ~ Stop Frequency	9kHz~150kHz / RB 200Hz for QP
Start ~ Stop Frequency	150kHz~30MHz / RB 9kHz for QP
Start ~ Stop Frequency	30MHz~1000MHz / RB 120kHz for QP

3.2.2 TEST PROCEDURE

- a. The measuring distance of at 3 m shall be used for measurements at frequency up to 1GHz. For frequencies above 1GHz, any suitable measuring distance may be used.
- b. The EUT was placed on the top of a rotating table 0.8 m for below 1GHz and 1.5m for above 1GHz the ground at a 3 meter open area test site. The table was rotated 360 degrees to determine the position of the highest radiation.
- c. The height of the equipment or of the substitution antenna shall be 0.8 m for below 1GHz and 1.5m for above 1GHz; the height of the test antenna shall vary between 1 m to 4 m. Both horizontal and vertical polarizations of the antenna are set to make the measurement.
- d. The initial step in collecting conducted emission data is a spectrum analyzer peak detector mode pre-scanning the measurement frequency range. Significant peaks are then marked and then Quasi Peak detector mode re-measured.
- e. If the Peak Mode measured value compliance with and lower than Quasi Peak Mode Limit, the EUT shall be deemed to meet QP Limits and then no additional QP Mode measurement performed.
- f. For the actual test configuration, please refer to the related Item –EUT Test Photos.

Note:

Both horizontal and vertical antenna polarities were tested and performed pretest to three orthogonal axis. The worst case emissions were reported

During the radiated emission test, the Spectrum Analyzer was set with the following configurations:

Frequency Band (MHz)	Function	Resolution bandwidth	Video Bandwidth
30 to 1000	Peak	100 kHz	100 kHz
Above 1000	Peak	1 MHz	1 MHz
	Average	1 MHz	10 Hz

3.2.3 DEVIATION FROM TEST STANDARD

No deviation

3.2.4 TEST SETUP

(A) Radiated Emission Test-Up Frequency Below 30MHz

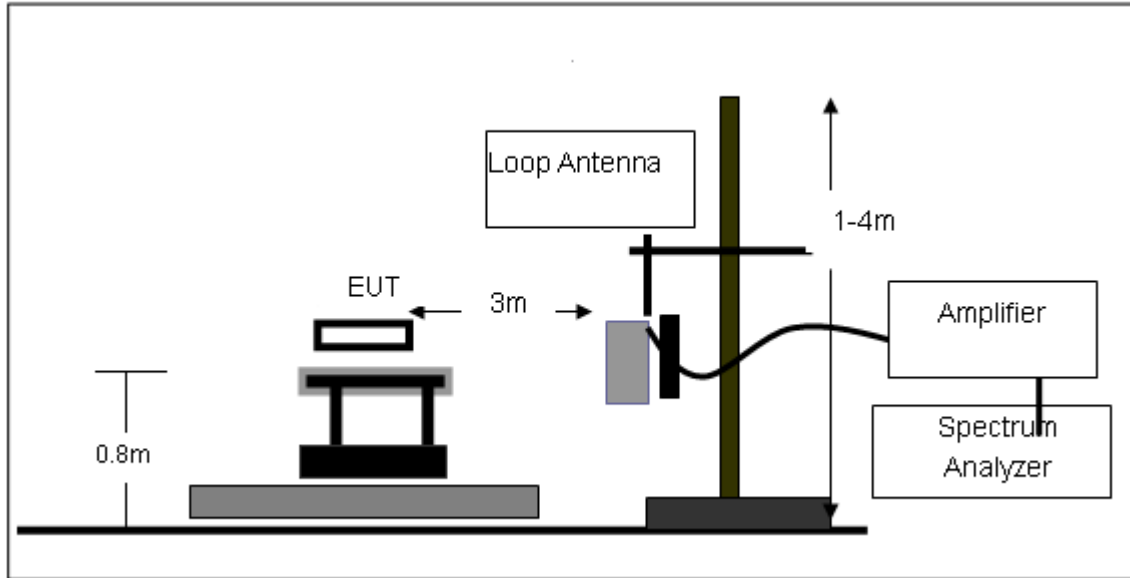

(B) Radiated Emission Test-Up Frequency 30MHz~1GHz

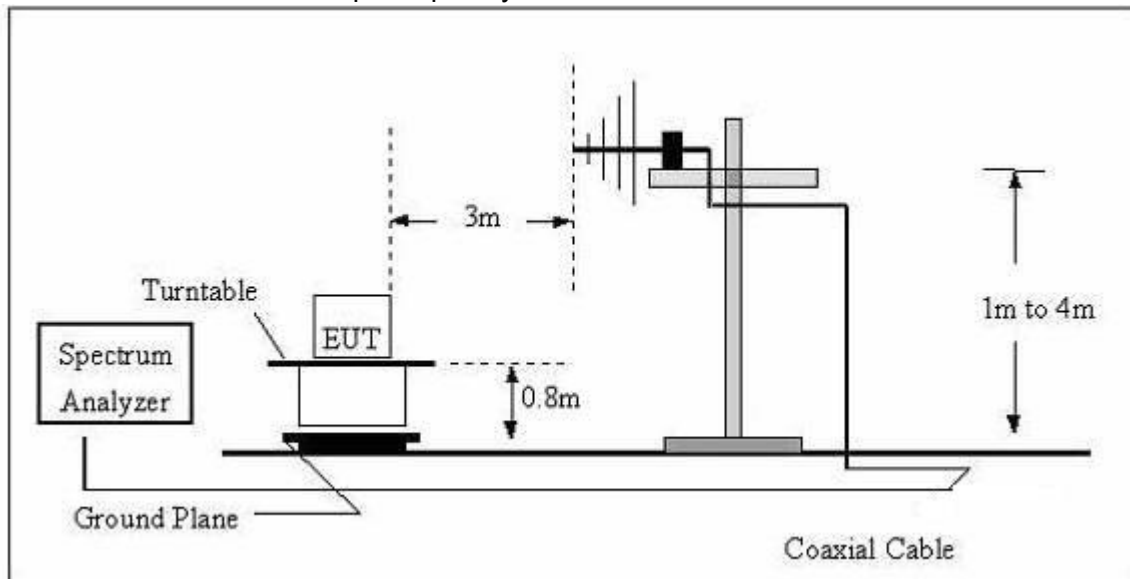

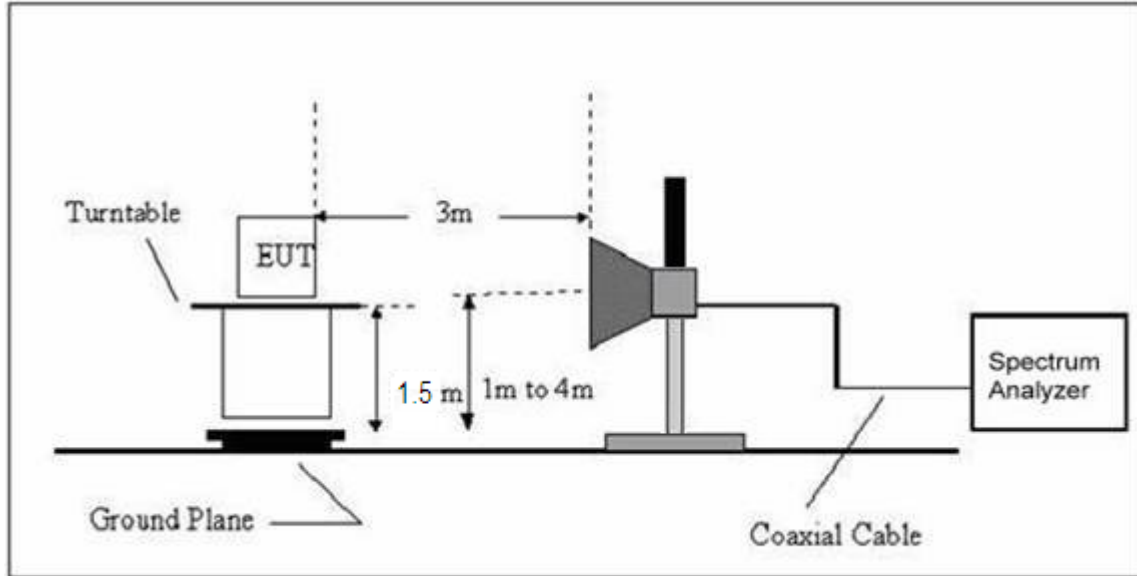
(C) Radiated Emission Test-Up Frequency Above 1GHz**3.2.5 EUT OPERATING CONDITIONS**

The EUT tested system was configured as the statements of 2.4 Unless otherwise a special operating condition is specified in the follows during the testing.

3.2.6 TEST RESULTS (BETWEEN 9KHZ – 30 MHZ)

EUT:	2 in 1 tablet PC	Model Name. :	JM101B
Temperature:	20 °C	Relative Humidity:	48%
Pressure:	1010 hPa	Test Voltage :	DC 3.8V
Test Mode :	TX	Polarization :	--

Freq. (MHz)	Reading (dBuV/m)	Limit (dBuV/m)	Margin (dB)	State P/F
--	--	--	--	N/A
--	--	--	--	N/A

NOTE:

The amplitude of spurious emissions which are attenuated by more than 20dB below the permissible value has no need to be reported.

Distance extrapolation factor = $40 \log (\text{specific distance}/\text{test distance})$ (dB);

Limit line = specific limits(dBuv) + distance extrapolation factor.

3.2.7 TEST RESULTS (BETWEEN 30MHZ – 1GHZ)

EUT :	2 in 1 tablet PC	Model Name :	JM101B
Temperature :	20 °C	Relative Humidity :	48%
Pressure :	1010 hPa	Test Voltage :	DC 3.8V
Test Mode :	TX		

Polar (H/V)	Frequency	Meter Reading	Factor	Emission Level	Limits	Margin	Remark
	(MHz)	(dBuV)	(dB)	(dBuV/m)	(dBuV/m)	(dB)	
V	48.3318	25.54	11.11	36.65	40.00	-3.35	QP
V	59.4405	27.98	7.99	35.97	40.00	-4.03	QP
V	116.9495	25.82	11.44	37.26	43.50	-6.24	QP
V	155.9101	26.95	10.45	37.40	43.50	-6.10	QP
V	203.5226	24.54	11.02	35.56	43.50	-7.94	QP
V	545.1825	11.78	21.23	33.01	46.00	-12.99	QP

Remark:

Absolute Level= ReadingLevel+ Factor, Margin= Absolute Level - Limit

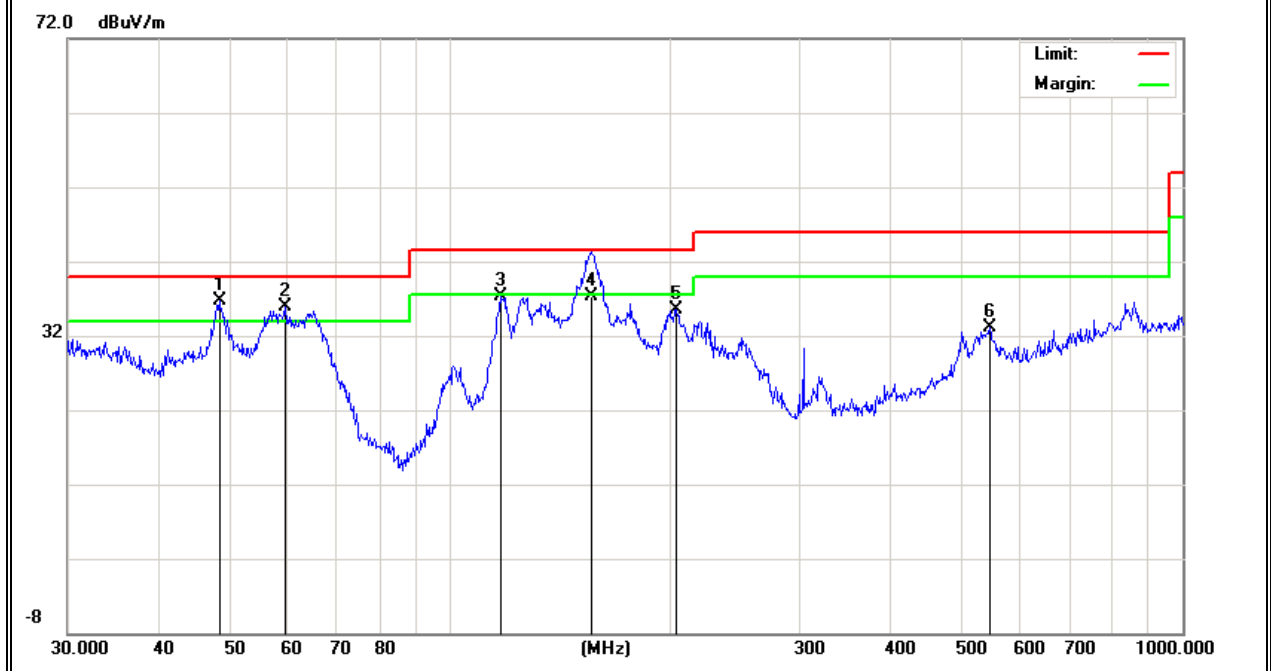

Polar (H/V)	Frequency	Meter Reading	Factor	Emission Level	Limits	Margin	Remark
	(MHz)	(dBuV)	(dB)	(dBuV/m)	(dBuV/m)	(dB)	
H	119.8555	21.23	12.07	33.30	43.50	-10.20	QP
H	155.9101	27.53	10.45	37.98	43.50	-5.52	QP
H	161.4742	25.94	10.50	36.44	43.50	-7.06	QP
H	203.5228	23.08	11.02	34.10	43.50	-9.40	QP
H	547.0977	14.86	21.27	36.13	46.00	-9.87	QP
H	782.3453	12.55	26.95	39.50	46.00	-6.50	QP

Remark:

Absolute Level= ReadingLevel+ Factor, Margin= Absolute Level - Limit

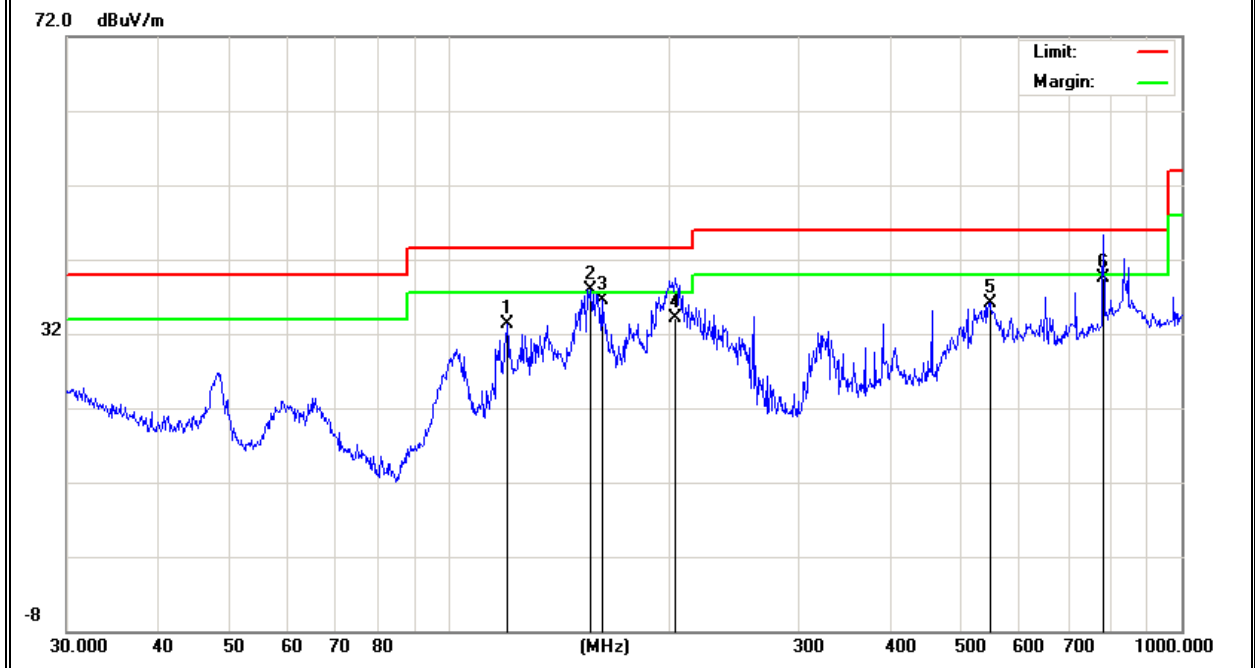

3.2.8 TEST RESULTS (ABOVE 1000 MHZ)

EUT :	2 in 1 tablet PC	Model Name :	JM101B
Temperature :	20 °C	Relative Humidity :	48%
Pressure :	1010 hPa	Test Voltage :	DC 3.8V
Test Mode :	TX		

Polar (H/V)	Frequency	Meter Reading	Factor	Emission Level	Limits	Margin	Detector Type
	(MHz)	(dBuV)	(dB)	(dBuV/m)	(dBuV/m)	(dB)	
Low Channel (2412 MHz)-Above 1G							
Vertical	4824.204	51.24	10.44	61.68	74.00	-12.32	Pk
Vertical	4824.204	35.69	10.44	46.13	54.00	-7.87	Av
Vertical	7236.188	44.51	12.39	56.90	74.00	-17.10	Pk
Vertical	7236.188	28.97	12.39	41.36	54.00	-12.64	Av
Horizontal	4824.296	53.12	10.44	63.56	74.00	-10.44	Pk
Horizontal	4824.296	32.67	10.44	43.11	54.00	-10.89	Av
Horizontal	7236.184	45.88	12.39	58.27	74.00	-15.73	Pk
Horizontal	7236.184	29.78	12.39	42.17	54.00	-11.83	Av
Mid Channel (2437 MHz)-Above 1G							
Vertical	4874.159	51.16	10.40	61.56	74.00	-12.44	Pk
Vertical	4874.159	32.05	10.40	42.45	54.00	-11.55	Av
Vertical	7311.321	47.84	12.75	60.59	74.00	-13.41	Pk
Vertical	7311.321	30.02	12.75	42.77	54.00	-11.23	Av
Horizontal	4874.166	50.08	10.40	60.48	74.00	-13.52	Pk
Horizontal	4874.166	31.14	10.40	41.54	54.00	-12.46	Av
Horizontal	7311.318	48.11	12.75	60.86	74.00	-13.14	Pk
Horizontal	7311.318	32.48	12.75	45.23	54.00	-8.77	Av
High Channel (2462 MHz)- Above 1G							
Vertical	4924.211	49.47	10.39	59.86	74.00	-14.14	Pk
Vertical	4924.211	33.55	10.39	43.94	54.00	-10.06	Av
Vertical	7386.167	45.68	12.68	58.36	74.00	-15.64	Pk
Vertical	7386.167	30.11	12.68	42.79	54.00	-11.21	Av
Horizontal	4924.327	49.78	10.39	60.17	74.00	-13.83	Pk
Horizontal	4924.327	32.04	10.39	42.43	54.00	-11.57	Av
Horizontal	7386.124	49.67	12.68	62.35	74.00	-11.65	Pk
Horizontal	7386.124	30.61	12.68	43.29	54.00	-10.71	Av

Note: "802.11b" mode is the worst mode.

4. POWER SPECTRAL DENSITY TEST

4.1 APPLIED PROCEDURES / LIMIT

FCC Part15 (15.247) , Subpart C				
Section	Test Item	Limit	Frequency Range (MHz)	Result
15.247	Power Spectral Density	8 dBm (in any 3KHz)	2400-2483.5	PASS

4.1.1 TEST PROCEDURE

1. Set analyzer center frequency to DTS channel center frequency.
2. Set the span to 1.5 times the DTS channel bandwidth.
3. 3 kHz ≤ Set the RBW ≤ 100 kHz.
4. Set the VBW ≥ 3 x RBW.
5. Detector = peak.
6. Sweep time = auto couple.
7. Trace mode = max hold.
8. Allow trace to fully stabilize.
9. Use the peak marker function to determine the maximum amplitude level within the RBW.
10. If measured value exceeds limit, reduce RBW (no less than 3 kHz) and repeat.

4.1.2 DEVIATION FROM STANDARD

No deviation.

4.1.3 TEST SETUP



4.1.4 EUT OPERATION CONDITIONS

The EUT tested system was configured as the statements of 2.1 Unless otherwise a special operating condition is specified in the follows during the testing.

4.1.5 TEST RESULTS

EUT :	2 in 1 tablet PC	Model Name :	JM101B
Temperature :	25 °C	Relative Humidity :	56%
Pressure :	1015 hPa	Test Voltage :	DC 3.8V
Test Mode :	TX b Mode /CH01, CH06, CH11		

Frequency	Power Density (dBm)	Limit (dBm)	Result
2412 MHz	-13.85	8	PASS
2437 MHz	-12.33	8	PASS
2462 MHz	-12.23	8	PASS

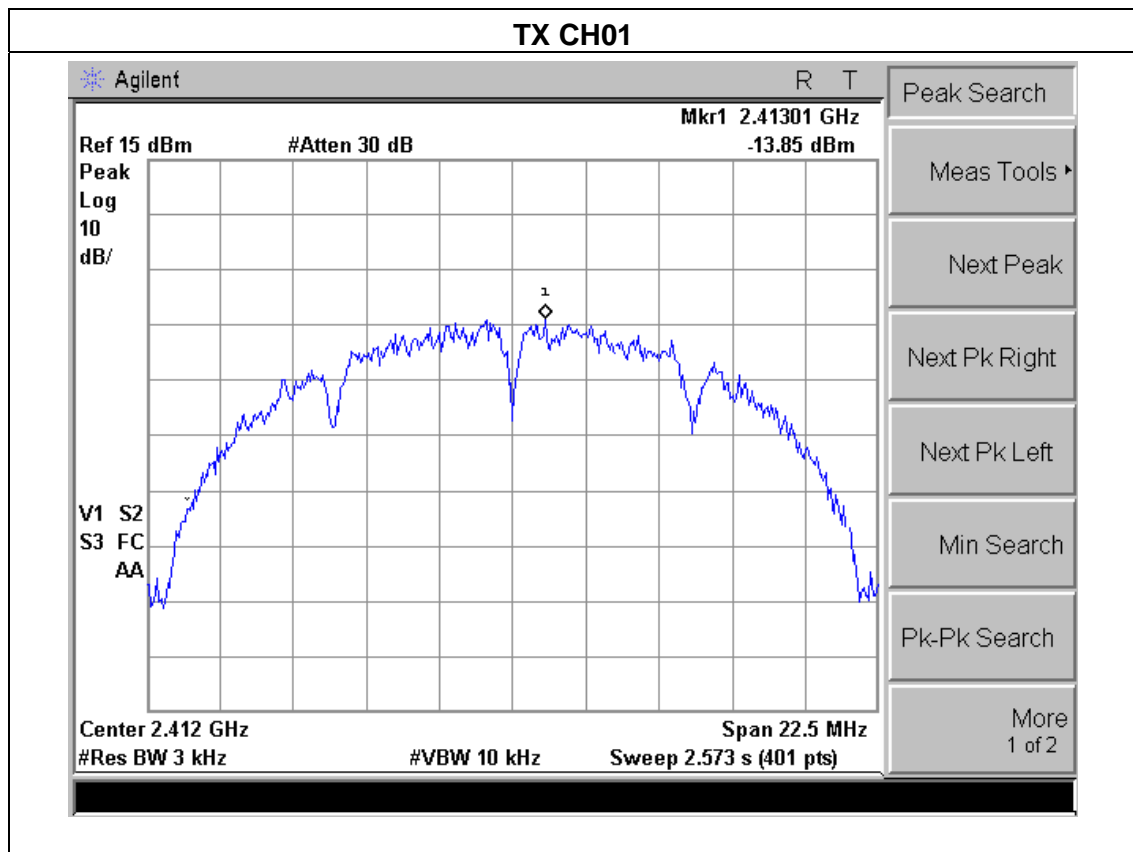

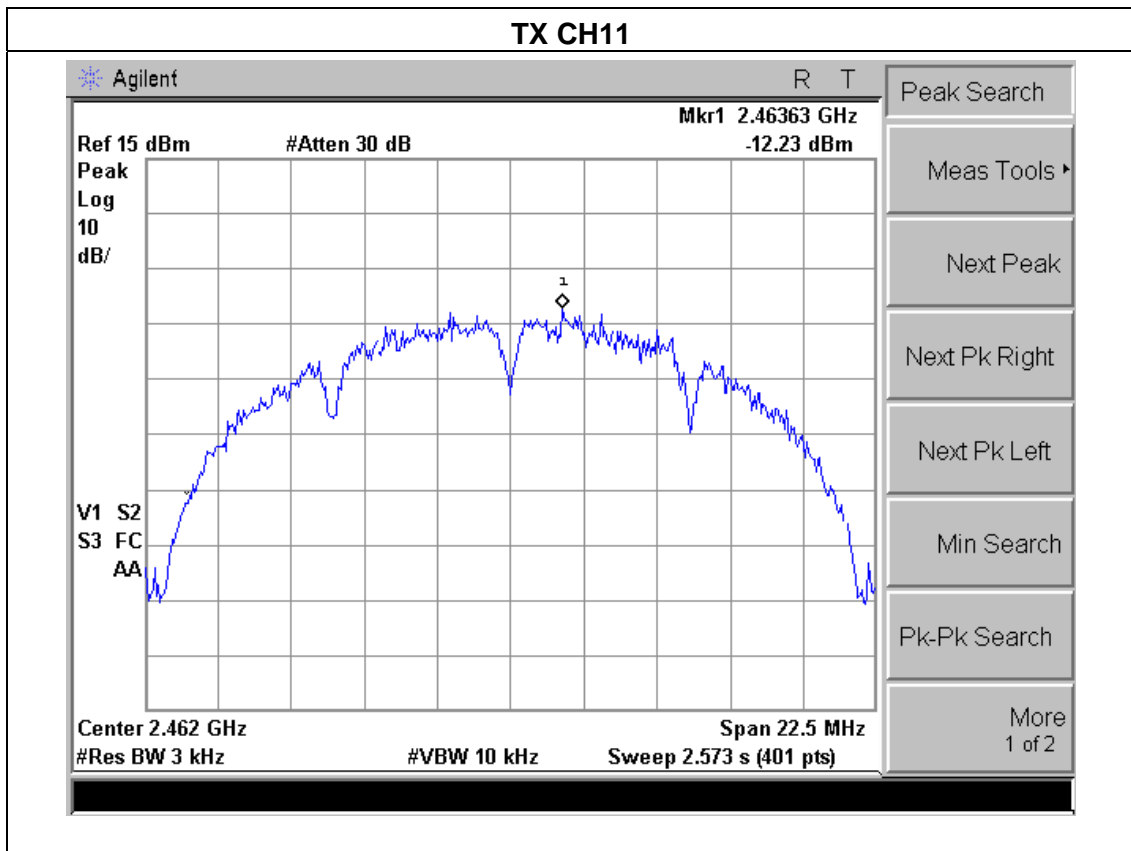
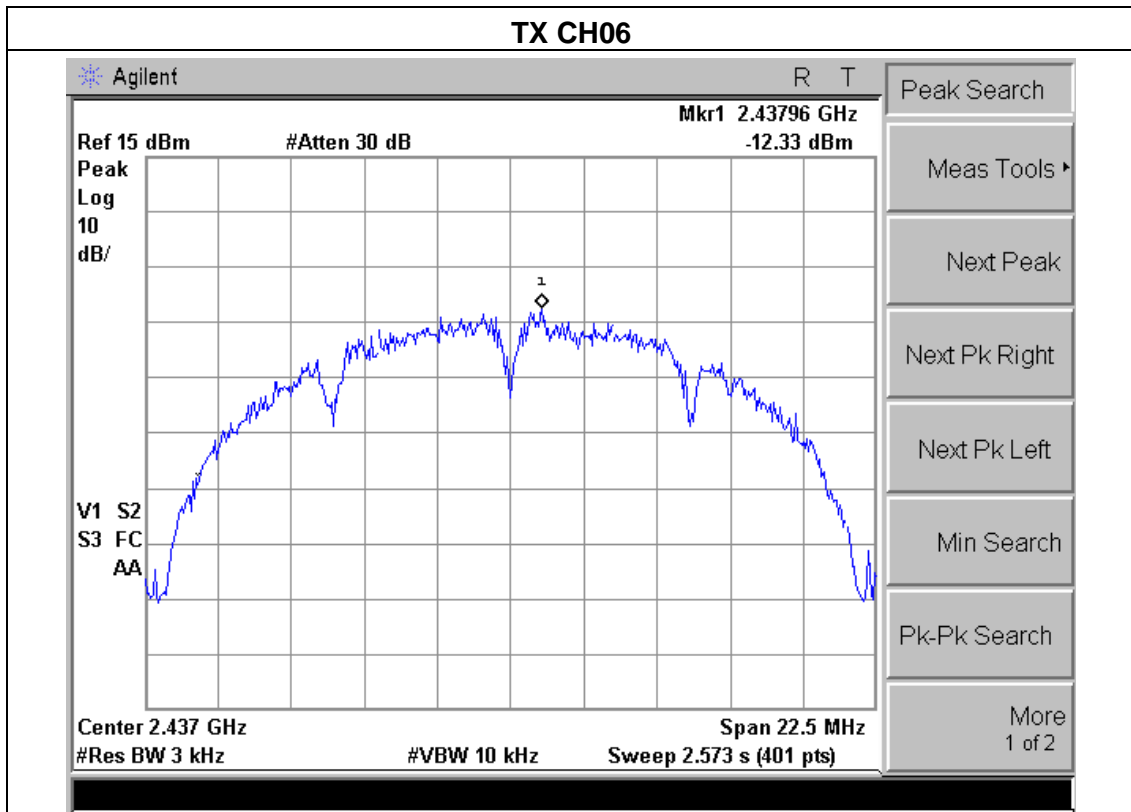

EUT :	2 in 1 tablet PC	Model Name :	JM101B
Temperature :	25 °C	Relative Humidity :	56%
Pressure :	1015 hPa	Test Voltage :	DC 3.8V
Test Mode :	TX g Mode /CH01, CH06, CH11		

Frequency	Power Density (dBm)	Limit (dBm)	Result
2412 MHz	-20.39	8	PASS
2437 MHz	-19.18	8	PASS
2462 MHz	-19.04	8	PASS

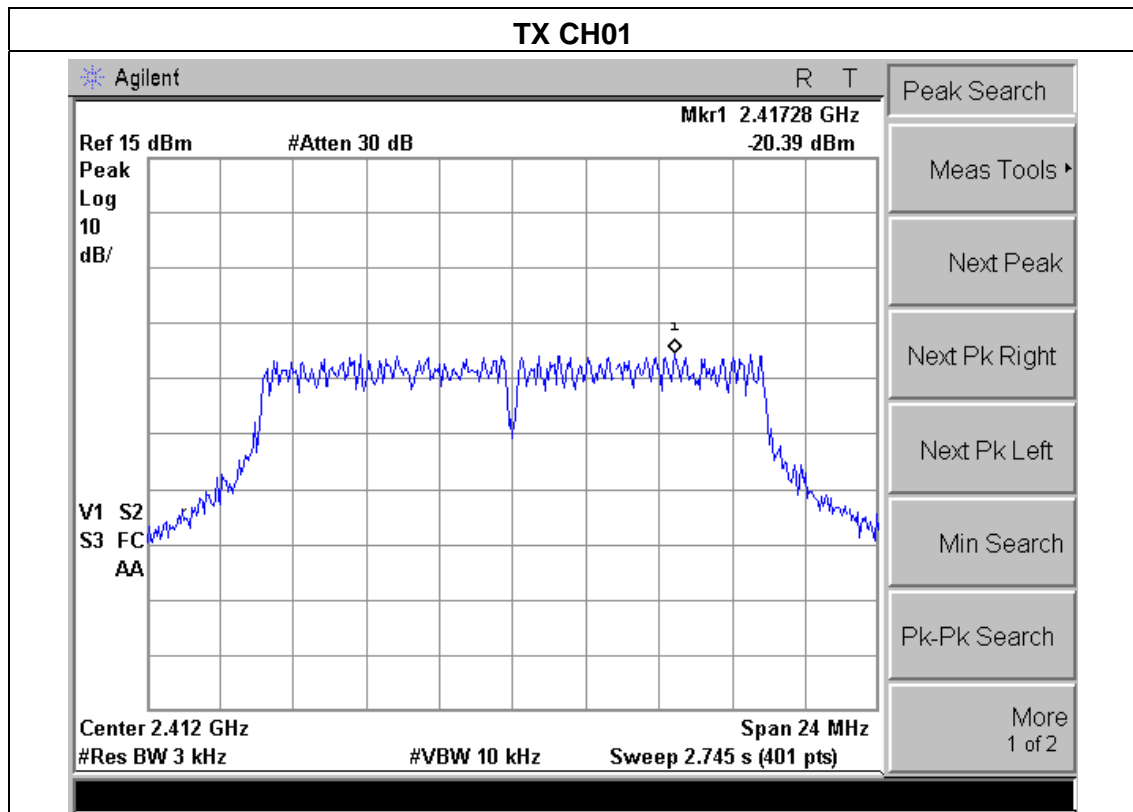

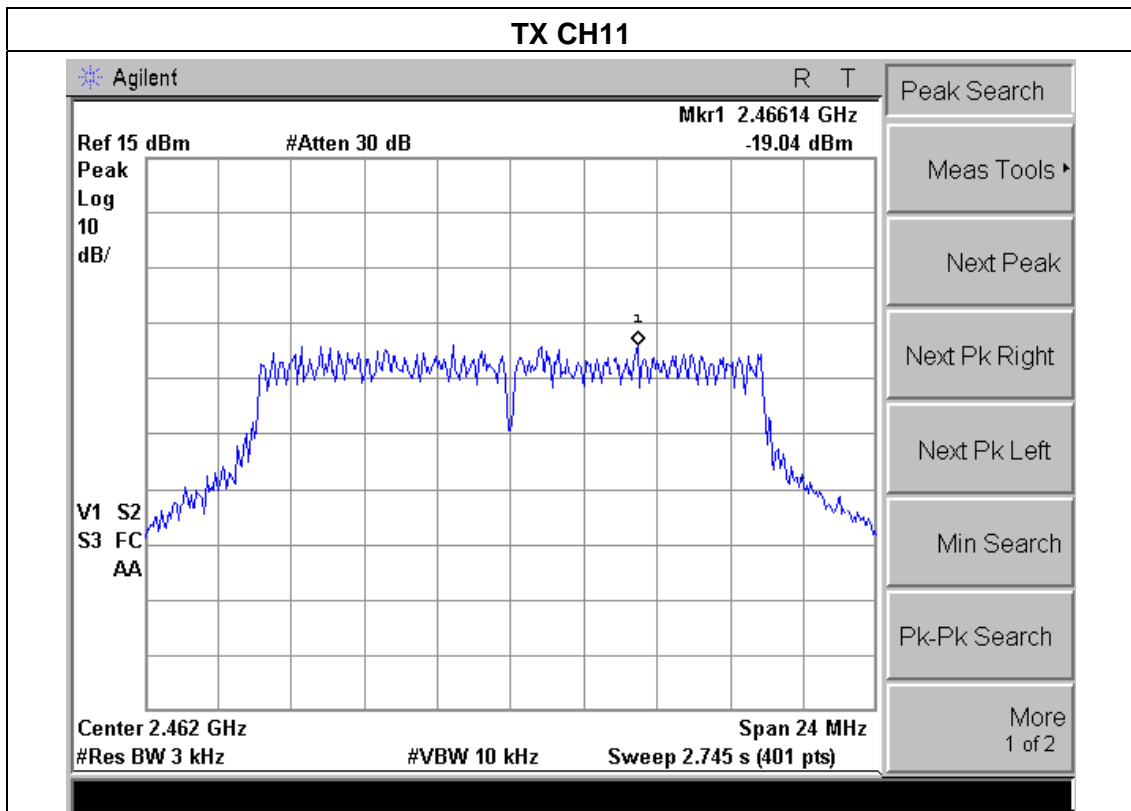
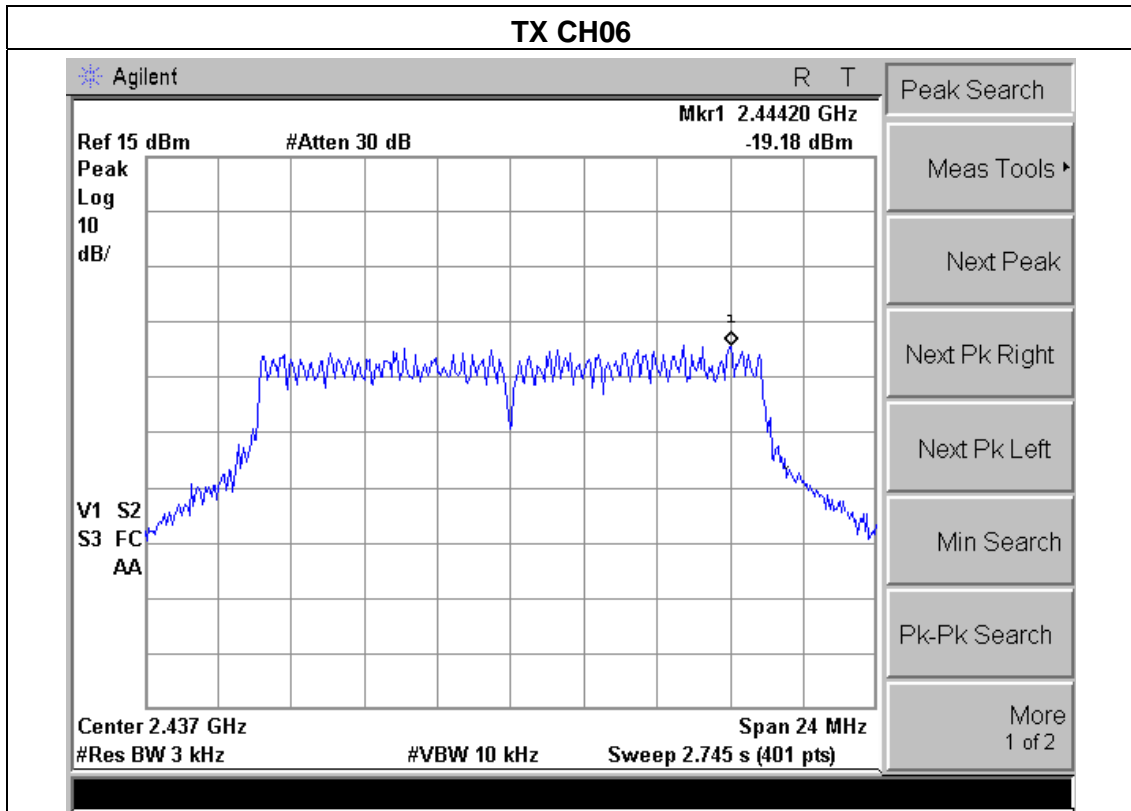

EUT :	2 in 1 tablet PC	Model Name :	JM101B
Temperature :	25 °C	Relative Humidity :	56%
Pressure :	1015 hPa	Test Voltage :	DC 3.8V
Test Mode :	TX n Mode (20MHz)/CH01, CH06, CH11		

Frequency	Power Density (dBm)	Limit (dBm)	Result
2412 MHz	-19.93	8	PASS
2437 MHz	-20.24	8	PASS
2462 MHz	-19.34	8	PASS

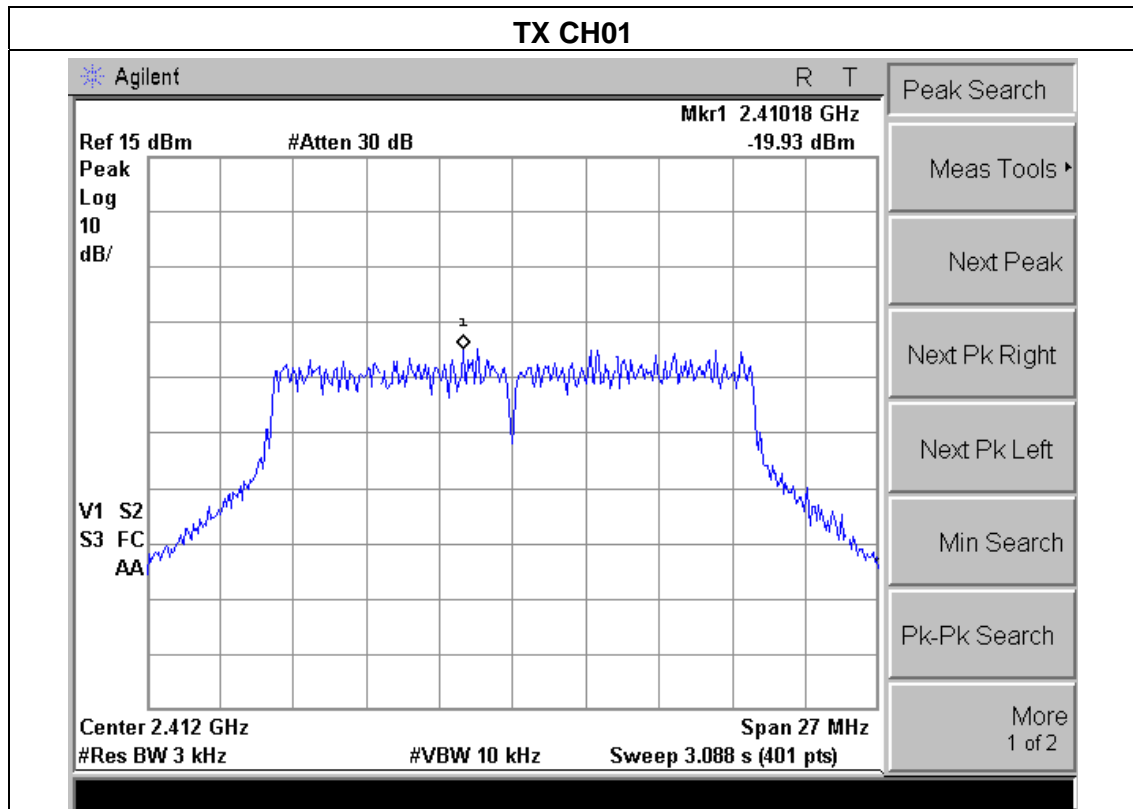

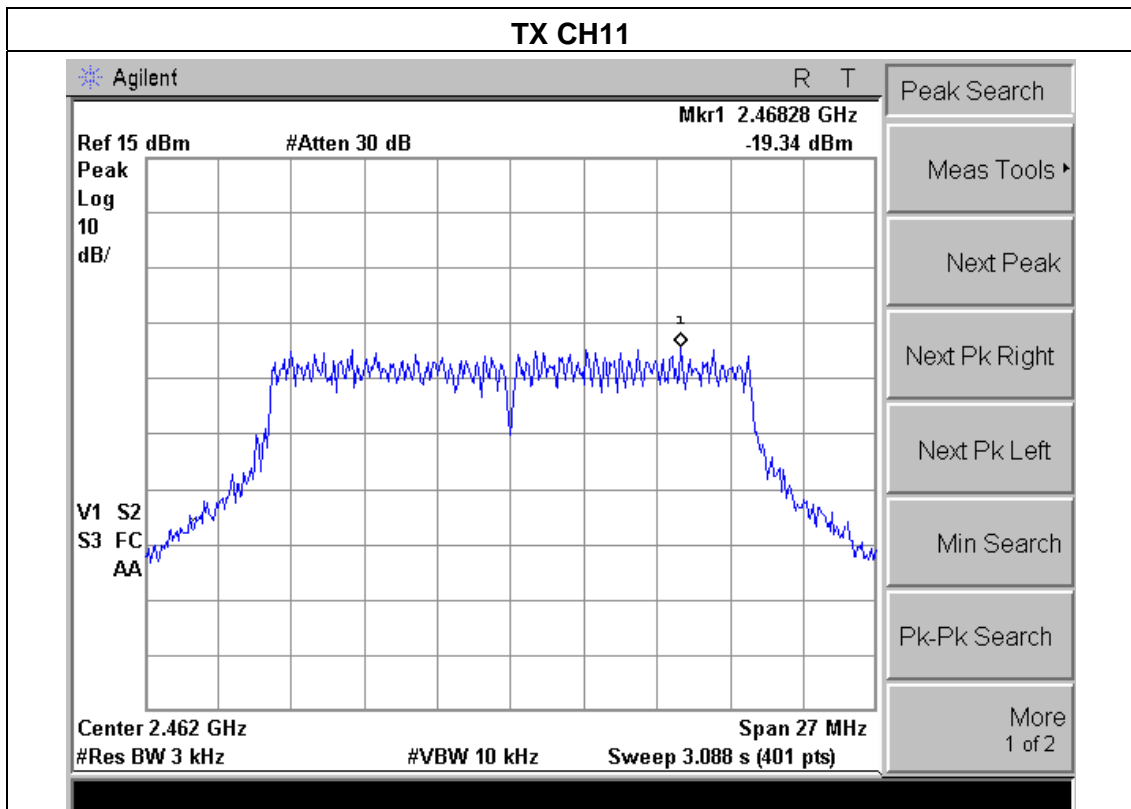
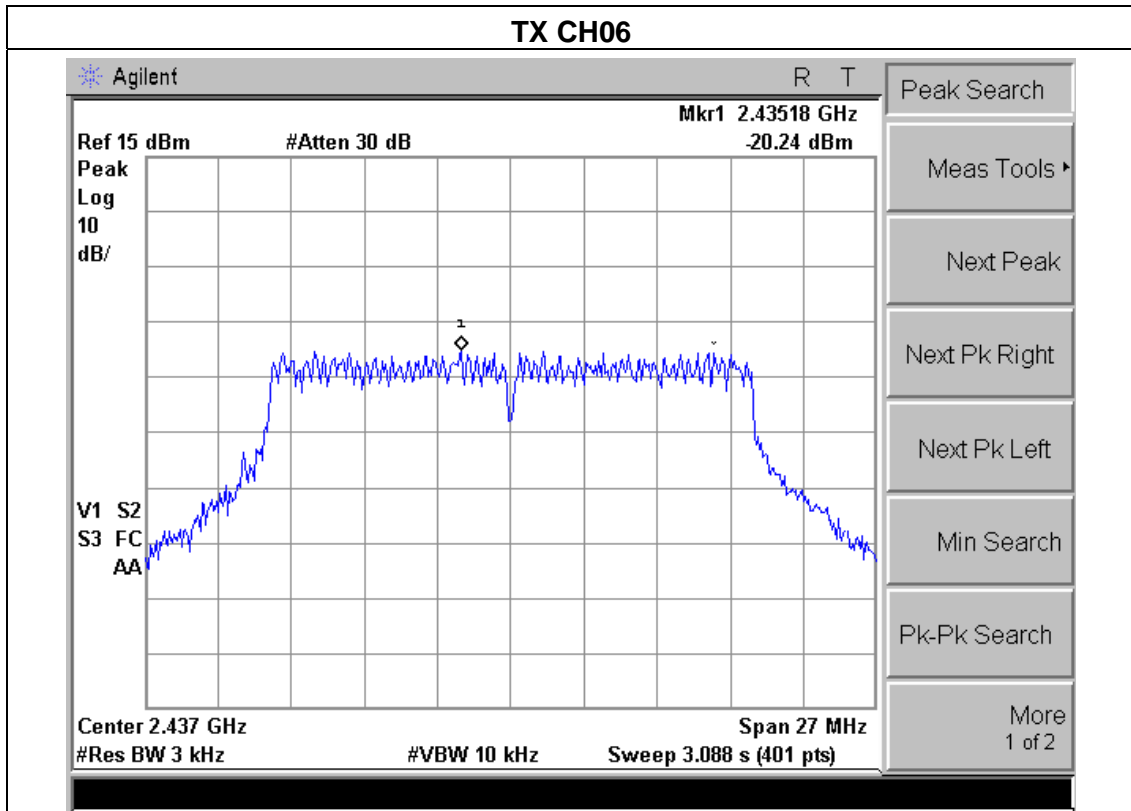

EUT :	2 in 1 tablet PC	Model Name :	JM101B
Temperature :	25 °C	Relative Humidity :	56%
Pressure :	1015 hPa	Test Voltage :	DC 3.8V
Test Mode :	TX n Mode (40MHz)/CH03, CH06, CH09		

Frequency	Power Density (dBm)	Limit (dBm)	Result
2422 MHz	-23.51	8	PASS
2437 MHz	-21.77	8	PASS
2452 MHz	-20.52	8	PASS

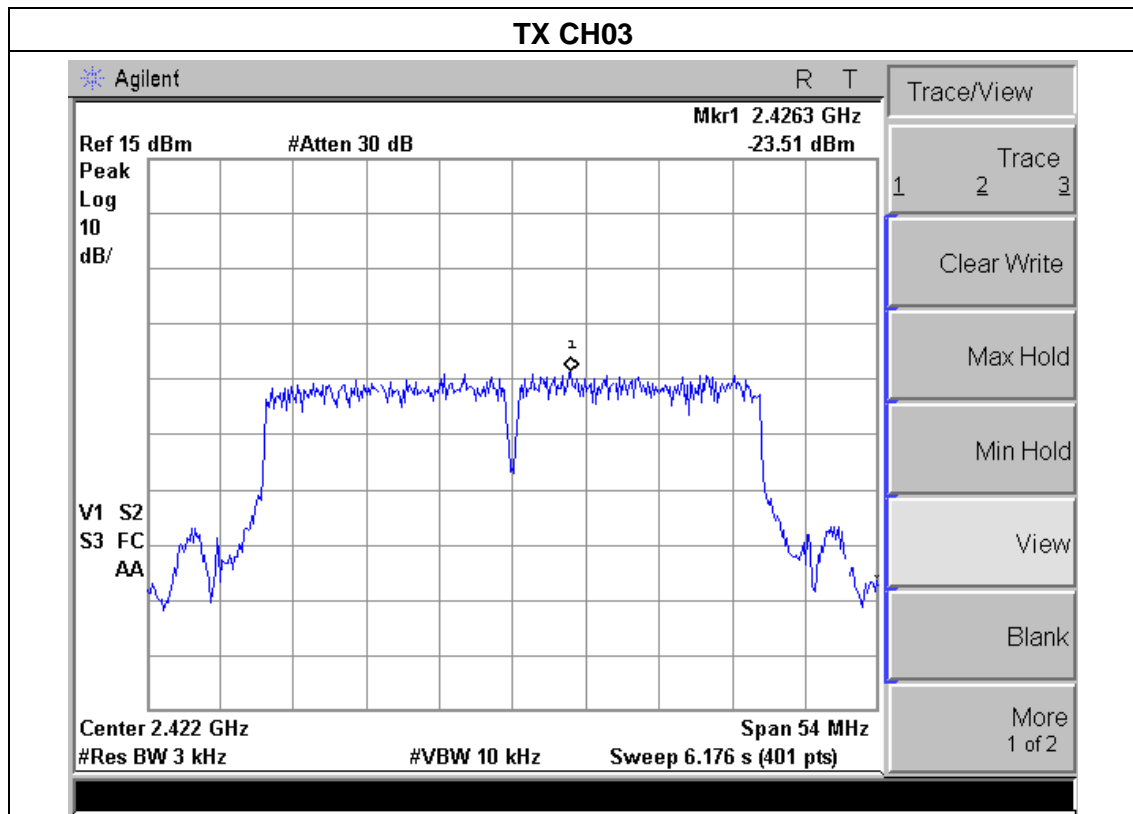

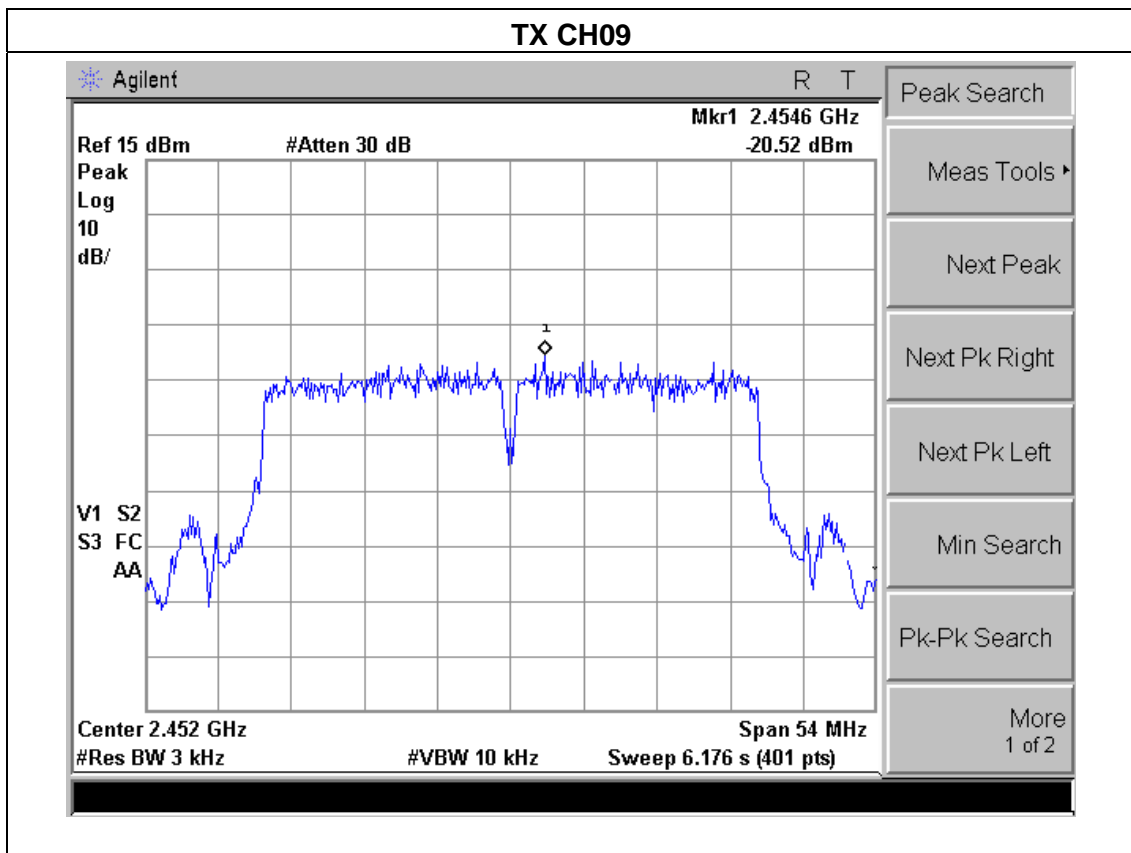
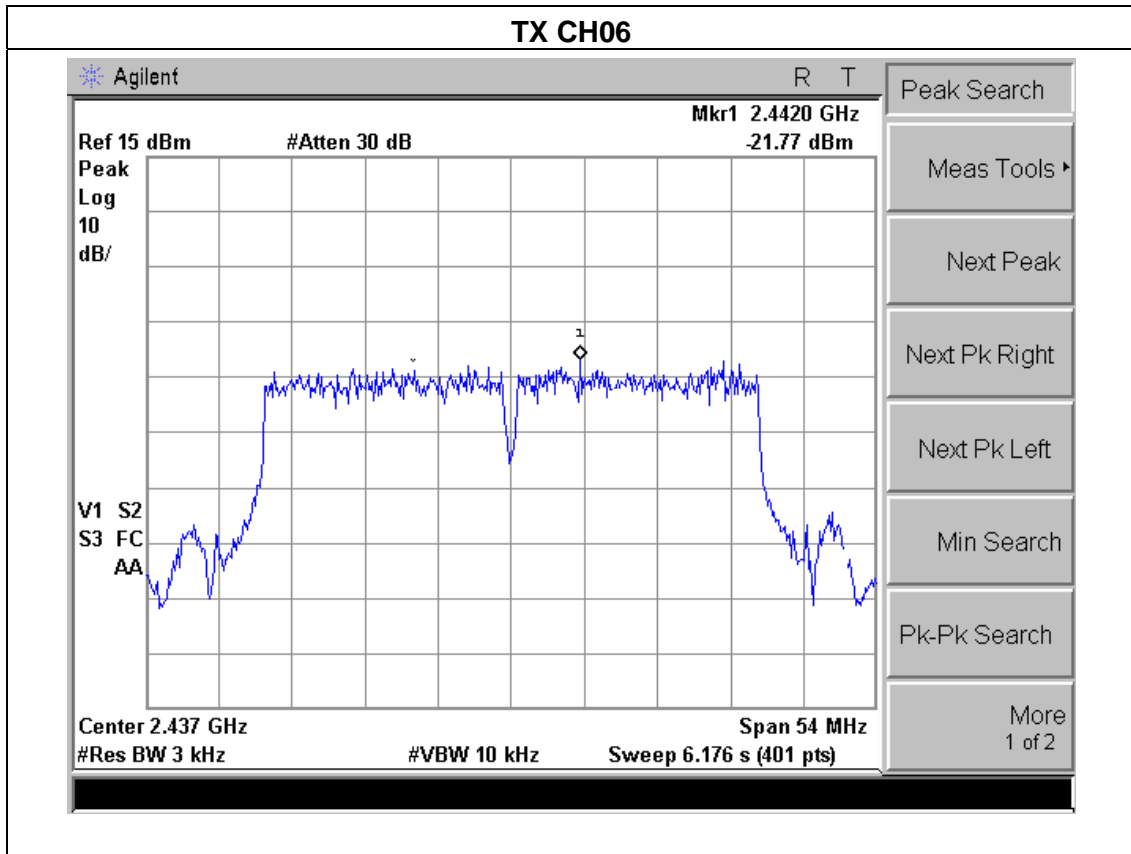

5. BANDWIDTH TEST

5.1 APPLIED PROCEDURES / LIMIT

FCC Part15 (15.247) , Subpart C				
Section	Test Item	Limit	Frequency Range (MHz)	Result
15.247(a)(2)	Bandwidth	$\geq 500\text{KHz}$ (6dB bandwidth)	2400-2483.5	PASS

5.1.1 TEST PROCEDURE

1. Set RBW = 100 kHz.
2. Set the video bandwidth (VBW) $\geq 3 \times$ RBW.
3. Detector = Peak.
4. Trace mode = max hold.
5. Sweep = auto couple.
6. Allow the trace to stabilize.
7. Measure the maximum width of the emission that is constrained by the frequencies associated with the two outermost amplitude points (upper and lower) that are attenuated by 6 dB relative to the maximum level measured in the fundamental emission.

TEST SETUP

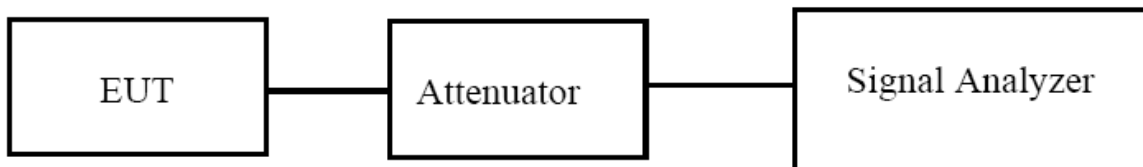

5.1.2 EUT OPERATION CONDITIONS

The EUT tested system was configured as the statements of 2.4 Unless otherwise a special operating condition is specified in the follows during the testing.

5.1.3 TEST RESULTS

EUT :	2 in 1 tablet PC	Model Name :	JM101B
Temperature :	25 °C	Relative Humidity :	56%
Pressure :	1012 hPa	Test Voltage :	DC 3.8V
Test Mode :	TX b Mode /CH01, CH06, CH11		

Channel	Frequency (MHz)	6dB bandwidth (MHz)	Limit (kHz)	Result
Low	2412	10.089	500	Pass
Middle	2437	10.089	500	Pass
High	2462	10.092	500	Pass

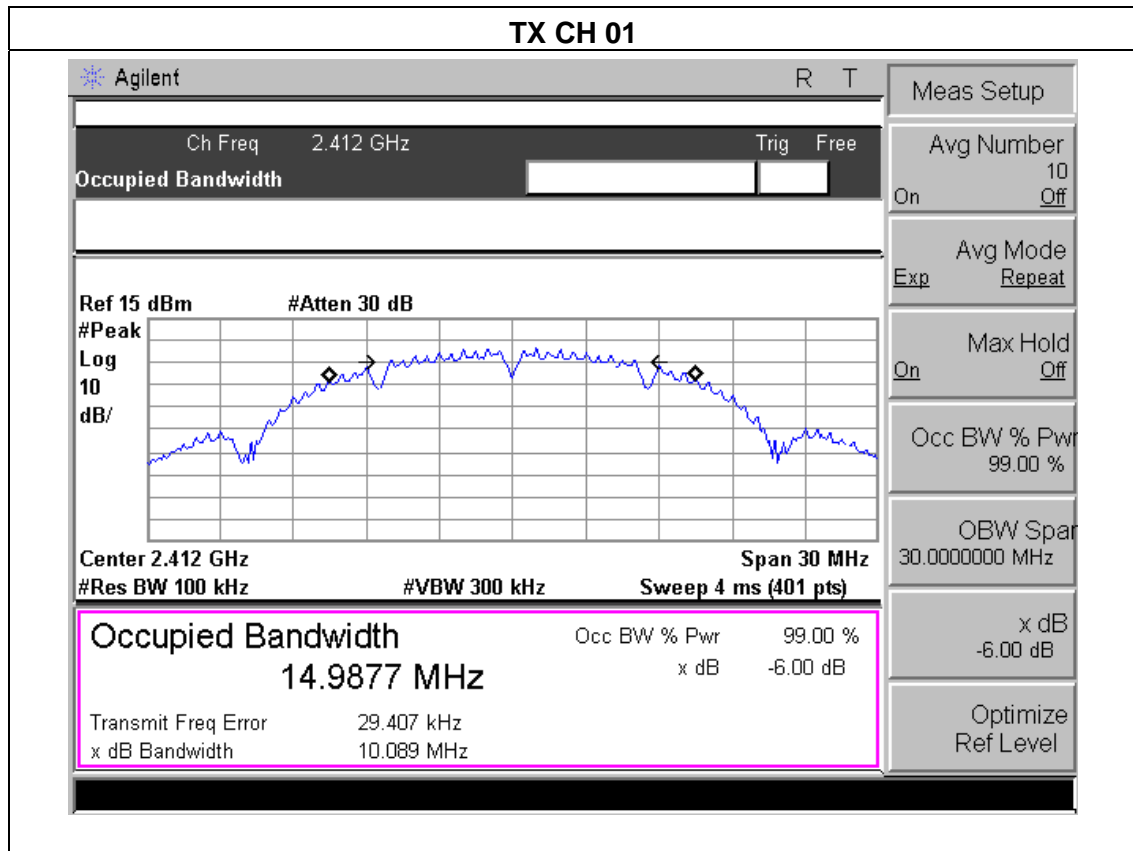

TX CH 06

Agilent		R	T	Meas Setup	
Ch Freq 2.437 GHz		Trig Free		Avg Number 10	
Occupied Bandwidth				On Off	
Ref 15 dBm #Atten 30 dB				Avg Mode Repeat	
				Max Hold On Off	
Center 2.437 GHz Span 30 MHz				Occ BW % Pwr 99.00 %	
#Res BW 100 kHz #VBW 300 kHz Sweep 4 ms (401 pts)				OBW Span 30.0000000 MHz	
Occupied Bandwidth 14.9886 MHz		Occ BW % Pwr 99.00 %		x dB -6.00 dB	
Transmit Freq Error 12.217 kHz				Optimize Ref Level	
x dB Bandwidth 10.089 MHz					

TX CH 11

Agilent		R	T	Meas Setup	
Ch Freq 2.462 GHz		Trig Free		Avg Number 10	
Occupied Bandwidth				On Off	
Ref 15 dBm #Atten 30 dB				Avg Mode Repeat	
				Max Hold On Off	
Center 2.462 GHz Span 30 MHz				Occ BW % Pwr 99.00 %	
#Res BW 100 kHz #VBW 300 kHz Sweep 4 ms (401 pts)				OBW Span 30.0000000 MHz	
Occupied Bandwidth 14.9794 MHz		Occ BW % Pwr 99.00 %		x dB -6.00 dB	
Transmit Freq Error 2.048 kHz				Optimize Ref Level	
x dB Bandwidth 10.092 MHz					

EUT :	2 in 1 tablet PC	Model Name :	JM101B
Temperature :	25 °C	Relative Humidity :	60%
Pressure :	1012 hPa	Test Voltage :	DC 3.8V
Test Mode :	TX g Mode /CH01, CH06, CH11		

Channel	Frequency (MHz)	6dB bandwidth (MHz)	Limit (kHz)	Result
Low	2412	16.402	500	Pass
Middle	2437	16.337	500	Pass
High	2462	16.439	500	Pass

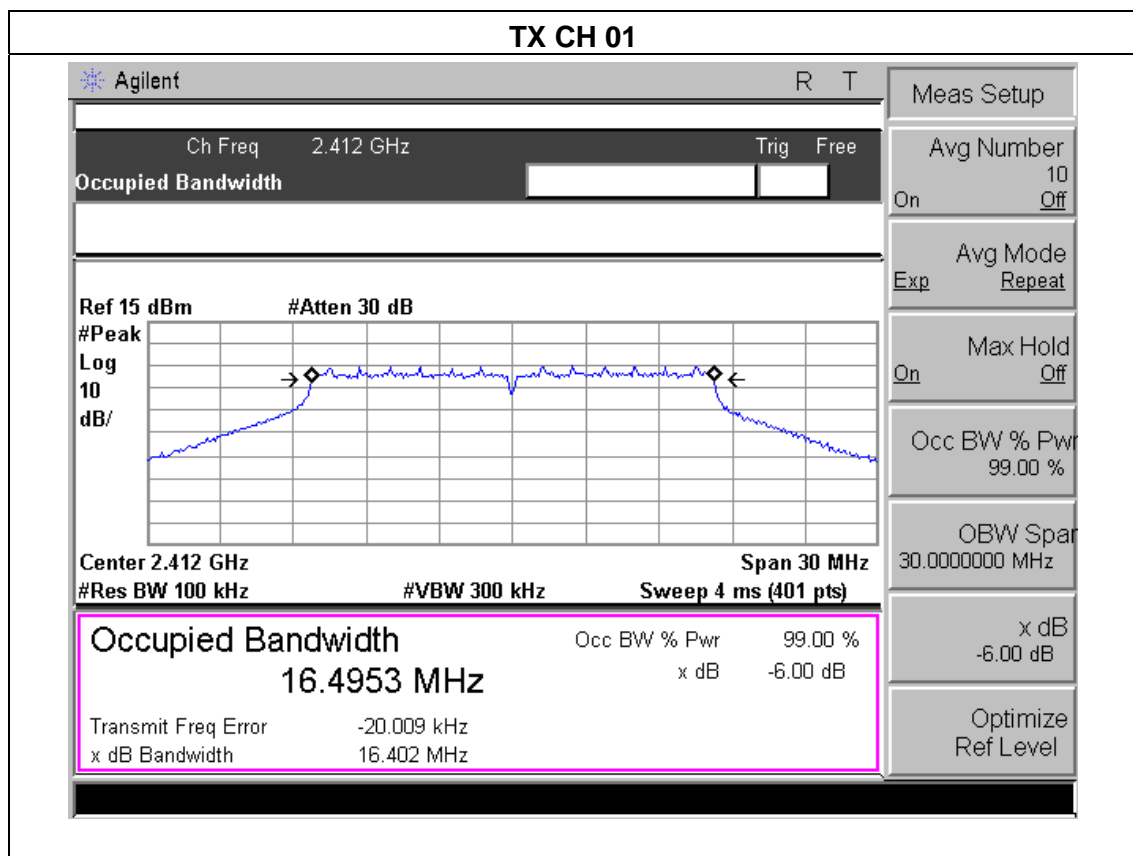

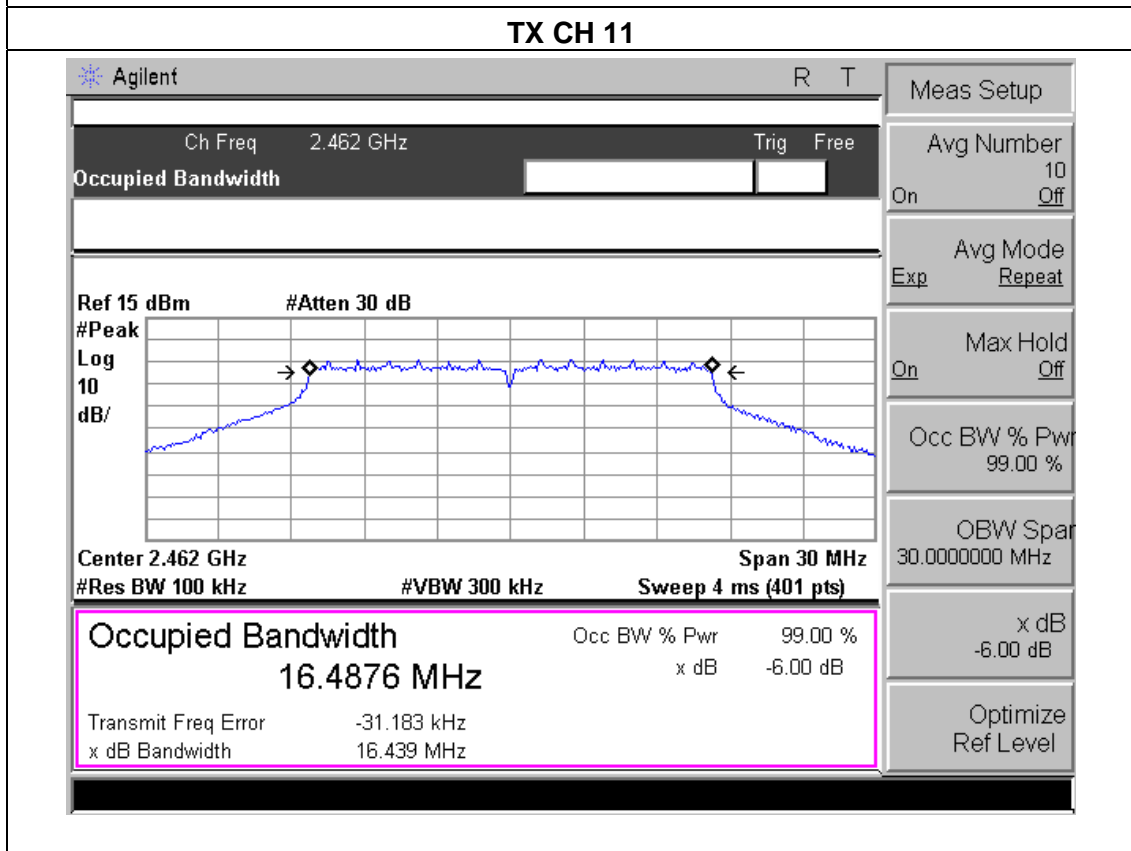
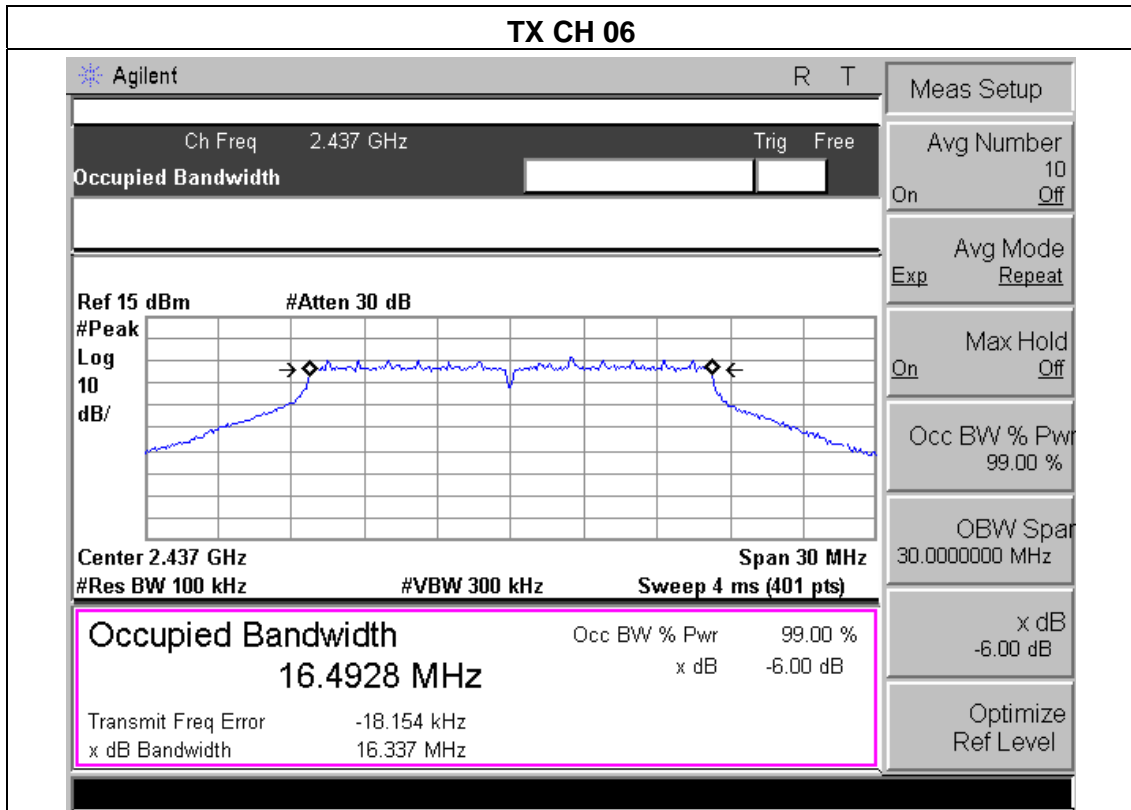

EUT :	2 in 1 tablet PC	Model Name :	JM101B
Temperature :	25 °C	Relative Humidity :	56%
Pressure :	1012 hPa	Test Voltage :	DC 3.8V
Test Mode :	TX n Mode(20M) /CH01, CH06, CH11		

Channel	Frequency (MHz)	6dB bandwidth (MHz)	Limit (kHz)	Result
Low	2412	17.621	500	Pass
Middle	2437	17.642	500	Pass
High	2462	17.639	500	Pass

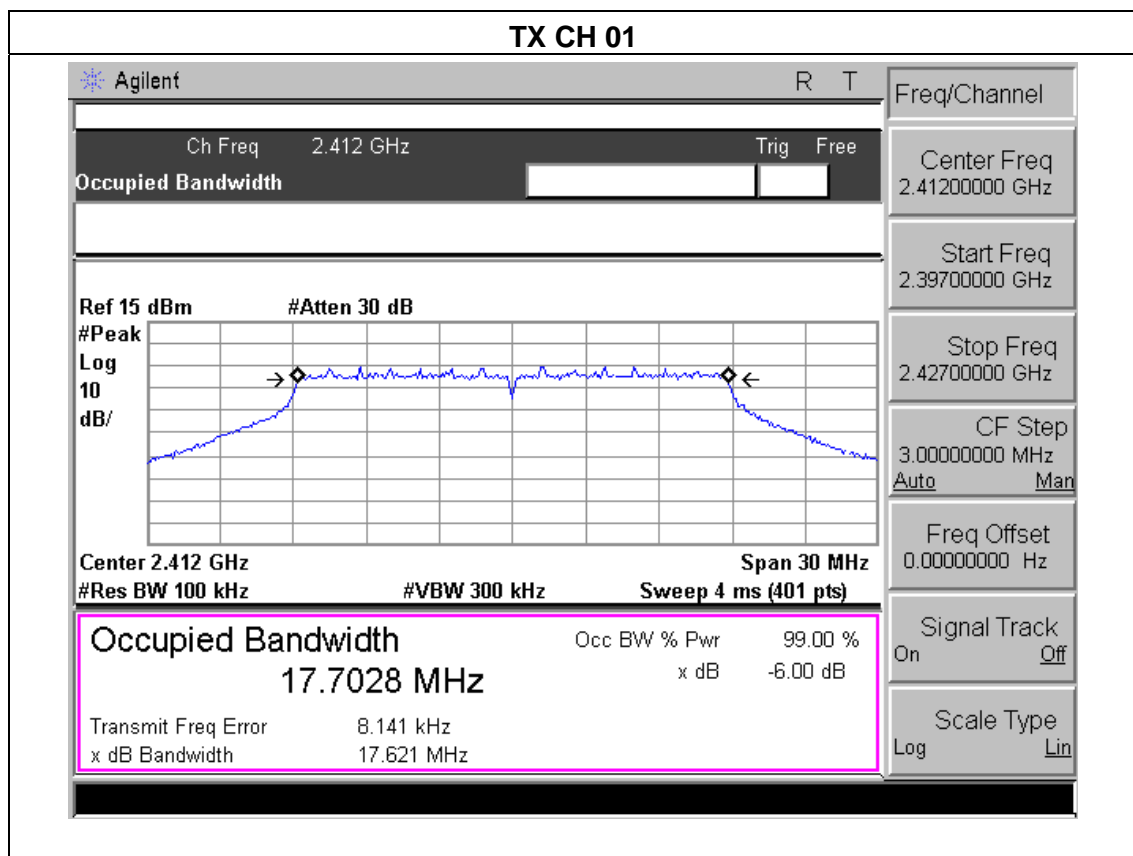

TX CH 06

Agilent R T

Ch Freq 2.437 GHz Trig Free

Occupied Bandwidth [] []

Ref 15 dBm #Atten 30 dB

#Peak

Log 10 dB/

Center 2.437 GHz Span 30 MHz

#Res BW 100 kHz #VBW 300 kHz Sweep 4 ms (401 pts)

Occupied Bandwidth		Occ BW % Pwr	99.00 %
17.7027 MHz		x dB	-6.00 dB
Transmit Freq Error	-3.858 kHz		
x dB Bandwidth	17.642 MHz		

Freq/Channel

Center Freq 2.43700000 GHz

Start Freq 2.42200000 GHz

Stop Freq 2.45200000 GHz

CF Step 3.00000000 MHz
Auto Man

Freq Offset 0.00000000 Hz

Signal Track On Off

Scale Type Log Lin

TX CH 11

Agilent R T

Ch Freq 2.462 GHz Trig Free

Occupied Bandwidth [] []

Ref 15 dBm #Atten 30 dB

#Peak

Log 10 dB/

Center 2.462 GHz Span 30 MHz

#Res BW 100 kHz #VBW 300 kHz Sweep 4 ms (401 pts)

Occupied Bandwidth		Occ BW % Pwr	99.00 %
17.7086 MHz		x dB	-6.00 dB
Transmit Freq Error	4.479 kHz		
x dB Bandwidth	17.639 MHz		

Freq/Channel

Center Freq 2.46200000 GHz

Start Freq 2.44700000 GHz

Stop Freq 2.47700000 GHz

CF Step 3.00000000 MHz
Auto Man

Freq Offset 0.00000000 Hz

Signal Track On Off

Scale Type Log Lin

EUT :	2 in 1 tablet PC	Model Name :	JM101B
Temperature :	25 °C	Relative Humidity :	56%
Pressure :	1012 hPa	Test Voltage :	DC 3.8V
Test Mode :	TX n Mode(40M) /CH03, CH06, CH09		

Channel	Frequency (MHz)	6dB bandwidth (MHz)	Limit (kHz)	Result
Low	2422	35.745	500	Pass
Middle	2437	35.734	500	Pass
High	2452	35.784	500	Pass

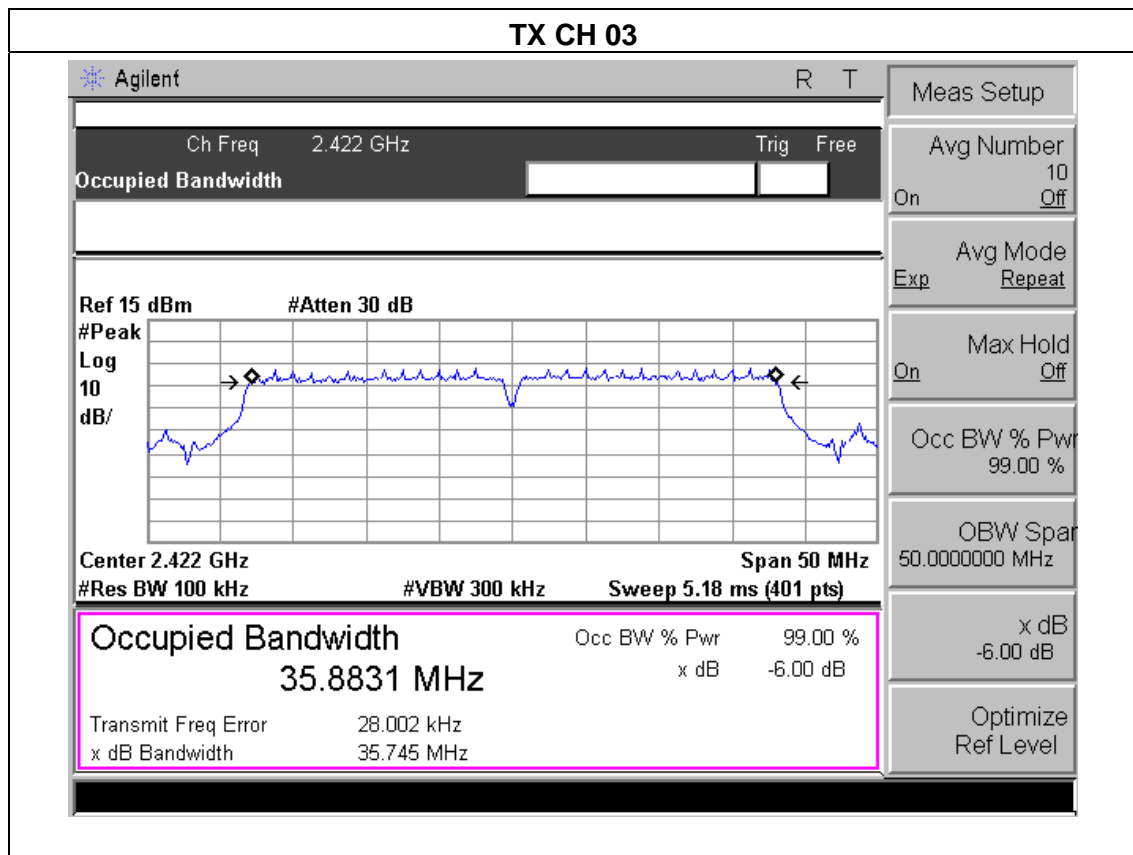

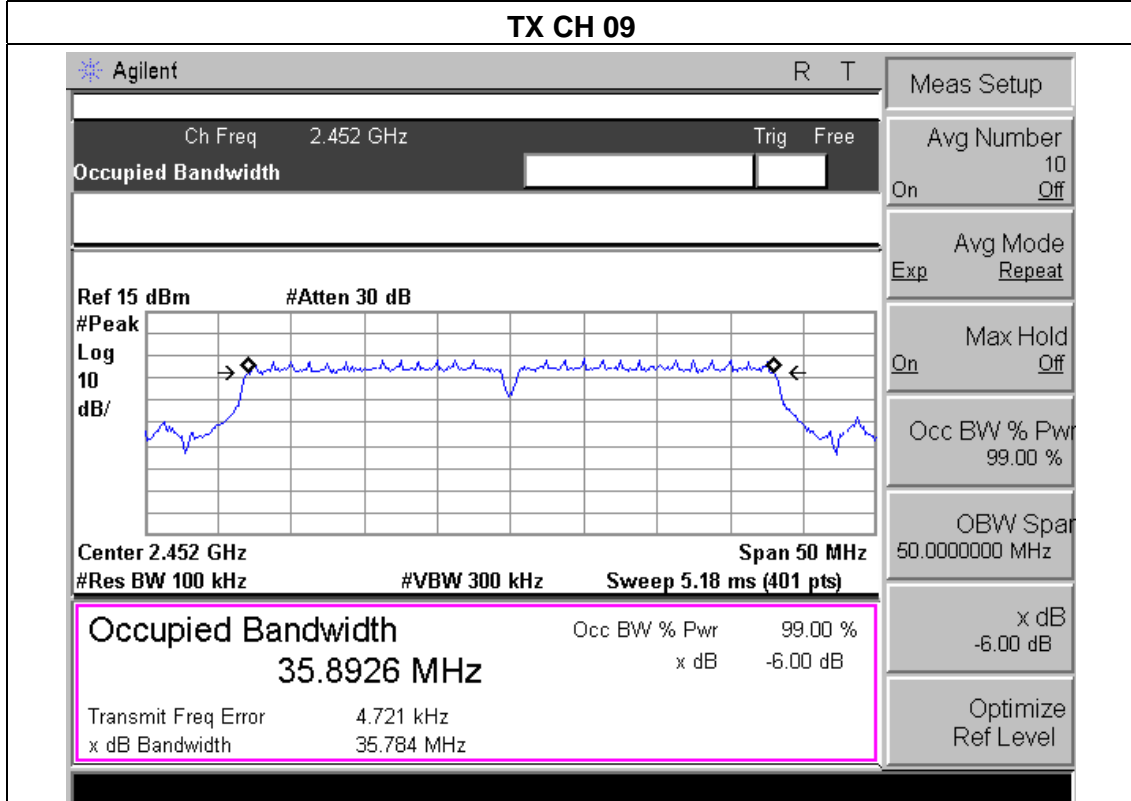
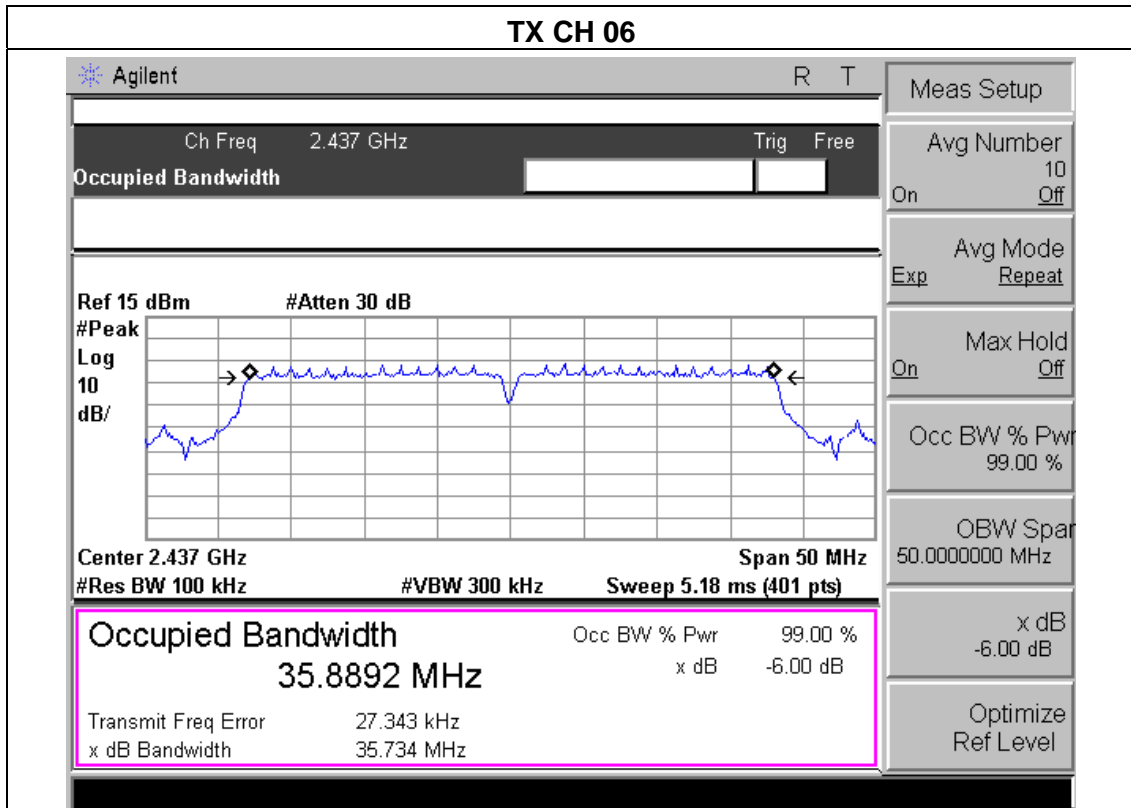

6. PEAK OUTPUT POWER TEST

6.1 APPLIED PROCEDURES / LIMIT

FCC Part15 (15.247) , Subpart C				
Section	Test Item	Limit	Frequency Range (MHz)	Result
15.247(b)(3)	Peak Output Power	1 watt or 30dBm	2400-2483.5	PASS

6.1.1 TEST PROCEDURE

- a. The EUT was directly connected to the Power meter

6.1.2 DEVIATION FROM STANDARD

No deviation.

6.1.3 TEST SETUP

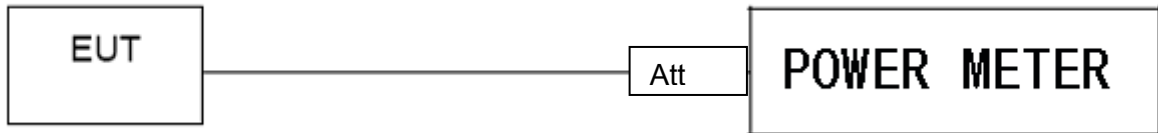

6.1.4 EUT OPERATION CONDITIONS

The EUT tested system was configured as the statements of 2.4 Unless otherwise a special operating condition is specified in the follows during the testing.

6.1.5 TEST RESULTS

EUT :	2 in 1 tablet PC	Model Name :	JM101B
Temperature :	25 °C	Relative Humidity :	60%
Pressure :	1012 hPa	Test Voltage :	DC 3.8V
Test Mode :	TX b/g/n(20M/40M) Mode		

TX 802.11b Mode				
Test Channel	Frequency	Maximum Peak Conducted Output Power (PK)	Maximum Peak Conducted Output Power (AV)	LIMIT
	(MHz)	(dBm)	(dBm)	dBm
CH01	2412	12.58	9.53	30
CH06	2437	12.67	9.59	30
CH11	2462	12.59	9.51	30
TX 802.11g Mode				
CH01	2412	11.26	8.25	30
CH06	2437	11.03	8.02	30
CH11	2462	10.97	7.96	30
TX 802.11n(20) Mode				
CH01	2412	9.98	7.34	30
CH06	2437	10.01	7.37	30
CH11	2462	9.87	7.23	30
TX 802.11n(40) Mode				
CH03	2422	8.97	6.55	30
CH06	2437	8.69	6.27	30
CH09	2452	8.81	6.39	30

7. 100 KHZ BANDWIDTH OF FREQUENCY BAND EDGE

APPLICABLE STANDARD

In any 100 kHz bandwidth outside the frequency band in which the spread spectrum or digitally modulated intentional radiator is operating, the radio frequency power that is produced by the intentional radiator shall be at least 20 dB below that in the 100 kHz bandwidth within the band that contains the highest level of the desired power, based on either an RF conducted or a radiated measurement, provided the transmitter demonstrates compliance with the peak conducted power limits. If the transmitter complies with the conducted power limits based on the use of RMS averaging over a time interval, as permitted under paragraph (b)(3) of this section, the attenuation required under this paragraph shall be 30 dB instead of 20 dB. Attenuation below the general limits specified in §15.209(a) is not required. In addition, radiated emissions which fall in the restricted bands, as defined in §15.205(a), must also comply with the radiated emission limits specified in §15.209(a) (see §15.205(c)).

TEST PROCEDURE

- a) Check the calibration of the measuring instrument using either an internal calibrator or a known signal from an external generator.
- b) Position the EUT without connection to measurement instrument. Turn on the EUT and connect its antenna terminal to measurement instrument via a low loss cable. Then set it to any one measured frequency within its operating range, and make sure the instrument is operated in its linear range.
- c) Set RBW to 100 kHz and VBW of spectrum analyzer to 300 kHz with a convenient frequency span including 100 kHz bandwidth from band edge.
- d) Measure the highest amplitude appearing on spectral display and set it as a reference level. Plot the graph with marking the highest point and edge frequency.
- e) Repeat above procedures until all measured frequencies were complete.

7.1 DEVIATION FROM STANDARD

No deviation.

7.2 TEST SETUP

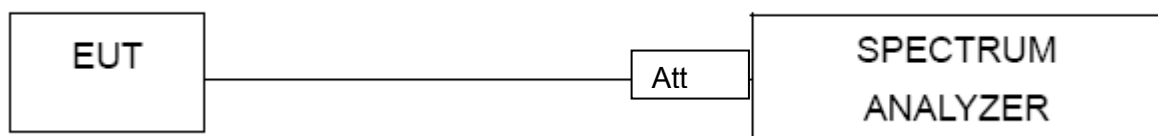

7.3 EUT OPERATION CONDITIONS

The EUT tested system was configured as the statements of 2.4 Unless otherwise a special operating condition is specified in the follows during the testing.

7.4 TEST RESULTS

EUT :	2 in 1 tablet PC	Model Name :	JM101B
Temperature :	25 °C	Relative Humidity :	56%
Pressure :	1012 hPa	Test Voltage :	DC 3.8V

Frequency Band MHz	Delta Peak to band emission (dBc)	> Limit (dBc)	Result
802.11b mode			
2400	37.56	20	Pass
2483.5	54.74	20	Pass
802.11g mode			
2400	32.02	20	Pass
2483.5	47.93	20	Pass
802.11n-HT20 mode			
2400	28.62	20	Pass
2483.5	49.62	20	Pass
802.11n-HT40 mode			
2400	32.66	20	Pass
2483.5	43.13	20	Pass

Radiated band edge:

Frequency (MHz)	Meter Reading (dBμV)	Factor (dB)	Emission Level (dBμV/m)	Limits (dBμV/m)	Margin (dB)	Detector Type	Comment
802.11b							
2390	66.61	-13.06	53.55	74	-20.45	peak	Vertical
2390	66.73	-13.06	53.67	74	-20.33	peak	Horizontal
2483.5	66.64	-12.78	53.86	74	-20.14	peak	Vertical
2483.5	66.41	-12.78	53.63	74	-20.37	peak	Horizontal
802.11g							
2390	63.42	-13.06	50.36	74	-23.64	peak	Vertical
2390	65.34	-13.06	52.28	74	-21.72	peak	Horizontal
2483.5	66.04	-12.78	53.26	74	-20.74	peak	Vertical
2483.5	63.57	-12.78	50.79	74	-23.21	peak	Horizontal
802.11n (20)							
2390	63.83	-13.06	53.77	74	-20.23	peak	Vertical
2390	64.14	-13.06	51.08	74	-22.92	peak	Horizontal
2483.5	63.43	-12.78	53.65	74	-20.35	peak	Vertical
2483.5	66.76	-12.78	53.98	74	-20.02	peak	Horizontal
802.11n (40)							
2390	66.41	-13.06	53.35	74	-20.65	peak	Vertical
2390	66.24	-13.06	53.18	74	-20.82	peak	Horizontal
2483.5	66.71	-12.78	53.93	74	-20.07	peak	Vertical
2483.5	65.84	-12.78	53.06	74	-20.94	peak	Horizontal

Note: Test method to see chapter 3.2 . When PK value is lower than the Average value limit, average not record.

802.11b: Band Edge, Right Side

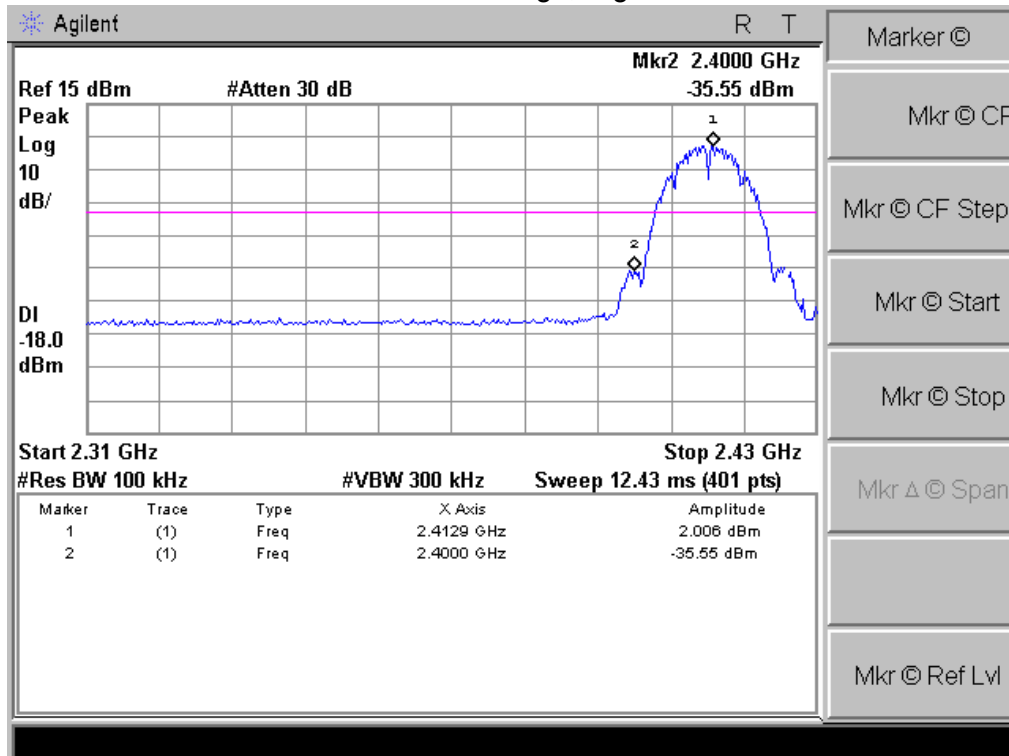

802.11b: Band Edge, Left Side

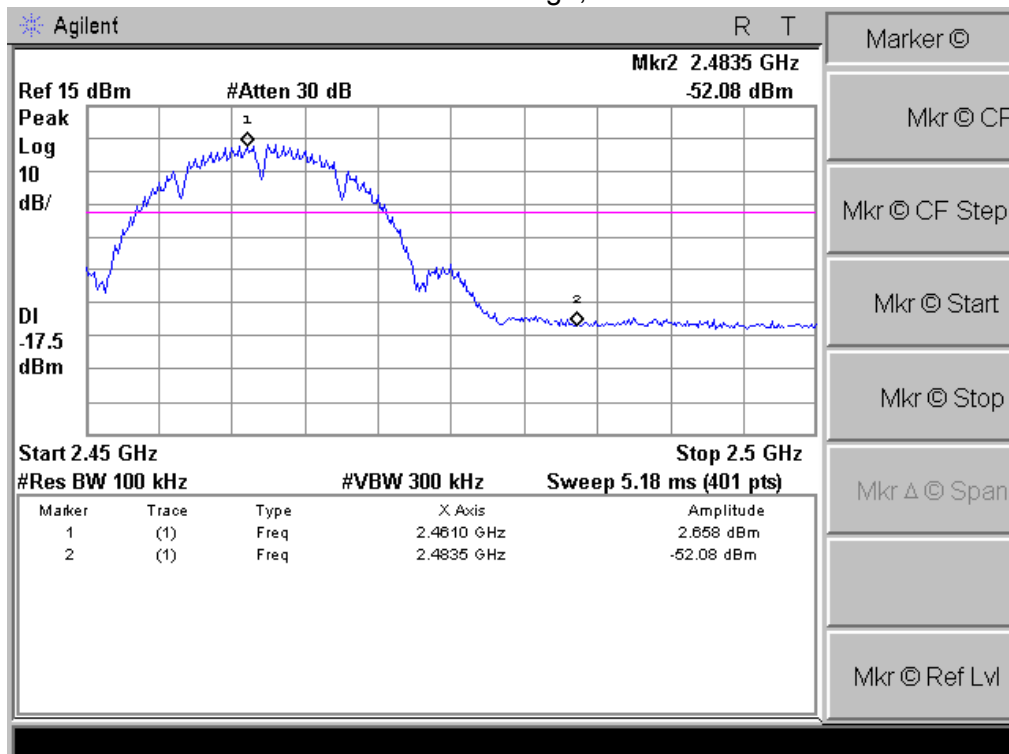

802.11g: Band Edge, Right Side

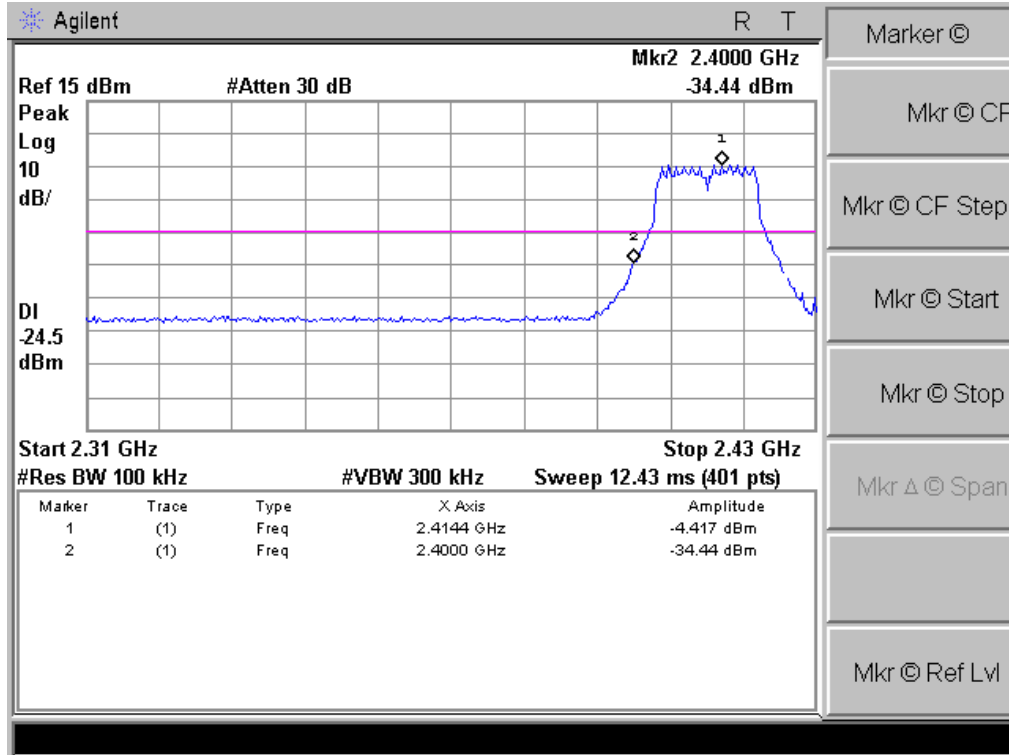

802.11g: Band Edge, Left Side

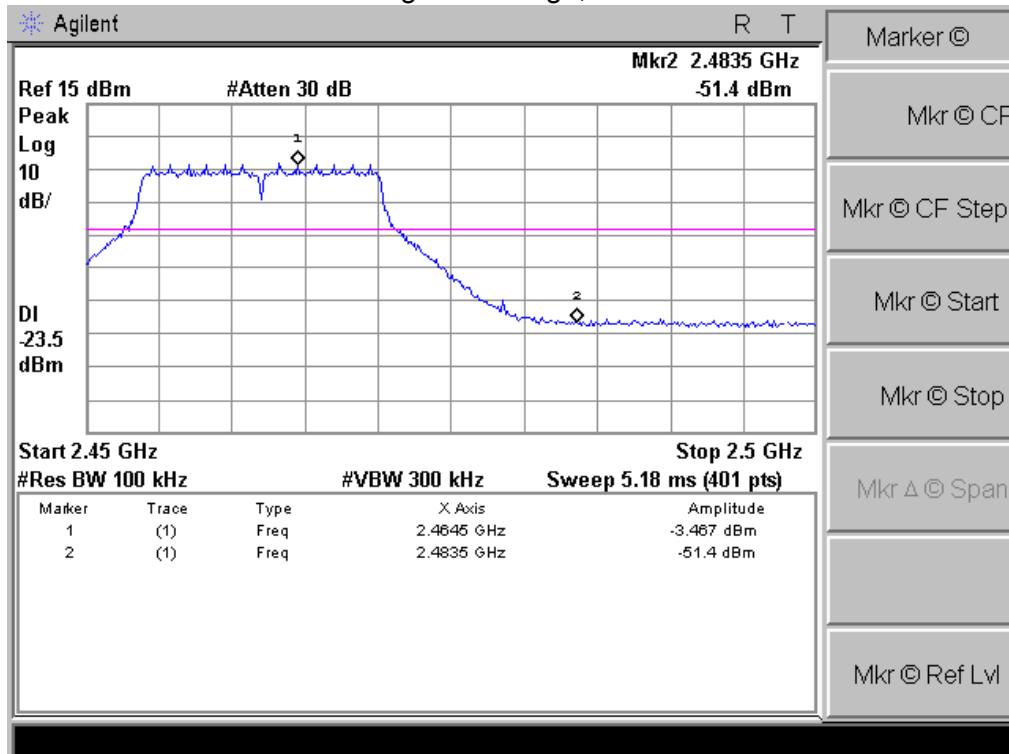

802.11n-HT20: Band Edge, Right Side

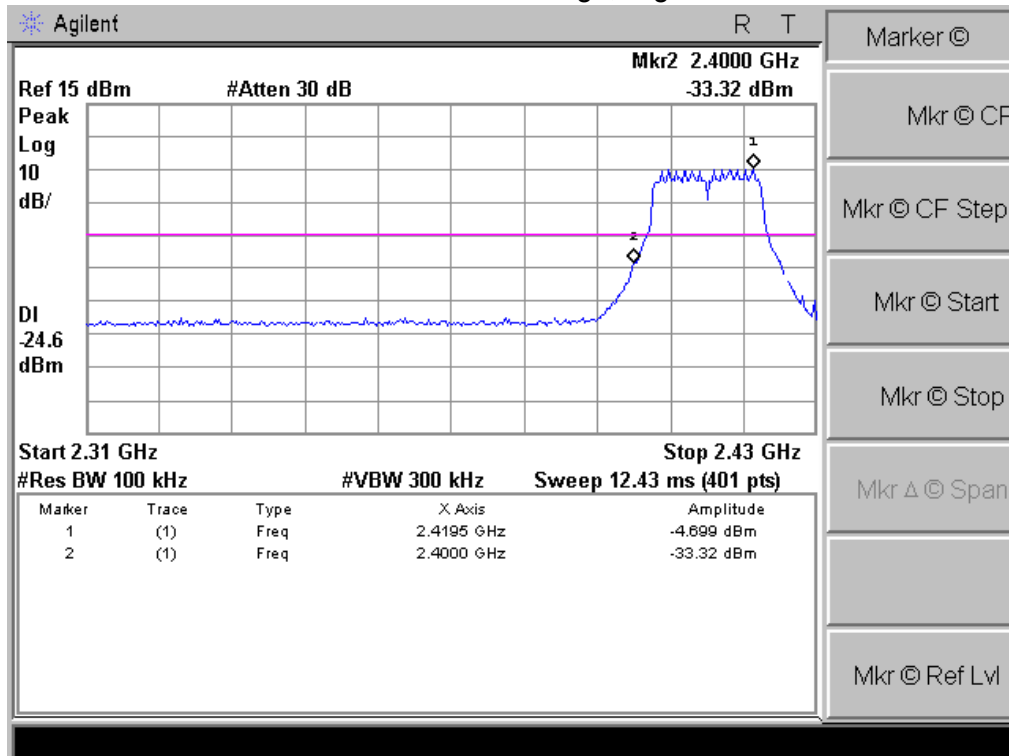

802.11n-HT20: Band Edge, Left Side

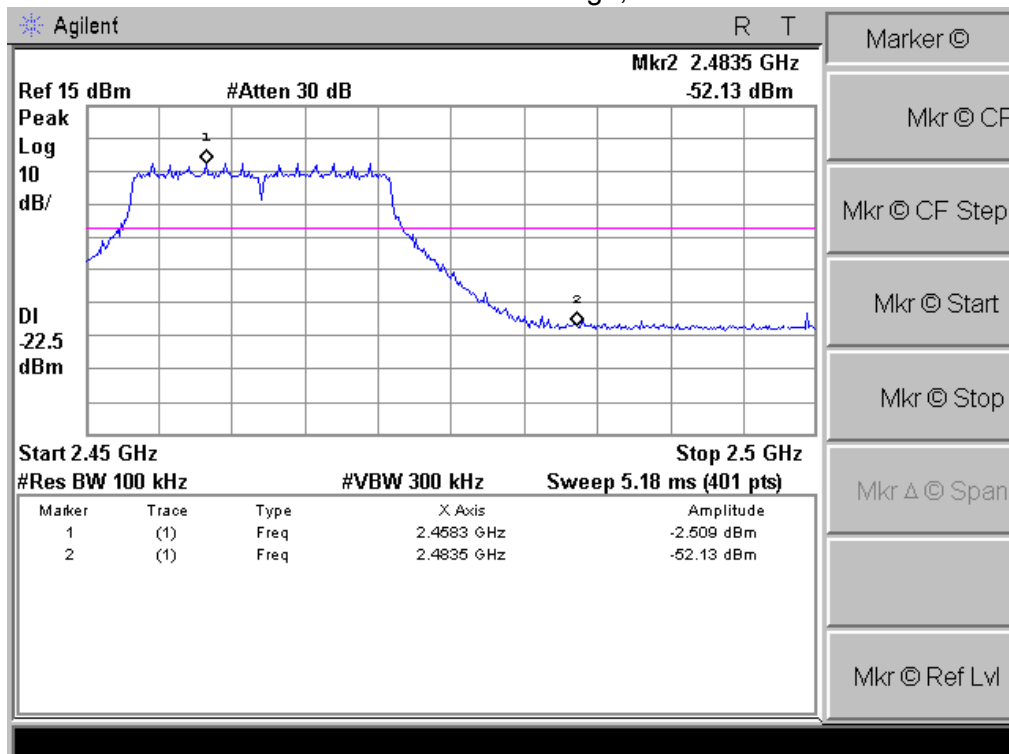

802.11n-HT40: Band Edge, Right Side

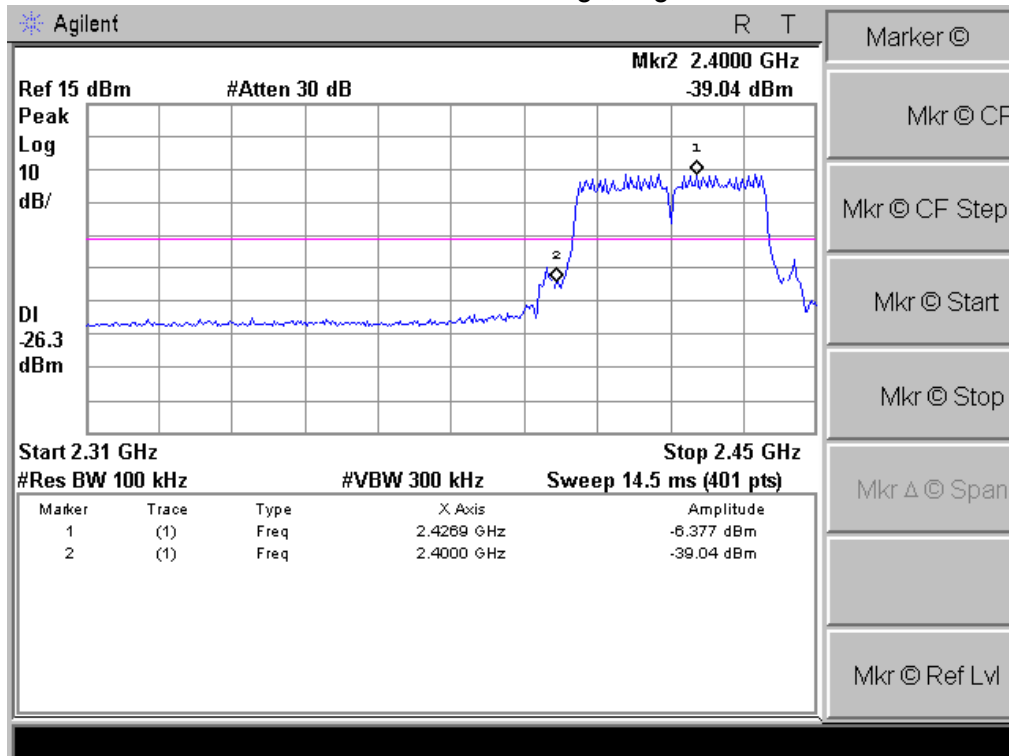

802.11n-HT40: Band Edge, Left Side

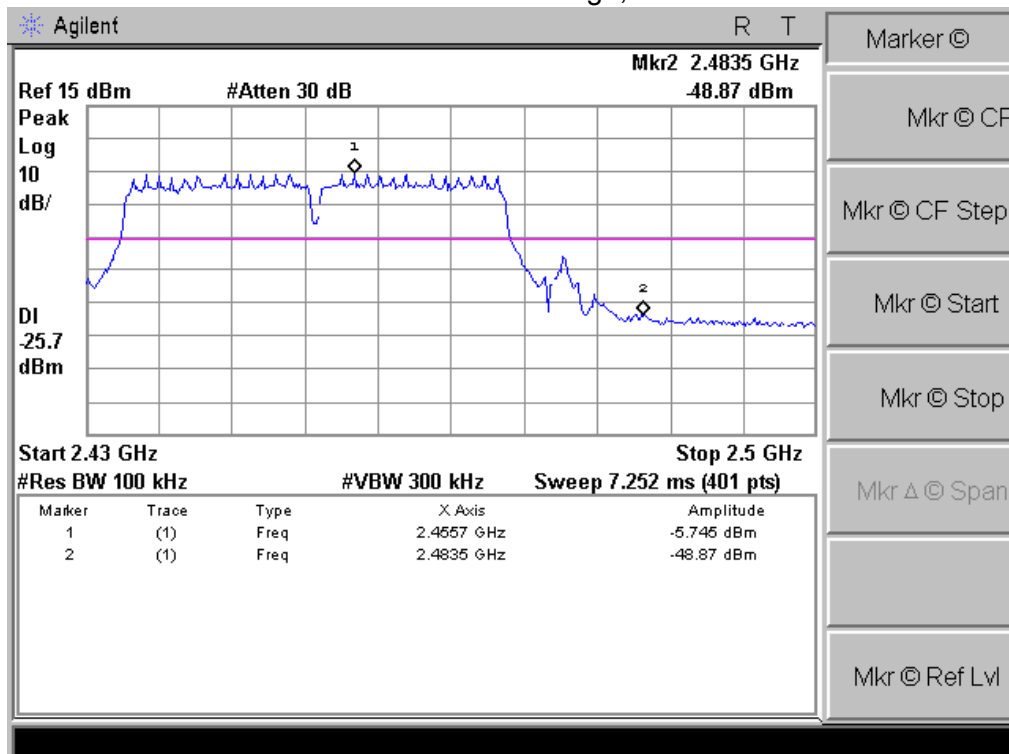

8. ANTENNA REQUIREMENT

8.1 STANDARD REQUIREMENT

15.203 requirement: For intentional device, according to 15.203: an intentional radiator shall be designed to ensure that no antenna other than that furnished by the responsible party shall be used with the device.

8.2 EUT ANTENNA

The EUT antenna is permanent attached antenna. It comply with the standard requirement.

9. EUT TEST PHOTO

Radiated Measurement Photos

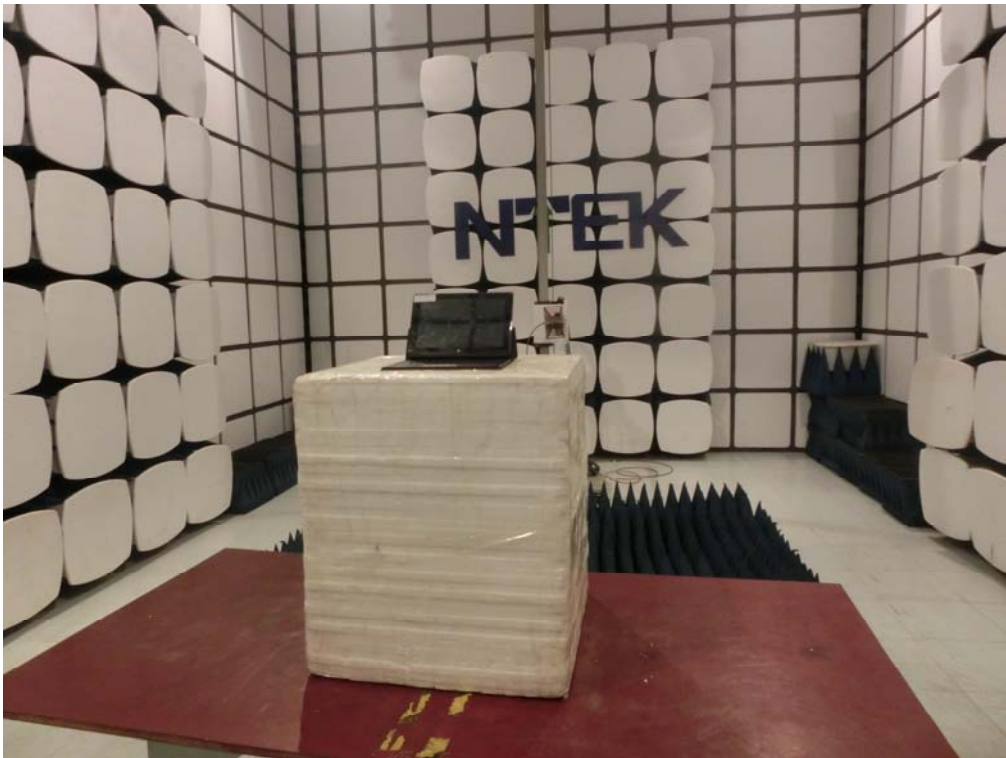
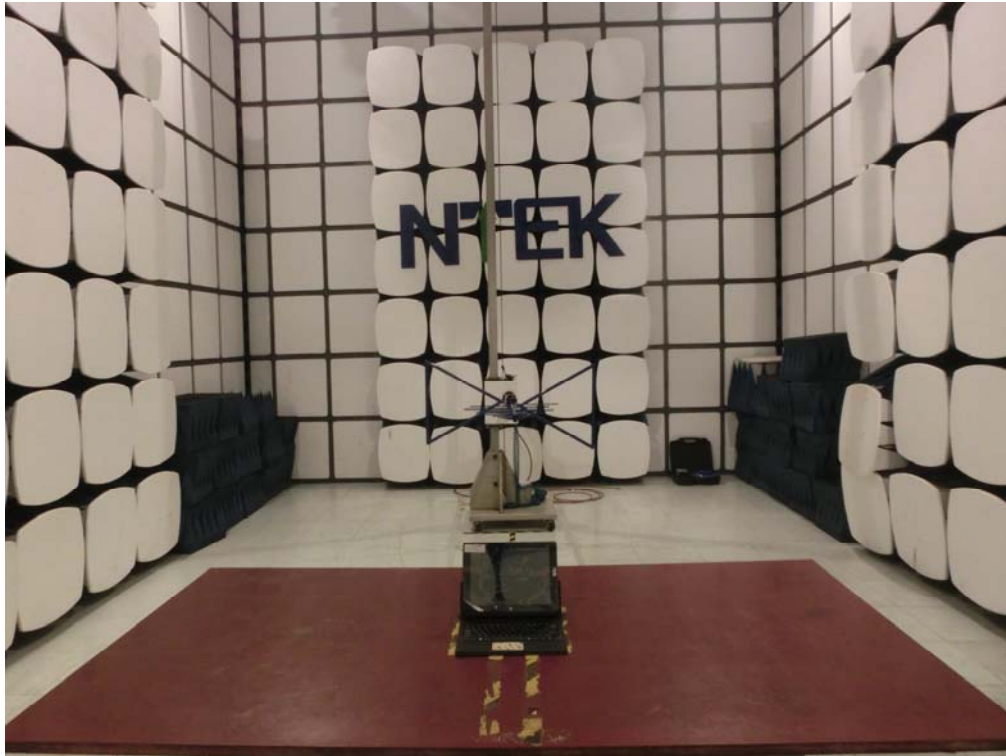

CONDUCTED EMISSION Photos

