

RADIO TEST REPORT

FCC ID: 2AFNZ-ETL815A

Product : VisDial X

Trade Mark : VitalASC

Model Name : ETL-815A

Family Model : N/A

Report No. : S19031903702001

Prepared for

JING MOLD ELECTRONICS TECHNOLOGY(SHENZHEN)CO.,LTD

Xinqiao,3rd Industrial Estate,Shajing Baoan,Shenzhen,China

Prepared by

Shenzhen NTEK Testing Technology Co., Ltd.

1/F, Building E, Fenda Science Park, Sanwei Community, Xixiang Street
Bao'an District, Shenzhen 518126 P.R. China

Tel.: +86-755-6115 9388 Fax.: +86-755-6115 6599

Website:<http://www.ntek.org.cn>

TEST RESULT CERTIFICATION

Applicant's name : JING MOLD ELECTRONICS TECHNOLOGY(SHENZHEN)CO.,LTD
Address : Xinqiao,3rd Industrial Estate,Shajing Baoan,Shenzhen,China
Manufacturer's Name : JING MOLD ELECTRONICS TECHNOLOGY(SHENZHEN)CO.,LTD
Address : Xinqiao,3rd Industrial Estate,Shajing Baoan,Shenzhen,China

Product description

Product name : VisDial X
Model and/or type reference : ETL-815A
Family Model : N/A
Rating(s) : DC 3.7V from battery or DC 5V from USB Port

Standards : FCC Part15.249

Test procedure : ANSI C63.10-2013

This device described above has been tested by NTEK, and the test results show that the equipment under test (EUT) is in compliance with the FCC requirements. And it is applicable only to the tested sample identified in the report.

This report shall not be reproduced except in full, without the written approval of NTEK, this document may be altered or revised by NTEK, personnel only, and shall be noted in the revision of the document.

Date of Test :
Date (s) of performance of tests : 22 Mar. 2019 ~07 Apr. 2019
Date of Issue : 10 Apr. 2019
Test Result : Pass

Testing Engineer : [Signature: Allen Liu]
(Allen Liu)

Technical Manager : [Signature: Jason Chen]
(Jason Chen)

Authorized Signatory : [Signature: Sam Chen]
(Sam Chen)

Table of Contents

Page

1 . SUMMARY OF TEST RESULTS	4
1.1 TEST FACILITY	5
1.2 MEASUREMENT UNCERTAINTY	5
2 . GENERAL INFORMATION	6
2.1 GENERAL DESCRIPTION OF EUT	6
2.2 DESCRIPTION OF TEST MODES	8
2.3 BLOCK DIGRAM SHOWING THE CONFIGURATION OF SYSTEM TESTED	9
2.4 DESCRIPTION OF SUPPORT UNITS(CONDUCTED MODE)	10
2.5 EQUIPMENTS LIST FOR ALL TEST ITEMS	11
3 . ANTENNA REQUIREMENT	13
3.1 STANDARD REQUIREMENT	13
3.2 EUT ANTENNA	13
3.3 CONDUCTED EMISSION MEASUREMENT	14
3.3.1 POWER LINE CONDUCTED EMISSION LIMITS	14
3.3.2 TEST PROCEDURE	15
3.3.3 DEVIATION FROM TEST STANDARD	15
3.3.4 TEST SETUP	15
3.2.5 TEST RESULT	16
3.4 RADIATED EMISSION MEASUREMENT	20
3.4.1 RADIATED EMISSION LIMITS	20
3.4.2 TEST PROCEDURE	21
3.4.3 DEVIATION FROM TEST STANDARD	21
3.4.4 TEST RESULTS (BELOW 30MHZ)	24
3.4.5 TEST RESULTS (BELOW 1000 MHZ)	25
3.4.6 TEST RESULTS (ABOVE 1000 MHZ)	27
3.4.7 TEST RESULTS (RESTRICTED BANDS REQUIREMENTS)	33
4 . FREQUENCY TOLERANCE	37
4.1 FREQUENCY TOLERANCE LIMITS	37
4.2TEST PROCEDURE	37
4.3 TEST SETUP	37
4.4 TEST RESULTS	37
5. BANDWIDTH TEST	39
5.1 TEST PROCEDURE	39
5.1 DEVIATION FROM STANDARD	39
5.1 TEST SETUP	39
6. TEST RESULTS	40

1. SUMMARY OF TEST RESULTS

Test procedures according to the technical standards:

FCC Part15, Subpart C (15.249)			
Standard Section	Test Item	Judgment	Remark
15.207	Conducted Emission	Pass	
15.203	Antenna Requirement	Pass	
15.249 15.209	Radiated Spurious Emission	Pass	
15.249(2)	Frequency Tolerance	Pass	
15.249(a)	Fundamental Measurement	Pass	
15.205	Band Edge Emission	Pass	
15.215	Occupied Bandwidth	Pass	

1.1 TEST FACILITY

Shenzhen NTEK Testing Technology Co., Ltd
 Add. : 1/F, Building E, Fenda Science Park, Sanwei Community, Xixiang Street, Bao'an District, Shenzhen 518126 P.R. China.
 FCC FRN Registration No.:463705; IC Registration No.:9270A-1
 CNAS Registration No.:L5516

1.2 MEASUREMENT UNCERTAINTY

The reported uncertainty of measurement $y \pm U$, where expanded uncertainty U is based on a standard uncertainty multiplied by a coverage factor of $k=2$, providing a level of confidence of approximately **95 %**.

No.	Item	Uncertainty
1	Conducted Emission Test	$\pm 1.38\text{dB}$
2	RF power,conducted	$\pm 0.16\text{dB}$
3	Spurious emissions,conducted	$\pm 0.21\text{dB}$
4	All emissions,radiated(<1G)	$\pm 4.68\text{dB}$
5	All emissions,radiated(>1G)	$\pm 4.89\text{dB}$
6	Temperature	$\pm 0.5^\circ\text{C}$
7	Humidity	$\pm 2\%$

2. GENERAL INFORMATION

2.1 GENERAL DESCRIPTION OF EUT

Equipment	VisDial X
Trade Mark	VitalASC
Model Name	ETL-815A
Family Model	N/A
Model Difference	N/A
Product Description	The EUT is a VisDial X
	Operation Frequency: 2406-2475MHz
	Modulation Type: GFSK
	Antenna Designation: PCB Antenna
	Antenna Gain(Peak) -3.02 dBi
Based on the application, features, or specification exhibited in User's Manual. More details of EUT technical specification, please refer to the User's Manual.	
Channel List	Please refer to the Note 2.
Adapter	N/A
Battery	DC 3.7V, 450mAh
HW Version	ETL-815A-MB RF VER1.1
SW Version	ETL-815A DT_0109

Note:

1. For a more detailed features description, please refer to the manufacturer's specifications or the User's Manual.

2.

Channel	Frequency(MHz)
01	2406
02	2407
...	...
34	2439
35	2440
...	...
69	2474
70	2475

3.

Table for Filed Antenna

Ant.	Brand	Model Name	Antenna Type	Connector	Gain (dBi)	NOTE
1	N/A	N/A	PCB Antenna	N/A	-3.02	Antenna

2.2 DESCRIPTION OF TEST MODES

To investigate the maximum EMI emission characteristics generates from EUT, the test system was pre-scanning tested base on the consideration of following EUT operation mode or test configuration mode which possible have effect on EMI emission level. Each of these EUT operation mode(s) or test configuration mode(s) mentioned above was evaluated respectively.

Pretest Mode	Description
Mode 1	CH01
Mode 2	CH34
Mode 3	CH70
Mode 4	Normal link

For Radiated Spurious Emission

Pretest Mode	Description
Mode 1	CH01
Mode 2	CH34
Mode 3	CH70

For Conducted Emission

Final Test Mode	Description
Mode 1	CH01
Mode 2	CH34
Mode 3	CH70
Mode 4	Normal link

Note:

(1) The measurements are performed at the highest, middle, lowest available channels.

2.3 BLOCK DIGRAM SHOWING THE CONFIGURATION OF SYSTEM TESTED

Conducted Emission Mode

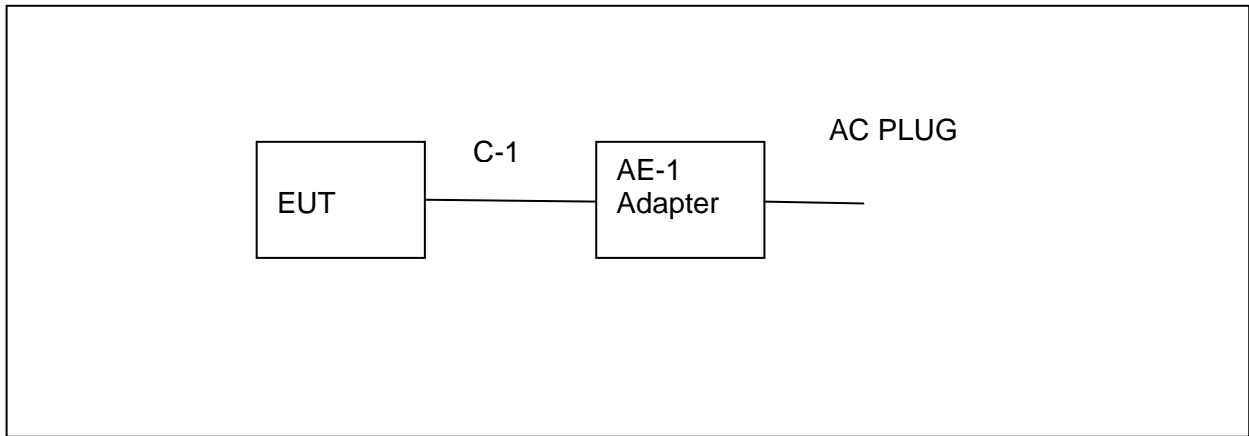

Radiated Spurious Emission Test

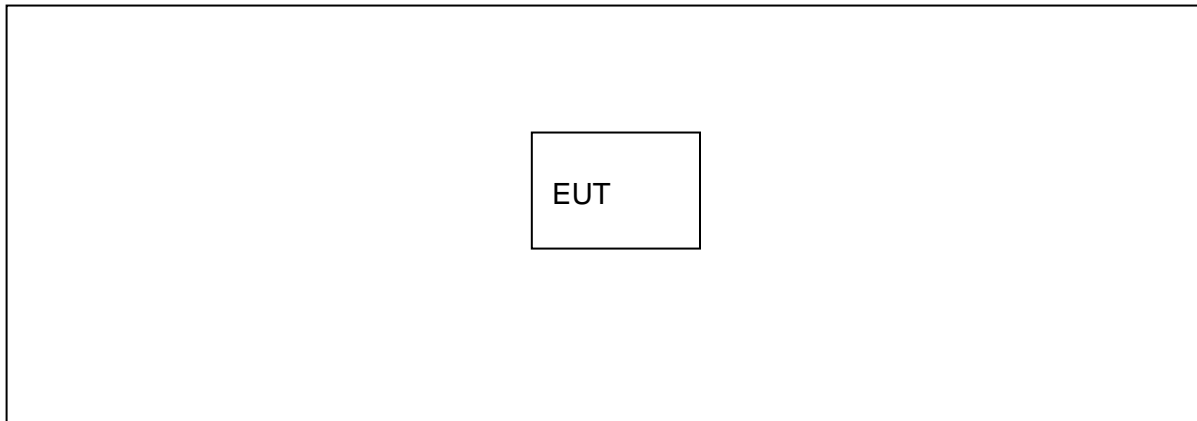

2.4 DESCRIPTION OF SUPPORT UNITS(CONDUCTED MODE)

The EUT has been tested as an independent unit together with other necessary accessories or support units. The following support units or accessories were used to form a representative test configuration during the tests.

Item	Equipment	Mfr/Brand	Model/Type No.	Series No.	Note
AE-1	Adapter	SIMP	KSAPK0110500200D5	N/A	Peripherals

Item	Cable Type	Shielded Type	Ferrite Core	Length	Note
C-1	USB Cable	NO	NO	0.5m	

Note:

- (1) The support equipment was authorized by Declaration of Confirmation.
- (2) For detachable type I/O cable should be specified the length in cm in 『Length』 column.

2.5 EQUIPMENTS LIST FOR ALL TEST ITEMS

Radiation Test equipment

Item	Kind of Equipment	Manufacturer	Type No.	Serial No.	Last calibration	Calibrated until	Calibration period
1	Spectrum Analyzer	Agilent	E4407B	MY45108040	2018.05.19	2019.05.18	1 year
2	Spectrum Analyzer	Agilent	N9020A	MY49100060	2018.10.08	2019.10.07	1 year
3	EMI Test Receiver	Agilent	N9038A	MY53227146	2018.05.19	2019.05.18	1 year
4	Test Receiver	R&S	ESPI	101318	2018.05.19	2019.05.18	1 year
5	Bilog Antenna	TESEQ	CBL6111D	31216	2018.04.08	2019.04.07	1 year
6	50Ω Coaxial Switch	Anritsu	MP59B	6200983705	2018.05.19	2019.05.18	1 year
7	Horn Antenna	EM	EM-AH-10180	2011071402	2018.04.08	2019.04.07	1 year
8	Horn Ant	Schwarzbeck	BBHA 9170	9170-181	2018.12.11	2019.12.10	1 year
9	Amplifier	EMC	EMC051835SE	980246	2018.08.05	2019.08.04	1 year
10	Amplifier	MITEQ	TTA1840-35-HG	177156	2018.05.19	2019.05.18	1 year
11	Loop Antenna	ARA	PLA-1030/B	1029	2018.05.19	2019.05.18	1 year
12	Power Meter	DARE	RPR3006W	15I00041S NO84	2018.08.05	2019.08.04	1 year
13	Test Cable (9KHz-30MHz)	N/A	R-01	N/A	2017.04.21	2020.04.20	3 year
14	Test Cable (30MHz-1GHz)	N/A	R-02	N/A	2017.04.21	2020.04.20	3 year
15	High Test Cable(1G-40GHz)	N/A	R-03	N/A	2017.04.21	2020.04.20	3 year
16	High Test Cable(1G-40GHz)	N/A	R-04	N/A	2017.04.21	2020.04.20	3 year
17	temporary antenna connector (Note)	NTS	R001	N/A	N/A	N/A	N/A

Note:

We will use the temporary antenna connector (soldered on the PCB board) When conducted test
And this temporary antenna connector is listed within the instrument list

Conduction Test equipment

Item	Kind of Equipment	Manufacturer	Type No.	Serial No.	Last calibration	Calibrated until	Calibration period
1	Test Receiver	R&S	ESCI	101160	2018.05.19	2019.05.18	1 year
2	LISN	R&S	ENV216	101313	2018.04.09	2019.04.08	1 year
3	LISN	SCHWARZBECK	NNLK 8129	8129245	2018.05.19	2019.05.18	1 year
4	50Ω Coaxial Switch	ANRITSU CORP	MP59B	6200983704	2018.05.19	2019.05.18	1 year
5	Test Cable (9KHz-30MHz)	N/A	C01	N/A	2017.04.21	2020.04.20	3 year
6	Test Cable (9KHz-30MHz)	N/A	C02	N/A	2017.04.21	2020.04.20	3 year
7	Test Cable (9KHz-30MHz)	N/A	C03	N/A	2017.04.21	2020.04.20	3 year

Note: Each piece of equipment is scheduled for calibration once a year except the Test Cable which is scheduled for calibration every 3 years.

3. ANTENNA REQUIREMENT

3.1 STANDARD REQUIREMENT

15.203 requirement: For intentional device, according to 15.203: an intentional radiator shall be designed to ensure that no antenna other than that furnished by the responsible party shall be used with the device.

3.2 EUT ANTENNA

The EUT antenna is permanent attached PCB antenna (Gain:-3.02dBi). It comply with the standard requirement.

3.3 CONDUCTED EMISSION MEASUREMENT

3.3.1 POWER LINE CONDUCTED EMISSION Limits (Frequency Range 150KHz-30MHz)

Frequency(MHz)	Conducted Emission Limit	
	Quasi-peak	Average
0.15-0.5	66-56*	56-46*
0.5-5.0	56	46
5.0-30.0	60	50

Note: 1. *Decreases with the logarithm of the frequency
 2. The lower limit shall apply at the transition frequencies
 3. The limit decreases in line with the logarithm of the frequency in the range of 0.15 to 0.50MHz.

The following table is the setting of the receiver

Receiver Parameters	Setting
Attenuation	10 dB
Start Frequency	0.15 MHz
Stop Frequency	30 MHz
IF Bandwidth	9 kHz

3.3.2 TEST PROCEDURE

- a. The EUT was placed 0.4 meters from the horizontal ground plane with EUT being connected to the power mains through a line impedance stabilization network (LISN). All other support equipments powered from additional LISN(s). The LISN provide 50 Ohm/ 50uH of coupling impedance for the measuring instrument.
- b. Interconnecting cables that hang closer than 40 cm to the ground plane shall be folded back and forth in the center forming a bundle 30 to 40 cm long.
- c. I/O cables that are not connected to a peripheral shall be bundled in the center. The end of the cable may be terminated, if required, using the correct terminating impedance. The overall length shall not exceed 1 m.
- d. LISN at least 80 cm from nearest part of EUT chassis.
- e. For the actual test configuration, please refer to the related Item –EUT Test Photos.

3.3.3 DEVIATION FROM TEST STANDARD

No deviation

3.3.4 TEST SETUP

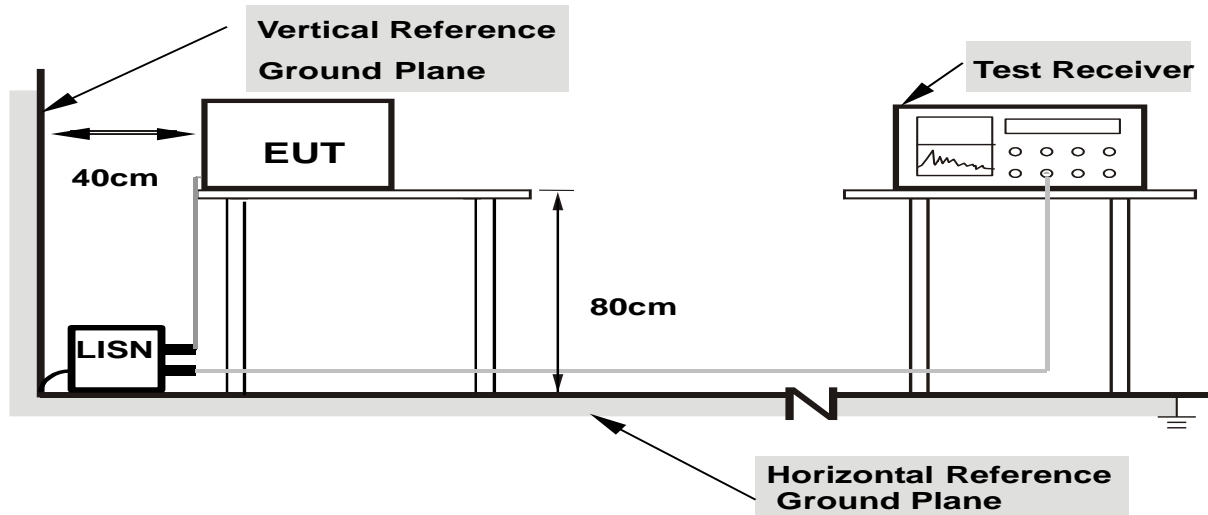

- Note:**
- 1.Support units were connected to second LISN.
 - 2.Both of LISNs (AMN) are 80 cm from EUT and at least 80 from other units and other metal planes

3.2.5 TEST RESULT

EUT :	VisDial X	Model Name. :	ETL-815A
Temperature :	25 °C	Relative Humidity :	55%
Pressure :	1010hPa	Phase :	L
Test Voltage :	DC 5V from adapter AC 120V/60Hz	Test Mode :	Model 4

Frequency (MHz)	Reading Level (dBμV)	Correct Factor (dB)	Measure-ment (dBμV)	Limits (dBμV)	Margin (dB)	Remark
0.1620	36.04	9.76	45.80	65.36	-19.56	QP
0.1620	19.26	9.76	29.02	55.36	-26.34	AVG
0.1900	30.86	9.76	40.62	64.03	-23.41	QP
0.1900	17.69	9.76	27.45	54.03	-26.58	AVG
0.4980	33.36	9.74	43.10	56.03	-12.93	QP
0.4980	21.10	9.74	30.84	46.03	-15.19	AVG
0.7660	24.80	9.74	34.54	56.00	-21.46	QP
0.7660	16.14	9.74	25.88	46.00	-20.12	AVG
0.9780	25.34	9.74	35.08	56.00	-20.92	QP
0.9780	14.80	9.74	24.54	46.00	-21.46	AVG
2.8500	19.23	9.82	29.05	56.00	-26.95	QP
2.8500	7.67	9.82	17.49	46.00	-28.51	AVG

Remark:

1. All readings are Quasi-Peak and Average values.
2. Factor = Insertion Loss + Cable Loss.

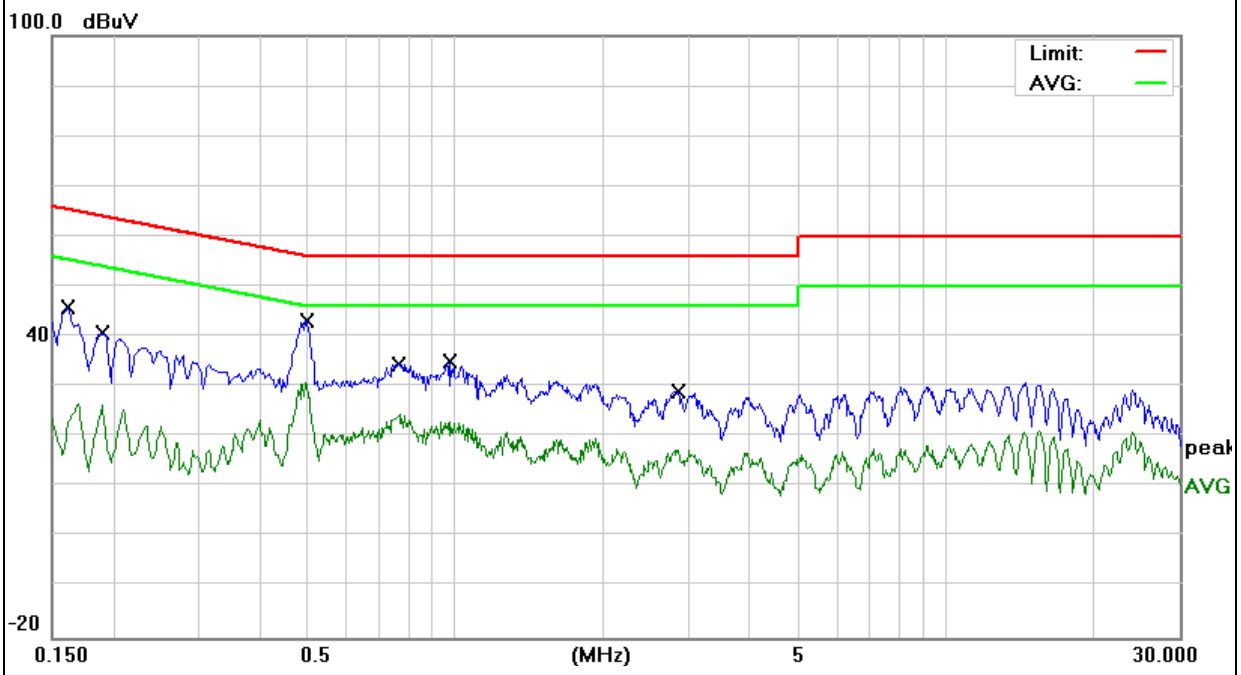

EUT :	VisDial X	Model Name. :	ETL-815A
Temperature :	25 °C	Relative Humidity :	55%
Pressure :	1010hPa	Phase :	N
Test Voltage :	DC 5V from adapter AC 120V/60Hz	Test Mode :	Model 4

Frequency (MHz)	Reading Level (dBμV)	Correct Factor (dB)	Measurement (dBμV)	Limits (dBμV)	Margin (dB)	Remark
0.1524	34.72	9.75	44.47	65.86	-21.39	QP
0.1524	19.27	9.75	29.02	55.86	-26.84	AVG
0.1700	33.33	9.76	43.09	64.96	-21.87	QP
0.1700	23.28	9.76	33.04	54.96	-21.92	AVG
0.4900	33.26	9.74	43.00	56.17	-13.17	QP
0.4900	25.61	9.74	35.35	46.17	-10.82	AVG
0.7660	22.48	9.74	32.22	56.00	-23.78	QP
0.7660	15.38	9.74	25.12	46.00	-20.88	AVG
1.3700	21.33	9.75	31.08	56.00	-24.92	QP
1.3700	13.00	9.75	22.75	46.00	-23.25	AVG
11.1500	16.52	10.03	26.55	60.00	-33.45	QP
11.1500	8.11	10.03	18.14	50.00	-31.86	AVG

Remark:

1. All readings are Quasi-Peak and Average values.
2. Factor = Insertion Loss + Cable Loss.

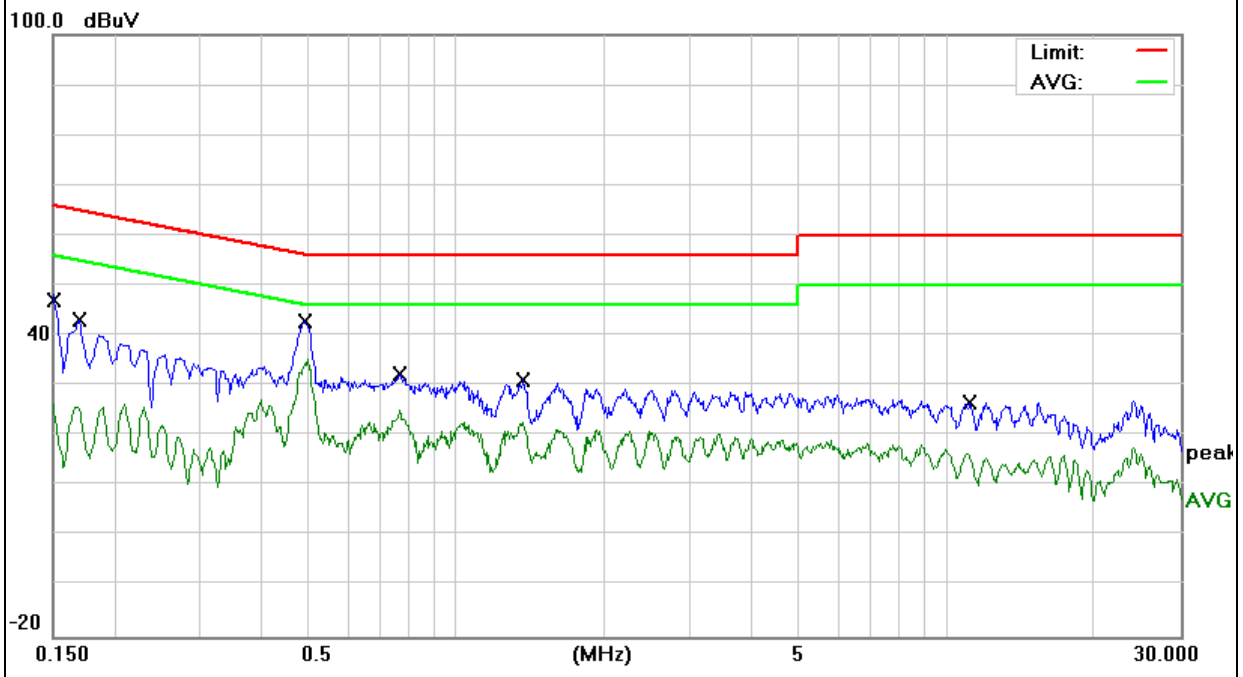

EUT :	VisDial X	Model Name. :	ETL-815A
Temperature :	25 °C	Relative Humidity :	55%
Pressure :	1010hPa	Phase :	L
Test Voltage :	DC 5V from adapter AC 240V/60Hz	Test Mode :	Model 4

Frequency (MHz)	Reading Level (dBμV)	Correct Factor (dB)	Measurement (dBμV)	Limits (dBμV)	Margin (dB)	Remark
0.1660	29.66	9.76	39.42	65.15	-25.73	QP
0.1660	17.39	9.76	27.15	55.15	-28.00	AVG
0.5060	32.43	9.74	42.17	56.00	-13.83	QP
0.5060	20.12	9.74	29.86	46.00	-16.14	AVG
0.8820	28.05	9.74	37.79	56.00	-18.21	QP
0.8820	16.22	9.74	25.96	46.00	-20.04	AVG
1.4740	25.21	9.76	34.97	56.00	-21.03	QP
1.4740	15.68	9.76	25.44	46.00	-20.56	AVG
2.0140	24.53	9.78	34.31	56.00	-21.69	QP
2.0140	14.91	9.78	24.69	46.00	-21.31	AVG
2.6700	22.79	9.80	32.59	56.00	-23.41	QP
2.6700	9.74	9.80	19.54	46.00	-26.46	AVG

Remark:

1. All readings are Quasi-Peak and Average values.
2. Factor = Insertion Loss + Cable Loss.

100.0 dBuV

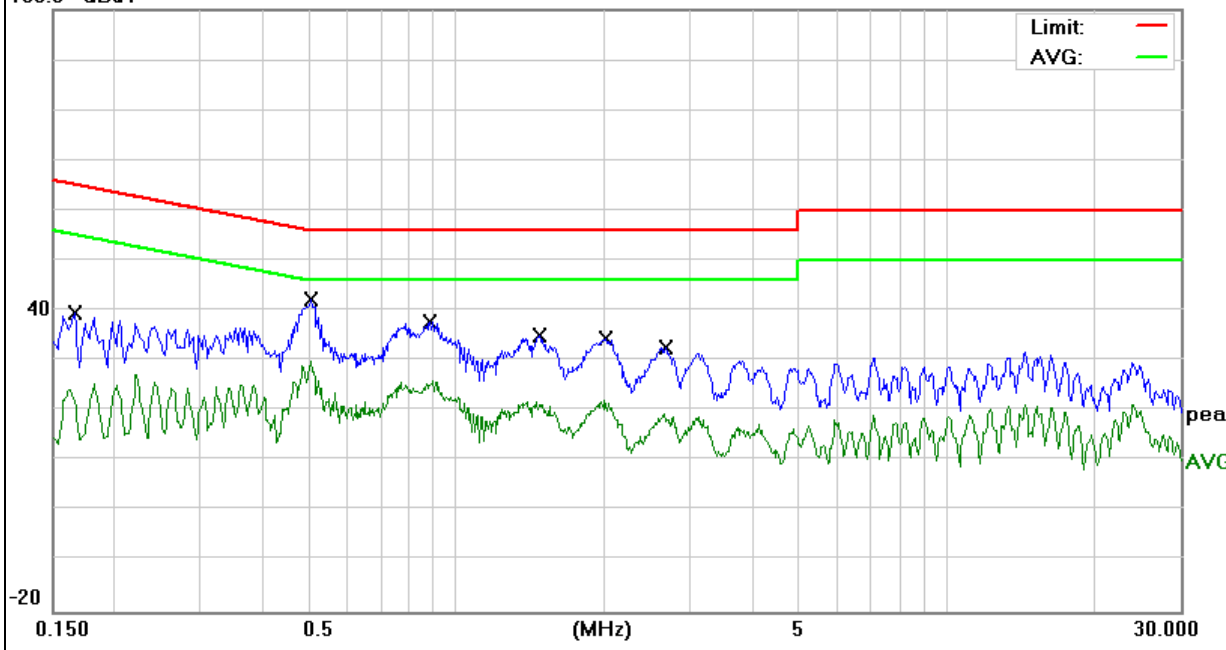

EUT :	VisDial X	Model Name. :	ETL-815A
Temperature :	25 °C	Relative Humidity :	55%
Pressure :	1010hPa	Phase :	N
Test Voltage :	DC 5V from adapter AC 240V/60Hz	Test Mode :	Model 4

Frequency (MHz)	Reading Level (dBμV)	Correct Factor (dB)	Measure-ment (dBμV)	Limits (dBμV)	Margin (dB)	Remark
0.5100	32.06	9.75	41.81	56.00	-14.19	QP
0.5100	24.48	9.75	34.23	46.00	-11.77	AVG
0.8780	26.39	9.75	36.14	56.00	-19.86	QP
0.8780	18.23	9.75	27.98	46.00	-18.02	AVG
1.4900	25.13	9.77	34.90	56.00	-21.10	QP
1.4900	15.56	9.77	25.33	46.00	-20.67	AVG
1.9540	24.31	9.79	34.10	56.00	-21.90	QP
1.9540	16.66	9.79	26.45	46.00	-19.55	AVG
2.5900	23.63	9.83	33.46	56.00	-22.54	QP
2.5900	17.29	9.83	27.12	46.00	-18.88	AVG
3.1700	23.26	9.88	33.14	56.00	-22.86	QP
3.1700	15.87	9.88	25.75	46.00	-20.25	AVG

Remark:

1. All readings are Quasi-Peak and Average values.
2. Factor = Insertion Loss + Cable Loss.

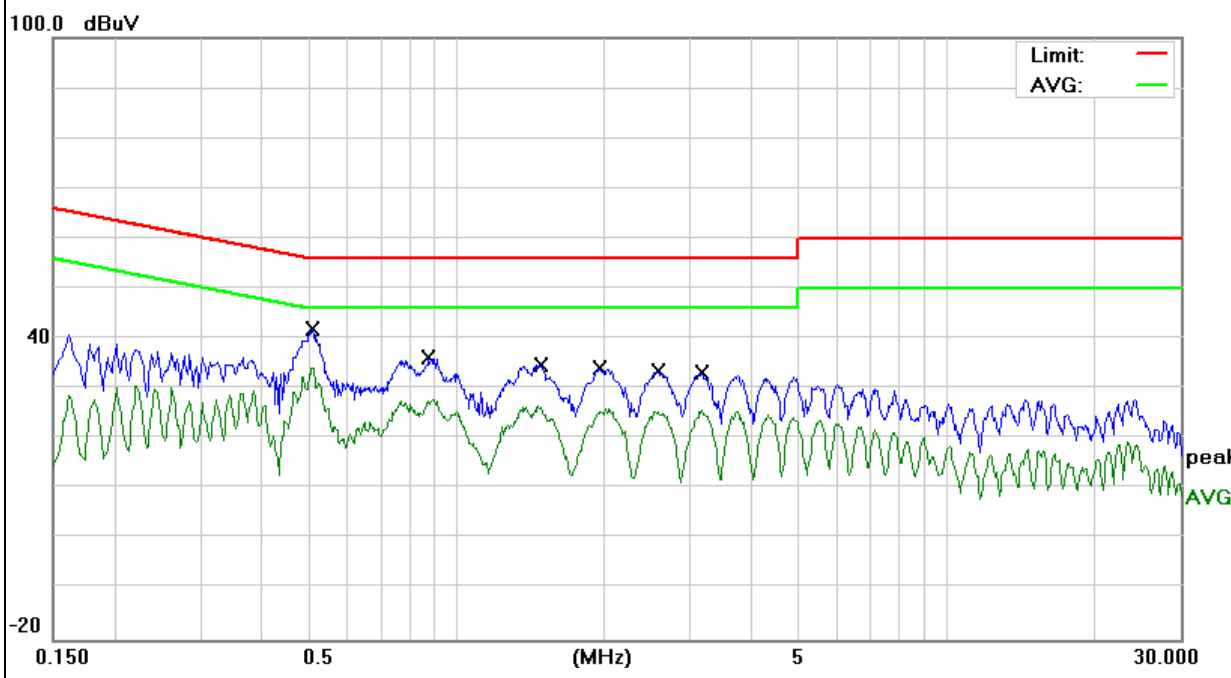

3.4 RADIATED EMISSION MEASUREMENT

3.4.1 Radiated Emission Limits (FCC 15.209)

Frequencies (MHz)	Field Strength (micorvolts/meter)	Measurement Distance (meters)
0.009~0.490	2400/F(KHz)	300
0.490~1.705	24000/F(KHz)	30
1.705~30.0	30	30
Frequency (MHz)	Limit (dBuV)	
30~88	40	3
88~216	43.5	3
216~960	46	3
960 -10000	54.00	3
*902 - 928	94.00	3

Note:

- (1) The tighter limit applies at the band edges.
- (2) Emission level (dBuV/m)=20log Emission level (uV/m).
- (3) *Note: This is the limit for the fundamental frequency.

LIMITS OF RADIATED EMISSION MEASUREMENT (FCC 15.249)

Frequency of Emission (MHz)	Field Strength of fundamental ((millivolts /meter)	Field Strength of Harmonics (microvolts/meter)
2400-2483.5	50	500

Notes:

- (1) Emissions radiated outside of the specified frequency bands, except for harmonics, shall be attenuated by at least 50 dB below the level of the fundamental or to the general radiated emission limits in Section 15.209, whichever is the lesser attenuation.

Spectrum Parameter	Setting
Attenuation	Auto
Start Frequency	1000 MHz
Stop Frequency	10th carrier harmonic
RB / VB (emission in restricted band)	1MHz / 1MHz for Peak

Receiver Parameter	Setting
Attenuation	Auto
Start ~ Stop Frequency	9kHz~150kHz / RB 200Hz for QP
Start ~ Stop Frequency	150kHz~30MHz / RB 9kHz for QP
Start ~ Stop Frequency	30MHz~1000MHz / RB 120kHz for QP

3.4.2 TEST PROCEDURE

- a. The measuring distance of at 3 m shall be used for measurements at frequency up to 1GHz. For frequencies above 1GHz, any suitable measuring distance may be used.
- b. The EUT was placed on the top of a rotating table 0.8 m for below 1GHz and 1.5m for above 1GHz the ground at a 3 meter. The table was rotated 360 degrees to determine the position of the highest radiation.
- c. The height of the equipment or of the substitution antenna shall be 0.8 m for below 1GHz and 1.5m for above 1GHz; the height of the test antenna shall vary between 1 m to 4 m. Both horizontal and vertical polarizations of the antenna are set to make the measurement.
- d. The initial step in collecting conducted emission data is a spectrum analyzer peak detector mode pre-scanning the measurement frequency range. Significant peaks are then marked and then Quasi Peak detector mode re-measured.
- e. If the Peak Mode measured value compliance with and lower than Quasi Peak Mode Limit, the EUT shall be deemed to meet QP Limits and then no additional QP Mode measurement performed.
- f. For the actual test configuration, please refer to the related Item –EUT Test Photos.

Note:

Both horizontal and vertical antenna polarities were tested and performed pretest to three orthogonal axis. The worst case emissions were reported

3.4.3 DEVIATION FROM TEST STANDARD

No deviation

(A) Radiated Emission Test-Up Frequency Below 30MHz

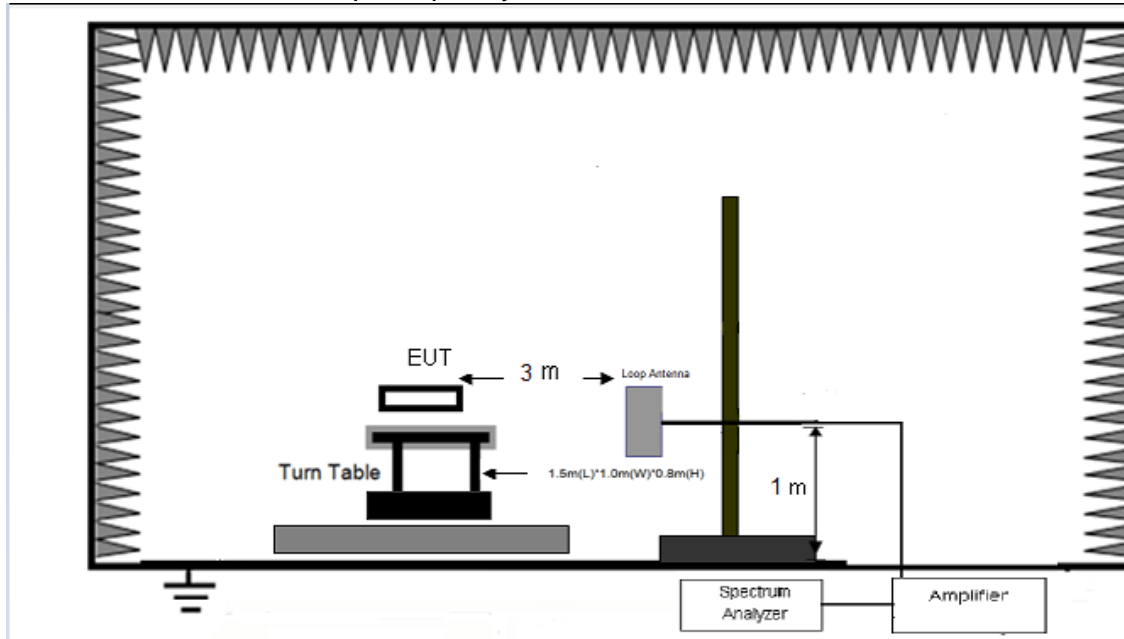

(B) Radiated Emission Test-Up Frequency 30MHz~1GHz

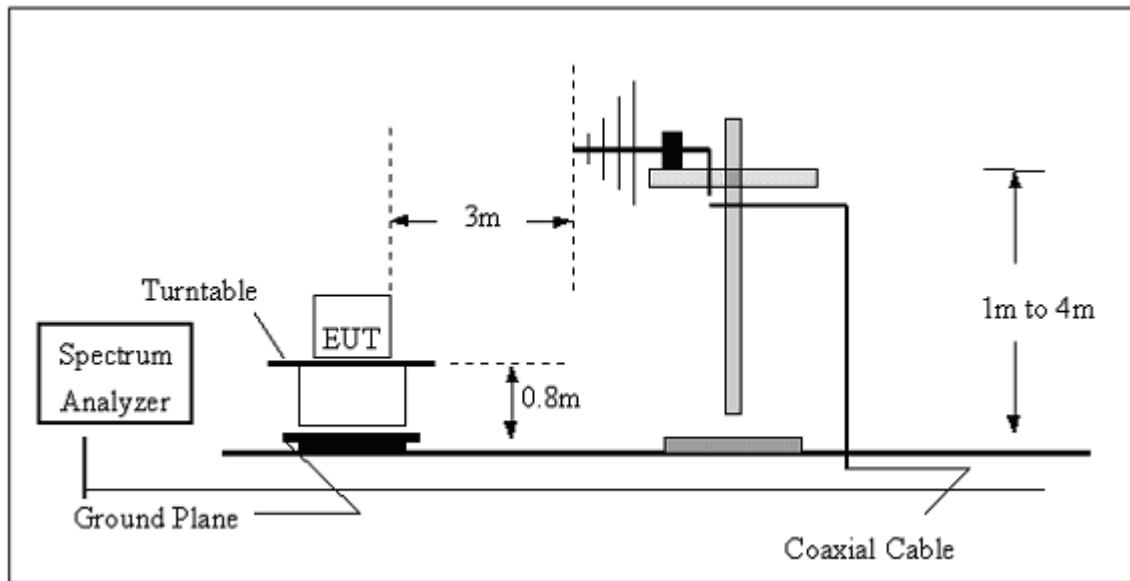

(C) Radiated Emission Test-Up Frequency Above 1GHz

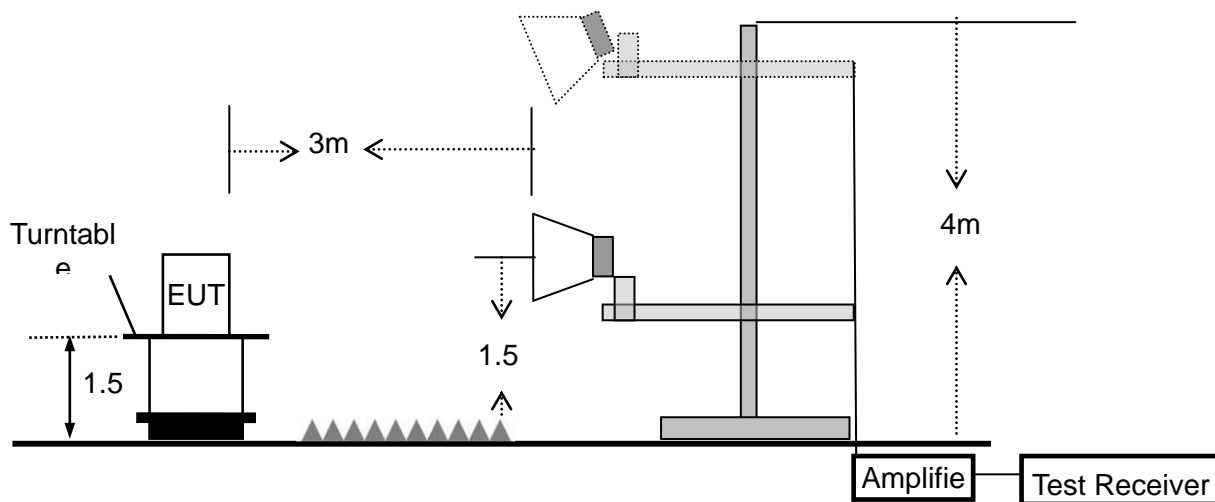

3.4.4 TEST RESULTS (BELOW 30MHz)

EUT :	VisDial X	Model Name. :	ETL-815A
Temperature :	20 °C	Relative Humidity :	48%
Pressure :	1010 hPa	Test Voltage :	DC 3.7V from battery
Test Mode :	TX	Polarization :	--

Freq.	Reading	Limit	Margin	State
(MHz)	(dBuV/m)	(dBuV/m)	(dB)	P/F
--	--	--	--	PASS
--	--	--	--	PASS

NOTE:

The amplitude of spurious emissions which are attenuated by more than 20dB below the permissible value has no need to be reported.

Distance extrapolation factor = $20 \log(\text{specific distance}/\text{test distance})$ (dB);

Limit line = specific limits(dBuv) + distance extrapolation factor.

3.4.5 TEST RESULTS (BELOW 1000 MHz)

EUT :	VisDial X	Model Name :	ETL-815A
Temperature :	25 °C	Relative Humidity :	51%
Pressure :	1010 hPa	Test Voltage :	DC 3.7V from battery
Test Mode :	Model 1	Polarization :	Vertical

Frequency (MHz)	Meter Reading (dBμV)	Factor (dB)	Emission Level (dBμV/m)	Limits (dBμV/m)	Margin (dB)	Detector Type
41.2765	14.45	13.99	28.44	40.00	-11.56	QP
50.2324	12.40	9.69	22.09	40.00	-17.91	QP
109.7959	25.12	10.45	35.57	43.50	-7.93	QP
128.1129	24.22	10.98	35.20	43.50	-8.30	QP
231.7178	26.01	10.92	36.93	46.00	-9.07	QP
317.7010	16.22	13.26	29.48	46.00	-16.52	QP

Remark:
Factor = Antenna Factor + Cable Loss – Pre-amplifier.
Factor Including Cable loss and antenna coefficient

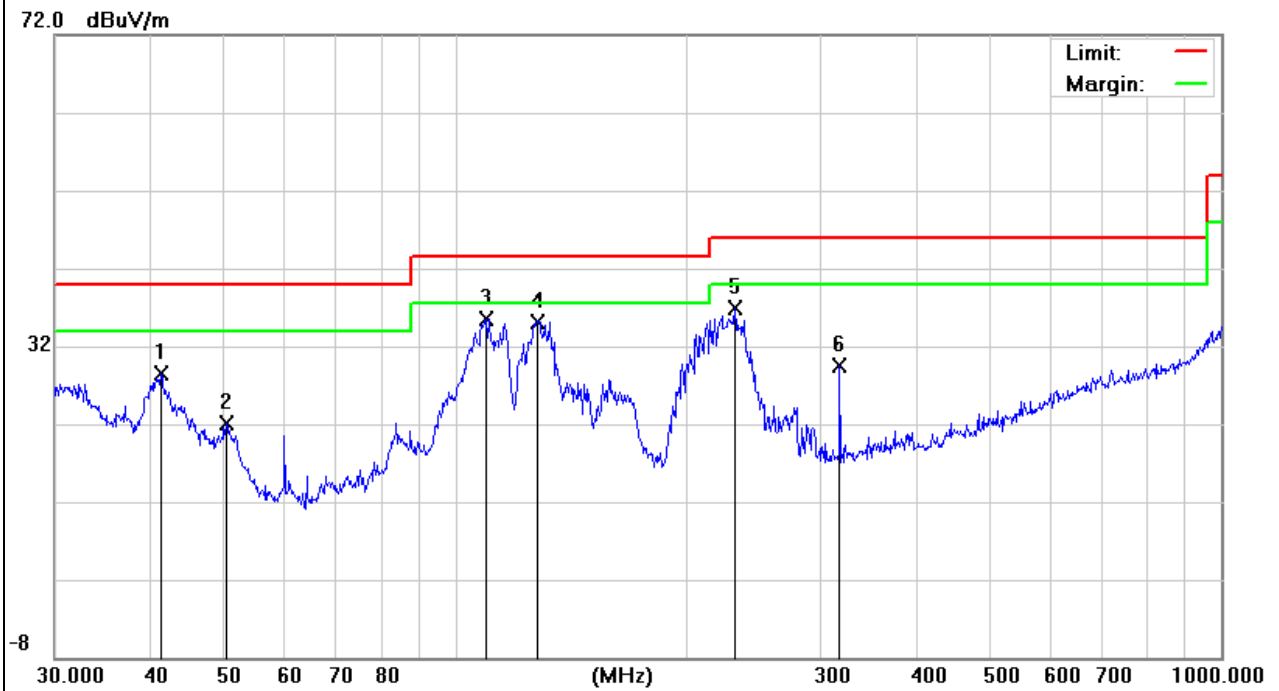

EUT :	VisDial X	Model Name :	ETL-815A
Temperature :	25 °C	Relative Humidity :	51%
Pressure :	1010 hPa	Test Voltage :	DC 3.7V from battery
Test Mode :	Model 1	Polarization :	Horizontal

Frequency (MHz)	Meter Reading (dBμV)	Factor (dB)	Emission Level (dBμV/m)	Limits (dBμV/m)	Margin (dB)	Detector Type
128.1130	19.90	10.98	30.88	43.50	-12.62	QP
142.8243	12.48	11.32	23.80	43.50	-19.70	QP
221.3921	22.00	11.01	33.01	46.00	-12.99	QP
239.1473	21.45	10.83	32.28	46.00	-13.72	QP
277.0935	16.07	11.92	27.99	46.00	-18.01	QP
663.4728	6.98	20.90	27.88	46.00	-18.12	QP

Remark:

Factor = Antenna Factor + Cable Loss – Pre-amplifier.

Factor Including Cable loss and antenna coefficient

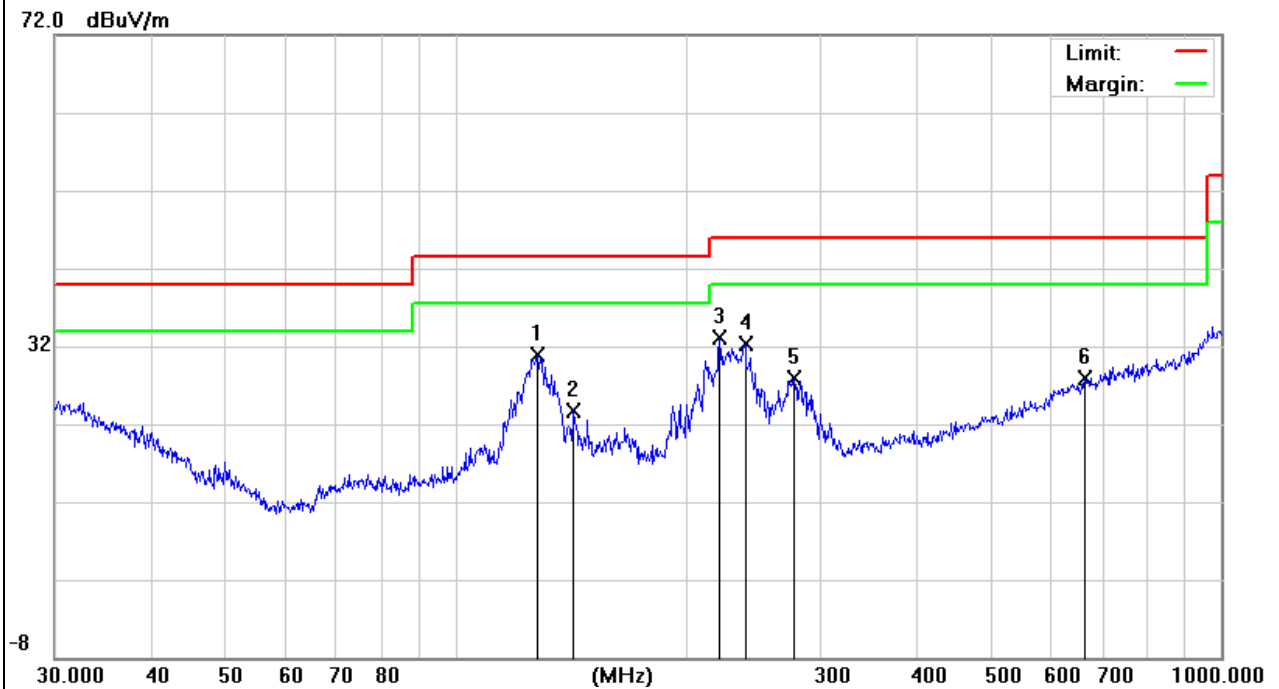

3.4.6 TEST RESULTS (ABOVE 1000 MHZ)

EUT :	VisDial X	Model Name :	ETL-815A
Temperature :	25 °C	Relative Humidity :	51%
Pressure :	1010 hPa	Test Voltage :	DC 3.7V from battery
Test Mode :	Model 1	Polarization :	Horizontal

Frequency (MHz)	Meter Reading (dBμV)	Factor (dB)	Emission Level (dBμV/m)	Limits (dBμV/m)	Margin (dB)	Detector Type
2406.000	91.23	-4.57	86.66	114.00	-27.34	peak
2406.000	76.59	-4.57	72.02	94.00	-21.98	AVG
4825.000	44.90	6.20	51.10	74.00	-22.90	peak
4825.000	35.82	6.20	42.02	54.00	-11.98	AVG
13282.500	-9.25	60.85	51.60	74.00	-22.40	peak
13282.500	-22.74	60.85	38.11	54.00	-15.89	AVG

Remark:
Factor = Antenna Factor + Cable Loss – Pre-amplifier.
No emission above 18GHz.

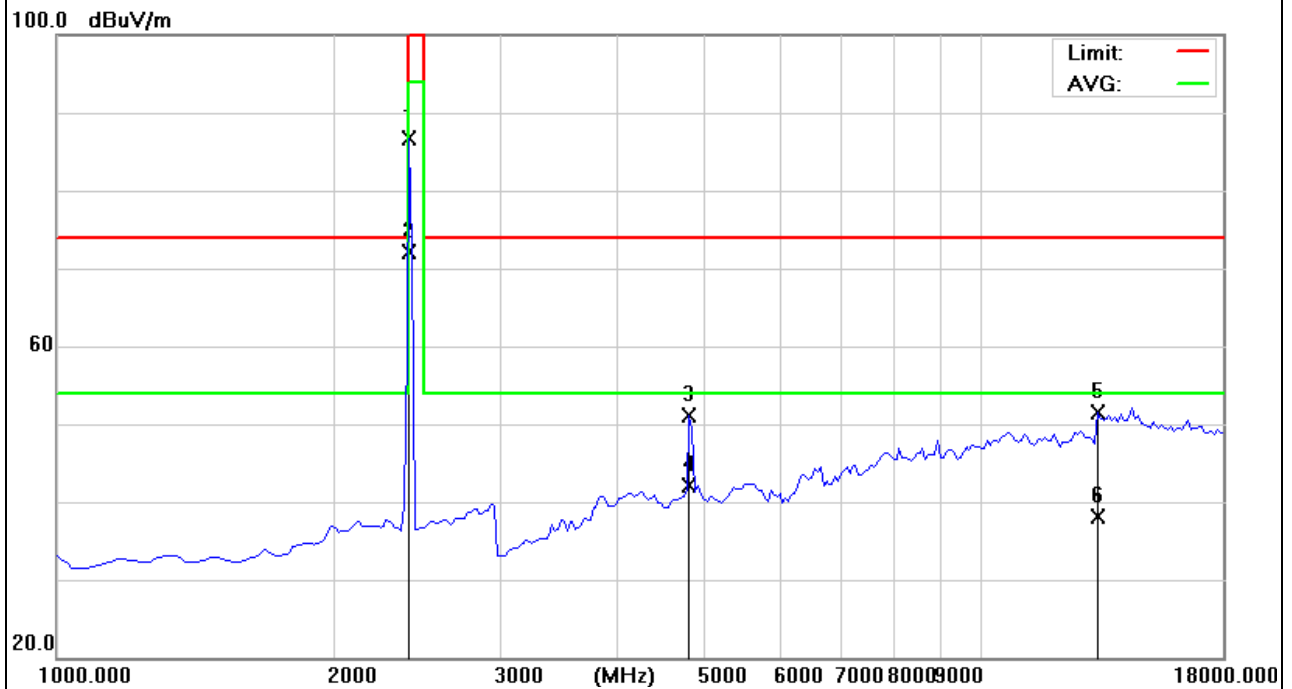

EUT :	VisDial X	Model Name :	ETL-815A
Temperature :	25 °C	Relative Humidity :	51%
Pressure :	1010 hPa	Test Voltage :	DC 3.7V from battery
Test Mode :	Model 1	Polarization :	Vertical

Frequency (MHz)	Meter Reading (dBμV)	Factor (dB)	Emission Level (dBμV/m)	Limits (dBμV/m)	Margin (dB)	Detector Type
2406.000	80.26	-4.57	75.69	114.00	-38.31	peak
2406.000	64.92	-4.57	60.35	94.00	-33.65	AVG
10605.000	-7.09	56.65	49.56	74.00	-24.44	peak
10605.000	-17.32	56.65	39.33	54.00	-14.67	AVG
13240.000	-9.37	60.82	51.45	74.00	-22.55	peak
13240.000	-20.81	60.82	40.01	54.00	-13.99	AVG

Remark:
 Factor = Antenna Factor + Cable Loss – Pre-amplifier.
 No emission above 18GHz.

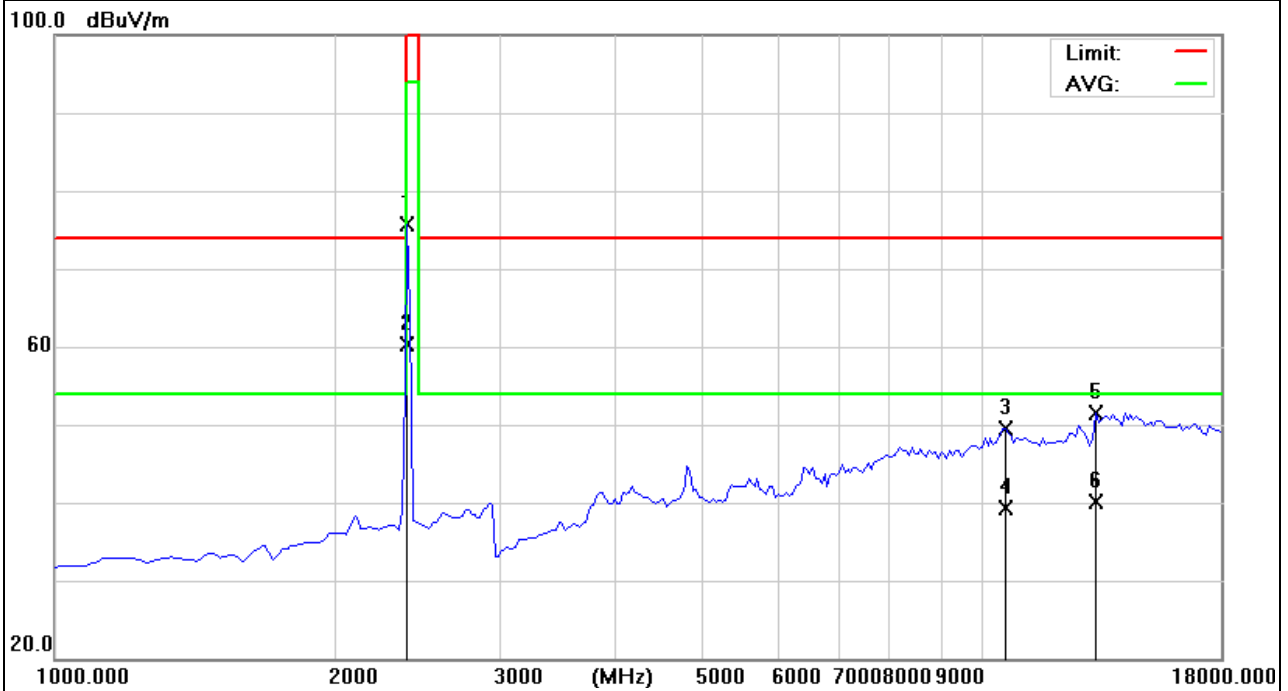

EUT :	VisDial X	Model Name :	ETL-815A
Temperature :	25 °C	Relative Humidity :	51%
Pressure :	1010 hPa	Test Voltage :	DC 3.7V from battery
Test Mode :	Model 2	Polarization :	Horizontal

Frequency (MHz)	Meter Reading (dBμV)	Factor (dB)	Emission Level (dBμV/m)	Limits (dBμV/m)	Margin (dB)	Detector Type
2439.000	90.69	-4.44	86.25	114.0 0	-27.75	peak
2439.000	73.77	-4.44	69.33	94.00	-24.67	AVG
4867.500	42.74	5.96	48.70	74.00	-25.30	peak
4867.500	32.19	5.96	38.15	54.00	-15.85	AVG
9712.500	-5.53	54.57	49.04	74.00	-24.96	peak
9712.500	-19.13	54.57	35.44	54.00	-18.56	AVG

Remark:
 Factor = Antenna Factor + Cable Loss – Pre-amplifier.
 No emission above 18GHz.

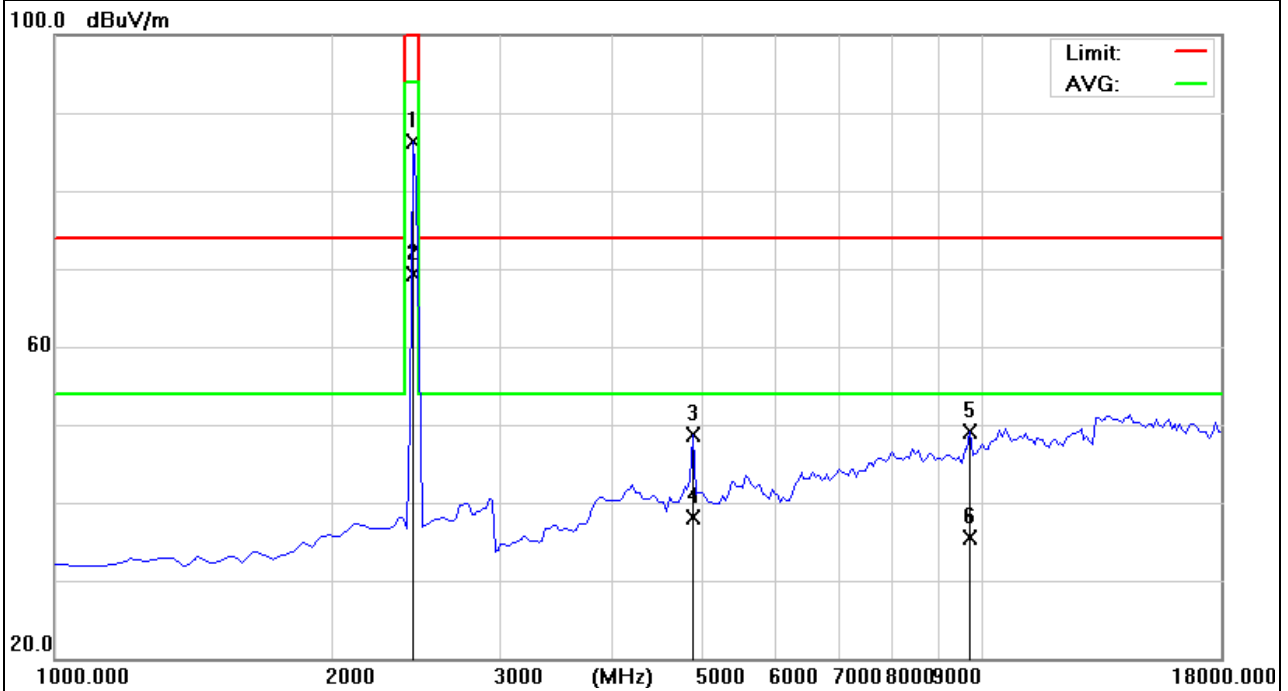

EUT :	VisDial X	Model Name :	ETL-815A
Temperature :	25 °C	Relative Humidity :	51%
Pressure :	1010 hPa	Test Voltage :	DC 3.7V from battery
Test Mode :	Model 2	Polarization :	Vertical

Frequency (MHz)	Meter Reading (dBμV)	Factor (dB)	Emission Level (dBμV/m)	Limits (dBμV/m)	Margin (dB)	Detector Type
2439.000	79.70	-4.44	75.26	114.00	-38.74	peak
2439.000	68.02	-4.44	63.58	94.00	-30.42	AVG
4867.500	38.59	5.96	44.55	74.00	-29.45	peak
4867.500	28.29	5.96	34.25	54.00	-19.75	AVG
13622.500	-8.97	60.69	51.72	74.00	-22.28	peak
13622.500	-22.04	60.69	38.65	54.00	-15.35	AVG

Remark:
Factor = Antenna Factor + Cable Loss – Pre-amplifier.
No emission above 18GHz.

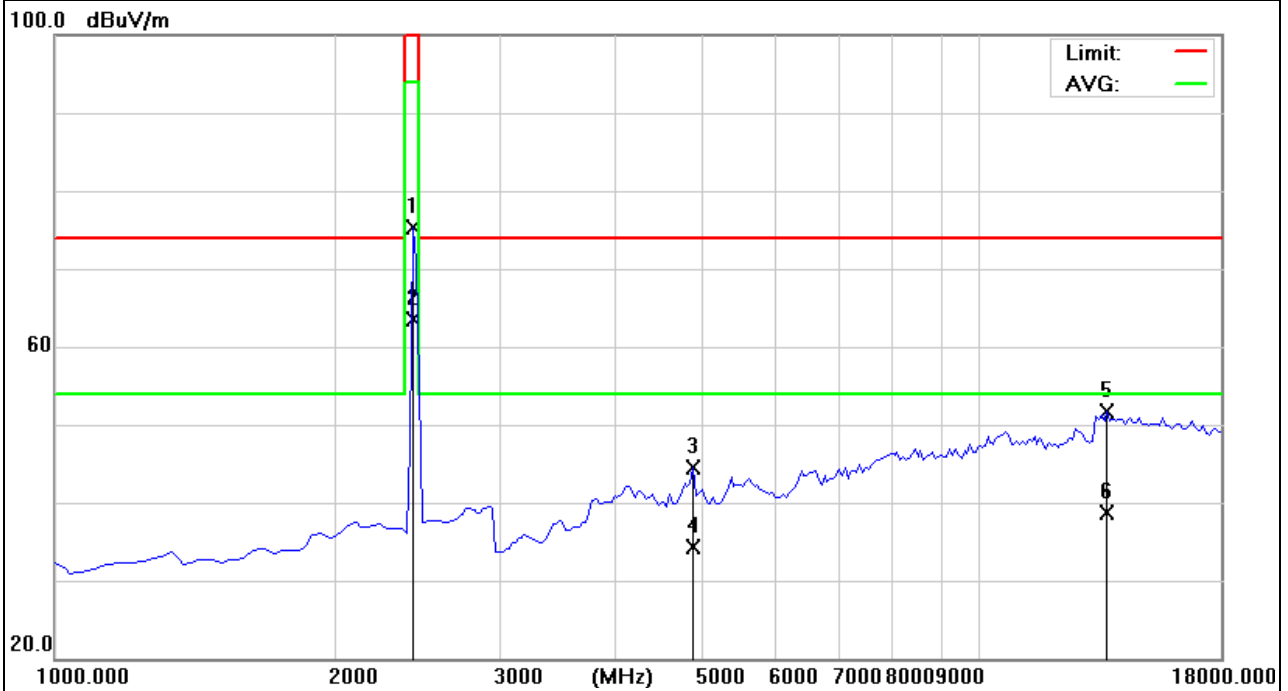

EUT :	VisDial X	Model Name :	ETL-815A
Temperature :	20 °C	Relative Humidity :	48%
Pressure :	1010 hPa	Test Voltage :	DC 3.7V from battery
Test Mode :	Model 3	Polarization :	Horizontal

Frequency (MHz)	Meter Reading (dBμV)	Factor (dB)	Emission Level (dBμV/m)	Limits (dBμV/m)	Margin (dB)	Detector Type
2475.000	88.96	-4.30	84.66	114.00	-29.34	peak
2475.000	74.65	-4.30	70.35	94.00	-23.65	AVG
4952.500	42.81	5.49	48.30	74.00	-25.70	peak
4952.500	34.53	5.49	40.02	54.00	-13.98	AVG
13240.000	-9.77	60.82	51.05	74.00	-22.95	peak
13240.000	-22.08	60.82	38.74	54.00	-15.26	AVG

Remark:
Factor = Antenna Factor + Cable Loss – Pre-amplifier.
No emission above 18GHz.

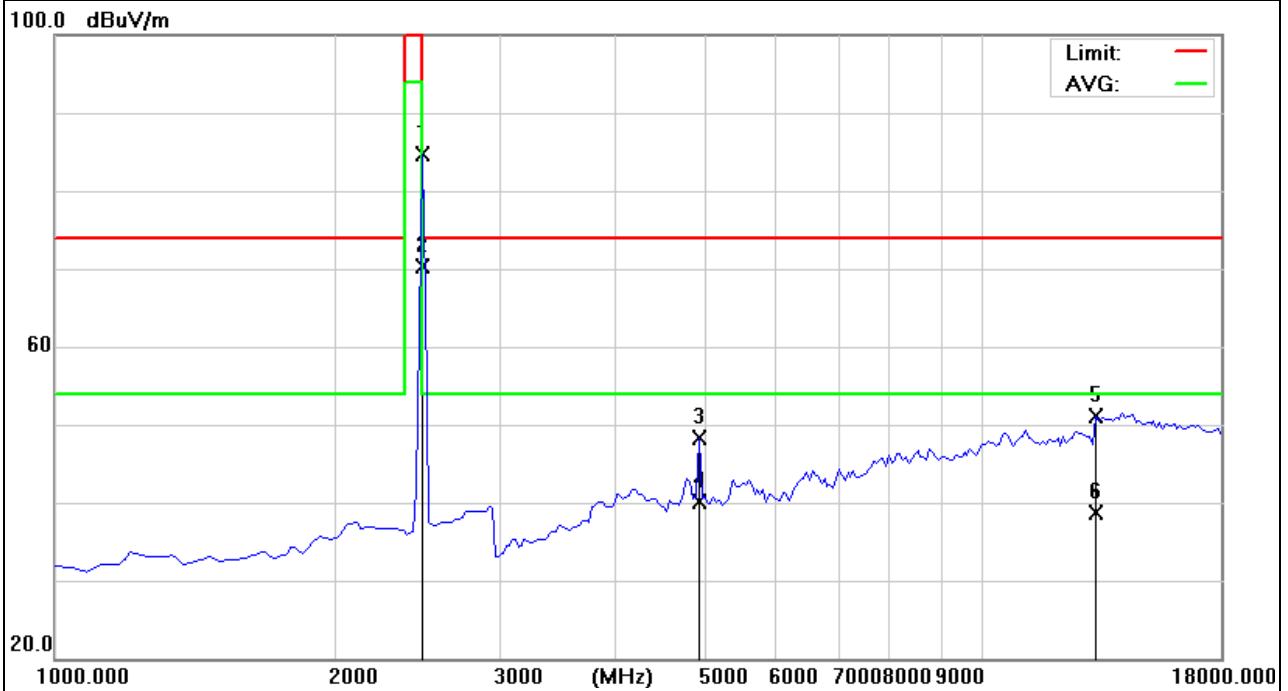

EUT :	VisDial X	Model Name :	ETL-815A
Temperature :	25 °C	Relative Humidity :	51%
Pressure :	1010 hPa	Test Voltage :	DC 3.7V from battery
Test Mode :	Model 3	Polarization :	Vertical

Frequency (MHz)	Meter Reading (dBμV)	Factor (dB)	Emission Level (dBμV/m)	Limits (dBμV/m)	Margin (dB)	Detector Type
2475.000	79.72	-4.30	75.42	114.00	-38.58	peak
2475.000	64.55	-4.30	60.25	94.00	-33.75	AVG
4952.500	39.60	5.49	45.09	74.00	-28.91	peak
4952.500	29.06	5.49	34.55	54.00	-19.45	AVG
13240.000	-9.06	60.82	51.76	74.00	-22.24	peak
13240.000	-21.41	60.82	39.41	54.00	-14.59	AVG

Remark:
Factor = Antenna Factor + Cable Loss – Pre-amplifier.
No emission above 18GHz.

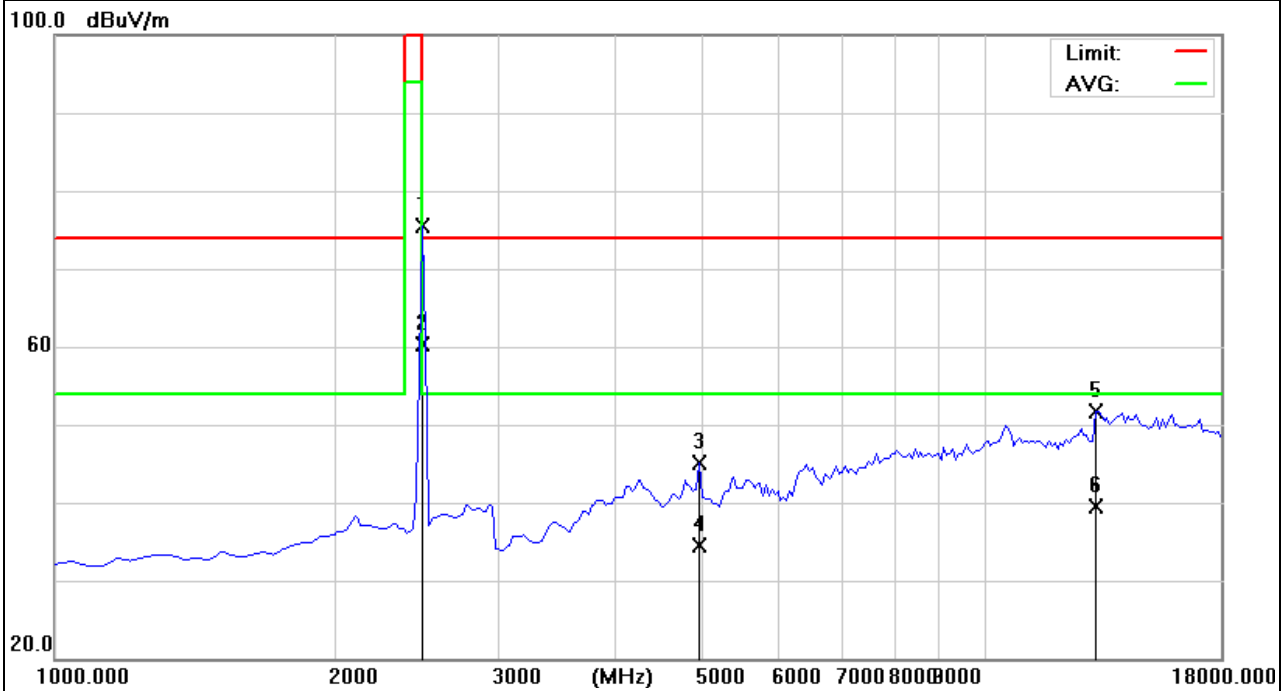

Note: EUT Pre-scan X/Y/Z orientation, only worst case is presented in the report(X orientation).

3.4.7 TEST RESULTS (RESTRICTED BANDS REQUIREMENTS)

EUT :	VisDial X	Model Name :	ETL-815A
Temperature :	25 °C	Relative Humidity :	51%
Pressure :	1010 hPa	Test Voltage :	DC 3.7V from battery
Test Mode :	TX-2475MHz	Polarization :	Horizontal

Frequency (MHz)	Meter Reading (dBμV)	Factor (dB)	Emission Level (dBμV/m)	Limits (dBμV/m)	Margin (dB)	Detector Type
2475.000	88.89	-4.30	84.59	114.00	-29.41	peak
2475.000	77.55	-4.30	73.25	94.00	-20.75	AVG
2483.500	39.99	-4.27	35.72	74.00	-38.28	peak
2483.500	29.39	-4.27	25.12	54.00	-28.88	AVG
2489.000	40.40	-4.25	36.15	74.00	-37.85	peak
2489.000	30.49	-4.25	26.24	54.00	-27.76	AVG

Remark:
Factor = Antenna Factor + Cable Loss – Pre-amplifier.

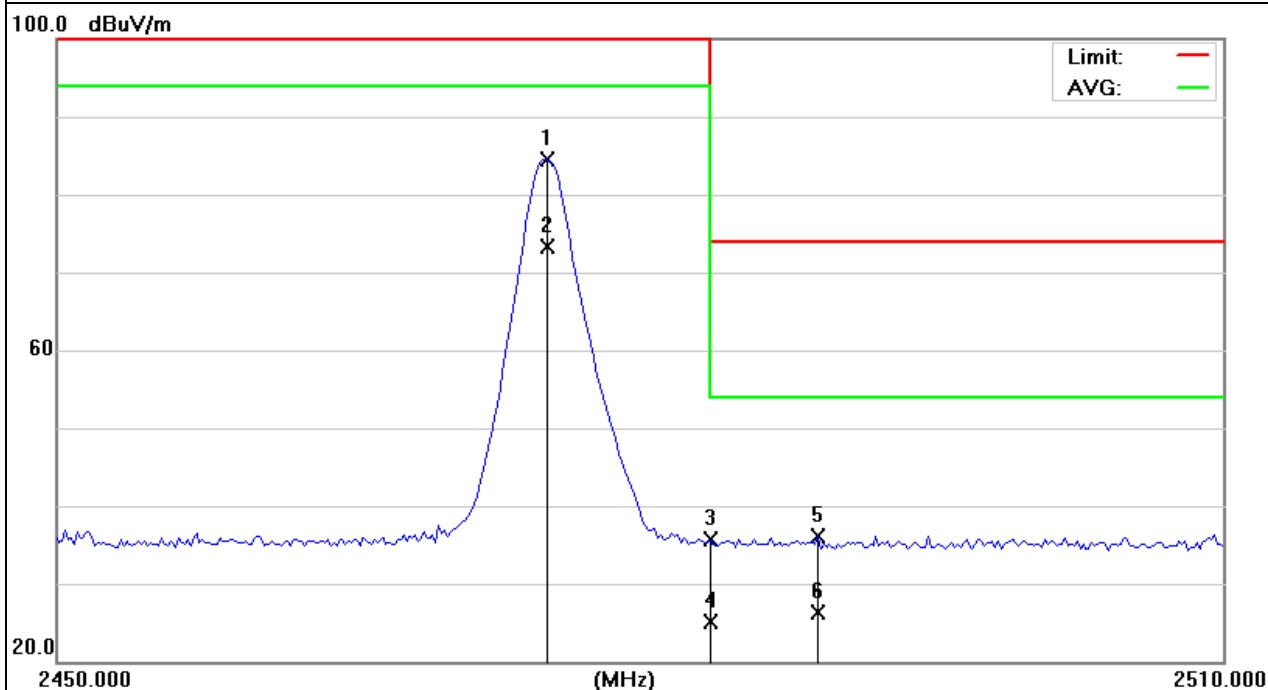

EUT :	VisDial X	Model Name :	ETL-815A
Temperature :	25 °C	Relative Humidity :	51%
Pressure :	1010 hPa	Test Voltage :	DC 3.7V from battery
Test Mode :	TX-2475MHz	Polarization :	Vertical

Frequency (MHz)	Meter Reading (dBμV)	Factor (dB)	Emission Level (dBμV/m)	Limits (dBμV/m)	Margin (dB)	Detector Type
2475.000	79.35	-4.30	75.05	114.00	-38.95	peak
2475.000	67.32	-4.30	63.02	94.00	-30.98	AVG
2483.500	40.00	-4.27	35.73	74.00	-38.27	peak
2483.500	29.38	-4.27	25.11	54.00	-28.89	AVG
2486.750	43.19	-4.26	38.93	74.00	-35.07	peak
2486.750	32.61	-4.26	28.35	54.00	-25.65	AVG

Remark:
Factor = Antenna Factor + Cable Loss – Pre-amplifier.

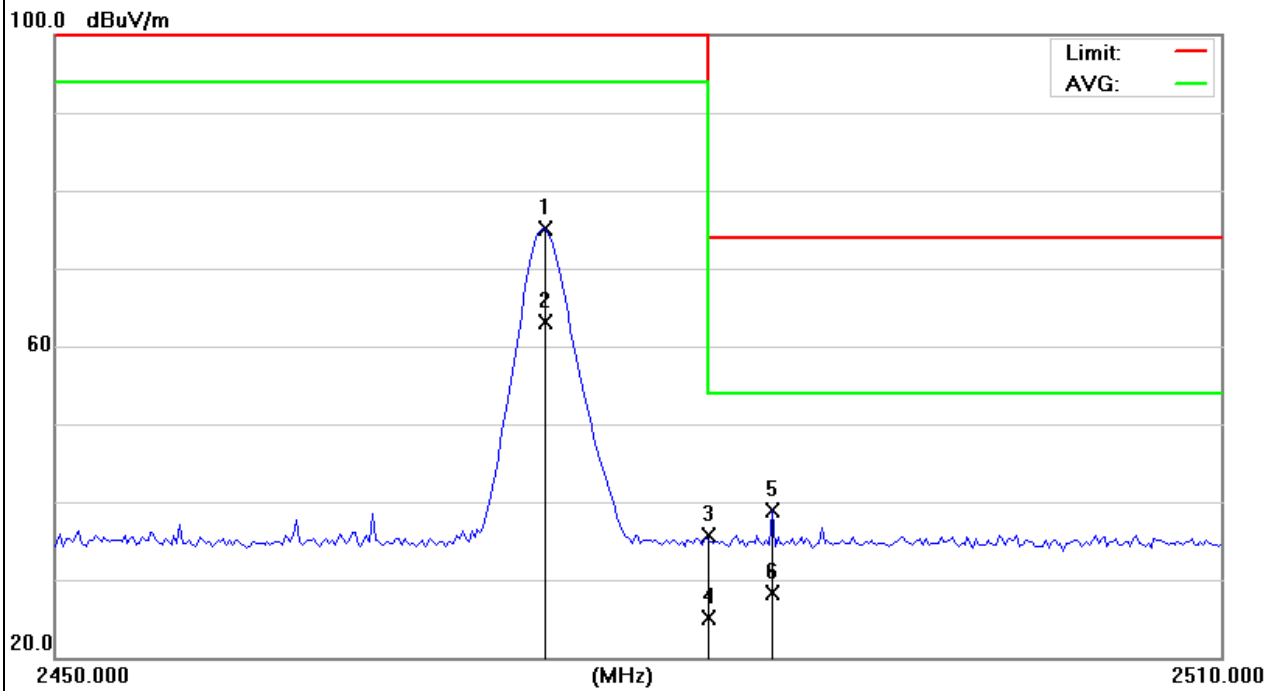

EUT :	VisDial X	Model Name :	ETL-815A
Temperature :	25 °C	Relative Humidity :	51%
Pressure :	1010 hPa	Test Voltage :	DC 3.7V from battery
Test Mode :	TX-2406MHz	Polarization :	Horizontal

Frequency (MHz)	Meter Reading (dBμV)	Factor (dB)	Emission Level (dBμV/m)	Limits (dBμV/m)	Margin (dB)	Detector Type
2357.025	40.91	-4.48	36.43	74.00	-37.57	peak
2357.025	32.50	-4.48	28.02	54.00	-25.98	AVG
2390.000	39.81	-4.57	35.24	74.00	-38.76	peak
2390.000	31.69	-4.57	27.12	54.00	-26.88	AVG
2400.000	39.99	-4.59	35.40	74.00	-38.60	peak
2400.000	30.61	-4.59	26.02	54.00	-27.98	AVG
2406.000	90.94	-4.57	86.37	114.00	-27.63	peak
2406.000	74.82	-4.57	70.25	94.00	-23.75	AVG

Remark:
Factor = Antenna Factor + Cable Loss – Pre-amplifier.

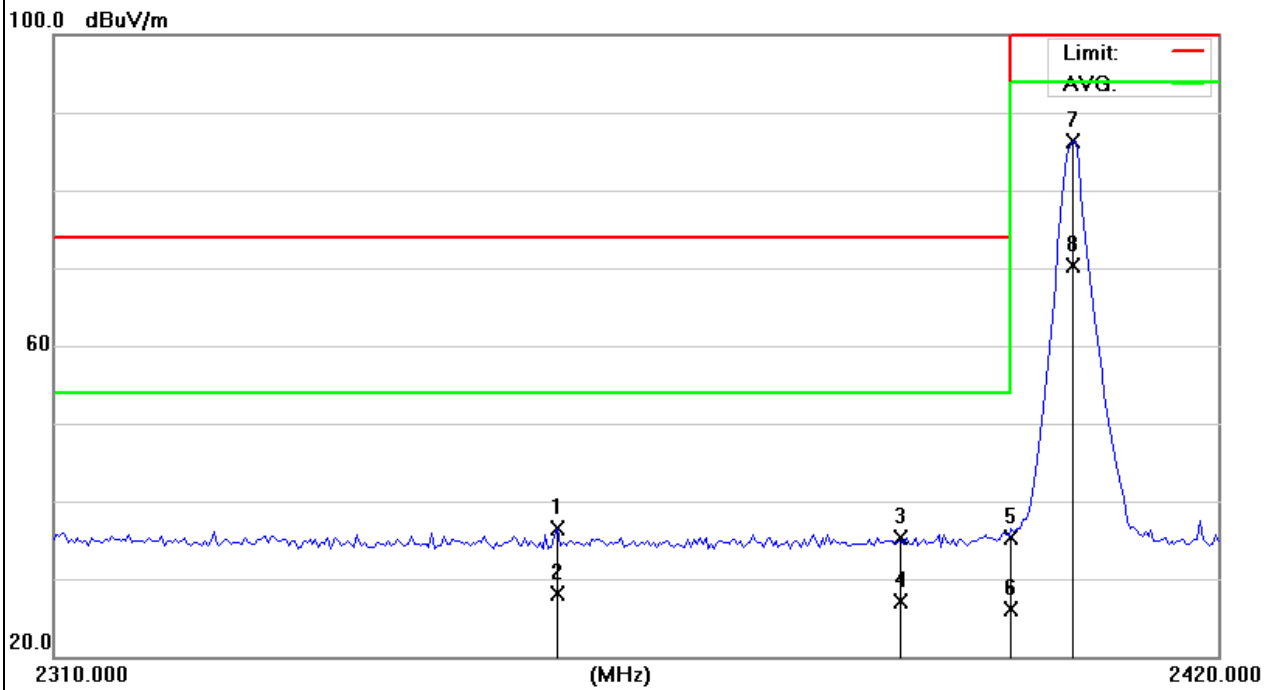

EUT :	VisDial X	Model Name :	ETL-815A
Temperature :	25 °C	Relative Humidity :	51%
Pressure :	1010 hPa	Test Voltage :	DC 3.7V from battery
Test Mode :	TX-2406MHz	Polarization :	Vertical

Frequency (MHz)	Meter Reading (dBμV)	Factor (dB)	Emission Level (dBμV/m)	Limits (dBμV/m)	Margin (dB)	Detector Type
2379.575	40.99	-4.54	36.45	74.00	-37.55	peak
2379.575	33.66	-4.54	29.12	54.00	-24.88	AVG
2390.000	40.49	-4.57	35.92	74.00	-38.08	peak
2390.000	29.90	-4.57	25.33	54.00	-28.67	AVG
2400.000	39.62	-4.59	35.03	74.00	-38.97	peak
2400.000	29.91	-4.59	25.32	54.00	-28.68	AVG
2406.000	80.66	-4.57	76.09	114.00	-37.91	peak
2406.000	69.90	-4.57	65.33	94.00	-28.67	AVG

Remark:
Factor = Antenna Factor + Cable Loss – Pre-amplifier.

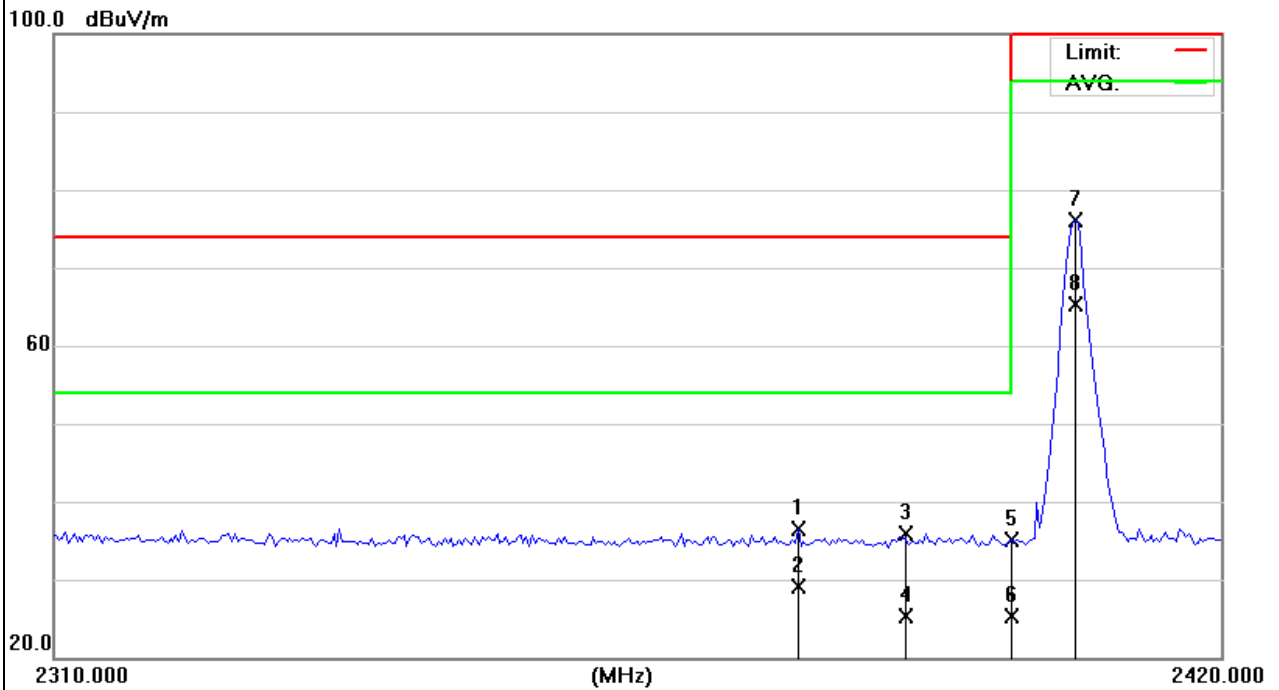

4. FREQUENCY TOLERANCE

4.1 FREQUENCY TOLERANCE LIMITS

The frequency tolerance of the carrier signal shall be maintained within $\pm 0.001\%$ of the operating frequency over a temperature variation of -20 degrees to $+50$ degrees C at normal supply voltage, and for a variation in the primary supply voltage from 85% to 115% of the rated supply voltage at a temperature of 20 degrees C.

4.2 TEST PROCEDURE

- a. The EUT was directly connected to the spectrum analyzer and antenna output port as show in the block diagram below,
- b. Spectrum Setting : RBW= 10KHz, VBW \geq RBW, Sweep time = Auto.

4.3 TEST SETUP



4.4 TEST RESULTS

EUT :	VisDial X	Model Name :	ETL-815A
Temperature :	26 °C	Relative Humidity :	53%
Pressure :	1020 hPa	Test Power :	DC 3.7V from battery
Test Mode :	Model 1/2/3		

2406MHz

Voltage (V)	Frequency(MHz)	Reading(MHz)	Frequency Tolerance	LIMIT
3.145	2406	2406.003	0.000125%	$\pm 0.001\%$
3.7	2406	2406.001	0.000042%	$\pm 0.001\%$
4.255	2406	2406.004	0.000166%	$\pm 0.001\%$

Temperature (°C)	Frequency(MHz)	Reading(MHz)	Frequency Tolerance	LIMIT
-20	2406	2406.004	0.000166%	$\pm 0.001\%$
-10	2406	2406.006	0.000249%	$\pm 0.001\%$
0	2406	2406.002	0.000083%	$\pm 0.001\%$
10	2406	2406.004	0.000166%	$\pm 0.001\%$
20	2406	2406.003	0.000125%	$\pm 0.001\%$
30	2406	2406.006	0.000249%	$\pm 0.001\%$
40	2406	2406.008	0.000333%	$\pm 0.001\%$
50	2406	2406.003	0.000125%	$\pm 0.001\%$

2439MHz

Voltage (V)	Frequency(MHz)	Reading(MHz)	Frequency Tolerance	LIMIT
3.145	2439	2439.006	0.000246%	±0.001%
3.7	2439	2439.003	0.000123%	±0.001%
4.255	2439	2439.002	0.000082%	±0.001%

Temperature (°C)	Frequency(MHz)	Reading(MHz)	Frequency Tolerance	LIMIT
-20	2439	2439.002	0.000082%	±0.001%
-10	2439	2439.001	0.000041%	±0.001%
0	2439	2439.003	0.000123%	±0.001%
10	2439	2439.005	0.000205%	±0.001%
20	2439	2439.004	0.000164%	±0.001%
30	2439	2439.002	0.000082%	±0.001%
40	2439	2439.006	0.000246%	±0.001%
50	2439	2439.003	0.000123%	±0.001%

2475MHz

Voltage (V)	Frequency(MHz)	Reading(MHz)	Frequency Tolerance	LIMIT
3.145	2475	2475.006	0.000242%	±0.001%
3.7	2475	2475.004	0.000162%	±0.001%
4.255	2475	2475.002	0.000081%	±0.001%

Temperature (°C)	Frequency(MHz)	Reading(MHz)	Frequency Tolerance	LIMIT
-20	2475	2475.002	0.000081%	±0.001%
-10	2475	2475.007	0.000283%	±0.001%
0	2475	2475.004	0.000162%	±0.001%
10	2475	2475.009	0.000364%	±0.001%
20	2475	2475.003	0.000121%	±0.001%
30	2475	2475.005	0.000202%	±0.001%
40	2475	2475.004	0.000162%	±0.001%
50	2475	2475.005	0.000202%	±0.001%

5. BANDWIDTH TEST

5.1 TEST PROCEDURE

- a. The EUT was directly connected to the spectrum analyzer and antenna output port as show in the block diagram below,
- b. Spectrum Setting : RBW= 100KHz, VBW \geq RBW, Sweep time = Auto.

5.1 DEVIATION FROM STANDARD

No deviation.

5.1 TEST SETUP

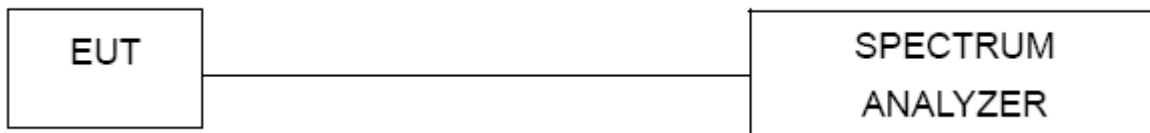

6. TEST RESULTS

EUT :	VisDial X	Model Name :	ETL-815A
Temperature :	26 °C	Relative Humidity :	53%
Pressure :	1020 hPa	Test Power :	DC 3.7V from battery
Test Mode :	Model 1/2/3		

Test Channel	Frequency (MHz)	20 dBc Bandwidth (MHz)
CH01	2406	0.291
CH34	2439	0.304
CH70	2475	0.308

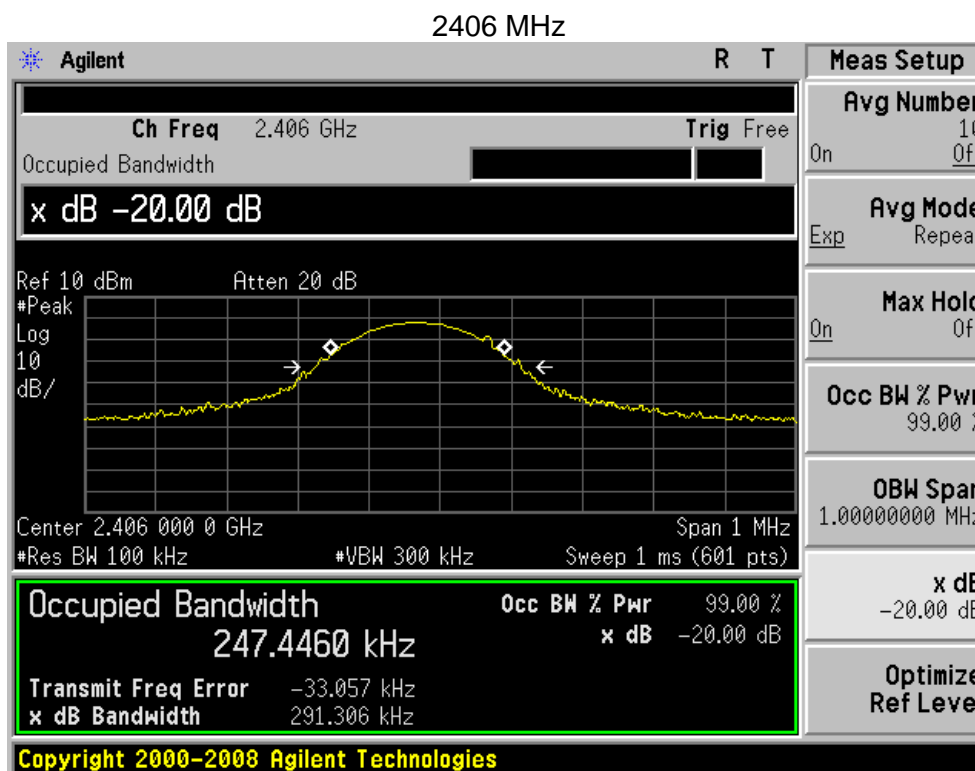

2439 MHz

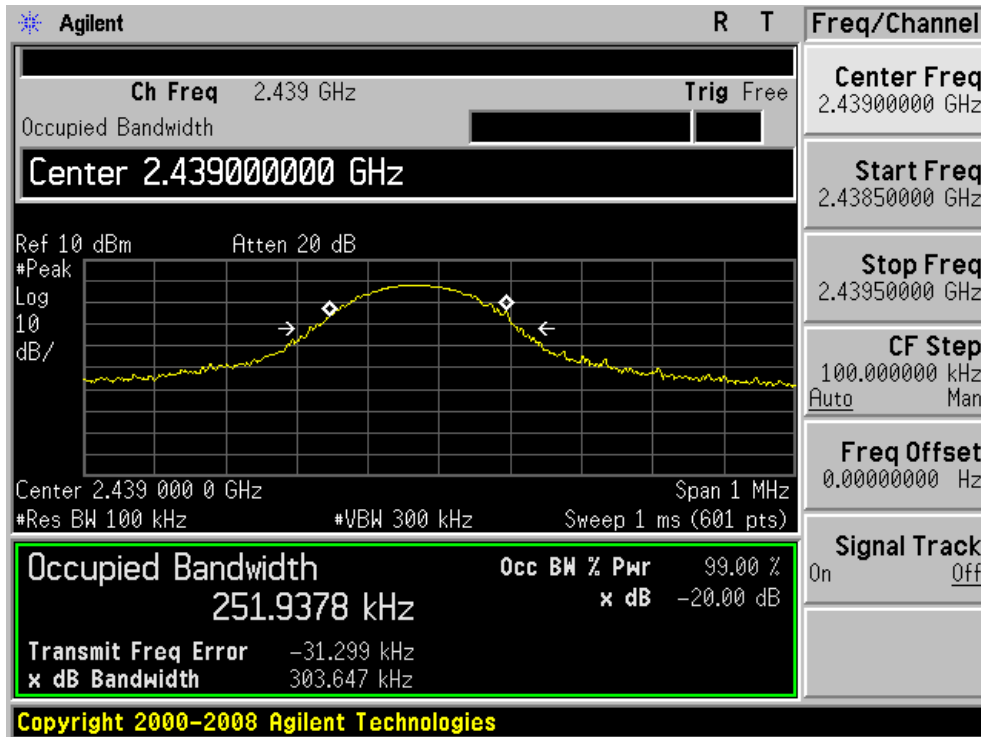

2475 MHz

