



TELEMATICS
MOBILE INFORMATION EXCHANGE

**MiX LTE External Modem
for FM 3xxx installs
Quick Start Guide**



Table of Contents

1	Introduction.....	3
2	Process Overview	3
3	Applicable Supporting Documents	4
4	Environmental Requirements	4
5	Installer Requirements	4
6	Regulatory Compliance	4
7	Pre Install Requirements	4
7.1	Firmware upgrade	4
7.2	Config update	4
7.3	Confirm existing SIM details	5
7.4	Ensure modem has an Activated LTE SIM.....	5
8	Installing hardware	6
8.1	Hardware and Kit Part Numbers.....	7
8.2	Mounting Considerations.....	7
9	Installation procedure	8
10	Testing procedure.....	9
11	Post install administration	10
12	Appendix A – Diagnostics Plugs Required	11
12.1	Creating a Power down plug	11
12.2	Creating a Communication diagnostics plug	11

1 Introduction

There is a need to extend the working life of FM 3xxx 2G/3G on board computer (OBC) hardware in regions where an evolution in cellular technology is taking place. By the addition of an external modem supporting the latest LTE CAT M1 technology and an over the air firmware upgrade, the OBC can transition from using its internal modem to using a new technology external modem. This simple addition to the install avoids replacing the OBC and all its peripherals, reducing swap out time, saving cost and extending the life of all the hardware in the vehicle.

This document describes the installation requirements of the MiX LTE External modem being fitted to an FM 3xxx OBC.

2 Process Overview

For a successful transition from internal to external modem the OBC needs to be configured correctly and loaded with updated firmware supporting the new external modem device.

The external modem hardware is designed to attach to a free serial port on the OBC. When installing on an FM 3xxx device it will use the S3 port but leave S1 free for use by other peripheral devices. This means for example, that it will be unsuitable for adding to an install with an Iridium modem already on S2. It could however be fitted to any install that has a Rovi on S1.

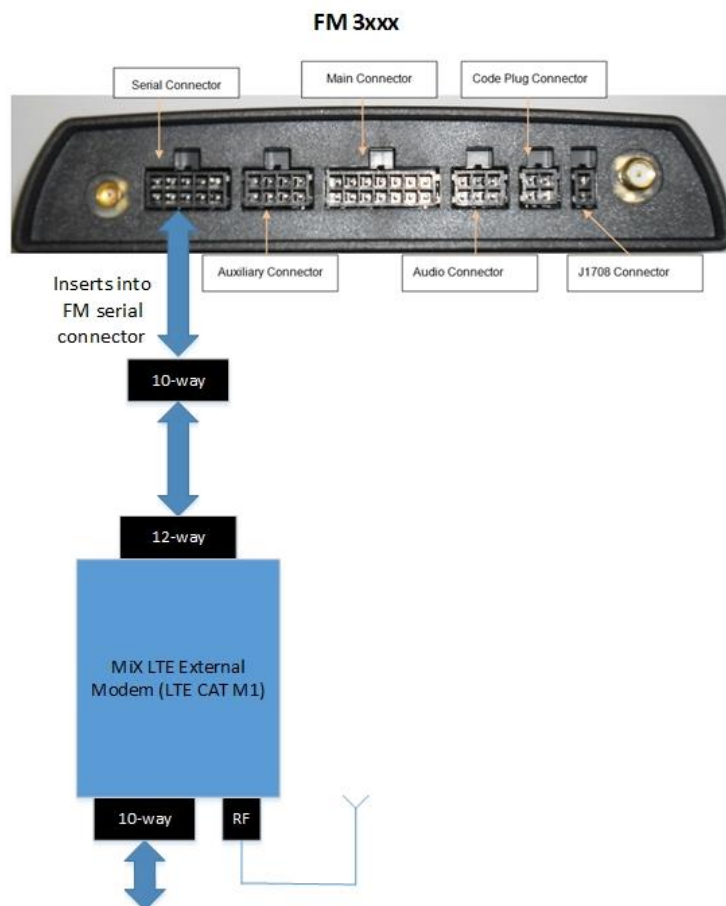

Figure 1 Block Diagram of FM plus LTE CAT M1 External Modem

During the install the OBC will detect the LTE modem. Once it has confirmed that it can communicate using this modem it will permanently transition over to using this modem and no longer make use of the internal one. The firmware is not configured to fall back and attempt communication over the internal modem again if the LTE coverage is poor.

3 Applicable Supporting Documents

[1] PFS LTE External Modem - V1

4 Environmental Requirements

Do not immerse the unit in water as the housing is not waterproof. The unit can however withstand some exposure to water drops.

5 Installer Requirements

The system should only be installed by a suitably qualified vehicle technician with a basic knowledge of the operation of telematics equipment and the Rovi Display Unit.

6 Regulatory Compliance

This device complies with Part 15 of the FCC Rules. Operation is subject to the following two conditions: (1) this device may not cause harmful interference, and (2) this device must accept any interference received, including interference that may cause undesired operation.

No changes / modifications shall be made to the equipment without the manufacturer's permission as this may void the user's authority to operate the equipment.

This equipment complies with FCC radiation exposure limits for an uncontrolled environment. This equipment shall be installed and operated with a minimum distance of 20 cm (7.9 in) between users and/or bystanders and the device.

7 Pre Install Requirements

Before scheduling the install on any asset the steps below should be completed.

7.1 Firmware upgrade

Prior to scheduling any visit to the vehicle the FM firmware on the OBC needs to be updated to E18.09.06.18 – BAS 1.71C or higher. This needs to be done as an over the air upload. It is important to have confirmed the OBC is running this firmware before fitting the external modem hardware.

Note: Once this firmware is loaded onto an operational OBC the firmware continues to use the internal modem until it detects an external modem connected. So the firmware can be upgraded at any time before the install of the LTE modem takes place with no impact on normal operation.

7.2 Config update

The assets config must be updated to reflect that an external modem has or will be attached to serial line S3.

Before that can be done the device needs to be made available in the peripheral library.

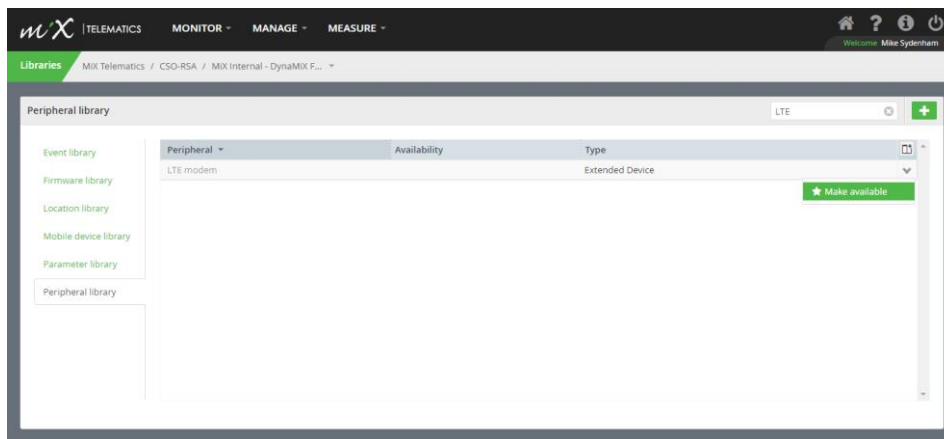

Then edit the Mobile device template, locate the S3 line and set it for the LTE Modem.

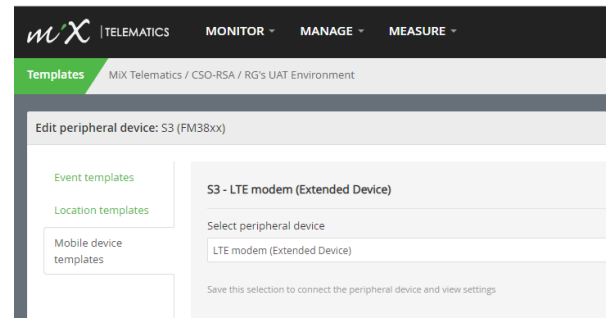
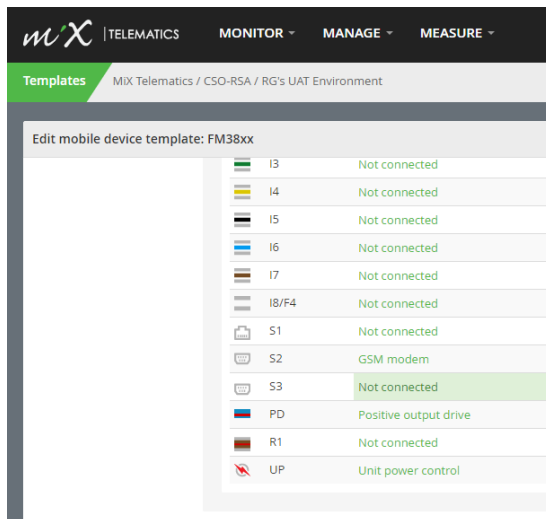

Note: As this is only suitable for installs that currently have S3 free, this change can be done to the config any time before the install of the LTE modem takes place with no impact on normal operation.

7.3 Confirm existing SIM details

If the 2G/3G SIM details for the asset are not already recorded it is important to capture these details prior to the install. This will ensure that the contract on the original SIM can be terminated once the transition to the LTE modem is successful

Note: The FM 3xxx will report SIM information like the IMSI number which is typically used to link the asset to a contract with the cellular provider. Once the new LTE modem is installed and operational the details of the SIM in the LTE modem are reported and the details of the original SIM will no longer be sent by the OBC.

7.4 Ensure modem has an Activated LTE SIM

The LTE External modem requires its own LTE capable SIM. In some cases a deactivated SIM will already be inserted in the modem at time of manufacturer e.g. An AT&T SIM is fitted to all stock for MiX NA. The details of the SIM are included on the modem's label as well as provided in a digital list with every purchase order. If the modem is supplied without a SIM, indicated by blank ICCID details on the label, then the SIM

cover on the modem housing needs to be removed and the SIM inserted in the orientation indicated on the cover. Activation of the SIM on the cellular provider’s portal must also be done before attempting an install. The SIM must also be configured not to require any PIN code or the modem will be unable to use it to connect to the network.

Note: If the install is attempted with a modem not containing an operational, unpinned LTE SIM the OBC will fail to transition from internal to external modem. The OBC will simply continue to use its internal SIM. This is a failsafe built in to ensure that communication with the asset is not lost. If there is any doubt in the SIM activation process then the Installation and Testing steps shown below can be performed by plugging the modem into a test FM 3xxx device and confirming operation before the Modem kit is supplied for the install.

8 Installing hardware

One MiX LTE CAT M1 Modem kit needs to be available for each asset that is to be upgraded to LTE. The solution is designed so that the LTE modem and its harness fit in-line with an existing serial harness that may already be plugged into the FM’s serial connector. See below. This means that this install is a simple ‘plug and play’ without the need for any cutting or splicing into the existing install wiring.

Note: As the S3 line is taken by the LTE modem this line is no longer available and not even passed through to the serial connector. S1 is however untouched and passed directly through the modem device so that the original serial peripheral can be reattached.

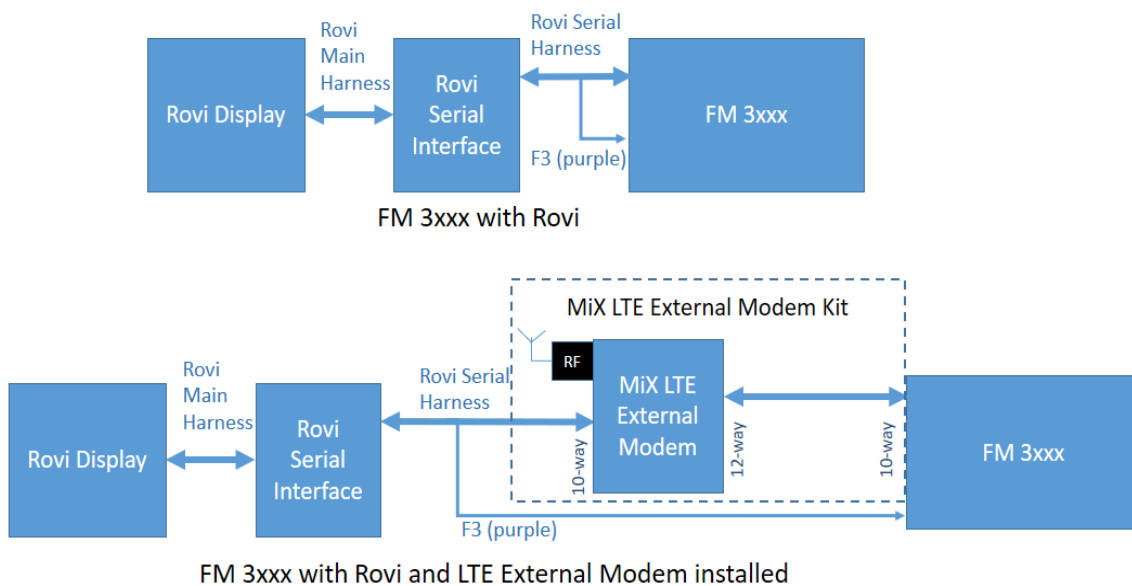

Figure 2 Overview of System before and after the external modem install

8.1 Hardware and Kit Part Numbers

Part Number	Name	Picture	Description
P0014MT	LTE Cat M1 External Modem Kit		LTE Cat M1 External Modem kit for installation on FM 3xxx
440FT0077	LTE Cat M1 External Modem		LTE Category M1 External Modem
A0011MT	Serial Harness SR4		FM LTE Ext. Serial Harness SR4
A0016MT	External LTE Antenna PA3		LTE Cat M1 Antenna for External Modem

8.2 Mounting Considerations

8.2.1 LTE Modem

Select a location close to where the FM 3xxx is installed to mount the LTE modem hardware. Secure the hardware to the vehicle using at least one zip/cable tie.

8.2.2 LTE External Antenna

Mount the external antenna on a non-metal surface to ensure optimal performance. Use the double sided tape provided or zip/cable ties to firmly secure the antenna.

Caution:

- a) Do not mount the LTE modem on top of the FM 3xxx unit
- b) Do not mount the External LTE Antenna on top of the FM GSM Antenna

9 Installation procedure

Step	Part Number	Picture	Description
1.	A0011MT And 440FT0077		<p>The 12-pin connector of the “FM LTE Ext. Serial Harness SR4” should already be connected to the 12-pin socket on the LTE Modem. If not connect these two item together.</p> <p>Note: it is also possible to plug the other end of the harness, the 10-pin connector, into the modem. This is incorrect and will not allow the install to proceed.</p>
2.	A0011MT		<p>If there is anything connected to the 10-pin serial connector on the FM 3xxx, disconnect it and connect it to the 10-pin side of the LTE modem.</p> <p>Then</p> <p>Connect the 10-pin side of the “FM LTE External Serial Harness SR4” to the 10 pin socket (serial port) on the FM.</p>
3.	A0016M		<p>Connect the External LTE blade antenna to the socket on the LTE modem</p> <p>Note: It has the same connector as the GPS antenna on the FM 3xxx. Leave the GPS antenna</p>

			connected to the FM. The antenna that comes with the kit must plug into the external modem
--	--	--	--

10 Testing procedure

Testing of the install will require the installer to have access to a Power down plug and a Communication/GSM Diagnostics plug for the FM 3xxx. These are the same tools used for standard FM diagnostics and they can be programmed using the Dealer Utility application. See Appendix A

Note: The FM needs the internal SIM and modem to be operational during this process. Make sure it is still operational and remains installed during the test.

Step	Action	Result
1.	The detection of an externally connected LTE modem will occur automatically over time. To force the process to kick-off immediately after the modem is connected, insert a Power down Plug into the code plug socket of the FM 3xxx to force the unit to restart and check for a modem.	The FM 3xxx device will reboot. As it starts up it will determine if an operational external modem is attached on S3.
2.	Insert the standard Communication/GSM Diagnostics Plug into the code plug socket of the FM.	The LED on the code plug socket will stay on while the plug is inserted and the unit is in LTE mode.
3.	Confirmation of LTE mode being actively used by the FM 3xxx is required. Confirm that LTE communications is active.	LTE Communication active - The buzzer will give 5 short widely spaced beeps when LTE mode is detected. (.) OR 3G/GPRS communication from internal modem – The buzzer will give 3 shortly widely spaced beeps when communicating using its internal modem. (. . .)
4.	Allow time for the device to transition from internal to external modem. It may take a few minutes for LTE communication to be established	The communication beeps will occur when the plug is first inserted or whenever communications changes from internal modem to external modem.

	and the LTE beep pattern to be heard	
5.	Confirm the SIM is able to facilitate an active connection to the network	When a link becomes active the buzzer will give 2 quick short beeps. (. .)
6.	Confirm normal operation of the LTE modem Modem is idle with no incoming data	When the OBC successfully queries the modem for data, but there is no incoming data, the buzzer will give 1 medium beeps. (-) This usually occurs around once a second (but could be longer for a very slow config).
7.	Confirm normal operation of the LTE modem Modem is receiving data	When data is received, the buzzer will give 2 medium beeps. (- -) This usually occurs once a second (but could be longer for a very slow config).
8.	Confirm normal operation of the LTE modem Modem is sending data	When an active message is sent, the unit will give 5 quick short beeps. (.)
9.	Confirm the modem is not continuously in an error state where it is unable to send or receive data	Occasionally the modem will report an error. This will be indicated by a long beep. (___) If this occurs continuously the modem is not working as it should and the install cannot be completed.

11 Post install administration

Once the install is confirmed the FM 3xxx OBC will use the external LTE modem for all its communication going forward. The firmware does not implement any fallback to 2G/3G by switching back to the internal modem if the OBC it is out of LTE coverage. There is therefore no point in keeping the original internal SIM active. The original SIM can be deactivated using the details captured for the asset prior to installing the LTE External modem.

12 Appendix A – Diagnostics Plugs Required

12.1 Creating a Power down plug

Using the Dealer Utility and a standard blue plug, open the format menu and select 'Power down plug'. Once formatted correctly this plug should be marked as a power down plug. It will be used after the LTE External modem has been attached to force the FM to check for the additional modem.

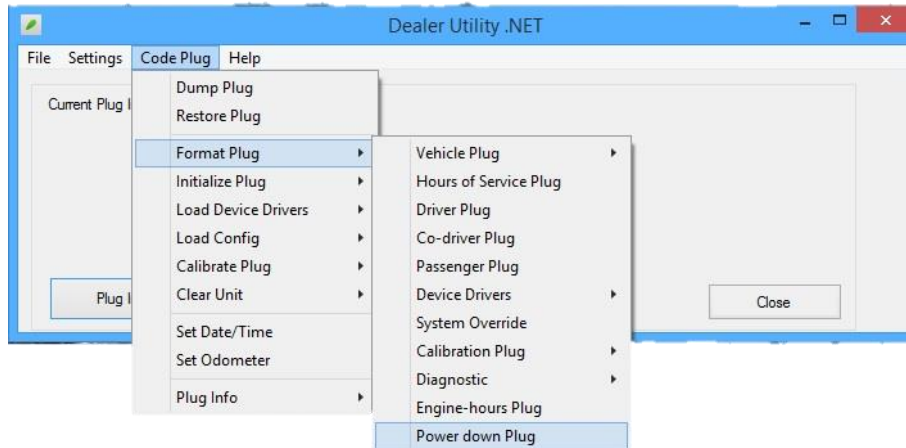

12.2 Creating a Communication diagnostics plug

Using the Dealer Utility and a standard blue plug, open the format menu and select Diagnostics -> DECT/GSM/SMS/GPRS. Once formatted it should be marked as a Communication Diagnostics plug, also often referred to as a GSM plug. It will be used when confirming that the external modem is communicating correctly.

