



TEST REPORT

IEC 62368-1

Audio/video, information and communication technology equipment Part 1: Safety requirements

Report Number : 071-75952029-010

Date of issue : 2023-02-23

Total number of pages : 51

Name of Testing Laboratory TÜV SÜD
preparing the Report Octagon House, Concorde Way, Segensworth North, Fareham,
 Hampshire, PO15 5RL, UNITED KINGDOM

Applicant's name MiX Telematics International (Pty) Ltd.
Address Blaauwklip Office Park 2, Cnr Strand Str and Webers Valley,
 Stellenbosch, 7600, South Africa

Test specification:

Standard IEC 62368-1:2014

Test procedure Private

Non-standard test method N/A

TRF template used IECEE OD-2020-F1:2021, Ed.1.4

Test Report Form No. IEC62368_1D

Test Report Form(s) Originator .. : UL(US)

Master TRF Dated 2022-04-14



Copyright © 2022 IEC System of Conformity Assessment Schemes for Electrotechnical Equipment and Components (IECEE System). All rights reserved.

This publication may be reproduced in whole or in part for non-commercial purposes as long as the IECEE is acknowledged as copyright owner and source of the material. IECEE takes no responsibility for and will not assume liability for damages resulting from the reader's interpretation of the reproduced material due to its placement and context.

This report is not valid as a CB Test Report unless signed by an approved CB Testing Laboratory and appended to a CB Test Certificate issued by an NCB in accordance with IECEE 02.

General disclaimer:

The test results presented in this report relate only to the object tested.
 This report shall not be reproduced, except in full, without the written approval of the Issuing CB Testing Laboratory. The authenticity of this Test Report and its contents can be verified by contacting the NCB, responsible for this Test Report.

Test Item description	Bluetooth Driver ID remote fob	
Trade Mark(s)		
Manufacturer	MiX Telematics International (Pty) Ltd. Blaauwklip Office Park 2, Cnr Strand Str and Webers Valley, Stellenbosch, 7600, South Africa	
Model/Type reference	BT DID, BT HOS DID	
Ratings	3V coin cell	
Responsible Testing Laboratory (as applicable), testing procedure and testing location(s):		
<input checked="" type="checkbox"/>	Testing Laboratory:	TÜV SÜD
Testing location/ address	Octagon House, Concorde Way, Segensworth North, Fareham, Hampshire, PO15 5RL, UNITED KINGDOM	
Tested by (name, function, signature)	Sam Waters Product Safety Specialist	
Approved by (name, function, signature)	Dennis Butcher Reviewing Engineer	

<p>List of Attachments (including a total number of pages in each attachment):</p> <p>Attachment 1: European Group Differences and National Differences (3 pages)</p> <p>Attachment 2: U.S.A. and Canada National Differences (6 pages)</p> <p>Attachment 3: Australia / New Zealand National Differences (12 pages)</p> <p>Attachment 4: Record Photographs (4 pages)</p>	
<p>Summary of testing:</p>	
<p>Tests performed (name of test and test clause):</p> <p>4.8 – Products containing lithium coin / button cell batteries</p> <p>5.2 – Classification of electrical energy sources</p> <p>6.2.2 – Power Source circuit classification</p> <p>6.4.8.3 – Constructional requirements for a fire enclosure</p> <p>8.2 – Mechanical energy source classifications</p> <p>B.2.6 – Normal operating condition temperature measurement</p> <p>B.3.6 – Reverse battery polarity</p> <p>B.4 – Simulated single fault conditions</p> <p>F.3.10 – Test for permanence of markings</p> <p>M.3 – Battery protection circuits</p> <p>P.2.2 – Safeguards against entry of a foreign object</p> <p>T.5 – Steady force test, 250N</p> <p>T.7 – Drop test</p> <p>T.8 – Stress relief test</p>	<p>Testing location:</p> <p>TÜV SÜD Octagon House Concorde Way Segensworth North Fareham Hampshire PO15 5RL UNITED KINGDOM</p>
<p>Summary of compliance with National Differences (List of countries addressed):</p> <p>See attachments</p> <p><input checked="" type="checkbox"/> The product fulfils the requirements of:</p> <p>IEC 62368-1:2014 EN 62368-1:2014 UL 62368-1:2014 CSA C22.2-No. 62368-1-14 AS/NZS 62368.1:2018</p>	

Use of uncertainty of measurement for decisions on conformity (decision rule) :

No decision rule is specified by the IEC standard, when comparing the measurement result with the applicable limit according to the specification in that standard. The decisions on conformity are made without applying the measurement uncertainty ("simple acceptance" decision rule, previously known as "accuracy method").

Other:

Determination of conformity with the specification limits is based on the decision rule according to IEC Guide 115:2021, Clause 4.4.2 (Procedure 1).

Upper Specification Limit (A lower limit or specification with an upper and a lower limit are treated the same).

- Compliance with the requirement: If a specification limit is not breached by a measurement result plus the expanded uncertainty with a 95% coverage probability, then compliance with the specification will be stated (e.g. Pass).
- Non-Compliance with the requirement: If a specification limit is exceeded by the measurement result minus the expanded uncertainty with a 95% coverage probability, then non-compliance with the specification will be stated (e.g. Fail).
- Inconclusive result: if a measurement result plus/minus the expanded uncertainty with a 95% coverage probability overlaps the limit it will be stated that it is not possible to state compliance or non-compliance.

Risk: The uncertainty of measurement about the measured result is negligible with regard to the final pass/fail decision. The measurement result can be directly compared with the test limit to determine conformance with the requirement (compare IEC Guide 115). The level of risk to falsely accept and falsely reject items is further described in ILAC-G8

Copy of marking plate:

The artwork below may be only a draft. The use of certification marks on a product must be authorized by the respective NCBs that own these marks.



BT HOS DID – Model identification

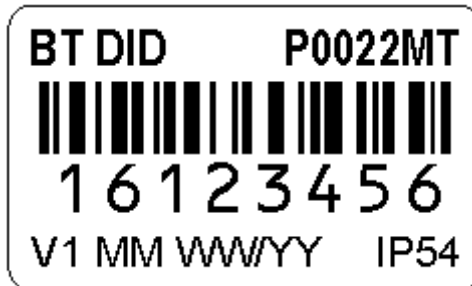

BT DID – Model identification



Manufacturer identification

TEST ITEM PARTICULARS:	
Classification of use by	<input checked="" type="checkbox"/> Ordinary person <input type="checkbox"/> Instructed person <input type="checkbox"/> Skilled person <input checked="" type="checkbox"/> Children likely to be present
Supply Connection	<input type="checkbox"/> AC Mains <input type="checkbox"/> DC Mains <input checked="" type="checkbox"/> External Circuit - not Mains connected - <input checked="" type="checkbox"/> ES1 <input type="checkbox"/> ES2 <input type="checkbox"/> ES3
Supply % Tolerance	<input type="checkbox"/> +10%/-10% <input type="checkbox"/> +20%/-15% <input type="checkbox"/> +____%/ -____% <input checked="" type="checkbox"/> None
Supply Connection – Type	<input type="checkbox"/> pluggable equipment type A - <input type="checkbox"/> non-detachable supply cord <input type="checkbox"/> appliance coupler <input type="checkbox"/> direct plug-in <input type="checkbox"/> mating connector <input type="checkbox"/> pluggable equipment type B - <input type="checkbox"/> non-detachable supply cord <input type="checkbox"/> appliance coupler <input type="checkbox"/> permanent connection <input checked="" type="checkbox"/> mating connector <input type="checkbox"/> other:_____
Considered current rating of protective device as part of building or equipment installation.....	N/A
Equipment mobility.....	<input type="checkbox"/> movable <input checked="" type="checkbox"/> hand-held <input type="checkbox"/> transportable <input type="checkbox"/> stationary <input type="checkbox"/> for building-in <input type="checkbox"/> direct plug-in <input type="checkbox"/> rack-mounting <input type="checkbox"/> wall-mounted
Over voltage category (OVC)	<input type="checkbox"/> OVC I <input type="checkbox"/> OVC II <input type="checkbox"/> OVC III <input type="checkbox"/> OVC IV <input checked="" type="checkbox"/> other: DC
Class of equipment	<input type="checkbox"/> Class I <input type="checkbox"/> Class II <input checked="" type="checkbox"/> Class III <input type="checkbox"/> Class II with functional earthing <input type="checkbox"/> Not classified
Access location	<input type="checkbox"/> restricted access area <input checked="" type="checkbox"/> N/A
Pollution degree (PD)	<input type="checkbox"/> PD 1 <input checked="" type="checkbox"/> PD 2 <input type="checkbox"/> PD 3
Manufacturer's specified maximum operating ambient	60°C
IP protection class	<input checked="" type="checkbox"/> IP54
Power Systems	<input type="checkbox"/> TN <input type="checkbox"/> TT <input type="checkbox"/> IT - ____ V L-L; <input type="checkbox"/> dc mains <input checked="" type="checkbox"/> N/A
Altitude during operation (m)	<input checked="" type="checkbox"/> 2000 m or less <input type="checkbox"/> ____ m
Altitude of test laboratory (m)	<input checked="" type="checkbox"/> 2000 m or less <input type="checkbox"/> ____ m
Mass of equipment (kg)	<input checked="" type="checkbox"/> 0.02kg

Possible test case verdicts:								
- test case does not apply to the test object: N/A								
- test object does meet the requirement: P (Pass)								
- test object does not meet the requirement: F (Fail)								
Testing								
Date of receipt of test item: 2022-07-11								
Date (s) of performance of tests: 2022-07-18 to 2022-07-28								
General remarks:								
<p>"(See Enclosure #)" refers to additional information appended to the report. "(See appended table)" refers to a table appended to the report.</p> <p>Throughout this report a <input type="checkbox"/> comma / <input checked="" type="checkbox"/> point is used as the decimal separator.</p> <p>TÜV SÜD Limited is a UKAS accredited testing laboratory No. 0141</p> <p>The BT DID & BT HOS DID are powered by an ES1, PS1 coin cell and functional insulation is also used throughout.</p> <ol style="list-style-type: none"> 1. The unit is powered by a primary coin cell only. 2. All accessible circuits are designated ES1. 3. The maximum declared operating ambient (Tma) of the is 65°C. 4. The build state / revision level of the hardware assessed was: V1 5. The user instructions assessed were an English Language version of: "Bluetooth Driver Identification Device (BT DID) Installation Manual", dated 13 January 2023 6. Vehicle specific aspects are not considered under this standard, further assessment to relevant standards may apply <p>Report history</p> <table border="1"> <thead> <tr> <th>Report No.</th> <th>Date</th> <th>Subject of update</th> </tr> </thead> <tbody> <tr> <td>071-75952029-010</td> <td>This report</td> <td>Original assessment</td> </tr> </tbody> </table>			Report No.	Date	Subject of update	071-75952029-010	This report	Original assessment
Report No.	Date	Subject of update						
071-75952029-010	This report	Original assessment						
When differences exist; they shall be identified in the General product information section.								
Name and address of factory (ies)	Barracuda Holdings (Pty) Ltd. Unit 1, Bataleur Park, Olive Grove Industrial Estate, Ou Paardevlei Road, Somerset West, South Africa							
General product information and other remarks:								
Product Description –								
The BT DID (Bluetooth Driver ID) and BT HOS DID (Bluetooth Hours of Service Driver ID) are remote fobs that communicate with the mobile host (e.g. MiX 3000) via a bi-directional Bluetooth LE RF link. It comprises a Green Button which transmits the Driver Identification message in order to identify the driver in the vehicle and a Red Button for Road Side Assist/Panic. The BT HOS DID also supports Hours of Service (HOS) functionality. The BT DID and BT HOS DID have the same function and use the same PCB, electronic components and enclosure, the difference is that the BT HOS DID has an additional memory IC.								
Model Differences –								
BT HOS DID - Bluetooth Driver Identification Device with Hours of Service (HOS) function, remote fob BT DID – Bluetooth Driver Identification Device, remote fob								

Additional application considerations – (Considerations used to test a component or sub-assembly) –

The Hours of Service (HOS) function is not evaluated within this report.

ENERGY SOURCE IDENTIFICATION AND CLASSIFICATION TABLE:	
(Note 1: Identify the following six (6) energy source forms based on the origin of the energy.) (Note 2: The identified classification e.g., ES2, TS1, should be with respect to its ability to cause pain or injury on the body or its ability to ignite a combustible material. Any energy source can be declared Class 3 as a worse case classification e.g. PS3, ES3.)	
Electrically-caused injury (Clause 5): (Note: Identify type of source, list sub-assembly or circuit designation and corresponding energy source classification) Example: +5 V dc input	
	ES1
Source of electrical energy	Corresponding classification (ES)
Coin cell	ES1
Electrically-caused fire (Clause 6): (Note: List sub-assembly or circuit designation and corresponding energy source classification) Example: Battery pack (maximum 85 watts):	
	PS2
Source of power or PIS	Corresponding classification (PS)
Coin cell	PS1
Injury caused by hazardous substances (Clause 7) (Note: Specify hazardous chemicals, whether produces ozone or other chemical construction not addressed as part of the component evaluation.) Example: Liquid in filled component	
	Glycol
Source of hazardous substances	Corresponding chemical
Coin cell	Lithium
Mechanically-caused injury (Clause 8) (Note: List moving part(s), fan, special installations, etc. & corresponding MS classification based on Table 35.) Example: Wall mount unit	
	MS2
Source of kinetic/mechanical energy	Corresponding classification (MS)
Equipment mass	MS1
Edges and corners	MS1
Thermal burn injury (Clause 9) (Note: Identify the surface or support, and corresponding energy source classification based on type of part, location, operating temperature and contact time in Table 38.) Example: Hand-held scanner – thermoplastic enclosure	
	TS1
Source of thermal energy	Corresponding classification (TS)
Accessible surfaces	TS1
Radiation (Clause 10) (Note: List the types of radiation present in the product and the corresponding energy source classification.) Example: DVD – Class 1 Laser Product	
	RS1
Type of radiation	Corresponding classification (RS)
Indicating LED	RS1

ENERGY SOURCE DIAGRAM

Indicate which energy sources are included in the energy source diagram. Insert diagram below

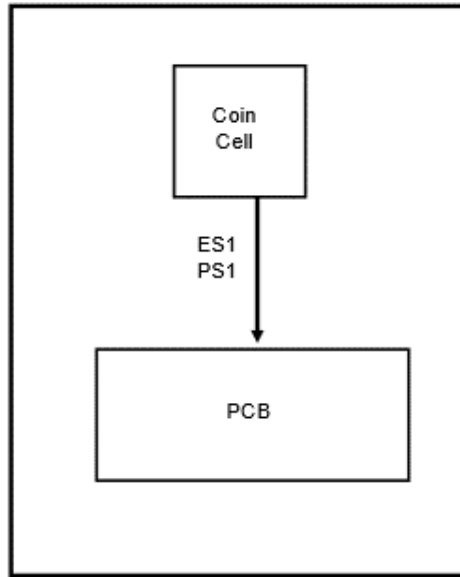

MS1
TS1
RS1

ES PS MS TS RS

OVERVIEW OF EMPLOYED SAFEGUARDS				
Clause	Possible Hazard			
5.1	Electrically-caused injury			
Body Part (e.g. Ordinary)	Energy Source (ES3: Primary Filter circuit)	Safeguards		
		Basic	Supplementary	Reinforced (Enclosure)
Ordinary person	ES1: Coin cell	-	-	-
6.1	Electrically-caused fire			
Material part (e.g. mouse enclosure)	Energy Source (PS2: 100 Watt circuit)	Safeguards		
		Basic	Supplementary	Reinforced
Enclosure	PS1: Coin cell	No ignition or excessive temperature under normal or abnormal conditions, materials outside fire enclosure enclosure HB rated	-	-
7.1	Injury caused by hazardous substances			
Body Part (e.g., skilled)	Energy Source (hazardous material)	Safeguards		
		Basic	Supplementary	Reinforced
Ordinary person	Coin cell (lithium)	-	-	Complies with annex M
8.1	Mechanically-caused injury			
Body Part (e.g. Ordinary)	Energy Source (MS3:High Pressure Lamp)	Safeguards		
		Basic	Supplementary	Reinforced (Enclosure)
Ordinary person	MS1: Equipment mass	<7kg	-	-
Ordinary person	MS1: Edges and corners	No sharp edges or corners	-	-
9.1	Thermal Burn			
Body Part (e.g., Ordinary)	Energy Source (TS2)	Safeguards		
		Basic	Supplementary	Reinforced
Ordinary person	TS1: Accessible surfaces	Plastic surfaces held or touched in normal use	-	-
10.1	Radiation			
Body Part (e.g., Ordinary)	Energy Source (Output from audio port)	Safeguards		
		Basic	Supplementary	Reinforced
Ordinary person	RS1: Indicating LED	Exempt group	-	-
Supplementary Information:				
(1) See attached energy source diagram for additional details.				
(2) "N" – Normal Condition; "A" – Abnormal Condition; "S" Single Fault				

IEC 62368-1			
Clause	Requirement + Test	Result - Remark	Verdict
4	GENERAL REQUIREMENTS		P
4.1.1	Acceptance of materials, components and subassemblies		P
4.1.2	Use of components		P
4.1.3	Equipment design and construction		P
4.1.15	Markings and instructions.....:	(See Annex F)	P
4.4.4	Safeguard robustness		P
4.4.4.2	Steady force tests.....:	(See Annex T.4, T.5)	P
4.4.4.3	Drop tests.....:	(See Annex T.7)	P
4.4.4.4	Impact tests.....:	-	N/A
4.4.4.5	Internal accessible safeguard enclosure and barrier tests.....:	-	N/A
4.4.4.6	Glass Impact tests.....:	-	N/A
4.4.4.7	Thermoplastic material tests.....:	(See Annex T.8)	P
4.4.4.8	Air comprising a safeguard.....:	-	N/A
4.4.4.9	Accessibility and safeguard effectiveness		P
4.5	Explosion		P
4.6	Fixing of conductors		N/A
4.6.1	Fix conductors not to defeat a safeguard		N/A
4.6.2	10 N force test applied to.....:	-	N/A
4.7	Equipment for direct insertion into mains socket - outlets		N/A
4.7.2	Mains plug part complies with the relevant standard.....:	-	N/A
4.7.3	Torque (Nm).....:		N/A
4.8	Products containing coin/button cell batteries		P
4.8.2	Instructional safeguard		P
4.8.3	Battery Compartment Construction		P
	Means to reduce the possibility of children removing the battery.....:	2mm diameter captive screws	—
4.8.4	Battery Compartment Mechanical Tests.....:	(See Table 4.8.4)	P
4.8.5	Battery Accessibility		P
4.9	Likelihood of fire or shock due to entry of conductive object.....:	(See Annex P)	P

IEC 62368-1			
Clause	Requirement + Test	Result - Remark	Verdict

5	ELECTRICALLY-CAUSED INJURY		P
5.2.1	Electrical energy source classifications..... :	(See appended table 5.2)	P
5.2.2	ES1, ES2 and ES3 limits		P
5.2.2.2	Steady-state voltage and current..... :	(See appended table 5.2)	P
5.2.2.3	Capacitance limits	-	N/A
5.2.2.4	Single pulse limits	-	N/A
5.2.2.5	Limits for repetitive pulses	-	N/A
5.2.2.6	Ringling signals	-	N/A
5.2.2.7	Audio signals	-	N/A
5.3	Protection against electrical energy sources	ES1 only	N/A
5.3.1	General Requirements for accessible parts to ordinary, instructed and skilled persons		N/A
5.3.2.1	Accessibility to electrical energy sources and safeguards		N/A
5.3.2.2	Contact requirements		N/A
	a) Test with test probe from Annex V	-	N/A
	b) Electric strength test potential (V)	-	N/A
	c) Air gap (mm)	-	N/A
5.3.2.4	Terminals for connecting stripped wire		N/A
5.4	Insulation materials and requirements		N/A
5.4.1.2	Properties of insulating material		N/A
5.4.1.3	Humidity conditioning	-	N/A
5.4.1.4	Maximum operating temperature for insulating materials	-	N/A
5.4.1.5	Pollution degree	-	—
5.4.1.5.2	Test for pollution degree 1 environment and for an insulating compound		N/A
5.4.1.5.3	Thermal cycling		N/A
5.4.1.6	Insulation in transformers with varying dimensions		N/A
5.4.1.7	Insulation in circuits generating starting pulses		N/A
5.4.1.8	Determination of working voltage		N/A
5.4.1.9	Insulating surfaces		N/A
5.4.1.10	Thermoplastic parts on which conductive metallic parts are directly mounted		N/A
5.4.1.10.2	Vicat softening temperature..... :	-	N/A
5.4.1.10.3	Ball pressure	-	N/A
5.4.2	Clearances		N/A
5.4.2.2	Determining clearance using peak working voltage	-	N/A

IEC 62368-1			
Clause	Requirement + Test	Result - Remark	Verdict
5.4.2.3	Determining clearance using required withstand voltage	-	N/A
	a) a.c. mains transient voltage	-	—
	b) d.c. mains transient voltage	-	—
	c) external circuit transient voltage	-	—
	d) transient voltage determined by measurement ... :	-	—
5.4.2.4	Determining the adequacy of a clearance using an electric strength test	-	N/A
5.4.2.5	Multiplication factors for clearances and test voltages	-	N/A
5.4.3	Creepage distances	-	N/A
5.4.3.1	General		N/A
5.4.3.3	Material Group	-	—
5.4.4	Solid insulation		N/A
5.4.4.2	Minimum distance through insulation	-	N/A
5.4.4.3	Insulation compound forming solid insulation		N/A
5.4.4.4	Solid insulation in semiconductor devices		N/A
5.4.4.5	Cemented joints		N/A
5.4.4.6	Thin sheet material		N/A
5.4.4.6.1	General requirements		N/A
5.4.4.6.2	Separable thin sheet material		N/A
	Number of layers (pcs)	-	N/A
5.4.4.6.3	Non-separable thin sheet material		N/A
5.4.4.6.4	Standard test procedure for non-separable thin sheet material	-	N/A
5.4.4.6.5	Mandrel test		N/A
5.4.4.7	Solid insulation in wound components		N/A
5.4.4.9	Solid insulation at frequencies >30 kHz	-	N/A
5.4.5	Antenna terminal insulation		N/A
5.4.5.1	General		N/A
5.4.5.2	Voltage surge test		N/A
	Insulation resistance (MΩ).....	-	—
5.4.6	Insulation of internal wire as part of supplementary safeguard	-	N/A
5.4.7	Tests for semiconductor components and for cemented joints		N/A
5.4.8	Humidity conditioning		N/A
	Relative humidity (%).....	-	—

IEC 62368-1			
Clause	Requirement + Test	Result - Remark	Verdict
	Temperature (°C)	-	—
	Duration (h)	-	—
5.4.9	Electric strength test	-	N/A
5.4.9.1	Test procedure for a solid insulation type test		N/A
5.4.9.2	Test procedure for routine tests		N/A
5.4.10	Protection against transient voltages between external circuit		N/A
5.4.10.1	Parts and circuits separated from external circuits	-	N/A
5.4.10.2	Test methods		N/A
5.4.10.2.1	General		N/A
5.4.10.2.2	Impulse test	-	N/A
5.4.10.2.3	Steady-state test.....	-	N/A
5.4.11	Insulation between external circuits and earthed circuitry	-	N/A
5.4.11.1	Exceptions to separation between external circuits and earth		N/A
5.4.11.2	Requirements		N/A
	Rated operating voltage U_{op} (V).....	-	—
	Nominal voltage U_{peak} (V).....	-	—
	Max increase due to variation U_{sp}	-	—
	Max increase due to ageing ΔU_{sa}	-	—
	$U_{op} = U_{peak} + \Delta U_{sp} + \Delta U_{sa}$	-	—
5.5	Components as safeguards		N/A
5.5.1	General		N/A
5.5.2	Capacitors and RC units	No such capacitors	N/A
5.5.2.1	General requirement		N/A
5.5.2.2	Safeguards against capacitor discharge after disconnection of a connector.....	-	N/A
5.5.3	Transformers	No such transformers	N/A
5.5.4	Optocouplers	No such optocouplers	N/A
5.5.5	Relays	No such relays	N/A
5.5.6	Resistors	No such resistors	N/A
5.5.7	SPD's	No SPD's	N/A
5.5.7.1	Use of an SPD connected to reliable earthing		N/A
5.5.7.2	Use of an SPD between mains and protective earth		N/A
5.5.8	Insulation between the mains and external circuit consisting of a coaxial cable.....	-	N/A
5.6	Protective conductor		N/A

IEC 62368-1			
Clause	Requirement + Test	Result - Remark	Verdict
5.6.2	Requirement for protective conductors		N/A
5.6.2.1	General requirements		N/A
5.6.2.2	Colour of insulation		N/A
5.6.3	Requirement for protective earthing conductors		N/A
	Protective earthing conductor size (mm ²): -		—
5.6.4	Requirement for protective bonding conductors		N/A
5.6.4.1	Protective bonding conductors		N/A
	Protective bonding conductor size (mm ²).: -		—
	Protective current rating (A) : -		—
5.6.4.3	Current limiting and overcurrent protective devices		N/A
5.6.5	Terminals for protective conductors		N/A
5.6.5.1	Requirement		N/A
	Conductor size (mm ²), nominal thread diameter (mm).: -		N/A
5.6.5.2	Corrosion		N/A
5.6.6	Resistance of the protective system		N/A
5.6.6.1	Requirements		N/A
5.6.6.2	Test Method Resistance (Ω).....: -		N/A
5.6.7	Reliable earthing		N/A
5.7	Prospective touch voltage, touch current and protective conductor current		N/A
5.7.2	Measuring devices and networks		N/A
5.7.2.1	Measurement of touch current: -		N/A
5.7.2.2	Measurement of prospective touch voltage		N/A
5.7.3	Equipment set-up, supply connections and earth connections		N/A
	System of interconnected equipment (separate connections/single connection): -		—
	Multiple connections to mains (one connection at a time/simultaneous connections): -		—
5.7.4	Earthed conductive accessible parts: -		N/A
5.7.5	Protective conductor current		N/A
	Supply Voltage (V).....: -		—
	Measured current (mA).....: -		—
	Instructional Safeguard.....: -		N/A
5.7.6	Prospective touch voltage and touch current due to external circuits		N/A
5.7.6.1	Touch current from coaxial cables		N/A

IEC 62368-1			
Clause	Requirement + Test	Result - Remark	Verdict
5.7.6.2	Prospective touch voltage and touch current from external circuits		N/A
5.7.7	Summation of touch currents from external circuits		N/A
	a) Equipment with earthed external circuits Measured current (mA)..... :	-	N/A
	b) Equipment whose external circuits are not referenced to earth. Measured current (mA) :	-	N/A

6	ELECTRICALLY- CAUSED FIRE		P
6.2	Classification of power sources (PS) and potential ignition sources (PIS)		P
6.2.2	Power source circuit classifications		P
6.2.2.1	General		P
6.2.2.2	Power measurement for worst-case load fault ... :	(See appended table 6.2.2)	P
6.2.2.3	Power measurement for worst-case power source fault :	(See appended table 6.2.2)	P
6.2.2.4	PS1 :	(See appended table 6.2.2)	P
6.2.2.5	PS2 :	-	N/A
6.2.2.6	PS3 :	-	N/A
6.2.3	Classification of potential ignition sources		P
6.2.3.1	Arcing PIS :	(See appended table 6.2.3.1)	P
6.2.3.2	Resistive PIS :	(See appended table 6.2.3.2)	P
6.3	Safeguards against fire under normal operating and abnormal operating conditions		P
6.3.1 (a)	No ignition and attainable temperature value less than 90 % defined by ISO 871 or less than 300 °C for unknown materials :	(See appended table 5.4.1.5, 6.3.2, 9.0, B.2.6)	P
6.3.1 (b)	Combustible materials outside fire enclosure		P
6.4	Safeguards against fire under single fault conditions		P
6.4.1	Safeguard Method	Control fire spread	P
6.4.2	Reduction of the likelihood of ignition under single fault conditions in PS1 circuits		N/A
6.4.3	Reduction of the likelihood of ignition under single fault conditions in PS2 and PS3 circuits		N/A
6.4.3.1	General		N/A
6.4.3.2	Supplementary Safeguards		N/A
	Special conditions if conductors on printed boards are opened or peeled		N/A
6.4.3.3	Single Fault Conditions :	-	N/A
	Special conditions for temperature limited by fuse		N/A
6.4.4	Control of fire spread in PS1 circuits		P

IEC 62368-1			
Clause	Requirement + Test	Result - Remark	Verdict
6.4.5	Control of fire spread in PS2 circuits		N/A
6.4.5.2	Supplementary safeguards	-	N/A
6.4.6	Control of fire spread in PS3 circuit		N/A
6.4.7	Separation of combustible materials from a PIS		N/A
6.4.7.1	General.....	-	N/A
6.4.7.2	Separation by distance		N/A
6.4.7.3	Separation by a fire barrier		N/A
6.4.8	Fire enclosures and fire barriers		N/A
6.4.8.1	Fire enclosure and fire barrier material properties		N/A
6.4.8.2.1	Requirements for a fire barrier		N/A
6.4.8.2.2	Requirements for a fire enclosure		N/A
6.4.8.3	Constructional requirements for a fire enclosure and a fire barrier		n/a
6.4.8.3.1	Fire enclosure and fire barrier openings		N/A
6.4.8.3.2	Fire barrier dimensions		N/A
6.4.8.3.3	Top Openings in Fire Enclosure: dimensions (mm)	-	N/A
	Needle Flame test		N/A
6.4.8.3.4	Bottom Openings in Fire Enclosure, condition met a), b) and/or c) dimensions (mm)	-	N/A
	Flammability tests for the bottom of a fire enclosure	-	N/A
6.4.8.3.5	Integrity of the fire enclosure, condition met: a), b) or c)	-	N/A
6.4.8.4	Separation of PIS from fire enclosure and fire barrier distance (mm) or flammability rating.....	-	N/A
6.5	Internal and external wiring		N/A
6.5.1	Requirements	No wiring	N/A
6.5.2	Cross-sectional area (mm ²)	-	—
6.5.3	Requirements for interconnection to building wiring	-	N/A
6.6	Safeguards against fire due to connection to additional equipment		N/A
	External port limited to PS2 or complies with Clause Q.1		N/A

IEC 62368-1			
Clause	Requirement + Test	Result - Remark	Verdict

7	INJURY CAUSED BY HAZARDOUS SUBSTANCES		P
7.2	Reduction of exposure to hazardous substances		N/A
7.3	Ozone exposure		N/A
7.4	Use of personal safeguards (PPE)		N/A
	Personal safeguards and instructions	-	—
7.5	Use of instructional safeguards and instructions		N/A
	Instructional safeguard (ISO 7010)	-	—
7.6	Batteries.....	(See Annex M)	P

8	MECHANICALLY-CAUSED INJURY		P
8.1	General		P
8.2	Mechanical energy source classifications		P
8.3	Safeguards against mechanical energy sources		P
8.4	Safeguards against parts with sharp edges and corners	No sharp edges or corners	P
8.4.1	Safeguards		N/A
8.5	Safeguards against moving parts	No moving parts	N/A
8.5.1	MS2 or MS3 part required to be accessible for the function of the equipment		N/A
8.5.2	Instructional Safeguard	-	—
8.5.4	Special categories of equipment comprising moving parts		N/A
8.5.4.1	Large data storage equipment		N/A
8.5.4.2	Equipment having electromechanical device for destruction of media		N/A
8.5.4.2.1	Safeguards and Safety Interlocks	-	N/A
8.5.4.2.2	Instructional safeguards against moving parts		N/A
	Instructional Safeguard	-	—
8.5.4.2.3	Disconnection from the supply		N/A
8.5.4.2.4	Probe type and force (N)	-	N/A
8.5.5	High Pressure Lamps		N/A
8.5.5.1	Energy Source Classification		N/A
8.5.5.2	High Pressure Lamp Explosion Test.....	-	N/A
8.6	Stability		N/A
8.6.1	Product classification		N/A
	Instructional Safeguard	-	—

IEC 62368-1			
Clause	Requirement + Test	Result - Remark	Verdict
8.6.2	Static stability		N/A
8.6.2.2	Static stability test		N/A
	Applied Force	-	—
8.6.2.3	Downward Force Test		N/A
8.6.3	Relocation stability test		N/A
	Unit configuration during 10° tilt.....	-	—
8.6.4	Glass slide test		N/A
8.6.5	Horizontal force test (Applied Force).....	-	N/A
	Position of feet or movable parts.....	-	—
8.7	Equipment mounted to wall or ceiling	Not for wall mounting	N/A
8.7.1	Mounting Means (Length of screws (mm) and mounting surface)	-	N/A
8.7.2	Direction and applied force.....	-	N/A
8.8	Handles strength	No handles	N/A
8.8.1	Classification		N/A
8.8.2	Applied Force	-	N/A
8.9	Wheels or casters attachment requirements	No wheels or casters	N/A
8.9.1	Classification		N/A
8.9.2	Applied force	-	—
8.10	Carts, stands and similar carriers		N/A
8.10.1	General		N/A
8.10.2	Marking and instructions		N/A
	Instructional Safeguard.....	-	—
8.10.3	Cart, stand or carrier loading test and compliance		N/A
	Applied force	-	—
8.10.4	Cart, stand or carrier impact test		N/A
8.10.5	Mechanical stability		N/A
	Applied horizontal force (N).....	-	—
8.10.6	Thermoplastic temperature stability (°C).....	-	N/A
8.11	Mounting means for rack mounted equipment		N/A
8.11.1	General		N/A
8.11.2	Product Classification		N/A
8.11.3	Mechanical strength test, variable <i>N</i>	-	N/A
8.11.4	Mechanical strength test 250N, including end stops		N/A
8.12	Telescoping or rod antennas.....	-	N/A
	Button/Ball diameter (mm).....	-	—

IEC 62368-1			
Clause	Requirement + Test	Result - Remark	Verdict
9	THERMAL BURN INJURY		P
9.2	Thermal energy source classifications		P
9.3	Safeguard against thermal energy sources		N/A
9.4	Requirements for safeguards		N/A
9.4.1	Equipment safeguard		N/A
9.4.2	Instructional safeguard	-	N/A

10	RADIATION		P
10.2	Radiation energy source classification	RS1	P
10.2.1	General classification		P
10.3	Protection against laser radiation	No lasers	N/A
	Laser radiation that exists in the equipment:		—
	Normal, abnormal, single-fault.....	-	N/A
	Instructional safeguard	-	—
	Tool.....	-	—
10.4	Protection against visible, infrared, and UV radiation	Indicating LED's only	P
10.4.1	General		P
10.4.1.a)	RS3 for Ordinary and instructed persons	-	N/A
10.4.1.b)	RS3 accessible to a skilled person.....	-	N/A
	Personal safeguard (PPE) instructional safeguard.....	-	—
10.4.1.c)	Equipment visible, IR, UV does not exceed RS1 . :		P
10.4.1.d)	Normal, abnormal, single-fault conditions	-	N/A
10.4.1.e)	Enclosure material employed as safeguard is opaque.....	-	N/A
10.4.1.f)	UV attenuation	-	N/A
10.4.1.g)	Materials resistant to degradation UV	-	N/A
10.4.1.h)	Enclosure containment of optical radiation.....	-	N/A
10.4.1.i)	Exempt Group under normal operating conditions.....	Indicating LED's only	P
10.4.2	Instructional safeguard	-	N/A
10.5	Protection against x-radiation		N/A
10.5.1	X- radiation energy source that exists equipment :	-	N/A
	Normal, abnormal, single fault conditions		N/A
	Equipment safeguards.....	-	N/A
	Instructional safeguard for skilled person.....	-	N/A
10.5.3	Most unfavourable supply voltage to give		—

IEC 62368-1			
Clause	Requirement + Test	Result - Remark	Verdict
	maximum radiation	-	
	Abnormal and single-fault condition	-	N/A
	Maximum radiation (pA/kg).....		N/A
10.6	Protection against acoustic energy sources	No acoustic energy sources	N/A
10.6.1	General		N/A
10.6.2	Classification		N/A
	Acoustic output, dB(A)	-	N/A
	Output voltage, unweighted r.m.s.....	-	N/A
10.6.4	Protection of persons		N/A
	Instructional safeguards	-	N/A
	Equipment safeguard prevent ordinary person to RS2	-	—
	Means to actively inform user of increase sound pressure.....	-	—
	Equipment safeguard prevent ordinary person to RS2.....	-	—
10.6.5	Requirements for listening devices (headphones, earphones, etc.)		N/A
10.6.5.1	Corded passive listening devices with analog input		N/A
	Input voltage with 94 dB(A) L_{Aeq} acoustic pressure output.....	-	—
10.6.5.2	Corded listening devices with digital input		N/A
	Maximum dB(A)	-	—
10.6.5.3	Cordless listening device		N/A
	Maximum dB(A)	-	—

B	NORMAL OPERATING CONDITION TESTS, ABNORMAL OPERATING CONDITION TESTS AND SINGLE FAULT CONDITION TESTS		P
B.2	Normal Operating Conditions		P
B.2.1	General requirements.....	(See Test Item Particulars and appended test tables)	P
	Audio Amplifiers and equipment with audio amplifiers	-	N/A
B.2.3	Supply voltage and tolerances		P
B.2.5	Input test.....	Primary coin cell only	N/A
B.3	Simulated abnormal operating conditions		P
B.3.1	General requirements.....	(See appended table B.3)	P
B.3.2	Covering of ventilation openings		N/A
B.3.3	D.C. mains polarity test		N/A

IEC 62368-1			
Clause	Requirement + Test	Result - Remark	Verdict
B.3.4	Setting of voltage selector	-	N/A
B.3.5	Maximum load at output terminals	-	N/A
B.3.6	Reverse battery polarity		P
B.3.7	Abnormal operating conditions as specified in Clause E.2.		N/A
B.3.8	Safeguards functional during and after abnormal operating conditions		N/A
B.4	Simulated single fault conditions		P
B.4.2	Temperature controlling device open or short-circuited	-	N/A
B.4.3	Motor tests	No motors	N/A
B.4.3.1	Motor blocked or rotor locked increasing the internal ambient temperature	-	N/A
B.4.4	Short circuit of functional insulation		P
B.4.4.1	Short circuit of clearances for functional insulation		P
B.4.4.2	Short circuit of creepage distances for functional insulation		P
B.4.4.3	Short circuit of functional insulation on coated printed boards		N/A
B.4.5	Short circuit and interruption of electrodes in tubes and semiconductors		N/A
B.4.6	Short circuit or disconnect of passive components		P
B.4.7	Continuous operation of components		P
B.4.8	Class 1 and Class 2 energy sources within limits during and after single fault conditions		P
B.4.9	Battery charging under single fault conditions ... :	Battery is primary power source	N/A
C	UV RADIATION		N/A
C.1	Protection of materials in equipment from UV radiation		N/A
C.1.2	Requirements		N/A
C.1.3	Test method		N/A
C.2	UV light conditioning test		N/A
C.2.1	Test apparatus		N/A
C.2.2	Mounting of test samples		N/A
C.2.3	Carbon-arc light-exposure apparatus		N/A
C.2.4	Xenon-arc light exposure apparatus		N/A
D	TEST GENERATORS		N/A
D.1	Impulse test generators		N/A
D.2	Antenna interface test generator		N/A
D.3	Electronic pulse generator		N/A

IEC 62368-1			
Clause	Requirement + Test	Result - Remark	Verdict
E	TEST CONDITIONS FOR EQUIPMENT CONTAINING AUDIO AMPLIFIERS		N/A
E.1	Audio amplifier normal operating conditions		N/A
	Audio signal voltage (V)	-	—
	Rated load impedance (Ω)	-	—
E.2	Audio amplifier abnormal operating conditions		N/A
F	EQUIPMENT MARKINGS, INSTRUCTIONS, AND INSTRUCTIONAL SAFEGUARDS		P
F.1	General requirements		P
	Instructions – Language	English only	—
F.2	Letter symbols and graphical symbols		P
F.2.1	Letter symbols according to IEC60027-1		P
F.2.2	Graphic symbols IEC, ISO or manufacturer specific		P
F.3	Equipment markings		P
F.3.1	Equipment marking locations		P
F.3.2	Equipment identification markings		P
F.3.2.1	Manufacturer identification	MiX TELEMATICS	—
F.3.2.2	Model identification	BT DID, BT HOS DID	—
F.3.3	Equipment rating markings	Primary coin cell powered	N/A
F.3.3.1	Equipment with direct connection to mains		N/A
F.3.3.2	Equipment without direct connection to mains		N/A
F.3.3.3	Nature of supply voltage.....	-	—
F.3.3.4	Rated voltage	-	—
F.3.3.5	Rated frequency	-	—
F.3.3.6	Rated current or rated power	-	—
F.3.3.7	Equipment with multiple supply connections		N/A
F.3.4	Voltage setting device		N/A
F.3.5	Terminals and operating devices		N/A
F.3.5.1	Mains appliance outlet and socket-outlet markings.....	-	N/A
F.3.5.2	Switch position identification marking	-	N/A
F.3.5.3	Replacement fuse identification and rating markings.....	-	N/A
F.3.5.4	Replacement battery identification marking	-	N/A
F.3.5.5	Terminal marking location		N/A
F.3.6	Equipment markings related to equipment classification		N/A
F.3.6.1	Class I Equipment		N/A
F.3.6.1.1	Protective earthing conductor terminal		N/A

IEC 62368-1			
Clause	Requirement + Test	Result - Remark	Verdict
F.3.6.1.2	Neutral conductor terminal		N/A
F.3.6.1.3	Protective bonding conductor terminals		N/A
F.3.6.2	Class II equipment (IEC60417-5172)		N/A
F.3.6.2.1	Class II equipment with or without functional earth		N/A
F.3.6.2.2	Class II equipment with functional earth terminal marking		N/A
F.3.7	Equipment IP rating marking	IP54	—
F.3.8	External power supply output marking		N/A
F.3.9	Durability, legibility and permanence of marking		P
F.3.10	Test for permanence of markings		P
F.4	Instructions		P
	a) Equipment for use in locations where children not likely to be present - marking	Not evaluated using probe V.2	N/A
	b) Instructions given for installation or initial use		P
	c) Equipment intended to be fastened in place		P
	d) Equipment intended for use only in restricted access area		N/A
	e) Audio equipment terminals classified as ES3 and other equipment with terminals marked in accordance F.3.6.1		N/A
	f) Protective earthing employed as safeguard		N/A
	g) Protective earthing conductor current exceeding ES 2 limits		N/A
	h) Symbols used on equipment		N/A
	i) Permanently connected equipment not provided with all-pole mains switch		N/A
	j) Replaceable components or modules providing safeguard function		N/A
F.5	Instructional safeguards		P
	Where “instructional safeguard” is referenced in the test report it specifies the required elements, location of marking and/or instruction		P
G	COMPONENTS		N/A
G.1	Switches		N/A
G.1.1	General requirements		N/A
G.1.2	Ratings, endurance, spacing, maximum load		N/A
G.2	Relays		N/A
G.2.1	General requirements		N/A
G.2.2	Overload test		N/A
G.2.3	Relay controlling connectors supply power		N/A

IEC 62368-1			
Clause	Requirement + Test	Result - Remark	Verdict
G.2.4	Mains relay, modified as stated in G.2		N/A
G.3	Protection Devices		N/A
G.3.1	Thermal cut-offs		N/A
G.3.1.1a) &b)	Thermal cut-outs separately approved according to IEC 60730 with conditions indicated in a) & b)		N/A
G.3.1.1c)	Thermal cut-outs tested as part of the equipment as indicated in c)		N/A
G.3.1.2	Thermal cut-off connections maintained and secure		N/A
G.3.2	Thermal links		N/A
G.3.2.1a)	Thermal links separately tested with IEC 60691		N/A
G.3.2.1b)	Thermal links tested as part of the equipment		N/A
	Aging hours (H) : -		—
	Single Fault Condition : -		—
	Test Voltage (V) and Insulation Resistance (Ω). : -		—
G.3.3	PTC Thermistors		N/A
G.3.4	Overcurrent protection devices		N/A
G.3.5	Safeguards components not mentioned in G.3.1 to G.3.5		N/A
G.3.5.1	Non-resettable devices suitably rated and marking provided		N/A
G.3.5.2	Single faults conditions..... : -		N/A
G.4	Connectors		N/A
G.4.1	Spacings		N/A
G.4.2	Mains connector configuration : -		N/A
G.4.3	Plug is shaped that insertion into mains socket-outlets or appliance coupler is unlikely		N/A
G.5	Wound Components		N/A
G.5.1	Wire insulation in wound components..... : -		N/A
G.5.1.2 a)	Two wires in contact inside wound component, angle between 45° and 90°		N/A
G.5.1.2 b)	Construction subject to routine testing		N/A
G.5.2	Endurance test on wound components		N/A
G.5.2.1	General test requirements		N/A
G.5.2.2	Heat run test		N/A
	Time (s) : -		—
	Temperature (°C) : -		—
G.5.2.3	Wound Components supplied by mains		N/A
G.5.3	Transformers		N/A

IEC 62368-1			
Clause	Requirement + Test	Result - Remark	Verdict
G.5.3.1	Requirements applied (IEC61204-7, IEC61558-1/-2, and/or IEC62368-1)..... :	-	N/A
	Position..... :	-	—
	Method of protection	-	—
G.5.3.2	Insulation		N/A
	Protection from displacement of windings..... :	-	—
G.5.3.3	Overload test	-	N/A
G.5.3.3.1	Test conditions		N/A
G.5.3.3.2	Winding Temperatures testing in the unit		N/A
G.5.3.3.3	Winding Temperatures - Alternative test method		N/A
G.5.4	Motors		N/A
G.5.4.1	General requirements		N/A
	Position	-	—
G.5.4.2	Test conditions		N/A
G.5.4.3	Running overload test		N/A
G.5.4.4	Locked-rotor overload test		N/A
	Test duration (days)	-	—
G.5.4.5	Running overload test for d.c. motors in secondary circuits		N/A
G.5.4.5.2	Tested in the unit		N/A
	Electric strength test (V)	-	—
G.5.4.5.3	Tested on the Bench - Alternative test method; test time (h)	-	N/A
	Electric strength test (V)	-	—
G.5.4.6	Locked-rotor overload test for d.c. motors in secondary circuits		N/A
G.5.4.6.2	Tested in the unit		N/A
	Maximum Temperature	-	N/A
	Electric strength test (V)	-	N/A
G.5.4.6.3	Tested on the bench - Alternative test method; test time (h)	-	N/A
	Electric strength test (V)	-	N/A
G.5.4.7	Motors with capacitors		N/A
G.5.4.8	Three-phase motors		N/A
G.5.4.9	Series motors		N/A
	Operating voltage	-	—
G.6	Wire Insulation		N/A
G.6.1	General		N/A

IEC 62368-1			
Clause	Requirement + Test	Result - Remark	Verdict
G.6.2	Solvent-based enamel wiring insulation		N/A
G.7	Mains supply cords		N/A
G.7.1	General requirements		N/A
	Type.....: -		—
	Rated current (A).....: -		—
	Cross-sectional area (mm ²), (AWG).....: -		—
G.7.2	Compliance and test method		N/A
G.7.3	Cord anchorages and strain relief for non-detachable power supply cords		N/A
G.7.3.2	Cord strain relief		N/A
G.7.3.2.1	Requirements		N/A
	Strain relief test force (N): -		—
G.7.3.2.2	Strain relief mechanism failure		N/A
G.7.3.2.3	Cord sheath or jacket position, distance (mm).....: -		—
G.7.3.2.4	Strain relief comprised of polymeric material		N/A
G.7.4	Cord Entry: -		N/A
G.7.5	Non-detachable cord bend protection		N/A
G.7.5.1	Requirements		N/A
G.7.5.2	Mass (g): -		—
	Diameter (m): -		—
	Temperature (°C): -		—
G.7.6	Supply wiring space		N/A
G.7.6.2	Stranded wire		N/A
G.7.6.2.1	Test with 8 mm strand		N/A
G.8	Varistors		N/A
G.8.1	General requirements		N/A
G.8.2	Safeguard against shock		N/A
G.8.3	Safeguard against fire		N/A
G.8.3.2	Varistor overload test: -		N/A
G.8.3.3	Temporary overvoltage: -		N/A
G.9	Integrated Circuit (IC) Current Limiters		N/A
G.9.1 a)	Manufacturer defines limit at max. 5A.		N/A
G.9.1 b)	Limiters do not have manual operator or reset		N/A
G.9.1 c)	Supply source does not exceed 250 VA: -		—
G.9.1 d)	IC limiter output current (max. 5A): -		—
G.9.1 e)	Manufacturers' defined drift: -		—
G.9.2	Test Program 1		N/A

IEC 62368-1			
Clause	Requirement + Test	Result - Remark	Verdict
G.9.3	Test Program 2		N/A
G.9.4	Test Program 3		N/A
G.10	Resistors		N/A
G.10.1	General requirements		N/A
G.10.2	Resistor test		N/A
G.10.3	Test for resistors serving as safeguards between the mains and an external circuit consisting of a coaxial cable		N/A
G.10.3.1	General requirements		N/A
G.10.3.2	Voltage surge test		N/A
G.10.3.3	Impulse test		N/A
G.11	Capacitor and RC units		N/A
G.11.1	General requirements		N/A
G.11.2	Conditioning of capacitors and RC units		N/A
G.11.3	Rules for selecting capacitors		N/A
G.12	Optocouplers		N/A
	Optocouplers comply with IEC 60747-5-5:2007 Spacing or Electric Strength Test (specify option and test results)	-	N/A
	Type test voltage Vini	-	—
	Routine test voltage, Vini,b	-	—
G.13	Printed boards		N/A
G.13.1	General requirements		N/A
G.13.2	Uncoated printed boards		N/A
G.13.3	Coated printed boards		N/A
G.13.4	Insulation between conductors on the same inner surface		N/A
	Compliance with cemented joint requirements (Specify construction)	-	—
G.13.5	Insulation between conductors on different surfaces		N/A
	Distance through insulation	-	N/A
	Number of insulation layers (pcs)	-	—
G.13.6	Tests on coated printed boards		N/A
G.13.6.1	Sample preparation and preliminary inspection		N/A
G.13.6.2a)	Thermal conditioning		N/A
G.13.6.2b)	Electric strength test		N/A
G.13.6.2c)	Abrasion resistance test		N/A
G.14	Coating on components terminals		N/A

IEC 62368-1			
Clause	Requirement + Test	Result - Remark	Verdict
G.14.1	Requirements	(See G.13)	N/A
G.15	Liquid filled components		N/A
G.15.1	General requirements		N/A
G.15.2	Requirements		N/A
G.15.3	Compliance and test methods		N/A
G.15.3.1	Hydrostatic pressure test		N/A
G.15.3.2	Creep resistance test		N/A
G.15.3.3	Tubing and fittings compatibility test		N/A
G.15.3.4	Vibration test		N/A
G.15.3.5	Thermal cycling test		N/A
G.15.3.6	Force test		N/A
G.15.4	Compliance		N/A
G.16	IC including capacitor discharge function (ICX)		N/A
a)	Humidity treatment in accordance with sc 5.4.8 – 120 hours		N/A
b)	Impulse test using circuit 2 with $U_c =$ to transient voltage	-	N/A
C1)	Application of ac voltage at 110% of rated voltage for 2.5 minutes		N/A
C2)	Test voltage	-	—
D1)	10,000 cycles on and off using capacitor with smallest capacitance resistor with largest resistance specified by manufacturer		N/A
D2)	Capacitance	-	—
D3)	Resistance	-	—
H	CRITERIA FOR TELEPHONE RINGING SIGNALS		N/A
H.1	General		N/A
H.2	Method A		N/A
H.3	Method B		N/A
H.3.1	Ringling signal		N/A
H.3.1.1	Frequency (Hz)	-	—
H.3.1.2	Voltage (V)	-	—
H.3.1.3	Cadence; time (s) and voltage (V)	-	—
H.3.1.4	Single fault current (mA):.....	-	—
H.3.2	Tripping device and monitoring voltage	-	N/A
H.3.2.1	Conditions for use of a tripping device or a monitoring voltage complied with		N/A
H.3.2.2	Tripping device		N/A
H.3.2.3	Monitoring voltage (V)	-	—

IEC 62368-1			
Clause	Requirement + Test	Result - Remark	Verdict
J	INSULATED WINDING WIRES FOR USE WITHOUT INTERLEAVED INSULATION		N/A
	General requirements	-	N/A
K	SAFETY INTERLOCKS		N/A
K.1	General requirements		N/A
K.2	Components of safety interlock safeguard mechanism	-	N/A
K.3	Inadvertent change of operating mode		N/A
K.4	Interlock safeguard override		N/A
K.5	Fail-safe		N/A
	Compliance	-	N/A
K.6	Mechanically operated safety interlocks		N/A
K.6.1	Endurance requirement		N/A
K.6.2	Compliance and Test method	-	N/A
K.7	Interlock circuit isolation		N/A
K.7.1	Separation distance for contact gaps & interlock circuit elements (type and circuit location)	-	N/A
K.7.2	Overload test, Current (A)	-	N/A
K.7.3	Endurance test		N/A
K.7.4	Electric strength test	-	N/A
L	DISCONNECT DEVICES		N/A
L.1	General requirements		N/A
L.2	Permanently connected equipment		N/A
L.3	Parts that remain energized		N/A
L.4	Single phase equipment		N/A
L.5	Three-phase equipment		N/A
L.6	Switches as disconnect devices		N/A
L.7	Plugs as disconnect devices		N/A
L.8	Multiple power sources		N/A
M	EQUIPMENT CONTAINING BATTERIES AND THEIR PROTECTION CIRCUITS		P
M.1	General requirements		P
M.2	Safety of batteries and their cells		P
M.2.1	Requirements		P
M.2.2	Compliance and test method (identify method) .. :	Manufacturers data	P
M.3	Protection circuits		P
M.3.1	Requirements		P
M.3.2	Tests		P
	- Overcharging of a rechargeable battery		N/A

IEC 62368-1			
Clause	Requirement + Test	Result - Remark	Verdict
	- Unintentional charging of a non-rechargeable battery	Coin cell is primary power source	N/A
	- Reverse charging of a rechargeable battery		N/A
	- Excessive discharging rate for any battery		P
M.3.3	Compliance	(See appended Tables and Annex M.3 and M.4)	P
M.4	Additional safeguards for equipment containing secondary lithium battery	Primary battery only	N/A
M.4.1	General		N/A
M.4.2	Charging safeguards		N/A
M.4.2.1	Charging operating limits		N/A
M.4.2.2a)	Charging voltage, current and temperature	-	—
M.4.2.2 b)	Single faults in charging circuitry	-	—
M.4.3	Fire Enclosure		P
M.4.4	Endurance of equipment containing a secondary lithium battery	Movable equipment	N/A
M.4.4.2	Preparation		N/A
M.4.4.3	Drop and charge/discharge function tests		N/A
	Drop		N/A
	Charge		N/A
	Discharge		N/A
M.4.4.4	Charge-discharge cycle test		N/A
M.4.4.5	Result of charge-discharge cycle test		N/A
M.5	Risk of burn due to short circuit during carrying		N/A
M.5.1	Requirement		N/A
M.5.2	Compliance and Test Method (Test of P.2.3)		N/A
M.6	Prevention of short circuits and protection from other effects of electric current		N/A
M.6.1	Short circuits		N/A
M.6.1.1	General requirements		N/A
M.6.1.2	Test method to simulate an internal fault		N/A
M.6.1.3	Compliance (Specify M.6.1.2 or alternative method)	-	N/A
M.6.2	Leakage current (mA)	-	N/A
M.7	Risk of explosion from lead acid and NiCd batteries		N/A
M.7.1	Ventilation preventing explosive gas concentration		N/A
M.7.2	Compliance and test method		N/A

IEC 62368-1			
Clause	Requirement + Test	Result - Remark	Verdict
M.8	Protection against internal ignition from external spark sources of lead acid batteries		N/A
M.8.1	General requirements		N/A
M.8.2	Test method		N/A
M.8.2.1	General requirements		N/A
M.8.2.2	Estimation of hypothetical volume V_z (m ³ /s)..... :	-	—
M.8.2.3	Correction factors..... :	-	—
M.8.2.4	Calculation of distance d (mm) :	-	—
M.9	Preventing electrolyte spillage		N/A
M.9.1	Protection from electrolyte spillage		N/A
M.9.2	Tray for preventing electrolyte spillage		N/A
M.10	Instructions to prevent reasonably foreseeable misuse (Determination of compliance: inspection, data review; or abnormal testing) :	Safeguard	P
N	ELECTROCHEMICAL POTENTIALS		N/A
	Metal(s) used :	-	—
O	MEASUREMENT OF CREEPAGE DISTANCES AND CLEARANCES		N/A
	Figures O.1 to O.20 of this Annex applied..... :	-	—
P	SAFEGUARDS AGAINST ENTRY OF FOREIGN OBJECTS AND SPILLAGE OF INTERNAL LIQUIDS		P
P.1	General requirements		P
P.2.2	Safeguards against entry of foreign object	No openings in enclosure	P
	Location and Dimensions (mm) :		—
P.2.3	Safeguard against the consequences of entry of foreign object		N/A
P.2.3.1	Safeguards against the entry of a foreign object		N/A
	Openings in transportable equipment		N/A
	Transportable equipment with metalized plastic parts :	-	N/A
P.2.3.2	Openings in transportable equipment in relation to metallized parts of a barrier or enclosure (identification of supplementary safeguard) :	-	N/A
P.3	Safeguards against spillage of internal liquids		N/A
P.3.1	General requirements		N/A
P.3.2	Determination of spillage consequences		N/A
P.3.3	Spillage safeguards		N/A
P.3.4	Safeguards effectiveness		N/A
P.4	Metallized coatings and adhesive securing parts		N/A
P.4.2 a)	Conditioning testing		N/A

IEC 62368-1			
Clause	Requirement + Test	Result - Remark	Verdict
	Tc (°C).....: -		—
	Tr (°C): -		—
	Ta (°C).....: -		—
P.4.2 b)	Abrasion testing: -		N/A
P.4.2 c)	Mechanical strength testing: -		N/A
Q	CIRCUITS INTENDED FOR INTERCONNECTION WITH BUILDING WIRING		N/A
Q.1	Limited power sources		N/A
Q.1.1 a)	Inherently limited output		N/A
Q.1.1 b)	Impedance limited output		N/A
	- Regulating network limited output under normal operating and simulated single fault condition		N/A
Q.1.1 c)	Overcurrent protective device limited output		N/A
Q.1.1 d)	IC current limiter complying with G.9		N/A
Q.1.2	Compliance and test method		N/A
Q.2	Test for external circuits – paired conductor cable		N/A
	Maximum output current (A): -		—
	Current limiting method.....: -		—
R	LIMITED SHORT CIRCUIT TEST		N/A
R.1	General requirements		N/A
R.2	Determination of the overcurrent protective device and circuit		N/A
R.3	Test method Supply voltage (V) and short-circuit current (A).: -		N/A
S	TESTS FOR RESISTANCE TO HEAT AND FIRE		N/A
S.1	Flammability test for fire enclosures and fire barrier materials of equipment where the steady state power does not exceed 4 000 W		N/A
	Samples, material: -		—
	Wall thickness (mm).....: -		—
	Conditioning (°C).....: -		—
	Test flame according to IEC 60695-11-5 with conditions as set out		N/A
	- Material not consumed completely		N/A
	- Material extinguishes within 30s		N/A
	- No burning of layer or wrapping tissue		N/A
S.2	Flammability test for fire enclosure and fire barrier integrity		N/A
	Samples, material: -		—
	Wall thickness (mm).....: -		—

IEC 62368-1			
Clause	Requirement + Test	Result - Remark	Verdict
	Conditioning (°C).....:	-	—
	Test flame according to IEC 60695-11-5 with conditions as set out		N/A
	Test specimen does not show any additional hole		N/A
S.3	Flammability test for the bottom of a fire enclosure		N/A
	Samples, material	-	—
	Wall thickness (mm).....:	-	—
	Cheesecloth did not ignite		N/A
S.4	Flammability classification of materials		N/A
S.5	Flammability test for fire enclosure materials of equipment with a steady-state power exceeding 4000 W		N/A
	Samples, material	-	—
	Wall thickness (mm).....:	-	—
	Conditioning (test condition), (°C).....:	-	—
	Test flame according to IEC 60695-11-20 with conditions as set out		N/A
	After every test specimen was not consumed completely		N/A
	After fifth flame application, flame extinguished within 1 min		N/A
T	MECHANICAL STRENGTH TESTS		P
T.1	General requirements		P
T.2	Steady force test, 10 N	-	N/A
T.3	Steady force test, 30 N	-	N/A
T.4	Steady force test, 100 N	-	N/A
T.5	Steady force test, 250 N	(See appended table T.5)	P
T.6	Enclosure impact test	-	N/A
	Fall test		N/A
	Swing test		N/A
T.7	Drop test	(See appended table T.7)	P
T.8	Stress relief test	(See appended table T.8)	P
T.9	Impact Test (glass)		N/A
T.9.1	General requirements		N/A
T.9.2	Impact test and compliance		N/A
	Impact energy (J).....:	-	—
	Height (m)	-	—

IEC 62368-1			
Clause	Requirement + Test	Result - Remark	Verdict
T.10	Glass fragmentation test	-	N/A
T.11	Test for telescoping or rod antennas		N/A
	Torque value (Nm)	-	—
U	MECHANICAL STRENGTH OF CATHODE RAY TUBES (CRT) AND PROTECTION AGAINST THE EFFECTS OF IMPLOSION		N/A
U.1	General requirements		N/A
U.2	Compliance and test method for non-intrinsically protected CRTs		N/A
U.3	Protective Screen.....	-	N/A
V	DETERMINATION OF ACCESSIBLE PARTS (FINGERS, PROBES AND WEDGES)		N/A
V.1	Accessible parts of equipment		N/A
V.2	Accessible part criterion		N/A

IEC 62368-1			
Clause	Requirement + Test	Result - Remark	Verdict

4.1.2	TABLE: List of critical components					P
Object / part No.	Manufacturer/ trademark	Type / model	Technical data	Standard	Mark(s) of conformity ¹⁾	
Enclosure	Mix Telematics	Drawing No.: MD00068-IB MD00069-ID MD00070-IA MD00071-1C MD00089-IB	Min. thickness: 1.0mm	IEC 62368-1:2014	Assessed in application	
Enclosure material	Covestro Deutschland AG [PC Resins]	Makrolon 2805	V-2 @ 0.75mm HB @	CCN: QMFZ2	UL (E41613)	
Rating label	Mix Telematics	Drawing: SLP0032A	Consisting of the below:	IEC 62368-1:2014	Assessed in application	
Material	Flexcon	THERMLfilm SELECT 21940	Material: THERMLfilm PM 200 W & TC-390 Adhesive: L-344			
Marking Method	Ade Labelling & Barcoding	B325	Ink: Silicone base			
Coin cell	Panasonic	CR2032/BR	3.0V, 225mAh Max. abnormal charge current: 10mA Max. discharge current: 3mA -30 to 60°C	IEC 60086-4:2014 CCN: BBCV2	DEKRA CB Cert: NL-59040 UL (MH12210)	
	Interchangeable	CR2032/BR	3.0V, 225mAh Min. abnormal charge current: 10mA Min. discharge current: 3mA Min. -30 to 60°C	IEC 60086-4:2014 CCN: BBCV2	Third party approval ¹⁾	
PCB	Interchangeable	Interchangeable	Min. V-1, 105°C	UL 796	Third party approval ¹⁾	

Supplementary information:

¹⁾ Provided evidence ensures the agreed level of compliance. See OD-CB2039.

IEC 62368-1			
Clause	Requirement + Test	Result - Remark	Verdict
4.8.4, 4.8.5	TABLE: Lithium coin/button cell batteries mechanical tests		P
(The following mechanical tests are conducted in the sequence noted.)			
4.8.4.2	TABLE: Stress Relief test		—
Part	Material	Oven Temperature (°C)	Comments
BT HOS DID enclosure	Covestro Deutschland AG [PC Resins] Makrolon 2805	70	No damage or deformation
4.8.4.3	TABLE: Battery replacement test		—
Battery part no.:	CR2032/BR		—
Battery Installation/withdrawal	Battery Installation/Removal Cycle		Comments
The battery compartment was held together with 2.9mm diameter screws	1		No damage
	2		No damage
	3		No damage
	4		No damage
	5		No damage
	6		No damage
	8		No damage
	9		No damage
	10		No damage
4.8.4.4	TABLE: Drop test		—
Impact Area	Drop Distance	Drop No.	Observations
Top of battery enclosure	1000mm	10	No damage
4.8.4.5	TABLE: Impact		—
Impacts per surface	Surface tested	Impact energy (J)	Comments
Three	Top of battery enclosure	2	No damage
4.8.4.6	TABLE: Crush test		—
Test position	Surface tested	Crushing Force (N)	Duration force applied (s)
Horizontal	Top of battery enclosure	330	10
Supplementary information:			

IEC 62368-1			
Clause	Requirement + Test	Result - Remark	Verdict

4.8.5	TABLE: Lithium coin/button cell batteries mechanical test result			P
Test position	Surface tested	Force (N)	Duration force applied (s)	
Horizontal	Top of battery enclosure	30	10	
Supplementary information:				

5.2	Table: Classification of electrical energy sources						P
5.2.2.2 – Steady State Voltage and Current conditions							
No.	Supply Voltage	Location (e.g. circuit designation)	Test conditions	Parameters			ES Class
				U (Vrms or Vpk)	I (Apk or Arms)	Hz	
1	-	BT HOS DID coin cell	Normal	3.0VDC	-	-	ES1
			Abnormal	-	-	-	
			Single fault – SC/OC	-	-	-	
5.2.2.3 - Capacitance Limits							
No.	Supply Voltage	Location (e.g. circuit designation)	Test conditions	Parameters		ES Class	
				Capacitance, nF	Upk (V)		
-	-	-	Normal	-	-	-	
			Abnormal	-	-		
			Single fault – SC/OC	-	-		
5.2.2.4 - Single Pulses							
No.	Supply Voltage	Location (e.g. circuit designation)	Test conditions	Parameters			ES Class
				Duration (ms)	Upk (V)	Ipk (mA)	
-	-	-	Normal	-	-	-	-
			Abnormal	-	-	-	
			Single fault – SC/OC	-	-	-	

IEC 62368-1			
Clause	Requirement + Test	Result - Remark	Verdict

5.2.2.5 - Repetitive Pulses

No.	Supply Voltage	Location (e.g. circuit designation)	Test conditions	Parameters			ES Class
				Off time (ms)	Upk (V)	l _{pk} (mA)	
-	-	-	Normal	-	-	-	-
			Abnormal	-	-	-	
			Single fault – SC/OC	-	-	-	

Test Conditions:

Normal –

Abnormal -

Supplementary information: SC=Short Circuit, OC=Short Circuit

IEC 62368-1			
Clause	Requirement + Test	Result - Remark	Verdict

5.4.1.4, 6.3.2, 9.0, B.2.6	TABLE: Temperature measurements – BT HOS DID					P	
	Supply voltage (V)	- 3)	- 3)	- 4)	- 4)	—	
	Ambient T _{min} (°C)	22.0	22.4	23.6	21.9	—	
	Ambient T _{max} (°C)	23.7	24.4	24.3	25.0	—	
	T _{ma} (°C)	65.0	65.0	65.0	65.0	—	
Maximum measured temperature T of part/at:		T (°C)				Allowed T _{max} (°C)	
BT HOS DID - U1 /U2 PCB adj		62.8	61.3	62.1	61.0	105	
BT HOS DID - Coin cell BT1 ambient		62.9	61.6	61.9	61.0	105	
BT HOS DID - Enclosure front touch ²⁾		28.0	27.0	27.3	26.0	48	
BT HOS DID - Button touch ²⁾		28.3	27.2	27.2	25.9	48	
Supplementary information:							
Temperature T of winding:	t ₁ (°C)	R ₁ (Ω)	t ₂ (°C)	R ₂ (Ω)	T (°C)	Allowed T _{max} (°C)	Insulation class
-	-	-	-	-	-	-	-
Supplementary information:							
Note 1: T _{ma} should be considered as directed by applicable requirement							
Note 2: T _{ma} is not included in assessment of Touch Temperatures (Clause 9), touch temperatures have been adjusted for an ambient of 25°C							
Note 3: Horizontal orientation							
Note 4: Vertical orientation							

IEC 62368-1			
Clause	Requirement + Test	Result - Remark	Verdict

5.4.1.10.2	TABLE: Vicat softening temperature of thermoplastics		N/A
Penetration (mm)..... :			—
Object/ Part No./Material	Manufacturer / trademark	T softening (°C)	
-	-	-	
Supplementary information:			

5.4.1.10.3	TABLE: Ball pressure test of thermoplastics			N/A
Allowed impression diameter (mm)	≤ 2 mm			—
Object/Part No./Material	Manufacturer/trademark	Test temperature (°C)	Impression diameter (mm)	
-	-	-	-	
Supplementary information:				

5.4.2.2, 5.4.2.4 and 5.4.3	TABLE: Minimum Clearances/Creepage distance						N/A
Clearance (cl) and creepage distance (cr) at/of/between:	Up (V)	U r.m.s. (V)	Frequency (kHz) ¹	Required cl (mm)	cl (mm) ²	Required ³ cr (mm)	cr (mm)
-	-	-	-	-	-	-	-
Supplementary information:							
Note 1: Only for frequency above 30 kHz							
Note 2: See table 5.4.2.4 if this is based on electric strength test							
Note 3: Provide Material Group							

IEC 62368-1			
Clause	Requirement + Test	Result - Remark	Verdict

5.4.2.3	TABLE: Minimum Clearances distances using required withstand voltage			N/A
	Overvoltage Category (OV):			-
	Pollution Degree:			-
Clearance distanced between:		Required withstand voltage	Required cl (mm)	Measured cl (mm)
-		-	-	-
Supplementary information:				

5.4.2.4	TABLE: Clearances based on electric strength test			N/A
Test voltage applied between:		Required cl (mm)	Test voltage (kV) peak/ r.m.s. / d.c.	Breakdown Yes / No
-		-	-	-
Supplementary information:				

5.4.4.2, 5.4.4.5 c) 5.4.4.9	TABLE: Distance through insulation measurements					N/A
Distance through insulation di at/of:		Peak voltage (V)	Frequency (kHz)	Material	Required DTI (mm)	DTI (mm)
-		-	-	-	-	-
Supplementary information:						

IEC 62368-1			
Clause	Requirement + Test	Result - Remark	Verdict

5.4.9	TABLE: Electric strength tests			N/A
Test voltage applied between:	Voltage shape (AC, DC)	Test voltage (V)	Breakdown Yes / No	
Basic/supplementary:				
-	-	-	-	
Reinforced:				
-	-	-	-	
Routine Tests:				
-	-	-	-	
Supplementary information:				

5.5.2.2	TABLE: Stored discharge on capacitors					N/A
Supply Voltage (V), Hz	Test Location	Operating Condition (N, S)	Switch position On or off	Measured Voltage (after 2 seconds)	ES Classification	
-	-	-	-	-	-	
Supplementary information:						
<p>X-capacitors installed for testing are:</p> <p><input type="checkbox"/> bleeding resistor rating:</p> <p><input type="checkbox"/> ICX:</p> <p>Notes:</p> <p>A. Test Location: Phase to Neutral; Phase to Phase; Phase to Earth; and/or Neutral to Earth</p> <p>B. Operating condition abbreviations: N – Normal operating condition (e.g., normal operation, or open fuse); S –Single fault condition</p>						

IEC 62368-1			
Clause	Requirement + Test	Result - Remark	Verdict

5.6.6.2	TABLE: Resistance of protective conductors and terminations				N/A
Accessible part	Test current (A)	Duration (min)	Voltage drop (V)	Resistance (Ω)	
-	-	-	-	-	
Supplementary information:					

5.7.2.2, 5.7.4	TABLE: Earthed accessible conductive part		N/A
Supply voltage	-	—	
Location	Test conditions specified in 6.1 of IEC 60990 or Fault Condition No in IEC 60990 clause 6.2.2.1 through 6.2.2.8, except for 6.2.2.7		Touch current (mA)
-	1		-
	2*		-
	3		-
	4		-
	5		-
	6		-
	8		-
Supplementary Information:			
Notes: [1] Supply voltage is the anticipated maximum Touch Voltage [2] Earthed neutral conductor [Voltage differences less than 1% or more] [3] Specify method used for measurement as described in IEC 60990 sub-clause 4.3 [4] IEC60990, sub-clause 6.2.2.7, Fault 7 not applicable. [5] (*) IEC60990, sub-clause 6.2.2.2 is not applicable if switch or disconnect device (e.g., appliance coupler) provided.			

IEC 62368-1			
Clause	Requirement + Test	Result - Remark	Verdict

6.2.2	Table: Electrical power sources (PS) measurements for classification					P
Source	Description	Measurement	Max Power after 3 s	Max Power after 5 s*)	PS Classification	
A	BT HOS DID coin cell	Power (W) :	0.36	-	PS1	
		V _A (V) :	1.0	-		
		I _A (A) :	0.36	-		
Supplementary Information:						
*) Measurement taken only when limits at 3 seconds exceed PS1 limits						

6.2.3.1	Table: Determination of Potential Ignition Sources (Arcing PIS)				P
Location	Open circuit voltage After 3 s (V _p)	Measured r.m.s current (I _{rms})	Calculated value (V _p x I _{rms})	Arcing PIS? Yes / No	
BT HOS DID coin cell	1.77	-	-	No	
Supplementary information:					
An Arcing PIS requires a minimum of 50 V (peak) a.c. or d.c. An Arcing PIS is established when the product of the open circuit voltage (V _p) and normal operating condition rms current (I _{rms}) is greater than 15.					

6.2.3.2	Table: Determination of Potential Ignition Sources (Resistive PIS)					P
Circuit Location (x-y)	Operating Condition (Normal / Describe Single Fault)	Measured wattage or VA During first 30 s (W / VA)	Measured wattage or VA After 30 s (W / VA)	Protective Circuit, Regulator, or PTC Operated? Yes / No (Comment)	Resistive PIS? Yes/No	
BT HOS DID coin cell	S/C C2	0.36	-	No	No	
Supplementary Information:						
A combination of voltmeter, VA and ammeter IA may be used instead of a wattmeter.						
If a separate voltmeter and ammeter are used, the product of (VA x IA) is used to determine Resistive PIS classification.						
A Resistive PIS: (a) dissipates more than 15 W, measured after 30 s of normal operation, <u>or</u> (b) under single fault conditions has either a power exceeding 100 W measured immediately after the introduction of the fault if electronic circuits, regulators or PTC devices are used, or has an available power exceeding 15 W measured 30 s after introduction of the fault.						

IEC 62368-1			
Clause	Requirement + Test	Result - Remark	Verdict

8.5.5	TABLE: High Pressure Lamp		N/A
Description	Values	Energy Source Classification	
Lamp type	-	—	
Manufacturer	-	—	
Cat no.	-	—	
Pressure (cold) (MPa).....	-	MS_	
Pressure (operating) (MPa)	-	MS_	
Operating time (minutes)	-	—	
Explosion method	-	—	
Max particle length escaping enclosure (mm) .:	-	MS_	
Max particle length beyond 1 m (mm).....:	-	MS_	
Overall result	-		
Supplementary information:			

IEC 62368-1			
Clause	Requirement + Test	Result - Remark	Verdict

B.2.5		TABLE: Input test						N/A
U (V)	Hz	I (A)	I rated (A)	P (W)	P rated (W)	Fuse No	I fuse (A)	Condition/status
-	-	-	-	-	-	-	-	-
Supplementary information:								
Equipment may be have rated current or rated power or both. Both should be measured								

B.3		TABLE: Abnormal operating condition tests						P
Ambient temperature (°C)							—	
Power source for EUT: Manufacturer, model/type, output rating .:						Coin cell	—	
Component No.	Abnormal Condition	Supply voltage, (V)	Test time (m:s)	Fuse no.	Fuse current, (A)	T-couple	Temp. (°C)	Observation
BT1	Reverse polarity	-	26:54	-	-	Q1	27.7	No adverse temperature, no hazard noted.
Supplementary information:								
Test table is provided to record abnormal and fault conditions for all applicable energy sources including Thermal burn injury. Column "Abnormal/Fault." Specify if test condition by indicating "Abnormal" then the condition for a Clause B.3 test or "Single Fault" then the condition for Clause B.4.								

IEC 62368-1			
Clause	Requirement + Test	Result - Remark	Verdict

B.4		TABLE: Fault condition tests						P
Ambient temperature (°C)		23.6						—
Power source for EUT: Manufacturer, model/type, output rating ..		ITech, IT7624, 1.5kVA						—
Component No.	Fault Condition	Supply voltage, (V)	Test time (m:s)	Fuse no.	Fuse current, (A)	T-couple	Temp. (°C)	Observation
C2	S/C	-	05:43	-	-	BT1	27.0	Battery discharged at 0.35A, dropping to 0.04A after approx. 20 seconds. No adverse temperatures and no hazard noted
Supplementary information:								

Annex M.3		TABLE: Batteries						P	
The tests of Annex M are applicable only when appropriate battery data is not available								P	
Is it possible to install the battery in a reverse polarity position?		Yes, no hazard						P	
	Non-rechargeable batteries			Rechargeable batteries					
	Discharging		Un-intentional charging	Charging		Discharging		Reversed charging	
	Meas. current	Manuf. Specs.		Meas. current	Manuf. Specs.	Meas. current	Manuf. Specs.	Meas. current	Manuf. Specs.
Max. current during normal condition	-*	3mA	Battery is the only power source	-	-	-	-	-	-
Max. current during fault condition	-*	3mA	Battery is the only power source	-	-	-	-	-	-
Test results:									
- Chemical leaks								P	
- Explosion of the battery								P	
- Emission of flame or expulsion of molten metal								P	
- Electric strength tests of equipment after completion of tests								P	
Supplementary information:									
*Battery certified & approved to 60086-4, tested under short circuit conditions									

IEC 62368-1			
Clause	Requirement + Test	Result - Remark	Verdict

Annex M.4		Table: Additional safeguards for equipment containing secondary lithium batteries			N/A
Battery/Cell No.	Test conditions	Measurements			Observation
		U	I (A)	Temp (C)	
-	Normal	-	-	-	-
	Abnormal	-	-	-	-
	Single fault –SC/OC	-	-	-	-
Supplementary Information:					
Battery identification	Charging at T_{lowest} (°C)	Observation	Charging at $T_{highest}$ (°C)	Observation	
-	-	-	-	-	-
Supplementary Information:					

Annex Q.1		TABLE: Circuits intended for interconnection with building wiring (LPS)			N/A	
Note: Measured UOC (V) with all load circuits disconnected:						
Output Circuit	Components	U _{oc} (V)	I _{sc} (A)		S (VA)	
			Meas.	Limit	Meas.	Limit
-	-	-	-	-	-	-
Supplementary Information:						
SC=Short circuit, OC=Open circuit						

T.2, T.3, T.4, T.5		TABLE: Steady force test				P
Part/Location	Material	Thickness (mm)	Force (N)	Test Duration (sec)	Observation	
Enclosure	Covestro, Makrolon 2805	1.0	250	5	No damage or deformation noted	
Supplementary information:						

IEC 62368-1			
Clause	Requirement + Test	Result - Remark	Verdict

T.6, T.9	TABLE: Impact tests				N/A
Part/Location	Material	Thickness (mm)	Vertical distance (mm)	Observation	
-	-	-	-	-	
Supplementary information:					

T.7	TABLE: Drop tests				P
Part/Location	Material	Thickness (mm)	Drop Height (mm)	Observation	
Enclosure	Covestro, Makrolon 2805	1.0	1000	No damage or deformation noted	
Supplementary information:					

T.8	TABLE: Stress relief test					P
Part/Location	Material	Thickness (mm)	Oven Temperature (°C)	Duration (h)	Observation	
Enclosure	Covestro, Makrolon 2805	1.0	70	7	No damage or deformation noted	
Supplementary information:						

IEC62368_1D - ATTACHMENT			
Clause	Requirement + Test	Result - Remark	Verdict
ATTACHMENT TO TEST REPORT IEC 62368-1 EUROPEAN GROUP DIFFERENCES AND NATIONAL DIFFERENCES (Audio/video, information and communication technology equipment Part 1: Safety requirements)			
Differences according to: EN 62368-1:2014			
Attachment Form No.: EU_GD_IEC62368_1B			
Attachment Originator: Intertek Semko AB			
Master Attachment: Date 2021-02-04			
Copyright © 2021 IEC System of Conformity Assessment Schemes for Electrotechnical Equipment and Components (IECEE)			

	GENELEC COMMON MODIFICATIONS (EN)		
1	NOTE Z1	Not assessed for RoHS	N/A
4.Z1	Protective devices included as integral parts of the equipment or as parts of the building installation:	Not AC mains	N/A
	a) Included as parts of the equipment		N/A
	b) For components in series with the mains; by devices in the building installation		N/A
	c) For pluggable type B or permanently connected; by devices in the building installation		N/A
5.4.2.3.2.4	Interconnection with external circuit		N/A
10.2.1	Additional requirements in 10.5.1		N/A
10.5.1	RS1 compliance measurement conditions		N/A
10.6.2.1	EN 71-1:2011, 4.20 and methods and distances		N/A
10.Z1	Non-ionizing radiation from radio frequencies in the range 0 to 300 GHz		N/A
G.7.1	NOTE Z1		N/A

ZB	ANNEX ZB, SPECIAL NATIONAL CONDITIONS (EN)		
4.1.15	Denmark, Finland, Norway and Sweden: Class I pluggable equipment type A marking		N/A
4.7.3	United Kingdom: Torque test socket-outlet BS 1363, and the plug part BS 1363.		N/A
5.2.2.2	Denmark: Warning for high touchcurrent		N/A
5.4.11.1 and Annex G	Finland and Sweden: Separation of the telecommunication network from earth		N/A

IEC62368_1D - ATTACHMENT			
Clause	Requirement + Test	Result - Remark	Verdict
5.5.2.1	Norway: Capacitors rated for the applicable line-to-line voltage (230 V).		N/A
5.5.6	Finland, Norway and Sweden: Resistors used as basic safeguard or bridging basic insulation comply with G.10.1 and G.10.2.		N/A
5.6.1	Denmark: Protection for pluggable equipment type A; integral part of the equipment		N/A
5.6.4.2.1	Ireland and United Kingdom: The protective current rating is taken to be 13 A		N/A
5.6.5.1	Ireland and United Kingdom: Conductor sizes of flexible cords to be accepted by terminals for equipment rated 10 A to 13 A		N/A
5.7.5	Denmark: The installation instruction affixed to the equipment if high protective conductor current		N/A
5.7.6.1	Norway and Sweden: Television distribution system isolation text in user manual		N/A
5.7.6.2	Denmark: Warning for high touch current		N/A
B.3.1 and B.4	Ireland and United Kingdom: Tests conducted using an external miniature circuit breaker or protective devices included as an integral part of the direct plug-in equipment		N/A
G.4.2	Denmark: Appliances rated ≤ 13 A provided with a plug according to DS 60884-2-D1:2011.		N/A
	Class I equipment provided with socket-outlets provided with a plug in accordance with standard sheet DK 2-1a or DK 2-5a.		N/A
	If a single-phase equipment having rated >13 A or poly-phase equipment provided with a supply cord with a plug, plug in accordance with the standard sheets DK 6-1a in DS 60884-2-D1 or EN 60309-2.		N/A
	Mains socket outlets intended for providing power to Class II apparatus rated 2,5 A in accordance with DS 60884-2-D1:2011 standard sheet DKA 1-4a.		N/A
	Other current rating socket outlets in compliance with Standard Sheet DKA 1-3a or DKA 1-1c.		N/A
	Mains socket-outlets with earth in compliance with DS 60884-2-D1:2011 Standard Sheet DK 1-3a, DK 1-1c, DK1-1d, DK 1-5a or DK 1-7a		N/A
G.4.2	United Kingdom: The plug part of direct plug-in equipment assessed to BS 1363		N/A

IEC62368_1D - ATTACHMENT			
Clause	Requirement + Test	Result - Remark	Verdict
G.7.1	United Kingdom: Equipment fitted with a 'standard plug' in accordance with the Plugs and Sockets etc (Safety) Regulations 1994, Statutory Instrument 1994 No. 1768		N/A
G.7.1	Ireland: Apparatus provided with a plug in accordance with Statutory Instrument 525: 1997, "13 A Plugs and Conversion Adapters for Domestic Use		N/A
G.7.2	Ireland and United Kingdom: A power supply cord for equipment which is rated over 10 A and up to and including 13 A.		N/A

ZC	ANNEX ZC, NATIONAL DEVIATIONS (EN)		N/A
10.5.2	Germany: Cathode ray tube intended for the display of visual images, authorization or application of type approval and marking.		N/A
F.1	Italy: The power consumption in Watts (W) indicated on TV receiver and in instruction for use		N/A
	TV receivers provided with an instruction for use, schematic diagrams and adjustments procedure in Italian language.		N/A
	Marking for controls and terminals in Italian language.		N/A
	Conformity declaration according to the above requirements in the instruction manual		N/A
	First importers of TV receivers manufactured outside EEC previous conformity certification to the Italian Post Ministry and Certification number on the backcover.		N/A

IEC62368_1D ATTACHMENT			
Clause	Requirement + Test	Result - Remark	Verdict
ATTACHMENT TO TEST REPORT IEC 62368-1 U.S.A. AND CANADA NATIONAL DIFFERENCES (Audio/video, information and communication technology equipment – Part 1: Safety requirements)			
Differences according to.....: CSA/UL 62368-1:2014			
TRF template used: IECCE OD-2020-F3, Ed. 1.1			
Attachment Form No.....: US_CA_ND_IEC62368_1D			
Attachment Originator UL(US)			
Master Attachment Dated 2021-02-04			
Copyright © 2021 IEC System for Conformity Testing and Certification of Electrical Equipment (IECEE), Geneva, Switzerland. All rights reserved.			

IEC 62368-1 - US and Canada National Differences Special National Conditions based on Regulations and Other National Differences			
1.1	All equipment is to be designed to allow installation according to the National Electrical Code (NEC), ANSI/NFPA 70, the Canadian Electrical Code (CEC), Part I, CAN/CSA C22.1, and when applicable, the National Electrical Safety Code, IEEE C2. Also, for such equipment marked or otherwise identified, installation is allowed per the Standard for the Protection of Information Technology Equipment, ANSI/NFPA 75.		P
1.4	Additional requirements apply to some forms of power distribution equipment, including sub-assemblies.		N/A
4.1.17	For lengths exceeding 3.05 m, external interconnecting flexible cord and cable assemblies are required to be a suitable cable type (e.g., DP, CL2) specified in the NEC.		N/A
	For lengths 3.05 m or less, external interconnecting flexible cord and cable assemblies that are not types specified in the NEC generally are required to have special construction features and identification markings.		N/A
4.8	Lithium coin / button cell batteries have modified special construction and performance requirements.	Captive screws provided	P

IEC62368_1D ATTACHMENT			
Clause	Requirement + Test	Result - Remark	Verdict
5.6.3	Protective earthing conductors comply with the minimum conductor sizes in Table G.5, except as required by Table G.7ADV.1 for cord connected equipment, or Annex DVH for permanently connected equipment		N/A
5.7.7	Equipment intended to receive telecommunication ringing signals complies with a special touch current measurement tests.		N/A
6.5.1	PS3 wiring outside a fire enclosure complies with single fault testing in B.4, or be current limited per one of the permitted methods.		P
Annex F (F.3.3.8)	Output terminals provided for supply of other equipment, except mains, supply are marked with a maximum rating or references to which equipment it is permitted to be connected.		N/A
Annex G (G.7.1)	Permanent connection of equipment to the mains supply by a power supply cord is not permitted, except for certain equipment, such as ATMs.		N/A
Annex G (G.7.3)	Power supply cords are required to have attachment plugs rated not less than 125 percent of the rated current of the equipment.		N/A
	Flexible power supply cords are required to be compatible with Article 400 of the NEC, and Tables 11 and 12 of the CEC.		N/A
Annex G (G.7.5)	Minimum cord length is required to be 1.5 m, with certain constructions such as external power supplies allowed to consider both input and output cord lengths into the requirement. Power supply cords are required to be no longer than 4.5 m in length if used in ITE Rooms.		N/A
Annex H.2	Continuous ringing signals under normal operating conditions up to 16 mA only are permitted if the equipment is subjected to special installation and performance restrictions.		N/A
Annex H.4	For circuits with other than ringing signals and with voltages exceeding $42.4 V_{peak}$ or 60 V d.c., the maximum acceptable current through a 2000 ohm resistor (or greater) connected across the voltage source with other loads disconnected is 7.1 mA peak or 30 mA d.c. under normal operating conditions.		N/A
Annex M	Battery packs for stationary applications comply with special component requirements.		N/A

IEC62368_1D ATTACHMENT			
Clause	Requirement + Test	Result - Remark	Verdict
Annex DVA (1)	Equipment intended for use in spaces used for environmental air are subjected to special flammability requirements for heat and visible smoke release.		N/A
	For ITE room applications, automated information storage systems with combustible media greater than 0.76 m ³ (27 cu ft) have a provision for connection of either automatic sprinklers or a gaseous agent extinguishing system with an extended discharge.		N/A
	Consumer products designed or intended primarily for children 12 years of age or younger are subject to additional requirements in accordance with U.S. & Canadian Regulations.		N/A
	Baby monitors additionally comply with ASTM F2951, Consumer Safety Specification for Baby Monitors.		N/A
Annex DVA (5.6.3)	For Pluggable Equipment Type A, the protection in the installation is assumed to be 20A.		N/A
Annex DVA (6.3)	The maximum quantity of flammable liquid stored in equipment complies with NFPA 30.		N/A
Annex DVA (6.4.8)	For ITE room applications, enclosures with combustible material measuring greater than 0.9 m ² (10 sq ft) or a single dimension greater than 1.8 m (6 ft) have a flame spread rating of 50 or less. For equipment with the same dimensions for other applications, an external surface that is not a fire enclosure requires a min. flammability classification of V-1.		N/A
Annex DVA (10.3.1)	Equipment with lasers meets the U.S. Code of Federal Regulations 21 CFR 1040 (and the Canadian Radiation Emitting Devices Act, REDR C1370).		N/A
Annex DVA (10.5.1)	Equipment that produces ionizing radiation complies with the U.S. Code of Federal Regulations, 21 CFR 1020 (and the Canadian Radiation Emitting Devices Act, REDR C1370).		N/A
Annex DVA (F.3.3.3)	Equipment for use on a.c. mains supply systems with a neutral and more than one phase conductor (e.g. 120/240 V, 3-wire) require a special marking format for electrical ratings. Additional considerations apply for voltage ratings that exceed the attachment cap rating or are lower than the "Normal Operating Condition" in Table 2 of CAN/CSA C22.2 No. 235."		N/A

IEC62368_1D ATTACHMENT			
Clause	Requirement + Test	Result - Remark	Verdict
Annex DVA (F.3.3.5)	Equipment identified for ITE (computer) room installation is marked with the rated current		N/A
Annex DVA (G.1)	Vertically-mounted disconnect switches and circuit breakers have the "on" position indicated by the handle in the up position		N/A
Annex DVA (G.3.4)	Suitable NEC/CEC branch circuit protection rated at the maximum circuit rating is required for all standard supply outlets and receptacles (such as supplied in power distribution units) if the supply branch circuit protection is not suitable.		N/A
Annex DVA (G.4.2)	Equipment with isolated ground (earthing) receptacles complies with NEC 250.146(D) and CEC 10-112 and 10-906(8).		N/A
Annex DVA (G.4.3)	Where a fuse is used to provide Class 2 or Class 3 current limiting, it is not operator-accessible unless it is non-interchangeable.		N/A
Annex DVA (G.5.3)	Power distribution transformers distributing power at 100 volts or more, and rated 10 kVA or more, require special transformer overcurrent protection.		N/A
Annex DVA (G.5.4)	Motor control devices are required for cord-connected equipment with a mains-connected motor if the equipment is rated more than 12 A, or if the equipment has a nominal voltage rating greater than 120 V, or if the motor is rated more than 1/3 hp (locked rotor current over 43 A).		N/A
Annex DVA (Annex M)	For ITE room applications, equipment with battery systems capable of supplying 750 VA for five minutes have a battery disconnect means that may be connected to the ITE room remote power-off circuit.		N/A
Annex DVA (Q)	Wiring terminals intended to supply Class 2 outputs according to the NEC or CEC Part 1 are marked with the voltage rating and "Class 2" or equivalent; marking is located adjacent to the terminals and visible during wiring.		N/A
Annex DVB (1)	Additional requirements apply for equipment used for entertainment purposes intended for installation in general patient care areas of health care facilities.		N/A
Annex DVC (1)	Additional requirements apply for equipment intended for mounting under kitchen cabinets.		N/A

IEC62368_1D ATTACHMENT			
Clause	Requirement + Test	Result - Remark	Verdict
Annex DVE (4.1.1)	Some equipment, components, sub-assemblies and materials associated with the risk of fire, electric shock, or personal injury have component or material ratings in accordance with the applicable national (U.S. and Canadian) component or material requirements. Components required to comply include: appliance couplers, attachment plugs, battery back-up systems, battery packs, circuit breakers, communication circuit accessories, connectors (used for current interruption of non-LPS circuits), power supply cords, direct plug-in equipment, electrochemical capacitor modules (energy storage modules with ultra-capacitors), enclosures (outdoor), flexible cords and cables, fuses (branch circuit), ground-fault current interrupters, interconnecting cables, data storage equipment, printed wiring, protectors for communications circuits, receptacles, surge protective devices, vehicle battery adapters, wire connectors, and wire and cables.		N/A
Annex DVH	Equipment for permanent connection to the mains supply is subjected to additional requirements.		N/A
Annex DVH (DVH.1)	Wiring methods (terminals, leads, etc.) used for the connection of the equipment to the mains are in accordance with the NEC/CEC.		N/A
Annex DVH (DVH.3.2)	Terminals for permanent wiring, including protective earthing terminals, are suitable for U.S./Canadian wire gauge sizes, rated 125 percent of the equipment rating, and are specially marked when specified.		N/A
Annex DVH (DVH.3.2)	Wire binding screws are not permitted to attach conductors larger than 10 AWG (5.3 mm ²).		N/A
Annex DVH (DVH.4)	Permanently connected equipment is required to have a suitable wiring compartment and wire bending space.		N/A
Annex DVH (DVH 5.5)	Equipment connected to a centralized d.c. power system, and having one pole of the DC mains input terminal connected to the main protective earthing terminal in the equipment, complies with special earthing, wiring, marking and installation instruction requirements.		N/A
Annex DVI (6.7)	Equipment intended for connection to telecommunication network outside plant cable is required to be protected against overvoltage from power line crosses.		N/A

IEC62368_1D ATTACHMENT			
Clause	Requirement + Test	Result - Remark	Verdict
Annex DVJ (10.6.1)	Equipment connected to a telecommunication and cable distribution networks and supplied with an earphone intended to be held against, or in the ear is required to comply with special acoustic pressure requirements.		N/A

IEC 62368_1D ATTACHMENT			
Clause	Requirement + Test	Result - Remark	Verdict
ATTACHMENT TO TEST REPORT			
IEC 62368-1 (AUSTRALIA / NEW ZEALAND) NATIONAL DIFFERENCES (Audio/video, information and communication technology equipment)			
Differences according to : AS/NZS 62368.1:2018			
TRF template used:: IECEE OD-2020-F3, Ed. 1.1			
Attachment Form No. : AU_NZ_ND_IEC62368_1D			
Attachment Originator : JAS-ANZ			
Master Attachment..... : 2022-05-01			
Copyright © 2020 IEC System for Conformity Testing and Certification of Electrical Equipment (IECEE), Geneva, Switzerland. All rights reserved.			
	National Differences		P
Appendix ZZ	Variations to IEC 62368-1:2014 (ED. 2.0) for Australia and New Zealand		N/A
ZZ1 Scope	This Appendix lists the normative variations to IEC 62368-1:2014 (ED. 2.0)		N/A
ZZ2 Variations	The following modifications are required for Australian/New Zealand conditions:		N/A
2	<p>Add the following to the list of normative references:</p> <p>The following normative documents are referenced in Appendix ZZ:</p> <ul style="list-style-type: none"> -AS/NZS 3112, <i>Approval and test specification—Plugs and socket-outlets</i> -AS/NZS 3123, <i>Approval and test specification—Plugs, socket-outlets and couplers for general industrial application</i> -AS/NZS 3191, <i>Electric flexible cords</i> -AS/NZS 60065, <i>Audio, video and similar electronic apparatus—Safety requirements (IEC 60065:2015 (ED.8.0) MOD)</i> -AS/NZS 60320.1, <i>Appliance couplers for household and similar general purposes, Part 1: General requirements (IEC 60320-1, Ed.2.1 (2007) MOD)</i> -AS/NZS 60320.2.2, <i>Appliance couplers for household and similar general purposes Part 2.2: Interconnection couplers for household and similar equipment (IEC 60320-2-2, Ed.2.0 (1998) MOD)</i> -AS/NZS 60695.2.11, <i>Fire hazard testing, Part 2.11: Glowing/hot wire based test methods—Glow-wire flammability test method for end-products</i> -AS/NZS 60695.11.5, <i>Fire hazard testing, Part 11.5: Test flames—Needle-flame test method—Apparatus, confirmatory test arrangement and guidance</i> -AS/NZS 60695.11.10, <i>Fire hazard testing, Part 11.10: Test flames—50 W</i> 		N/A

IEC 62368_1D ATTACHMENT			
Clause	Requirement + Test	Result - Remark	Verdict
	<p><i>horizontal and vertical flame test methods</i></p> <p>-AS/NZS 60884.1, <i>Plugs and socket-outlets for household and similar purposes, Part 1: General requirements</i></p> <p>-AS/NZS 60950.1:2015, <i>Information technology equipment—Safety, Part 1: General requirements (IEC 60950-1, Ed.2.2 (2013), MOD)</i></p> <p>IEC 61032:1997, <i>Protection of persons and equipment by enclosures—Probes for verification</i></p> <p>-AS/NZS 61558.1:2008 (including Amendment 2:2015), <i>Safety of Power Transformers, Power Supplies, Reactors and Similar Products, Part 1: General requirements and tests (IEC 61558-1 Ed 2.1, MOD)</i></p> <p>-AS/NZS 61558.2.16, <i>Safety of transformers, reactors, power supply units and similar products for voltages up to 1 100 V, Part 2.16: Particular requirements and tests for switch mode power supply units and transformers for switch mode power supply units.</i></p>		
4.1.1	<p>Application of requirements and acceptance of materials, components and subassemblies</p> <p>1 <i>Replace the text ‘IEC 60950-1’ with ‘AS/NZS 60950.1:2015’.</i></p> <p>2 <i>Replace the text ‘IEC 60065’ with ‘AS/NZS 60065’.</i></p>		N/A
4.7	Equipment for direct insertion into mains socket-outlets		N/A
4.7.2	<p>Requirements</p> <p><i>Delete the text of the second paragraph and replace with the following:</i></p> <p>Equipment with a plug portion, suitable for insertion into a 10 A 3-pin flat-pin socket-outlet complying with AS/NZS 3112 shall comply with the requirements in AS/NZS 3112 for equipment with integral pins for insertion into socket-outlets.</p>		N/A
4.7.3	<p>Compliance Criteria</p> <p><i>Delete the first paragraph and Note 1 and Note 2 and replace with the following:</i></p> <p><i>Compliance is checked by inspection and, if necessary, by the tests in AS/NZS 3112.</i></p>		N/A
4.8	<p><i>Delete existing clause title and replace with the following:</i></p> <p>4.8 Products containing coin/button cell batteries</p>		P

IEC 62368_1D ATTACHMENT					
Clause	Requirement + Test		Result - Remark	Verdict	
4.8.1	<p>General</p> <p>1 Second dashed point, <i>delete</i> the text and <i>replace</i> with the following: – include coin/button cell batteries with a diameter of 32 mm or less.</p> <p>2 After the second dashed point, <i>insert</i> the following Note: NOTE 1: Batteries are specified in IEC 60086-2.</p> <p>3 After the third dashed point, <i>renumber</i> the existing Note as 'NOTE 2'.</p> <p>4 Fifth dashed point, <i>delete</i> the word 'lithium'.</p>			P	
4.8.2	<p>Instructional Safeguard</p> <p>First line, <i>delete</i> the word 'lithium'.</p>			P	
4.8.3	<p>Construction</p> <p>First line, after the word 'Equipment' <i>insert</i> the words 'containing one or more coin/button batteries and'</p>			P	
4.8.5	<p>Compliance criteria</p> <p><i>Delete</i> the first paragraph and <i>replace</i> with the following: <i>Compliance is checked by applying a force of 30 N +/- 1 N for 10 s to the battery compartment door/cover by a rigid test finger according to test probe 11 of IEC 61032:1997 at the most unfavourable place and in the most unfavourable direction. The force shall be applied in one direction at a time.</i></p>			P	
5.4.10.2	Test methods			N/A	
5.4.10.2.1	<p>General</p> <p><i>Delete</i> the first paragraph and <i>replace</i> with the following: In Australia only, the separation is checked by the test of both Clause 5.4.10.2.2 and Clause 5.4.10.2.3. In New Zealand, the separation is checked by the test of either Clause 5.4.10.2.2 or Clause 5.4.10.2.3.</p>			N/A	
Table 29	<i>Replace</i> the table with the following:			N/A	
Parts		Impulse test		Steady state test	
		New Zealand	Australia	New Zealand	Australia
Parts indicated in Clause 5.4.10.1 a) ^a		2.5 kV 10/700 µs	7.0 kV for hand-held telephones and headsets, 2.5 kV for other equipment. 10/700 µs	1.5 kV	3 kV
Parts indicated in Clause 5.4.10.1 b) and c) ^b		1.5 kV 10/700 µs ^c		1.0 kV	1.5 kV
<p>^a Surge suppressors shall not be removed.</p> <p>^b Surge suppressors may be removed, provided that such devices pass the impulse test of Clause 5.4.10.2.2 when tested as components outside the equipment.</p> <p>^c During this test, it is allowed for a surge suppressor to operate and for a sparkover to occur in a GDT.</p>					

IEC 62368_1D ATTACHMENT			
Clause	Requirement + Test	Result - Remark	Verdict
5.4.10.2.2	After the first paragraph, <i>insert</i> new Notes 201 and 202 as follows: NOTE 201 For Australia, the 7 kV impulse simulates lightning surges on typical rural and semi-rural network lines. NOTE 202 For Australia, the value of 2.5 kV for Clause 5.4.10.1 a) was chosen to ensure the adequacy of the insulation concerned and does not necessarily simulate likely overvoltages.		N/A
5.4.10.2.3	After the first paragraph, <i>insert</i> new Notes 201 and 202 as follows: NOTE 201 For Australia, where there are capacitors across the insulation under test, it is recommended that d.c. test voltages are used. NOTE 202 The 3 kV and 1.5 kV values for Australia have been determined considering the low frequency induced voltages from the power supply distribution system.		N/A
6	Electrically-caused fire		P
6.1	General After the first paragraph, <i>insert</i> the following new paragraph: Alternatively, the requirements of Clauses 6.2 to 6.5.2 are considered to be fulfilled if the equipment complies with the requirements of Clause 6.202		P
6.6	After Clause 6.6, <i>add</i> the new Clauses 6.201 and 6.202 as follows: 6.201 External power supplies, docking stations and other similar devices and 6.202 Resistance to fire—Alternative tests (see special national conditions)		N/A
8.5.4	Special categories of equipment comprising moving parts		N/A
8.5.4.1	Large data storage equipment In the first dashed row and the second dashed rows <i>replace</i> 'IEC 60950-1:2005' with 'AS/NZS 60950.1:2015'.		N/A
8.6	Stability of equipment		N/A

IEC 62368_1D ATTACHMENT			
Clause	Requirement + Test	Result - Remark	Verdict
8.6.1 and Table 36	<p>Requirements</p> <p>1. Table 36, <i>insert</i> Footnote c at the end of the 'Glass slide' heading, and <i>add</i> a new Footnote c after the text of Footnote b in the last row of Table 36 as follows:</p> <p>^c The glass slide test is not applicable to floor standing equipment, even though the equipment may have controls or a display.</p> <p>2. Table 36, fifth row, <i>insert</i> ²⁰¹ at the end of 'No stability requirements'</p> <p>3. Table 36, ninth row, <i>insert</i> ²⁰¹ at the end of 'No stability requirements'</p> <p>4. Table 36, <i>add</i> the following new footnote: ²⁰¹ MS2 and MS3 television sets and display devices, designed only for fixing to a wall, ceiling or equipment rack, are not subjected to stability requirements only if the instructional safeguard of Clause 8.6.1.201 is provided. Otherwise, the glass slide requirements of Clause 8.6.4 and horizontal force requirements of Clause 8.6.5 apply.</p> <p>5. Second paragraph beneath Table 36, <i>delete</i> the words 'MS2 and MS3 television sets' and <i>replace</i> with 'MS2 and MS3 television sets and display devices'</p>		N/A
8.6.1	<p>After Clause 8.6.1 <i>add</i> the following new clauses: 8.6.1.201 Instructional safeguard for fixed-mount television sets (see special national conditions)</p>		N/A
Annex F Paragraph F.3.5.1	<p>Mains appliance outlet and socket-outlet markings <i>Replace</i> 'IEC 60320-2-2' with 'AS/NZS 60320.2.2'.</p>		N/A
Annex G Paragraph G.4.2	<p>Mains connectors</p> <p>1 In the second line <i>insert</i> 'or AS/NZS 3123' after 'IEC 60906-1'.</p> <p>2 In the second line <i>insert</i> 'or AS/NZS 60320 series' after 'IEC 60320 series'</p> <p>3 <i>Add</i> the following new paragraph: 10 A or 15 A 250 V flat pin plugs for the connection of equipment to mains-powered socket-outlets for household or similar general use shall comply with AS/NZS 3112 or AS/NZS 60884.1.</p>		N/A
Paragraph G.5.3.1	<p>Transformers, General</p> <p>1 In the third dashed point <i>replace</i> 'IEC 61558-1 and the relevant parts of IEC 61558-2' with 'AS/NZS 61558-1 and the relevant parts of AS/NZS 61558.2'</p> <p>2 In the fourth dashed point <i>replace</i> 'IEC 61558-2-16' with 'AS/NZS 61558.2.16'.</p>		N/A
Paragraph G.7.1	<p>Mains supply cords, General In the fourth dashed paragraph, <i>replace</i> 'IEC 60320-1' with 'AS/NZS 60320.1'</p>		N/A

IEC 62368_1D ATTACHMENT			
Clause	Requirement + Test	Result - Remark	Verdict
Table G.5	<p>Sizes of conductors</p> <p>1 In the second row, first column, <i>delete</i> '6' and <i>replace</i> with '7.5'</p> <p>2 In the second row, second column, <i>delete</i> '0,75' and <i>replace</i> with '0.75^b'</p> <p>3 <i>Delete</i> Note 1.</p> <p>4 <i>Replace</i> 'NOTE 2' with 'NOTE:'.</p> <p>5 <i>Delete</i> the text of 'Footnote b' and <i>replace</i> with the following:</p> <p>^b This nominal cross-sectional area is only allowed for Class II appliances if the length of the power supply cord, measured between the point where the cord, or cord guard, enters the appliance, and the entry to the plug does not exceed 2 m (0.5 mm² three-core supply flexible cords are not permitted; see AS/NZS 3191).</p> <p>6 In Footnote c <i>replace</i> 'IEC 60320-1' with 'AS/NZS 60320.1'</p> <p>7 In Footnote d <i>replace</i> 'IEC 60320-1' with 'AS/NZS 60320.1'</p>		N/A
Annex M Paragraph M.3.2	<p>Protection circuits for batteries provided within the equipment, Test method</p> <p>After the first dashed point <i>add</i> the following Note: NOTE 201: In cases where the voltage source is provided by power from an unassociated power source, consideration should be given to the effects of possible single fault conditions in the unassociated equipment. If the power source is unknown then it should be assumed that the maximum limit of SELV may be applied to the source input under assumed single fault conditions in the source when assessing the charging circuit in the equipment under test.</p>		N/A
			N/A
	Special national conditions (if any)		N/A

IEC 62368_1D ATTACHMENT			
Clause	Requirement + Test	Result - Remark	Verdict
6.201	<p>External power supplies, docking stations and other similar devices</p> <p>For external power supplies, docking stations and other similar devices, during and after abnormal operating conditions and during single fault conditions the output voltage—</p> <ul style="list-style-type: none"> – at all ES1 outlets or connectors shall not increase by more than 10% of its rated output voltage under normal operating condition; and – of a USB outlet or connector shall not increase by more than 3 V or 10% of its rated output voltage under normal operating conditions, whichever is higher. <p>For equipment with multiple rated output voltages, the requirements apply with the equipment configured for each rated output voltage in turn.</p> <p>NOTE: This is intended to reduce the possibility of battery fire or explosion in attached equipment or accessories when charging secondary lithium batteries.</p> <p><i>Compliance shall be checked by measurement, taking into account the abnormal operating conditions of Annex B.3 and the simulated single-fault conditions of Annex B.4</i></p>		N/A
6.202	Resistance to fire—Alternative tests		N/A
6.202.1	<p>General</p> <p>Parts of non-metallic material shall be resistant to ignition and spread of fire.</p> <p>This requirement does not apply to decorative trims, knobs and other parts unlikely to be ignited or to propagate flames from inside the equipment, or the following:</p> <p>a) Components that are contained in an enclosure having a flammability category of V-0 according to AS/NZS 60695.11.10 and having openings only for the connecting wires filling the openings completely, and for ventilation not exceeding 1 mm in width regardless of length.</p> <p>b) The following parts which would contribute negligible fuel to a fire:</p> <ul style="list-style-type: none"> – small mechanical parts, the mass of which does not exceed 4 g, such as mounting parts, gears, cams, belts and bearings; – small electrical components, such as capacitors with a volume not exceeding 1 750 mm³, integrated circuits, transistors and optocoupler packages, if these components are mounted on material of flammability category V-1, or better, according to AS/NZS 60695.11.10. <p>NOTE: In considering how to minimize propagation of fire and what 'small parts' are, account should be taken of the cumulative effect of small parts adjacent to each other for the possible effect of propagating the fire from one part to another.</p>		N/A

IEC 62368_1D ATTACHMENT									
Clause	Requirement + Test	Result - Remark	Verdict						
	<p><i>Compliance shall be checked by the tests of Clauses 6.202.2, 6.202.3 and 6.202.4.</i></p> <p>For the base material of printed boards, compliance shall be checked by the test of Clause 6.202.5.</p> <p>The tests shall be carried out on parts of non-metallic material which have been removed from the equipment. When the glow-wire test is carried out, the parts shall be placed in the same orientation as they would be in normal use.</p> <p>These tests are not carried out on internal wiring.</p>		N/A						
6.202.2	<p>Testing of non-metallic materials</p> <p>Parts of non-metallic material shall be subject to the glow-wire test of AS/NZS 60695.2.11 which shall be carried out at 550°C.</p> <p>Parts for which the glow-wire test cannot be carried out, such as those made of soft or foamy material, shall meet the requirements specified in ISO 9772 for category FH-3 material. The glow-wire test shall be not carried out on parts of material classified at least FH-3 according to ISO 9772 provided that the relevant part is not thinner than the sample tested.</p>		N/A						
6.202.3	<p>Testing of insulating materials</p> <p>Parts of insulating material supporting Potential Ignition Sources shall be subject to the glow-wire test of AS/NZS 60695.2.11 which shall be carried out at 750°C.</p> <p>The test shall be also carried out on other parts of insulating material which are within a distance of 3 mm of the connection.</p> <p>NOTE: Contacts in components such as switch contacts are considered to be connections</p>		N/A						
	<p>For parts which withstand the glow-wire test but produce a flame, other parts above the connection within the envelope of a vertical cylinder having a diameter of 20 mm and a height of 50 mm shall be subjected to the needle-flame test.</p> <p>However, parts shielded by a barrier which meets the needle-flame test need not be tested</p>		N/A						
	<p>The needle-flame test shall be made in accordance with AS/NZS 60695.11.5 with the following modifications:</p> <table border="1"> <tbody> <tr> <td>Clause of AS/NZS 60695.11.5</td> <td>Change</td> </tr> <tr> <td>9 Test procedure</td> <td></td> </tr> <tr> <td>9.2 Application of needle-flame</td> <td>Delete the first and second paragraphs and <i>replace</i> with the following:</td> </tr> </tbody> </table>	Clause of AS/NZS 60695.11.5	Change	9 Test procedure		9.2 Application of needle-flame	Delete the first and second paragraphs and <i>replace</i> with the following:		N/A
Clause of AS/NZS 60695.11.5	Change								
9 Test procedure									
9.2 Application of needle-flame	Delete the first and second paragraphs and <i>replace</i> with the following:								

IEC 62368_1D ATTACHMENT				
Clause	Requirement + Test		Result - Remark	Verdict
		<p>The specimen shall be arranged so that the flame can be applied to a vertical or horizontal edge as shown in the examples of Figure 1. If possible the flame shall be applied at least 10 mm from a corner.</p> <p>The duration of application of the test flame shall be 30 s \square 1 s.</p>		
	9.3 Number of test specimens	<p><i>Replace with the following:</i> The test shall be made on one specimen. If the specimen does not withstand the test, the test may be repeated on two further specimens, both of which shall withstand the test.</p>		
	11 Evaluation of test results	<p><i>Replace with the following:</i> The duration of burning (tb) shall not exceed 30 s. However, for printed circuit boards, it shall not exceed 15 s.</p>		
	<p>The needle-flame test shall not be carried out on parts of material classified as V-0 or V-1 according to AS/NZS 60695.11.10, provided that the relevant part is not thinner than the sample tested.</p>			
6.202.4	<p>Testing in the event of non-extinguishing material</p> <p>If parts, other than enclosures, do not withstand the glow wire tests of Clause 6.202.3, by failure to extinguish within 30 s after the removal of the glowwire tip, the needle-flame test detailed in Clause 6.202.3 shall be made on all parts of non-metallic material which are within a distance of 50 mm or which are likely to be impinged upon by flame during the tests of Clause 6.202.3. Parts shielded by a separate barrier which meets the needle-flame test need not be tested.</p> <p>NOTE 1: If the enclosure does not withstand the glow-wire test the equipment is considered to have failed to meet the</p>			N/A

IEC 62368_1D ATTACHMENT			
Clause	Requirement + Test	Result - Remark	Verdict
	<p>requirements of Clause 6.202 without the need for consequential testing.</p> <p>NOTE 2: If other parts do not withstand the glow-wire test due to ignition of the tissue paper and if this indicates that burning or glowing particles can fall onto an external surface underneath the equipment, the equipment is considered to have failed to meet the requirements of Clause 6.202 without the need for consequential testing.</p> <p>NOTE 3: Parts likely to be impinged upon by the flame are considered to be those within the envelope of a vertical cylinder having a radius of 10 mm and a height equal to the height of the flame, positioned above the point of the material supporting, in contact with, or in close proximity to, connections.</p>		
6.202.5	<p>Testing of printed boards</p> <p>The base material of printed boards shall be subjected to the needle-flame test of Clause 6.202.3. The flame shall be applied to the edge of the board where the heat sink effect is lowest when the board is positioned as in normal use. The flame shall not be applied to an edge, consisting of broken perforations, unless the edge is less than 3 mm from a potential ignition source.</p> <p>The test is not carried out if—</p> <ul style="list-style-type: none"> – the printed board does not carry any potential ignition source; – the base material of printed boards, on which the available apparent power at a connection exceeds 15 VA operating at a voltage exceeding 50 V and equal or less than 400 V (peak) a.c. or d.c. under normal operating conditions, is of flammability category V-1 or better according to AS/NZS 60695.11.10, or the printed boards are protected by an enclosure meeting the flammability category V-0 according to AS/NZS 60695.11.10, or made of metal, having openings only for connecting wires which fill the openings completely; or – the base material of printed boards, on which the available equipment power at a connection exceeds 15 VA operating at a voltage exceeding 400 V (peak) a.c. or d.c. under normal operating conditions, and base material of printed boards supporting spark gaps which provides protection against overvoltages, is of flammability category V-0 according to AS/NZS 60695.11.10 or the printed boards are contained in a metal enclosure, having openings only for connecting wires which fill the openings completely. <p><i>Conformance shall be determined using the smallest thickness of the material.</i></p> <p>NOTE: Available apparent power is the maximum apparent power which can be drawn from the supplying circuit through a resistive load whose value is chosen to maximize the apparent power for more than 2 min when the circuit supplied is disconnected.</p>		N/A
6.202.6	<p>For open circuit voltages greater than 4 kV</p> <p>Potential ignition sources with open circuit voltages exceeding 4 kV (peak) a.c. or d.c. under normal operating conditions shall be contained in a</p>		N/A

IEC 62368_1D ATTACHMENT			
Clause	Requirement + Test	Result - Remark	Verdict
	FIRE ENCLOSURE which shall comply with flammability category V-1 or better according to AS/NZS 60695.11.10.		
8.6.1.201	<p>8.6.1.201 Instructional safeguard for fixed-mount television sets</p> <p>MS2 and MS3 television sets and display devices designed only for fixed mounting to a wall of ceiling or equipment rack shall, where required in Table 36, footnote 201, have an instructional safeguard in accordance with Clause F.5 which may be on the equipment or included in the installation instructions or equivalent document accompanying the equipment.</p> <p>The elements of the instructional safeguard shall be as follows:</p> <ul style="list-style-type: none"> – element 1a: not available; – element 2: 'Stability Hazard' or equivalent wording; – element 3: 'The television set may fall, causing serious personal injury or death' or equivalent text; – element 4: the following or equivalent text: To prevent injury, this television set must be securely attached to the floor/wall in accordance with the installation instructions 		N/A
8.6.1.202	<p>Restraining device</p> <p>MS2 and MS3 television sets and display devices that are not solely fixed-mounted should be provided with a restraining device such as a fixing point to facilitate restraining the equipment from toppling forward. The restraining device shall be capable of withstanding a pull of 100 N in all directions without damage.</p> <p>Where a restraining device is provided, instructions shall be provided in the instructions for installation or instructions for use to ensure correct and safe installation.</p>		N/A

Report No.:

AS/NZS 3112:2017 Appendix J			
Clause	Requirement + Test	Result - Remark	Verdict
ATTACHMENT TO TEST REPORT AS_NZS_3112:2017_+A1:2021 Appendix J AUSTRALIAN / NEW ZEALAND NATIONAL DIFFERENCES (Approval and test specification—Plugs and socket-outlets)			
Differences according to : AS_NZS_3112:2017_Amendment 1:2021_Appendix J			
TRF template used:..... : IECEE OD-2020-F3, Ed. 1.1			
Attachment Form No. : AS_NZS_3112:2017_Appendix J			
Attachment Originator : JAS-ANZ			
Master Attachment..... : 2022-06			
Copyright © 2020 IEC System for Conformity Testing and Certification of Electrical Equipment (IECEE), Geneva, Switzerland. All rights reserved.			
Attachment not required. Appendix and related clauses not applicable to the product. Product will be provided with suitable detachable supply cord.			



Report reference No.: 071-75952029-010

Attachment 4

Record Photographs

Attachment 4

Editor: Dyke, Rebecca - 13 Jun 2022 4:22:44 PM
Content Review: Emery, Matthew - 20 Jun 2022 6:34:52 PM
QM Review: Tee, Trudi - 21 Jun 2022 10:39:58 AM
Release: Dyke, Rebecca - 04 Jul 2022 10:43:24 AM

Revision: 4
Effective date: 04 Jul 2022
Page 1 of 4
Doc ID: 107007

**Photo Attachment
Product Service**



Report reference No.: 071-75952029-010



BT HOS DID – Front and side



BT HOS DID – Rear and side

Attachment 4

Editor:
Content Review:
QM Review:
Release:

Dyke, Rebecca - 13 Jun 2022 4:22:44 PM
Emery, Matthew - 20 Jun 2022 6:34:52 PM
Tee, Trudi - 21 Jun 2022 10:39:58 AM
Dyke, Rebecca - 04 Jul 2022 10:43:24 AM

Revision: 4
Effective date: 04 Jul 2022
Page 2 of 4
Doc ID: 107007

Report reference No.: 071-75952029-010



BT HOS DID – front with keyring

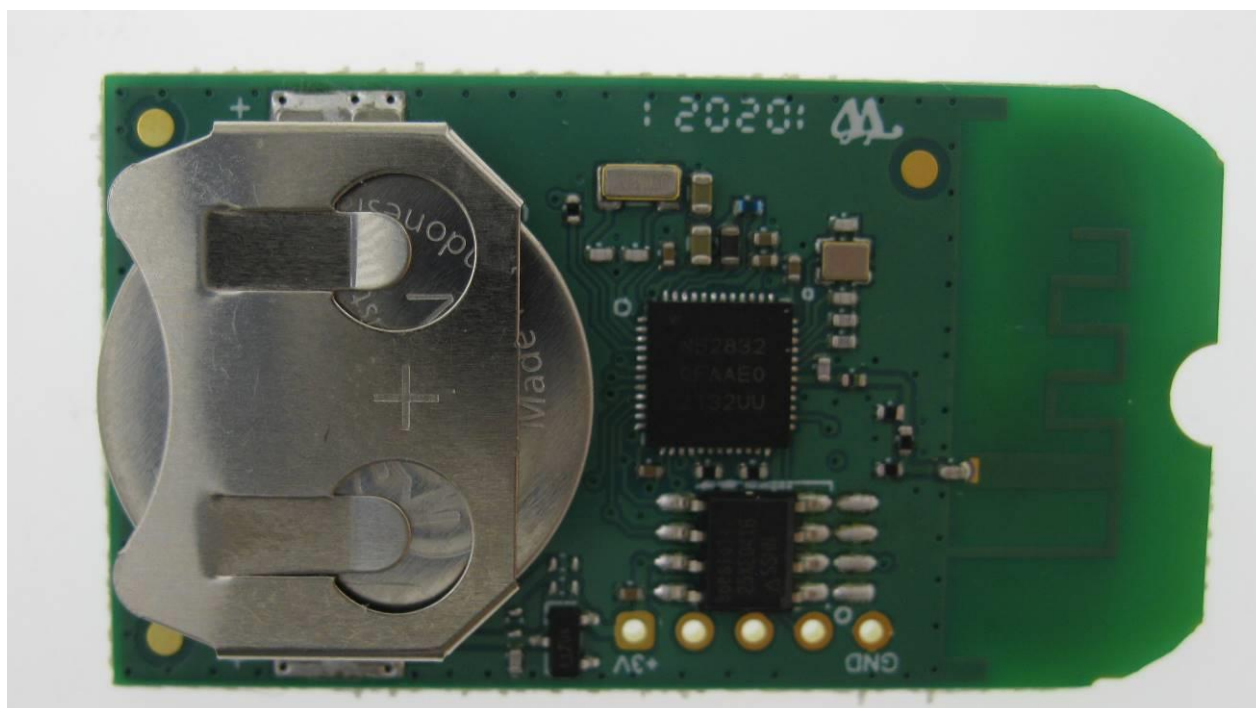

BT HOS DID – PCB front

Attachment 4

Editor:
Content Review:
QM Review:
Release:

Dyke, Rebecca - 13 Jun 2022 4:22:44 PM
Emery, Matthew - 20 Jun 2022 6:34:52 PM
Tee, Trudi - 21 Jun 2022 10:39:58 AM
Dyke, Rebecca - 04 Jul 2022 10:43:24 AM

Revision: 4
Effective date: 04 Jul 2022
Page 3 of 4
Doc ID: 107007

Photo Attachment
Product Service



Report reference No.: 071-75952029-010

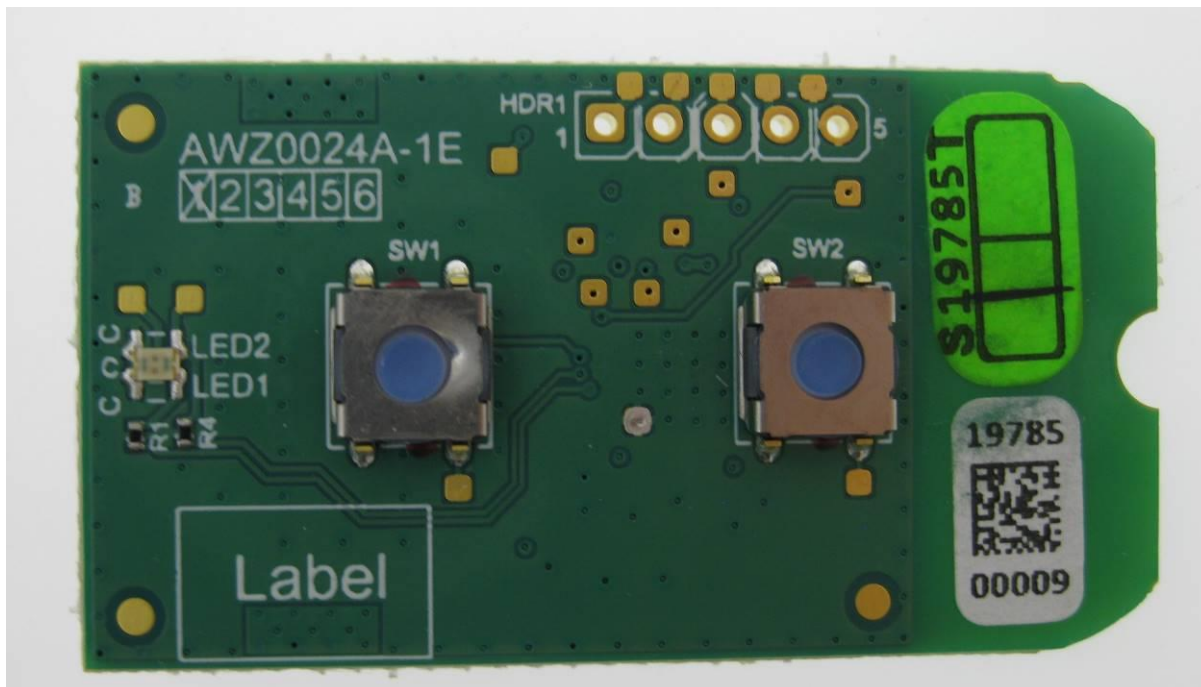

BT HOS DID – PCB rear

Attachment 4

Editor: Dyke, Rebecca - 13 Jun 2022 4:22:44 PM
Content Review: Emery, Matthew - 20 Jun 2022 6:34:52 PM
QM Review: Tee, Trudi - 21 Jun 2022 10:39:58 AM
Release: Dyke, Rebecca - 04 Jul 2022 10:43:24 AM

Revision: 4
Effective date: 04 Jul 2022
Page 4 of 4
Doc ID: 107007