



FCC Part 15C Test Report

FCC ID: 2AFL4FX140AD

Product Name:	11AC 433M DualBand Wireless USB Adapter
Trademark:	N/A
Model Name :	FX-WL140ACU-D
Prepared For :	Cerevo Inc.
Address :	12F Fujisoft Akihabara Bldg.,3 Kandaneibeicho, Chiyoda-ku,Tokyo,Japan
Prepared By :	Shenzhen BCTC Technology Co., Ltd.
Address :	No.101,Yousong Road,Longhua New District, Shenzhen,China
Test Date:	Aug. 2 - Aug. 15, 2015
Date of Report :	Aug. 16, 2015
Report No.:	BCTC-15080192



VERIFICATION OF COMPLIANCE

Applicant's name : **Cerevo Inc.**

Address..... : 12F Fujisoft Akihabara Bldg.,3 Kandaneribei-cho,
Chiyoda-ku,Tokyo,Japan

Manufacture's Name : **Liling FullRiver Electronics & Technology Ltd.**

Address..... : FullRiver Industrial Area Economic, Development zone,
liling city, Hunan Province, China

Product description

Product name..... : 11AC 433M DualBand Wireless USB Adapter

Trademark: N/A

Model Name: FX-WL140ACU-D

Test procedure FCC Part15.407

Standards ANSI C63.10-2013

This device described above has been tested by BCTC, and the test results show that the equipment under test (EUT) is in compliance with the FCC requirements. And it is applicable only to the tested sample identified in the report.

This report shall not be reproduced except in full, without the written approval of BCTC, this document may be altered or revised by BCTC, personal only, and shall be noted in the revision of the document.

Test Result : **Pass**

Testing Engineer : Eric Yang
(Eric Yang)

Technical Manager : Sophie Lee
(Sophia Lee)

Authorized Signatory : Carson Zhang
(Carson. Zhang)





TABLE OF CONTENTS

	Page
Test Report Declaration	
1. TEST SUMMARY	4
2. GENERAL PRODUCT INFORMATION	5
2.1. Product Function.....	5
2.2. Description of Device (EUT)	5
2.3. Test Supporting System.....	5
2.4. Independent Operation Modes	6
2.5. Test Sites	6
2.6. List of Test and Measurement Instruments.....	7
3. TEST SET-UP AND OPERATION MODES	8
3.1. Principle of Configuration Selection	8
3.2. Block Diagram of Test Set-up	8
3.3. Test Operation Mode and Test Software.....	8
3.4. Special Accessories and Auxiliary Equipment	8
3.5. Countermeasures to Achieve EMC Compliance.....	8
4. EMISSION TEST RESULTS	9
4.1. Conducted Emission Measurement	9
4.2. Radiated Emission Measurement	13
5. BAND EDGE COMPLIANCE TEST	24
5.1. Limits.....	24
5.2. Test setup.....	24
5.3. Test Data.....	24
6. 26DB AND 99% BANDWIDTH TEST	25
6.1. Measurement Procedure	25
7. OUTPUT POWER TEST	31
7.1. Limits.....	31
7.2. Test setup.....	31
7.3. Test result.....	31
8. PEAK POWER SPECTRAL DENSITY TEST	32
8.1. Limits.....	32
8.2. Test setup.....	32
8.3. Test data	32
9. DUTY CYCLE OF TEST SIGNAL	38
9.1. STANDARD REQUIREMENT	38
9.2. Formula:.....	38
10. PHOTOGRAPHS OF TEST SET-UP	41
11. PHOTOGRAPHS OF THE EUT	43



1. TEST SUMMARY

Test Items	Test Requirement	Result
Conducted Emissions	15.207	PASS
Radiated Emissions	15.407(b), 15.209	PASS
26dB bandwidth and 99%dB Bandwidth	15.407 (a)	PASS
Power density	15.407 (a)	PASS
Maximum Peak Output Power	15.407 (a)	PASS
Emissions from out of band	15.407 (b)	PASS
Antenna Requirement	15.203	PASS



2.GENERAL PRODUCT INFORMATION

2.1. Product Function

Refer to Technical Construction Form and User Manual.

2.2. Description of Device (EUT)

Product Name:	11AC 433M DualBand Wireless USB Adapter
Model No.:	FX-WL140ACU-D
Operation Frequency:	5180-5240 MHz(5G 802.11a/n(HT20)) 5190-5230 MHz(802.11n(HT40))
Channel numbers:	4channels for 5G 802.11a/n(HT20) 2channels for 802.11n(HT40) 1 channels for 802.11ac
Modulation technology:	Orthogonal Frequency Division Multiplexing(OFDM)
Data speed (IEEE 802.11g):	6Mbps, 9Mbps, 12Mbps, 18Mbps, 24Mbps, 36Mbps, 48Mbps,54Mbps
Data speed (IEEE 802.11n):	Up to 433Mbps
Antenna Type:	Internal Antenna
Antenna gain:	0.5dBi for (declare by Applicant)
Power supply:	DC 5V from PC

2.3. Test Supporting System

None.



2.4. Independent Operation Modes

The basic operation modes are:

These is Digital Transmission system (DTS) and have modulation OFDM, DSSS, DBPSK, DQPSK, CCK, 16QAM, 64QAM. According exploratory test, EUT will have maximum output power in those data rate (802.11a/n: MCS0), so those data rate were used for all test. The equipment enables high-speed access without wires to network assets. This adapter uses the IEEE 802.11 protocol to enable wireless communications between the host and Wireless router.

For 802.11a/n(HT20):

1. lowest channel : 5180MHz (Channel 36)
2. middle channel : 5220MHz (Channel 44)
3. highest channel : 5240MHz (Channel 165)

For 802.11n(HT40):

4. lowest channel : 5190MHz (Channel 38)
5. For highest channel : 5230MHz (Channel 46)

For 802.11n(HT40):

6. lowest channel : 5210MHz (Channel 42)

Note: for conducted emission test, we pretest all mode, the worst mode was 802.11a channel 36.

for radiated emissions test, we pretest all mode, the worst mode was 802.11a.

The worst mode's data was recording and show in the test report.

2.5. Test Sites

2.5.1. Test Facilities

Lab Qualifications : FCC Registration No.:187086



2.6. List of Test and Measurement Instruments

Conduction test equipment

Item	Kind of Equipment	Manufacturer	Type No.	Serial No.	Last calibration	Calibrated until	Calibration period
1	Test Receiver	R&S	ESCI	1166.5950K03-101165-ha	2015.07.06	2016.07.06	1 year
2	LISN	R&S	NSLK8126	8126466	2014.08.24	2015.08.23	1 year
3	LISN	R&S	NSLK8126	8126487	2014.08.24	2015.08.23	1 year
4	50Ω Coaxial Switch	Anritsu	MP59B	6200264417	2015.07.06	2016.07.06	1 year
5	RF cables	R&S	R204	R20X	2015.07.06	2016.07.06	1 year

Radiation test, Band-edge test and 26db bandwidth test equipment

Item	Kind of equipment	Manufacturer	Type No.	Serial No.	Last calibration	Calibrated until	Calibration period
1	Spectrum Analyzer	Agilent	E4407B	MY45108040	2015.07.06	2016.07.06	1 year
2	Test Receiver	R&S	ESPI	101318	2015.07.06	2016.07.06	1 year
3	Bilog Antenna	R&S	VULB9168	VULB9168-438	2015.07.06	2016.07.06	1 year
4	50Ω Coaxial Switch	Anritsu	MP59B	6200264416	2015.07.06	2016.07.06	1 year
5	Spectrum Analyzer	ADVANTEST	R3132	150900201	2015.07.06	2016.07.06	1 year
6	Horn Antenna	R&S	HF906	10027	2015.07.06	2016.07.06	1 year
7	Horn Ant	Schwarzbeck	BBHA 9170	9170-181	2015.07.06	2016.07.06	1 year
8	Amplifier	R&S	BBV9743	9743-019	2014.12.22	2015.12.21	1 year
9	Loop Antenna	ARA	PLA-1030/B	1029	2015.07.06	2016.07.06	1 year
10	RF cables	R&S	R203	R20X	2015.07.06	2016.07.06	1 year
11	Antenna connector	Florida RFLabs	Lab-Fle	RF 01#	2015.07.06	2016.07.06	1 year

3. TEST SET-UP AND OPERATION MODES

3.1. Principle of Configuration Selection

Emission: The equipment under test (EUT) was configured to measure its highest possible radiation level. The test modes were adapted accordingly in reference to the Operating Instructions.

3.2. Block Diagram of Test Set-up

System Diagram of Connections between EUT and Simulators

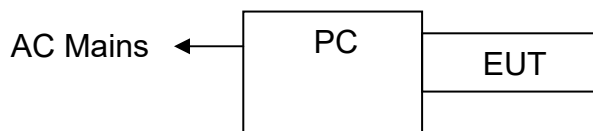

(EUT: 11AC 433M DualBand Wireless USB Adapter)

3.3. Test Operation Mode and Test Software

None.

3.4. Special Accessories and Auxiliary Equipment

None.

3.5. Countermeasures to Achieve EMC Compliance

None.



4. EMISSION TEST RESULTS

4.1. Conducted Emission Measurement

POWER LINE CONDUCTED EMISSION Limits (Frequency Range 150KHz-30MHz)

FREQUENCY (MHz)	Class B (dBuV)		Standard
	Quasi -peak	Average	
0.15 -0.5	66 - 56 *	56 - 46 *	FCC
0.50 -5.0	56.00	46.00	FCC
5.0 -30.0	60.00	50.00	FCC

Note:

- (1) The tighter limit applies at the band edges.
- (2) The limit of " * " marked band means the limitation decreases linearly with the logarithm of the frequency in the range.

The following table is the setting of the receiver

Receiver Parameters	Setting
Attenuation	10 dB
Start Frequency	0.15 MHz
Stop Frequency	30 MHz
IF Bandwidth	9 kHz

4.1.1. TEST PROCEDURE

- The EUT was placed 0.8 meters from the horizontal ground plane with EUT being connected to the power mains through a line impedance stabilization network (LISN). All other support equipments powered from additional LISN(s). The LISN provide 50 Ohm/ 50uH of coupling impedance for the measuring instrument.
- Interconnecting cables that hang closer than 40 cm to the ground plane shall be folded back and forth in the center forming a bundle 30 to 40 cm long.
- I/O cables that are not connected to a peripheral shall be bundled in the center. The end of the cable may be terminated, if required, using the correct terminating impedance. The overall length shall not exceed 1 m.
- LISN at least 80 cm from nearest part of EUT chassis.
- For the actual test configuration, please refer to the related Item –EUT Test Photos.

4.1.2. DEVIATION FROM TEST STANDARD

No deviation

4.1.3. TEST SETUP

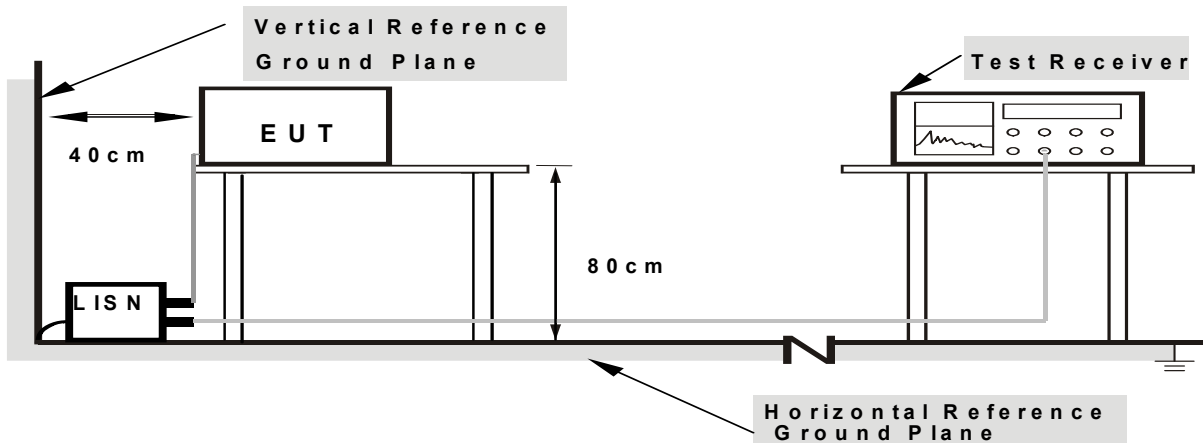

- Note:**
- Support units were connected to second LISN.
 - Both of LISNs (AMN) are 80 cm from EUT and at least 80 cm from other units and other metal planes

4.1.4. EUT OPERATING CONDITIONS

The EUT was configured for testing in a typical fashion (as a customer would normally use it). The EUT has been programmed to continuously transmit during test. This operating condition was tested and used to collect the included data.

We pretest all adapter's emission, only the adapter 1's data was worst and the data was recording in the report.

The data only show the worst mode.

If peak level comply with Quasi-Peak limit, then the Quasi-Peak level is deemed to comply with Quasi-Peak limit.

We pretest AC 120V and AC 240V, the worst voltage was AC 120V and the data recording in the report.



4.1.5. TEST RESULTS

EUT:	11AC 433M DualBand Wireless USB Adapter	Model Name :	FX-WL140ACU-D
Temperature:	26 °C	Relative Humidity:	54%
Pressure:	1010hPa	Phase :	L
Test Voltage :	DC 5V from PC input AC 120V/60Hz	Test Mode:	TX Mode

Frequency (MHz)	Meter Reading (dBμV)	Factor (dB)	Emission Level (dBμV)	Limits (dBμV)	Margin (dB)	Detector Type
0.4860	41.73	10.11	51.84	56.24	-4.40	QP
0.4860	28.39	10.11	38.50	46.24	-7.74	AVG
0.9580	38.83	10.16	48.99	56.00	-7.01	QP
0.9580	24.13	10.16	34.29	46.00	-11.71	AVG
1.5060	36.47	10.17	46.64	56.00	-9.36	QP
1.5060	23.07	10.17	33.24	46.00	-12.76	AVG
2.1660	35.58	10.18	45.76	56.00	-10.24	QP
2.1660	22.82	10.18	33.00	46.00	-13.00	AVG
3.2820	35.61	10.18	45.79	56.00	-10.21	QP
3.2820	20.73	10.18	30.91	46.00	-15.09	AVG
4.6420	32.59	10.15	42.74	56.00	-13.26	QP
4.6420	19.62	10.15	29.77	46.00	-16.23	AVG

Remark:

1. All readings are Quasi-Peak and Average values.
2. Factor = Insertion Loss + Cable Loss.

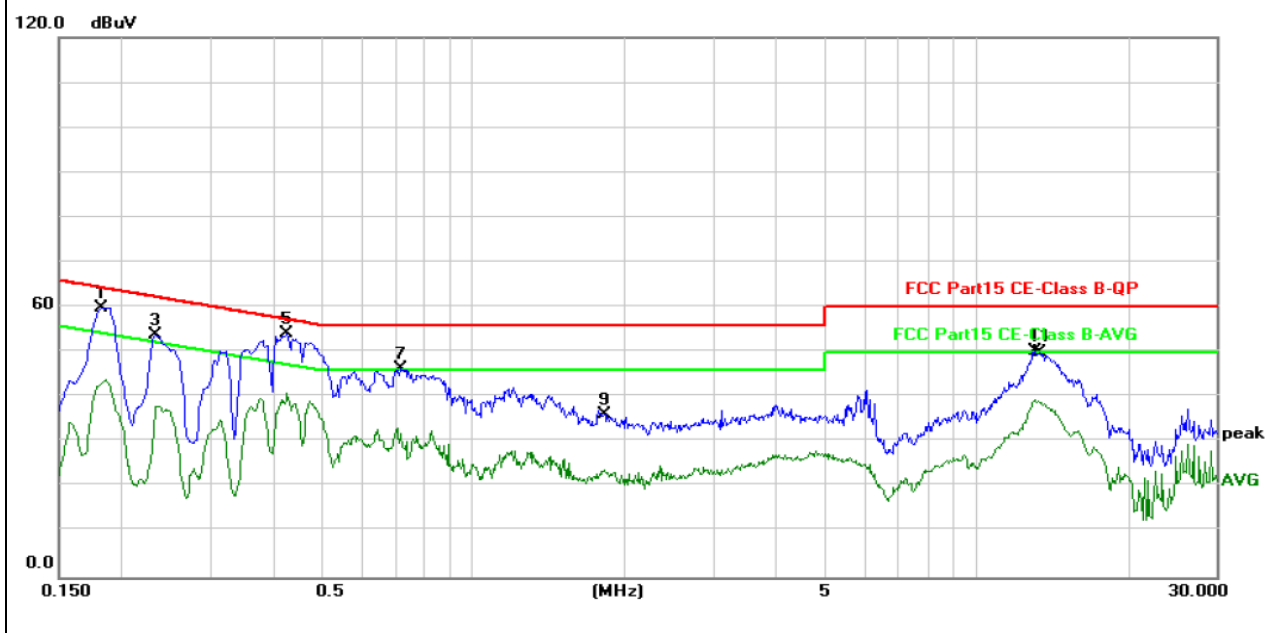



EUT:	11AC 433M DualBand Wireless USB Adapter	Model Name :	FX-WL140ACU-D
Temperature:	26 °C	Relative Humidity:	54%
Pressure:	1010hPa	Phase :	N
Test Voltage :	DC 5V from PC input AC 120V/60Hz	Test Mode:	TX Mode

Frequency (MHz)	Meter Reading (dBμV)	Factor (dB)	Emission Level (dBμV)	Limits (dBμV)	Margin (dB)	Detector Type
0.4900	38.01	10.11	48.12	56.17	-8.05	QP
0.4900	27.10	10.11	37.21	46.17	-8.96	AVG
0.9540	38.71	10.16	48.87	56.00	-7.13	QP
0.9540	21.82	10.16	31.98	46.00	-14.02	AVG
1.6660	32.94	10.18	43.12	56.00	-12.88	QP
1.6660	20.41	10.18	30.59	46.00	-15.41	AVG
2.2860	32.81	10.18	42.99	56.00	-13.01	QP
2.2860	19.90	10.18	30.08	46.00	-15.92	AVG
3.5740	31.29	10.17	41.46	56.00	-14.54	QP
3.5740	17.80	10.17	27.97	46.00	-18.03	AVG
4.7740	31.50	10.15	41.65	56.00	-14.35	QP
4.7740	17.07	10.15	27.22	46.00	-18.78	AVG

Remark:
 1. All readings are Quasi-Peak and Average values.
 2. Factor = Insertion Loss + Cable Loss.

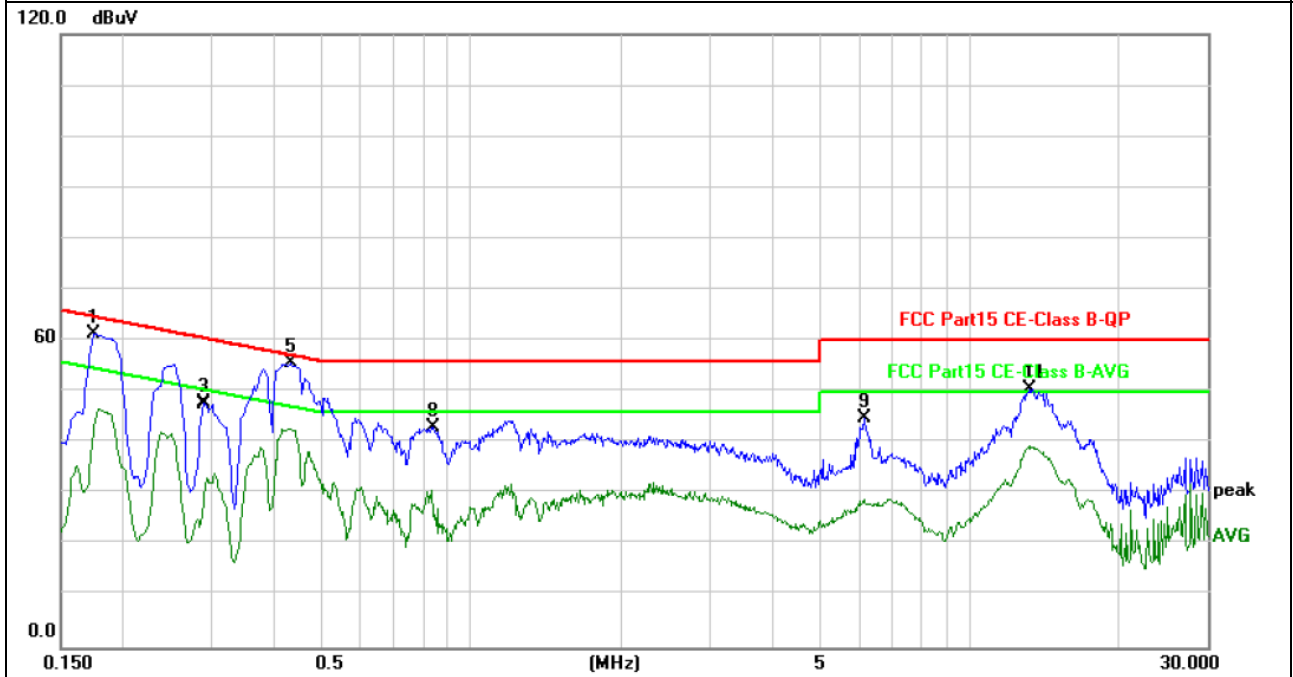



4.2. Radiated Emission Measurement

4.2.1. Radiated Emission Limits (Frequency Range 9kHz-1000MHz)

20dBc in any 100 kHz bandwidth outside the operating frequency band. In case the emission fall within the restricted band specified on 15.205(a), then the 15.209(a) limit in the table below has to be followed.

Frequencies (MHz)	Field Strength (microvolts/meter)	Measurement Distance (meters)
0.009~0.490	2400/F(KHz)	300
0.490~1.705	24000/F(KHz)	30
1.705~30.0	30	30
30~88	100	3
88~216	150	3
216~960	200	3
Above 960	500	3

LIMITS OF RADIATED EMISSION MEASUREMENT (Above 1000MHz)

FREQUENCY (MHz)	Class B (dBuV/m) (at 3M)	
	PEAK	AVERAGE
Above 1000	74	54

Notes:

- (1) The limit for radiated test was performed according to FCC PART 15C.
- (2) The tighter limit applies at the band edges.
- (3) Emission level (dBuV/m)=20log Emission level (uV/m).

FREQUENCY RANGE OF RADIATED MEASUREMENT (For unintentional radiators)

Highest frequency generated or Upper frequency of measurement used in the device or on which the device operates or tunes (MHz)	Range (MHz)
Below 1.705	30
1.705 – 108	1000
108 – 500	2000
500 – 1000	5000
Above 1000	5th harmonic of the highest frequency or 40 GHz, whichever is lower



Spectrum Parameter	Setting
Attenuation	Auto
Start Frequency	1000 MHz
Stop Frequency	10th carrier harmonic
RB / VB (emission in restricted band)	1 MHz / 1 MHz for Peak, 1 MHz / 10Hz for Average

Receiver Parameter	Setting
Attenuation	Auto
Start ~ Stop Frequency	9kHz~150kHz / RB 200Hz for QP
Start ~ Stop Frequency	150kHz~30MHz / RB 9kHz for QP
Start ~ Stop Frequency	30MHz~1000MHz / RB 120kHz for QP

4.2.2. TEST PROCEDURE

- a. The measuring distance of at 3 m shall be used for measurements at frequency up to 25GHz. For frequencies above 1GHz, any suitable measuring distance may be used.
- b. The EUT was placed on the top of a rotating table 1.5 meters above the ground at a 3 meter open area test site. The table was rotated 360 degrees to determine the position of the highest radiation.
- c. The height of the equipment or of the substitution antenna shall be 1.5 m; the height of the test antenna shall vary between 1 m to 4 m. Both horizontal and vertical polarizations of the antenna are set to make the measurement.
- d. The initial step in collecting conducted emission data is a spectrum analyzer peak detector mode pre-scanning the measurement frequency range. Significant peaks are then marked and then Quasi Peak detector mode re-measured.
- e. If the Peak Mode measured value compliance with and lower than Quasi Peak Mode Limit, the EUT shall be deemed to meet QP Limits and then no additional QP Mode measurement performed.
- f. For the actual test configuration, please refer to the related Item –EUT Test Photos.
- g. For the radiated emission test above 1GHz:
Place the measurement antenna away from each area of the EUT determined to be a source of emissions at the specified measurement distance, while keeping the measurement antenna aimed at the source of emissions at each frequency of significant emissions, with polarization oriented for maximum response.
The measurement antenna may have to be higher or lower than the EUT, depending on the radiation pattern of the emission and staying aimed at the emission source for receiving the maximum signal. The final measurement antenna elevation shall be that which maximizes the emissions. The measurement antenna elevation for maximum emissions shall be restricted to a range of heights of from 1 m to 4 m above the ground or reference ground plane.

Note:

Both horizontal and vertical antenna polarities were tested and performed pretest to three orthogonal axis. The worst case emissions were reported

We pretest AC 120V and AC 240V, the worst voltage was AC 120V and the data recording in the report.

4.2.3. DEVIATION FROM TEST STANDARD

No deviation

4.2.4. TEST SETUP

(A) Radiated Emission Test-Up Frequency Below 30MHz

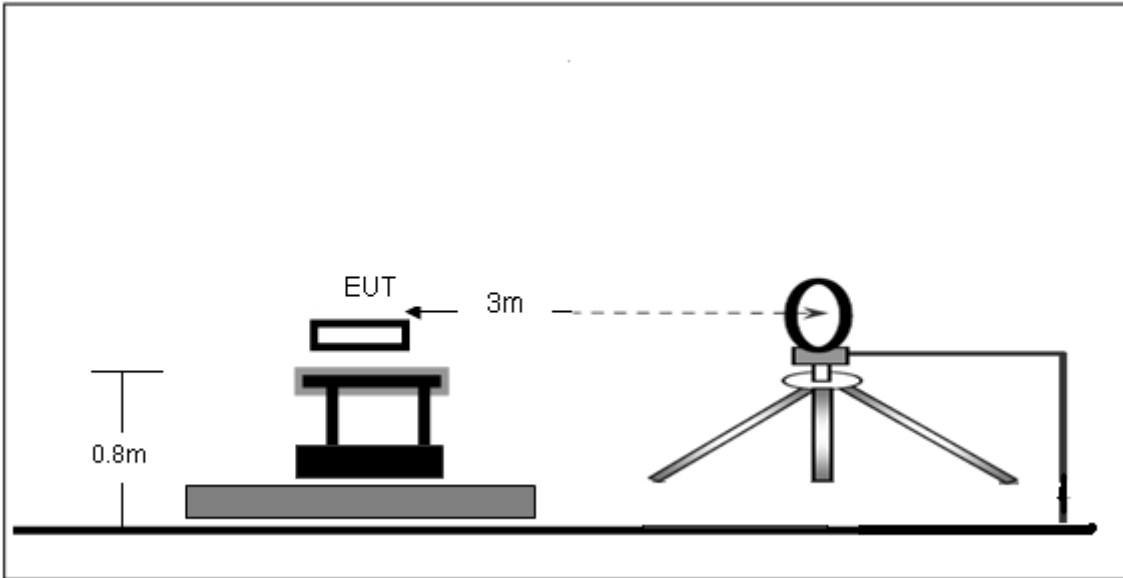

(B) Radiated Emission Test-Up Frequency 30MHz~1GHz

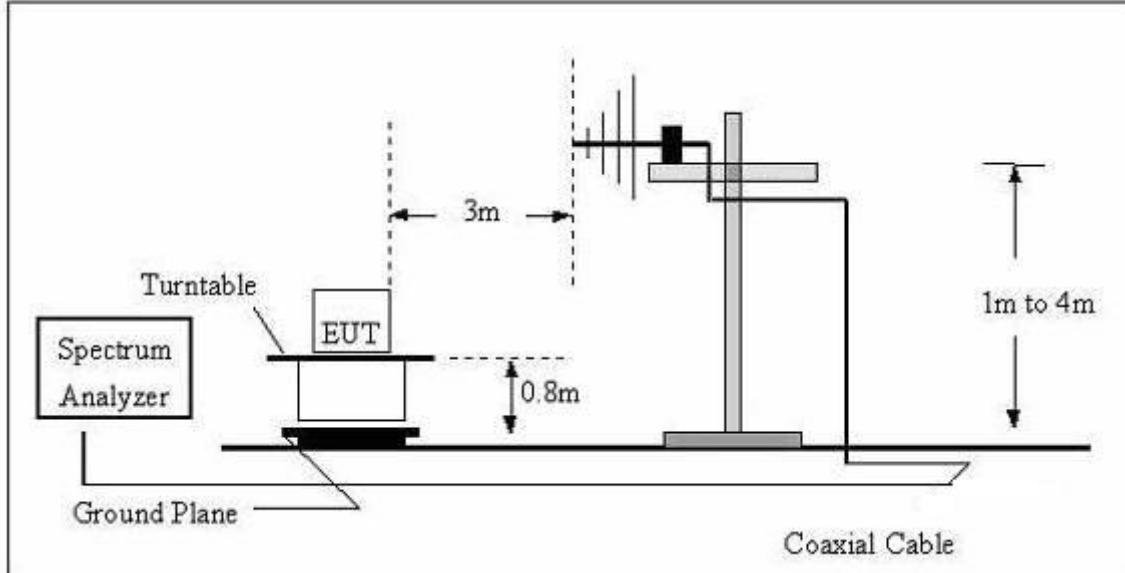

(C) Radiated Emission Test-Up Frequency Above 1GHz

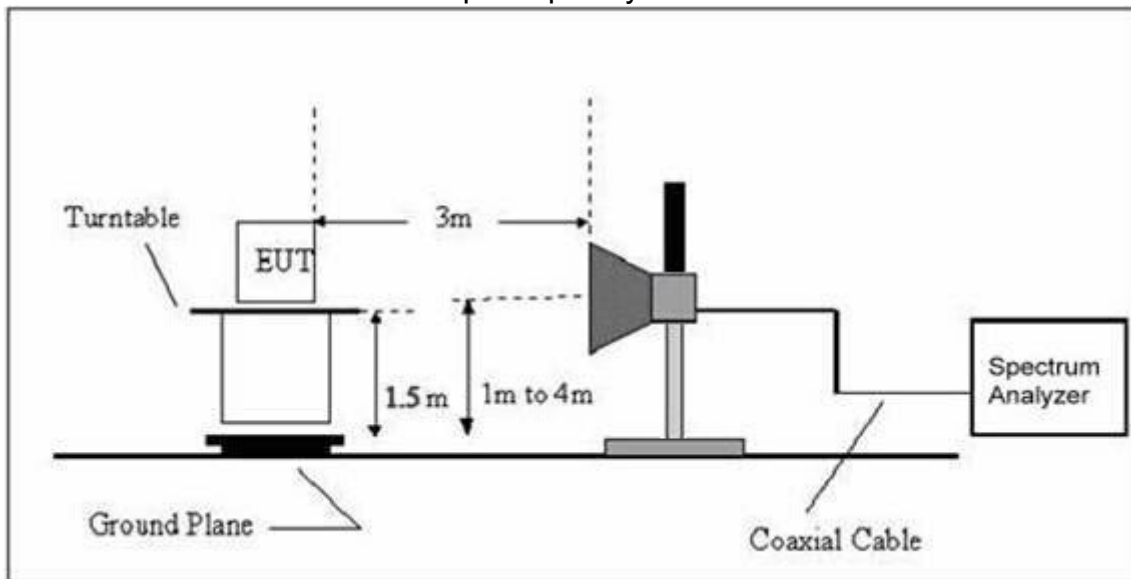

4.2.5. EUT OPERATING CONDITIONS

The EUT tested system was configured as the statements of 2.4 Unless otherwise a special operating condition is specified in the follows during the testing.

We pretest all adapter's emission, only the adapter 1's data was worst and the data was recording in the report.

The data only show the worst mode.



Radiated Spurious Emission (Below 30MHz)

EUT :	11AC 433M DualBand Wireless USB Adapter	Model Name :	FX-WL140ACU-D
Temperature :	20 °C	Relative Humidity :	48%
Pressure :	1010 hPa	Polarization :	---
Test Voltage :	DC 5V from PC input AC 120V/60Hz		
Test Mode :	TX		

Freq. (MHz)	Reading (dBuV/m)	Limit (dBuV/m)	Margin (dB)	State P/F
--	--	--	--	PASS
--	--	--	--	PASS

Note:

The amplitude of spurious emissions which are attenuated by more than 20dB below the permissible value has no need to be reported.

Distance extrapolation factor = $40 \log(\text{specific distance}/\text{test distance})$ (dB);

Limit line = specific limits(dBuv) + distance extrapolation factor.



Radiated Spurious Emission (Between 30MHz – 1GHz)

EUT :	11AC 433M DualBand Wireless USB Adapter	Model Name :	FX-WL140ACU-D
Temperature :	26 °C	Relative Humidity :	54%
Pressure :	1010 hPa	Polarization :	Horizontal
Test Voltage :	DC 5V from PC input AC 120V/60Hz		
Test Mode : (Worst)	802.11a low channel		

Frequency (MHz)	Meter Reading (dBµV)	Factor (dB)	Emission Level (dBµV/m)	Limits (dBµV/m)	Margin (dB)	Detector Type
180.0165	44.93	-14.34	30.59	43.50	-12.91	QP
190.4050	46.64	-15.61	31.03	43.50	-12.47	QP
228.4904	42.53	-15.14	27.39	46.00	-18.61	QP
419.1081	42.69	-9.76	32.93	46.00	-13.07	QP
647.3856	38.38	-5.12	33.26	46.00	-12.74	QP
687.1507	38.58	-4.59	33.99	46.00	-12.01	QP

Remark:

Factor = Antenna Factor + Cable Loss – Pre-amplifier.
 All interfaces was connected, and BT TX mode was link.

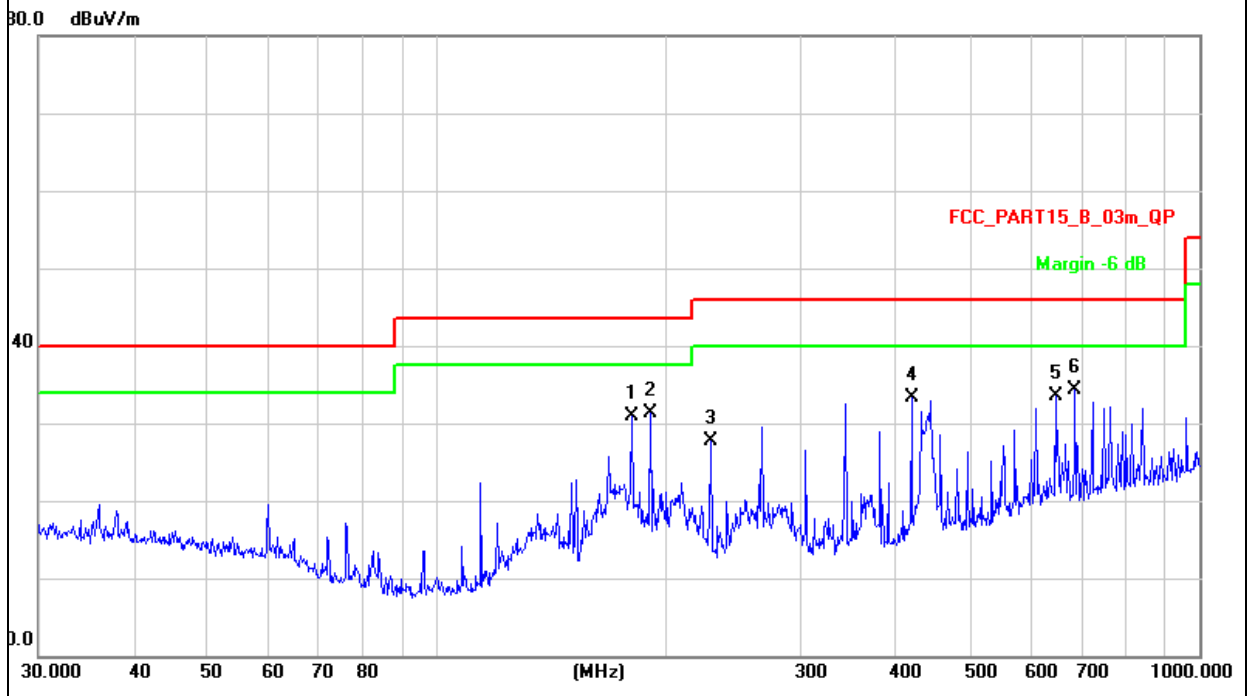



EUT :	11AC 433M DualBand Wireless USB Adapter	Model Name :	FX-WL140ACU-D
Temperature :	26 °C	Relative Humidity :	54%
Pressure :	1010 hPa	Polarization :	Vertical
Test Voltage :	DC 5V from PC input AC 120V/60Hz		
Test Mode : (Worst)	802.11a low channel		

Frequency (MHz)	Meter Reading (dBμV)	Factor (dB)	Emission Level (dBμV/m)	Limits (dBμV/m)	Margin (dB)	Detector Type
125.0066	52.85	-14.41	38.44	43.50	-5.06	QP
170.1947	46.97	-13.47	33.50	43.50	-10.00	QP
297.2241	51.12	-12.66	38.46	46.00	-7.54	QP
313.2760	48.34	-12.23	36.11	46.00	-9.89	QP
375.9384	48.24	-10.77	37.47	46.00	-8.53	QP
625.0779	45.06	-5.52	39.54	46.00	-6.46	QP

Remark:

Factor = Antenna Factor + Cable Loss – Pre-amplifier.
 All interfaces was connected, and BT TX mode was link.

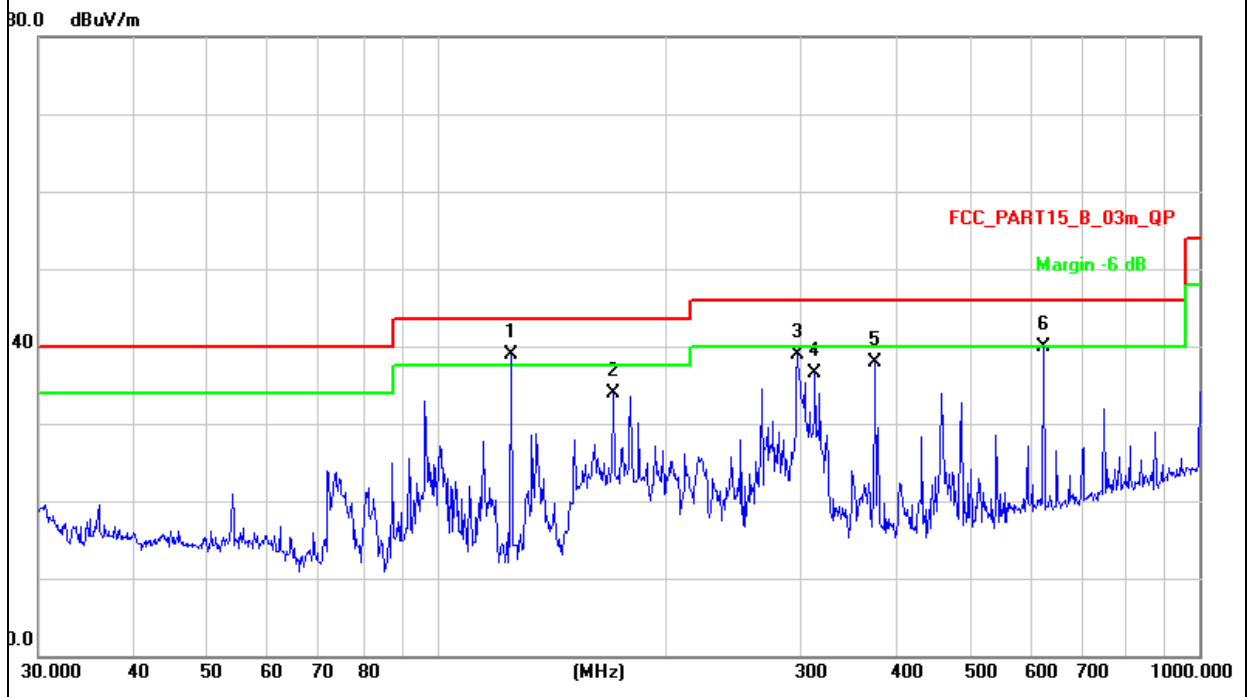



Radiated Spurious Emission (1GHz to 5th harmonics)
802.11a

	Freq.	Receiver Reading	Detector	Polar	Corrected Factor	Emission Level	Limit	Result
	(MHz)	(dBμV)	(PK/QP/Ave)	(H/V)	(dB)	(dBμV/m)	(dBμV/m)	
Lower Channel 5180MHz	10360.00	57.63	PK	H	2.32	59.95	74.00	Pass
	10360.00	48.47	Ave	H	2.32	50.79	54.00	Pass
	15540.00	59.33	PK	H	-2.15	57.18	74.00	Pass
	15540.00	48.41	Ave	H	-2.15	46.26	54.00	Pass
	10360.00	57.29	PK	V	2.32	59.61	74.00	Pass
	10360.00	48.30	Ave	V	2.32	50.62	54.00	Pass
	15540.00	59.57	PK	V	-2.15	57.42	74.00	Pass
	15540.00	48.61	Ave	V	-2.15	46.46	54.00	Pass
Middle Channel 5220MHz	10440.00	57.33	PK	H	2.54	59.87	74.00	Pass
	10440.00	48.21	Ave	H	2.54	50.75	54.00	Pass
	15660.00	59.87	PK	H	-1.98	57.89	74.00	Pass
	15660.00	48.22	Ave	H	-1.98	46.24	54.00	Pass
	10440.00	58.14	PK	V	2.54	60.68	74.00	Pass
	10440.00	49.21	Ave	V	2.54	51.75	54.00	Pass
	15660.00	59.62	PK	V	-1.98	57.64	74.00	Pass
	15660.00	48.51	Ave	V	-1.98	46.53	54.00	Pass
Upper Channel 5240MHz	10480.00	57.52	PK	H	2.68	60.20	74.00	Pass
	10480.00	48.03	Ave	H	2.68	50.71	54.00	Pass
	15720.00	59.86	PK	H	-1.27	58.59	74.00	Pass
	15720.00	48.52	Ave	H	-1.27	47.25	54.00	Pass
	10480.00	58.53	PK	V	2.68	61.21	74.00	Pass
	10480.00	47.84	Ave	V	2.68	50.52	54.00	Pass
	15720.00	59.91	PK	V	-1.27	58.64	74.00	Pass
	15720.00	48.67	Ave	V	-1.27	47.40	54.00	Pass

Remark:

Factor = Antenna Factor + Cable Loss – Pre-amplifier.

Emission Level = Meter Reading + Factor

Margin = Emission Level - Limit

Other harmonics emissions are lower than 20dB below the allowable limit.



802.11n(HT20)

	Freq.	Receiver Reading	Detector	Polar	Corrected Factor	Emission Level	Limit	Result
	(MHz)	(dBμV)	(PK/QP/Ave)	(H/V)	(dB)	(dBμV/m)	(dBμV/m)	
Lower Channel 5180MHz	10360.00	57.19	PK	H	2.32	59.51	74.00	Pass
	10360.00	48.10	Ave	H	2.32	50.42	54.00	Pass
	15540.00	58.88	PK	H	-2.15	56.73	74.00	Pass
	15540.00	48.04	Ave	H	-2.15	45.89	54.00	Pass
	10360.00	56.85	PK	V	2.32	59.17	74.00	Pass
	10360.00	47.93	Ave	V	2.32	50.25	54.00	Pass
	15540.00	59.12	PK	V	-2.15	56.97	74.00	Pass
	15540.00	48.24	Ave	V	-2.15	46.09	54.00	Pass
	Middle Channel 5220MHz	10440.00	56.89	PK	H	2.54	59.43	74.00
10440.00		47.84	Ave	H	2.54	50.38	54.00	Pass
15660.00		59.41	PK	H	-1.98	57.43	74.00	Pass
15660.00		47.85	Ave	H	-1.98	45.87	54.00	Pass
10440.00		57.70	PK	V	2.54	60.24	74.00	Pass
10440.00		48.84	Ave	V	2.54	51.38	54.00	Pass
15660.00		59.17	PK	V	-1.98	57.19	74.00	Pass
15660.00		48.14	Ave	V	-1.98	46.16	54.00	Pass
Upper Channel 5240MHz	10480.00	57.08	PK	H	2.68	59.76	74.00	Pass
	10480.00	47.66	Ave	H	2.68	50.34	54.00	Pass
	15720.00	59.41	PK	H	-1.27	58.14	74.00	Pass
	15720.00	48.15	Ave	H	-1.27	46.88	54.00	Pass
	10480.00	58.09	PK	V	2.68	60.77	74.00	Pass
	10480.00	47.48	Ave	V	2.68	50.16	54.00	Pass
	15720.00	59.45	PK	V	-1.27	58.18	74.00	Pass
	15720.00	48.30	Ave	V	-1.27	47.03	54.00	Pass

Remark:

Factor = Antenna Factor + Cable Loss – Pre-amplifier.

Emission Level = Meter Reading + Factor

Margin = Emission Level - Limit

Other harmonics emissions are lower than 20dB below the allowable limit.



802.11n(HT40)

	Freq.	Receiver Reading	Detector	Polar	Corrected Factor	Emission Level	Limit	Result
	(MHz)	(dBμV)	(PK/QP/Ave)	(H/V)	(dB)	(dBμV/m)	(dBμV/m)	
Lower Channel 5190MHz	10380.00	57.83	PK	H	2.43	60.26	114.00	Pass
	10380.00	48.64	Ave	H	2.43	51.07	94.00	Pass
	15570.00	59.54	PK	H	-1.97	57.57	74.00	Pass
	15570.00	48.58	Ave	H	-1.97	46.61	54.00	Pass
	10380.00	57.49	PK	V	2.43	59.92	114.00	Pass
	10380.00	48.47	Ave	V	2.43	50.90	94.00	Pass
	15570.00	59.78	PK	V	-1.97	57.81	74.00	Pass
	15570.00	48.78	Ave	V	-1.97	46.81	54.00	Pass
	Upper Channel 5230MHz	10460.00	57.53	PK	H	2.62	60.15	114.00
10460.00		48.38	Ave	H	2.62	51.00	94.00	Pass
15690.00		60.08	PK	H	-1.18	58.90	74.00	Pass
15690.00		48.39	Ave	H	-1.18	47.21	54.00	Pass
10460.00		58.34	PK	V	2.62	60.96	114.00	Pass
10460.00		49.38	Ave	V	2.62	52.00	94.00	Pass
15690.00		59.83	PK	V	-1.18	58.65	74.00	Pass
15690.00		48.68	Ave	V	-1.18	47.50	54.00	Pass

Remark:

Factor = Antenna Factor + Cable Loss – Pre-amplifier.

Emission Level = Meter Reading + Factor

Margin = Emission Level - Limit

Other harmonics emissions are lower than 20dB below the allowable limit.



802.11ac

	Freq.	Receiver Reading	Detector	Polar	Corrected Factor	Emission Level	Limit	Result
	(MHz)	(dB μ V)	(PK/QP/Ave)	(H/V)	(dB)	(dB μ V/m)	(dB μ V/m)	
5210MHz	10420.00	58.24	PK	H	2.57	60.81	114.00	Pass
	10420.00	49.26	Ave	H	2.57	51.83	94.00	Pass
	15630.00	58.97	PK	H	-1.66	57.31	74.00	Pass
	15630.00	48.46	Ave	H	-1.66	46.80	54.00	Pass
	10420.00	58.64	PK	V	2.57	61.21	114.00	Pass
	10420.00	49.52	Ave	V	2.57	52.09	94.00	Pass
	15630.00	59.19	PK	V	-1.66	57.53	74.00	Pass
	15630.00	48.36	Ave	V	-1.66	46.70	54.00	Pass

Remark:

Factor = Antenna Factor + Cable Loss – Pre-amplifier.

Emission Level = Meter Reading + Factor

Margin = Emission Level - Limit

Other harmonics emissions are lower than 20dB below the allowable limit.



5. BAND EDGE COMPLIANCE TEST

5.1. Limits

Band 5.15-5.25GHz:

FCC: For transmitters operating in the 5.15-5.25 GHz band: All emissions outside of the 5.15-5.35 GHz band shall not exceed an e.i.r.p. of -27 dBm/MHz

5.2. Test setup

Test method: FCC KDB 789033 G)& Parts 15.407(b)(4) & 15.209(a)

Same as Clause 4.2.

5.3. Test Data

Please see data as below:

Note: we pretest horizontal and vertical, the worst was horizontal and show in the report.

Modulation	Test Frequency (MHz)	Max Level (dB μ V/m)	EIRP[dBm]	Limit[dBm]	Result
802.11a	5180	50.39	-44.81	-27.00	Pass
	5240	50.37	-44.83	-27.00	Pass
802.11n(HT20)	5180	50.13	-45.07	-27.00	Pass
	5240	50.34	-44.86	-27.00	Pass
802.11n(HT40)	5190	50.29	-44.91	-27.00	Pass
	5230	50.50	-44.70	-27.00	Pass
802.11ac	5210	50.36	-44.84	-27.00	Pass

Remark: 1. According to KDB 789033 D02 section H) d) (iii), for measurement above 1000MHz@3m distance, the limit of EIRP is calculated as follows: $EIRP[dBm] = E[dB\mu V/m] - 95.2$



6. 26DB AND 99% BANDWIDTH TEST

6.1. Measurement Procedure

The bandwidth at 26 dB down from the highest in-band spectral density is measured with a spectrum analyzer connected to the antenna terminal while the EUT is operating at its maximum power control level, as defined in KDB 789033, at the appropriate frequencies. The spectrum analyzer's bandwidth measurement function is configured to measure the 26 dB bandwidth.

The 26 dB bandwidth is used to determine the conducted power limits.

The minimum of 6dB Bandwidth measurement is 0.5 MHz for U-NII-3

	Channel number	Frequency (MHz)	6dB Bandwidth (MHz)	99% Bandwidth (MHz)	Limit (MHz)
802.11a	36	5180	19.750	16.809	>0.5
	44	5220	19.610	16.766	>0.5
	48	5240	19.810	16.769	>0.5
802.11n (HT20)	36	5180	19.865	17.793	>0.5
	44	5220	19.729	17.800	>0.5
	48	5240	19.952	17.743	>0.5
802.11n (HT40)	38	5190	43.730	36.168	>0.5
	46	5230	46.630	36.195	>0.5
802.11ac	42	5210	80.440	75.351	>0.5



802.11a 5180MHz

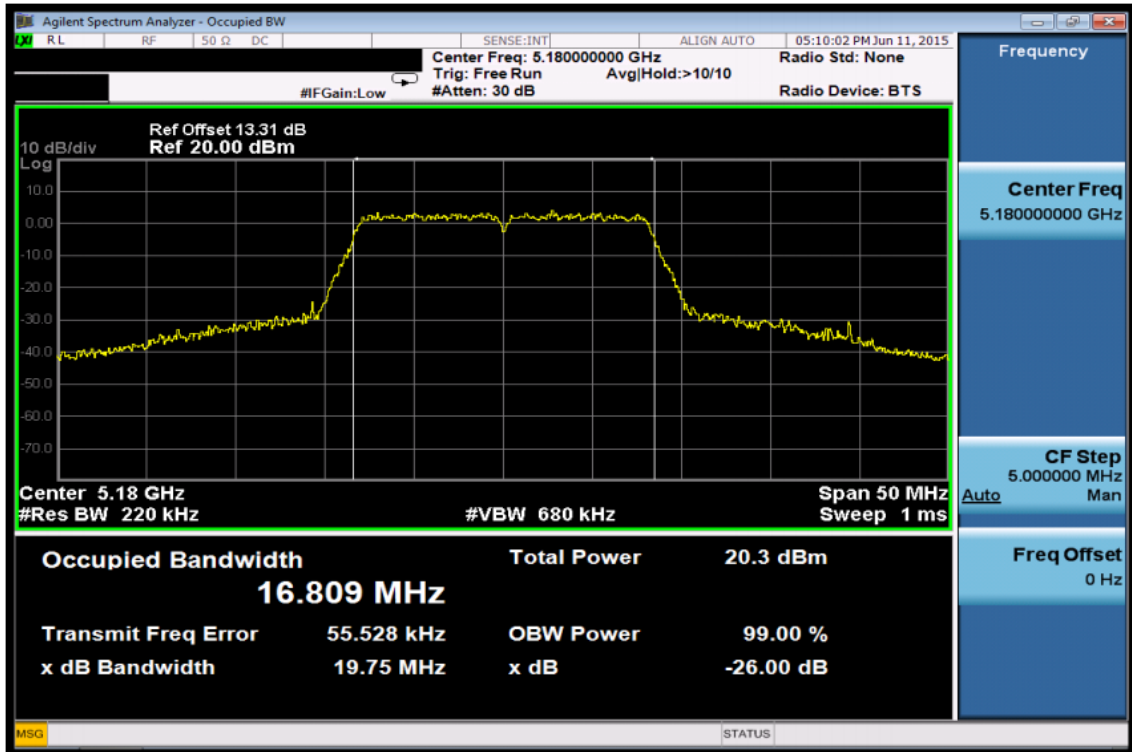

802.11a 5220MHz

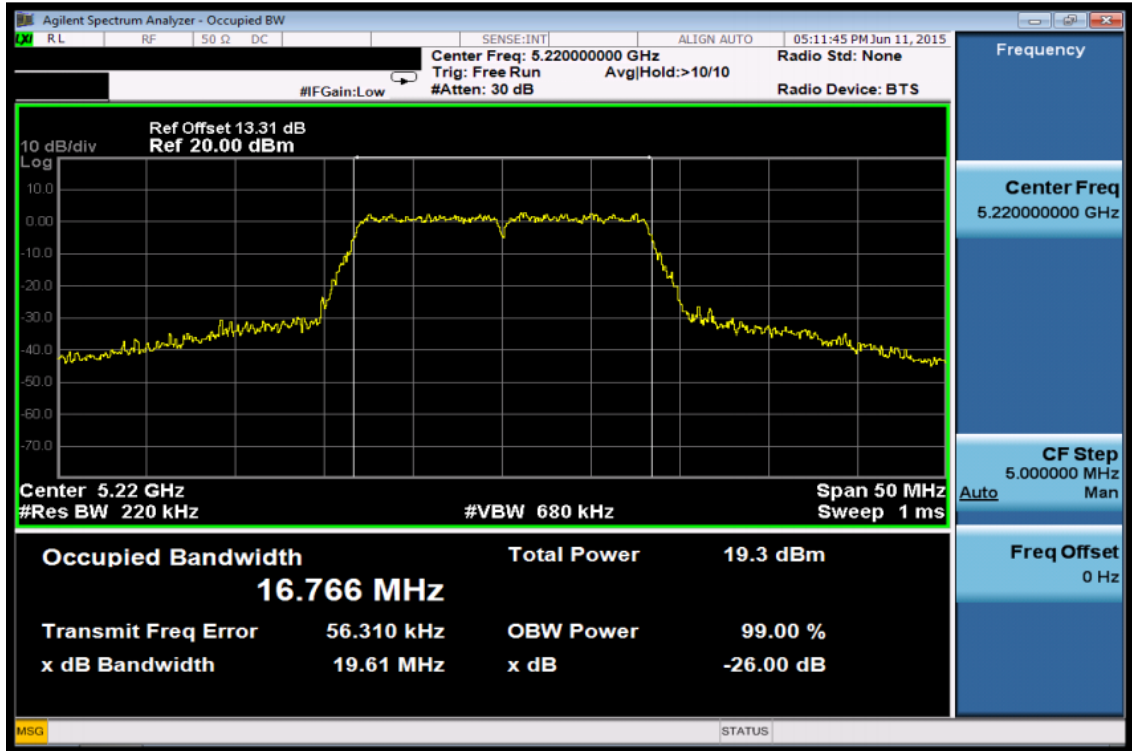



802.11a 5240MHz

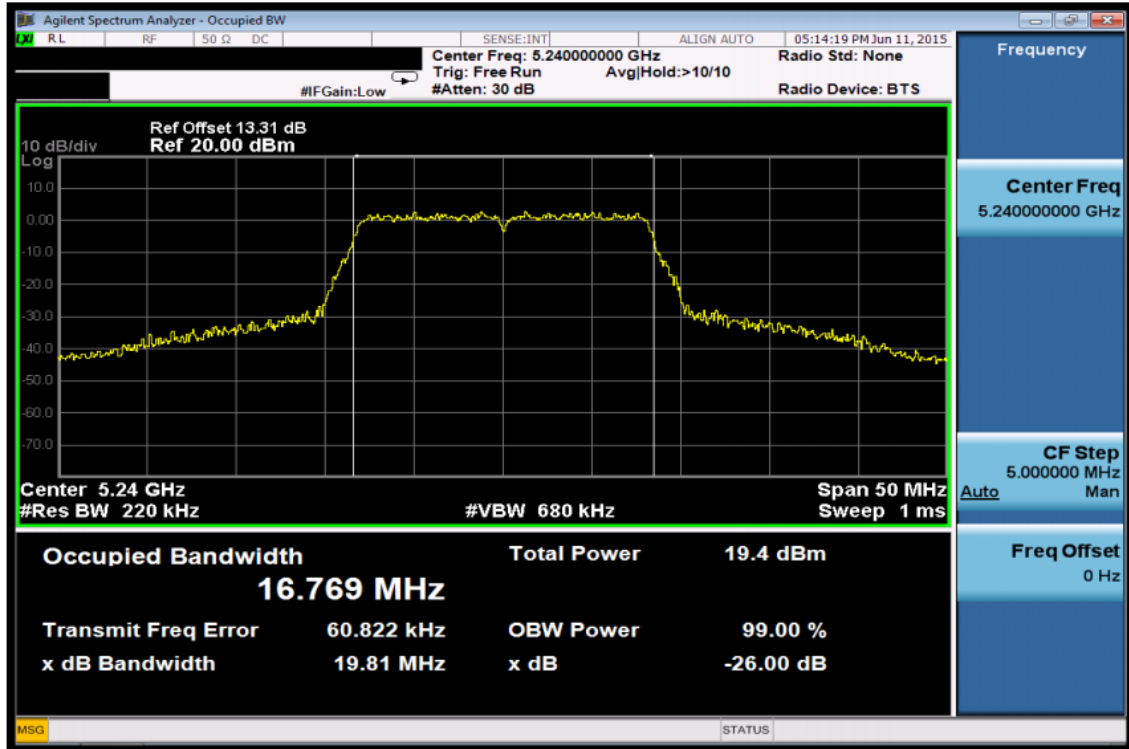

802.11n(HT20) 5180MHz

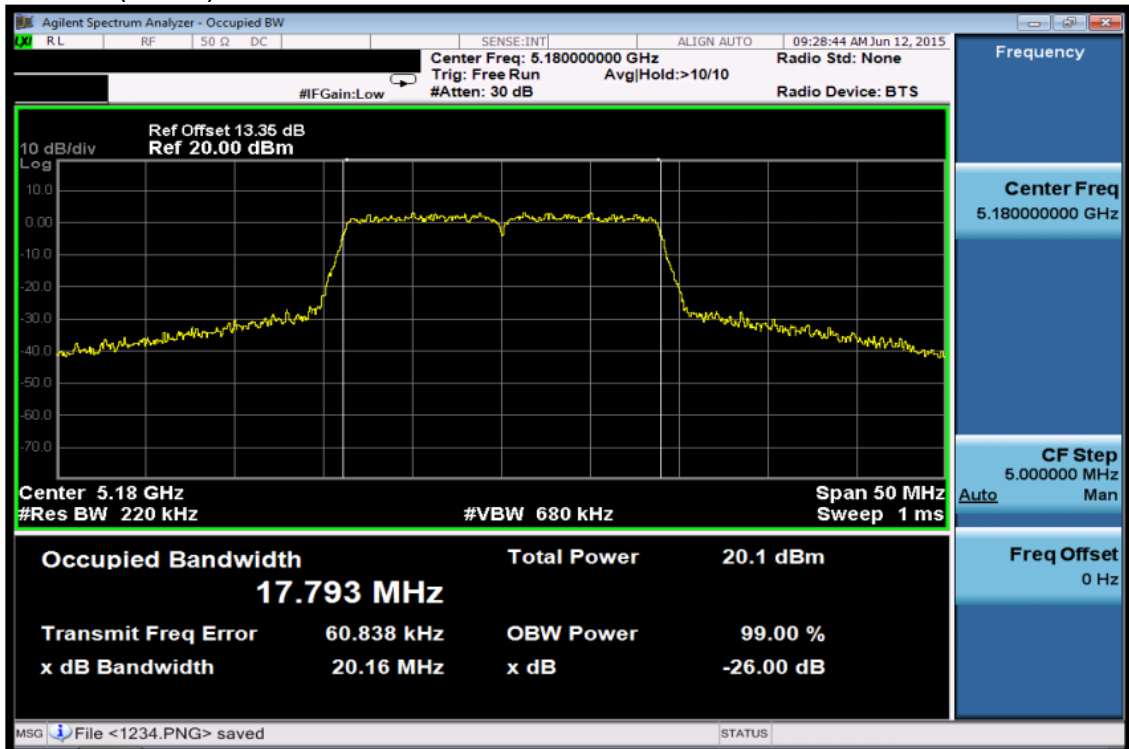



802.11n(HT20) 5220MHz

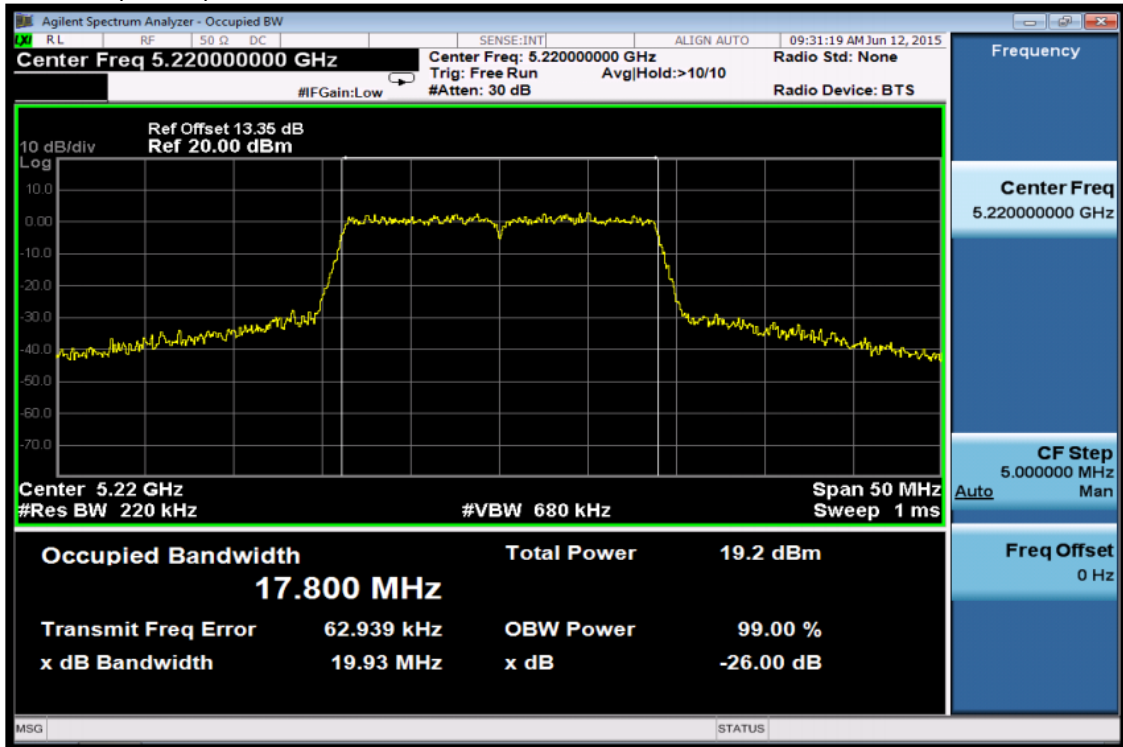

802.11n(HT20) 5240MHz

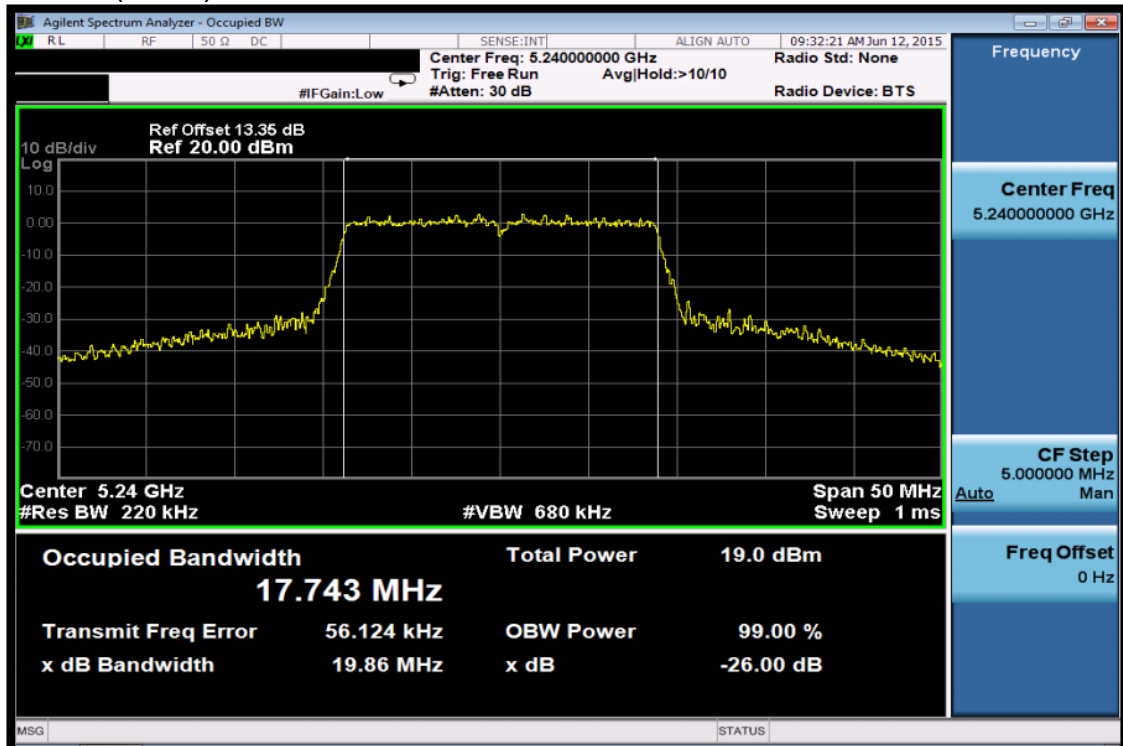



802.11n(HT40) 5190MHz

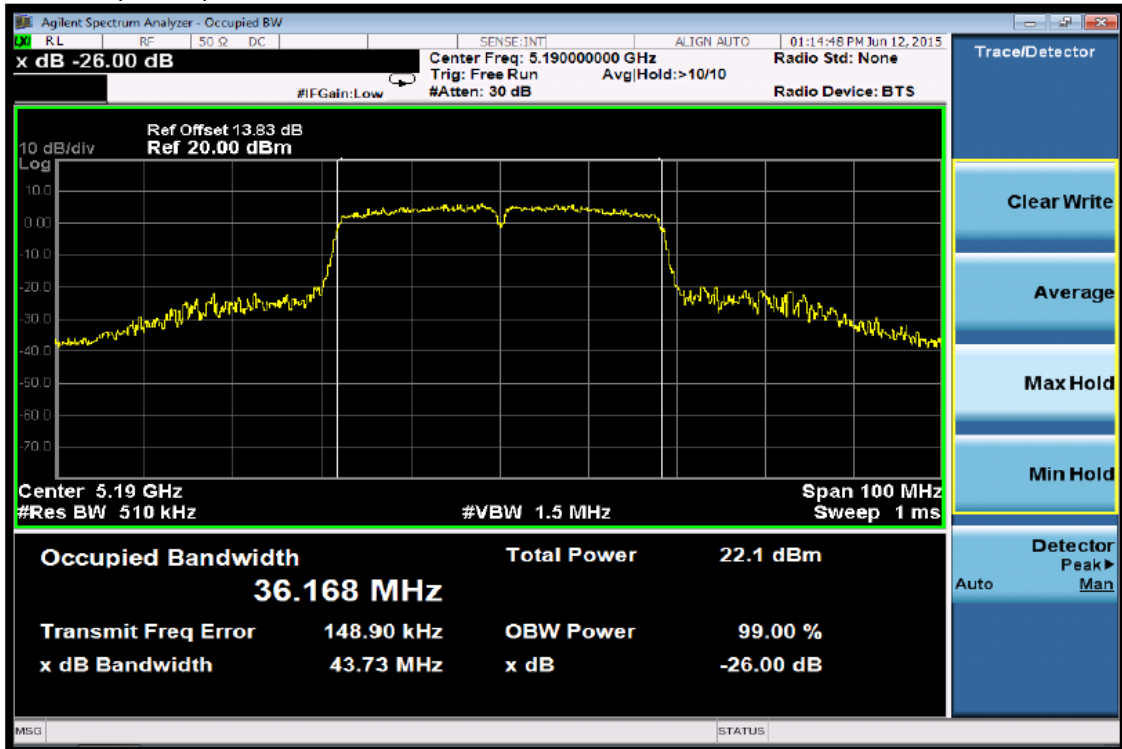

802.11n(HT40) 5230MHz

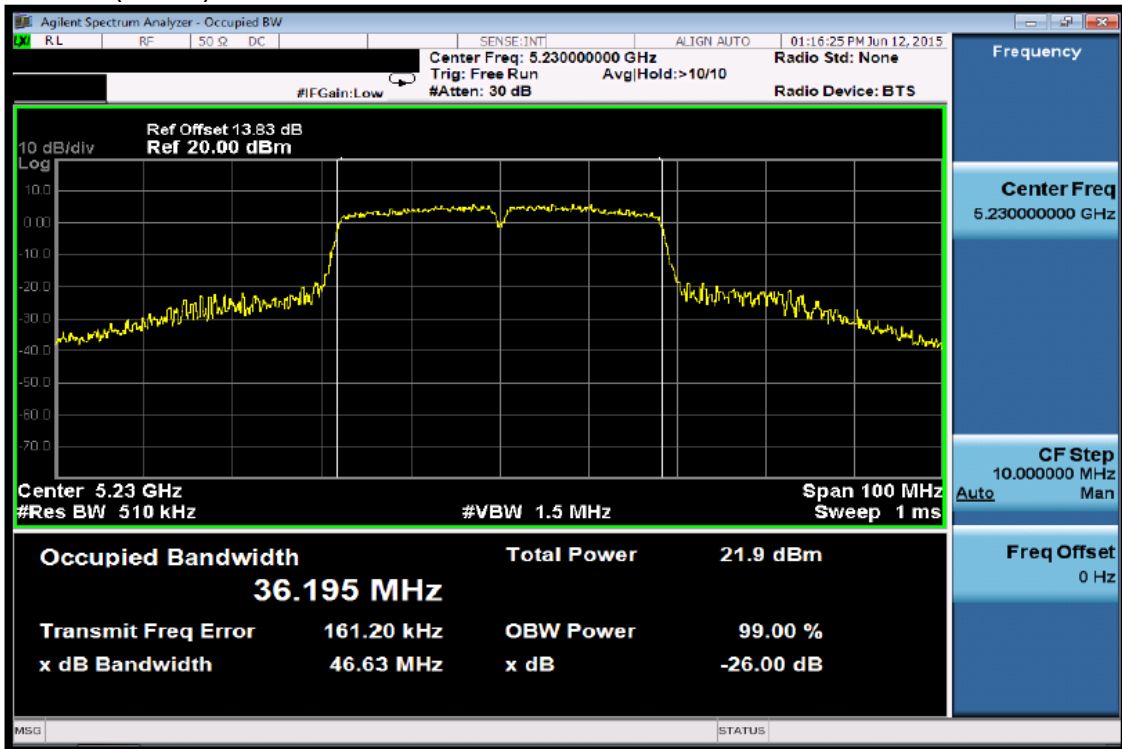



802.11ac 5210MHz

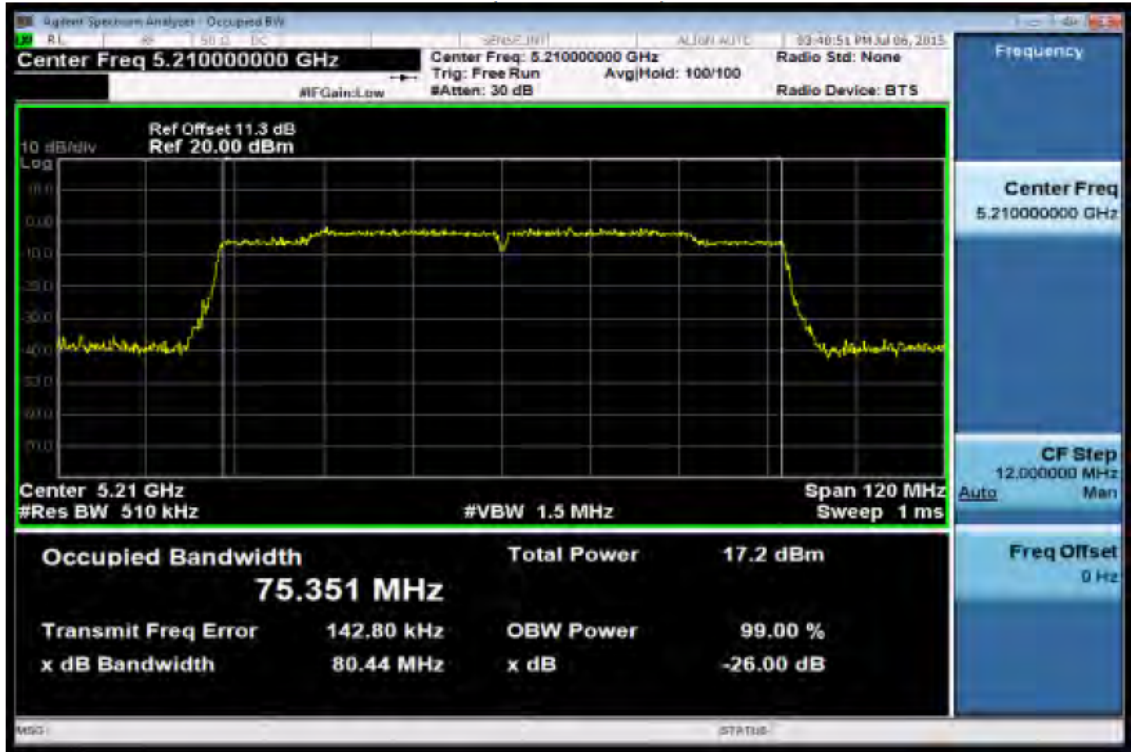



7. OUTPUT POWER TEST

7.1. Limits

Band 5.15-5.25GHz:

1. For mobile and portable client devices in the 5.15-5.25 GHz band, the maximum conducted output power over the frequency band of operation shall not exceed 250 mW provided the maximum antenna gain does not exceed 6 dBi

7.2. Test setup

2. The maximum average conducted output power can be measured using Method PM-G (Measurement using a gated RF average power meter):
3. Measurements may be performed using a wideband gated RF power meter provided that the gate parameters are adjusted such that the power is measured only when the EUT is transmitting at its maximum power control level. Since the measurement is made only during the ON time of the transmitter, no duty cycle correction factor is required.
 - a. The Transmitter output (antenna port) was connected to the power meter.
 - b. Turn on the EUT and power meter and then record the power value.
 - c. Repeat above procedures on all channels needed to be tested.

7.3. Test result

	Frequency (MHz)	Average Output Power(dBm)	FCC Limit (dBm)	Result
802.11a	5180	8.16	30.0	Pass
	5220	8.21	30.0	Pass
	5240	8.33	30.0	Pass
802.11n (HT20)	5180	7.05	30.0	Pass
	5220	7.11	30.0	Pass
	5240	7.04	30.0	Pass
802.11n (HT40)	5190	7.89	30.0	Pass
	5230	7.95	30.0	Pass
802.ac	5210	7.53	30.0	Pass



8. PEAK POWER SPECTRAL DENSITY TEST

8.1. Limits

Band 5.15-5.25GHz:

In addition, the maximum power spectral density shall not exceed 11 dBm in any 1 megahertz band.

8.2. Test setup

Methods refer to FCC KDB 789033

- 1) Create an average power spectrum for the EUT operating mode being tested by following the instructions in section E)2) for measuring maximum conducted output power using a spectrum analyzer or EMI receiver: select the appropriate test method (SA-3, or alternatives to each) and apply it up to, but not including, the step labeled, "Compute power...".
- 2) Use the peak search function on the instrument to find the peak of the spectrum.
- 3) The result is the PPSD.
- 4) The above procedures make use of 1 MHz resolution bandwidth to satisfy the 1 MHz Measurement bandwidth specified in the 15.407(a)(5). That rule section also permits use of resolution bandwidths less than 1 MHz "provided that the measured power is integrated to show the total power over the measurement bandwidth" (i.e., 1 MHz). If measurements are performed using a reduced resolution bandwidth and integrated over 1 MHz bandwidth

8.3. Test data

Test data as below

	Frequency (MHz)	POWER SPECTRAL DENSITY (dBm)	FCC Limit (dBm)	Result
802.11a	5180	-4.03	11.0	Pass
	5220	-3.20	11.0	Pass
	5240	-4.14	11.0	Pass
802.11n (HT20)	5180	-4.80	11.0	Pass
	5220	-5.04	11.0	Pass
	5240	-4.79	11.0	Pass
802.11n (HT40)	5190	-10.41	11.0	Pass
	5230	-7.75	11.0	Pass
802.11ac	5210	-6.67	11.0	Pass



802.11a 5180MHz

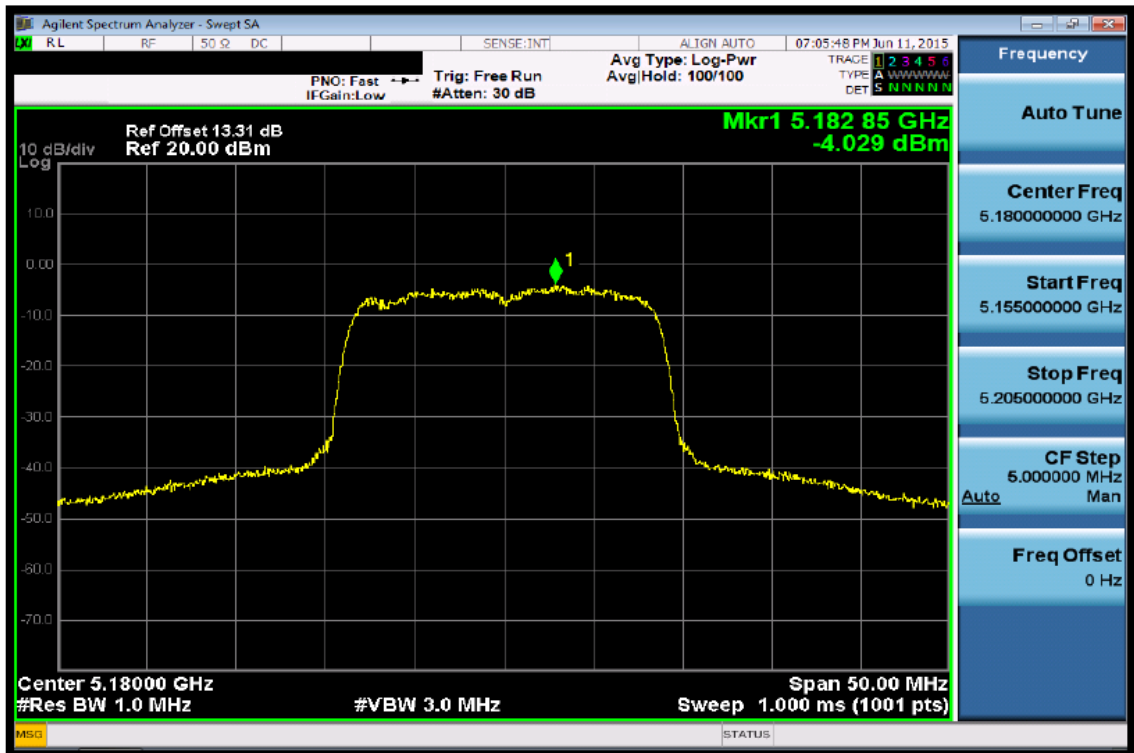

802.11a 5220MHz

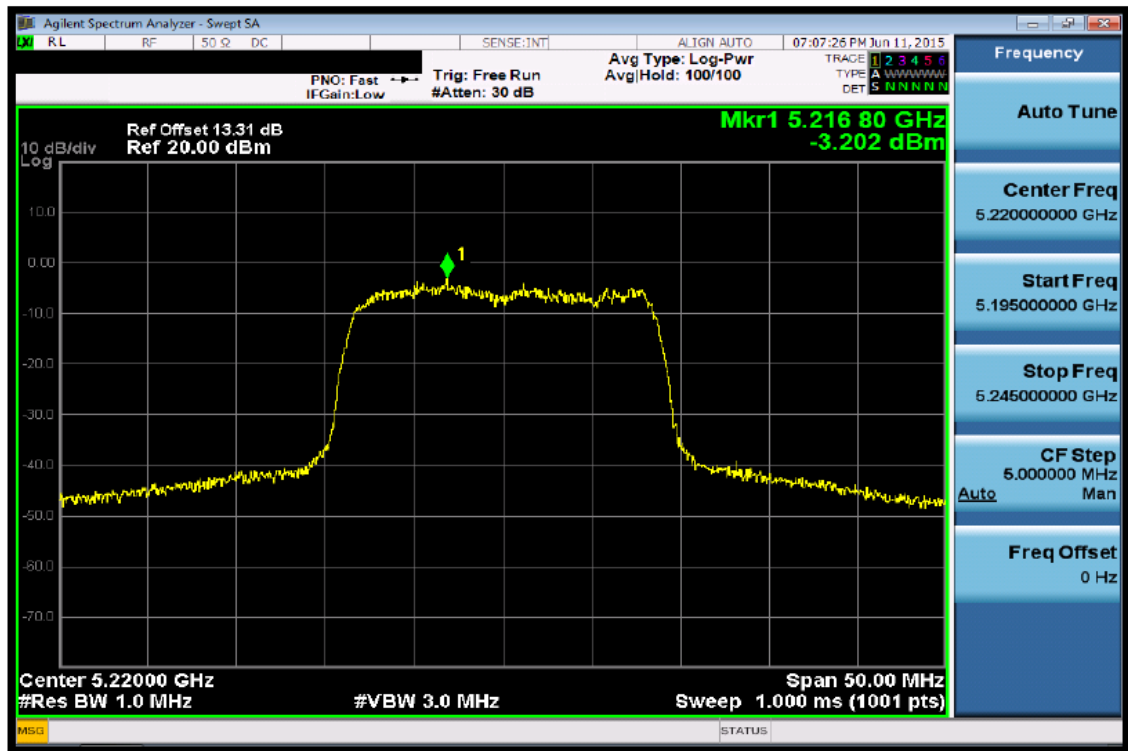



802.11a 5240MHz

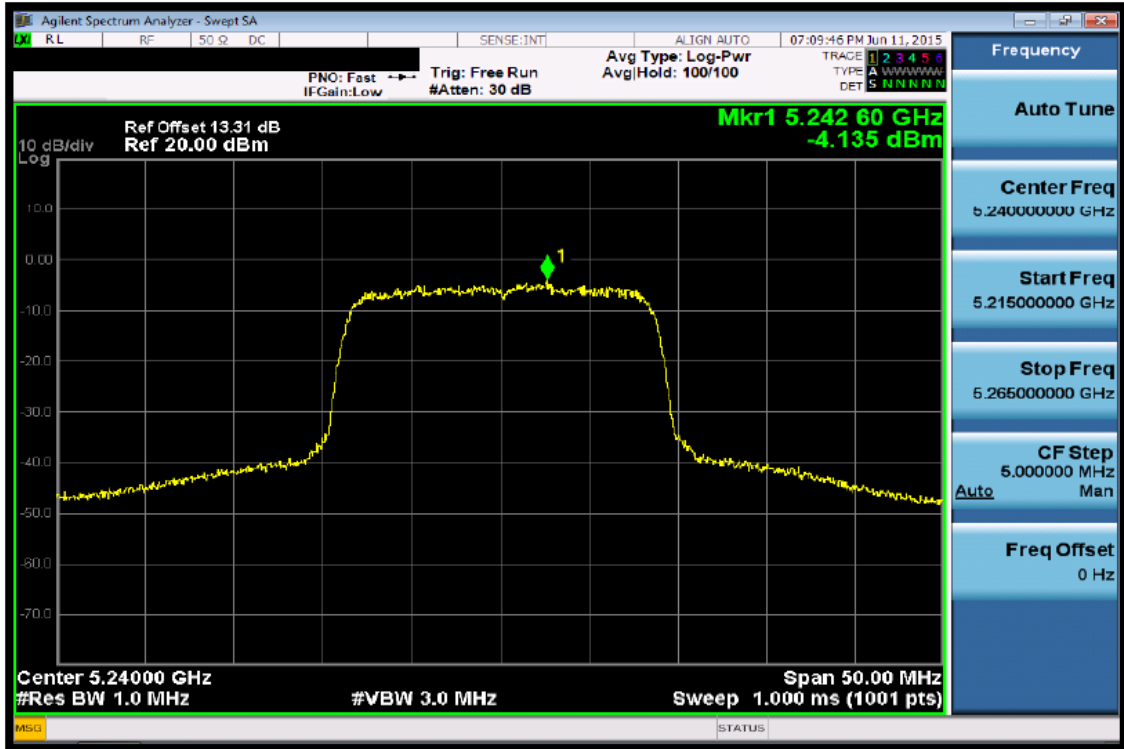

802.11n (HT20) 5180MHz

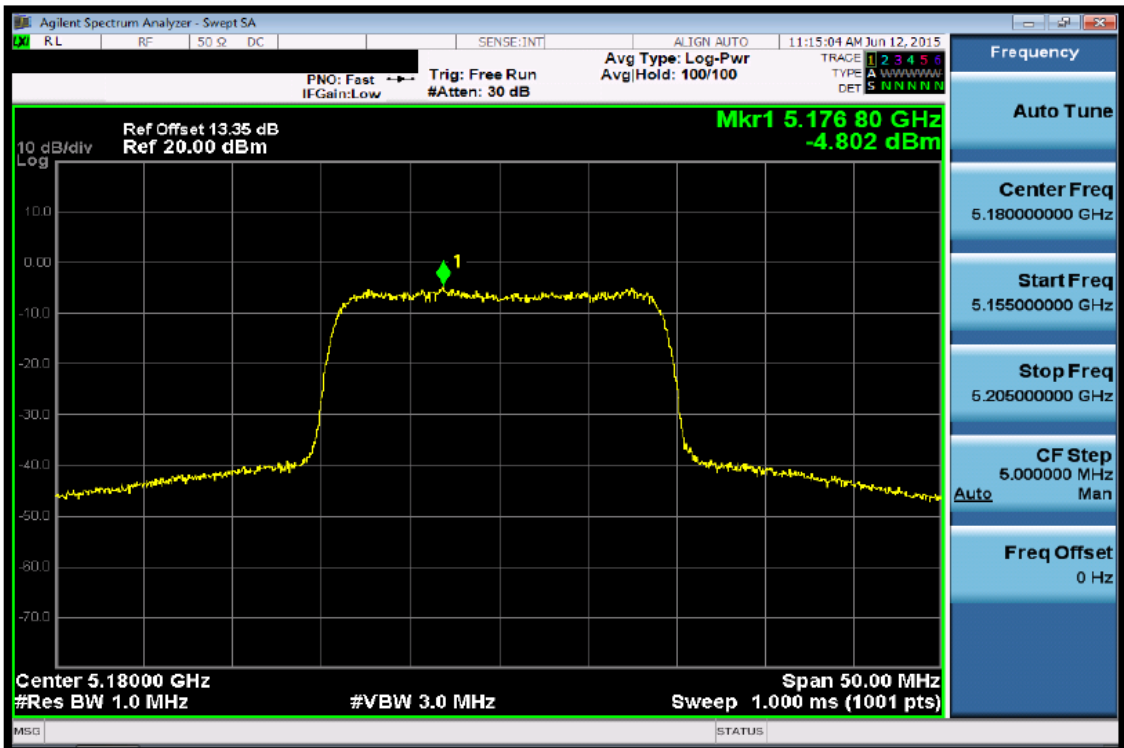



802.11n (HT20) 5220MHz

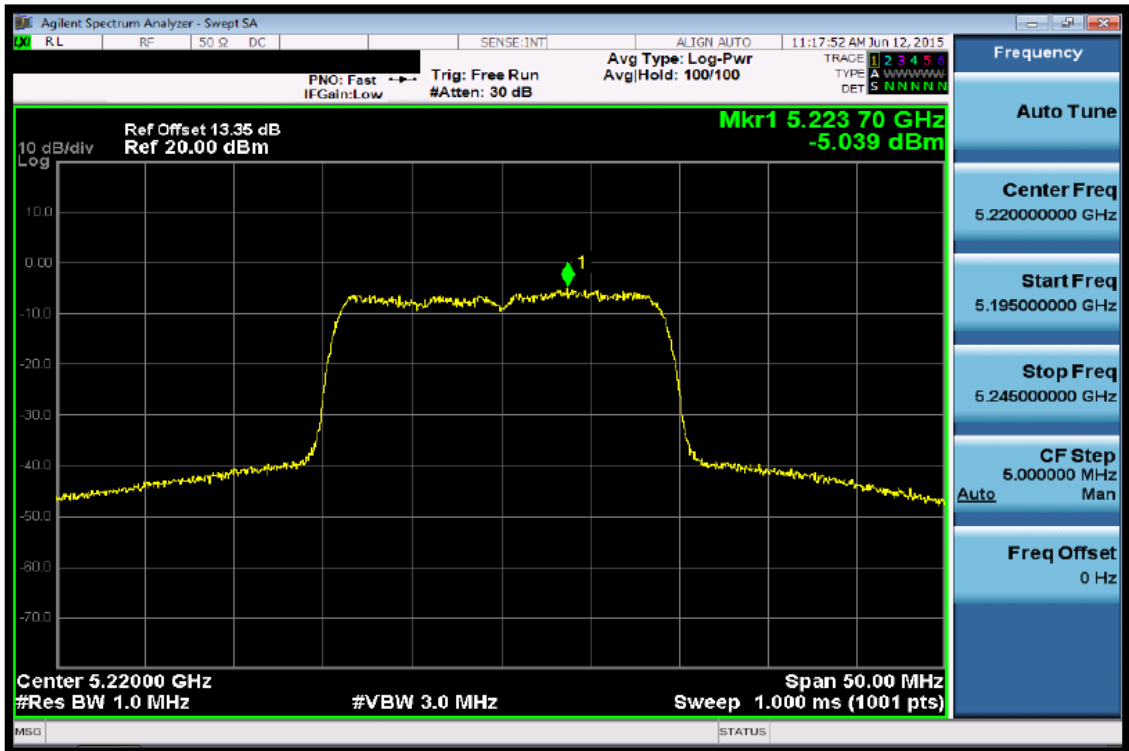

802.11n (HT20) 5240MHz





802.11 n (HT40) 5190MHz



802.11 n (HT40) 5230MHz





802.11 ac 5210MHz





9. DUTY CYCLE OF TEST SIGNAL

9.1. STANDARD REQUIREMENT

Pre-analysis Check: While conducting average power measurement, duty cycle of each mode shall be checked to ensure its duty cycle in order to compensate for the loss due to insufficient ratio of duty cycle.

All duty cycle is pre-scanned, and result as obtained below shows only the most representative ones where duty cycle is conducted as the given transmission with given virtual operation that expresses the percentage.

9.2. Formula:

$$\text{Duty Cycle} = \text{Ton} / (\text{Ton} + \text{Toff})$$

Measurement Procedure:

1. Set span = Zero
2. RBW = 8MHz
3. VBW = 8MHz,
4. Detector = Peak

Duty Cycle:

	Duty Cycle	Duty Fator(dB)
802.11a	88.87%	0.51
802.11n(HT20)	88.20%	0.55
802.11n(HT40)	78.91%	1.03
802.ac	93.8%	0.28

$$\text{Duty Cycle Factor: } 10 * \log (1/0.8887) = 0.51$$

$$\text{Duty Cycle Factor: } 10 * \log (1/0.882) = 0.55$$

$$\text{Duty Cycle Factor: } 10 * \log (1/0.7891) = 1.03$$

$$\text{Duty Cycle Factor: } 10 * \log (1/0.9380) = 0.28$$



DUTY CYCLE TEST SIGNAL Measurement Result
802.11 a

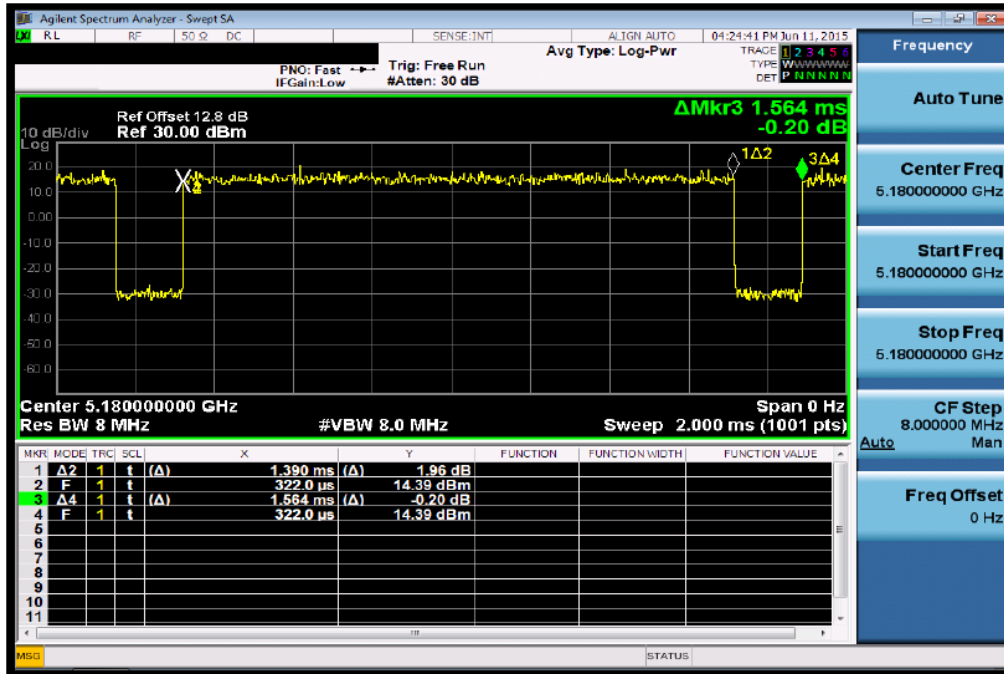

802.11n(HT20)

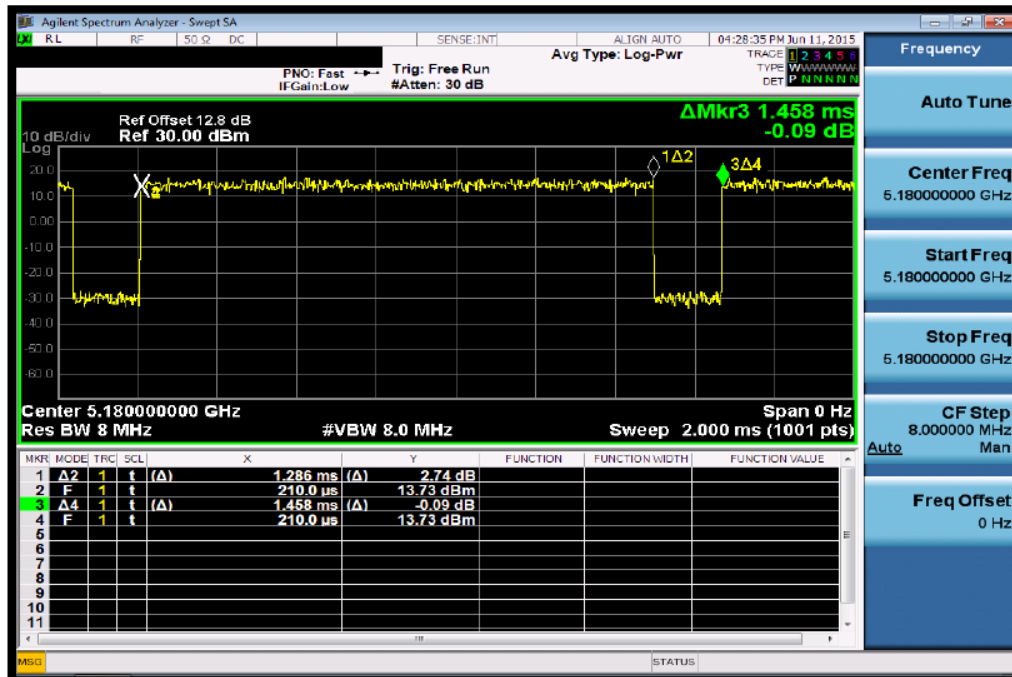



802.11n(HT40)

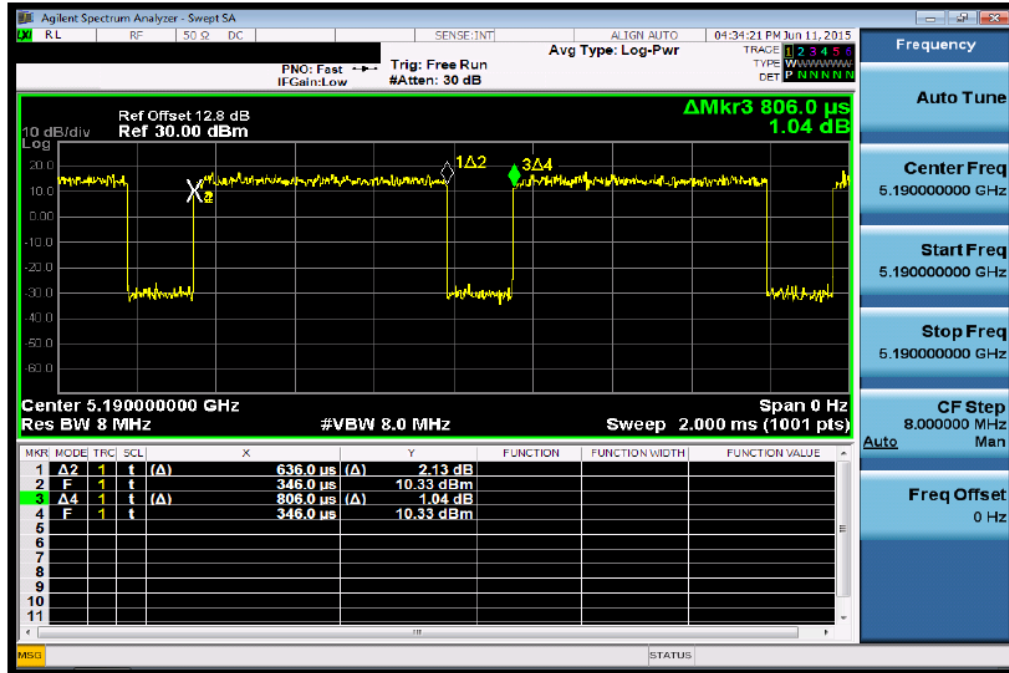

802.ac



10. PHOTOGRAPHS OF TEST SET-UP

Conducted Emission



Radiated Emission Test

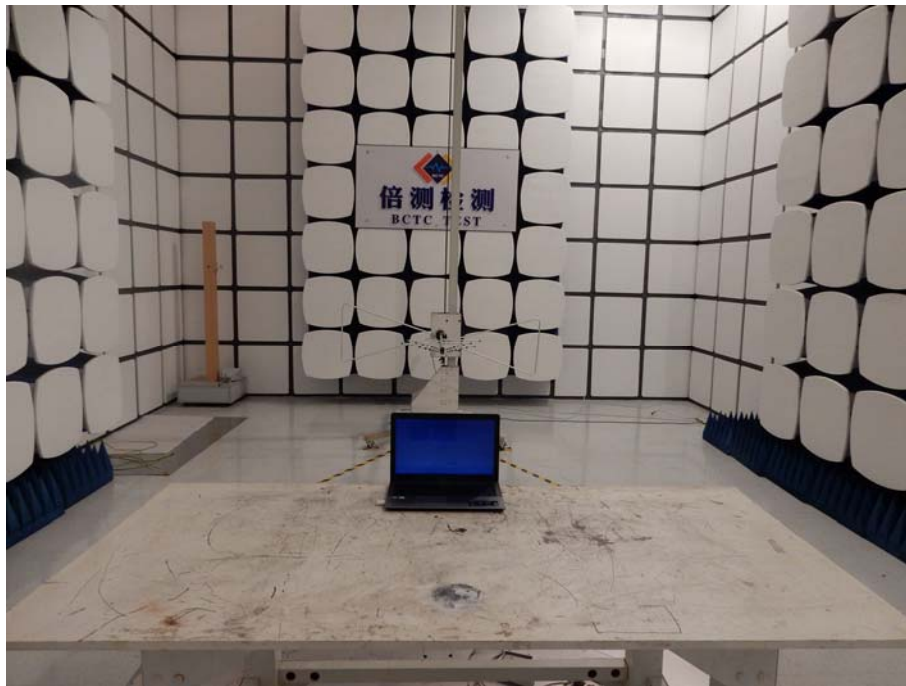

11. PHOTOGRAPHS OF THE EUT



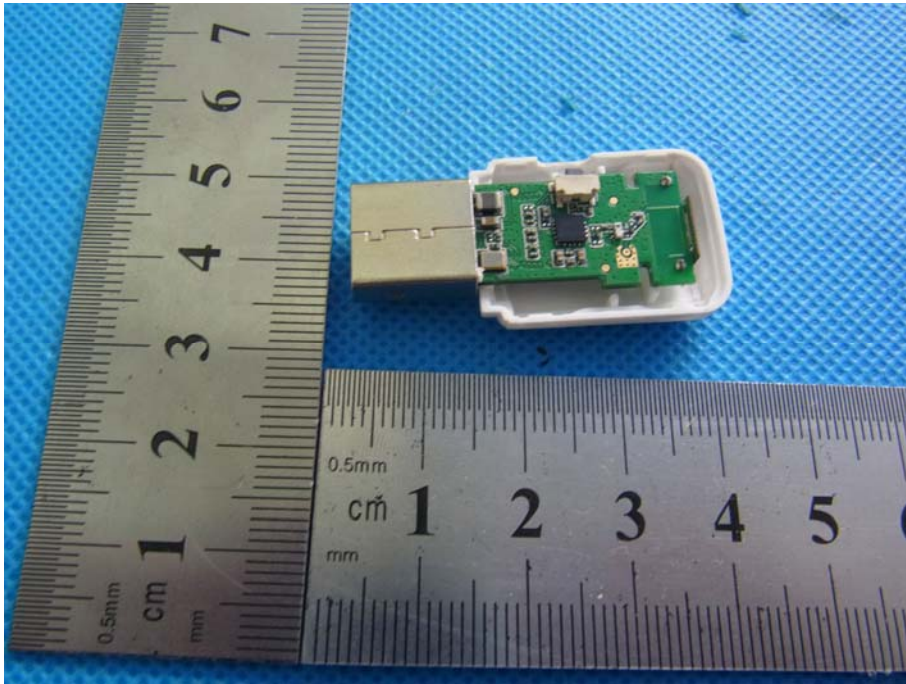

-----END-----