



# FCC Part 15C Test Report

## FCC ID: 2AFL4FX140AD

Product Name:	<b>11AC 433M DualBand Wireless USB Adapter</b>
Trademark:	<b>N/A</b>
Model Name :	<b>FX-WL140ACU-D</b>
Prepared For :	<b>Cerevo Inc.</b>
Address :	12F Fujisoft Akihabara Bldg.,3 Kandaneribei-cho, Chiyoda-ku,Tokyo,Japan
Prepared By :	<b>Shenzhen BCTC Technology Co., Ltd.</b>
Address :	No.101,Yousong Road,Longhua New District, Shenzhen,China
Test Date:	<b>Aug. 2 - Aug. 15, 2015</b>
Date of Report :	<b>Aug. 16, 2015</b>
Report No.:	<b>BCTC-15080191</b>



### TEST RESULT CERTIFICATION

**Applicant's name** ..... : **Cerevo Inc.**

Address ..... : 12F Fujisoft Akihabara Bldg.,3 Kandaneribei-cho,  
Chiyoda-ku,Tokyo,Japan

**Manufacture's Name**..... : **Liling FullRiver Electronics & Technology Ltd.**

Address ..... : FullRiver Industrial Area Economic, Development zone,  
liling city, Hunan Province, China

**Product description**

Product name ..... : 11AC 433M DualBand Wireless USB Adapter

Trade name ..... : N/A

Model and/or type reference : FX-WL140ACU-D

**Standards** ..... : FCC Part15.247

Test procedure ..... ANSI C63.10-2013

This device described above has been tested by BCTC, and the test results show that the equipment under test (EUT) is in compliance with the FCC requirements. And it is applicable only to the tested sample identified in the report.

This report shall not be reproduced except in full, without the written approval of BCTC, this document may be altered or revised by BCTC, personal only, and shall be noted in the revision of the document.

Testing Engineer : Eric Yang  
(Eric Yang)

Technical Manager : Sophie Lee  
(Sophia Lee)

Authorized Signatory : Casey Wang  
(Casey Wang)



**Table of Contents**

	<b>Page</b>
<b>1 . SUMMARY OF TEST RESULTS</b>	<b>5</b>
1.1 TEST FACILITY	6
1.2 MEASUREMENT UNCERTAINTY	6
<b>2 . GENERAL INFORMATION</b>	<b>7</b>
2.1 GENERAL DESCRIPTION OF EUT	7
2.2 DESCRIPTION OF TEST MODES	8
2.3 BLOCK DIGRAM SHOWING THE CONFIGURATION OF SYSTEM TESTED	9
2.4 DESCRIPTION OF SUPPORT UNITS(CONDUCTED MODE)	9
2.5 EQUIPMENTS LIST FOR ALL TEST ITEMS	10
<b>3 . EMC EMISSION TEST</b>	<b>11</b>
3.1 CONDUCTED EMISSION MEASUREMENT	11
3.1.1 POWER LINE CONDUCTED EMISSION LIMITS	11
3.1.2 TEST PROCEDURE	12
3.1.3 DEVIATION FROM TEST STANDARD	12
3.1.4 TEST SETUP	12
3.1.5 EUT OPERATING CONDITIONS	12
3.1.6 TEST RESULTS	13
3.2 RADIATED EMISSION MEASUREMENT	15
3.2.1 RADIATED EMISSION LIMITS	15
3.2.2 TEST PROCEDURE	16
3.2.3 DEVIATION FROM TEST STANDARD	16
3.2.4 TEST SETUP	17
3.2.5 EUT OPERATING CONDITIONS	18
3.2.6 TEST RESULTS (BETWEEN 9KHZ – 30 MHZ)	19
3.2.7 TEST RESULTS (BETWEEN 30MHZ – 1GHZ)	20
3.2.8 TEST RESULTS (ABOVE 1000 MHZ)	22
<b>4 . POWER SPECTRAL DENSITY TEST</b>	<b>28</b>
4.1 APPLIED PROCEDURES / LIMIT	28
4.1.1 TEST PROCEDURE	28
4.1.2 DEVIATION FROM STANDARD	28
4.1.3 TEST SETUP	28
4.1.4 EUT OPERATION CONDITIONS	28
4.1.5 TEST RESULTS	29



<b>Table of Contents</b>	<b>Page</b>
<b>5 . BANDWIDTH TEST</b>	<b>37</b>
<b>5.1 APPLIED PROCEDURES / LIMIT</b>	<b>37</b>
5.1.1 TEST PROCEDURE	37
5.1.2 DEVIATION FROM STANDARD	37
5.1.3 TEST SETUP	37
5.1.4 EUT OPERATION CONDITIONS	37
5.1.5 TEST RESULTS	38
<b>6 . PEAK OUTPUT POWER TEST</b>	<b>46</b>
<b>6.1 APPLIED PROCEDURES / LIMIT</b>	<b>46</b>
6.1.1 TEST PROCEDURE	46
6.1.2 DEVIATION FROM STANDARD	46
6.1.3 TEST SETUP	46
6.1.4 EUT OPERATION CONDITIONS	46
6.1.5 TEST RESULTS	47
<b>7 . 100 KHZ BANDWIDTH OF FREQUENCY BAND EDGE</b>	<b>48</b>
7.1 DEVIATION FROM STANDARD	48
7.2 TEST SETUP	49
7.3 EUT OPERATION CONDITIONS	49
7.4 TEST RESULTS	49
<b>8 . DUTY CYCLE OF TEST SIGNAL</b>	<b>54</b>
8.1 STANDARD REQUIREMENT	54
8.2 FORMULA:	54
<b>9.ANTENNA REQUIREMENT</b>	<b>57</b>
9.1 STANDARD REQUIREMENT	57
9.2 EUT ANTENNA	57
<b>10. EUT TEST PHOTO</b>	<b>58</b>
<b>11. EUT PHOTO</b>	<b>60</b>
<b>APPENDIX-PHOTOGRAPHS OF EUT CONSTRUCTIONAL DETAILS</b>	



## 1. SUMMARY OF TEST RESULTS

Test procedures according to the technical standards:

<b>FCC Part15 (15.247) , Subpart C</b>			
Standard Section	Test Item	Judgment	Remark
15.207	Conducted Emission	PASS	
15.247 (a)(2)	6dB Bandwidth	PASS	
15.247 (b)	Peak Output Power	PASS	
15.247 (c)	Radiated Spurious Emission	PASS	
15.247 (d)	Power Spectral Density	PASS	
15.205	Band Edge Emission	PASS	
15.203	Antenna Requirement	PASS	

**NOTE:**

(1) "N/A" denotes test is not applicable in this Test Report



## 1.1 TEST FACILITY

Shenzhen BCTC Technology Co., Ltd.

Add. : No.101,Yousong Road,Longhua New District, Shenzhen,China

FCC Registered No.: 187086

## 1.2 MEASUREMENT UNCERTAINTY

The reported uncertainty of measurement  $y \pm U$ , where expanded uncertainty  $U$  is based on a standard uncertainty multiplied by a coverage factor of  $k=2$ , providing a level of confidence of approximately **95** %.

No.	Item	Uncertainty
1	Conducted Emission Test	$\pm 1.38\text{dB}$
2	RF power,conducted	$\pm 0.16\text{dB}$
3	Spurious emissions,conducted	$\pm 0.21\text{dB}$
4	All emissions,radiated(<1G)	$\pm 4.68\text{dB}$
5	All emissions,radiated(>1G)	$\pm 4.89\text{dB}$
6	Temperature	$\pm 0.5^\circ\text{C}$
7	Humidity	$\pm 2\%$



## 2. GENERAL INFORMATION

### 2.1 GENERAL DESCRIPTION OF EUT

Equipment	11AC 433M DualBand Wireless USB Adapter	
Trade Name	N/A	
Model Name	FX-WL140ACU-D	
Model Difference	N/A	
Product Description	Operation Frequency:	802.11b/g/n20MHz:2412~2462 MHz 802.11n 40MHz:2422~2452 MHz 802.11ac :5150~5250MHz
	Modulation Type:	OFDM/DSSS
	Bit Rate of Transmitter	802.11b:11/5.5/2/1 Mbps 802.11g:54/48/36/24/18/12/9/6Mbps 802.11n Up to 433Mbps
	Number Of Channel	11 CH, Please see Note 2.
	Antenna Designation:	Please see Note 3.
	Antenna Gain (dBi)	0.5dbi
	Based on the application, features, or specification exhibited in User's Manual, the EUT is considered as an ITE/Computing Device. More details of EUT technical specification, please refer to the User's Manual.	
Channel List	Please refer to the Note 2.	
Power Rating	DC 5V from PC input AC 120V/60Hz	
Adapter	N/A	
Battery	N/A	
Connecting I/O Port(s)	Please refer to the User's Manual	

Note:

1. For a more detailed features description, please refer to the manufacturer's specifications or the User's Manual.

2.

Channel List for 802.11b/g/n(20)							
Channel	Frequency (MHz)	Channel	Frequency (MHz)	Channel	Frequency (MHz)	Channel	Frequency (MHz)
01	2412	04	2427	07	2442	10	2457
02	2417	05	2432	08	2447	11	2462
03	2422	06	2437	09	2452		



Channel List for 802.11n(40)							
Channel	Frequency (MHz)	Channel	Frequency (MHz)	Channel	Frequency (MHz)	Channel	Frequency (MHz)
03	2422	05	2432	07	2442	09	2452
04	2427	06	2437	08	2447		

3.

Table for Filed Antenna

Ant	Brand	Model Name	Antenna Type	Connector	Gain (dBi)	NOTE
A	N/A	--	Internal Antenna	N/A	0.5	Wifi Antenna

## 2.2 DESCRIPTION OF TEST MODES

To investigate the maximum EMI emission characteristics generates from EUT, the test system was pre-scanning tested base on the consideration of following EUT operation mode or test configuration mode which possible have effect on EMI emission level. Each of these EUT operation mode(s) or test configuration mode(s) mentioned above was evaluated respectively.

Pretest Mode	Description
Mode 1	802.11b CH1/ CH6/ CH11
Mode 2	802.11g CH1/ CH6/ CH11
Mode 3	802.11n20 CH1/ CH6/ CH11
Mode 4	802.11n40 CH3/ CH6/ CH9
Mode 5	Link Mode

For Conducted Emission	
Final Test Mode	Description
Mode 5	Link Mode

For Radiated Emission	
Final Test Mode	Description
Mode 1	802.11b CH1/ CH6/ CH11
Mode 2	802.11g CH1/ CH6/ CH11
Mode 3	802.11n20 CH1/ CH6/ CH11
Mode 4	802.11n40 CH3/ CH6/ CH9

Note:

- (1) The measurements are performed at the highest, middle, lowest available channels.
- (2) The measurements are performed at all Bit Rate of Transmitter, the worst data was reported





### 2.3 BLOCK DIGRAM SHOWING THE CONFIGURATION OF SYSTEM TESTED

Conducted Emission Test

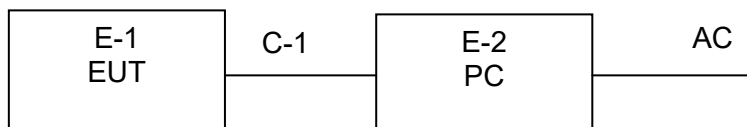

### 2.4 DESCRIPTION OF SUPPORT UNITS(CONDUCTED MODE)

The EUT has been tested as an independent unit together with other necessary accessories or support units. The following support units or accessories were used to form a representative test configuration during the tests.

Item	Equipment	Mfr/Brand	Model/Type No.	Series No.	Note
E-1	11AC 433M DualBand Wireless USB Adapter	N/A	FX-WL140ACU-D	N/A	EUT
E-2	PC	ASUS	50200AB	N/A	

Item	Shielded Type	Ferrite Core	Length	Note
C-1	NO	NO	2.5M	

Note:

- (1) The support equipment was authorized by Declaration of Confirmation.
- (2) For detachable type I/O cable should be specified the length in cm in 『Length』 column.



## 2.5 EQUIPMENTS LIST FOR ALL TEST ITEMS

### Conduction test equipment

Item	Kind of Equipment	Manufacturer	Type No.	Serial No.	Last calibration	Calibrated until	Calibration period
1	Test Receiver	R&S	ESCI	1166.5950K03-101165-ha	2015.07.06	2016.07.06	1 year
2	LISN	R&S	NSLK8126	8126466	2014.08.24	2015.08.23	1 year
3	LISN	R&S	NSLK8126	8126487	2014.08.24	2015.08.23	1 year
4	50Ω Coaxial Switch	Anritsu	MP59B	6200264417	2015.07.06	2016.07.06	1 year
5	RF cables	R&S	R204	R20X	2015.07.06	2016.07.06	1 year

### Radiation test, Band-edge test and 6db bandwidth test equipment

Item	Kind of equipment	Manufacturer	Type No.	Serial No.	Last calibration	Calibrated until	Calibration period
1	Spectrum Analyzer	Agilent	E4407B	MY45108040	2015.07.06	2016.07.06	1 year
2	Test Receiver	R&S	ESPI	101318	2015.07.06	2016.07.06	1 year
3	Bilog Antenna	R&S	VULB9168	VULB9168-438	2015.07.06	2016.07.06	1 year
4	50Ω Coaxial Switch	Anritsu	MP59B	6200264416	2015.07.06	2016.07.06	1 year
5	Spectrum Analyzer	ADVANTEST	R3132	150900201	2015.07.06	2016.07.06	1 year
6	Horn Antenna	R&S	HF906	10027	2015.07.06	2016.07.06	1 year
7	Horn Ant	Schwarzbeck	BBHA 9170	9170-181	2015.07.06	2016.07.06	1 year
8	Amplifier	R&S	BBV9743	9743-019	2014.12.22	2015.12.21	1 year
9	Loop Antenna	ARA	PLA-1030/B	1029	2015.07.06	2016.07.06	1 year
10	RF cables	R&S	R203	R20X	2015.07.06	2016.07.06	1 year
11	Antenna connector	Florida RFLabs	Lab-Fle	RF 01#	2015.07.06	2016.07.06	1 year



### 3. EMC EMISSION TEST

#### 3.1 CONDUCTED EMISSION MEASUREMENT

##### 3.1.1 POWER LINE CONDUCTED EMISSION Limits (Frequency Range 150KHz-30MHz)

FREQUENCY (MHz)	Class B (dBuV)		Standard
	Quasi-peak	Average	
0.15 -0.5	66 - 56 *	56 - 46 *	CISPR
0.50 -5.0	56.00	46.00	CISPR
5.0 -30.0	60.00	50.00	CISPR

0.15 -0.5	66 - 56 *	56 - 46 *	FCC
0.50 -5.0	56.00	46.00	FCC
5.0 -30.0	60.00	50.00	FCC

Note:

- (1) The tighter limit applies at the band edges.
- (2) The limit of " \* " marked band means the limitation decreases linearly with the logarithm of the frequency in the range.

The following table is the setting of the receiver

Receiver Parameters	Setting
Attenuation	10 dB
Start Frequency	0.15 MHz
Stop Frequency	30 MHz
IF Bandwidth	9 kHz

### 3.1.2 TEST PROCEDURE

- The EUT was placed 0.8 meters from the horizontal ground plane with EUT being connected to the power mains through a line impedance stabilization network (LISN). All other support equipments powered from additional LISN(s). The LISN provide 50 Ohm/ 50uH of coupling impedance for the measuring instrument.
- Interconnecting cables that hang closer than 40 cm to the ground plane shall be folded back and forth in the center forming a bundle 30 to 40 cm long.
- I/O cables that are not connected to a peripheral shall be bundled in the center. The end of the cable may be terminated, if required, using the correct terminating impedance. The overall length shall not exceed 1 m.
- LISN at least 80 cm from nearest part of EUT chassis.
- For the actual test configuration, please refer to the related Item –EUT Test Photos.

Note:

We pretest all voltage about AC 120V and AC 240V, the worst data recording in the report.

### 3.1.3 DEVIATION FROM TEST STANDARD

No deviation

### 3.1.4 TEST SETUP

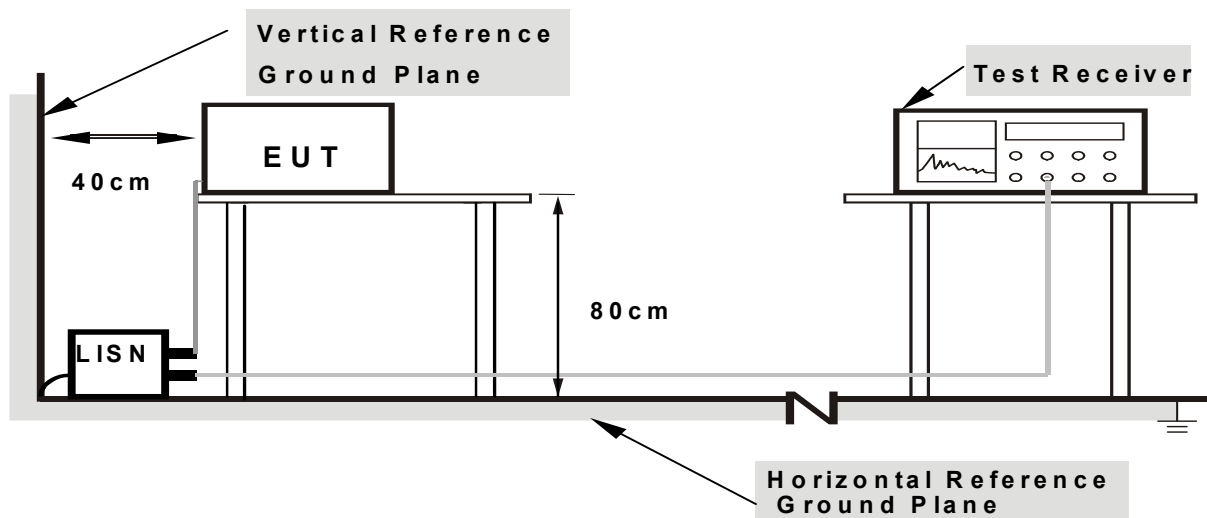

Note: 1.Support units were connected to second LISN .

2.Both of LISNs (AMN) are 80 cm from EUT and at least 80 from other units and other metal planes

### 3.1.5 EUT OPERATING CONDITIONS

The EUT was configured for testing in a typical fashion (as a customer would normally use it). The EUT has been programmed to continuously transmit during test. This operating condition was tested and used to collect the included data.



**3.1.6 TEST RESULTS**

EUT :	11AC 433M DualBand Wireless USB Adapter	Model Name. :	FX-WL140ACU-D
Temperature :	26°C	Relative Humidity :	54%
Pressure :	1010hPa	Phase :	L
Test Voltage :	DC 5V from PC input AC 120V/60Hz	Test Mode :	Mode 5

Frequency (MHz)	Meter Reading (dBμV)	Factor (dB)	Emission Level (dBμV)	Limits (dBμV)	Margin (dB)	Detector Type
0.4860	41.73	10.11	51.84	56.24	-4.40	QP
0.4860	28.39	10.11	38.50	46.24	-7.74	AVG
0.9580	38.83	10.16	48.99	56.00	-7.01	QP
0.9580	24.13	10.16	34.29	46.00	-11.71	AVG
1.5060	36.47	10.17	46.64	56.00	-9.36	QP
1.5060	23.07	10.17	33.24	46.00	-12.76	AVG
2.1660	35.58	10.18	45.76	56.00	-10.24	QP
2.1660	22.82	10.18	33.00	46.00	-13.00	AVG
3.2820	35.61	10.18	45.79	56.00	-10.21	QP
3.2820	20.73	10.18	30.91	46.00	-15.09	AVG
4.6420	32.59	10.15	42.74	56.00	-13.26	QP
4.6420	19.62	10.15	29.77	46.00	-16.23	AVG

**Remark:**

1. All readings are Quasi-Peak and Average values.
2. Factor = Insertion Loss + Cable Loss.

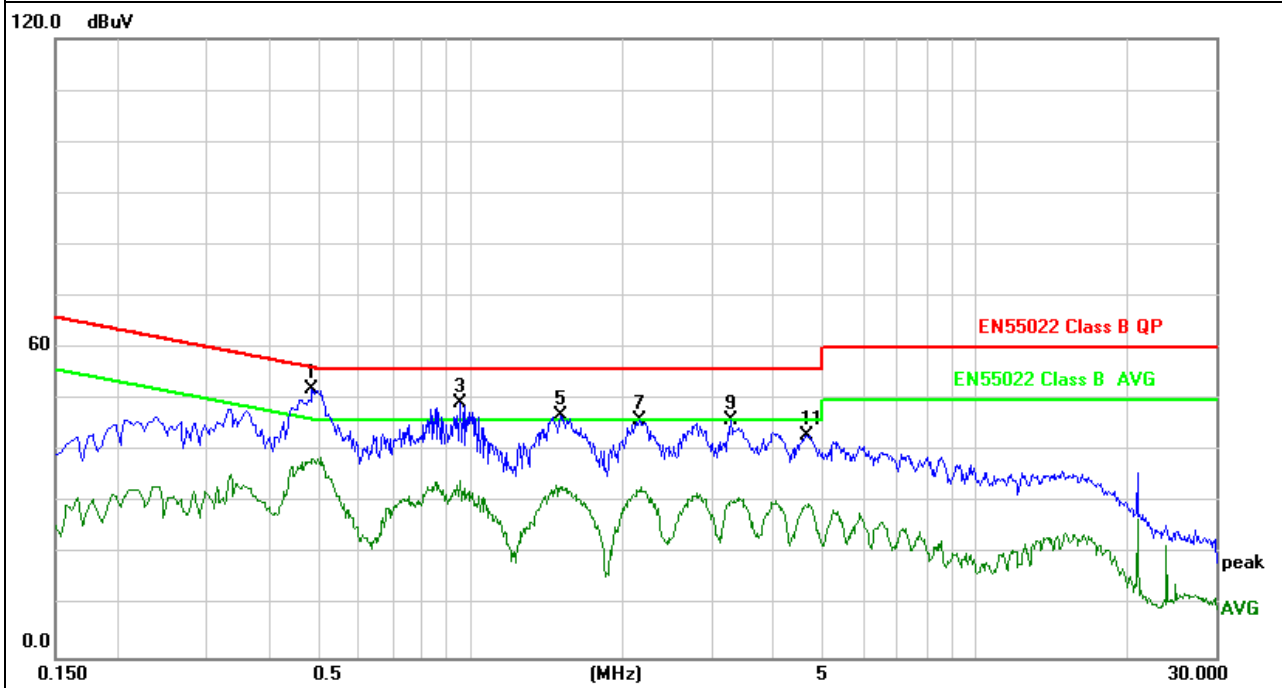



EUT :	11AC 433M DualBand Wireless USB Adapter	Model Name. :	FX-WL140ACU-D
Temperature :	26°C	Relative Humidity :	54%
Pressure :	1010hPa	Phase :	N
Test Voltage :	DC 5V from PC input AC 120V/60Hz	Test Mode :	Mode 5

Frequency (MHz)	Meter Reading (dBμV)	Factor (dB)	Emission Level (dBμV)	Limits (dBμV)	Margin (dB)	Detector Type
0.4900	38.01	10.11	48.12	56.17	-8.05	QP
0.4900	27.10	10.11	37.21	46.17	-8.96	AVG
0.9540	38.71	10.16	48.87	56.00	-7.13	QP
0.9540	21.82	10.16	31.98	46.00	-14.02	AVG
1.6660	32.94	10.18	43.12	56.00	-12.88	QP
1.6660	20.41	10.18	30.59	46.00	-15.41	AVG
2.2860	32.81	10.18	42.99	56.00	-13.01	QP
2.2860	19.90	10.18	30.08	46.00	-15.92	AVG
3.5740	31.29	10.17	41.46	56.00	-14.54	QP
3.5740	17.80	10.17	27.97	46.00	-18.03	AVG
4.7740	31.50	10.15	41.65	56.00	-14.35	QP
4.7740	17.07	10.15	27.22	46.00	-18.78	AVG

Remark:

1. All readings are Quasi-Peak and Average values.
2. Factor = Insertion Loss + Cable Loss.

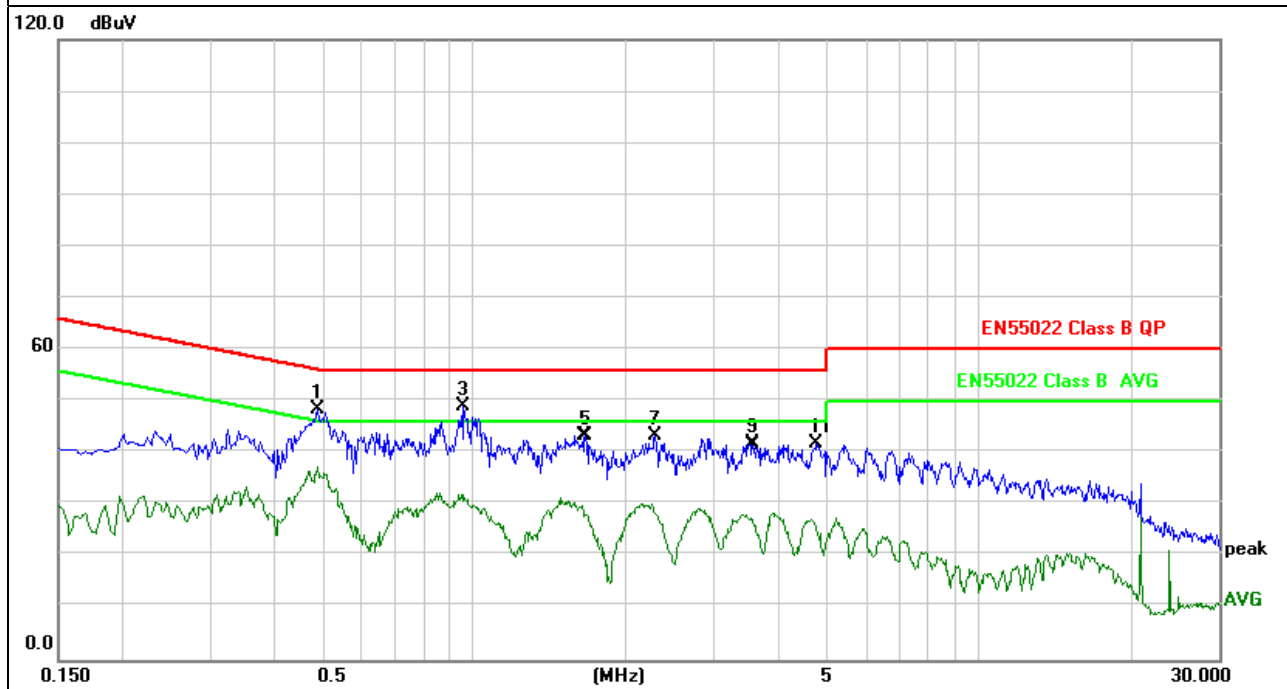



### 3.2 RADIATED EMISSION MEASUREMENT

#### 3.2.1 RADIATED EMISSION LIMITS (Frequency Range 9kHz-1000MHz)

20dBc in any 100 kHz bandwidth outside the operating frequency band. In case the emission fall within the restricted band specified on 15.205(a), then the 15.209(a) limit in the table below has to be followed.

Frequencies (MHz)	Field Strength (microrvolts/meter)	Measurement Distance (meters)
0.009~0.490	2400/F(KHz)	300
0.490~1.705	24000/F(KHz)	30
1.705~30.0	30	30
30~88	100	3
88~216	150	3
216~960	200	3
Above 960	500	3

#### LIMITS OF RADIATED EMISSION MEASUREMENT (Above 1000MHz)

FREQUENCY (MHz)	Class B (dBuV/m) (at 3M)	
	PEAK	AVERAGE
Above 1000	74	54

Notes:

- (1) The limit for radiated test was performed according to FCC PART 15C.
- (2) The tighter limit applies at the band edges.
- (3) Emission level (dBuV/m)=20log Emission level (uV/m).

Spectrum Parameter	Setting
Attenuation	Auto
Start Frequency	1000 MHz
Stop Frequency	10th carrier harmonic
RB / VB (emission in restricted band)	1 MHz / 1 MHz for Peak, 1 MHz / 10Hz for Average

Receiver Parameter	Setting
Attenuation	Auto
Start ~ Stop Frequency	9kHz~150kHz / RB 200Hz for QP
Start ~ Stop Frequency	150kHz~30MHz / RB 9kHz for QP
Start ~ Stop Frequency	30MHz~1000MHz / RB 120kHz for QP



### 3.2.2 TEST PROCEDURE

- a. The measuring distance of at 3 m shall be used for measurements at frequency up to 1GHz. For frequencies above 1GHz, any suitable measuring distance may be used.
- b. The EUT was placed on the top of a rotating table 0.8 meters above the ground at a 3 meter open area test site. The table was rotated 360 degrees to determine the position of the highest radiation.
- c. The height of the equipment or of the substitution antenna shall be 0.8 m; the height of the test antenna shall vary between 1 m to 4 m. Both horizontal and vertical polarizations of the antenna are set to make the measurement.
- d. The initial step in collecting conducted emission data is a spectrum analyzer peak detector mode pre-scanning the measurement frequency range. Significant peaks are then marked and then Quasi Peak detector mode re-measured.
- e. If the Peak Mode measured value compliance with and lower than Quasi Peak Mode Limit, the EUT shall be deemed to meet QP Limits and then no additional QP Mode measurement performed.
- f. For the actual test configuration, please refer to the related Item –EUT Test Photos.
- g. we pretest up to 10th harmonic. but only the worst data recording in the report.

Note:

Both horizontal and vertical antenna polarities were tested and performed pretest to three orthogonal axis. The worst case emissions were reported We pretest all voltage about AC 120V and AC 240V, the wrost data recording in the report.

### 3.2.3 DEVIATION FROM TEST STANDARD

No deviation



### 3.2.4 TEST SETUP

#### (A) Radiated Emission Test-Up Frequency Below 30MHz

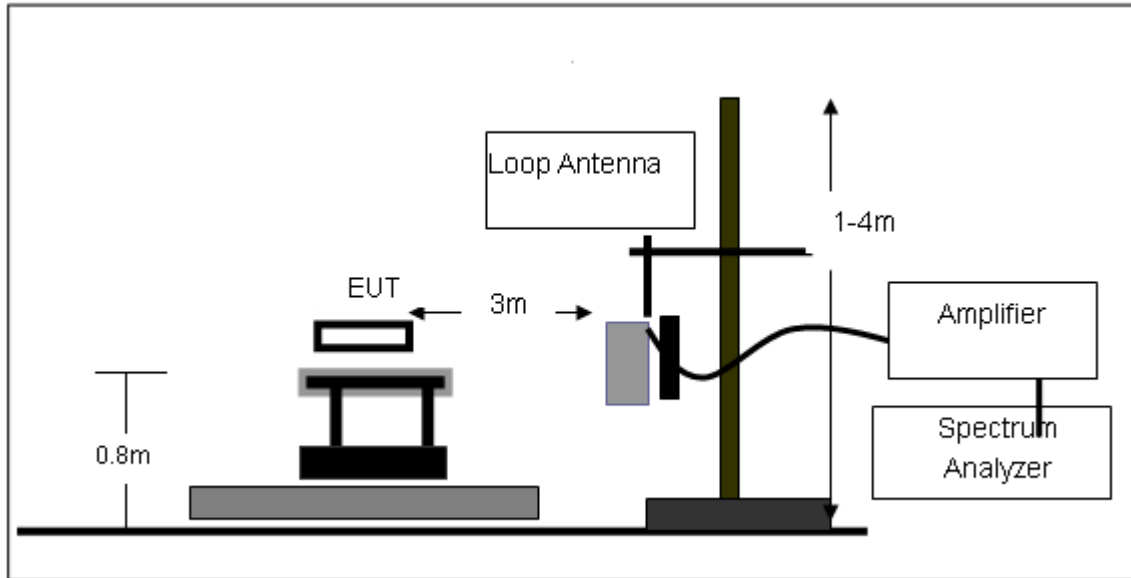

#### (B) Radiated Emission Test-Up Frequency 30MHz~1GHz

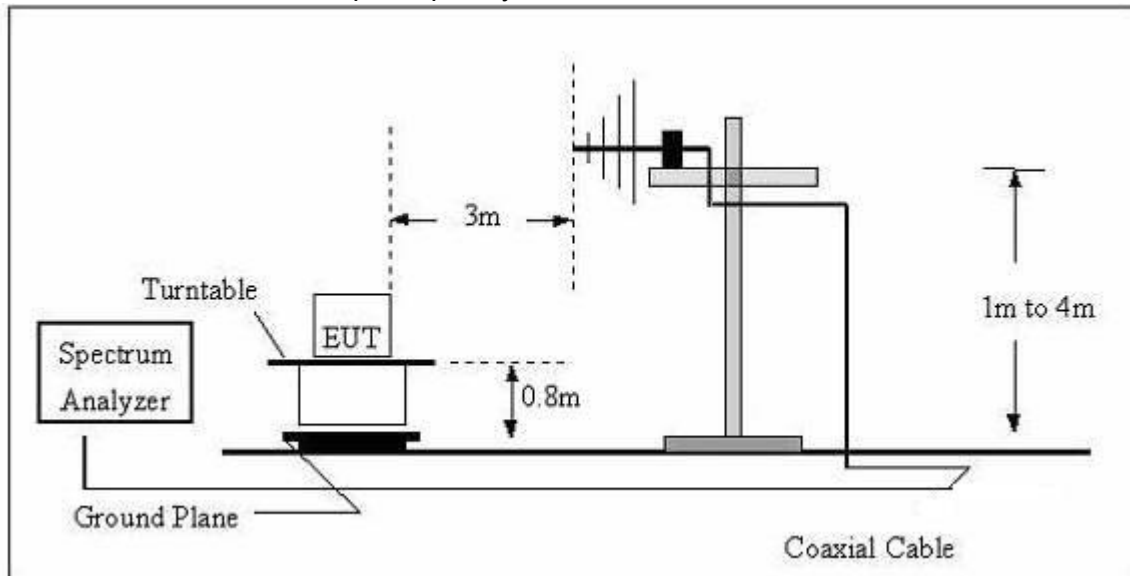

(C) Radiated Emission Test-Up Frequency Above 1GHz

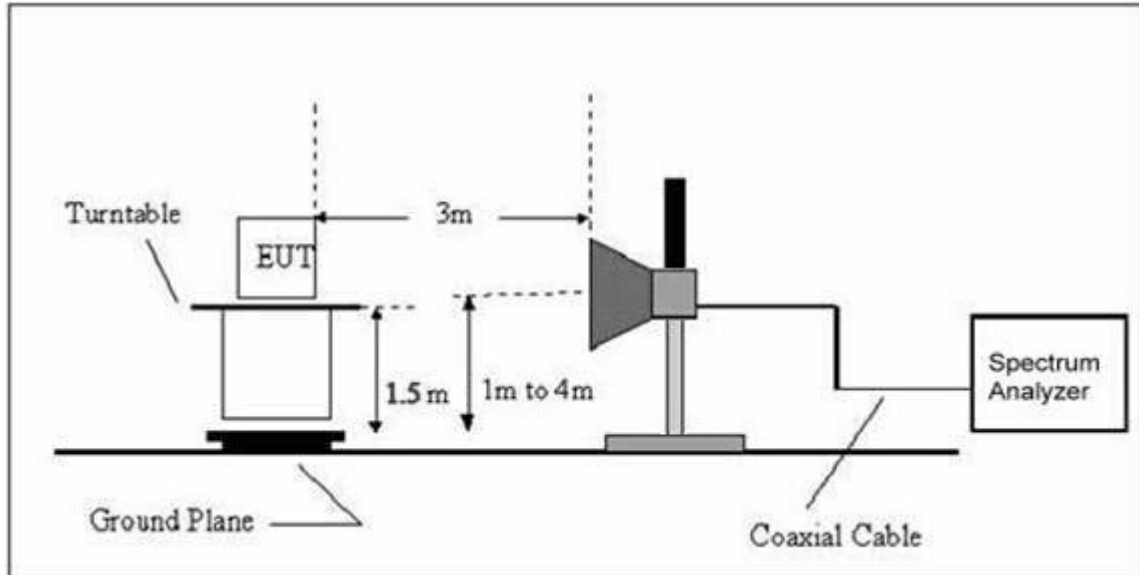

**3.2.5 EUT OPERATING CONDITIONS**

The EUT tested system was configured as the statements of 2.4 Unless otherwise a special operating condition is specified in the follows during the testing.

**3.2.6 TEST RESULTS (BETWEEN 9KHZ – 30 MHZ)**

EUT:	11AC 433M DualBand Wireless USB Adapter	Model Name. :	FX-WL140ACU-D
Temperature:	20°C	Relative Humidity:	48%
Pressure:	1010 hPa	Test Voltage :	DC 5V from PC input AC 120V/60Hz
Test Mode :	TX	Polarization :	--

Freq. (MHz)	Reading (dBuV/m)	Limit (dBuV/m)	Margin (dB)	State P/F
--	--	--	--	PASS
--	--	--	--	PASS

**NOTE:**

The amplitude of spurious emissions which are attenuated by more than 20dB below the permissible value has no need to be reported.

Distance extrapolation factor =  $40 \log(\text{specific distance}/\text{test distance})(\text{dB})$ ;

Limit line = specific limits(dBuv) + distance extrapolation factor.



**3.2.7 TEST RESULTS (BETWEEN 30MHZ – 1GHZ)**

EUT :	11AC 433M DualBand Wireless USB Adapter	Model Name :	FX-WL140ACU-D
Temperature :	26°C	Relative Humidity :	54%
Pressure :	1010 hPa	Polarization :	Horizontal
Test Voltage :	DC 5V from PC input AC 120V/60Hz		
Test Mode :	TX		

Frequency (MHz)	Meter Reading (dBμV)	Factor (dB)	Emission Level (dBμV/m)	Limits (dBμV/m)	Margin (dB)	Detector Type
180.0165	44.93	-14.34	30.59	43.50	-12.91	QP
190.4050	46.64	-15.61	31.03	43.50	-12.47	QP
228.4904	42.53	-15.14	27.39	46.00	-18.61	QP
419.1081	42.69	-9.76	32.93	46.00	-13.07	QP
647.3856	38.38	-5.12	33.26	46.00	-12.74	QP
687.1507	38.58	-4.59	33.99	46.00	-12.01	QP

Remark:  
 Factor = Antenna Factor + Cable Loss – Pre-amplifier.  
 All interfaces was connected, and BT TX mode was link.

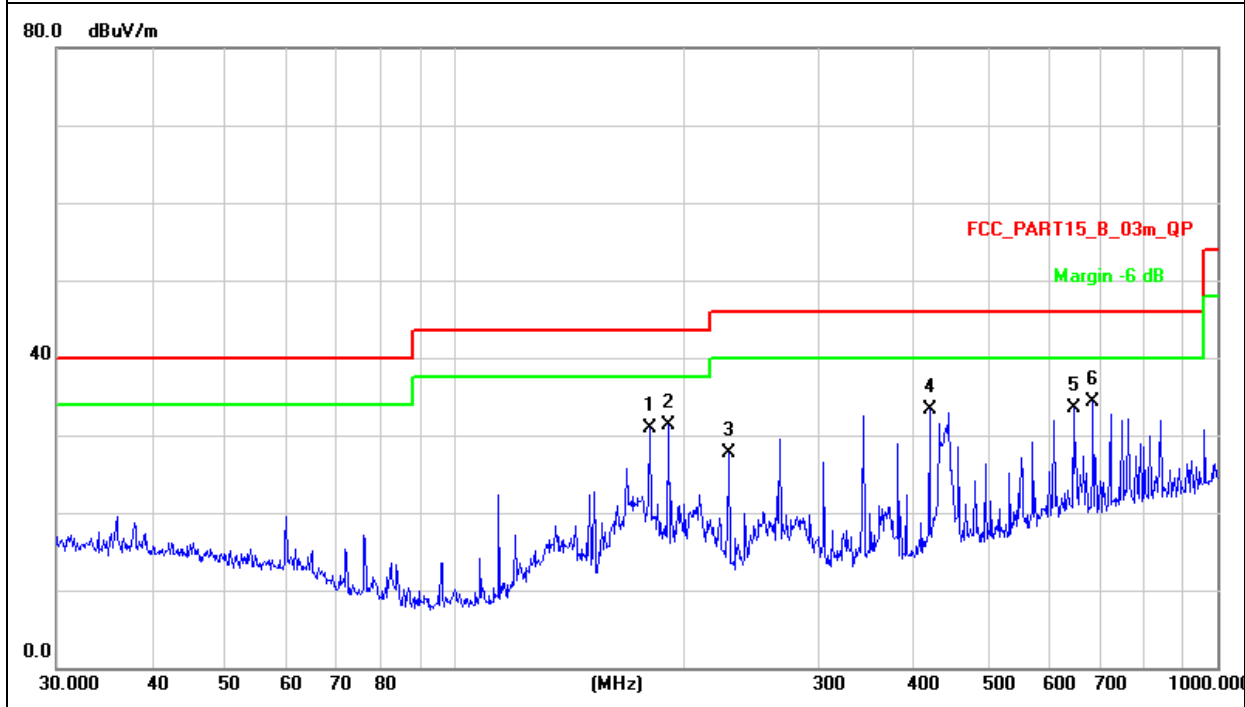



EUT :	11AC 433M DualBand Wireless USB Adapter	Model Name :	FX-WL140ACU-D
Temperature :	26°C	Relative Humidity :	54%
Pressure :	1010 hPa	Polarization :	Vertical
Test Voltage :	DC 5V from PC input AC 120V/60Hz		
Test Mode :	TX		

Frequency (MHz)	Meter Reading (dBμV)	Factor (dB)	Emission Level (dBμV/m)	Limits (dBμV/m)	Margin (dB)	Detector Type
125.0066	52.85	-14.41	38.44	43.50	-5.06	QP
170.1947	46.97	-13.47	33.50	43.50	-10.00	QP
297.2241	51.12	-12.66	38.46	46.00	-7.54	QP
313.2760	48.34	-12.23	36.11	46.00	-9.89	QP
375.9384	48.24	-10.77	37.47	46.00	-8.53	QP
625.0779	45.06	-5.52	39.54	46.00	-6.46	QP

Remark:  
 Factor = Antenna Factor + Cable Loss – Pre-amplifier.  
 All interfaces was connected, and BT TX mode was link.

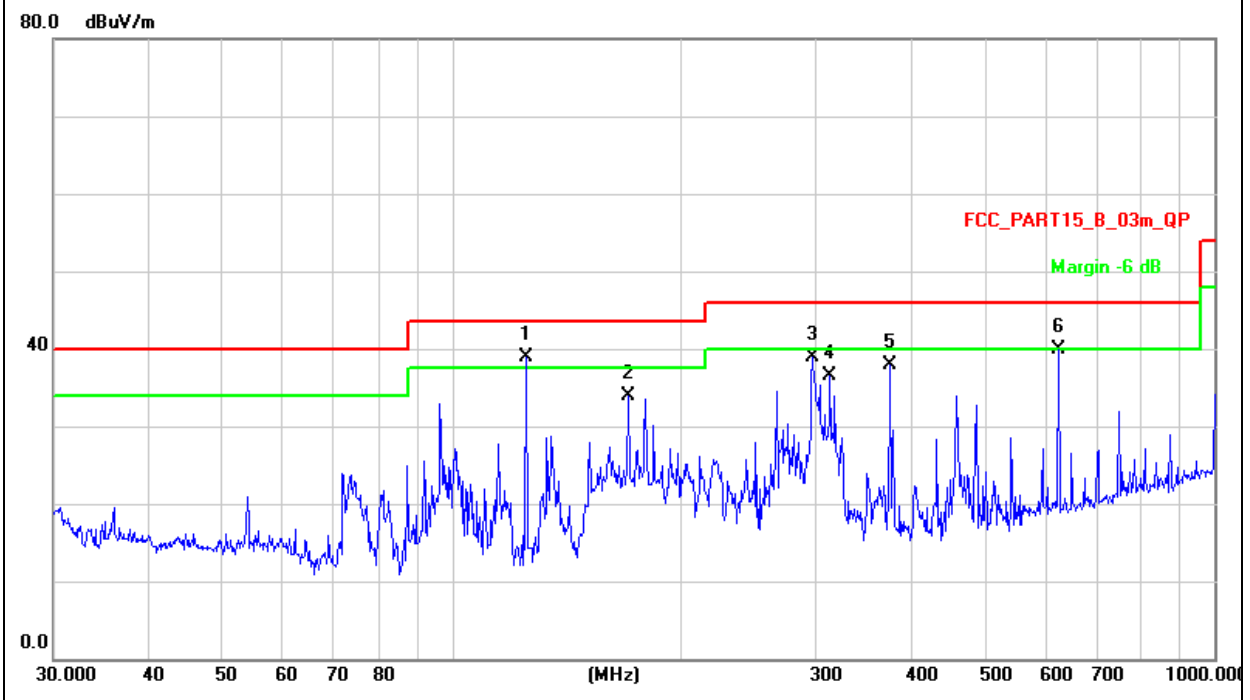



**3.2.8 TEST RESULTS (ABOVE 1000 MHZ)**

**802.11b**

Normal Voltage

Polar (H/V)	Frequency	Meter Reading	Factor	Emission Level	Limits	Margin	Detector Type
	(MHz)	(dBuV)	(dB)	(dBuV/m)	(dBuV/m)	(dB)	
<b>operation frequency:2412</b>							
V	4824.635	67.53	-3.6	63.93	74	-10.07	Pk
V	4824.635	46.46	-3.6	42.86	54	-11.14	AV
H	4825.251	66.62	-3.58	63.04	74	-10.96	Pk
H	4825.251	43.74	-3.58	40.16	54	-13.84	AV

**Remark:**

Absolute Level= ReadingLevel+ Factor, Margin= Limit- Absolute Level

**802.11b**

Normal Voltage

Polar (H/V)	Frequency	Meter Reading	Factor	Emission Level	Limits	Margin	Detector Type
	(MHz)	(dBuV)	(dB)	(dBuV/m)	(dBuV/m)	(dB)	
<b>operation frequency:2437</b>							
V	4874.436	65.25	-3.64	61.61	74	-12.39	Pk
V	4874.436	42.62	-3.64	38.98	54	-15.02	AV
H	4875.083	64.33	-3.64	60.69	74	-13.31	Pk
H	4875.083	41.22	-3.64	37.58	54	-16.42	AV

**Remark:**

Absolute Level= ReadingLevel+ Factor, Margin= Limit- Absolute Level

**802.11b**

Normal Voltage

Polar (H/V)	Frequency	Meter Reading	Factor	Emission Level	Limits	Margin	Detector Type
	(MHz)	(dBuV)	(dB)	(dBuV/m)	(dBuV/m)	(dB)	
<b>operation frequency:2462</b>							
V	4925.125	56.36	-3.64	52.72	74	-21.28	pk
H	4923.653	55.12	-3.66	51.46	74	-22.18	pk

**Remark:**

Absolute Level= ReadingLevel+ Factor, Margin= Limit- Absolute Level



**802.11g**

Normal Voltage

Polar (H/V)	Frequency	Meter Reading	Factor	Emission Level	Limits	Margin	Detector Type
	(MHz)	(dBuV)	(dB)	(dBuV/m)	(dBuV/m)	(dB)	
<b>operation frequency:2412</b>							
V	4823.824	62.48	-3.6	58.88	74	-15.12	Pk
V	4823.824	40.52	-3.6	36.92	54	-17.08	AV
H	4824.223	63.13	-3.6	59.53	74	-14.47	Pk
H	4824.223	41.92	-3.6	38.32	54	-15.68	AV
<b>Remark:</b>							
Absolute Level= ReadingLevel+ Factor, Margin= Limit- Absolute Level							

**802.11g**

Normal Voltage

Polar (H/V)	Frequency	Meter Reading	Factor	Emission Level	Limits	Margin	Detector Type
	(MHz)	(dBuV)	(dB)	(dBuV/m)	(dBuV/m)	(dB)	
<b>operation frequency:2437</b>							
V	4873.692	63.08	-3.63	59.45	74	-14.55	Pk
V	4873.692	41.15	-3.63	37.52	54	-16.48	AV
H	4874.51	60.39	-3.64	56.75	74	-17.25	Pk
H	4874.51	40.74	-3.64	37.1	54	-16.9	AV
<b>Remark:</b>							
Absolute Level= ReadingLevel+ Factor, Margin= Limit- Absolute Level							

**802.11g**

Normal Voltage

Polar (H/V)	Frequency	Meter Reading	Factor	Emission Level	Limits	Margin	Detector Type
	(MHz)	(dBuV)	(dB)	(dBuV/m)	(dBuV/m)	(dB)	
<b>operation frequency:2462</b>							
V	4924.395	55.12	-3.6	51.52	74	-22.48	pk
H	4923.987	56.01	-3.66	52.35	74	-22.18	pk
<b>Remark:</b>							
Absolute Level= ReadingLevel+ Factor, Margin= Limit- Absolute Level							



**802.11n(20MHz)**

Normal Voltage

Polar (H/V)	Frequency	Meter Reading	Factor	Emission Level	Limits	Margin	Detector Type
	(MHz)	(dBuV)	(dB)	(dBuV/m)	(dBuV/m)	(dB)	
<b>operation frequency:2412</b>							
V	4825.105	62.09	-3.58	58.51	74	-15.49	Pk
V	4825.105	41.89	-3.58	38.31	54	-15.69	AV
H	4824.426	61.18	-3.6	57.58	74	-16.42	Pk
H	4824.426	39.39	-3.6	35.79	54	-18.21	AV
<b>Remark:</b>							
Absolute Level= ReadingLevel+ Factor, Margin= Limit- Absolute Level							

**802.11n(20MHz)**

Normal Voltage

Polar (H/V)	Frequency	Meter Reading	Factor	Emission Level	Limits	Margin	Detector Type
	(MHz)	(dBuV)	(dB)	(dBuV/m)	(dBuV/m)	(dB)	
<b>operation frequency:2437</b>							
V	4875.522	63.08	-3.63	59.45	74	-14.55	Pk
V	4875.522	41.15	-3.63	37.52	54	-16.48	AV
H	4873.936	60.39	-3.64	56.75	74	-17.25	Pk
H	4873.936	40.74	-3.64	37.1	54	-16.9	AV
<b>Remark:</b>							
Absolute Level= ReadingLevel+ Factor, Margin= Limit- Absolute Level							

**802.11n(20MHz)**

Normal Voltage

Polar (H/V)	Frequency	Meter Reading	Factor	Emission Level	Limits	Margin	Detector Type
	(MHz)	(dBuV)	(dB)	(dBuV/m)	(dBuV/m)	(dB)	
<b>operation frequency:2462</b>							
V	4923.918	59.58	-3.64	55.94	74	-18.06	pk
V	4923.918	37.11	-3.64	33.47	54	-20.53	AV
H	4925.234	55.83	-3.66	52.17	74	-21.83	pk
<b>Remark:</b>							
Absolute Level= ReadingLevel+ Factor, Margin= Limit- Absolute Level							





**802.11n(40MHz)**

Normal Voltage

Polar (H/V)	Frequency	Meter Reading	Factor	Emission Level	Limits	Margin	Detector Type
	(MHz)	(dBuV)	(dB)	(dBuV/m)	(dBuV/m)	(dB)	
<b>operation frequency:2422</b>							
V	4844.105	61.62	-3.62	58.00	74	-16.00	Pk
V	4844.105	41.57	-3.62	37.95	54	-16.05	AV
H	4844.426	60.72	-3.76	56.96	74	-17.04	Pk
H	4844.426	39.09	-3.76	35.33	54	-18.67	AV
<b>Remark:</b>							
Absolute Level= ReadingLevel+ Factor, Margin= Limit- Absolute Level							

**802.11n(40MHz)**

Normal Voltage

Polar (H/V)	Frequency	Meter Reading	Factor	Emission Level	Limits	Margin	Detector Type
	(MHz)	(dBuV)	(dB)	(dBuV/m)	(dBuV/m)	(dB)	
<b>operation frequency:2437</b>							
V	4874.522	62.60	-3.87	58.73	74	-15.27	Pk
V	4874.522	40.84	-3.87	36.97	54	-17.03	AV
H	4874.936	59.93	-3.91	56.02	74	-17.98	Pk
H	4874.936	40.43	-3.91	36.52	54	-17.48	AV
<b>Remark:</b>							
Absolute Level= ReadingLevel+ Factor, Margin= Limit- Absolute Level							

**802.11n(40MHz)**

Normal Voltage

Polar (H/V)	Frequency	Meter Reading	Factor	Emission Level	Limits	Margin	Detector Type
	(MHz)	(dBuV)	(dB)	(dBuV/m)	(dBuV/m)	(dB)	
<b>operation frequency:2452</b>							
V	4923.918	59.13	-3.29	55.84	74	-18.16	pk
V	4923.918	36.83	-3.29	33.54	54	-20.46	AV
H	4925.234	55.41	-3.34	52.07	74	-21.93	pk
<b>Remark:</b>							
Absolute Level= ReadingLevel+ Factor, Margin= Limit- Absolute Level							



For conducted:

We pretest all mode, only 802.11b was worst and the data recording in the report.

802.11b low channel

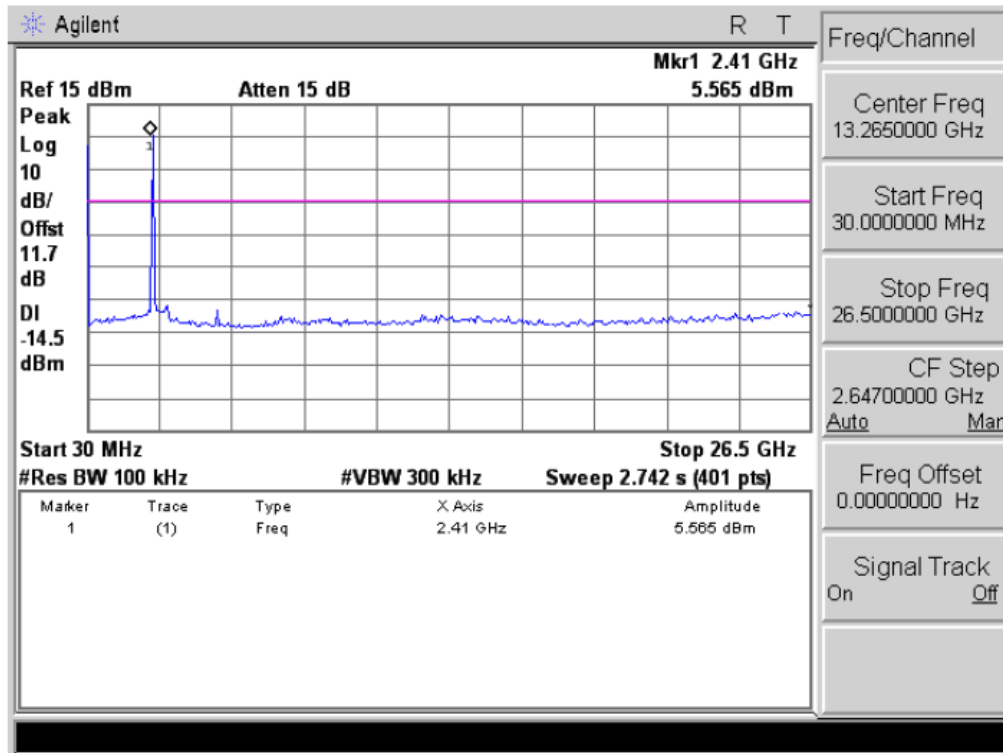



802.11b middle channel

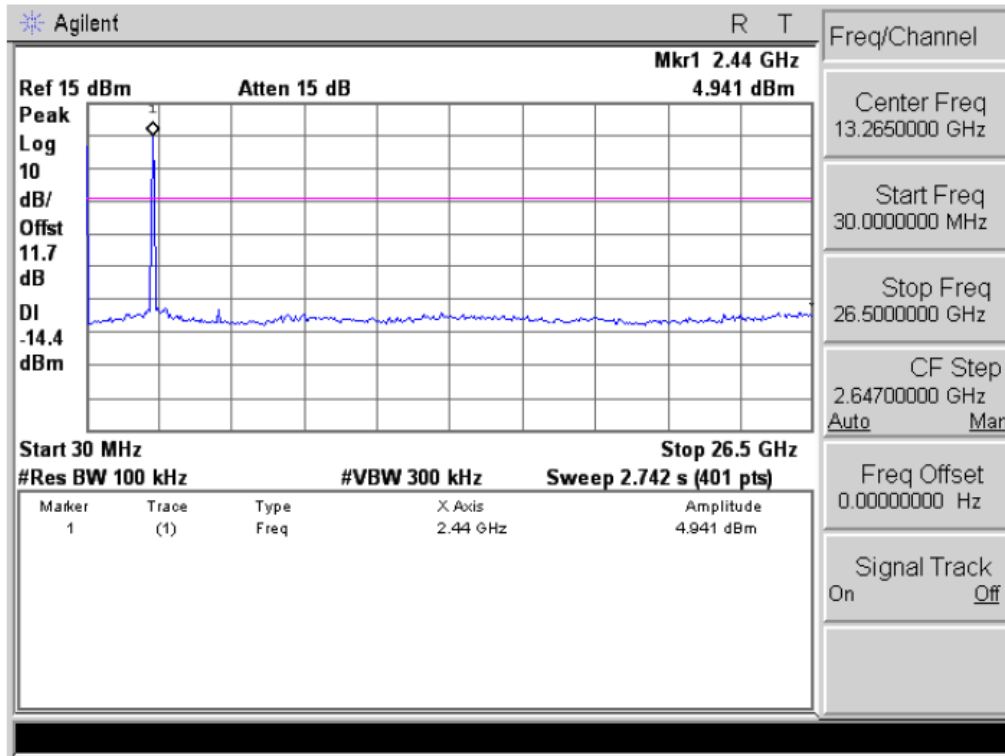

802.11b High channel

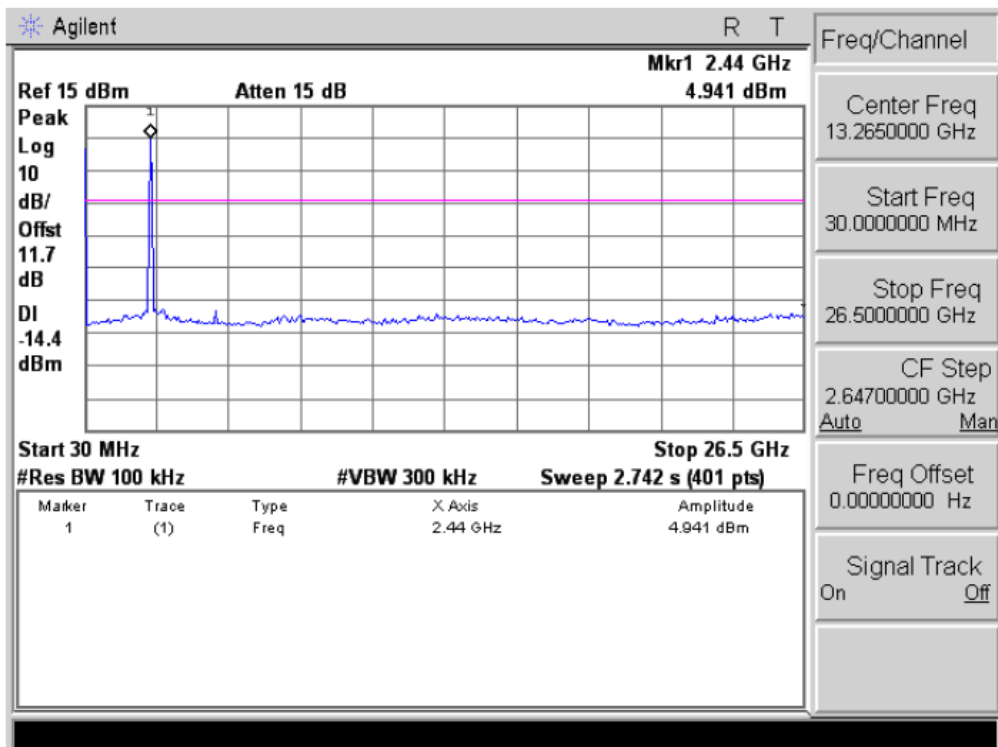



## 4. POWER SPECTRAL DENSITY TEST

### 4.1 APPLIED PROCEDURES / LIMIT

FCC Part15 (15.247) , Subpart C				
Section	Test Item	Limit	Frequency Range (MHz)	Result
15.247	Power Spectral Density	8 dBm (in any 3KHz)	2400-2483.5	PASS

#### 4.1.1 TEST PROCEDURE

1. Set analyzer center frequency to DTS channel center frequency.
2. Set the span to 1.5 times the DTS channel bandwidth.
3. Set the RBW  $\geq$  3 kHz.
4. Set the VBW  $\geq$  3 x RBW.
5. Detector = peak.
6. Sweep time = auto couple.
7. Trace mode = max hold.
8. Allow trace to fully stabilize.
9. Use the peak marker function to determine the maximum amplitude level.
10. If measured value exceeds limit, reduce RBW (no less than 3 kHz) and repeat.

#### 4.1.2 DEVIATION FROM STANDARD

No deviation.

#### 4.1.3 TEST SETUP



#### 4.1.4 EUT OPERATION CONDITIONS

The EUT tested system was configured as the statements of 2.1 Unless otherwise a special operating condition is specified in the follows during the testing.



### 4.1.5 TEST RESULTS

EUT :	11AC 433M DualBand Wireless USB Adapter	Model Name :	FX-WL140ACU-D
Temperature :	25°C	Relative Humidity :	60%
Pressure :	1015 hPa	Test Voltage :	DC 5V from PC input AC 120V/60Hz
Test Mode :	TX b Mode /CH01, CH06, CH11		

Frequency	Power Density (dBm)	Limit (dBm)	Result
2412 MHz	-13.67	8	PASS
2437 MHz	-13.73	8	PASS
2462 MHz	-13.98	8	PASS

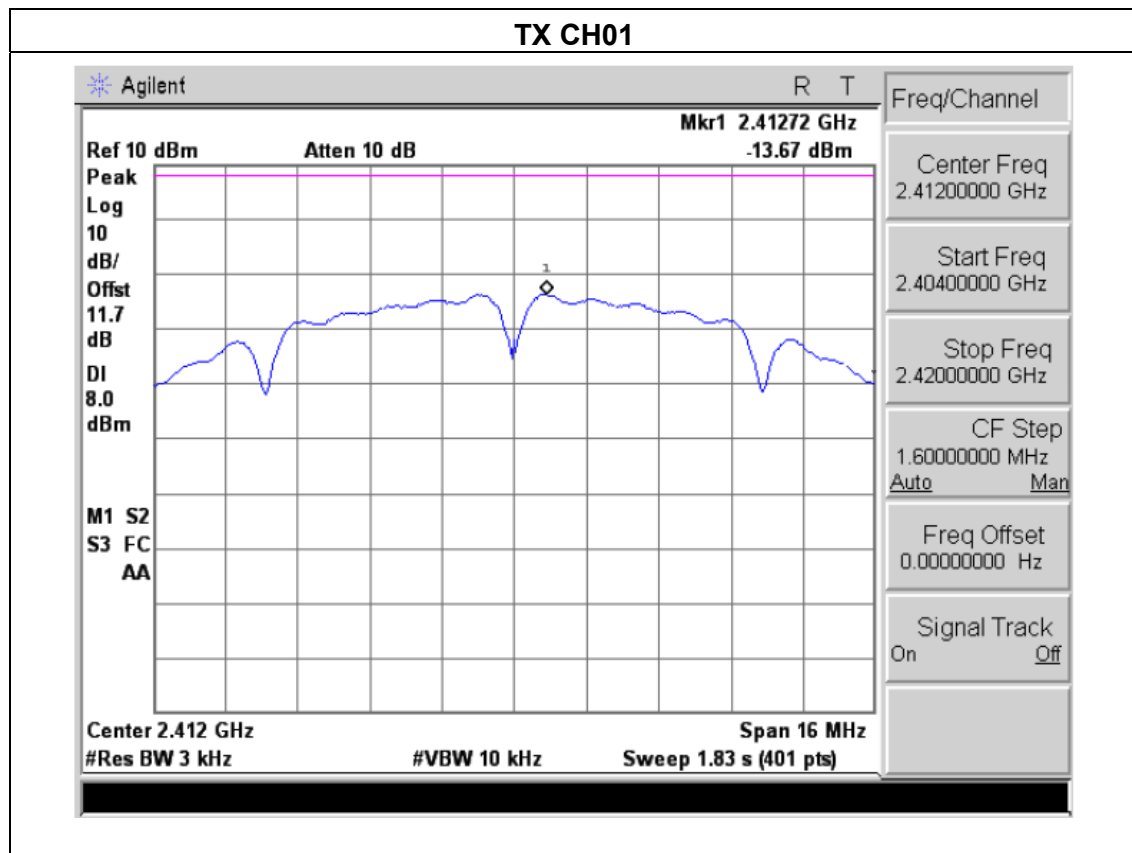

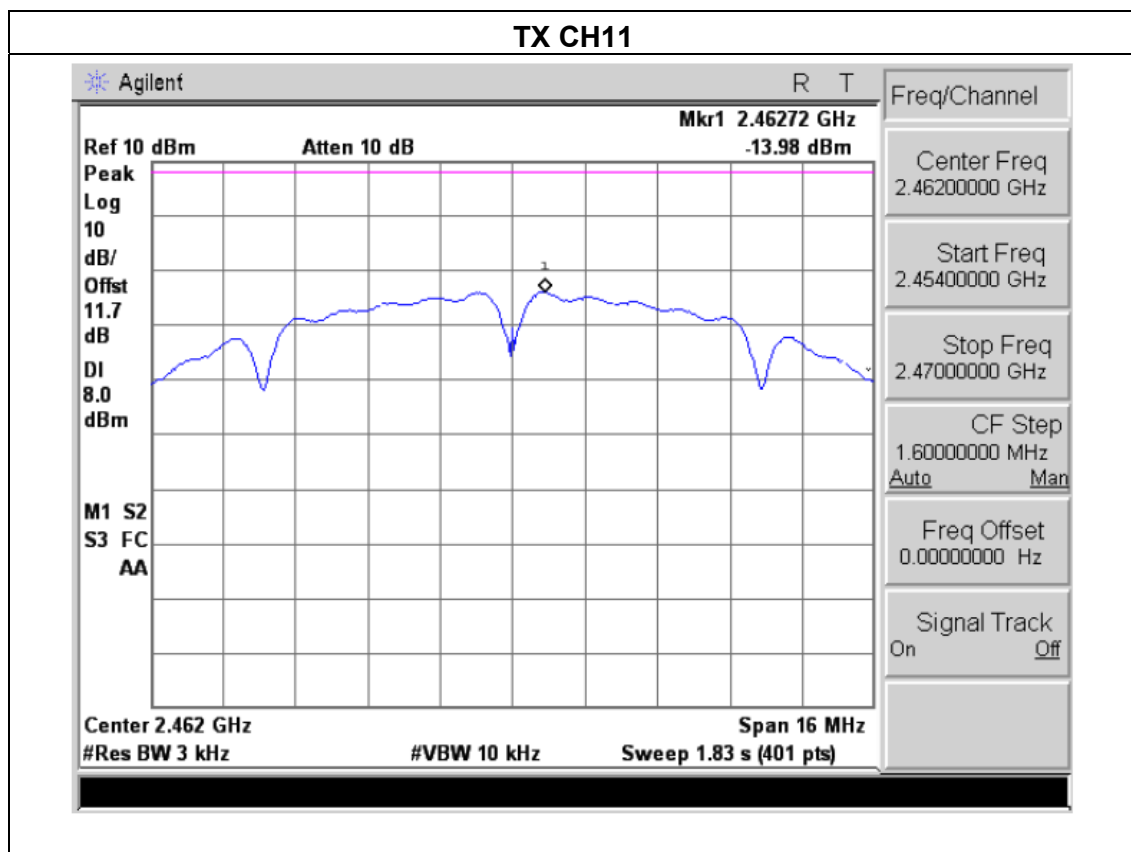
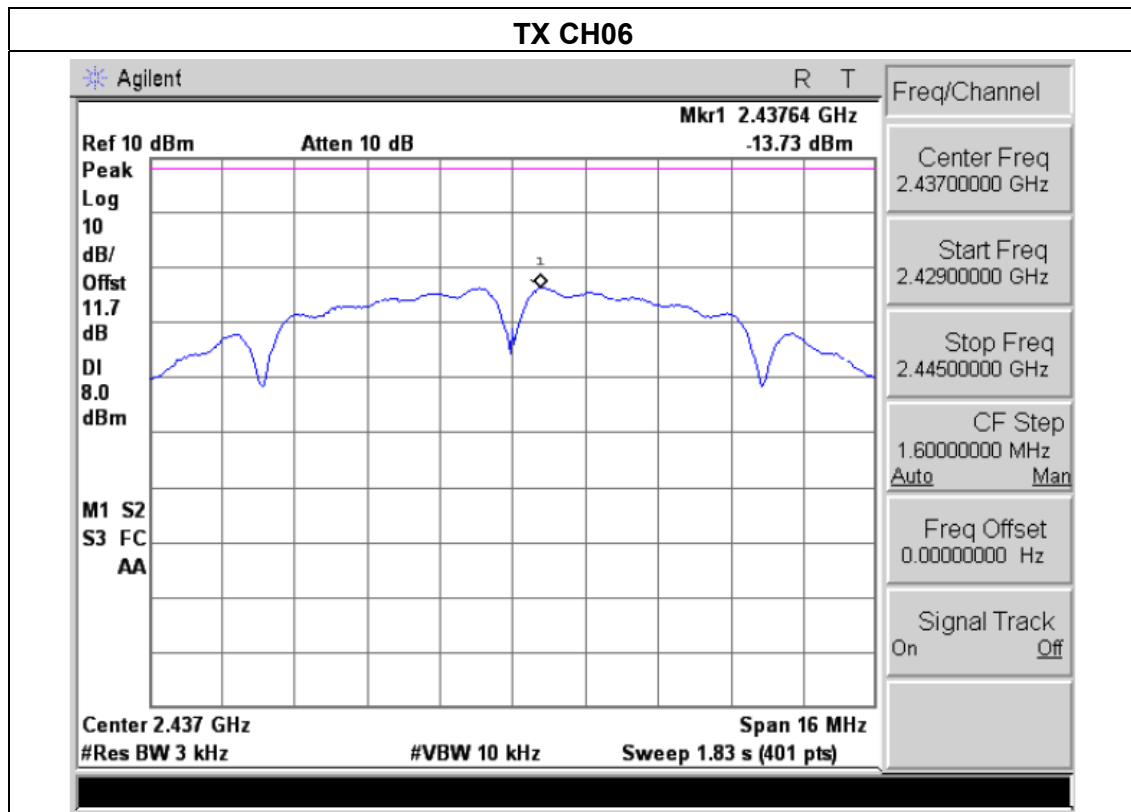



EUT :	11AC 433M DualBand Wireless USB Adapter	Model Name :	FX-WL140ACU-D
Temperature :	25°C	Relative Humidity :	60%
Pressure :	1015 hPa	Test Voltage :	DC 5V from PC input AC 120V/60Hz
Test Mode :	TX g Mode /CH01, CH06, CH11		

Frequency	Power Density (dBm)	Limit (dBm)	Result
2412 MHz	-13.89	8	PASS
2437 MHz	-13.95	8	PASS
2462 MHz	-14.18	8	PASS

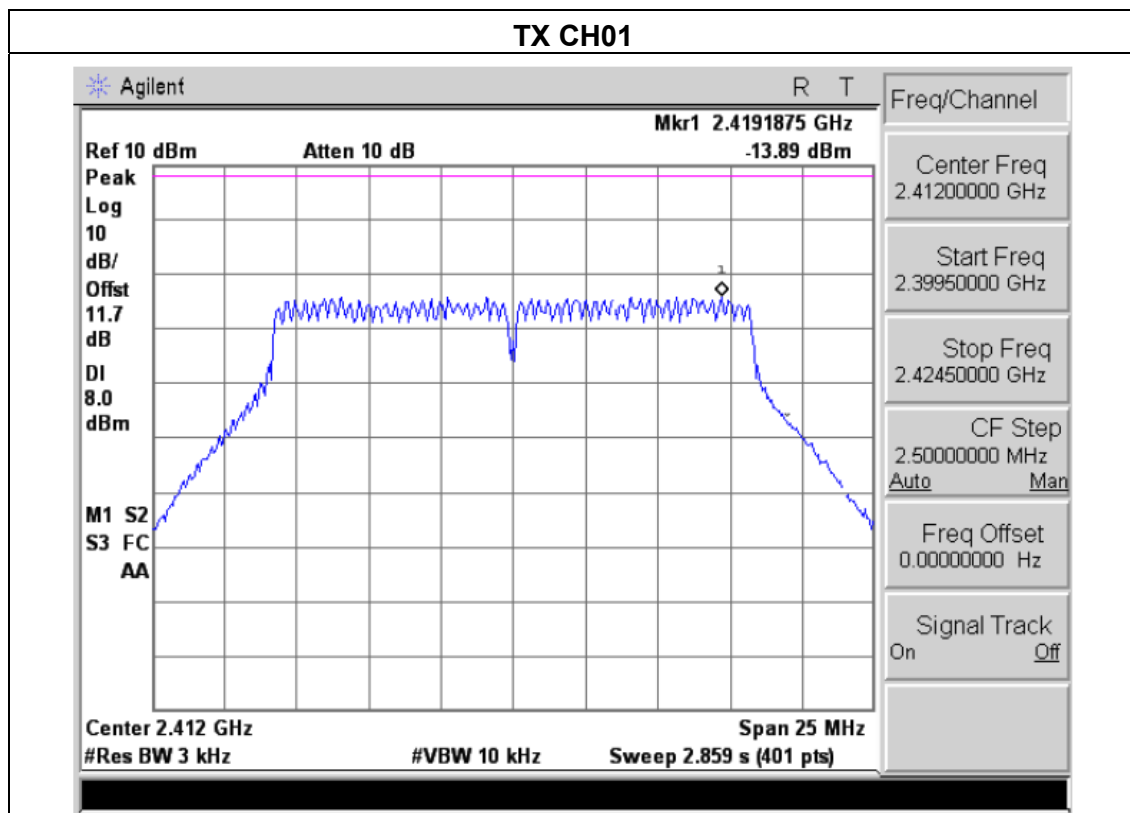

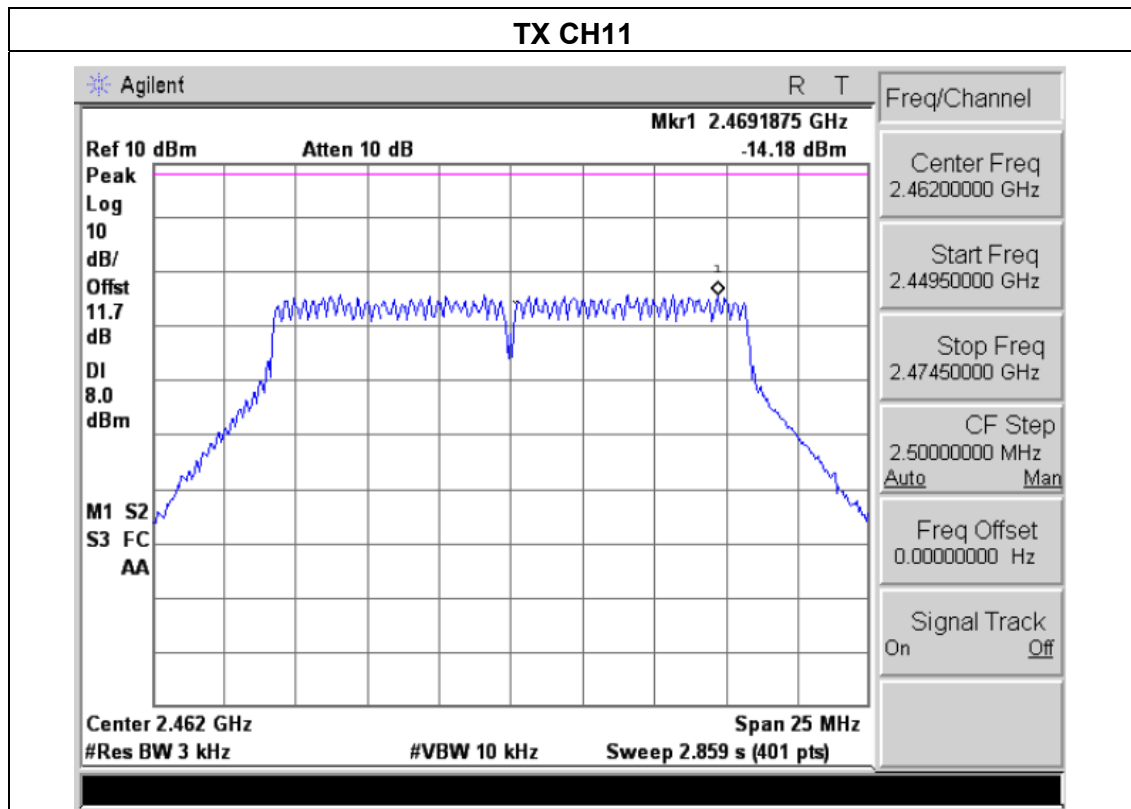
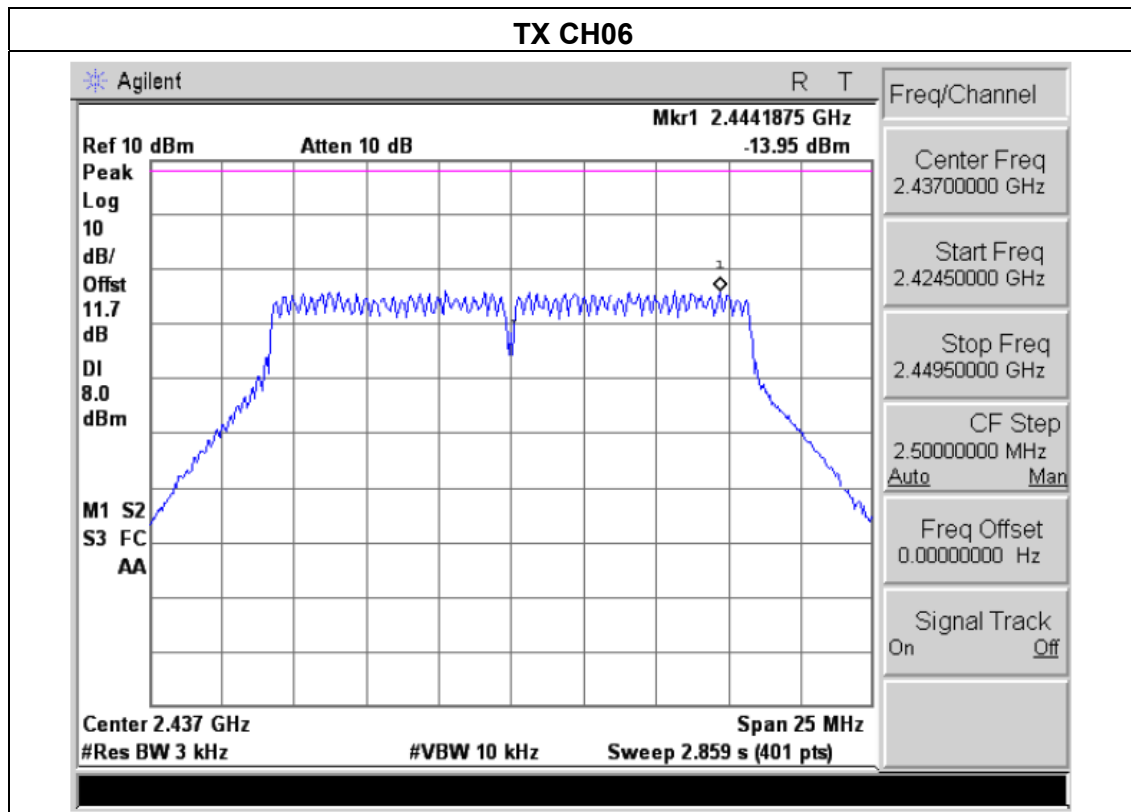





EUT :	11AC 433M DualBand Wireless USB Adapter	Model Name :	FX-WL140ACU-D
Temperature :	25°C	Relative Humidity :	60%
Pressure :	1015 hPa	Test Voltage :	DC 5V from PC input AC 120V/60Hz
Test Mode :	TX n Mode(20M) /CH01, CH06, CH11		

Frequency	Power Density (dBm)	Limit (dBm)	Result
2412 MHz	-15.38	8	PASS
2437 MHz	-14.29	8	PASS
2462 MHz	-15.42	8	PASS

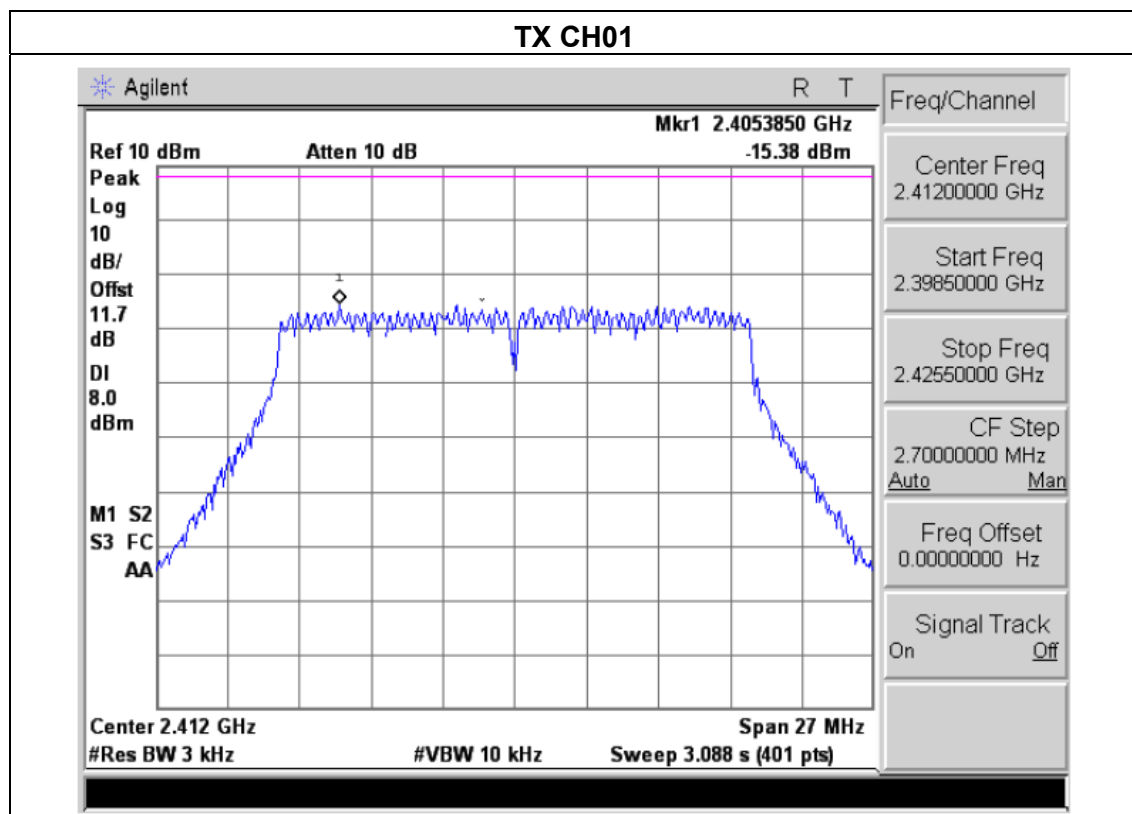

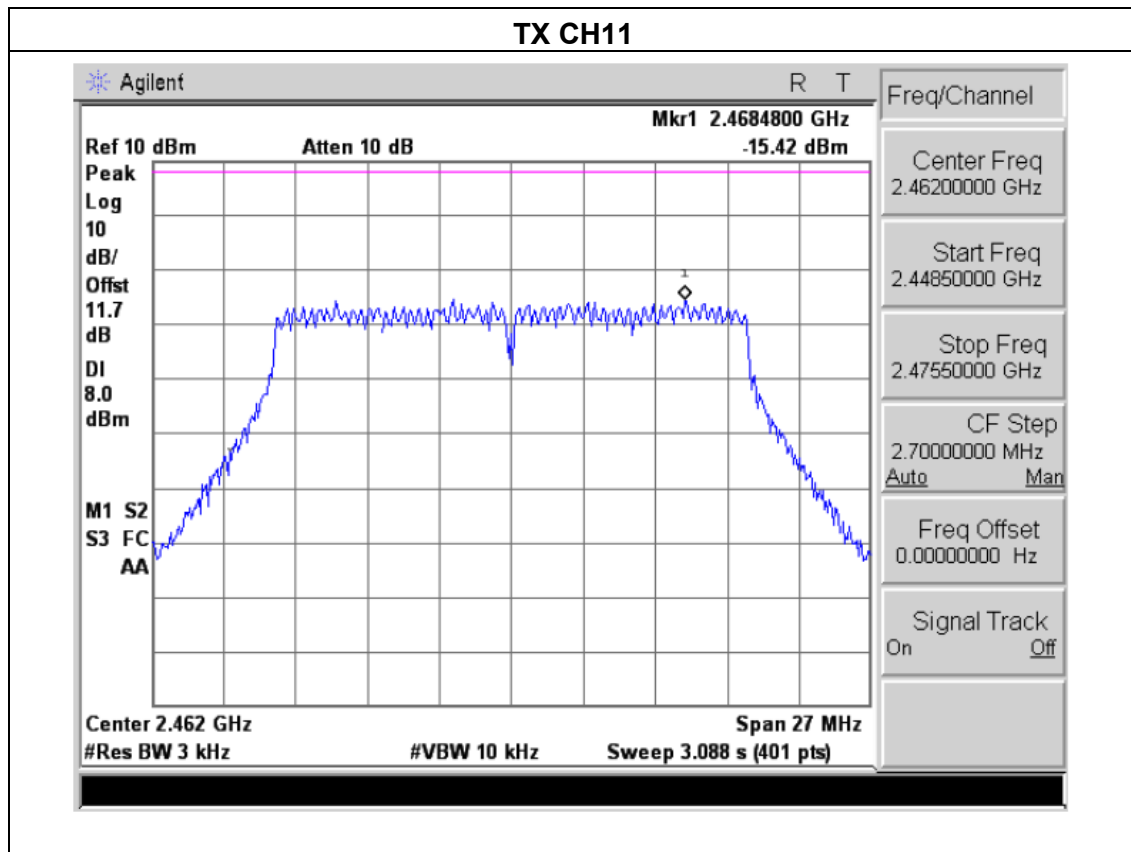
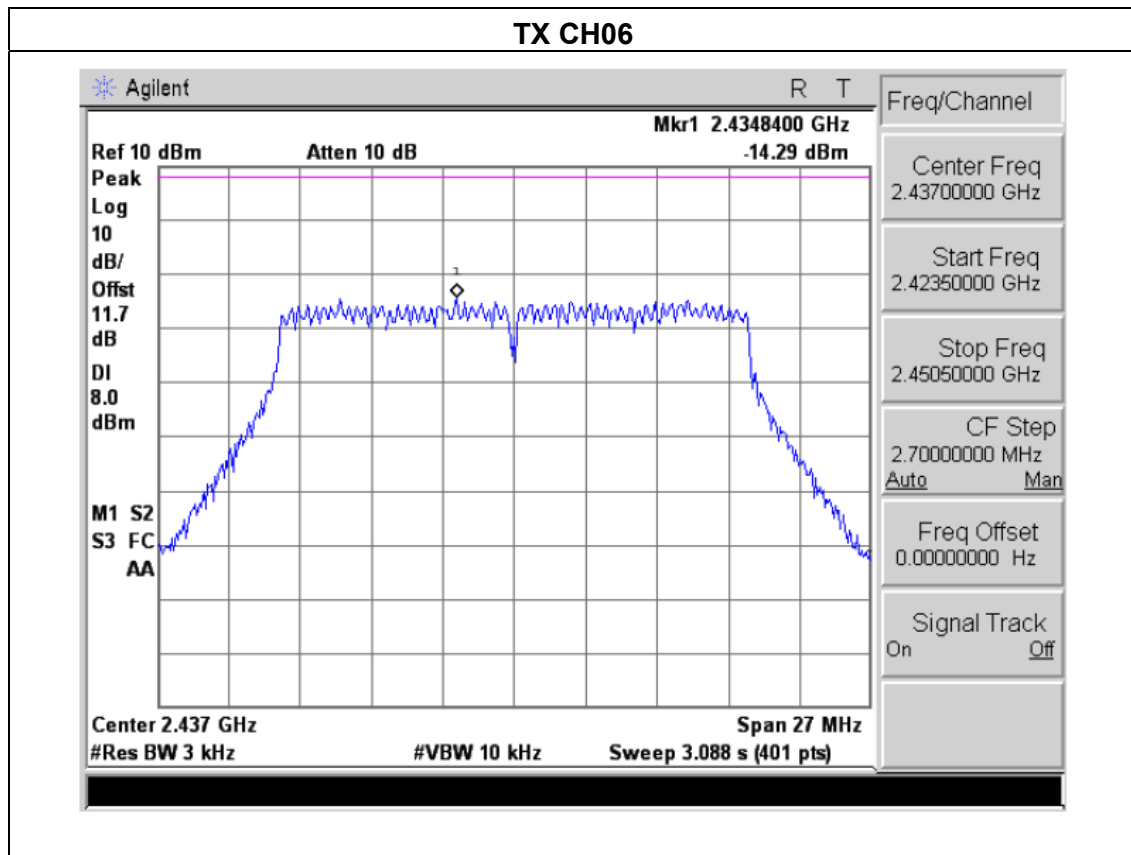



EUT :	11AC 433M DualBand Wireless USB Adapter	Model Name :	FX-WL140ACU-D
Temperature :	25°C	Relative Humidity :	60%
Pressure :	1015 hPa	Test Voltage :	DC 5V from PC input AC 120V/60Hz
Test Mode :	TX n Mode(20M) /CH01, CH06, CH11		

Frequency	Power Density (dBm)	Limit (dBm)	Result
2412 MHz	-15.36	8	PASS
2437 MHz	-16.31	8	PASS
2462 MHz	-15.54	8	PASS

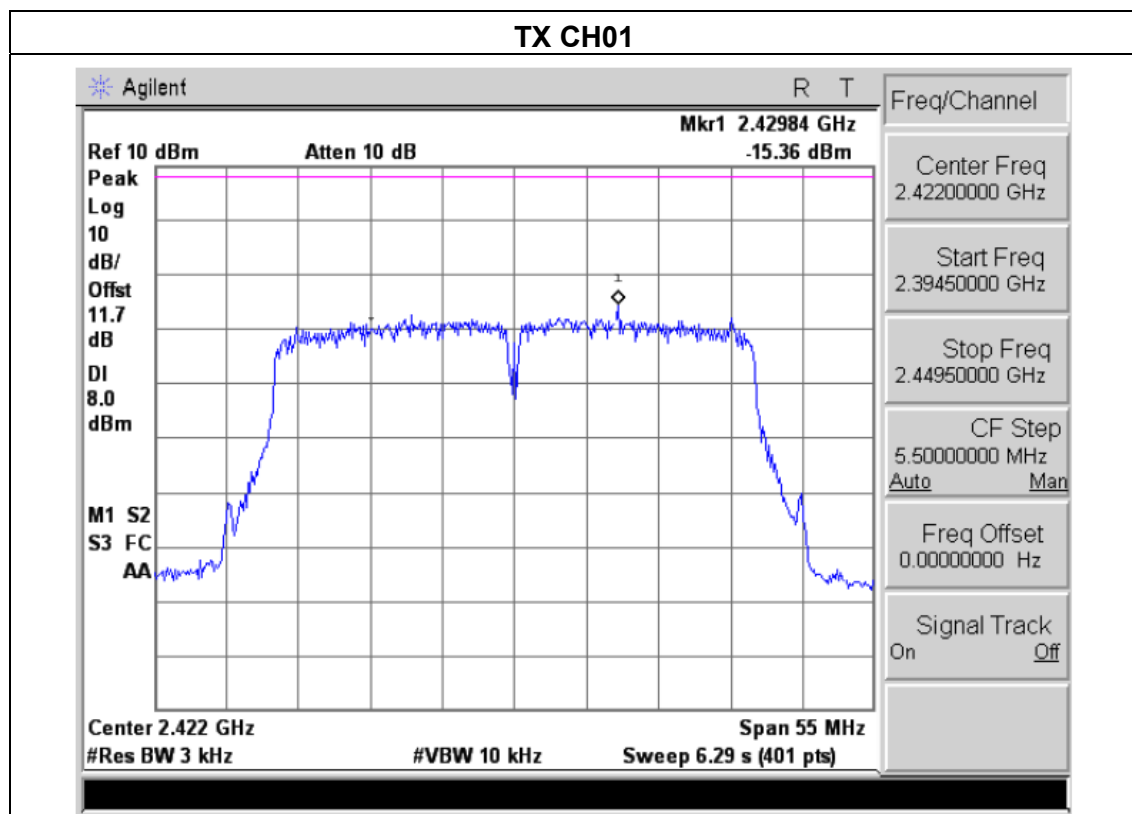

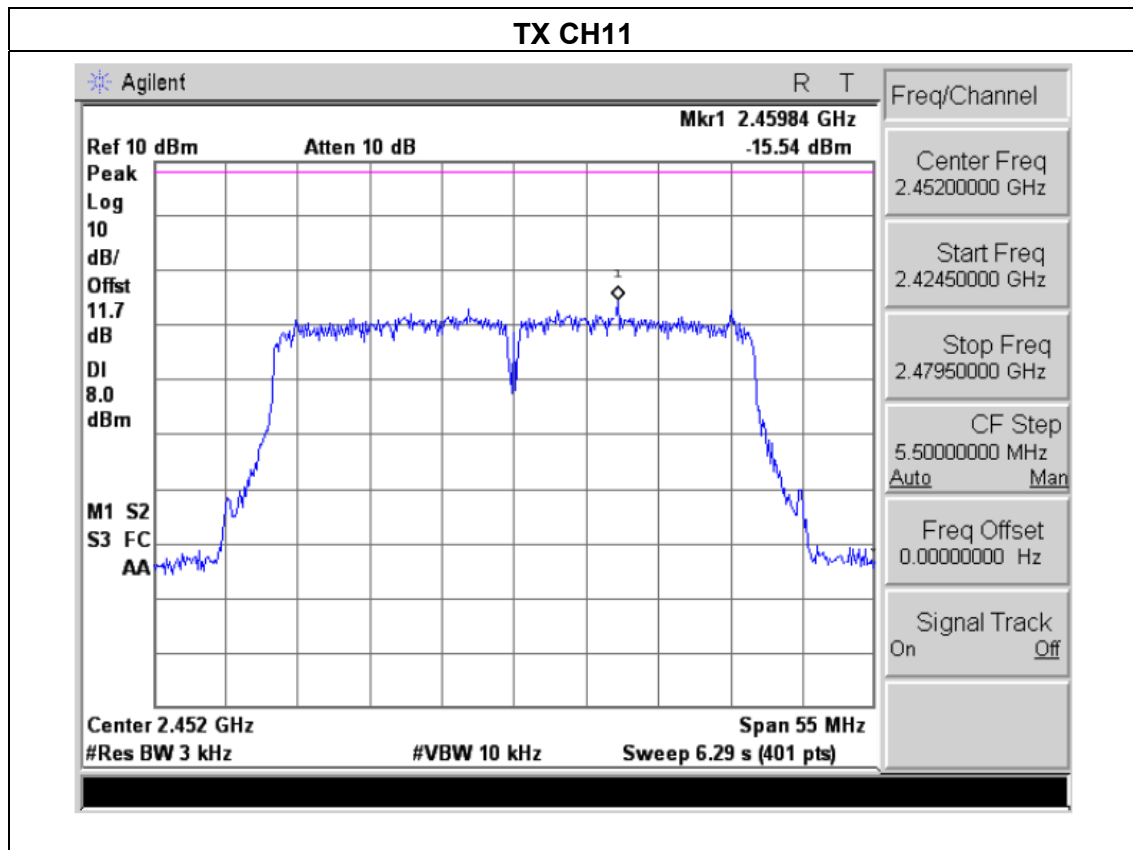
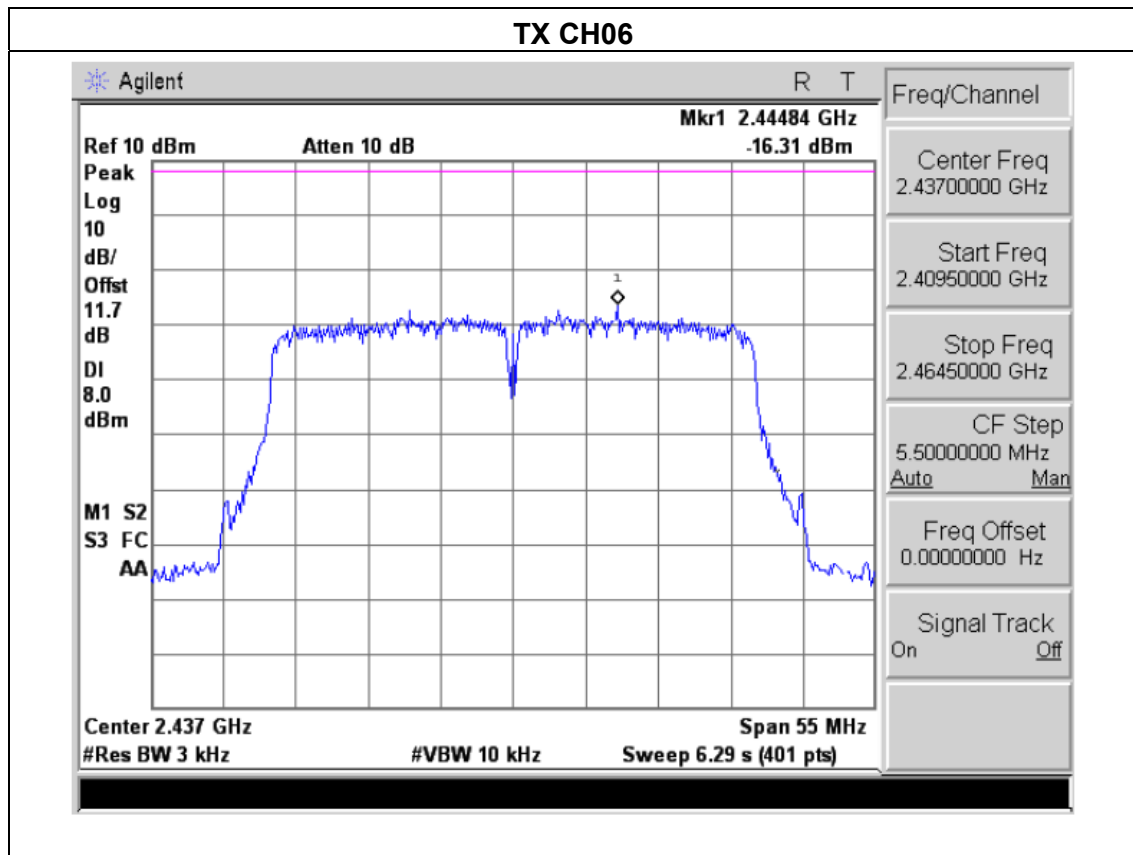

## 5. BANDWIDTH TEST

### 5.1 APPLIED PROCEDURES / LIMIT

FCC Part15 (15.247) , Subpart C				
Section	Test Item	Limit	Frequency Range (MHz)	Result
15.247(a)(2)	Bandwidth	$\geq 500\text{KHz}$ (6dB bandwidth)	2400-2483.5	PASS

#### 5.1.1 TEST PROCEDURE

1. Set resolution bandwidth (RBW) = 1-5% or DTS BW, not to exceed 100 kHz.
2. Set the video bandwidth (VBW)  $\geq 3 \times$  RBW.
3. Detector = Peak.
4. Trace mode = max hold.
5. Sweep = auto couple.
6. Allow the trace to stabilize.
7. Measure the maximum width of the emission that is constrained by the frequencies associated with the two outermost amplitude points (upper and lower) that are attenuated by 6 dB relative to the maximum level measured in the fundamental emission.

#### 5.1.2 DEVIATION FROM STANDARD

No deviation.

#### 5.1.3 TEST SETUP



#### 5.1.4 EUT OPERATION CONDITIONS

The EUT tested system was configured as the statements of 2.4 Unless otherwise a special operating condition is specified in the follows during the testing.



**5.1.5 TEST RESULTS**

EUT :	11AC 433M DualBand Wireless USB Adapter	Model Name :	FX-WL140ACU-D
Temperature :	25°C	Relative Humidity :	60%
Pressure :	1012 hPa	Test Voltage :	DC 5V from PC input AC 120V/60Hz
Test Mode :	TX b Mode /CH01, CH06, CH11		

Channel	Frequency (MHz)	6dB bandwidth (MHz)	Limit (kHz)	Result
Low	2412	10.035	500	Pass
Middle	2437	10.089	500	Pass
High	2462	10.066	500	Pass

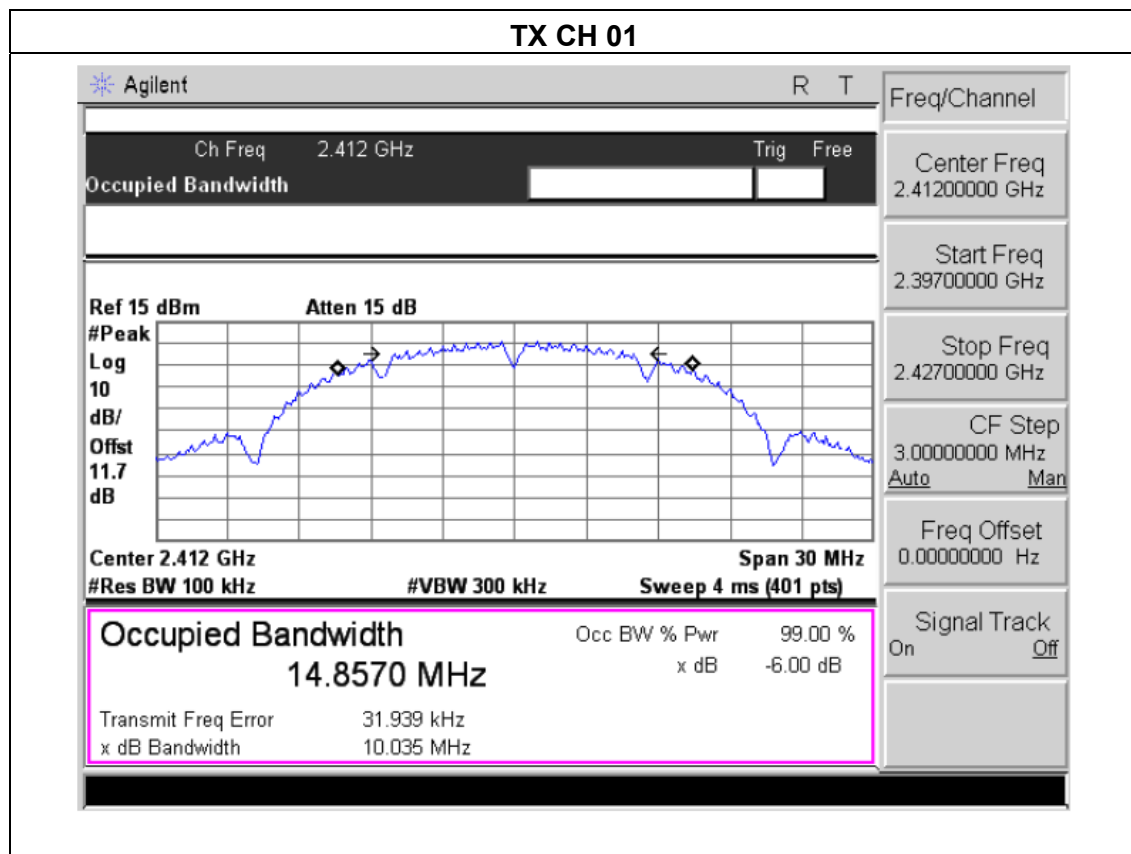

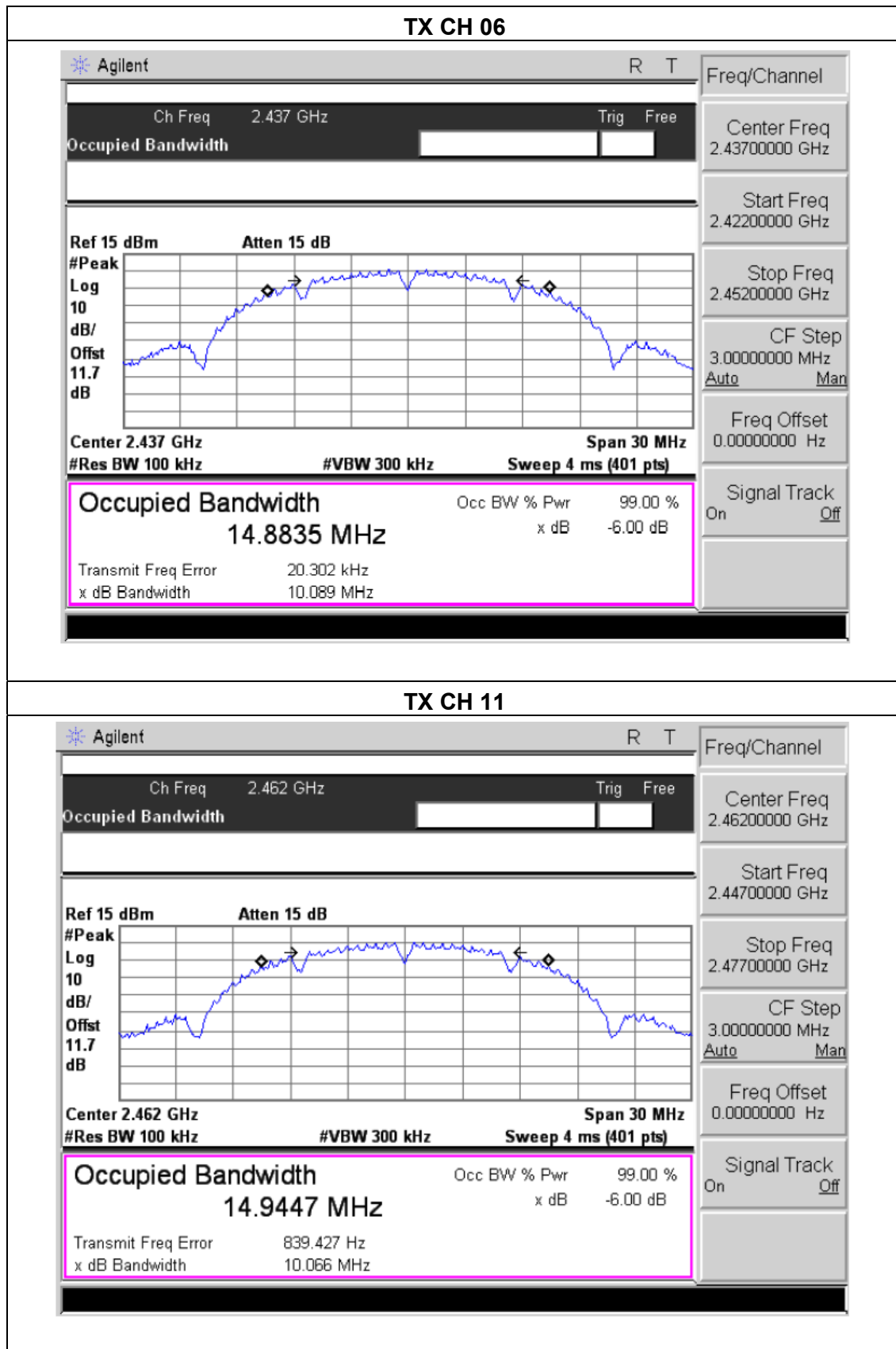



EUT :	11AC 433M DualBand Wireless USB Adapter	Model Name :	FX-WL140ACU-D
Temperature :	25°C	Relative Humidity :	60%
Pressure :	1012 hPa	Test Voltage :	DC 5V from PC input AC 120V/60Hz
Test Mode :	TX g Mode /CH01, CH06, CH11		

Channel	Frequency (MHz)	6dB bandwidth (MHz)	Limit (kHz)	Result
Low	2412	16.588	500	Pass
Middle	2437	16.544	500	Pass
High	2462	16.563	500	Pass

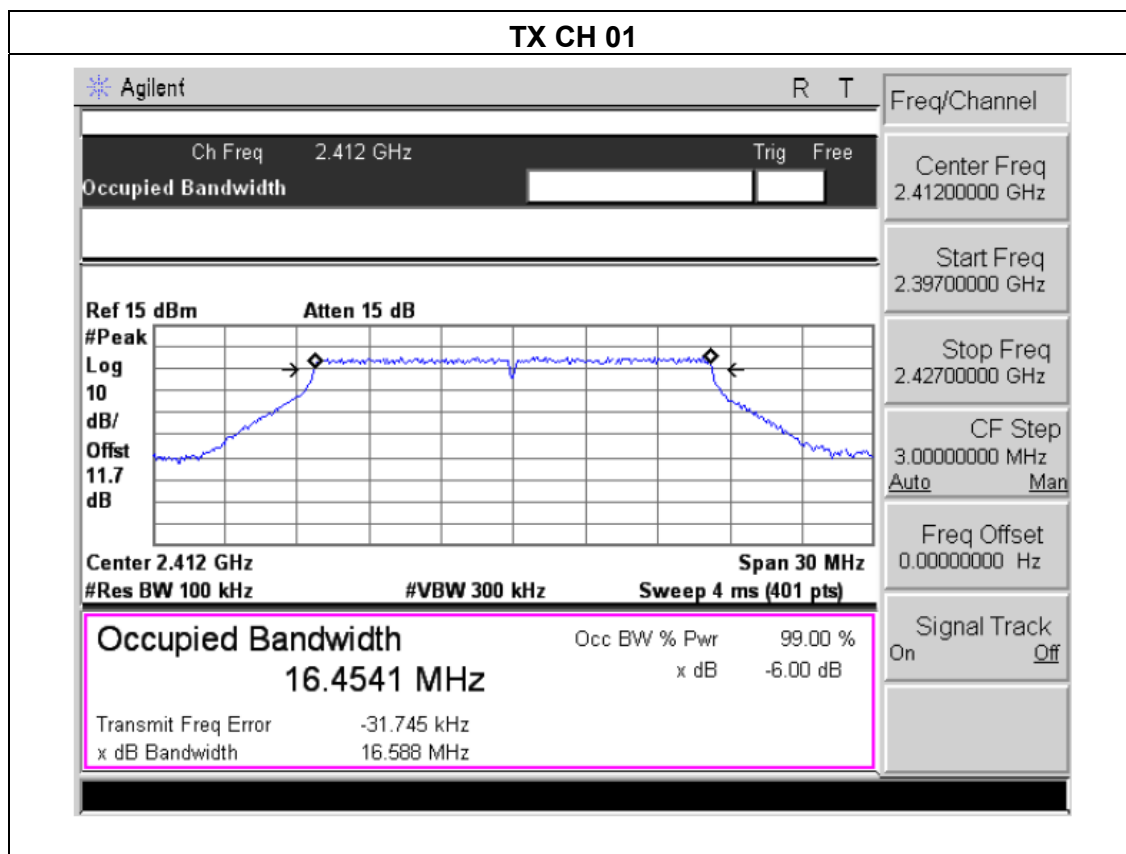



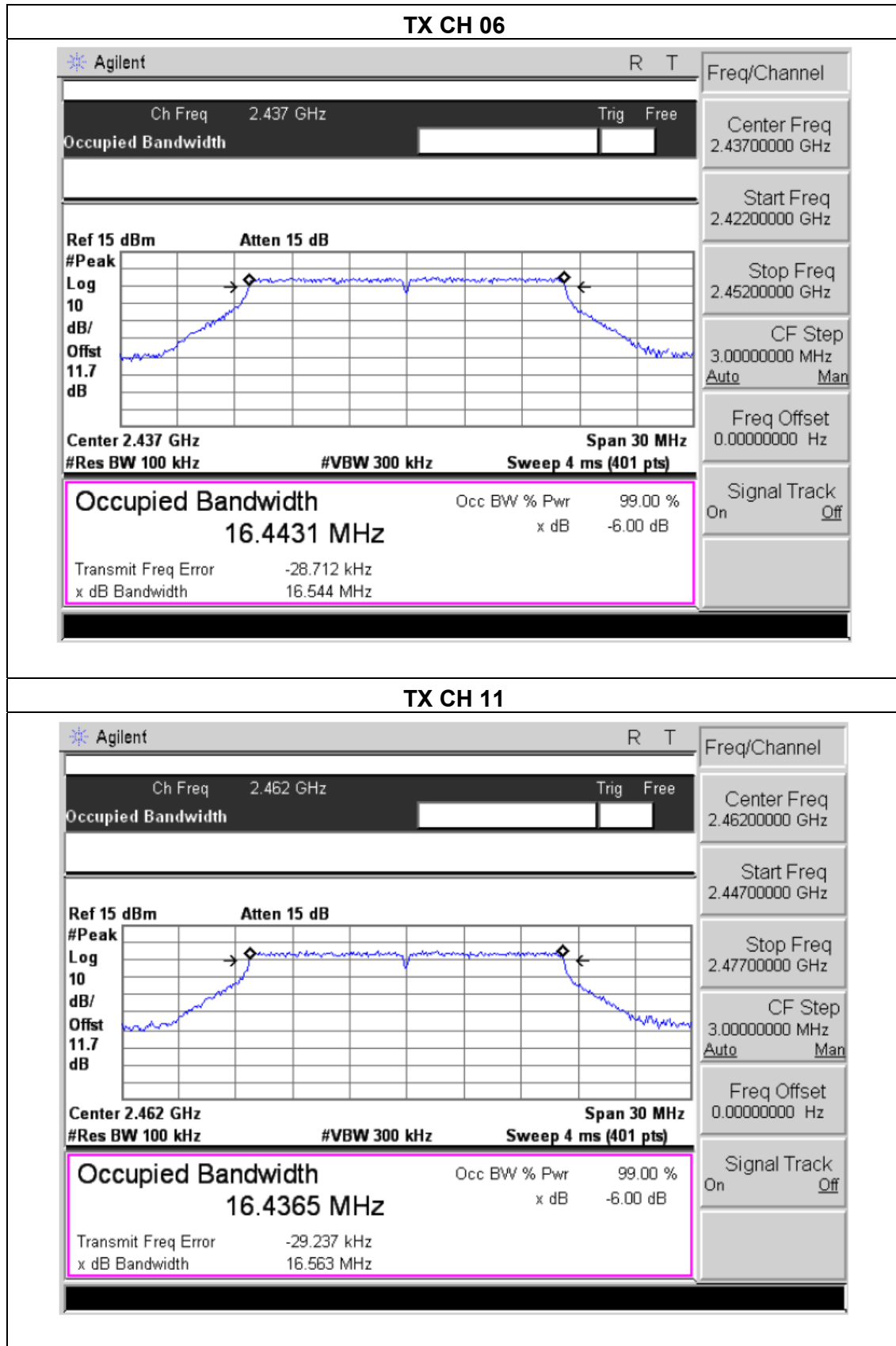



EUT :	11AC 433M DualBand Wireless USB Adapter	Model Name :	FX-WL140ACU-D
Temperature :	25°C	Relative Humidity :	60%
Pressure :	1012 hPa	Test Voltage :	DC 5V from PC input AC 120V/60Hz
Test Mode :	TX n Mode(20M) /CH01, CH06, CH11		

Channel	Frequency (MHz)	6dB bandwidth (MHz)	Limit (kHz)	Result
Low	2412	17.786	500	Pass
Middle	2437	17.808	500	Pass
High	2462	17.769	500	Pass

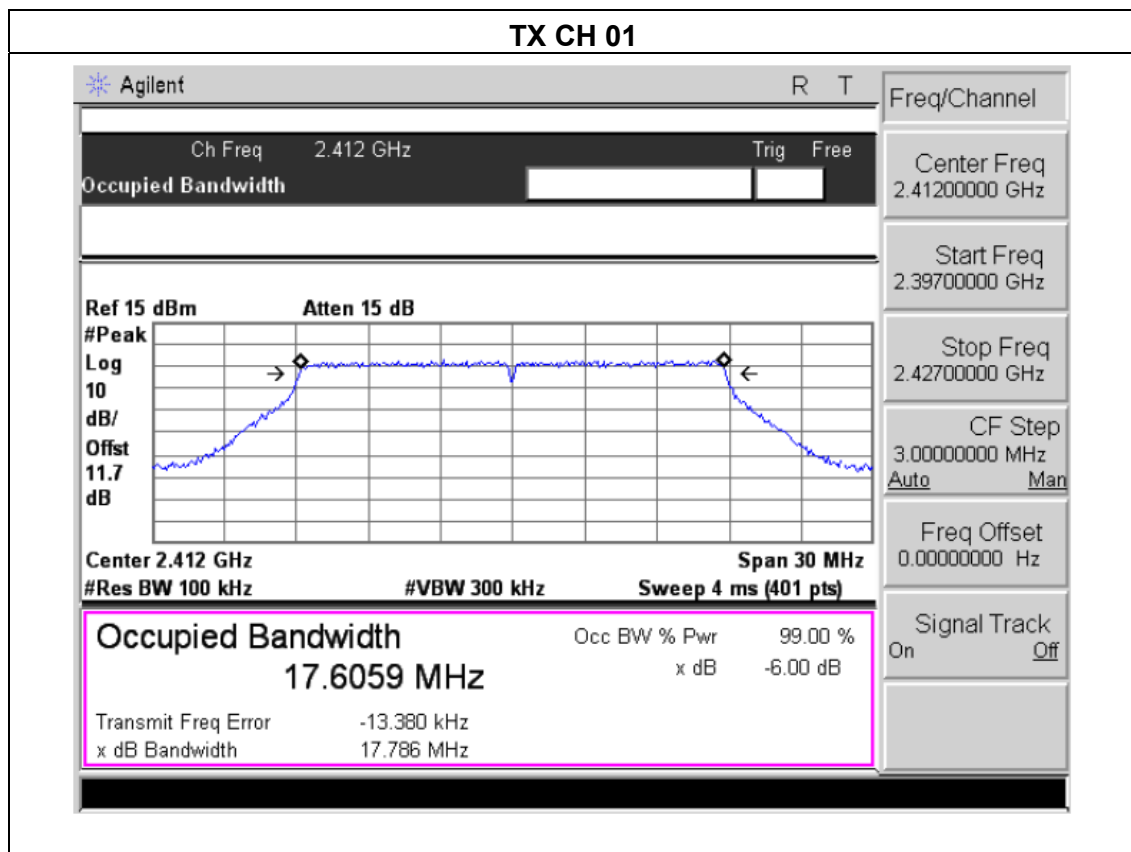

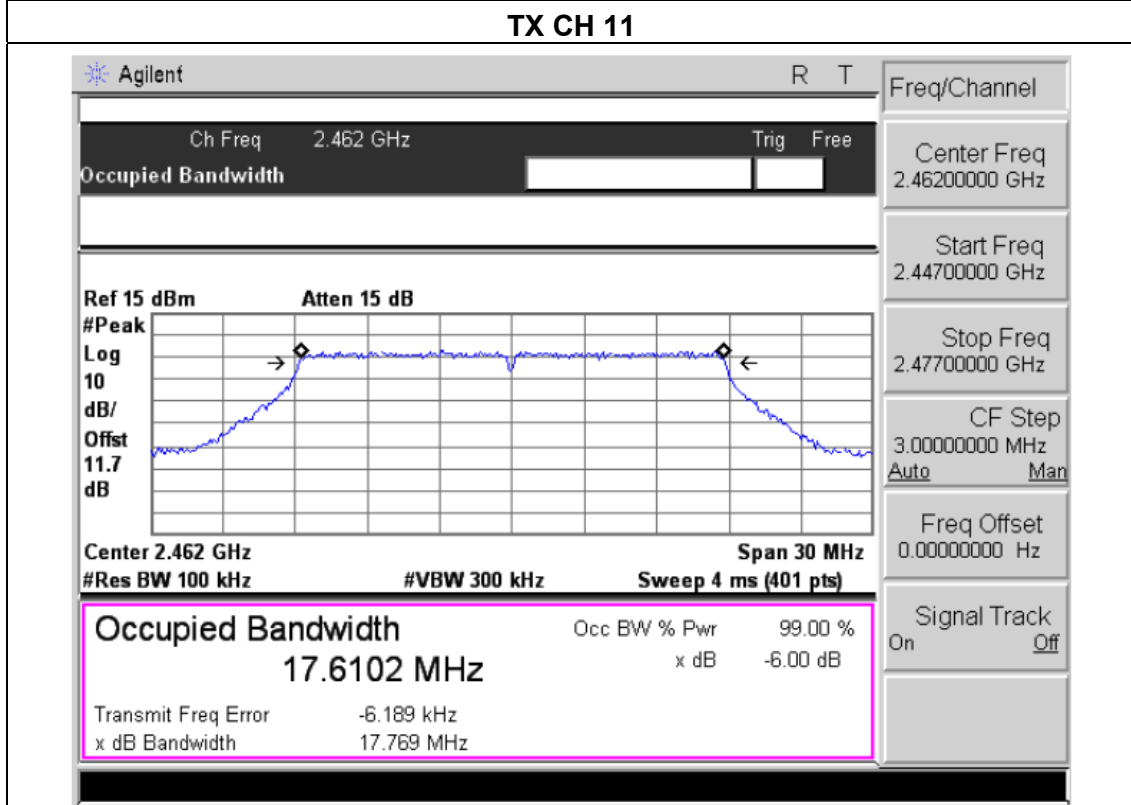
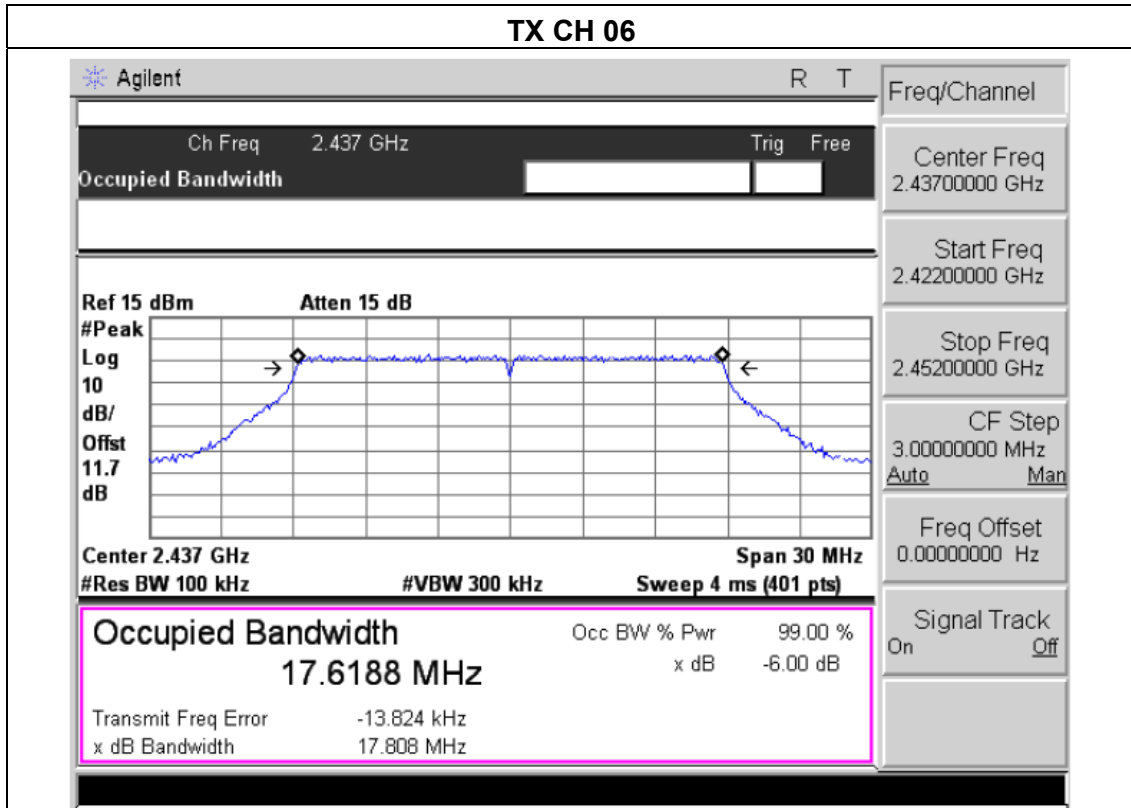



EUT :	11AC 433M DualBand Wireless USB Adapter	Model Name :	FX-WL140ACU-D
Temperature :	25°C	Relative Humidity :	60%
Pressure :	1012 hPa	Test Voltage :	DC 5V from PC input AC 120V/60Hz
Test Mode :	TX n Mode(40M) /CH03, CH06, CH9		

Channel	Frequency (MHz)	6dB bandwidth (MHz)	Limit (kHz)	Result
Low	2422	36.339	500	Pass
Middle	2437	36.397	500	Pass
High	2452	36.336	500	Pass

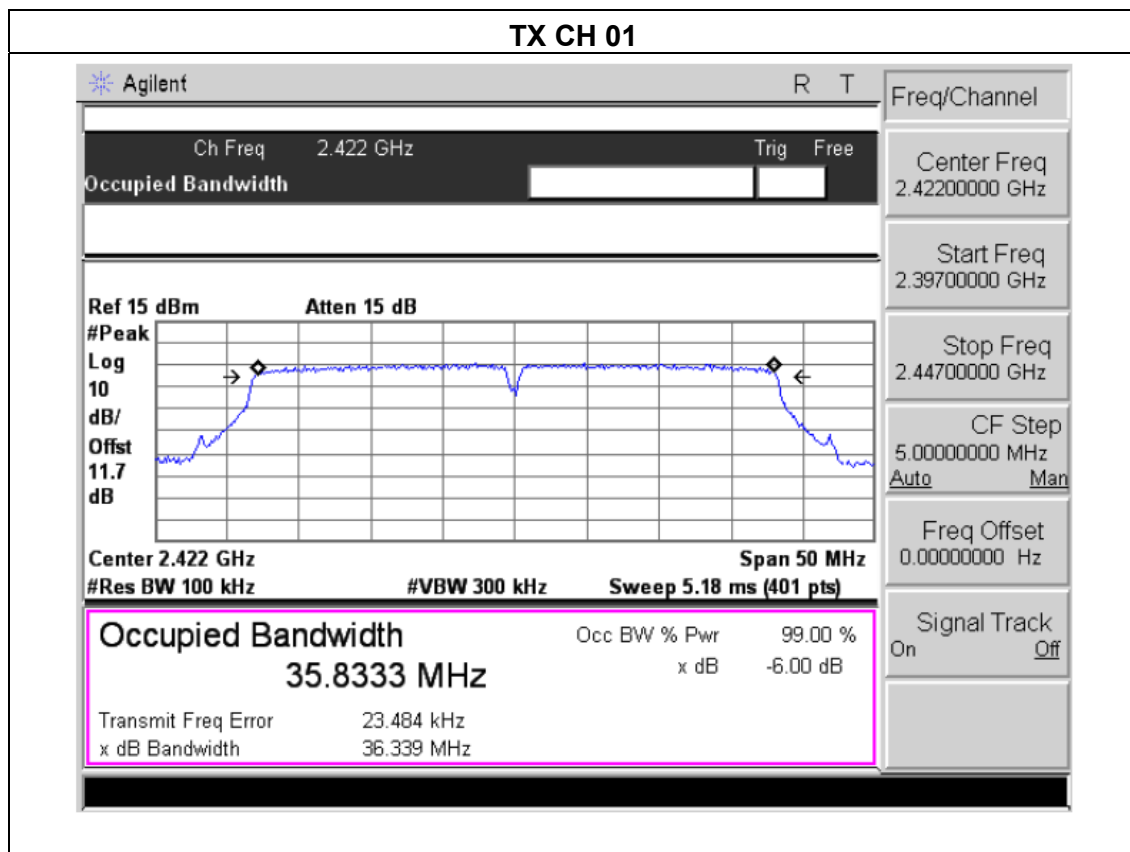

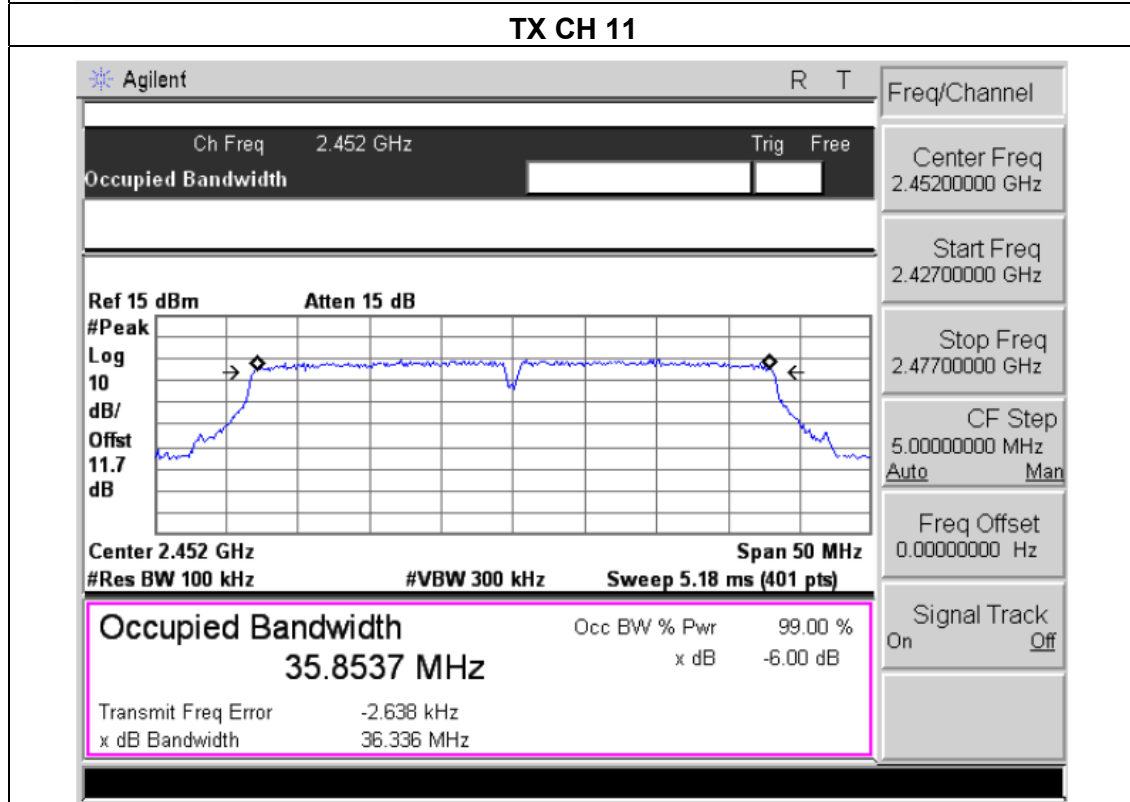
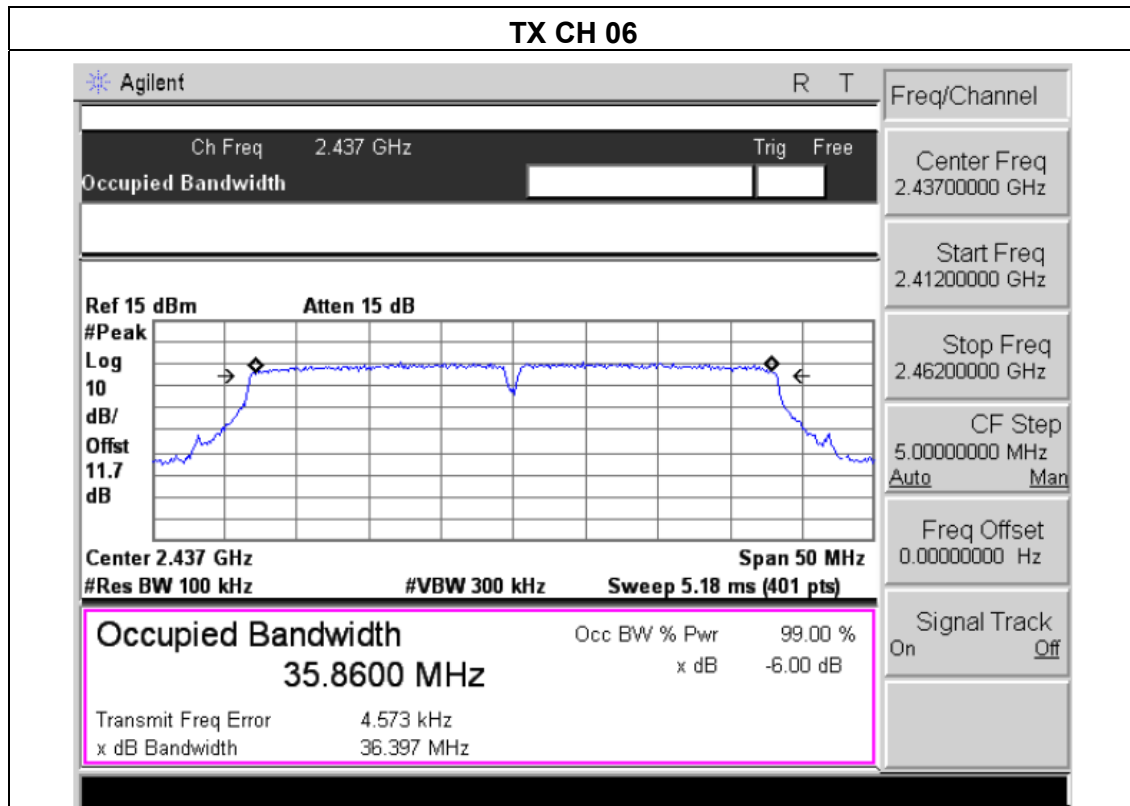



## 6. PEAK OUTPUT POWER TEST

### 6.1 APPLIED PROCEDURES / LIMIT

FCC Part15 (15.247) , Subpart C				
Section	Test Item	Limit	Frequency Range (MHz)	Result
15.247(b)(3)	Peak Output Power	1 watt or 30dBm	2400-2483.5	PASS

#### 6.1.1 TEST PROCEDURE

- a. The EUT was directly connected to the Power meter

#### 6.1.2 DEVIATION FROM STANDARD

No deviation.

#### 6.1.3 TEST SETUP



#### 6.1.4 EUT OPERATION CONDITIONS

The EUT tested system was configured as the statements of 2.4 Unless otherwise a special operating condition is specified in the follows during the testing.

**6.1.5 TEST RESULTS**

EUT :	11AC 433M DualBand Wireless USB Adapter	Model Name :	FX-WL140ACU-D
Temperature :	25°C	Relative Humidity :	60%
Pressure :	1012 hPa	Test Voltage :	DC 5V from PC input AC 120V/60Hz
Test Mode :	TX b/g/n(20M, 40M)		

<b>TX 802.11b Mode</b>			
Test Channe	Frequency	Maximum Conducted Output Power(AV)	LIMIT
	(MHz)	(dBm)	dBm
CH01	2412	8.86	30
CH06	2437	8.31	30
CH11	2462	8.24	30
<b>TX 802.11g Mode</b>			
CH01	2412	7.16	30
CH06	2437	7.35	30
CH11	2462	7.84	30
<b>TX 802.11n-HT20 Mode</b>			
CH01	2412	6.42	30
CH06	2437	6.27	30
CH11	2462	6.73	30
<b>TX 802.11n-HT40 Mode</b>			
CH01	2422	6.42	30
CH06	2437	6.27	30
CH11	2452	6.73	30



## 7. 100 KHZ BANDWIDTH OF FREQUENCY BAND EDGE

### APPLICABLE STANDARD

In any 100 kHz bandwidth outside the frequency band in which the spread spectrum or digitally modulated intentional radiator is operating, the radio frequency power that is produced by the intentional radiator shall be at least 20 dB below that in the 100 kHz bandwidth within the band that contains the highest level of the desired power, based on either an RF conducted or a radiated measurement, provided the transmitter demonstrates compliance with the peak conducted power limits. If the transmitter complies with the conducted power limits based on the use of RMS averaging over a time interval, as permitted under paragraph (b)(3) of this section, the attenuation required under this paragraph shall be 30 dB instead of 20 dB. Attenuation below the general limits specified in §15.209(a) is not required. In addition, radiated emissions which fall in the restricted bands, as defined in §15.205(a), must also comply with the radiated emission limits specified in §15.209(a) (see §15.205(c)).

### TEST PROCEDURE

- a) Check the calibration of the measuring instrument using either an internal calibrator or a known signal from an external generator.
- b) Position the EUT without connection to measurement instrument. Turn on the EUT and connect its antenna terminal to measurement instrument via a low loss cable. Then set it to any one measured frequency within its operating range, and make sure the instrument is operated in its linear range.
- c) Set RBW to 100 kHz and VBW of spectrum analyzer to 300 kHz with a convenient frequency span including 100 kHz bandwidth from band edge.
- d) Measure the highest amplitude appearing on spectral display and set it as a reference level. Plot the graph with marking the highest point and edge frequency.
- e) Repeat above procedures until all measured frequencies were complete.
- f) measurements done as described in KDB 558074 D01 DTS Meas Guidance, section 12.

### 7.1 DEVIATION FROM STANDARD

No deviation.





### 7.2 TEST SETUP



### 7.3 EUT OPERATION CONDITIONS

The EUT tested system was configured as the statements of 2.4 Unless otherwise a special operating condition is specified in the follows during the testing.

### 7.4 TEST RESULTS

For Radiated:

	Frequency (MHz)	Antenna polarization (H/V)	Worst Emission (dBuV/m)	Band edge Limit (dBuV/m)		Result
			PK	PK	AV	
802.11b Low/Middle /High	<2400	H	50.27	74.00	54.00	Pass
	<2400	V	49.57	74.00	54.00	Pass
	>2483.5	H	49.45	74.00	54.00	Pass
	>2483.5	V	50.14	74.00	54.00	Pass
802.11g Low/Middle /High	<2400	H	49.63	74.00	54.00	Pass
	<2400	V	49.38	74.00	54.00	Pass
	>2483.5	H	49.67	74.00	54.00	Pass
	>2483.5	V	50.11	74.00	54.00	Pass
802.11n (HT20) Low/Middle /High	<2400	H	50.16	74.00	54.00	Pass
	<2400	V	50.22	74.00	54.00	Pass
	>2483.5	H	50.18	74.00	54.00	Pass
	>2483.5	V	50.17	74.00	54.00	Pass
802.11n (HT40) Low/Middle /High	<2400	H	50.08	74.00	54.00	Pass
	<2400	V	50.14	74.00	54.00	Pass
	>2483.5	H	49.49	74.00	54.00	Pass
	>2483.5	V	50.07	74.00	54.00	Pass

If the PK measured levels comply with average limit, then the average level were deemed to comply with average limit.



For conducted:

802.11b: Band Edge, Left Side

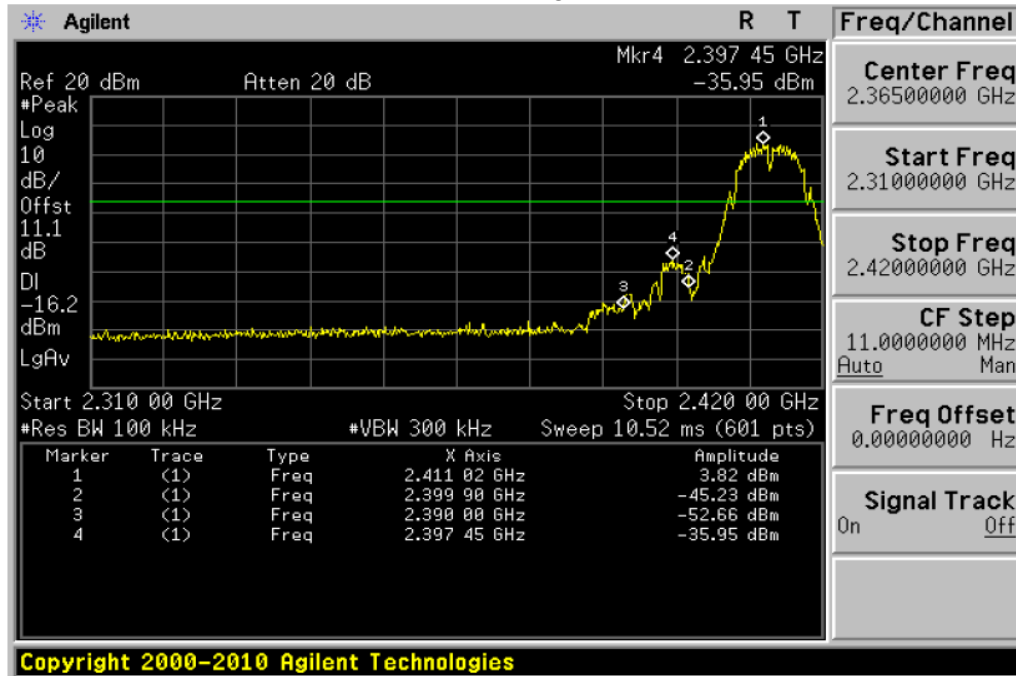

802.11b: Band Edge, Right Side





802.11g: Band Edge, Left Side

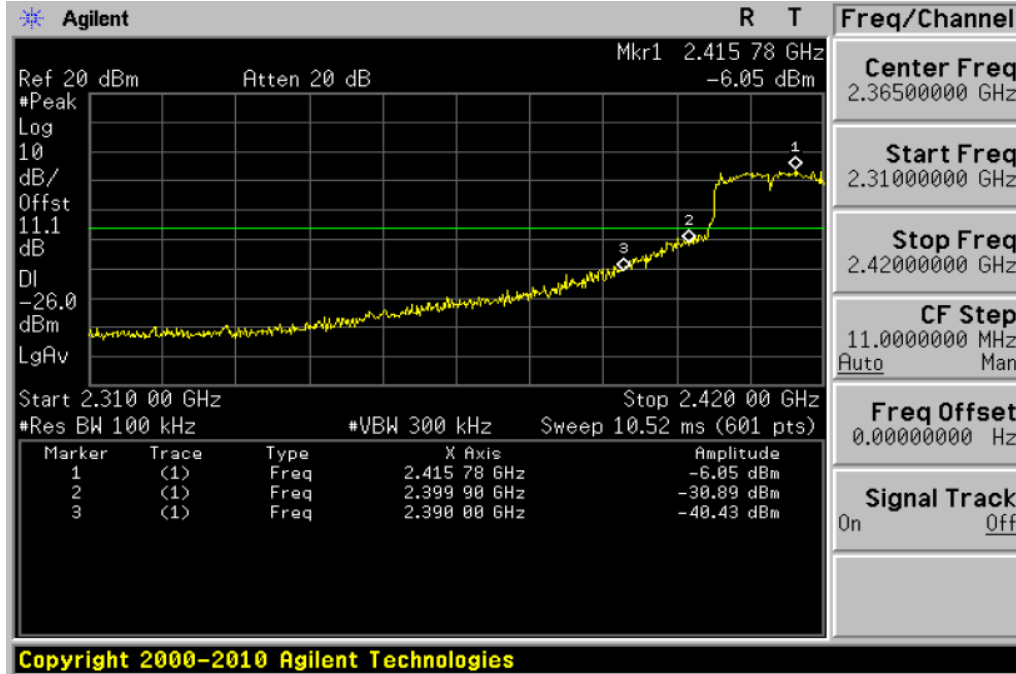

802.11g: Band Edge, Right Side

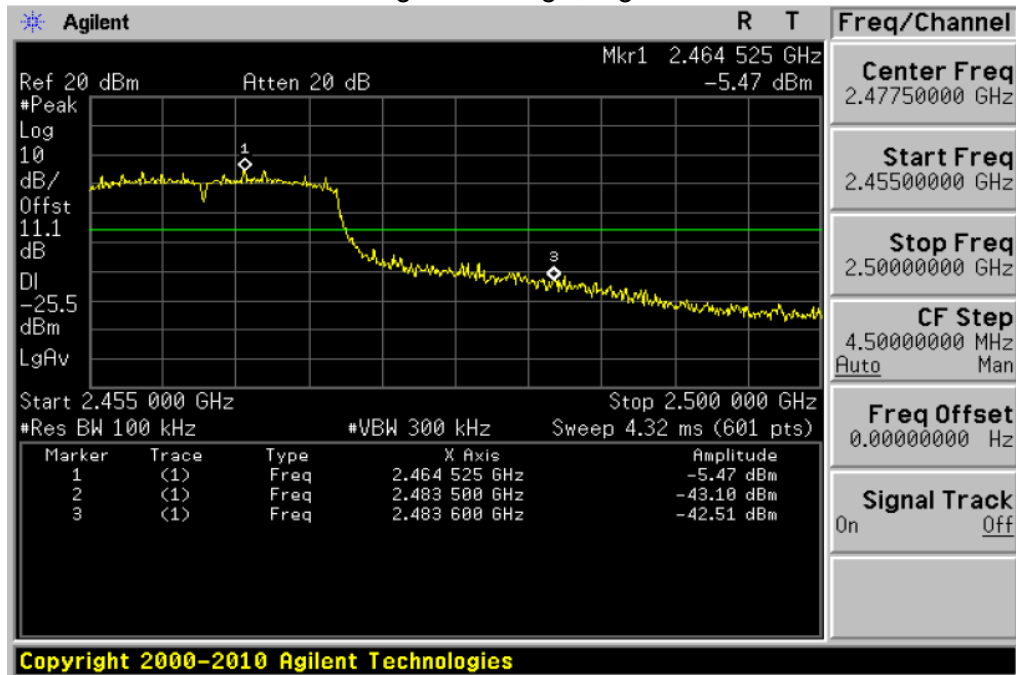



802.11n-HT20: Band Edge, Left Side

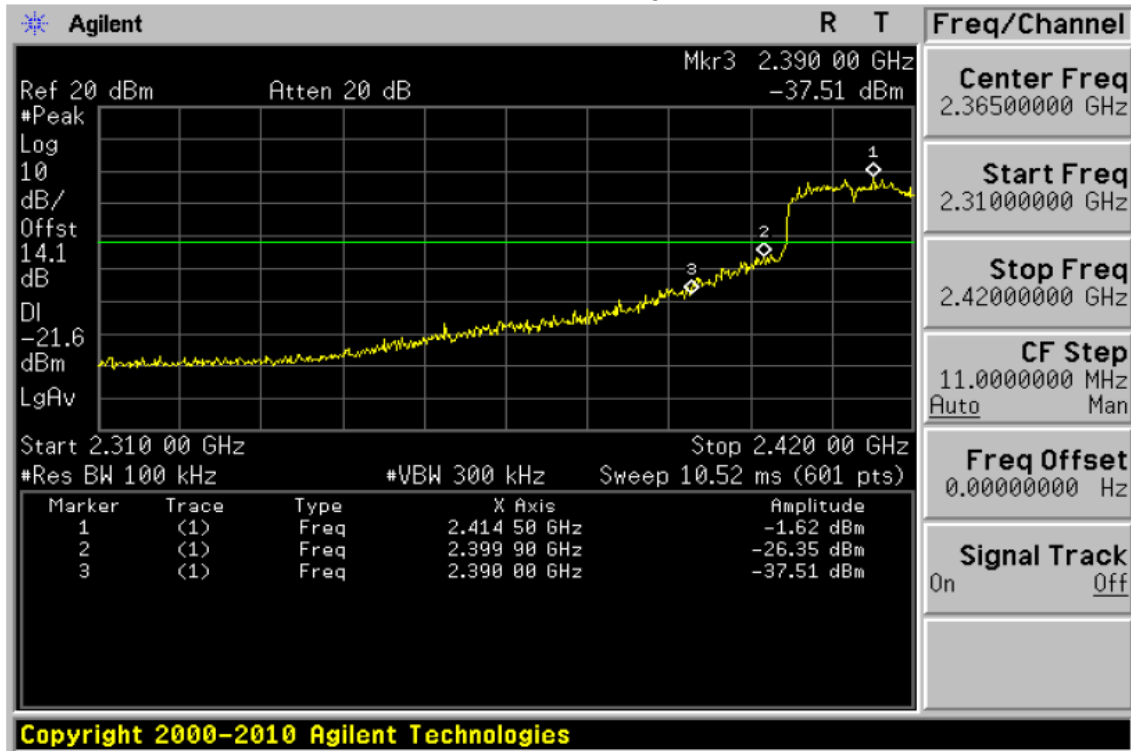

802.11n-HT20: Band Edge, Right Side

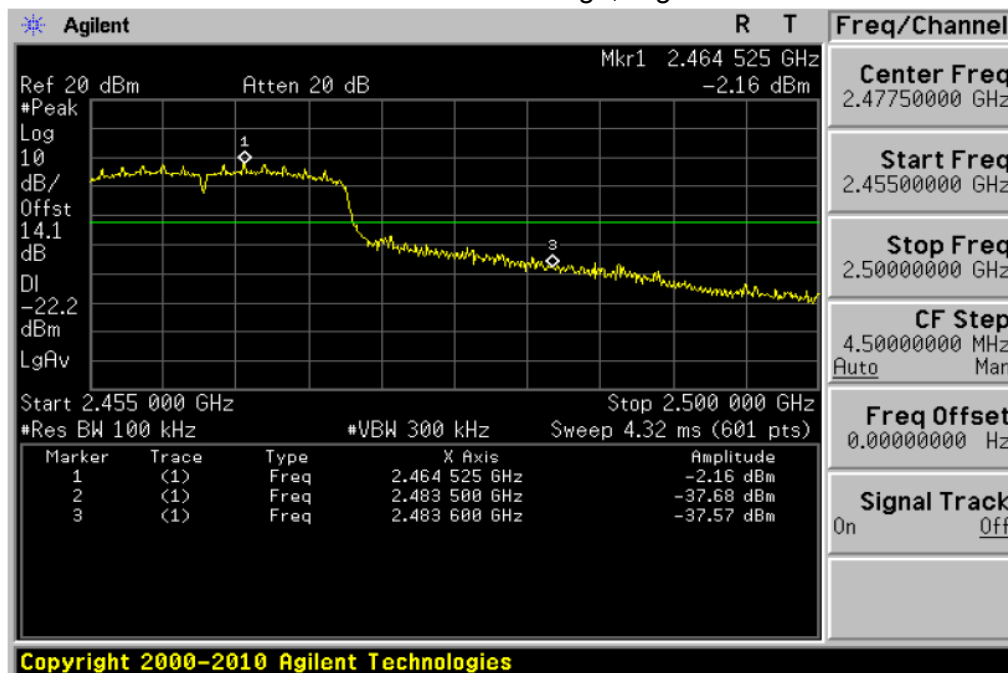



802.11n-HT40: Band Edge, Left Side

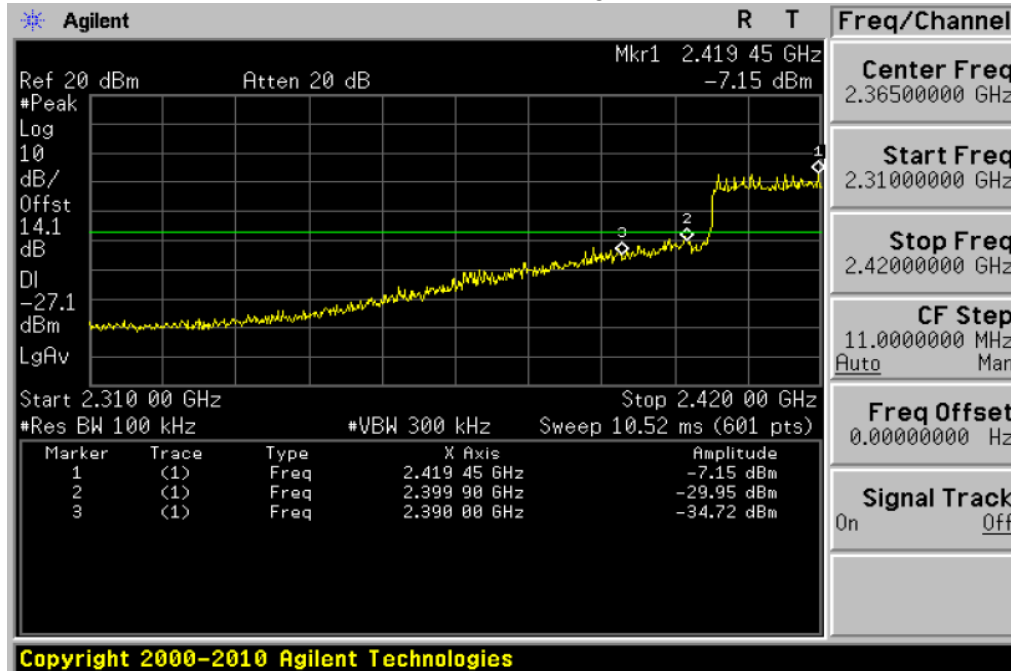

802.11n-HT40: Band Edge, Right Side

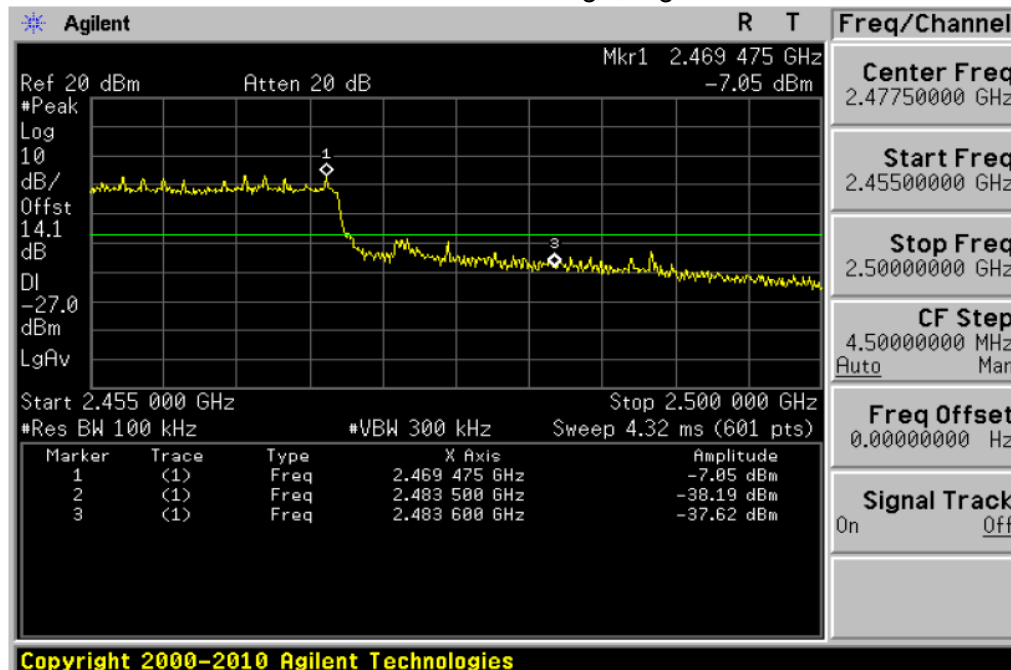



## 8. DUTY CYCLE OF TEST SIGNAL

### 8.1 STANDARD REQUIREMENT

Pre-analysis Check: While conducting average power measurement, duty cycle of each mode shall be checked to ensure its duty cycle in order to compensate for the loss due to insufficient ratio of duty cycle.

All duty cycle is pre-scanned, and result as obtained below shows only the most representative ones where duty cycle is conducted as the given transmission with given virtual operation that expresses the percentage.

### 8.2 FORMULA:

Duty Cycle =  $T_{on} / (T_{on} + T_{off})$

### Measurement Procedure:

1. Set span = Zero
2. RBW = 8MHz
3. VBW = 8MHz,
4. Detector = Peak

### Duty Cycle:

	Duty Cycle	Duty Fator (dB)
802.11b	95.5%	0.20
802.11g	96.2%	0.17
802.11n(HT20)	99.0%	0.00
802.11n(HT40)	96.5%	0.16

Duty Cycle Factor:  $10 * \log (1/0.955) = 0.499$

Duty Cycle Factor:  $10 * \log (1/0.962) = 0.497$

Duty Cycle Factor:  $10 * \log (1/0.99) = 0.01$

Duty Cycle Factor:  $10 * \log (1/0.965) = 1.404$



### DUTY CYCLE TEST SIGNAL Measurement Result

802.11 b

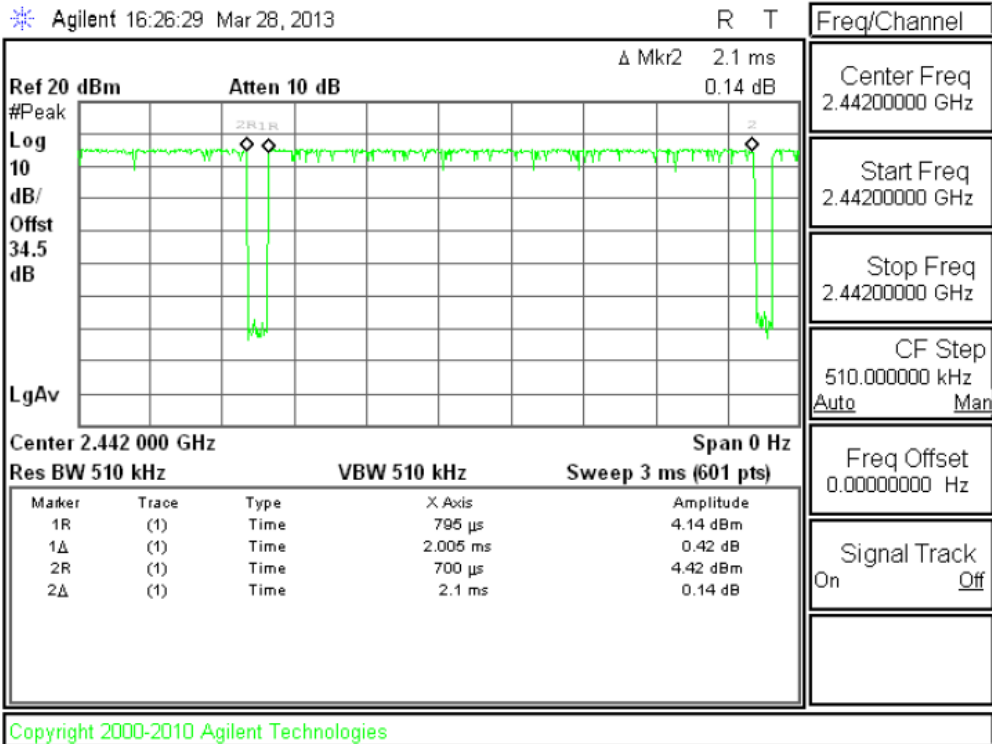

802.11g

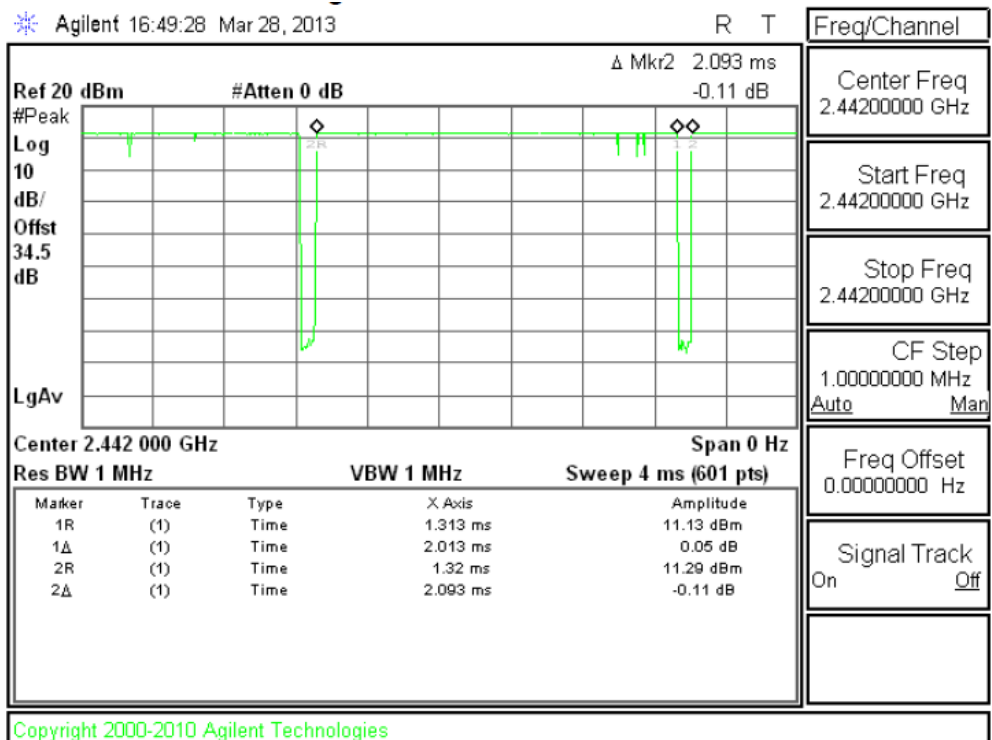



802.11n(HT20)

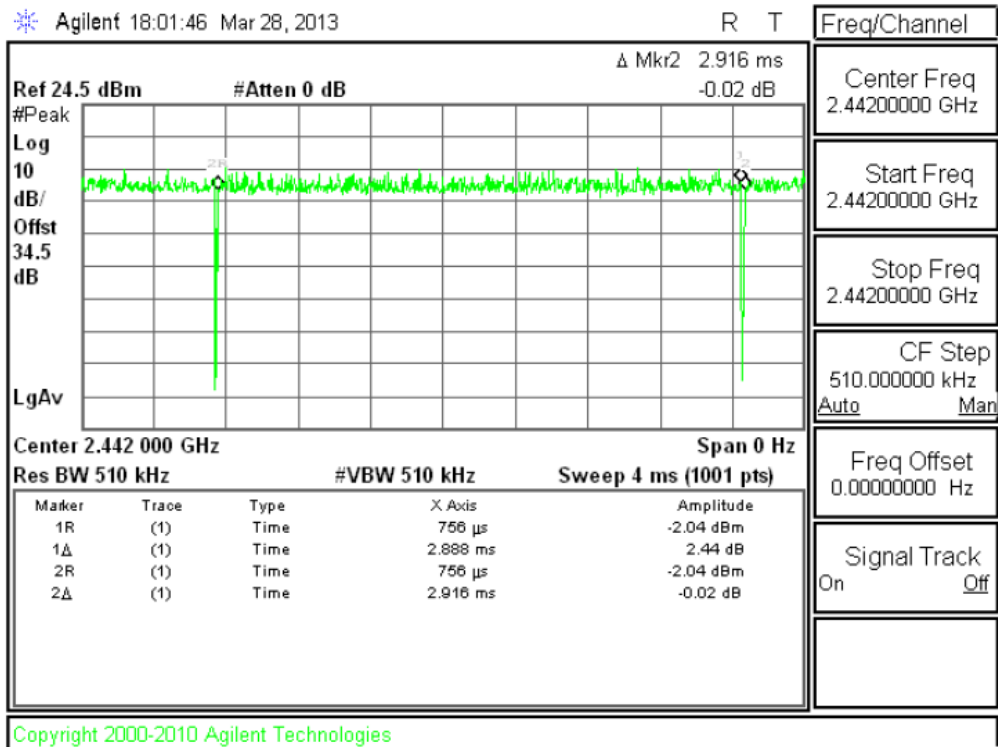

802.11n(HT40)

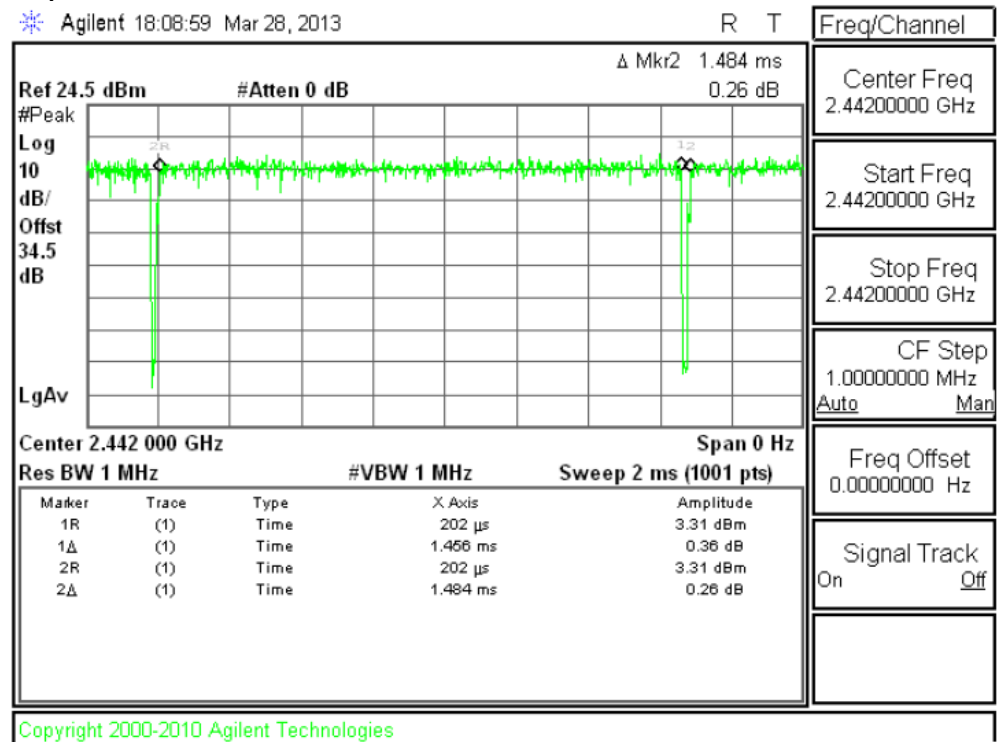





## **9.ANTENNA REQUIREMENT**

### **9.1 STANDARD REQUIREMENT**

15.203 requirement: For intentional device, according to 15.203: an intentional radiator shall be designed to ensure that no antenna other than that furnished by the responsible party shall be used with the device.

### **9.2 EUT ANTENNA**

The EUT antenna is Integrated(PCB) antenna. It comply with the standard requirement.

## 10. EUT TEST PHOTO

### Radiated Measurement Photos

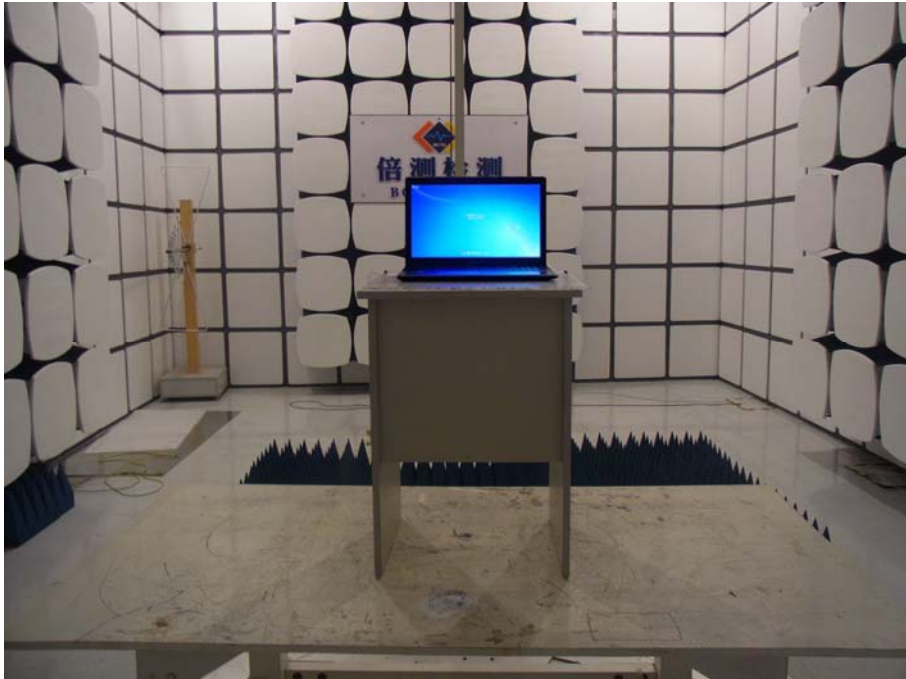
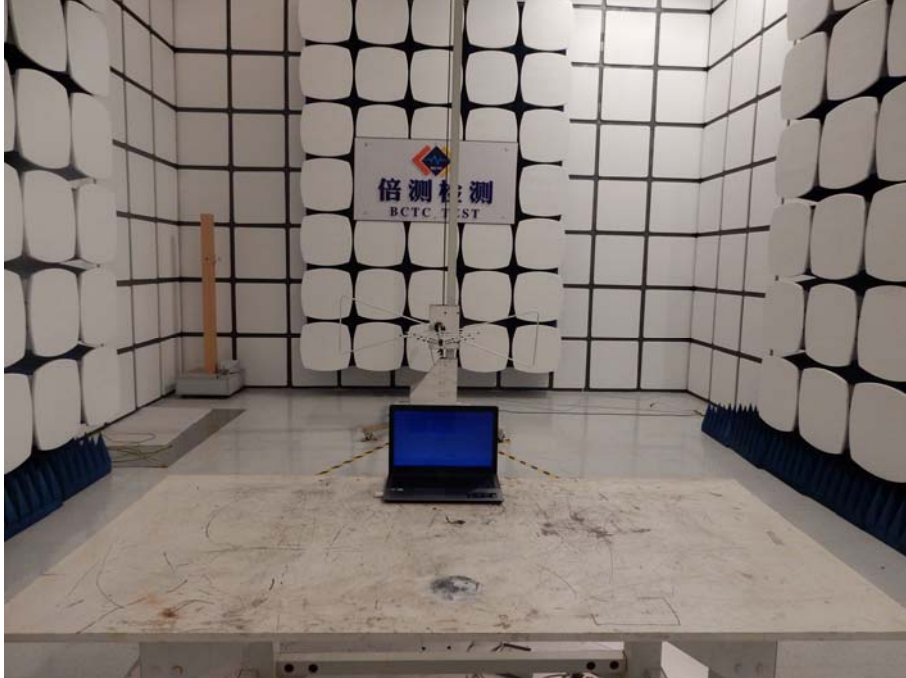



### Conducted Measurement Photos



### 11. EUT PHOTO



