

东莞市金赞智能科技有限公司

DONGGUAN KIMCHEN INDUSTRY INTL LIMITED



东莞市金赞智能科技有限公司

产品规格书

PRODUCT SPECIFICATION

客 户:	深圳市倍力奇科技有限公司
CUSTOMER:	_____
客户料号:	_____
CUST P/N:	_____
金赞料号:	_____
K C P/N:	_____
产品型号:	20.5*38*0.08*24P*2P*10TS*30MM
D E S E :	_____
日 期:	2023.6.15
D A T E :	_____
版 本:	A.0
VERSION :	_____

(客户承认受领印) ACCEPTANCE STAMP

拟制 PREPARED BY	跟单员 MERCHANDISER	工程审核 ENGINEER CHECKED BY	制程审核 PRODUCTION CHECKDED BY	批准 APPROVED BY
王云帆				

Address: 东莞市石碣镇西沙路 2 号 Tel: 86-076986018114 Fax: 86-076986015646

Http://www.jzcoil.com

文件编号 FilNo: KC-JZ-09-008

东莞市金赞智能科技有限公司

DONGGUAN KIMCHEN INDUSTRY INTL LIMITED

规格内容 Specification	客户料号: CUST P/N	20.5*38*0.08*24P*2P*10TS*30MM
	金赞型号: KC DESE	

	版本变更履历 Version Change History	变更后内容 DESCRIPTION (Content Or Reason For Changed)	日期 Date	修订者 Revisor
A.0	--	新发行 (Initial Release)	2023/6/15	王云帆

拟制 PREPARED BY	工程审核 ENGINEER CHECKED BY	制程审核 PRODUCTION CHECKED BY
王云帆		

Address: 东莞市石碣镇西沙路 2 号 Tel: 86-076986018114 Fax: 86-076986015646

Http://www.jzcoil.com 文件编号 FilNo: KC-JZ-09-008

东莞市金赞智能科技有限公司

DONGGUAN KIMCHEN INDUSTRY INTL LIMITED

规格内容		客户料号: CUST P/N		
Specification		金赞型号: KC DESE	20.5*38*0.08*24P*2P*10TS*30MM	

1. 产品外形尺寸 (OVERALL DIMENSIONS OF PRODUCTS):

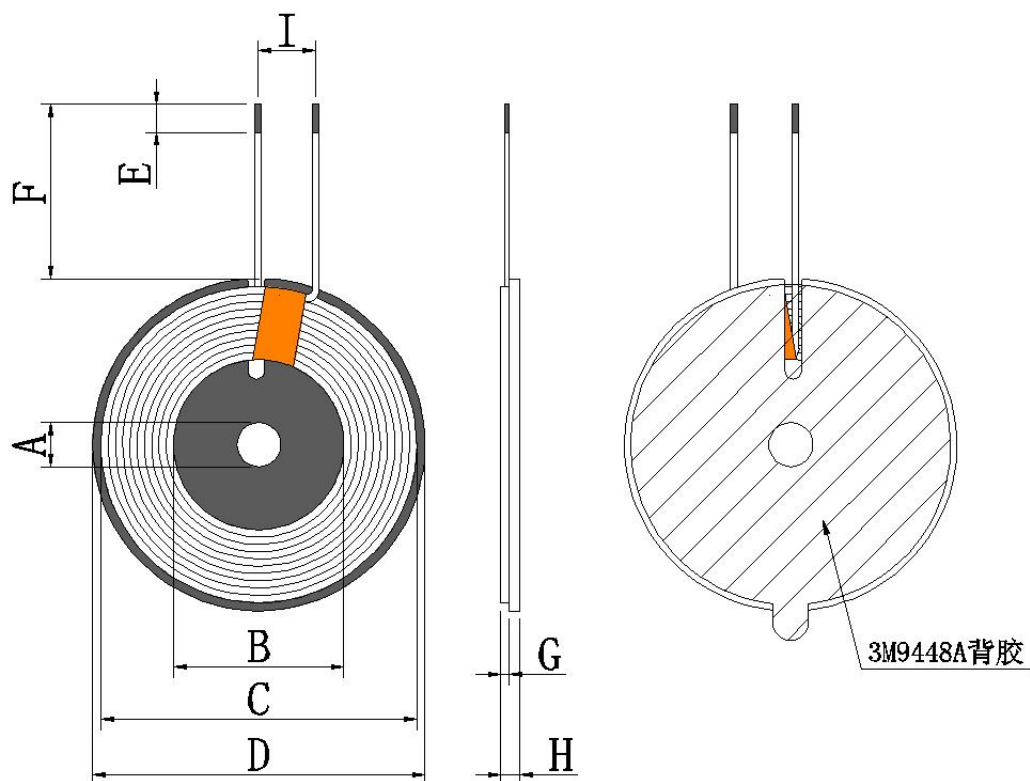

单位(Unit):毫米(mm)

A	B	C	D	E	F	G	H	I
5.3±0.5	20.5±0.5	38±1	40±1	3±1	30±1	0.5±0.05	2.0MAX	7±2

PS:1. (F) 为磁外引线长度; 2. (H) 包含进线, 不包含离型纸; 3. 引线间距: 5mm 胶布.

圈数 Turns	线径 Wire Dia.	绕线方式 疏/密 Wdg. Type Spred/Close	绕线方向 Wdg. Direction	相交 是/否 Intersect Yes/Not	线圈 正/反贴 Coil Positive/Anti Paste
10TS	0.08*24P*2P 热风绞线 (Stranded wire)	密绕 (Close)	逆时针 (Anticlockwise)	是 (Yes)	反贴 (Anti-/Paste)

拟制 PREPARED BY	工程审核 ENGINEER CHECKED BY	制程审核 PRODUCTION CHECKED BY
王云帆	胡志军	王云帆

Address: 东莞市石碣镇西沙路 2 号

Tel: 86-076986018114

Fax: 86-076986015646

Http://www.jzcoil.com

文件编号 FilNo: KC-JZ-09-008

东莞市金赞智能科技有限公司

DONGGUAN KIMCHEN INDUSTRY INTL LIMITED

规格内容
Specification客户料号:
CUST P/N金赞型号:
KC DESE

20.5*38*0.08*24P*2P*10TS*30MM

所有材料要求合格 ROHS 标准

2. 电气特性 (ELECTRICAL CHARACTERISTICS):

温度 TEMPERATURE: 25 ± 10°C, 湿度 RELATIVE HUMIDITY: 65 ± 10%

序号 NO.	项目 ITEM	端子 TERMINAL	标准 SPECIFICATION	测试条件 TEST FREQUENCY	测试仪器 TEST EQUIPMENTS
1	IND	S-F	线圈加磁片: 6.3 uH ± 10%	1kHz/V	LCZ METER 1062
2	Q 值	S-F	Q 值: 40MIN	1kHz/V	LCZ METER 1062

3. 材料清单 (BILL OF MATERIALS):

序号 NO.	材料名称 Material name	品名描述 Description	物料代码 Material Code	厂商代码 Vendor code
1	线材	0.08*24P*2P 热风绞线	JX-2U-F-0009	ZY
2	铁氧体	40 ± 1*5.3*0.8H ± 0.1 (带孔, 带 U 型直槽)	GCP-T-0088	LX
3	3M9448A 背胶	38.5*5.3*0.12H (带孔, 带手撕)		
4	金手指胶布	5mm	高温胶纸 5MM	JRM
5	胶水	JS-E7202 (加稠) 白胶	E7202W	HZY
6	锡条	环保无铅焊锡条	无铅高温锡条	XC

拟制
PREPARED BY

王云帆

工程审核
ENGINEER CHECKED BY

胡志军

制程审核
PRODUCTION CHECKED BY

王海燕

Address: 东莞市石碣镇西沙路 2 号

Tel: 86-076986018114

Fax: 86-076986015646

Http://www.jzcoil.com

文件编号 FilNo: KC-JZ-09-008