

Owner's Manual

RAPiD[®] VEHICLE SAFE

With patented RFID technology.



Item No. 98210



Instructional videos for Hornady Security[®]
products are available at hornady.com.



READ THIS FIRST

Warning: **NEVER** store a loaded firearm in the Hornady Security® RAPID® Vehicle Safe under any circumstances. The risks associated with storage of a loaded firearm include, but are not limited to, unintentional discharge upon insertion or removal of the firearm. Unintentional discharge may result in bullet and safe fragments dispersing in multiple directions, which may cause serious injury or death. Hornady Security® is not liable for any misuse of the RAPID® Safe.

Warning: No safe is entirely secure. The RAPID® Safe is only as secure as your maintenance of the keys, code and RFID tags. You are solely responsible for maintaining your keys, code, and RFID tags. Keep your keys and RFID tags in a secure location at all times. Store your RAPID® Safe in a secure location away from your keys and RFID tags. Hornady Security® is not liable for unauthorized access, including damage to, or loss of property, or personal injury. Again, **NEVER** store a loaded firearm in your Hornady® RAPID® Safe, as this may result in unauthorized access to the loaded firearm.

Warning: Except as expressly provided in the RAPID® Safe Limited Warranty, Hornady Security® is not liable for any expense or damage associated with your inability to open the RAPID® Safe. Electronic systems may fail. Verify that the keys furnished operate the lock. Keep your keys in a secure location at all times. For your security, Hornady Security® **WILL NOT** send replacement keys.

Warning: Hornady Security® is not liable for any loss, theft, or damage to personal property. The RAPID® Safe is not intended to protect the contents from fire, water, humidity, or other environmental conditions. Do not, under any circumstances, return the RAPID® Safe to Hornady Security® with any personal property inside.

Important Information

- **RFID Tag refers to the chip in any of the RFID “keys” included with the RAPID® Safe (wristband, key fob or decals). You may also purchase additional RFID tags.**
- **For trouble-free operation of your RAPID® Safe, please read and understand all instructions before use.**
- **Questions? Call our tech line at 800-338-3220.**
- **Never store loaded firearms in the RAPID® Safe. Follow local laws for firearm storage.**

Table of Contents

	Page
Warnings and Important Information.....	1
Items Included.....	2
Setup and Operation.....	3
Installation.....	7
Warranty.....	9
Product Registration and Service.....	10
Frequently Asked Questions.....	10

Items included with your RAPiD® Safe

1. RAPiD® Vehicle Safe
2. One (1) RFID Adjustable Wristband (No. 98166)
3. Two (2) RFID Adhesive Decals (No. 98168)
4. One (1) RFID Key Fob Tag (No. 98167)
5. Two (2) Circular Barrel Keys
6. Security Cable
7. 12V Car Adapter Power Supply
(not pictured)



RAPiD® Vehicle Safe

Item No. 98210

Exterior: 12.0" x 6.4" x 2.2"

Interior: 7.5" x 5.6" x 1.7"

Power: 12 V 1.0A or four (4) AAA
batteries *(not included)*

U.S. Patent No. 9530266

Not Pictured:

- Owner's Manual
- Warranty Card

RAPiD® Safe Setup and Operation

Congratulations on purchasing the technologically advanced RAPiD® Safe. You have taken a significant step in securing the safety of your handgun.

To achieve the best experience with your RAPiD® Safe, please read all instructions carefully, and understand its operation.

After the RAPiD® Safe has been taken out of the box, make sure both circular barrel keys fit and unlock your RAPiD® Safe. Contact Hornady® at 800-338-3220 if the keys do not work. Store keys in a secure location outside the safe.

AC Power

The RAPiD® Vehicle Safe is designed to be powered by either the 12V Car Adapter or four AAA batteries.

To connect the 12V Car Adapter, plug one end of the cable into your car's 12V accessory socket. Then, carefully run the cable behind the safe and through the channel in the back of the safe and plug the cable into the power jack.



Batteries

For backup or mobile use, your safe requires four AAA batteries (not included).

To install batteries, press the release tab on the side of the safe while lifting off the battery cover. Install four AAA batteries according to the diagram inside the battery compartment. Replace the battery cover by inserting the end opposite the release tab and then snapping it into place. Only use new high-quality AAA batteries. Replace all batteries at the same time.

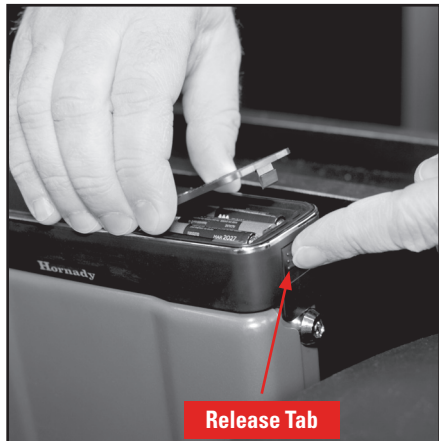

To check battery level:

1. Disconnect from the 12V Car Adapter.
2. Press any button on the keypad.
3. The LED light near the center of the keypad will flash.
 - a. Flashing Green – Good battery
 - b. Flashing Yellow – Low battery
 - c. Flashing Red – Weak battery

NOTE: Replace batteries every 12 months or if they become low or weak.

Battery Power Mode

When the RAPiD® Safe is unplugged and is operating on battery power, you must press any button on the keypad on the top panel to activate the RFID reader.

Pressing any button on the keypad causes the system to go from battery-saving mode to ready status.

For example: To open your safe with an RFID tag while the system is running on battery power, first press any button on the keypad to bring it to ready status. Place your RFID tag within 1" of the center of the RFID reader to open the safe.

Keypad Tones On/Off

Press and hold the "H" button on the keypad for 5 seconds until the light turns off to toggle sound on and off.

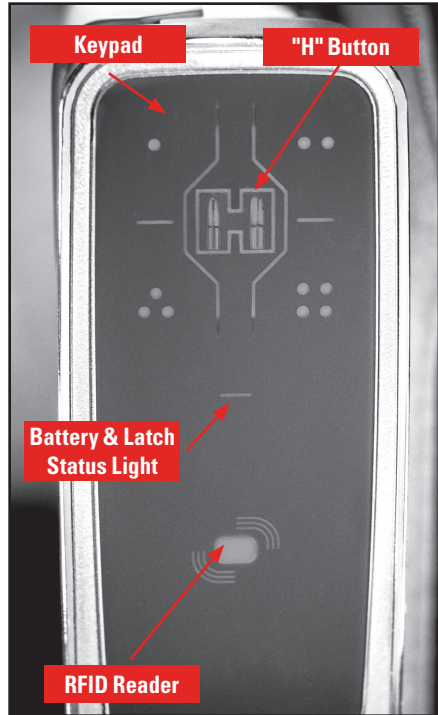

How to Program Your RFID Tags

Your RAPiD® Safe includes three (3) styles of RFID tags, including:

- 1 Adjustable Wristband
- 1 Key Fob
- 2 Decals

**Additional RFID tags can be purchased separately.*

The RAPiD® Safe can store up to 5 tags. To program these tags:

1. Open the RAPiD Safe with either the key, an RFID tag previously programmed by the user or the key code. *(The safe does not ship with pre-programmed RFID tags. An RFID tag must be programmed by the user to work with this safe.)*
2. Locate the red program button. Press and release the button to begin programming an RFID tag. The first available program location will begin to blink.
3. **Hold the RFID tag no more than 1-inch** from the illuminated RFID reader in the center of the top panel. If the programming was successful, the safe should beep two times and the available slot should go from blinking to solid red for approximately 10 seconds.

NOTE: *If the user attempts to program an RFID tag that is already stored into the safe, the safe will beep three times and the RFID tag will not be programmed into the duplicate slot. The RFID tag can only be programmed into one location.*

4. Verify the RFID tag is programmed by holding the tag over the RFID reader with the safe open. The motor should cycle after each scan.
5. If the RFID tag does not program into the safe, the program function will time out after 10 seconds and the safe will return to normal operation. If multiple attempts



NOTE: *The RFID chip is located in the bulge of the wristband near the clasp. It is designed to be worn on the bottom of the wrist for maximum read distance.*



to program an RFID tag fail, please contact Hornady at 800-338-3220.a

6. One to five RFID tags can be programmed into the safe.

WARNING: *After programming, confirm all RFID tags are either programmed or not. All programmed RFID tags must be kept in a safe place to prevent use from unauthorized users.*

How to Program Your Key Code

A single user-defined 4 to 6 digit code can be programmed into the RAPiD® Safe.

1. Open the RAPiD Safe with either the key or a previously programmed RFID tag or key code. The safe ships with a default code and should be reprogrammed before first use.
2. Locate the red program button to begin programming your key code. The first available tag location will begin to blink to indicate program mode.
3. With the safe open, enter a 4- to 6-digit code into the keypad. Press the “H” after entering your code. Verify your code is correct by re-entering your code and pressing “H.” The motor should cycle.



4. Your key code can now be used to open the safe.

NOTE: Only one key code can be programmed into the safe. If you attempt to program a second code, the previous code will be overwritten. **A total of 5 RFID tags and 1 key code can be programmed into the safe.**

How to Remove All RFID Tags From Safe

1. Open the RAPiD® Safe with either the key or a previously programmed RFID tag or key code. Locate the red program button. Press and hold the button for five seconds to erase all tags from the safe. All five red LEDs will begin to blink in sequence. (The safe does not allow individual tags to be removed. They must all be erased at one time. The intended RFID tags can then be reprogrammed back into the safe with the instructions above.)

NOTE: To abort the erase procedure, press the “H” button on the keypad, or

do not touch anything, and the erase procedure will automatically abort after 10 seconds and return to normal operation. **Test RFID tags and the key code to confirm they are operational.**

2. To confirm erasing procedure, press and release the program button again. All five LED lights will blink three times to visually confirm all RFID tags have been removed. All RFID tags will no longer work until they are programmed back into the safe with the instructions in the “How to Program Your RFID Tags” section.

Closing the Safe

The safe has a latch closure sensor that will illuminate the LED in the keypad when the lid is closed.

Green – Latch has fully closed.

Blinking Red – Latch has NOT fully closed.

Press lid to close or re-open and check for interference.

The vehicle mounting system includes a large mounting plate that can be wedged between the seat and center console or between two seats in the vehicle. The inflatable air bladder allows the mounting plate to adjust to nearly any seat gap and provide a firm mounting location for the Vehicle Safe without modifying the vehicle.

Installing the Vehicle Safe to the Mounting System

Determine if the Vehicle Safe will be placed on the driver or passenger side of the vehicle. Then loop the security cable around a solid anchor system near the desired mounting location. The seat frame is typically the most accessible anchor point.

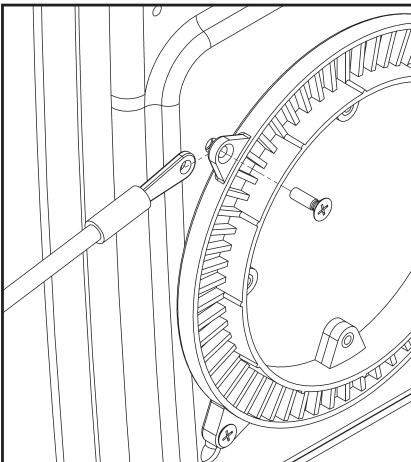
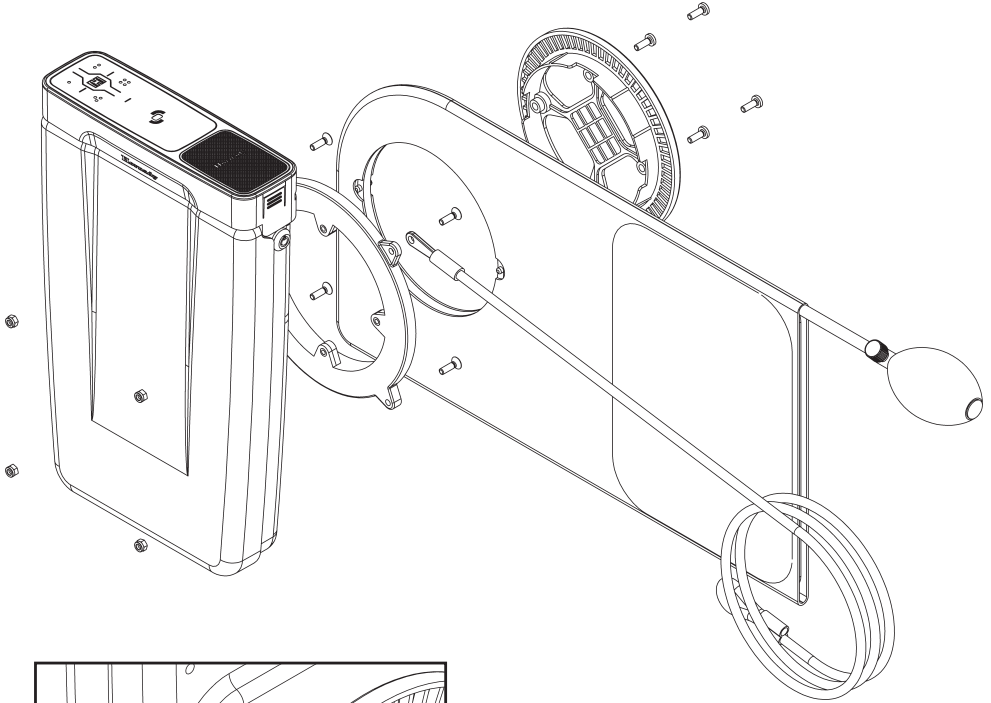

The Vehicle Safe attaches to the mounting plate using two clamping rings. The safe ships with one ring already attached to the back of the safe.

To attach the security cable, remove the one bolt and nut on the clamp ring near the mounting post with a gap. Place eye of cable ferrule between the safe and clamp ring and replace bolt and nut.

The mounting plate is designed to wedge between the seat and center console. The inflatable bladder is meant to take up the space between the seat and mounting plate so the mounting plate is held firmly against the center console.

- Verify the air bladder is positioned onto the mounting plate so it will inflate against the seat. It may need to be rotated around the mounting plate depending on if the safe will go on the driver or passenger side of the vehicle.
- To rotate the air bladder, release all air in the bladder by turning the control valve counterclockwise.
- Slide the fabric cover back to expose the air bladder on the mounting plate. Rotate the air bladder around the mounting plate until the inflatable air bladder is on the correct side.
- Slide fabric cover back over the air bladder.
- Begin by verifying the inflatable bladder is on the seat side of the mounting plate by closing the valve on the hand pump and gently inflating the air bladder.

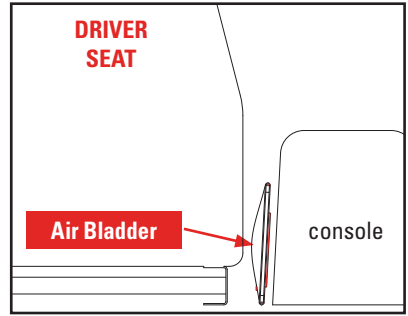
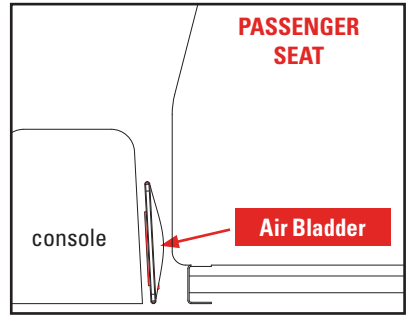

Install the safe onto the mounting plate by aligning the two clamp rings with the pins on the mounting plate and tighten the four screws.

NOTE: The safe can be tilted forward or back by adjusting the clamp rings **BEFORE** installing the screws.

Once the safe is mounted, slide the mounting plate between the seat and center console. Make sure the door of the safe can open without interfering with the seat.

Inflate the air bladder by turning the control valve clockwise and then squeezing the inflator bulb until the mounting system is firmly in place.

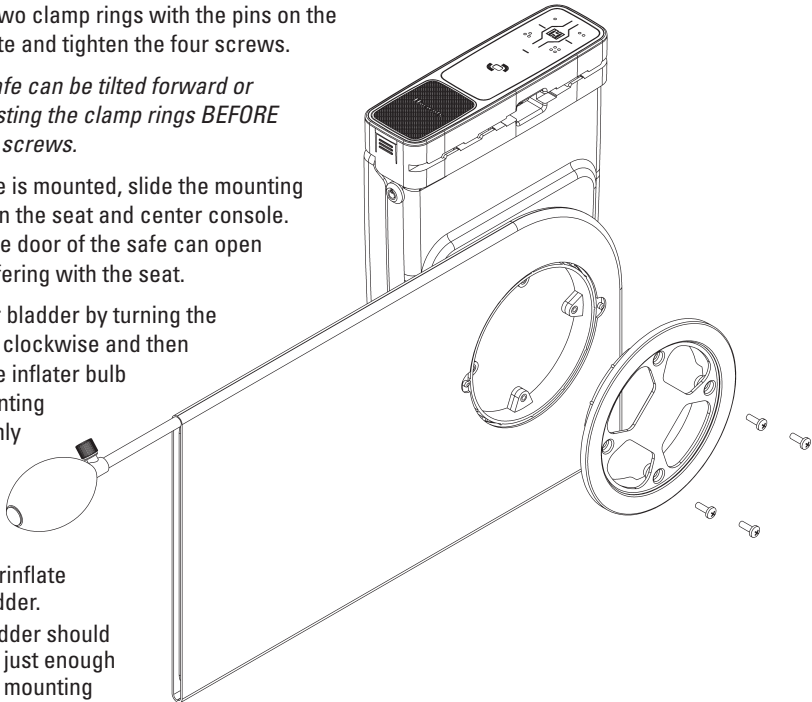

WARNING:

- Do not overinflate the air bladder.
- The air bladder should be inflated just enough to hold the mounting system in place.
- Make sure the mounting system does not move even during hard braking by testing in a controlled environment.

Verify system works as expected before storing a firearm or other valuables inside the safe.

RAPiD® Safe Limited Warranty

Hornady Security® warrants the RAPiD® Safe will, in normal use and service, be free from defects in workmanship or materials for one (1) year from date of purchase.

This Limited Warranty does not cover any of the following:

- (a) Damage, deterioration, or malfunction resulting from accident, negligence, misuse, improper installation, or lack of maintenance;
- (b) Any defects not discovered and reported to Hornady Security® during the one (1) year warranty period;
- (c) Usual and customary deterioration or wear resulting from normal use.

This Limited Warranty is not transferable and is enforceable by the original owner only. In the event that Hornady Security® receives notice from the original purchase of a warranty claim in conformity herewith, Hornady Security® will promptly undertake an investigation of such claim. If the warranty claim is covered by the Limited Warranty, Hornady Security®, will, in its sole discretion, repair the defect(s) or replace RAPiD® Safe at the expense of Hornady Security®.

Disclaimer of Implied Warranties. EXCEPT AS IS OTHERWISE EXPRESSLY SET FORTH IN THE ABOVE LIMITED WARRANTY, HORNADY SECURITY® MAKES NO OTHER REPRESENTATIONS OR WARRANTIES OF ANY KIND, WHETHER EXPRESSED OR IMPLIED, BY OPERATION OF LAW OR OTHERWISE WITH RESPECT TO THE RAPiD® SAFE OR ANY COMPONENT PART THEREOF, INCLUDING WITHOUT LIMITATION ANY REPRESENTATION OR WARRANTY WITH RESPECT TO MERCHANTABILITY OR FITNESS FOR ANY PARTICULAR PURPOSE OR USE.

Limitation on Liability. THE OBLIGATION OF HORNADY SECURITY® TO REPAIR OR REPLACE AS PROVIDED ABOVE SHALL BE THE SOLE AND ONLY REMEDY RESPECTING ANY DEFECT IN THE RAPiD® SAFE, OR ANY COMPONENT PART THEREOF. IN THE EVENT THAT THE FOREGOING REMEDY FAILS OF ITS ESSENTIAL PURPOSE, THE LIABILITY OF HORNADY SECURITY® TO PURCHASER SHALL NOT, IN ANY EVENT, EXCEED THE ACTUAL PURCHASE PRICE OF THE NON-CONFORMING GOODS; AND

Limitation on the Nature of Damages. HORNADY SECURITY® SHALL NOT, UNDER ANY CIRCUMSTANCES, BE LIABLE TO THE PURCHASER OR ANY THIRD PARTY FOR ANY SPECIAL, INDIRECT, INCIDENTAL, CONSEQUENTIAL, LIQUIDATED OR PUNITIVE DAMAGES OF ANY NAME, NATURE OR DESCRIPTION. HORNADY SECURITY® IS NOT RESPONSIBLE FOR DAMAGE TO OR THEFT OF THE RAPiD® SAFE, OR ITS CONTENTS.

Product Registration and Service

You must register your RAPiD® Safe in order to obtain Warranty Service. Simply complete and return the enclosed product registration card or submit through our website by going to hornady.com/warranties.

To Receive Warranty Service

In order to report a warranty claim, call Hornady Security® at 800-338-3220 to request a return authorization number. Returns will not be accepted without prior return authorization by Hornady Security®. When a return authorization number has been obtained, be sure all contents have been removed from the RAPiD® Safe before sending it for service. Hornady Security® is not liable for any loss, theft, or damage to personal property.

Post-Warranty Service Information

For issues concerning service after the Limited Warranty expires, contact Hornady Security® at 800-338-3220.

Frequently Asked Questions

I've lost my keys. Can I get a replacement?

For security reasons, Hornady® **WILL NOT** provide replacement barrel keys for the RAPiD® Safe. Consult a locksmith if needed.

Where can I find the serial number?

The serial number is located on the back of the safe. Prior to mounting the safe, record the serial number for future reference.

How long should the batteries last?

Quality batteries should last approximately 12 months, depending on use.

How do I return my RAPiD® Safe for warranty work?

Call Hornady® at 800-338-3220 and one of our technicians will assist you.

Why isn't my RFID wristband, key fob, or decals opening the safe?

- Be sure the RFID tag is programmed to your safe. The RAPiD® Safe allows five (5) RFID tags to be programmed for use.
- Check the power source. If the unit is plugged into an electrical outlet, the green LED light should be on. If the unit is on battery power, press the button on the top of the safe to bring the system to ready before placing the RFID tag on the reader.



This is a California-approved firearms safety device that meets the requirements of California Penal Code Section 12088 and the regulations issued thereunder.

This product has been tested and certified to conform to ASTM F2456, Youth Resistant Firearms Container.

FCC STATEMENT

1. This device complies with Part 15 of the FCC Rules. Operation is subject to the following two conditions:

- (1) This device may not cause harmful interference, and
- (2) This device must accept any interference received, including interference that may cause undesired operation.

2. Changes or modifications not expressly approved by the party responsible for compliance could void the user's authority to operate the equipment.

This equipment has been tested and found to comply with the limits for a Class B digital device, pursuant to part 15 of the FCC Rules. These limits are designed to provide reasonable protection against harmful interference in a residential installation. This equipment generates, uses and can radiate radio frequency energy and, if not installed and used in accordance with the instructions, may cause harmful interference to radio communications. However, there is no guarantee that interference will not occur in a particular installation. If this equipment does cause harmful interference to radio or television reception, which can be determined by turning the equipment off and on, the user is encouraged to try to correct the interference by one or more of the following measures:

- Reorient or relocate the receiving antenna.
- Increase the separation between the equipment and receiver.
- Connect the equipment into an outlet on a circuit different from that to which the receiver is connected.
- Consult the dealer or an experienced radio/ TV technician for help.



P.O. Box 1848, Grand Island, Nebraska 68802-1848
308-382-1390 • 800-338-3220 • Fax: 308-382-5761
www.hornady.com • Hornady.com/contact_us