



FCC Part 15B Test Report

FCC ID:2AFJI-B4L0TI

Applicant: QUANTUM CREATIONS, LLC

Address: 15705 NW 13th Ave Miami Gardens, FL 33169, United States

Manufacturer: QUTHC Limited

Address: 7th Floor, Building C, Longsheng Industrial Park, No.11 of Qiuchang Xihu Village, Huiyang District, Huizhou City, Guangdong province (516211) P.R.China

EUT: Byte4 Elite/ Emerald

Trade Mark: AZULLE/Simply NUC/Raydiant

Model Number: BT7003
BT5003, BT3003, NUC11EMi3, NUC11EMi5, NUC11EMi7

Date of Receipt: Mar. 01, 2023

Test Date: Mar. 01, 2023 – Mar. 07, 2023

Date of Report: Mar. 07, 2023

Prepared By: Shenzhen DL Testing Technology Co., Ltd.

Address: 101-201, Building C, Shuanghuan, No.8, Baoqing Road, Baolong Industrial Zone, Baolong Street, Longgang District, Shenzhen, Guangdong, China

Applicable Standards: FCC PART 15 B
ANSI C63.4:2014

Test Result: Pass

Report Number: DL-20230307025E

Prepared (Test Engineer): Pxing Huang

Reviewer (Supervisor): Jack Bu

Approved (Manager): Jade Yang



This test report is based on a single evaluation of one sample of above mentioned products. It is not permitted to be duplicated in extracts without written approval of Shenzhen DL Testing Technology Co., Ltd.



Table of Contents	Page
1 . SUMMARY OF TEST RESULTS	3
1.1 MEASUREMENT UNCERTAINTY	3
2 . GENERAL INFORMATION	4
2.1 GENERAL DESCRIPTION OF EUT	4
2.2 DESCRIPTION OF TEST MODES	5
2.3 BLOCK DIGRAM SHOWING THE CONFIGURATION OF SYSTEM TESTED	5
2.4 DESCRIPTION OF SUPPORT UNITS(CONDUCTED MODE)	6
2.5 EQUIPMENTS LIST FOR ALL TEST ITEMS	7
3 . EMC EMISSION TEST	8
3.1 CONDUCTED EMISSION MEASUREMENT	8
3.1.1 POWER LINE CONDUCTED EMISSION LIMITS	8
3.1.2 TEST PROCEDURE	8
3.1.3 DEVIATION FROM TEST STANDARD	8
3.1.4 TEST SETUP	9
3.1.5 EUT OPERATING CONDITIONS	9
3.1.6 TEST RESULTS	9
3.2 RADIATED EMISSION MEASUREMENT	12
3.2.1 RADIATED EMISSION LIMITS	12
3.2.2 TEST PROCEDURE	12
3.2.3 DEVIATION FROM TEST STANDARD	13
3.2.4 TEST SETUP	13
3.2.5 EUT OPERATING CONDITIONS	14
3.2.6 TEST RESULTS (BETWEEN 30MHZ – 1GHZ)	15
3.2.7 TEST RESULTS (1GHZ~40GHZ)	17
4 . TEST SEUUP PHOTO	19
5 . EUT PHOTO	21



1. SUMMARY OF TEST RESULTS

Test procedures according to the technical standards:

FCC Part15 , Subpart B			
Standard Section	Test Item	Judgment	Remark
15.107	Conducted Emission	PASS	
15.109	Radiated Emission	PASS	

NOTE:

- (1) "N/A" denotes test is not applicable in this Test Report
- (2) the The internal module of the product has obtained FCC ID certification, and the FCC ID number is: PD9AX201D2.

1.1 MEASUREMENT UNCERTAINTY

The reported uncertainty of measurement $y \pm U$, where expended uncertainty U is based on a standard uncertainty multiplied by a coverage factor of $k=2$ providing a level of confidence of approximately 95 %.

No.	Item	Uncertainty
1	Conducted Emission Test	$\pm 2.56\text{dB}$
2	RF power,conducted	$\pm 0.42\text{dB}$
3	Spurious emissions,conducted	$\pm 2.76\text{dB}$
4	All emissions,radiated(30MHz-1G)	$\pm 3.65\text{dB}$
5	All emissions,radiated(9kHz-30MHz)	$\pm 3.66\text{dB}$
6	All emissions,radiated(>1G)	$\pm 4.89\text{dB}$
7	Temperature	$\pm 0.5^\circ\text{C}$
8	Humidity	$\pm 2\%$



2. GENERAL INFORMATION

2.1 GENERAL DESCRIPTION OF EUT

Product Name:	Byte4 Elite/ Emerald
Trademark	AZULLE/Simply NUC/Raydiant
Model No.:	BT7003 BT5003, BT3003, NUC11EMi3, NUC11EMi5, NUC11EMi7
Model Difference	All the models are electrical identical including the same software parameter and hardware design (circuit design, PCB Layout, RF module/circuit, antenna type(s) and antenna location, components on PCB,) the only difference is the model name, Shell top pattern
Max Operation Frequency	5.8GHz
Antenna Type:	External antenna*2
Antenna gain:	2dBi MIMO Gain=2dBi+10log(2)=5.01dBi
Power supply:	DC 19V from adapter
Adapter:	Model: FJ-SW20171903000 Input: AC 100-240V 50/60Hz Output: DC 19.0V 3.0A 57.0W

Note:

- 1.For a more detailed features description, please refer to the manufacturer's specifications or the User's Manual.
- 2.The EUT's all information provided by client.



2.2 DESCRIPTION OF TEST MODES

To investigate the maximum EMI emission characteristics generates from EUT, the test system was pre-scanning tested base on the consideration of following EUT operation mode or test configuration mode which possible have effect on EMI emission level. Each of these EUT operation mode(s) or test configuration mode(s) mentioned above was evaluated respectively.

For conducted Emission			
Final test Mode			
Mode 1	System running		

For Radiated Emission			
Final test Mode			
Mode 1	System running		

2.3 BLOCK DIGRAM SHOWING THE CONFIGURATION OF SYSTEM TESTED

Emission Test

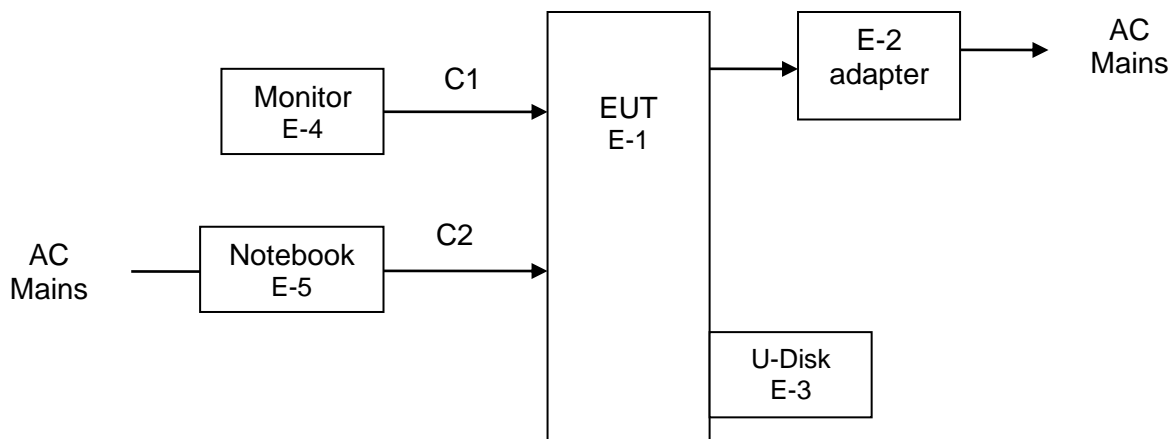



2.4 DESCRIPTION OF SUPPORT UNITS(CONDUCTED MODE)

The EUT has been tested as an independent unit together with other necessary accessories or support units. The following support units or accessories were used to form a representative test configuration during the tests.

Item	Equipment	Model/Type No.	Series No.	Note
E-1	Byte4 Elite/ Emerald	BT7003	N/A	EUT
E-2	adapter	FJ-SW20171903000	N/A	Provide by client.
E-3	U-disk(kingston)	18g	N/A	Provide by Lab
E-4	Monitor(Changhong)	32D3F	N/A	Provide by Lab
E-5	Notebook(LENOVO)	310S-14AST	N/A	Provide by Lab

Item	Shielded Type	Ferrite Core	Length	Note
C1	No	No	1.5m	HDMI line
C2	No	No	1.2m	RJ45

Note:

- (1) For detachable type I/O cable should be specified the length in cm in 『Length』 column.

**2.5 EQUIPMENTS LIST FOR ALL TEST ITEMS**

Radiation test, Band-edge test and 6db bandwidth test equipment

Item	Equipment	Manufacturer	Type No.	Serial No.	Last calibration	Calibrated until
1	Spectrum Analyzer (9kHz-26.5GHz)	Agilent	E4408B	MY50140780	Nov. 05, 2022	Nov. 04, 2023
2	Test Receiver (9kHz-7GHz)	R&S	ESRP7	101393	Nov. 05, 2022	Nov. 04, 2023
3	Bilog Antenna (30MHz-1GHz)	R&S	VULB9162	00306	Nov. 05, 2022	Nov. 04, 2023
4	Horn Antenna (1GHz-18GHz)	Schwarzbeck	BBHA9120D	02139	Nov. 05, 2022	Nov. 04, 2023
5	Horn Antenna (18GHz-40GHz)	A.H. Systems	SAS-574	588	Nov. 05, 2022	Nov. 04, 2023
6	Amplifier (9KHz-6GHz)	Schwarzbeck	BBV9743B	00153	Nov. 05, 2022	Nov. 04, 2023
7	Amplifier (1GHz-18GHz)	EMEC	EM01G8GA	00270	Nov. 05, 2022	Nov. 04, 2023
8	Amplifier (18GHz-40GHz)	Quanjuda	DLE-161	97	Nov. 05, 2022	Nov. 04, 2023
9	Loop Antenna (9KHz-30MHz)	Schwarzbeck	FMZB1519B	00014	Nov. 05, 2022	Nov. 04, 2023
10	RF cables1 (9kHz-1GHz)	ChengYu	966	004	Nov. 05, 2022	Nov. 04, 2023
11	RF cables2 (1GHz-40GHz)	ChengYu	966	003	Nov. 05, 2022	Nov. 04, 2023
12	Antenna connector	Florida RF Labs	N/A	RF 01#	Nov. 05, 2022	Nov. 04, 2023
13	Power probe	KEYSIGHT	U2021XA	MY55210018	Nov. 05, 2022	Nov. 04, 2023
14	Signal Analyzer 9kHz-26.5GHz	Agilent	N9020A	MY55370280	Nov. 05, 2022	Nov. 04, 2023
15	Test Receiver 20kHz-40GHz	R&S	ESU 40	100376	Nov. 05, 2022	Nov. 04, 2023
16	D.C. Power Supply	LongWei	PS-305D	010964729	Nov. 05, 2022	Nov. 04, 2023

Conduction Test equipment

Item	Equipment	Manufacturer	Type No.	Serial No.	Last calibration	Calibrated until
1	843 Shielded Room	ChengYu	843 Room	843	Sep. 20, 2022	Sep. 19, 2025
2	EMI Receiver	R&S	ESR	101421	Nov. 05, 2022	Nov. 04, 2023
3	LISN	R&S	ENV216	102417	Nov. 05, 2022	Nov. 04, 2023
4	843 Cable 1#	ChengYu	CE Cable	001	Nov. 05, 2022	Nov. 04, 2023

Other

Item	Name	Manufacturer	Model	Software version
1	EMC Conduction Test System	FALA	EZ_EMCC	EMC-CON 3A1.1
2	EMC radiation test system	FALA	EZ_EMCC	FA-03A2
3	RF test system	MAIWEI	MTS8310	2.0.0.0
4	RF communication test system	MAIWEI	MTS8200	2.0.0.0



3. EMC EMISSION TEST

3.1 CONDUCTED EMISSION MEASUREMENT

3.1.1 POWER LINE CONDUCTED EMISSION Limits (Frequency Range 150KHz-30MHz)

FREQUENCY (MHz)	Limit (dBuV)		Standard
	Quasi-peak	Average	
0.15 -0.5	66 - 56 *	56 - 46 *	FCC
0.5 -5.0	56.00	46.00	FCC
5.0 -30.0	60.00	50.00	FCC

Note:

- (1) The tighter limit applies at the band edges.
- (2) The limit of " * " marked band means the limitation decreases linearly with the logarithm of the frequency in the range.

The following table is the setting of the receiver

Receiver Parameters	Setting
Attenuation	10 dB
Start Frequency	0.15 MHz
Stop Frequency	30 MHz
IF Bandwidth	9 kHz

3.1.2 TEST PROCEDURE

- a. The EUT was placed 0.8 meters from the horizontal ground plane with EUT being connected to the power mains through a line impedance stabilization network (LISN). All other support equipments powered from additional LISN(s). The LISN provide 50 Ohm/ 50uH of coupling impedance for the measuring instrument.
- b. Interconnecting cables that hang closer than 40 cm to the ground plane shall be folded back and forth in the center forming a bundle 30 to 40 cm long.
- c. I/O cables that are not connected to a peripheral shall be bundled in the center. The end of the cable may be terminated, if required, using the correct terminating impedance. The overall length shall not exceed 1 m.
- d. LISN at least 80 cm from nearest part of EUT chassis.
- e. For the actual test configuration, please refer to the related Item –EUT Test Photos.

3.1.3 DEVIATION FROM TEST STANDARD

No deviation

3.1.4 TEST SETUP

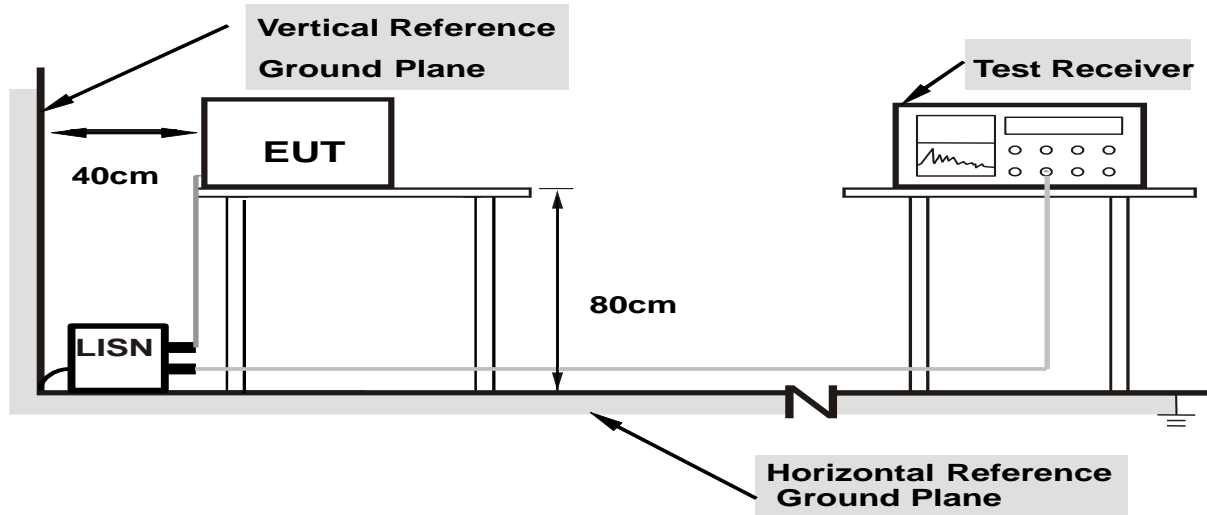

Note: 1.Support units were connected to second LISN.

2.Both of LISNs (AMN) are 80 cm from EUT and at least 80 from other units and other metal planes

3.1.5 EUT OPERATING CONDITIONS

The EUT was configured for testing in a typical fashion (as a customer would normally use it). The EUT has been programmed to continuously transmit during test. This operating condition was tested and used to collect the included data.

We pretest AC 120V and AC 230V, the worst voltage was AC 120V and the data recording in the report.

3.1.6 TEST RESULTS



Temperature:	25 °C	Relative Humidity:	54%
Pressure:	1010hPa	Phase :	L
Test Voltage :	AC 120V/60Hz	Test Mode:	Mode 1

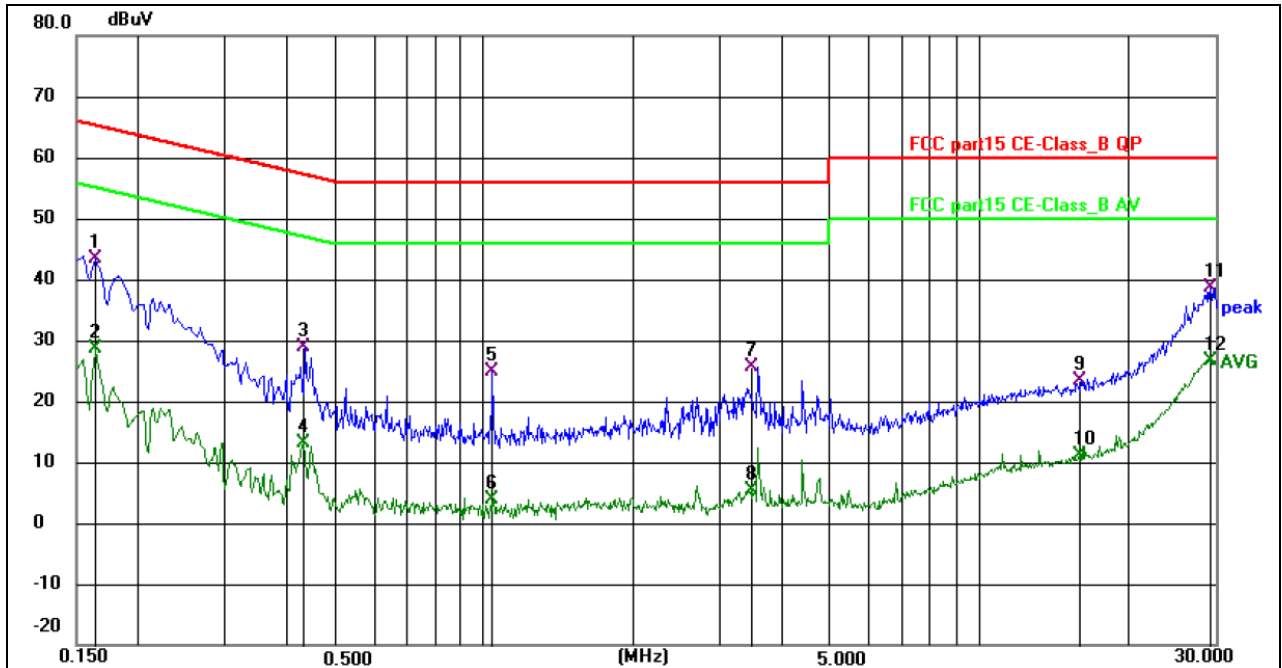

Remark:

Margin = Limit – Level, Correct Factor = Cable lose + LISN insertion loss, Level= Reading + Correct factor

No.	Frequency (MHz)	Reading (dBuV)	Factor (dB)	Level (dBuV)	Limit (dBuV)	Margin (dB)	Detector	P/F	Remark
1	0.163500	33.13	10.22	43.35	65.28	-21.93	QP	P	
2	0.163500	18.49	10.22	28.71	55.28	-26.57	AVG	P	
3	0.429000	19.83	9.15	28.98	57.27	-28.29	QP	P	
4	0.429000	4.10	9.15	13.25	47.27	-34.02	AVG	P	
5	1.041000	15.57	9.30	24.87	56.00	-31.13	QP	P	
6	1.041000	-5.39	9.30	3.91	46.00	-42.09	AVG	P	
7	3.471000	16.64	9.06	25.70	56.00	-30.30	QP	P	
8	3.471000	-3.76	9.06	5.30	46.00	-40.70	AVG	P	
9	15.940500	13.29	10.18	23.47	60.00	-36.53	QP	P	
10	15.940500	0.89	10.18	11.07	50.00	-38.93	AVG	P	
11 *	29.251500	27.63	10.93	38.56	60.00	-21.44	QP	P	
12	29.251500	15.71	10.93	26.64	50.00	-23.36	AVG	P	



Temperature:	25 °C	Relative Humidity:	54%
Pressure:	1010hPa	Phase :	N
Test Voltage :	AC 120V/60Hz	Test Mode:	Mode 1

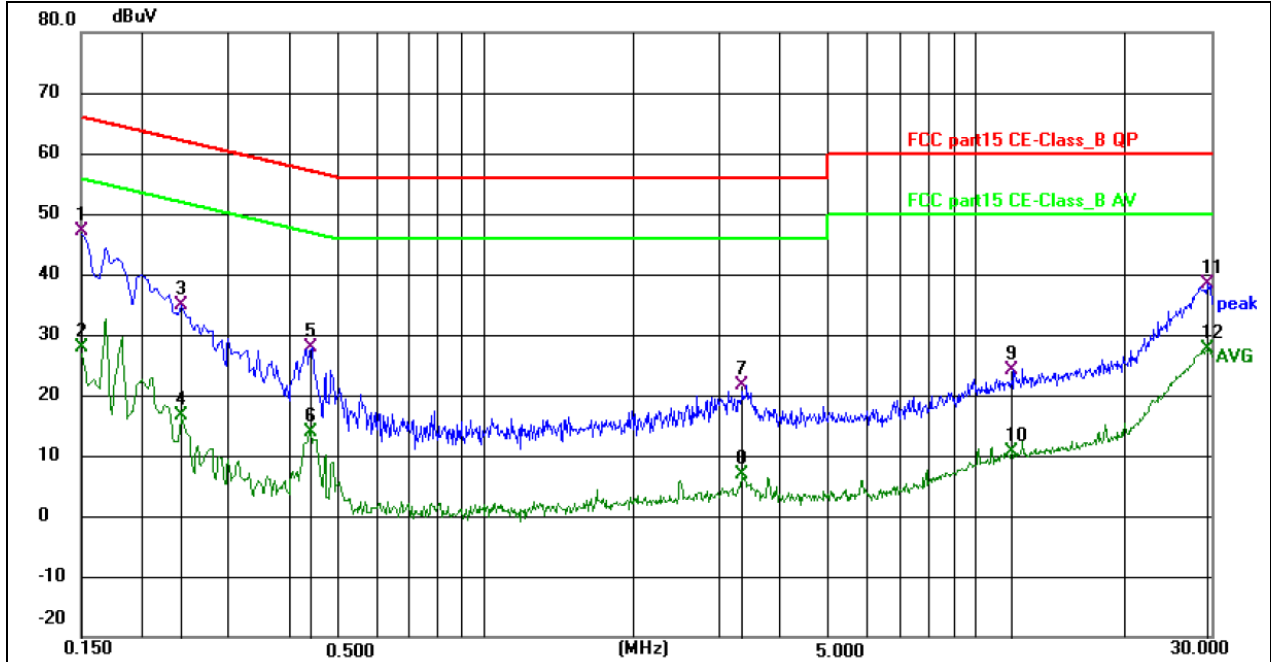

Remark:

Margin = Limit – Level, Correct Factor = Cable lose + LISN insertion loss, Level= Reading + Correct factor

No.	Frequency (MHz)	Reading (dBuV)	Factor (dB)	Level (dBuV)	Limit (dBuV)	Margin (dB)	Detector	P/F	Remark
1 *	0.150000	36.73	10.35	47.08	66.00	-18.92	QP	P	
2	0.150000	17.51	10.35	27.86	56.00	-28.14	AVG	P	
3	0.240000	26.03	8.94	34.97	62.10	-27.13	QP	P	
4	0.240000	7.77	8.94	16.71	52.10	-35.39	AVG	P	
5	0.438000	18.48	9.29	27.77	57.10	-29.33	QP	P	
6	0.438000	4.69	9.29	13.98	47.10	-33.12	AVG	P	
7	3.345000	11.74	9.82	21.56	56.00	-34.44	QP	P	
8	3.345000	-3.03	9.82	6.79	46.00	-39.21	AVG	P	
9	11.769000	14.09	10.14	24.23	60.00	-35.77	QP	P	
10	11.769000	0.56	10.14	10.70	50.00	-39.30	AVG	P	
11	29.607000	27.49	10.98	38.47	60.00	-21.53	QP	P	
12	29.607000	16.61	10.98	27.59	50.00	-22.41	AVG	P	



3.2 RADIATED EMISSION MEASUREMENT

3.2.1 RADIATED EMISSION LIMITS (Frequency Range 30MHz-1000MHz)

In case the emission fall within the restricted band specified on the 15.109 limit in the table below has to be followed.

Frequencies (MHz)	Field Strength (micorvolts/meter)	Measurement Distance (meters)
30~88	100	3
88~216	150	3
216~960	200	3
Above 960	500	3

LIMITS OF RADIATED EMISSION MEASUREMENT (Above 1000MHz)

FREQUENCY (MHz)	Limit (dBuV/m) (at 3M)	
	PEAK	AVERAGE
Above 1000	74	54

Notes:

- (1) The limit for radiated test was performed according to FCC PART 15B.
- (2) The tighter limit applies at the band edges.
- (3) Emission level (dBuV/m)=20log Emission level (uV/m).

Spectrum Parameter	Setting
Attenuation	Auto
Start Frequency	1000 MHz
Stop Frequency	6GHz
RB / VB (emission in restricted band)	1 MHz / 1 MHz for Peak, 1 MHz / 10Hz for Average

Receiver Parameter	Setting
Attenuation	Auto
Start ~ Stop Frequency	9kHz~150kHz / RB 200Hz for QP
Start ~ Stop Frequency	150kHz~30MHz / RB 9kHz for QP
Start ~ Stop Frequency	30MHz~1000MHz / RB 120kHz for QP

3.2.2 TEST PROCEDURE

Below 1GHz test procedure as below:

- a. The EUT was placed on the top of a rotating table 0.8 meters above the ground at a 3 meter semi-anechoic chamber. The table was rotated 360 degrees to determine the position of the highest radiation.
- b. The EUT was set 3 meters away from the interference-receiving antenna, which was mounted on the top of a variable-height antenna tower.

- c. The antenna height is varied from one meter to four meters above the ground to determine the maximum value of the field strength. Both horizontal and vertical polarizations of the antenna are set to make the measurement.
- d. For each suspected emission, the EUT was arranged to its worst case and then the antenna was tuned to heights from 1 meter to 4 meters (for the test frequency of below 30MHz, the antenna was tuned to heights 1 meter) and the rotatable table was turned from 0 degrees to 360 degrees to find the maximum reading.
- e. The test-receiver system was set to Peak Detect Function and Specified Bandwidth with Maximum Hold Mode.
- f. If the emission level of the EUT in peak mode was 10dB lower than the limit specified, then testing could be stopped and the peak values of the EUT would be reported. Otherwise the emissions that did not have 10dB margin would be re-tested one by one using peak, quasi-peak or average method as specified and then reported in a data sheet.

3.2.3 DEVIATION FROM TEST STANDARD

No deviation

3.2.4 TEST SETUP

(A) Radiated Emission Test-Up Frequency 30MHz~1GHz

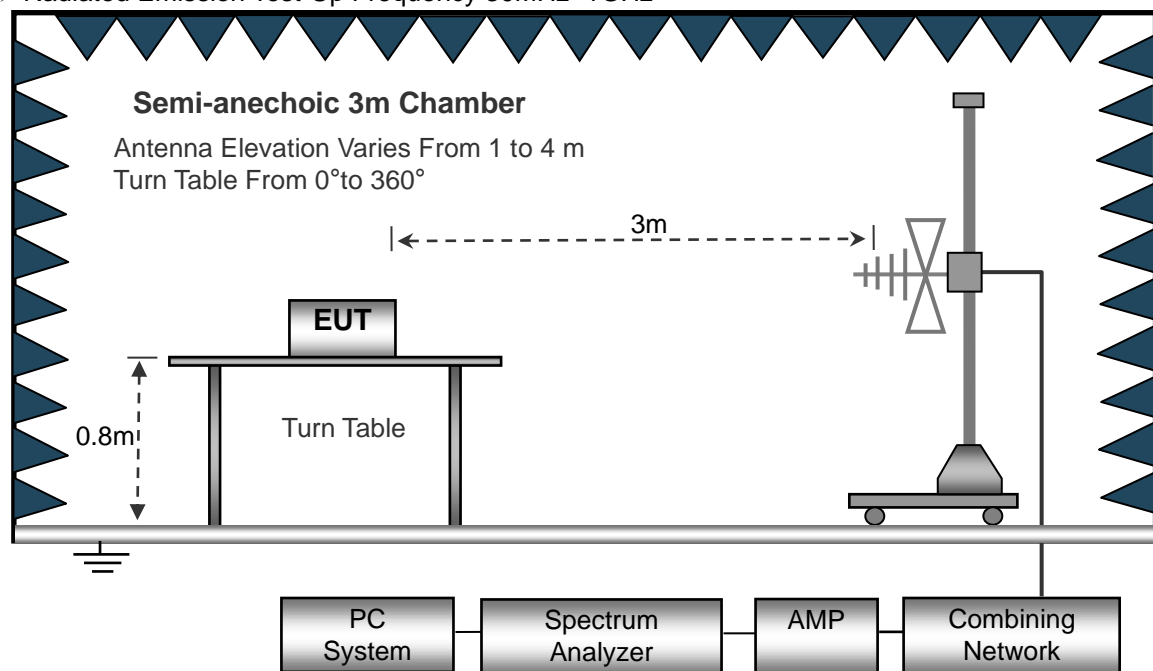

(B) Radiated Emission Test-Up Frequency Above 1GHz

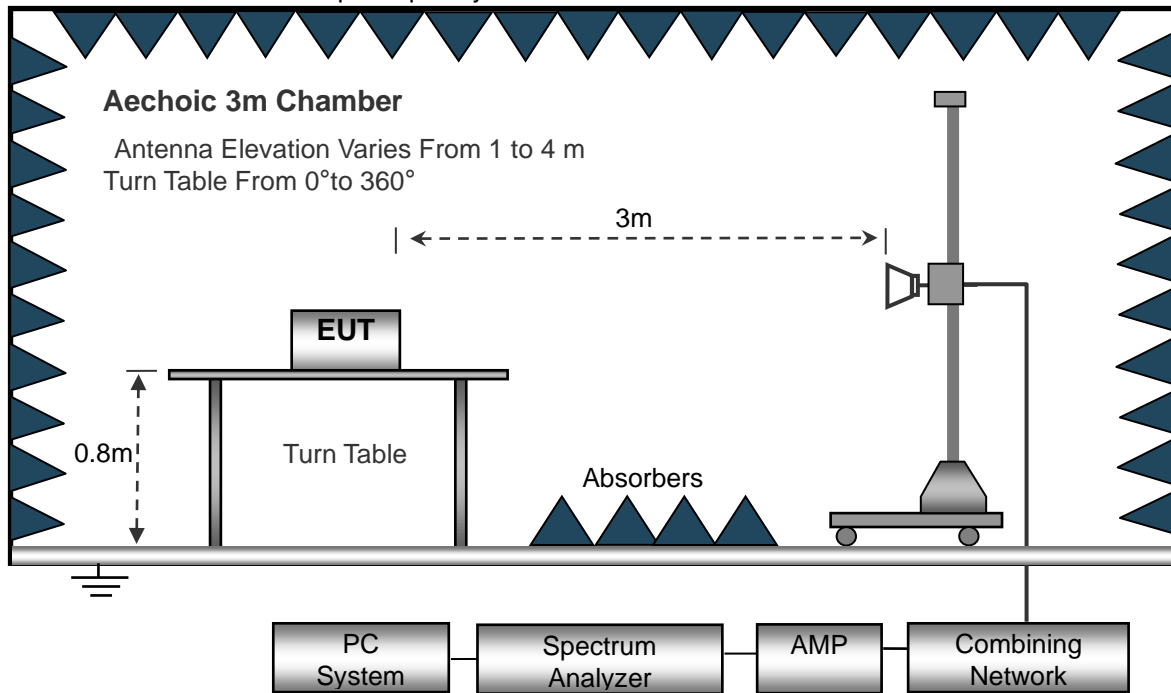

3.2.5 EUT OPERATING CONDITIONS

The EUT tested system was configured as the statements of 2.3 Unless otherwise a special operating condition is specified in the follows during the testing.



3.2.6 TEST RESULTS (Between 30MHz – 1GHz)

Temperature:	26°C	Relative Humidity:	54%
Pressure:	1010 hPa	Polarization :	Horizontal
Test Voltage :	AC 120V/60Hz		
Test Mode :	Mode 1		

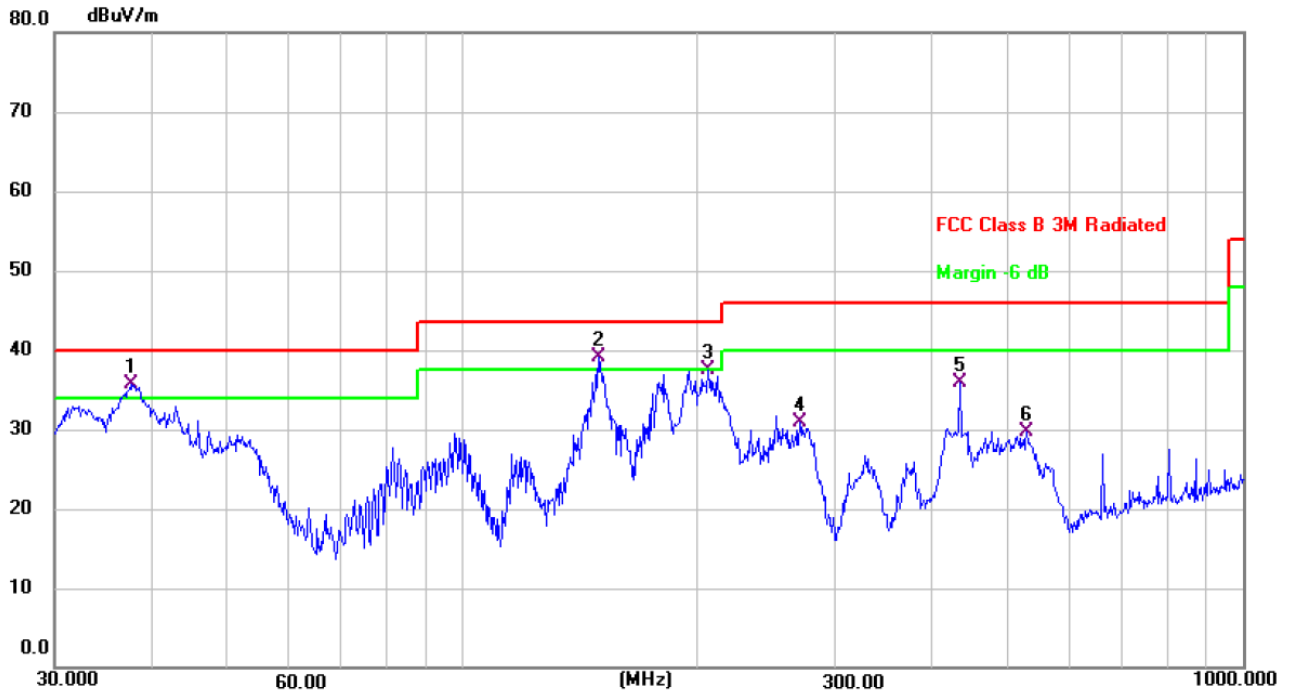

No.	Mk.	Freq. MHz	Reading Level dBuV	Correct Factor dB	Measure- ment dBuV/m	Limit dB/m	Margin dB	Detector
1	*	37.5479	48.75	-13.14	35.61	40.00	-4.39	QP
2	!	149.4857	55.56	-16.48	39.08	43.50	-4.42	QP
3		206.3976	50.16	-12.74	37.42	43.50	-6.08	QP
4		270.3748	41.38	-10.40	30.98	46.00	-15.02	QP
5		434.0651	43.34	-7.46	35.88	46.00	-10.12	QP
6		528.2458	35.24	-5.53	29.71	46.00	-16.29	QP

Remark:

Correct Factor = Cable loss + Antenna factor – Preamplifier;

Level = Reading Level + Correct Factor; Margin = Limit – Level;



Temperature:	26°C	Relative Humidity:	54%
Pressure:	1010 hPa	Polarization :	Vertical
test voltage :	AC 120V/60Hz		
Test Mode :	Mode 1		

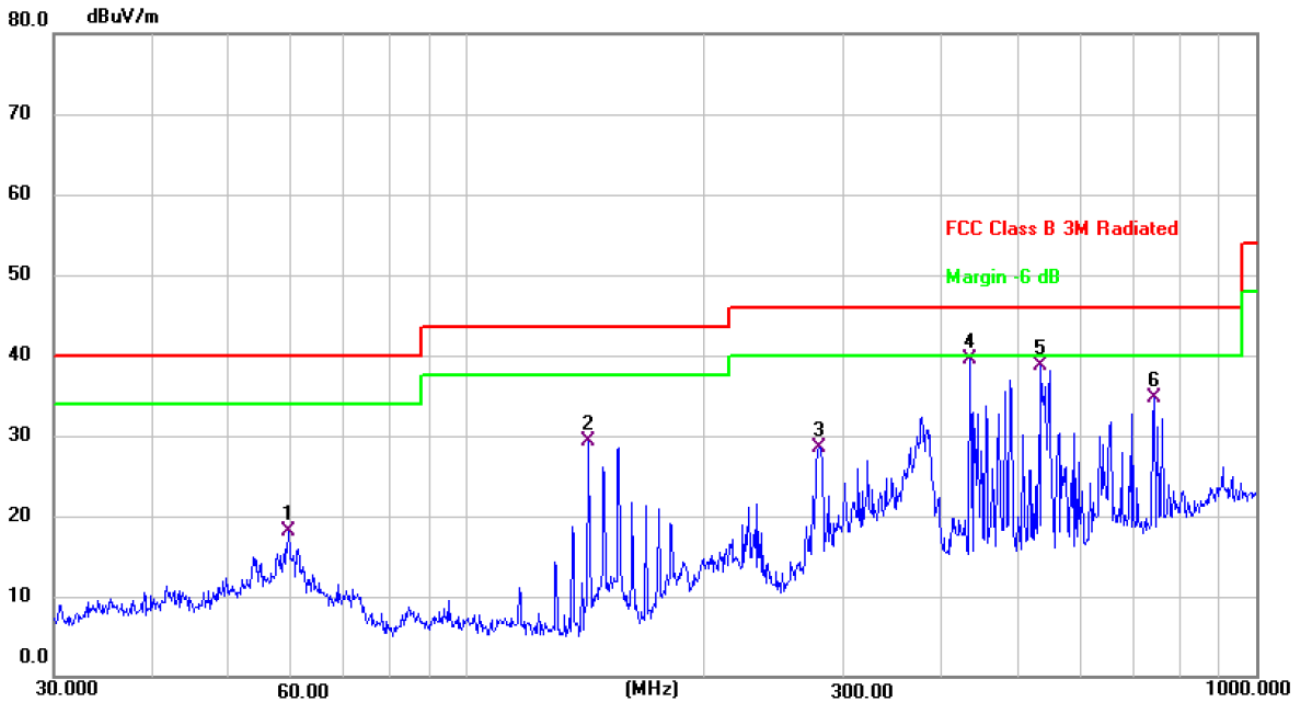

No.	Mk.	Freq. MHz	Reading Level dBuV	Correct Factor dB	Measure- ment dBuV/m	Limit dB/m	Margin dB	Detector
1		59.4405	29.28	-11.18	18.10	40.00	-21.90	QP
2		142.8243	45.44	-16.17	29.27	43.50	-14.23	QP
3		279.0436	39.68	-11.14	28.54	46.00	-17.46	QP
4	*	434.0651	47.83	-8.42	39.41	46.00	-6.59	QP
5		533.8321	45.12	-6.40	38.72	46.00	-7.28	QP
6		742.2587	37.87	-3.13	34.74	46.00	-11.26	QP

Remark:

Correct Factor = Cable loss + Antenna factor – Preamplifier;

Level = Reading Level + Correct Factor; Margin = Limit – Level;



3.2.7 TEST RESULTS (1GHz~40GHz)

Temperature:	26°C	Relative Humidity:	54%
Pressure:	1010 hPa	Polarization :	Vertical
test voltage :	AC 120V/60Hz		
Test Mode :	Mode 1		

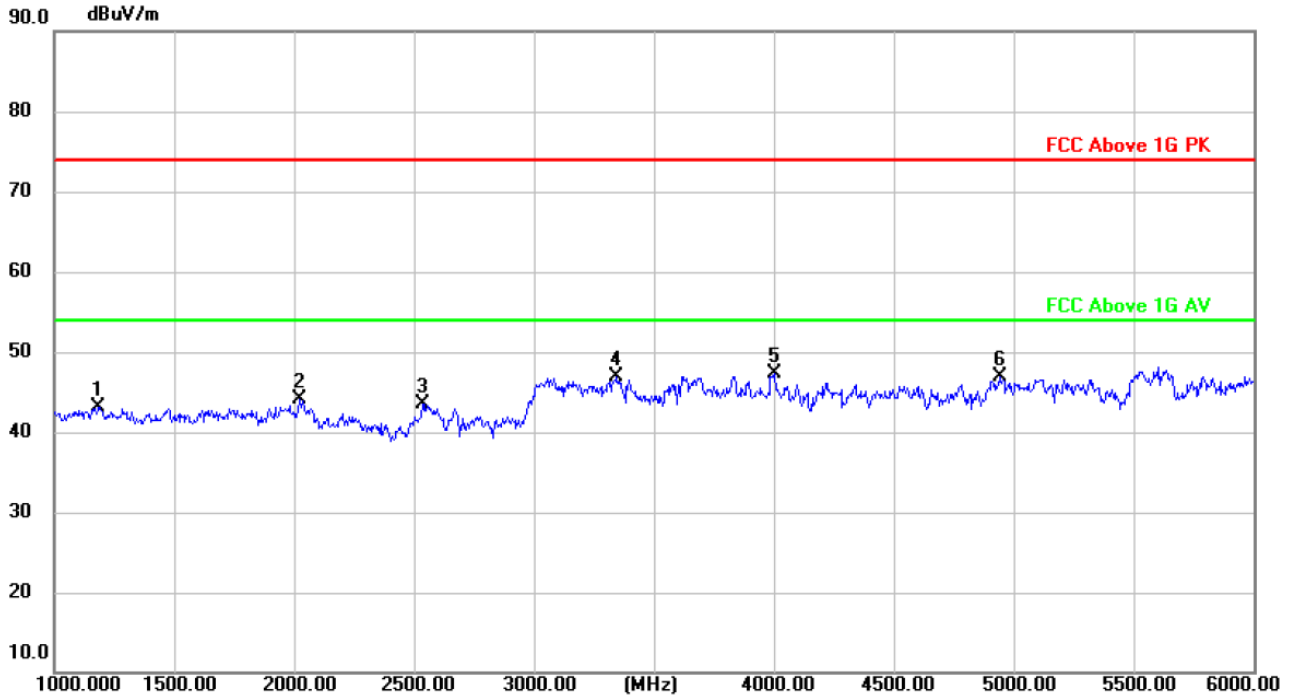

No.	Mk.	Freq. MHz	Reading Level dBuV	Correct Factor dB	Measure- ment dBuV/m	Limit dB/m	Margin dB	Detector
1		1185.000	55.20	-12.12	43.08	74.00	-30.92	peak
2		2025.000	52.44	-8.36	44.08	74.00	-29.92	peak
3		2535.000	51.27	-7.79	43.48	74.00	-30.52	peak
4		3345.000	53.29	-6.48	46.81	74.00	-27.19	peak
5	*	4000.000	54.55	-7.29	47.26	74.00	-26.74	peak
6		4940.000	52.47	-5.63	46.84	74.00	-27.16	peak

Remark:

Correct Factor = Cable loss + Antenna factor – Preamplifier;

Level = Reading Level + Correct Factor; Margin = Limit – Level;

If peak's level below the average's limit, no average's emission recording.

The emission levels of other frequencies are very lower than the limit and not show in test report.



Temperature:	26°C	Relative Humidity:	54%
Pressure:	1010 hPa	Polarization :	Horizontal
Test Voltage :	AC 120V/60Hz		
Test Mode :	Mode1		

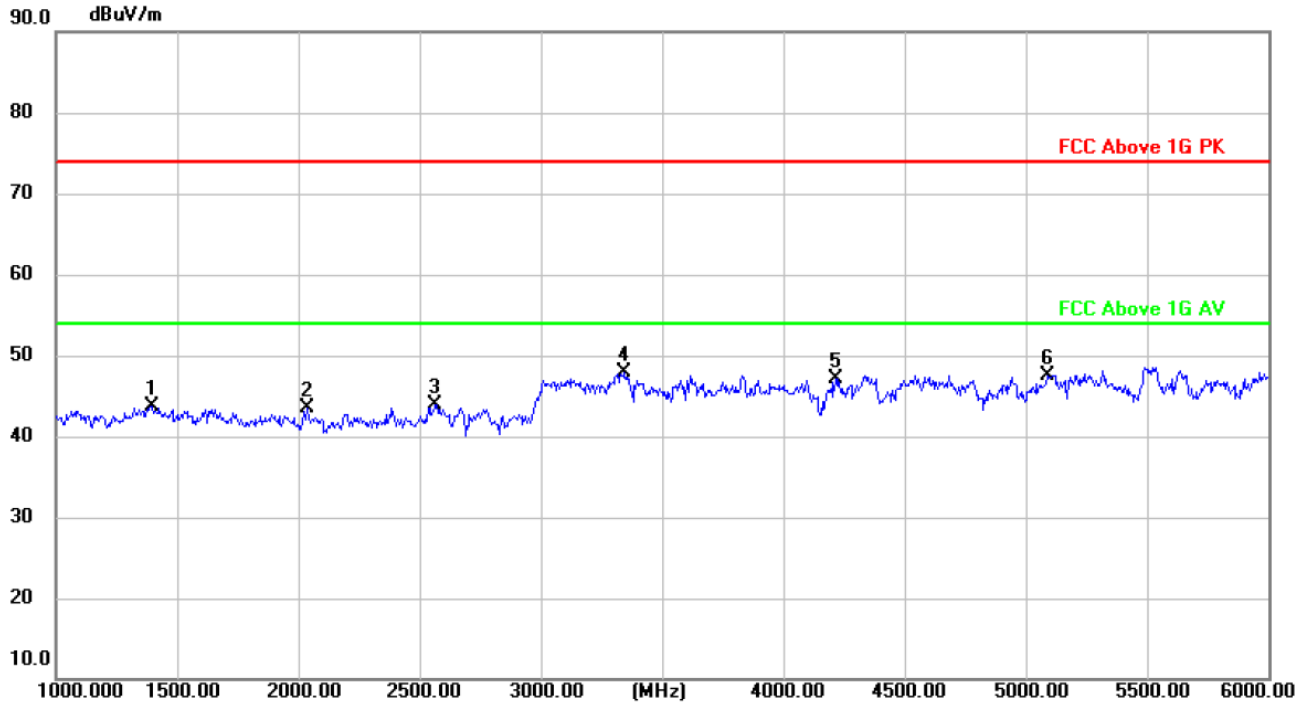

No.	Mk.	Freq. MHz	Reading Level dBuV	Correct Factor dB	Measure- ment dBuV/m	Limit dB/m	Margin dB	Detector
1		1395.000	55.10	-11.33	43.77	74.00	-30.23	peak
2		2035.000	51.86	-8.36	43.50	74.00	-30.50	peak
3		2565.000	51.63	-7.70	43.93	74.00	-30.07	peak
4	*	3345.000	54.29	-6.48	47.81	74.00	-26.19	peak
5		4215.000	53.99	-6.90	47.09	74.00	-26.91	peak
6		5090.000	52.97	-5.47	47.50	74.00	-26.50	peak

Remark:
 Correct Factor = Cable loss + Antenna factor – Preamplifier;
 Level = Reading Level + Correct Factor; Margin = Limit – Level;
 If peak’s level below the average’s limit, no average’s emission recording.
 The emission levels of other frequencies are very lower than the limit and not show in test report.



4. TEST SEUUP PHOTO

Radiated Measurement Photos

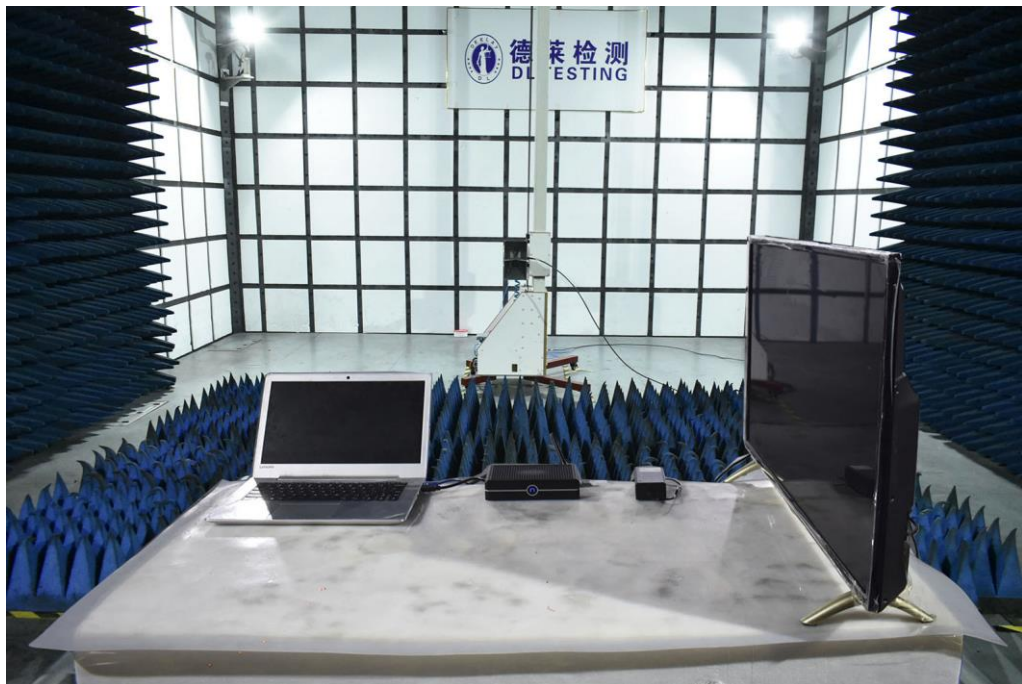
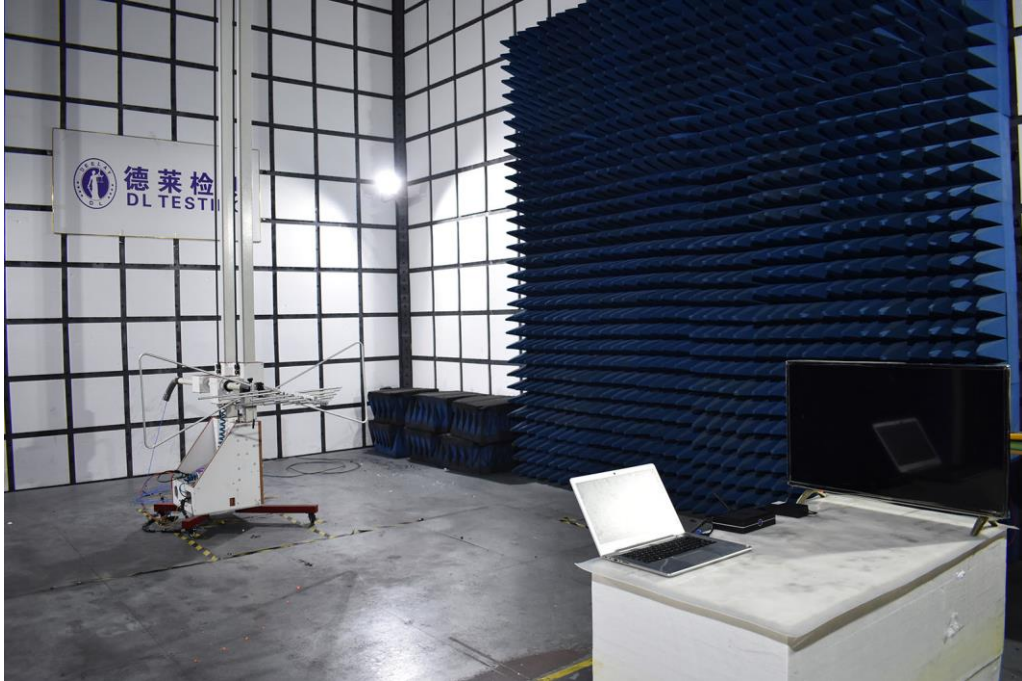



Conducted Measurement Photos



5. EUT PHOTO



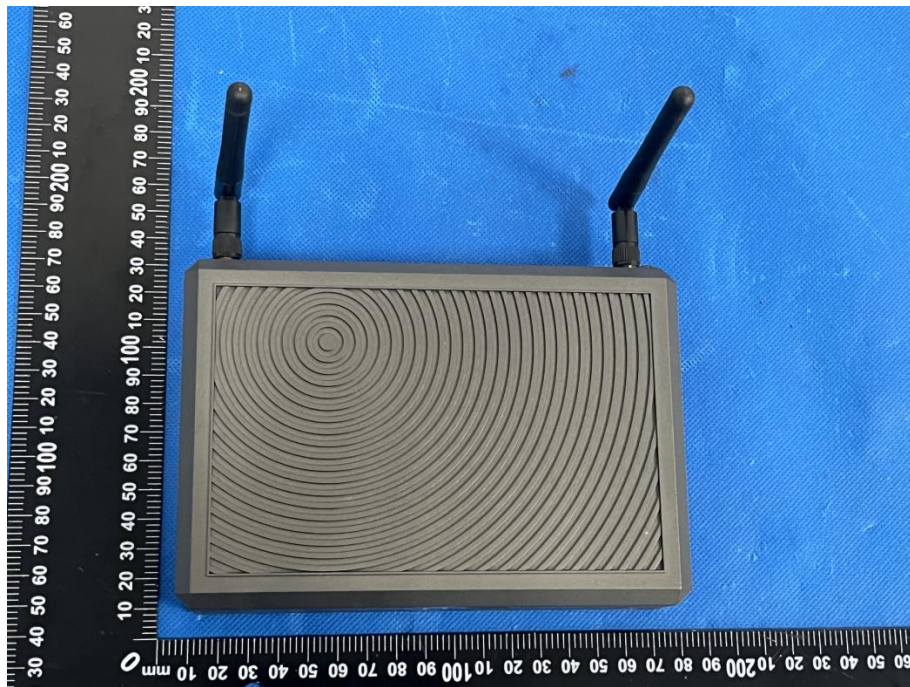

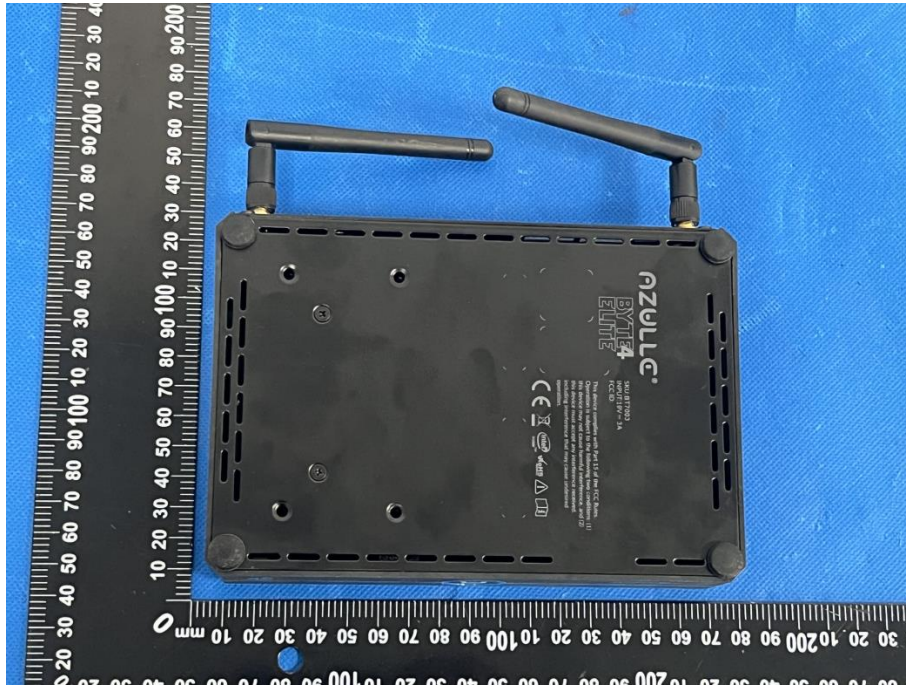

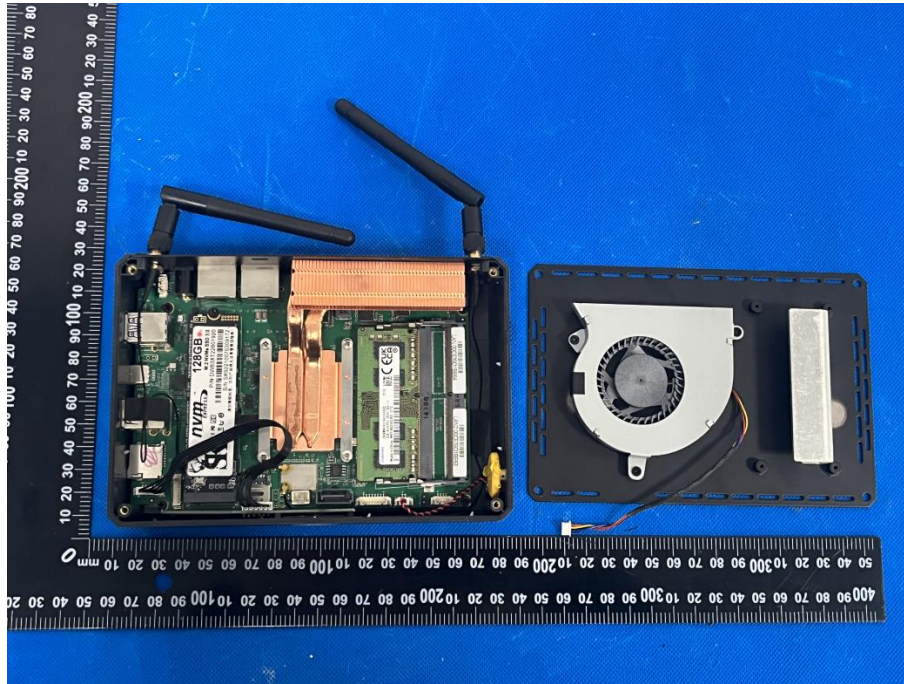

***** END OF REPORT *****