

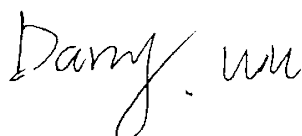



TEST REPORT

Report No.:	E20190417601701-7	Application No.:	E20190417601701
Applicant:	GL Technologies (HongKong) Limited		
Address:	Unit 210D ,2/F Enterprise Place HongKong Science Park Shatin,N.T. Hong Kong, China		
Sample Description:	Spitz 4G LTE Smart Router		
Model:	GL-X750C4		
Adding Model:	/		
FCC ID:	2AFIW-X750C4		
Test Specification:	FCC 47 CFR Part 15 Subpart E		
Test Date:	2019-04-22 to 2019-06-04		
Issue Date:	2019-06-13		
Test Result:	PASS		
Prepared By:	Reviewed By:	Approved By:	
Darry Wu / Test Engineer	Eve Wang / Technical Manager	Tony Han / Manager	
			
Date: 2019-06-13	Date: 2019-06-13	Date: 2019-06-13	
Other Aspects:	/		
Abbreviations: ok / P = passed; fail / F = failed; n.a. / N = not applicable			
The test result in this test report refers exclusively to the presented test sample. This report shall not be reproduced except in full, without the written approval of GRGT.			

DIRECTIONS OF TEST

1. This company carries out test task according to the national regulation of verifications which can be traced to National Primary Standards and BIPM.
2. The test report merely corresponds to the test sample. It is not permitted to copy extracts of these test result without the written permission of the test laboratory.
3. If there is any objection concerning the test, the client should inform the laboratory within 15 days from the date of receiving the test report.

TABLE OF CONTENTS

1. TEST RESULT SUMMARY	5
2. GENERAL DESCRIPTION OF EUT.....	6
2.1. APPLICANT	6
2.2. MANUFACTURER	6
2.3. FACTORY	6
2.4. BASIC DESCRIPTION OF EQUIPMENT UNDER TEST	6
2.5. TEST OPERATION MODE	8
2.6. LOCAL SUPPORTIVE INSTRUMENTS	8
3. LABORATORY AND ACCREDITATIONS	10
3.1. LABORATORY	10
3.2. ACCREDITATIONS	10
3.3. MEASUREMENT UNCERTAINTY	10
4. LIST OF USED TEST EQUIPMENT AT GRGT.....	11
5. ANTENNA REQUIREMENT	12
6. CONDUCTED EMISSION MEASUREMENT	13
6.1. LIMITS.....	13
6.2. TEST PROCEDURES.....	13
6.3. TEST SETUP	14
6.4. DATA SAMPLE	14
6.5. TEST RESULTS	15
7. RADIATED SPURIOUS EMISSIONS	19
7.1. LIMITS.....	19
7.2. TEST PROCEDURES.....	20
7.3. TEST SETUP	24
7.4. DATA SAMPLE	25
7.5. TEST RESULTS	26
8. EMISSION BANDWIDTH	46
8.1. LIMITS.....	46
8.2. TEST PROCEDURES.....	46
8.3. TEST SETUP	46
8.4. TEST RESULTS	47
9. OUTPUT POWER.....	59
9.1. LIMITS.....	59
9.2. TEST PROCEDURES.....	59
9.3. TEST SETUP	59
9.4. TEST RESULTS	60
10. POWER SPECTRAL DENSITY.....	63
10.1. LIMITS.....	63
10.2. TEST PROCEDURES.....	63
10.3. TEST SETUP	63
10.4. TEST RESULTS	64
11. FREQUENCY STABILITY	75
11.1. LIMITS.....	75
11.2. TEST PROCEDURES.....	75
11.3. TEST SETUP	75
11.4. TEST RESULTS	76
12. RESTRICTED BANDS OF OPERATION.....	83
12.1. LIMITS.....	83
12.2. TEST PROCEDURES.....	83
12.3. TEST SETUP	84

12.4. TEST RESULTS85

APPENDIX A: PHOTOGRAPH OF THE TEST ARRANGEMENT.....93

1. TEST RESULT SUMMARY

FCC 47 CFR Part 15 Subpart E: 15.407			
Standard	Item	Limit / Severity	Result
FCC 47 CFR Part 15 Subpart E	Emission Bandwidth	§15.407 (e) §15.403 (i)	PASS
	Conducted Emissions	§15.207 (a)	PASS
	Radiated Spurious Emission	§15.407(b) §15.209(a)	PASS
	Output Power	§15.407(a)	PASS
	Power Spectral Density	§15.407(a)	PASS
	Restricted bands of operation	§15.407(g)	PASS

2. GENERAL DESCRIPTION OF EUT

2.1. APPLICANT

Name: GL Technologies (HongKong) Limited
Address: Unit 210D ,2/F Enterprise Place HongKong Science Park Shatin,N.T.
Hong Kong, China

2.2. MANUFACTURER

Name: GL Technologies (HongKong) Limited
Address: Unit 210D ,2/F Enterprise Place HongKong Science Park Shatin,N.T.
Hong Kong, China

2.3. FACTORY

Name: Shenzhen Guanglian zhitong Tech Co.,Ltd
Address: Room 305-306, Skyworth Digital Building , Shiyan Street, Baoan District, Shenzhen, China

2.4. BASIC DESCRIPTION OF EQUIPMENT UNDER TEST

Equipment: Spitz 4G LTE Smart Router
Model No.: GL-X750C4
Adding Model: /
Model: /
Discrepancy:
Trade Name: GL.iNET
Power supply: DC12V supplied by the adapter
Adapter 1: MOSO POWER SUPPLY TECHNOLOGY CO.,LTD.
specification: Model: MSA-C1500IC12.0-18P-zz
Input: AC100-240V~50/60Hz 0.7A Max.
Output: 12V, 1.5A
DC cable: Unshielded, 1.00m
Adapter 2: Shenzhen Jiuzhou Power Technology Co.,Ltd
specification: Model: JZB024-120150X
Input: AC100-240V, 50-60Hz 0.7A
Output: 12V, 1.5A
DC cable: Unshielded, 1.40m(with a core)
Transmit Power: UNII Band I:
12.79dBm for IEEE 802.11a
12.19dBm for IEEE 802.11n HT20
13.00dBm for IEEE 802.11n HT40
7.83dBm for IEEE 802.11ac 80
UNII Band IV:
9.74dBm for IEEE 802.11a
10.57dBm for IEEE 802.11n HT20
9.62dBm for IEEE 802.11n HT40

	8.99dBm for IEEE 802.11ac 80
Modulation type:	OFDM
Antenna Specification:	Internal antenna with 5.37dBi gain (Max.)
Channels Spacing:	20MHz for IEEE 802.11a, IEEE 802.11n HT20 40MHz for IEEE 802.11n HT40 80MHz for IEEE 802.11 ac 80
Temperature Range:	-20 °C ~+40 °C
Hardware Version:	V1.0
Software Version:	V3.009
Note:	/

Frequency/Channel Information

Frequency Range(MHz)	Ch. Frequency(MHz)	Mode
5180MHz~5240MHz	5180MHz~5240MHz	802.11a; 802.11n(HT20)
	5190MHz~5230MHz	802.11n(HT40);
	5210MHz	802.11ac 80;
5745MHz~5825MHz	5745MHz~5825MHz	802.11a; 802.11n(HT20)
	5755MHz~5795MHz	802.11n(HT40);
	5775MHz	802.11ac 80;

2.5. TEST OPERATION MODE

Test Item	Mode No.	Description of the modes
Conducted Emission	1	Full system with adapter 1(AC120V/60Hz)
	2	Full system with adapter 1(AC240V/50Hz)
	3	Full system with adapter 2(AC120V/60Hz)
	4	Full system with adapter 2(AC240V/50Hz)
Radiated Emission	1	WLAN+BT+Celluar
	2	WLAN+BT
	3	WLAN+Celluar

2.6. LOCAL SUPPORTIVE INSTRUMENTS

Name of Equipment	Manufacturer	Model	Serial Number	Note
Notebook	acer	MS2392	NXMPGCN0155031 1F8C6600	/
adapter	acer	A13-45N2A	F258341423005687	/
Notebook	LENOVO	Thinkpad X270	N/A	/
SIM Card	N/A	N/A	N/A	/
TF Card	SAMSUNG	MB-MP16DA	N/A	/
HDD3.0	WD	WDBUZG0010B BL-CESN	WXC1A176SC9Z	/
Notebook (RF)	LENOVO	B475	WB04861612	/
Cable				
Power cable	/	/	/	Unshielded 1.50m
AC cable*1	/	/	/	Unshielded, 1.50m
AC cable*1				Unshielded, 1.00m
DC cable*2	/	/	/	Shielded, 1.80m
USB cable	/	/	/	Shielded, 0.50m
RJ45 cable*1	/	/	/	Unshielded, 1.50m

Test software:

Software version	Test level
Atheros Radio Test 2 (ART2-GUI)	802.11a: 17, 19 802.11n HT20: 16.5, 19 802.11n HT40: 17.5, 19 802.11ac 80: 14, 7.5

3. LABORATORY AND ACCREDITATIONS

3.1. LABORATORY

The tests and measurements refer to this report were performed by EMC Laboratory of GRG METROLOGY & TEST (SHENZHEN) CO., LTD

Add. : No. 1301, Guanguang Road, Xinlan Community, Guanlan Street, Longhua District, Shenzhen, 518110, People's Republic of China

Telephone : +86-755-61180008

Fax : /

3.2. ACCREDITATIONS

A2LA	Certificate Number 2861.01
------	----------------------------

3.3. MEASUREMENT UNCERTAINTY

Where relevant, the following measurement uncertainty levels have been estimated for tests performed on the EUT as specified in CISPR 16-4-2:

Measurement		Frequency	Uncertainty
Radiated Emission	Horizontal	30MHz~1000MHz	4.3dB
		1GHz~18GHz	5.6dB
	Vertical	30MHz~1000MHz	4.3dB
		1GHz~18GHz	5.6dB
Conducted Emission		9kHz~30MHz	2.6dB

This uncertainty represents an expanded uncertainty factor of $k=2$.

4. LIST OF USED TEST EQUIPMENT AT GRGT

Name of Equipment	Manufacturer	Model	Serial Number	Calibration Due
Conducted Emissions				
EMI TEST Receiver	ROHDE&SCHWARZ	ESCI	100783	2020-01-10
LISN(EUT)	ROHDE&SCHWARZ	ENV216	101543	2020-01-10
Hygrothermograph	VICTOR	HTC-1	N/A	2019-12-25
Test S/W	FARAD	EZ-EMC/ CCS-3A1-CE		
Radiated Spurious Emission & Restricted bands of operation				
EMI TEST Receiver	ROHDE&SCHWARZ	ESCI	100783	2020-01-10
EXA signal analyzer	Agilent	N9010A	MY52221469	2020-01-10
Wideband radio Communication Tester	ROHDE&SCHWARZ	ESCI	100783	2020-01-09
Bilog Antenna	Schwarzbeck	VULB 9160	9160-3401	2019-12-21
Horn Antenna	Schwarzbeck	BBHA9120	D286	2019-12-21
Board-Band Horn Antenna	Schwarzbeck	BBHA9170	9170-497	2020-01-15
Active Loop Antenna	COM-POWER	AL-130	121044	2019-12-27
Amplifier	EM Electronics Corporation	EM330	060661	2019-12-21
High Noise Amplifier	Agilent	8449B	3008A02060	2019-12-21
Hygrothermograph	VICTOR	HTC-1	NA	2019-12-24
Test SW	FARAD	EZ-EMC/ CCS-3A1-CE		
Emission Bandwidth				
EXA signal analyzer	Agilent	N9010A	MY52221469	2020-01-10
Output Power				
EXA signal analyzer	Agilent	N9010A	MY52221469	2020-01-10
Frequency Stability				
EXA signal analyzer	Agilent	N9010A	MY52221469	2020-01-10
Power Spectral Density				
EXA signal analyzer	Agilent	N9010A	MY52221469	2020-01-10

5. ANTENNA REQUIREMENT

The EUT has only one antenna. The antenna is internal antennas.

The max gain of antenna is 5.37dBi. which accordance 15.203.is considered sufficient to comply with the provisions of this section

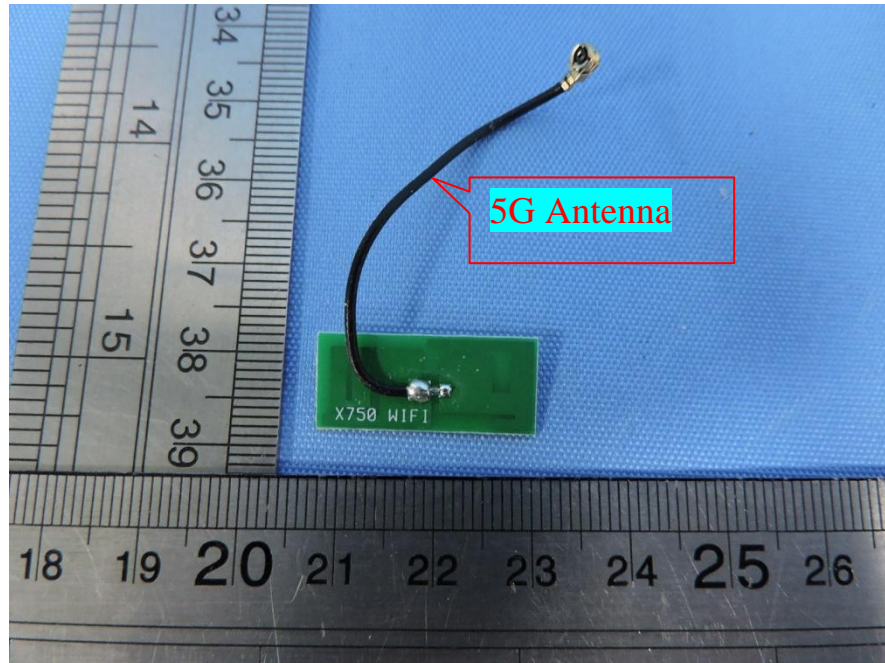

6. CONDUCTED EMISSION MEASUREMENT

6.1. LIMITS

Frequency range	Limits (dB μ V)	
	Quasi-peak	Average
150kHz ~ 0.5MHz	66~56	56~46
0.5 MHz ~ 5 MHz	56	46
5 MHz ~ 30 MHz	60	50

NOTE: (1) The lower limit shall apply at the transition frequencies.

(2) The limit decreases in line with the logarithm of the frequency in the range of 150 kHz to 0.5MHz.

6.2. TEST PROCEDURES

Procedure of Preliminary Test

Test procedures follow ANSI C63.4:2014.

For measurement of the disturbance voltage the equipment under test (EUT) is connected to the power supply mains and any other extended network via one or more artificial network(s). An EUT, whether intended to be grounded or not, and which is to be used on a table is configured as follows:

- Either the bottom or the rear of the EUT shall be at a controlled distance of 40 cm from a reference ground plane. This ground plane is normally the wall or floor of a shielded room. It may also be a grounded metal plane of at least 2 m by 2 m. This is physically accomplished as follows:
 - 1) place the EUT on a table of non-conducting material which is at least 80 cm high. Place the EUT so that it is 40 cm from the wall of the shielded room, or
 - 2) place the EUT on a table of non-conducting material which is 40 cm high so that the bottom of the EUT is 40 cm above the ground plane;
- All other conductive surfaces of the EUT shall be at least 80 cm from the reference ground plane;
- The EUT are placed on the floor that one side of the housings is 40 cm from the vertical reference ground plane and other metallic parts;
- Interconnecting cables that hang closer than 40 cm to the ground plane shall be folded back and forth forming a bundle 30 cm to 40 cm long, hanging approximately in the middle between the ground plane and the table.
- I/O cables that are connected to a peripheral shall be bundled in the centre. The end of the cable may be terminated if required using correct terminating impedance. The total length shall not exceed 1 m.

The test mode(s) described in Item 2.4 were scanned during the preliminary test. After the preliminary scan, we found the test mode described in Item 2.4 producing the highest emission level. The EUT configuration and cable configuration of the above highest emission levels were recorded for reference of the final test.

Procedure of Final Test

EUT and support equipment were set up on the test bench as per the configuration with highest emission level in the preliminary test. A scan was taken on both power lines, recording at least the six highest emissions. Emission frequency and amplitude were recorded into a computer in which correction factors were used to calculate the emission level and compare reading to the applicable limit. The test data of the worst-case condition(s) was recorded.

6.3. TEST SETUP

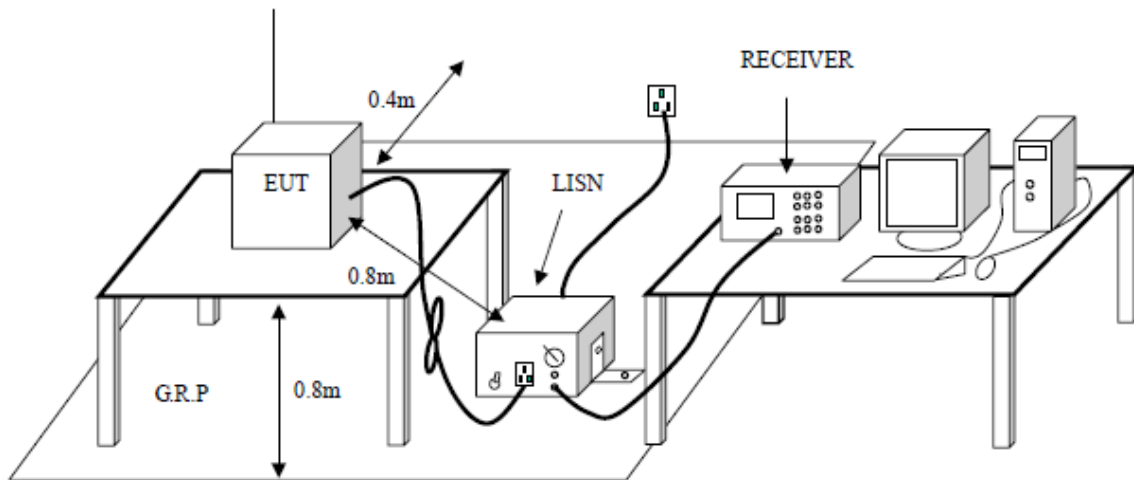

6.4. DATA SAMPLE

Frequency (MHz)	QuasiPeak Reading (dBuV)	Average Reading (dBuV)	Correction Factor (dB)	QuasiPeak Result (dBuV)	Average Result (dBuV)	QuasiPeak Limit (dBuV)	Average Limit (dBuV)	QuasiPeak Margin (dB)	Average Margin (dB)	Remark (Pass/Fail)
X.XXXX	32.69	25.65	11.52	44.21	37.17	65.78	55.79	-21.57	-18.62	Pass

- Factor = Insertion loss of LISN + Cable Loss
- Result = Quasi-peak Reading/ Average Reading + Factor
- Limit = Limit stated in standard
- Margin = Result (dBuV) – Limit (dBuV)

6.5. TEST RESULTS

Pre-test Mode 1~Mode 4, found that Mode 1, Mode 2 are the worst case.

Model No.	GL-X750C4	RBW,VBW	9 kHz
Environmental Conditions	26.1°C, 60% RH	Test Mode	Mode 1
Tested by	Luja Huang	Line	L
Tested Date	2019-04-22	Test Voltage	AC120V/60Hz

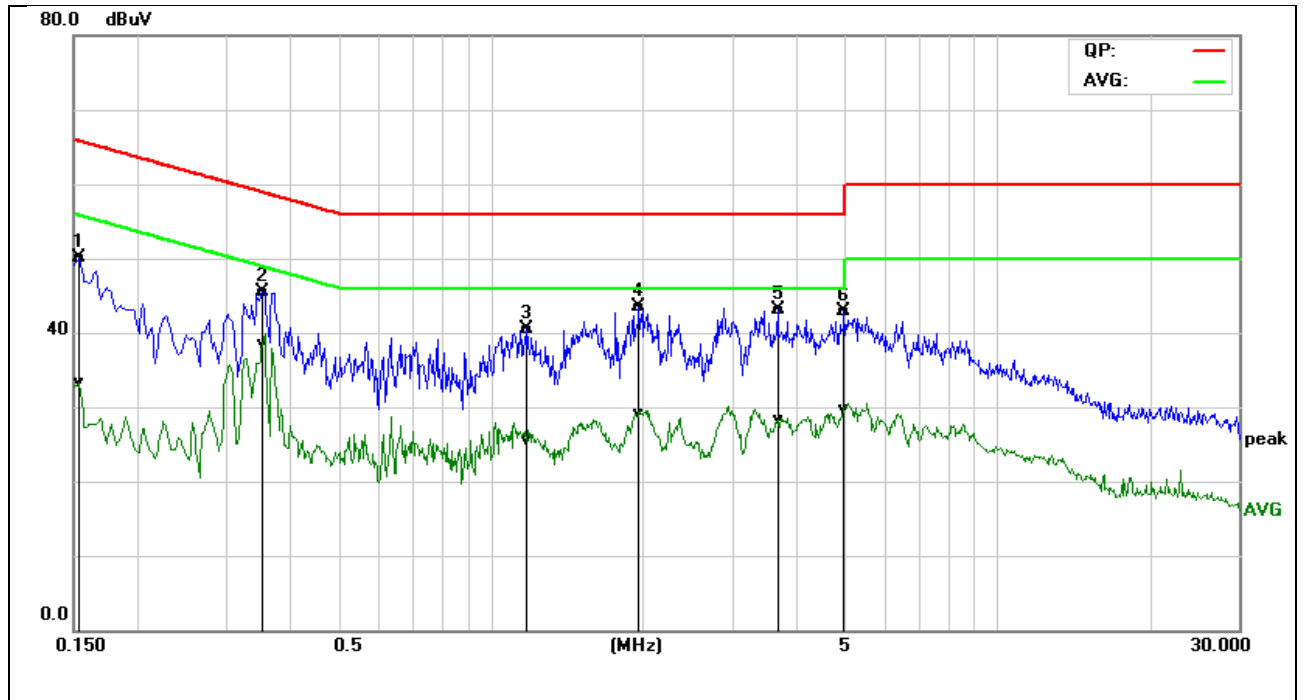

Frequency (MHz)	QuasiPeak Reading (dBuV)	Average Reading (dBuV)	Correction Factor (dB)	QuasiPeak Result (dBuV)	Average Result (dBuV)	QuasiPeak Limit (dBuV)	Average Limit (dBuV)	QuasiPeak Margin (dB)	Average Margin (dB)	Remark (Pass/Fail)
0.1539	30.16	13.47	19.88	50.04	33.35	65.78	55.79	-15.74	-22.44	Pass
0.3540	25.64	18.69	19.83	45.47	38.52	58.87	48.87	-13.40	-10.35	Pass
1.1820	20.73	5.64	19.85	40.58	25.49	56.00	46.00	-15.42	-20.51	Pass
1.9620	23.55	9.11	19.92	43.47	29.03	56.00	46.00	-12.53	-16.97	Pass
3.6980	23.18	8.30	19.93	43.11	28.23	56.00	46.00	-12.89	-17.77	Pass
4.9940	22.88	9.75	19.93	42.81	29.68	56.00	46.00	-13.19	-16.32	Pass

REMARKS: L= Live Line

Model No.	GL-X750C4	RBW,VBW	9 kHz
Environmental Conditions	26.1°C, 60% RH	Test Mode	Mode 1
Tested by	Luja Huang	Line	N
Tested Date	2019-04-22	Test Voltage	AC120V/60Hz

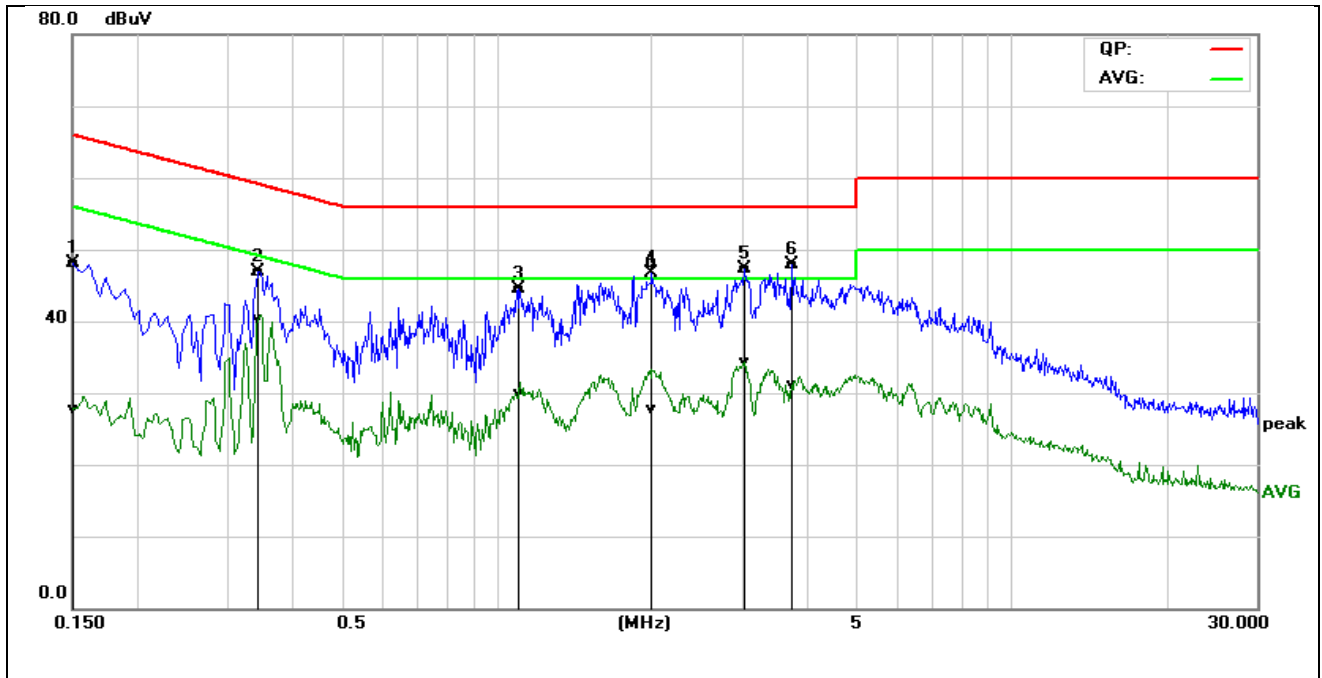

Frequency (MHz)	QuasiPeak Reading (dBuV)	Average Reading (dBuV)	Correction Factor (dB)	QuasiPeak Result (dBuV)	Average Result (dBuV)	QuasiPeak Limit (dBuV)	Average Limit (dBuV)	QuasiPeak Margin (dB)	Average Margin (dB)	Remark (Pass/Fail)
0.1500	28.25	7.91	19.87	48.12	27.78	65.99	56.00	-17.87	-28.22	Pass
0.3460	27.05	20.55	19.83	46.88	40.38	59.06	49.06	-12.18	-8.68	Pass
1.1060	24.71	10.15	19.85	44.56	30.00	56.00	46.00	-11.44	-16.00	Pass
2.0100	28.21	7.87	19.91	48.12	27.78	56.00	46.00	-7.88	-18.22	Pass
3.0260	27.32	14.45	19.91	47.23	34.36	56.00	46.00	-8.77	-11.64	Pass
3.7540	27.92	11.21	19.92	47.84	31.13	56.00	46.00	-8.16	-14.87	Pass

REMARKS: N= Neutral Line

Model No.	GL-X750C4	RBW,VBW	9 kHz
Environmental Conditions	26.1°C, 60% RH	Test Mode	Mode 2
Tested by	Luja Huang	Line	L
Tested Date	2019-04-22	Test Voltage	AC240V/50Hz

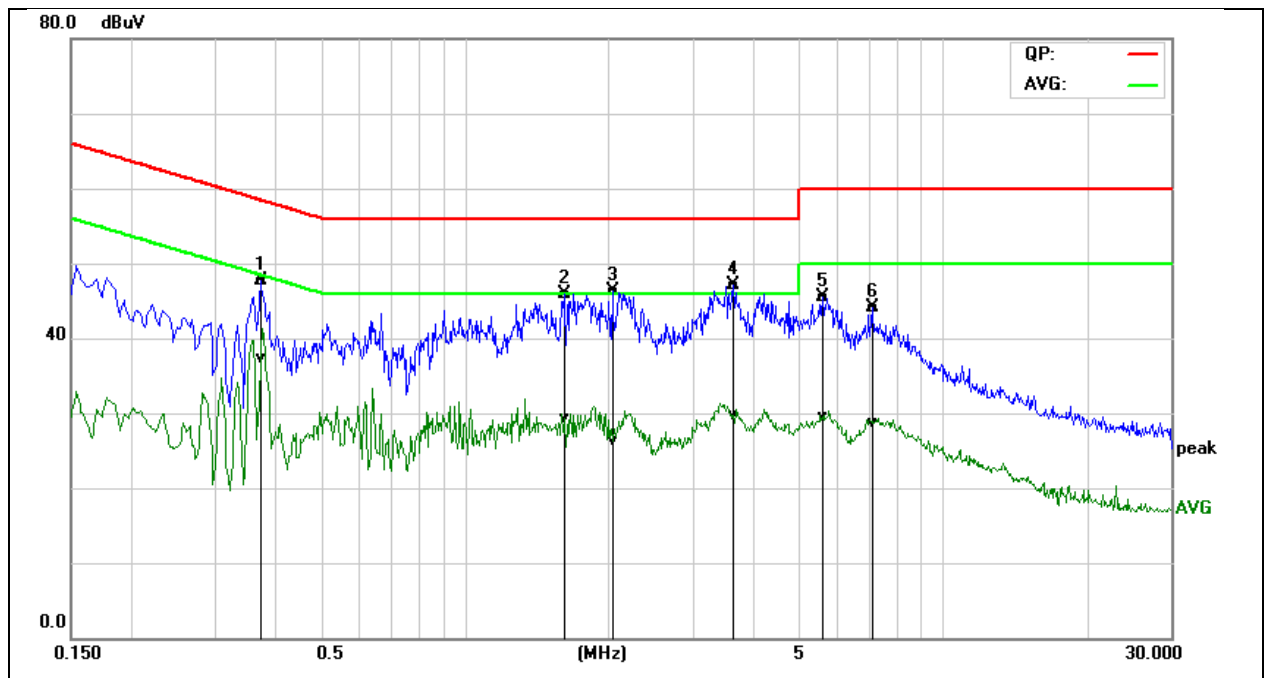

Frequency (MHz)	QuasiPeak Reading (dBuV)	Average Reading (dBuV)	Correction Factor (dB)	QuasiPeak Result (dBuV)	Average Result (dBuV)	QuasiPeak Limit (dBuV)	Average Limit (dBuV)	QuasiPeak Margin (dB)	Average Margin (dB)	Remark (Pass/Fail)
0.3740	27.80	17.50	19.83	47.63	37.33	58.41	48.41	-10.78	-11.08	Pass
1.6180	26.08	9.39	19.89	45.97	29.28	56.00	46.00	-10.03	-16.72	Pass
2.0380	26.36	6.37	19.92	46.28	26.29	56.00	46.00	-9.72	-19.71	Pass
3.6540	27.10	9.70	19.93	47.03	29.63	56.00	46.00	-8.97	-16.37	Pass
5.6100	25.65	9.57	19.93	45.58	29.50	60.00	50.00	-14.42	-20.50	Pass
7.1180	24.23	8.79	19.94	44.17	28.73	60.00	50.00	-15.83	-21.27	Pass

REMARKS: L = Live Line

Model No.	GL-X750C4	RBW,VBW	9 kHz
Environmental Conditions	26.1°C, 60% RH	Test Mode	Mode 2
Tested by	Luja Huang	Line	N
Tested Date	2019-04-22	Test Voltage	AC240V/50Hz

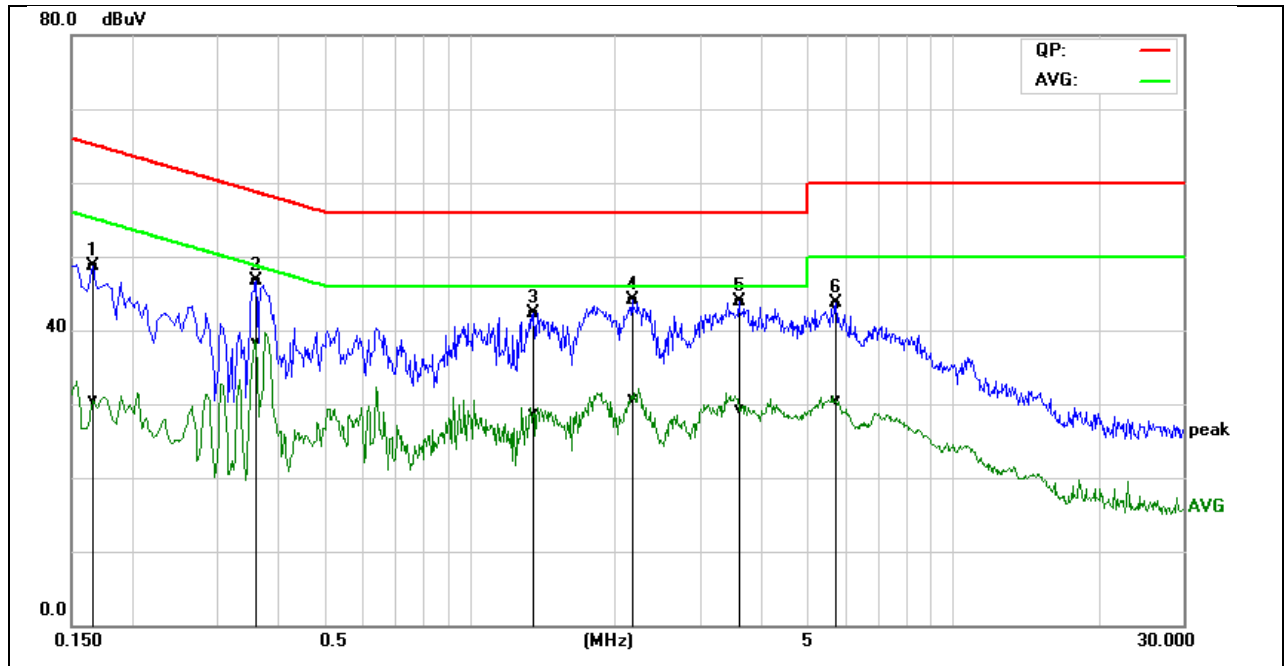

Frequency (MHz)	QuasiPeak Reading (dBuV)	Average Reading (dBuV)	Correction Factor (dB)	QuasiPeak Result (dBuV)	Average Result (dBuV)	QuasiPeak Limit (dBuV)	Average Limit (dBuV)	QuasiPeak Margin (dB)	Average Margin (dB)	Remark (Pass/Fail)
0.1660	28.76	10.57	19.86	48.62	30.43	65.15	55.16	-16.53	-24.73	Pass
0.3620	26.87	18.44	19.83	46.70	38.27	58.68	48.68	-11.98	-10.41	Pass
1.3580	22.47	8.76	19.86	42.33	28.62	56.00	46.00	-13.67	-17.38	Pass
2.1780	24.17	10.77	19.91	44.08	30.68	56.00	46.00	-11.92	-15.32	Pass
3.6220	23.98	9.44	19.92	43.90	29.36	56.00	46.00	-12.10	-16.64	Pass
5.7300	23.68	10.54	19.92	43.60	30.46	60.00	50.00	-16.40	-19.54	Pass

REMARKS: N= Neutral Line

7. RADIATED SPURIOUS EMISSIONS

7.1. LIMITS

Except as provided elsewhere in this subpart, the emissions from an intentional radiator shall not exceed the field strength levels specified in the following table:

FCC 15.209			
Frequency (MHz)	Quasi-peak($\mu\text{V}/\text{m}$)	Measurement distance(m)	Quasi-peak($\text{dB}\mu\text{V}/\text{m}$)@distance 3m
0.009-0.490	2400/F(kHz)	300	53.8~88.5
0.490-1.705	24000/F(kHz)	30	43~53.8
1.705-30.0	30	30	49.5
30 ~ 88	100	3	40
88~216	150	3	43.5
216 ~ 960	200	3	46
Above 960	500	3	54

NOTE: 1. The lower limit shall apply at the transition frequencies.

2. Emission level ($\text{dB}\mu\text{V}/\text{m}$) = 20 log Emission level ($\mu\text{V}/\text{m}$).

3. For frequencies above 1000MHz, the field strength limits are based on average detector, however, the peak field strength of any emission shall not exceed the maximum permitted average limits, specified above by more than 20dB under any condition of modulation.

1) For transmitters operating in the 5.15-5.25 GHz band: All emissions outside of the 5.15-5.35 GHz band shall not exceed an e.i.r.p. of -27 dBm/MHz.

2) For transmitters operating in the 5.25-5.35 GHz band: All emissions outside of the 5.15-5.35 GHz band shall not exceed an e.i.r.p. of -27 dBm/MHz.

3) For transmitters operating in the 5.47-5.725 GHz band: All emissions outside of the 5.47-5.725 GHz band shall not exceed an e.i.r.p. of -27 dBm/MHz.

4) For transmitters operating in the 5.725-5.85 GHz band:

All emissions shall be limited to a level of -27 dBm/MHz at 75 MHz or more above or below the band edge increasing linearly to 10 dBm/MHz at 25 MHz above or below the band edge, and from 25 MHz above or below the band edge increasing linearly to a level of 15.6 dBm/MHz at 5 MHz above or below the band edge, and from 5 MHz above or below the band edge increasing linearly to a level of 27 dBm/MHz at the band edge.

FCC 15.407			
Frequency Band (MHz)	Frequency (MHz)	EIRP Limit (dBm)	Equivalent Field Strength (3m) (dB μ V/m)
5150 - 5250	Outside of the 5.15~5.35 GHz	-27	68.2
5250 - 5350	Outside of the 5.15~5.35 GHz		
5470 - 5725	Outside of the 5.47~5.725 GHz		
5725 - 5850	< 5650	-27	68.2
	5650~5700	-27~10	68.2~105.2
	5700~5720	10~15.6	105.2~110.8
	5720~5725	15.6~27	110.8~122.2
	5850~5855	27~15.6	122.2~110.8
	5855~5875	15.6~10	110.8~105.2
	5875~5925	10~-27	105.2~68.2
	> 5925	-27	68.2

7.2. TEST PROCEDURES

1) Sequence of testing 9 kHz to 30 MHz

Setup:

- The equipment was set up to simulate a typical usage like described in the user manual or described by manufacturer.
- If the EUT is a tabletop system, a rotatable table with 0.8 m height is used.
- If the EUT is a floor standing device, it is placed on the ground.
- Auxiliary equipment and cables were positioned to simulate normal operation conditions.
- The AC power port of the EUT (if available) is connected to a power outlet below the turntable.
- The measurement distance is 3 meter.
- The EUT was set into operation.

Pre measurement:

- The turntable rotates from 0 ° to 315 ° using 45 ° steps.
- The antenna height is 0.8 meter.
- At each turntable position the analyzer sweeps with peak detection to find the maximum of all emissions

Final measurement:

- Identified emissions during the pre measurement the software maximizes by rotating the turntable position (0 ° to 360 °) and by rotating the elevation axes (0 ° to 360 °).
- The final measurement will be done in the position (turntable and elevation) causing the highest emissions with QPK detector.
- The final levels, frequency, measuring time, bandwidth, turntable position, correction factor, margin to the limit and limit will be recorded. Also a plot with the graph of the pre measurement and the limit will be stored.

2) Sequence of testing 30 MHz to 1 GHz**Setup:**

- The equipment was set up to simulate a typical usage like described in the user manual or described by manufacturer.
- If the EUT is a tabletop system, a table with 0.8 m height is used, which is placed on the ground plane.
- If the EUT is a floor standing device, it is placed on the ground plane with insulation between both.
- Auxiliary equipment and cables were positioned to simulate normal operation conditions
- The AC power port of the EUT (if available) is connected to a power outlet below the turntable.
- The measurement distance is 3 meter.
- The EUT was set into operation.

Pre measurement:

- The turntable rotates from 0 ° to 315 ° using 45 ° steps.
- The antenna is polarized vertical and horizontal.
- The antenna height changes from 1 to 3 meter.
- At each turntable position, antenna polarization and height the analyzer sweeps three times in peak to find the maximum of all emissions.

Final measurement:

- The final measurement will be performed with minimum the six highest peaks.
- According to the maximum antenna and turntable positions of premeasurement the software maximize the peaks by changing turntable position ($\pm 45^\circ$) and antenna movement between 1 and 4 meter.
- The final measurement will be done with QP detector with an EMI receiver.
- The final levels, frequency, measuring time, bandwidth, antenna height, antenna polarization, turntable angle, correction factor, margin to the limit and limit will be recorded. Also a plot with the graph of the premeasurement with marked maximum final measurements and the limit will be stored.

3) Sequence of testing 1 GHz to 18 GHz**Setup:**

- The equipment was set up to simulate a typical usage like described in the user manual or described by manufacturer.
- If the EUT is a tabletop system, a rotatable table with 1.5 m height is used.
- If the EUT is a floor standing device, it is placed on the ground plane with insulation between both.
- Auxiliary equipment and cables were positioned to simulate normal operation conditions
- The AC power port of the EUT (if available) is connected to a power outlet below the turntable.
- The measurement distance is 3 meter.
- The EUT was set into operation.

Pre measurement:

- The turntable rotates from 0° to 315° using 45° steps.
- The antenna is polarized vertical and horizontal.
- The antenna height scan range is 1 meter to 2.5 meter.
- At each turntable position and antenna polarization the analyzer sweeps with peak detection to find the maximum of all emissions.

Final measurement:

- The final measurement will be performed with minimum the six highest peaks.
- According to the maximum antenna and turntable positions of premeasurement the software maximize the peaks by changing turntable position ($\pm 45^\circ$) and antenna movement between 1 and 4 meter. This procedure is repeated for both antenna polarizations.
- The final measurement will be done in the position (turntable, EUT-table and antenna polarization) causing the highest emissions with Peak and Average detector.
- The final levels, frequency, measuring time, bandwidth, turntable position, EUT-table position, antenna polarization, correction factor, margin to the limit and limit will be recorded. Also a plot with the graph of the pre measurement with marked maximum final measurements and the limit will be stored.

4) Sequence of testing above 18 GHz**Setup:**

- The equipment was set up to simulate a typical usage like described in the user manual or described by manufacturer.
- If the EUT is a tabletop system, a rotatable table with 1.5 m height is used.
- If the EUT is a floor standing device, it is placed on the ground plane with insulation between both.
- Auxiliary equipment and cables were positioned to simulate normal operation conditions
- The AC power port of the EUT (if available) is connected to a power outlet below the turntable.
- The measurement distance is 1 meter.
- The EUT was set into operation.

Pre measurement:

- The antenna is moved spherical over the EUT in different polarisations of the antenna.

Final measurement:

- The final measurement will be performed at the position and antenna orientation for all detected emissions that were found during the premeasurements with Peak and Average detector.
- The final levels, frequency, measuring time, bandwidth, correction factor, margin to the limit and limit will be recorded. Also a plot with the graph of the premeasurement and the limit will be stored.

NOTE: The resolution bandwidth of test receiver/spectrum analyzer is 1MHz and the video bandwidth is 3MHz for RMS Average (Duty cycle < 98%) for Average detection (AV) at frequency above 1GHz, then the measurement results was added to a correction factor ($10 \log(1/\text{duty cycle})$).

7.3. TEST SETUP

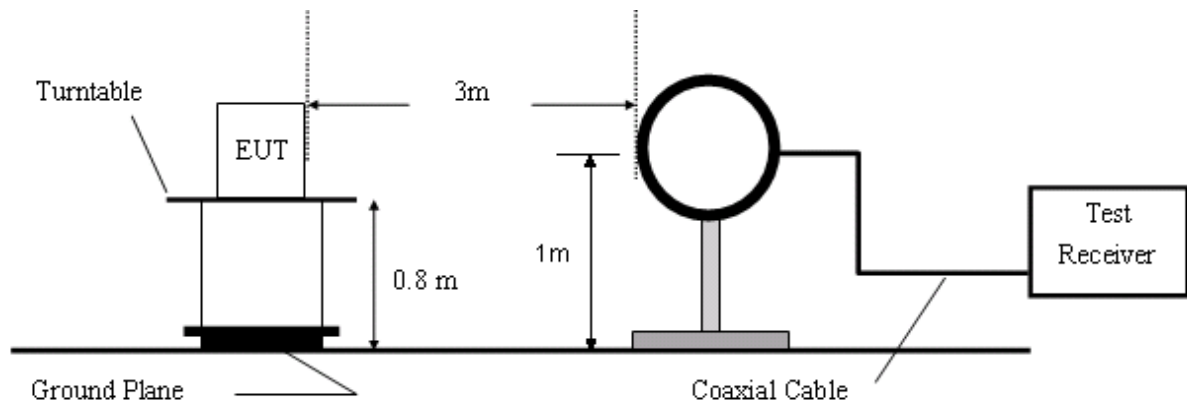

Figure 1. 9KHz to 30MHz radiated emissions test configuration

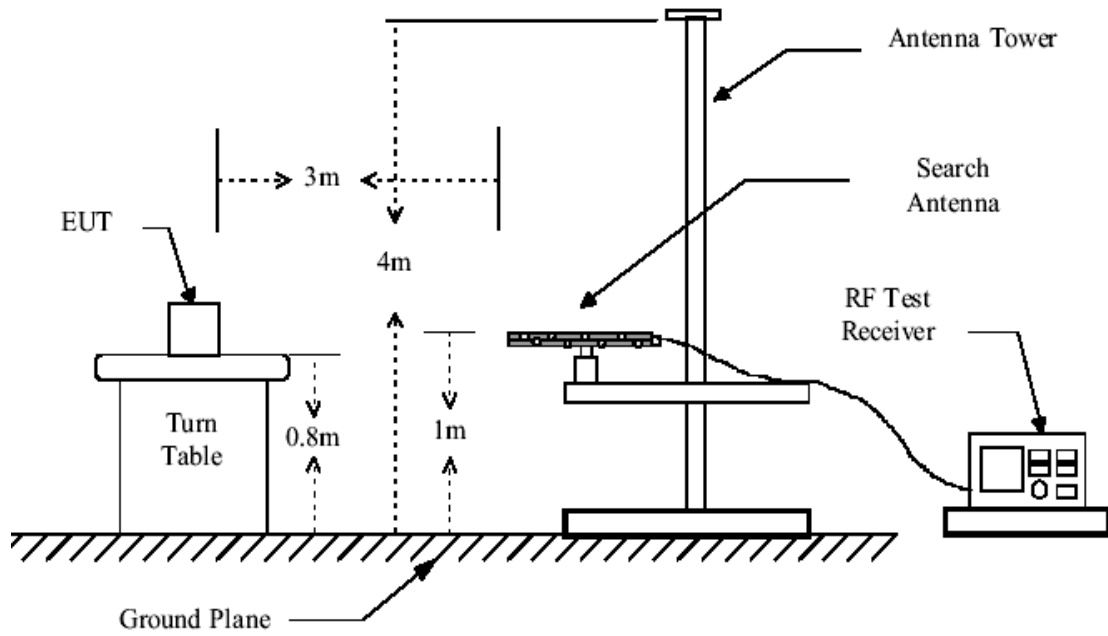

Figure 2. 30MHz to 1GHz radiated emissions test configuration

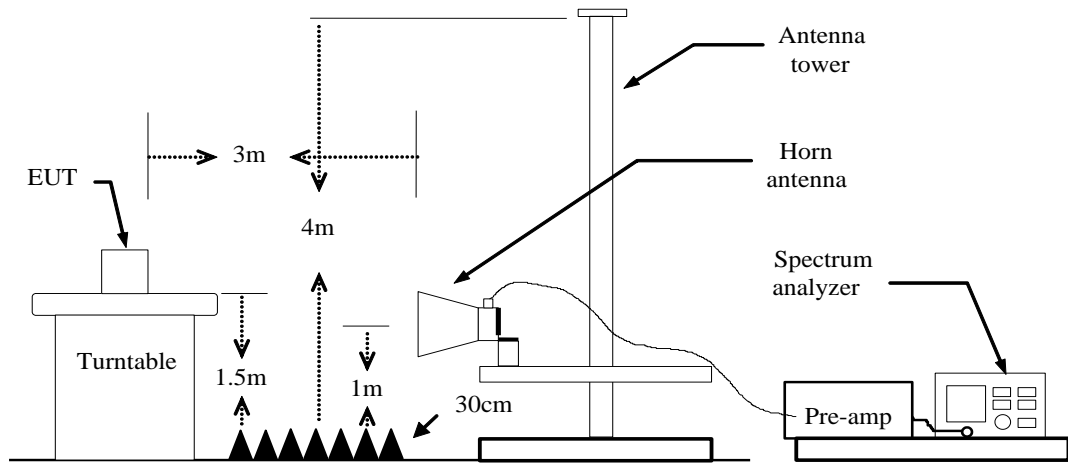

Figure 3. Above 1GHz radiated emissions test configuration

7.4. DATA SAMPLE

30MHz to 1GHz

No.	Frequency	Reading	Correct	Result	Limit	Margin	Remark	Pole
	(MHz)	(dBuV/m)	Factor(dB/m)	(dBuV/m)	(dBuV/m)	(dB)		
xxx	xxx	37.06	-15.48	21.58	40.00	-18.42	QP	Vertical

Above 1 GHz

No.	Frequency	Reading	Correct	Result	Limit	Margin	Remark	Pole
	(MHz)	(dBuV/m)	Factor(dB/m)	(dBuV/m)	(dBuV/m)	(dB)		
xxx	xxx	65.45	-11.12	54.33	74.00	-19.67	peak	Vertical
xxx	xxx	63.00	-11.12	51.88	54.00	-2.12	AVG	Vertical

- Frequency (MHz) = Emission frequency in MHz
- Ant.Pol. (H/V) = Antenna polarization
- Reading (dBuV) = Uncorrected Analyzer / Receiver reading
- Correction Factor (dB/m) = Antenna factor + Cable loss – Amplifier gain
- Result (dBuV/m) = Reading (dBuV) + Correction Factor (dB/m)
- Limit (dBuV/m) = Limit stated in standard
- Margin (dB) = Remark Result (dBuV/m) – Limit (dBuV/m)
- Peak = Peak Reading
- QP = Quasi-peak Reading
- AVG = Average Reading

7.5. TEST RESULTS

30MHz to 1GHz

Pre-scan all modes and recorded the worst case mode 1 results in this report (IEEE 802.11a (Low Channel))

Mode: TX/ IEEE 802.11a

Lowest channel (5180MHz)

Date: 2019-05-26

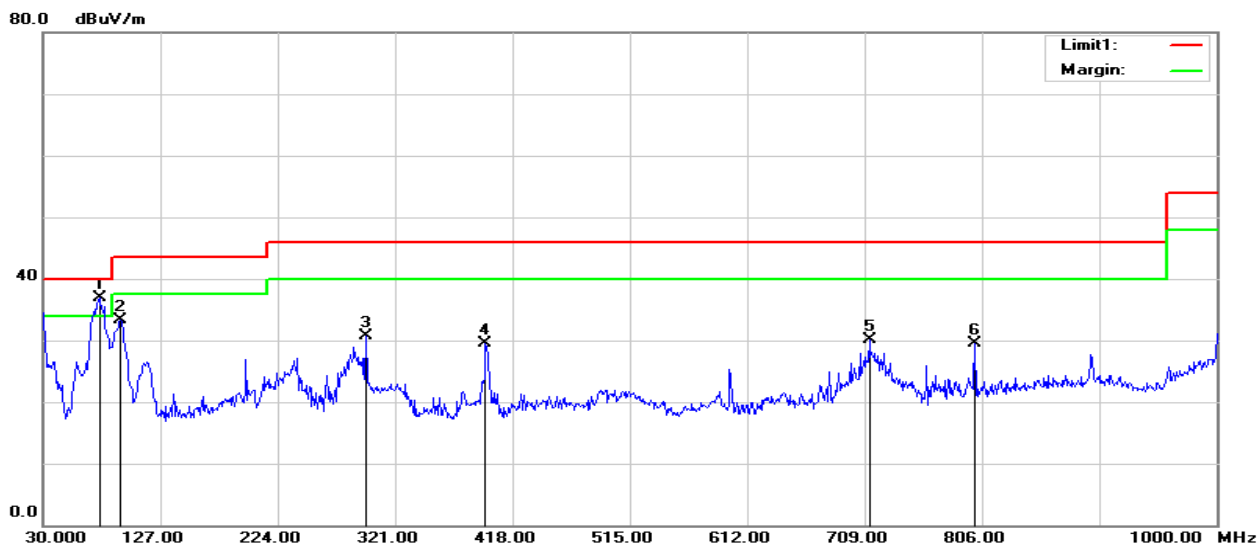

No.	Frequency (MHz)	Reading (dBuV/m)	Correct Factor(dB/m)	Result (dBuV/m)	Limit (dBuV/m)	Margin (dB)	Remark	Pole
1	76.5600	57.10	-20.22	36.88	40.00	-3.12	QP	Vertical
2	94.0200	52.41	-19.19	33.22	43.50	-10.28	QP	Vertical
3	296.7500	46.76	-16.03	30.73	46.00	-15.27	QP	Vertical
4	395.6900	43.02	-13.42	29.60	46.00	-16.40	QP	Vertical
5	712.8800	36.64	-6.50	30.14	46.00	-15.86	QP	Vertical
6	800.1800	36.51	-7.08	29.43	46.00	-16.57	QP	Vertical

Mode: TX/ IEEE 802.11a
 Lowest channel (5180MHz)

Date: 2019-05-26

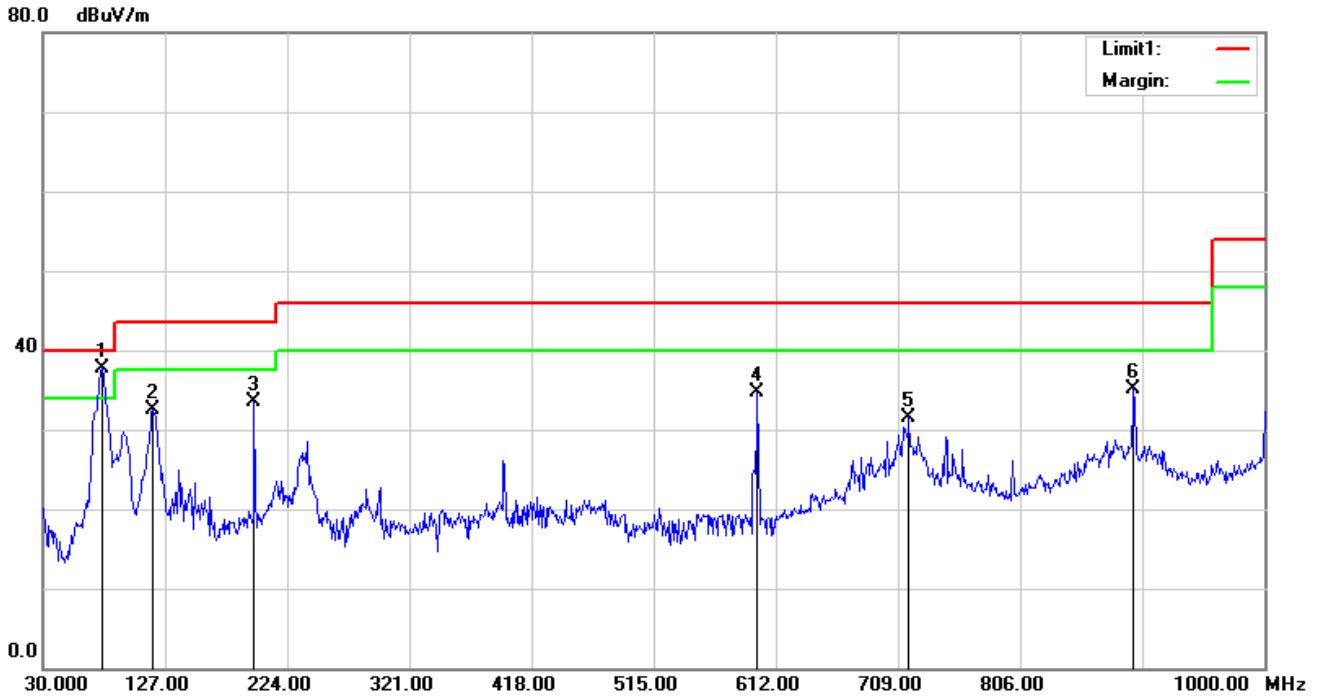

No.	Frequency	Reading	Correct	Result	Limit	Margin	Remark	Pole
	(MHz)	(dBuV/m)	Factor(dB/m)	(dBuV/m)	(dBuV/m)	(dB)		
1	76.5600	58.02	-20.22	37.80	40.00	-2.20	QP	Horizontal
2	117.3000	50.02	-17.43	32.59	43.50	-10.91	QP	Horizontal
3	197.8100	51.45	-18.00	33.45	43.50	-10.05	QP	Horizontal
4	597.4500	43.15	-8.52	34.63	46.00	-11.37	QP	Horizontal
5	717.7300	38.05	-6.56	31.49	46.00	-14.51	QP	Horizontal
6	896.2100	39.38	-4.26	35.12	46.00	-10.88	QP	Horizontal

Above 1 GHz (1GHz~6GHz)

Pre-scan all modes and recorded the worst case mode 1 results in this report (IEEE 802.11a (Low Channel))

Mode: TX / IEEE 802.11a

Lowest channel (5180MHz)

Date: 2019-05-23

No.	Frequency (MHz)	Reading (dBuV/m)	Correct Factor(dB/m)	Result (dBuV/m)	Limit (dBuV/m)	Margin (dB)	Remark	Pole
1	1920.000	56.32	-2.82	53.50	74.00	-20.50	peak	Vertical
2	1920.000	47.65	-2.82	44.83	54.00	-9.17	AVG	Vertical
3	2130.000	53.58	-2.06	51.52	74.00	-22.48	peak	Vertical
4	2500.000	47.61	-1.24	46.37	74.00	-27.63	peak	Vertical
5	3080.000	45.51	0.91	46.42	74.00	-27.58	peak	Vertical
6	3455.000	45.68	0.92	46.60	74.00	-27.40	peak	Vertical
7	5760.000	44.85	4.50	49.35	74.00	-24.65	peak	Vertical
8	1020.000	51.71	-6.61	45.10	74.00	-28.90	peak	Horizontal
9	1330.000	50.55	-5.79	44.76	74.00	-29.24	peak	Horizontal
10	1920.000	59.29	-2.82	56.47	74.00	-17.53	peak	Horizontal
11	1920.000	54.85	-2.82	52.03	54.00	-1.97	AVG	Horizontal
12	2130.000	51.46	-2.06	49.40	74.00	-24.60	peak	Horizontal
13	2500.000	47.26	-1.24	46.02	74.00	-27.98	peak	Horizontal
14	4670.000	42.96	2.44	45.40	74.00	-28.60	peak	Horizontal

Above 6GHz

Pre-scan all modes and recorded the worst case mode 1 results in this report

Mode: TX / IEEE 802.11a

Lowest channel (5180MHz)

Date: 2019-05-26

No.	Frequency	Reading	Correct	Result	Limit	Margin	Remark	Pole
	(MHz)	(dBuV/m)	Factor(dB/m)	(dBuV/m)	(dBuV/m)	(dB)		
1	7296.000	32.34	7.78	40.12	74.00	-33.88	peak	Vertical
2	8352.000	33.14	8.99	42.13	74.00	-31.87	peak	Vertical
3	9360.000	31.84	10.01	41.85	74.00	-32.15	peak	Vertical
4	10356.000	39.30	11.94	51.24	74.00	-22.76	peak	Vertical
5	11136.000	31.95	13.56	45.51	74.00	-28.49	peak	Vertical
6	12276.000	31.38	13.23	44.61	74.00	-29.39	peak	Vertical
7	7224.000	32.24	7.60	39.84	74.00	-34.16	peak	Horizontal
8	8160.000	32.68	9.10	41.78	74.00	-32.22	peak	Horizontal
9	10356.000	41.12	11.94	53.06	74.00	-20.94	peak	Horizontal
10	10356.000	39.69	11.94	51.63	54.00	-2.37	AVG	Horizontal
11	11148.000	31.97	13.58	45.55	74.00	-28.45	peak	Horizontal
12	11940.000	31.21	13.13	44.34	74.00	-29.66	peak	Horizontal
13	15540.000	35.87	13.87	49.74	74.00	-24.26	peak	Horizontal

Mode: TX / IEEE 802.11a

middle channel (5200MHz)

Date: 2019-05-26

No.	Frequency	Reading	Correct	Result	Limit	Margin	Remark	Pole
	(MHz)	(dBuV/m)	Factor(dB/m)	(dBuV/m)	(dBuV/m)	(dB)		
1	7512.000	31.95	8.30	40.25	74.00	-33.75	peak	Vertical
2	8112.000	32.35	9.13	41.48	74.00	-32.52	peak	Vertical
3	9384.000	32.47	10.06	42.53	74.00	-31.47	peak	Vertical
4	10404.000	42.30	12.07	54.37	74.00	-19.63	peak	Vertical
5	10404.000	39.72	12.07	51.79	54.00	-2.21	AVG	Vertical
6	11148.000	31.62	13.58	45.20	74.00	-28.80	peak	Vertical
7	12528.000	30.87	13.44	44.31	74.00	-29.69	peak	Vertical
8	7356.000	32.28	7.92	40.20	74.00	-33.80	peak	Horizontal
9	8016.000	32.55	9.18	41.73	74.00	-32.27	peak	Horizontal
10	9312.000	32.67	9.92	42.59	74.00	-31.41	peak	Horizontal
11	10404.000	36.27	12.07	48.34	74.00	-25.66	peak	Horizontal
12	11328.000	31.76	13.76	45.52	74.00	-28.48	peak	Horizontal
13	13236.000	29.89	15.17	45.06	74.00	-28.94	peak	Horizontal

Mode: TX / IEEE 802.11a

Highest channel (5240MHz)

Date: 2019-05-25

No.	Frequency	Reading	Correct	Result	Limit	Margin	Remark	Pole
	(MHz)	(dBuV/m)	Factor(dB/m)	(dBuV/m)	(dBuV/m)	(dB)		
1	7524.000	32.64	8.32	40.96	74.00	-33.04	peak	Vertical
2	8436.000	33.39	8.94	42.33	74.00	-31.67	peak	Vertical
3	9432.000	32.02	10.15	42.17	74.00	-31.83	peak	Vertical
4	10476.000	39.11	12.24	51.35	74.00	-22.65	peak	Vertical
5	11136.000	32.00	13.56	45.56	74.00	-28.44	peak	Vertical
6	12624.000	31.03	13.60	44.63	74.00	-29.37	peak	Vertical
7	7620.000	32.46	8.49	40.95	74.00	-33.05	peak	Horizontal
8	9552.000	31.70	10.36	42.06	74.00	-31.94	peak	Horizontal
9	10476.000	43.07	12.24	55.31	74.00	-18.69	peak	Horizontal
10	10476.000	39.31	12.24	51.55	54.00	-2.45	AVG	Horizontal
11	11172.000	32.08	13.60	45.68	74.00	-28.32	peak	Horizontal
12	12240.000	31.24	13.20	44.44	74.00	-29.56	peak	Horizontal
13	15720.000	35.90	13.62	49.52	74.00	-24.48	peak	Horizontal

Mode: TX / IEEE 802.11a

Lowest channel (5745MHz)

Date: 2019-06-04

No.	Frequency	Reading	Correct	Result	Limit	Margin	Remark	Pole
	(MHz)	(dBuV/m)	Factor(dB/m)	(dBuV/m)	(dBuV/m)	(dB)		
1	7164.000	31.62	7.46	39.08	74.00	-34.92	peak	Vertical
2	7884.000	32.21	8.98	41.19	74.00	-32.81	peak	Vertical
3	9912.000	32.04	10.92	42.96	74.00	-31.04	peak	Vertical
4	10284.000	31.45	11.76	43.21	74.00	-30.79	peak	Vertical
5	11484.000	35.34	13.90	49.24	74.00	-24.76	peak	Vertical
6	12540.000	31.17	13.46	44.63	74.00	-29.37	peak	Vertical
7	7164.000	31.90	7.46	39.36	74.00	-34.64	peak	Horizontal
8	7944.000	32.40	9.09	41.49	74.00	-32.51	peak	Horizontal
9	10380.000	31.65	12.00	43.65	74.00	-30.35	peak	Horizontal
10	11136.000	31.30	13.56	44.86	74.00	-29.14	peak	Horizontal
11	11820.000	31.39	13.35	44.74	74.00	-29.26	peak	Horizontal
12	12588.000	30.92	13.54	44.46	74.00	-29.54	peak	Horizontal

Mode: TX / IEEE 802.11a
middle channel (5785MHz)

Date: 2019-06-04

No.	Frequency	Reading	Correct	Result	Limit	Margin	Remark	Pole
	(MHz)	(dBuV/m)	Factor(dB/m)	(dBuV/m)	(dBuV/m)	(dB)		
1	7704.000	31.90	8.65	40.55	74.00	-33.45	peak	Vertical
2	8580.000	32.35	8.96	41.31	74.00	-32.69	peak	Vertical
3	9012.000	32.47	9.34	41.81	74.00	-32.19	peak	Vertical
4	11160.000	31.78	13.60	45.38	74.00	-28.62	peak	Vertical
5	11568.000	35.36	13.80	49.16	74.00	-24.84	peak	Vertical
6	12672.000	30.62	13.69	44.31	74.00	-29.69	peak	Vertical
7	8028.000	32.02	9.17	41.19	74.00	-32.81	peak	Horizontal
8	9588.000	31.95	10.43	42.38	74.00	-31.62	peak	Horizontal
9	10284.000	32.01	11.76	43.77	74.00	-30.23	peak	Horizontal
10	11148.000	31.64	13.58	45.22	74.00	-28.78	peak	Horizontal
11	11580.000	36.37	13.78	50.15	74.00	-23.85	peak	Horizontal
12	11916.000	31.91	13.16	45.07	74.00	-28.93	peak	Horizontal

Mode: TX / IEEE 802.11a
Highest channel (5825MHz)

Date: 2019-06-04

No.	Frequency	Reading	Correct	Result	Limit	Margin	Remark	Pole
	(MHz)	(dBuV/m)	Factor(dB/m)	(dBuV/m)	(dBuV/m)	(dB)		
1	7032.000	31.79	7.14	38.93	74.00	-35.07	peak	Vertical
2	7764.000	31.84	8.75	40.59	74.00	-33.41	peak	Vertical
3	10236.000	31.42	11.64	43.06	74.00	-30.94	peak	Vertical
4	11160.000	31.66	13.60	45.26	74.00	-28.74	peak	Vertical
5	11652.000	36.76	13.66	50.42	74.00	-23.58	peak	Vertical
6	12252.000	31.60	13.21	44.81	74.00	-29.19	peak	Vertical
7	8124.000	32.26	9.13	41.39	74.00	-32.61	peak	Horizontal
8	10128.000	31.99	11.38	43.37	74.00	-30.63	peak	Horizontal
9	10932.000	31.67	13.27	44.94	74.00	-29.06	peak	Horizontal
10	11652.000	31.59	13.66	45.25	74.00	-28.75	peak	Horizontal
11	12084.000	31.73	13.09	44.82	74.00	-29.18	peak	Horizontal
12	12804.000	30.87	13.92	44.79	74.00	-29.21	peak	Horizontal

Mode: TX / IEEE 802.11n HT20

Lowest channel (5180MHz)

Date: 2019-05-26

No.	Frequency	Reading	Correct	Result	Limit	Margin	Remark	Pole
	(MHz)	(dBuV/m)	Factor(dB/m)	(dBuV/m)	(dBuV/m)	(dB)		
1	8064.000	32.14	9.15	41.29	74.00	-32.71	peak	Vertical
2	8400.000	32.87	8.96	41.83	74.00	-32.17	peak	Vertical
3	10356.000	41.96	11.94	53.90	74.00	-20.10	peak	Vertical
4	10356.000	39.92	11.94	51.86	54.00	-2.14	AVG	Vertical
5	11172.000	31.56	13.60	45.16	74.00	-28.84	peak	Vertical
6	11508.000	31.21	13.91	45.12	74.00	-28.88	peak	Vertical
7	15540.000	35.39	13.87	49.26	74.00	-24.74	peak	Vertical
8	8400.000	32.60	8.96	41.56	74.00	-32.44	peak	Horizontal
9	8964.000	32.31	9.28	41.59	74.00	-32.41	peak	Horizontal
10	10356.000	39.37	11.94	51.31	74.00	-22.69	peak	Horizontal
11	11148.000	31.69	13.58	45.27	74.00	-28.73	peak	Horizontal
12	11472.000	31.09	13.90	44.99	74.00	-29.01	peak	Horizontal
13	15540.000	34.92	13.87	48.79	74.00	-25.21	peak	Horizontal

Mode: TX / IEEE 802.11n HT20

middle channel (5200MHz)

Date: 2019-05-26

No.	Frequency	Reading	Correct	Result	Limit	Margin	Remark	Pole
	(MHz)	(dBuV/m)	Factor(dB/m)	(dBuV/m)	(dBuV/m)	(dB)		
1	7668.000	32.01	8.58	40.59	74.00	-33.41	peak	Vertical
2	8064.000	32.65	9.15	41.80	74.00	-32.20	peak	Vertical
3	10404.000	41.79	12.07	53.86	74.00	-20.14	peak	Vertical
4	10404.000	39.55	12.07	51.62	54.00	-2.38	AVG	Vertical
5	11160.000	31.92	13.60	45.52	74.00	-28.48	peak	Vertical
6	12060.000	32.02	13.07	45.09	74.00	-28.91	peak	Vertical
7	14316.000	31.25	17.41	48.66	74.00	-25.34	peak	Vertical
8	7320.000	32.22	7.83	40.05	74.00	-33.95	peak	Horizontal
9	8400.000	32.60	8.96	41.56	74.00	-32.44	peak	Horizontal
10	9336.000	31.94	9.97	41.91	74.00	-32.09	peak	Horizontal
11	10404.000	34.72	12.07	46.79	74.00	-27.21	peak	Horizontal
12	11244.000	31.93	13.67	45.60	74.00	-28.40	peak	Horizontal
13	13164.000	29.73	14.89	44.62	74.00	-29.38	peak	Horizontal

Mode: TX / IEEE 802.11n HT20

Highest channel (5240MHz)

Date: 2019-05-26

No.	Frequency	Reading	Correct	Result	Limit	Margin	Remark	Pole
	(MHz)	(dBuV/m)	Factor(dB/m)	(dBuV/m)	(dBuV/m)	(dB)		
1	6828.000	32.85	6.70	39.55	74.00	-34.45	peak	Vertical
2	8100.000	32.87	9.13	42.00	74.00	-32.00	peak	Vertical
3	10476.000	42.21	12.24	54.45	74.00	-19.55	peak	Vertical
4	10476.000	39.55	12.24	51.79	54.00	-2.21	AVG	Vertical
5	11160.000	31.46	13.60	45.06	74.00	-28.94	peak	Vertical
6	11556.000	31.43	13.82	45.25	74.00	-28.75	peak	Vertical
7	12132.000	31.09	13.12	44.21	74.00	-29.79	peak	Vertical
8	7284.000	32.55	7.74	40.29	74.00	-33.71	peak	Horizontal
9	8424.000	33.09	8.95	42.04	74.00	-31.96	peak	Horizontal
10	9396.000	31.95	10.08	42.03	74.00	-31.97	peak	Horizontal
11	10488.000	35.85	12.27	48.12	74.00	-25.88	peak	Horizontal
12	11148.000	31.81	13.58	45.39	74.00	-28.61	peak	Horizontal
13	12180.000	31.27	13.16	44.43	74.00	-29.57	peak	Horizontal

Mode: TX / IEEE 802.11n HT20

Lowest channel (5745MHz)

Date: 2019-06-04

No.	Frequency	Reading	Correct	Result	Limit	Margin	Remark	Pole
	(MHz)	(dBuV/m)	Factor(dB/m)	(dBuV/m)	(dBuV/m)	(dB)		
1	7068.000	31.99	7.23	39.22	74.00	-34.78	peak	Vertical
2	8364.000	32.68	8.98	41.66	74.00	-32.34	peak	Vertical
3	10596.000	31.17	12.50	43.67	74.00	-30.33	peak	Vertical
4	11148.000	31.53	13.58	45.11	74.00	-28.89	peak	Vertical
5	11484.000	35.69	13.90	49.59	74.00	-24.41	peak	Vertical
6	12588.000	30.82	13.54	44.36	74.00	-29.64	peak	Vertical
7	7668.000	32.30	8.58	40.88	74.00	-33.12	peak	Horizontal
8	7992.000	32.36	9.18	41.54	74.00	-32.46	peak	Horizontal
9	10224.000	30.98	11.62	42.60	74.00	-31.40	peak	Horizontal
10	11148.000	31.76	13.58	45.34	74.00	-28.66	peak	Horizontal
11	11496.000	31.38	13.92	45.30	74.00	-28.70	peak	Horizontal
12	11916.000	31.44	13.16	44.60	74.00	-29.40	peak	Horizontal

Mode: TX / IEEE 802.11n HT20
middle channel (5785MHz)

Date: 2019-06-04

No.	Frequency	Reading	Correct	Result	Limit	Margin	Remark	Pole
	(MHz)	(dBuV/m)	Factor(dB/m)	(dBuV/m)	(dBuV/m)	(dB)		
1	7200.000	31.80	7.55	39.35	74.00	-34.65	peak	Vertical
2	8172.000	32.11	9.09	41.20	74.00	-32.80	peak	Vertical
3	8988.000	31.80	9.30	41.10	74.00	-32.90	peak	Vertical
4	10752.000	30.46	12.87	43.33	74.00	-30.67	peak	Vertical
5	11136.000	31.50	13.56	45.06	74.00	-28.94	peak	Vertical
6	11568.000	33.65	13.80	47.45	74.00	-26.55	peak	Vertical
7	6816.000	32.32	6.68	39.00	74.00	-35.00	peak	Horizontal
8	7704.000	32.06	8.65	40.71	74.00	-33.29	peak	Horizontal
9	8412.000	32.67	8.95	41.62	74.00	-32.38	peak	Horizontal
10	10728.000	31.02	12.81	43.83	74.00	-30.17	peak	Horizontal
11	11568.000	31.96	13.80	45.76	74.00	-28.24	peak	Horizontal
12	11916.000	31.44	13.16	44.60	74.00	-29.40	peak	Horizontal

Mode: TX / IEEE 802.11n HT20
Highest channel (5825MHz)

Date: 2019-06-04

No.	Frequency	Reading	Correct	Result	Limit	Margin	Remark	Pole
	(MHz)	(dBuV/m)	Factor(dB/m)	(dBuV/m)	(dBuV/m)	(dB)		
1	7008.000	31.77	7.08	38.85	74.00	-35.15	peak	Vertical
2	7656.000	31.75	8.56	40.31	74.00	-33.69	peak	Vertical
3	8040.000	32.21	9.17	41.38	74.00	-32.62	peak	Vertical
4	8424.000	32.66	8.95	41.61	74.00	-32.39	peak	Vertical
5	11136.000	31.72	13.56	45.28	74.00	-28.72	peak	Vertical
6	11652.000	36.33	13.66	49.99	74.00	-24.01	peak	Vertical
7	6132.000	32.60	5.46	38.06	74.00	-35.94	peak	Horizontal
8	7452.000	31.70	8.15	39.85	74.00	-34.15	peak	Horizontal
9	8124.000	32.14	9.13	41.27	74.00	-32.73	peak	Horizontal
10	10452.000	30.91	12.17	43.08	74.00	-30.92	peak	Horizontal
11	10764.000	31.33	12.90	44.23	74.00	-29.77	peak	Horizontal
12	11652.000	33.15	13.66	46.81	74.00	-27.19	peak	Horizontal

Mode: TX / IEEE 802.11n HT40

Lowest channel (5190MHz)

Date: 2019-05-26

No.	Frequency	Reading	Correct	Result	Limit	Margin	Remark	Pole
	(MHz)	(dBuV/m)	Factor(dB/m)	(dBuV/m)	(dBuV/m)	(dB)		
1	7944.000	32.21	9.09	41.30	74.00	-32.70	peak	Vertical
2	8388.000	32.94	8.97	41.91	74.00	-32.09	peak	Vertical
3	9072.000	32.18	9.46	41.64	74.00	-32.36	peak	Vertical
4	10380.000	41.54	12.00	53.54	74.00	-20.46	peak	Vertical
5	10380.000	39.41	12.00	51.41	54.00	-2.59	AVG	Vertical
6	11148.000	31.82	13.58	45.40	74.00	-28.60	peak	Vertical
7	13236.000	29.64	15.17	44.81	74.00	-29.19	peak	Vertical
8	7536.000	31.86	8.34	40.20	74.00	-33.80	peak	Horizontal
9	8328.000	33.38	9.00	42.38	74.00	-31.62	peak	Horizontal
10	10392.000	33.97	12.03	46.00	74.00	-28.00	peak	Horizontal
11	11352.000	31.59	13.78	45.37	74.00	-28.63	peak	Horizontal
12	11940.000	31.87	13.13	45.00	74.00	-29.00	peak	Horizontal
13	12576.000	30.84	13.53	44.37	74.00	-29.63	peak	Horizontal

Mode: TX / IEEE 802.11n HT40

Highest channel (5230MHz)

Date: 2019-05-26

No.	Frequency	Reading	Correct	Result	Limit	Margin	Remark	Pole
	(MHz)	(dBuV/m)	Factor(dB/m)	(dBuV/m)	(dBuV/m)	(dB)		
1	7164.000	32.48	7.46	39.94	74.00	-34.06	peak	Vertical
2	7944.000	32.26	9.09	41.35	74.00	-32.65	peak	Vertical
3	9360.000	32.17	10.01	42.18	74.00	-31.82	peak	Vertical
4	10476.000	41.37	12.24	53.61	74.00	-20.39	peak	Vertical
5	10476.000	39.62	12.24	51.86	54.00	-2.14	AVG	Vertical
6	11316.000	31.85	13.74	45.59	74.00	-28.41	peak	Vertical
7	12660.000	30.60	13.68	44.28	74.00	-29.72	peak	Vertical
8	7008.000	32.66	7.08	39.74	74.00	-34.26	peak	Horizontal
9	8100.000	32.65	9.13	41.78	74.00	-32.22	peak	Horizontal
10	9336.000	31.83	9.97	41.80	74.00	-32.20	peak	Horizontal
11	10476.000	34.45	12.24	46.69	74.00	-27.31	peak	Horizontal
12	11148.000	32.19	13.58	45.77	74.00	-28.23	peak	Horizontal
13	12552.000	31.21	13.48	44.69	74.00	-29.31	peak	Horizontal

Mode: TX / IEEE 802.11n HT40

Lowest channel (5755MHz)

Date: 2019-06-04

No.	Frequency	Reading	Correct	Result	Limit	Margin	Remark	Pole
	(MHz)	(dBuV/m)	Factor(dB/m)	(dBuV/m)	(dBuV/m)	(dB)		
1	7320.000	31.50	7.83	39.33	74.00	-34.67	peak	Vertical
2	8160.000	32.07	9.10	41.17	74.00	-32.83	peak	Vertical
3	9756.000	31.12	10.69	41.81	74.00	-32.19	peak	Vertical
4	11148.000	31.48	13.58	45.06	74.00	-28.94	peak	Vertical
5	11508.000	36.02	13.91	49.93	74.00	-24.07	peak	Vertical
6	12612.000	30.38	13.59	43.97	74.00	-30.03	peak	Vertical
7	7944.000	32.63	9.09	41.72	74.00	-32.28	peak	Horizontal
8	9036.000	32.03	9.38	41.41	74.00	-32.59	peak	Horizontal
9	10584.000	31.40	12.49	43.89	74.00	-30.11	peak	Horizontal
10	11136.000	31.70	13.56	45.26	74.00	-28.74	peak	Horizontal
11	11508.000	32.28	13.91	46.19	74.00	-27.81	peak	Horizontal
12	12612.000	30.23	13.59	43.82	74.00	-30.18	peak	Horizontal

Mode: TX / IEEE 802.11n HT40

Highest channel (5795MHz)

Date: 2019-06-04

No.	Frequency	Reading	Correct	Result	Limit	Margin	Remark	Pole
	(MHz)	(dBuV/m)	Factor(dB/m)	(dBuV/m)	(dBuV/m)	(dB)		
1	7620.000	31.74	8.49	40.23	74.00	-33.77	peak	Vertical
2	7944.000	32.23	9.09	41.32	74.00	-32.68	peak	Vertical
3	10140.000	31.39	11.40	42.79	74.00	-31.21	peak	Vertical
4	10548.000	31.14	12.41	43.55	74.00	-30.45	peak	Vertical
5	11268.000	32.00	13.69	45.69	74.00	-28.31	peak	Vertical
6	11580.000	33.39	13.78	47.17	74.00	-26.83	peak	Vertical
7	7236.000	31.83	7.64	39.47	74.00	-34.53	peak	Horizontal
8	8124.000	32.58	9.13	41.71	74.00	-32.29	peak	Horizontal
9	8964.000	32.43	9.28	41.71	74.00	-32.29	peak	Horizontal
10	10764.000	30.48	12.90	43.38	74.00	-30.62	peak	Horizontal
11	11580.000	30.82	13.78	44.60	74.00	-29.40	peak	Horizontal
12	12588.000	30.80	13.54	44.34	74.00	-29.66	peak	Horizontal

Mode: TX / IEEE 802.11ac 80

Lowest channel (5210MHz)

Date: 2019-05-26

No.	Frequency	Reading	Correct	Result	Limit	Margin	Remark	Pole
	(MHz)	(dBuV/m)	Factor(dB/m)	(dBuV/m)	(dBuV/m)	(dB)		
1	7284.000	32.47	7.74	40.21	74.00	-33.79	peak	Vertical
2	7956.000	32.84	9.11	41.95	74.00	-32.05	peak	Vertical
3	8352.000	33.00	8.99	41.99	74.00	-32.01	peak	Vertical
4	10440.000	40.76	12.14	52.90	74.00	-21.10	peak	Vertical
5	10440.000	39.32	12.14	51.46	54.00	-2.54	AVG	Vertical
6	11172.000	32.15	13.60	45.75	74.00	-28.25	peak	Vertical
7	11484.000	31.37	13.90	45.27	74.00	-28.73	peak	Vertical
8	7104.000	32.80	7.32	40.12	74.00	-33.88	peak	Horizontal
9	8316.000	32.93	9.01	41.94	74.00	-32.06	peak	Horizontal
10	9336.000	31.78	9.97	41.75	74.00	-32.25	peak	Horizontal
11	10452.000	37.36	12.17	49.53	74.00	-24.47	peak	Horizontal
12	11160.000	31.99	13.60	45.59	74.00	-28.41	peak	Horizontal
13	11508.000	30.98	13.91	44.89	74.00	-29.11	peak	Horizontal

Mode: TX / IEEE 802.11ac 80

Lowest channel (5775MHz)

Date: 2019-06-04

No.	Frequency	Reading	Correct	Result	Limit	Margin	Remark	Pole
	(MHz)	(dBuV/m)	Factor(dB/m)	(dBuV/m)	(dBuV/m)	(dB)		
1	6804.000	32.97	6.65	39.62	74.00	-34.38	peak	Vertical
2	7932.000	32.26	9.06	41.32	74.00	-32.68	peak	Vertical
3	9012.000	32.05	9.34	41.39	74.00	-32.61	peak	Vertical
4	10704.000	30.42	12.76	43.18	74.00	-30.82	peak	Vertical
5	11496.000	31.74	13.92	45.66	74.00	-28.34	peak	Vertical
6	12588.000	33.49	13.54	47.03	74.00	-26.97	peak	Vertical
7	8064.000	32.20	9.15	41.35	74.00	-32.65	peak	Horizontal
8	8388.000	33.03	8.97	42.00	74.00	-32.00	peak	Horizontal
9	10032.000	30.79	11.14	41.93	74.00	-32.07	peak	Horizontal
10	11172.000	32.43	13.60	46.03	74.00	-27.97	peak	Horizontal
11	11508.000	33.52	13.91	47.43	74.00	-26.57	peak	Horizontal
12	12636.000	30.16	13.63	43.79	74.00	-30.21	peak	Horizontal

Remark:

1. Measuring frequencies from 1 GHz to the 10th harmonic of highest fundamental frequency.
2. Radiated emissions measured in frequency above 1000MHz were made with an instrument using peak/average detector mode.
3. Average test would be performed if the peak result were greater than the average limit.
4. Data of measurement within this frequency range shown “ --- ” in the table above means the reading of emissions are attenuated more than 20dB below the permissible limits or the field strength is too small to be measured.
5. Measurements above show only up to 6 maximum emissions noted, or would be lesser, with “ N/A ” remark, if no specific emissions from the EUT are recorded (ie: margin>20dB from the applicable limit) and considered that's already beyond the background noise floor.

Conducted undesirable emission

IEEE 802.11a mode / 5745MHz

Detector mode: Peak

Polarity: Vertical

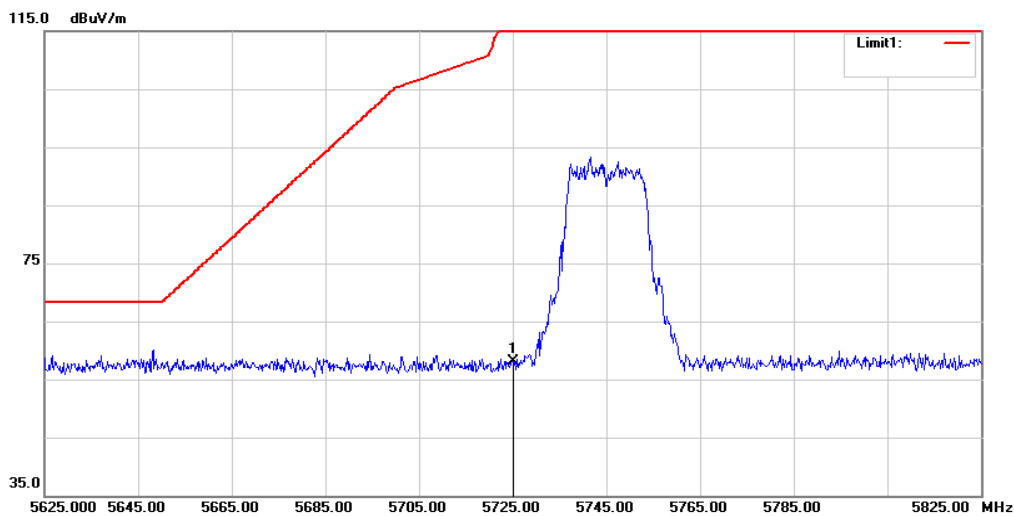

Detector mode: Peak

Polarity: Horizontal

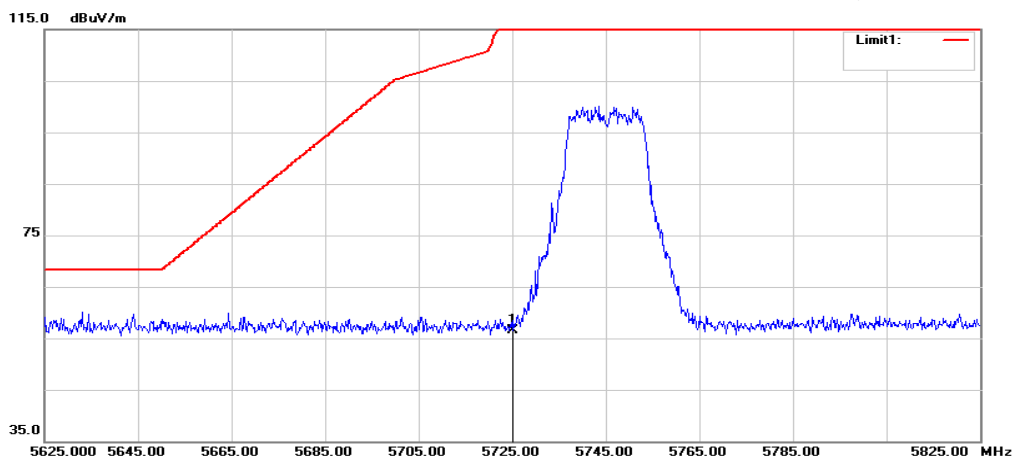

No.	Frequency (MHz)	Reading (dBuV)	Factor (dB/m)	Result (dBuV/m)	Limit (dBuV/m)	Margin (dB)	Remark	Antenna Polar
1	5725.000	53.69	4.38	58.07	122.20	-64.13	Peak	Vertical
1	5725.000	52.13	4.38	56.51	122.20	-65.69	Peak	Horizontal

IEEE 802.11a mode / 5825MHz

Detector mode: Peak

Polarity: Vertical

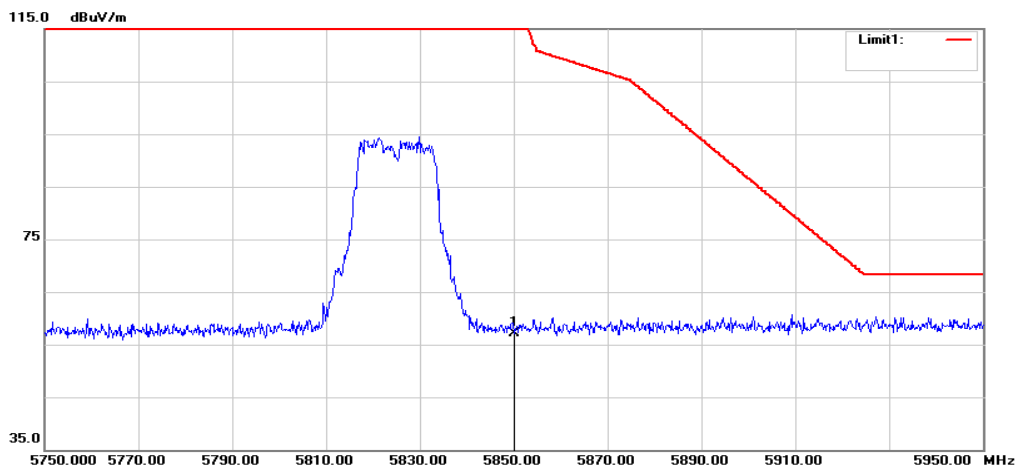

Detector mode: Peak

Polarity: Horizontal

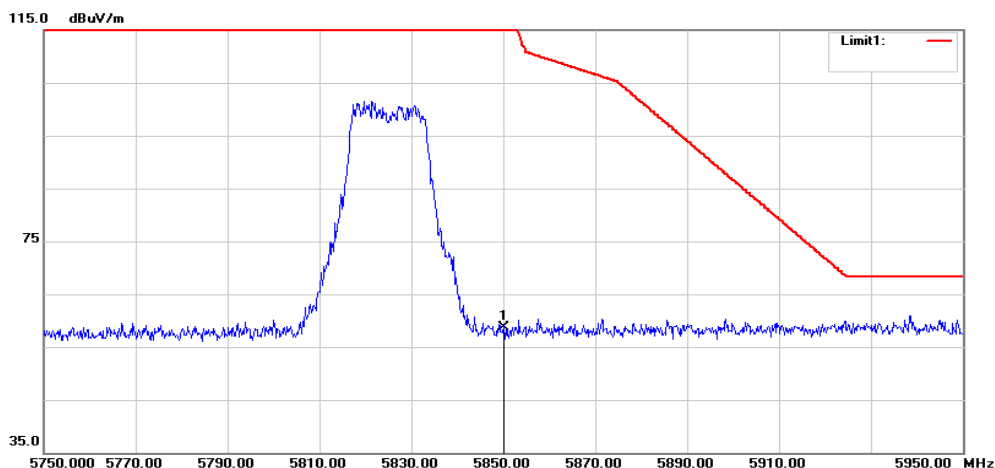

No.	Frequency (MHz)	Reading (dBuV)	Factor (dB/m)	Result (dBuV/m)	Limit (dBuV/m)	Margin (dB)	Remark	Antenna Polar
1	5850.000	52.26	4.78	57.04	122.20	-65.16	Peak	Vertical
1	5850.000	54.02	4.78	58.80	122.20	-63.40	Peak	Horizontal

IEEE 802.11n HT 20 MHz mode / 5745MHz

Detector mode: Peak

Polarity: Vertical

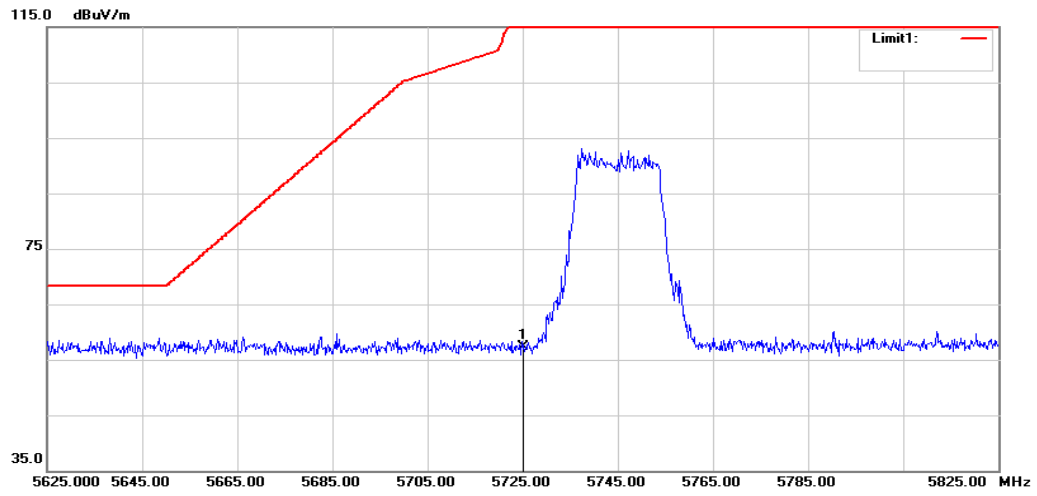

Detector mode: Peak

Polarity: Horizontal

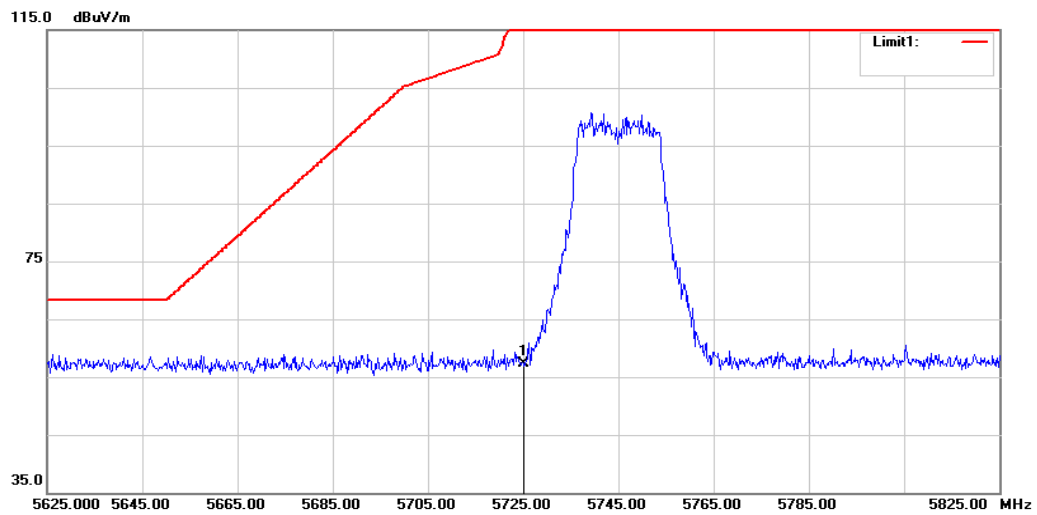

No.	Frequency (MHz)	Reading (dBuV)	Factor (dB/m)	Result (dBuV/m)	Limit (dBuV/m)	Margin (dB)	Remark	Antenna Polar
1	5725.000	53.02	4.38	57.40	122.20	-64.80	Peak	Vertical
1	5725.000	53.00	4.38	57.38	122.20	-64.82	Peak	Horizontal

IEEE 802.11n HT 20 MHz mode/ 5825MHz

Highest channel (5825MHz)

Detector mode: Peak

Polarity: Vertical

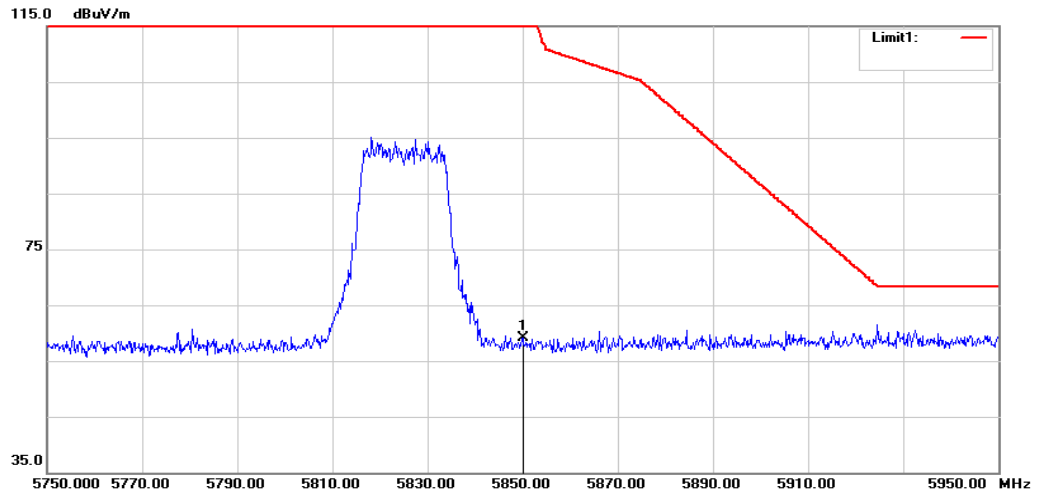

Detector mode: Peak

Polarity: Horizontal

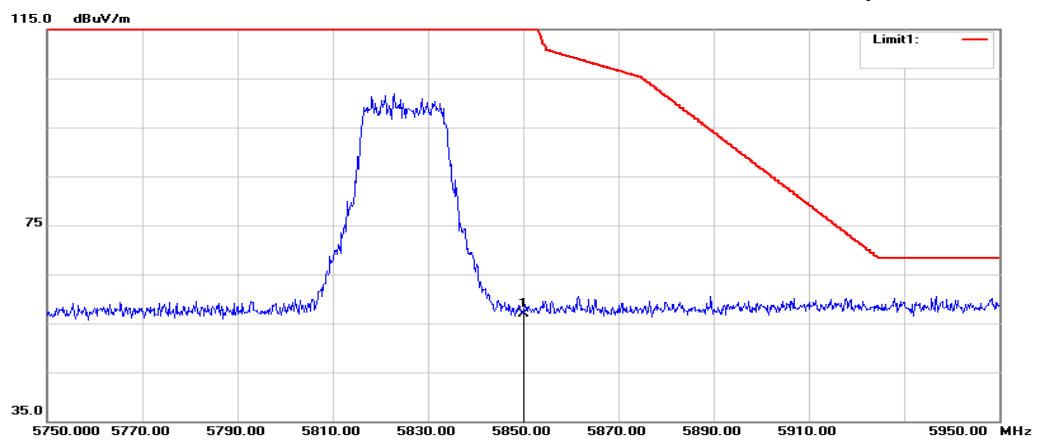

No.	Frequency (MHz)	Reading (dBuV)	Factor (dB/m)	Result (dBuV/m)	Limit (dBuV/m)	Margin (dB)	Remark	Antenna Polar
1	5850.000	54.35	4.78	59.13	122.20	-63.07	Peak	Vertical
1	5850.000	52.16	4.78	56.94	122.20	-65.26	Peak	Horizontal

IEEE 802.11n HT 40 MHz mode/ 5755MHz

Detector mode: Peak

Polarity: Vertical

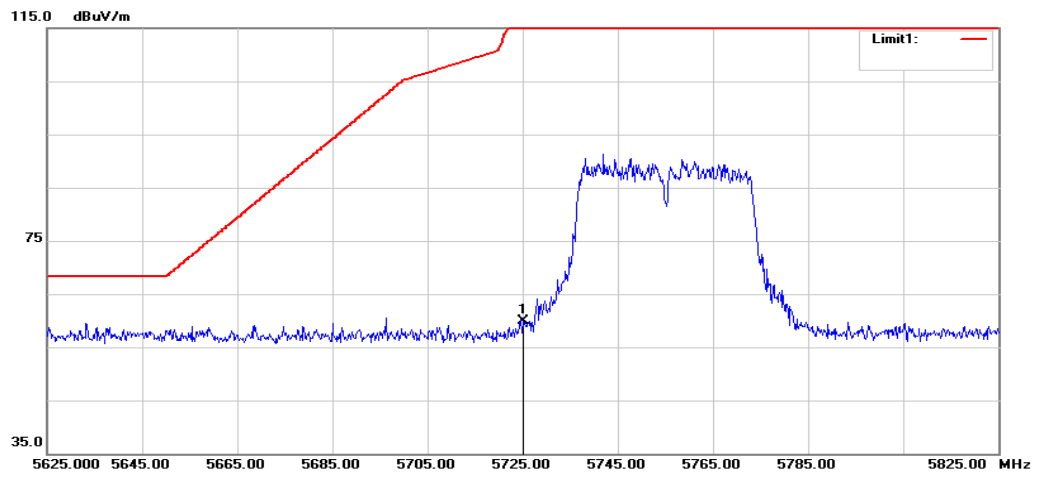

Detector mode: Peak

Polarity: Horizontal

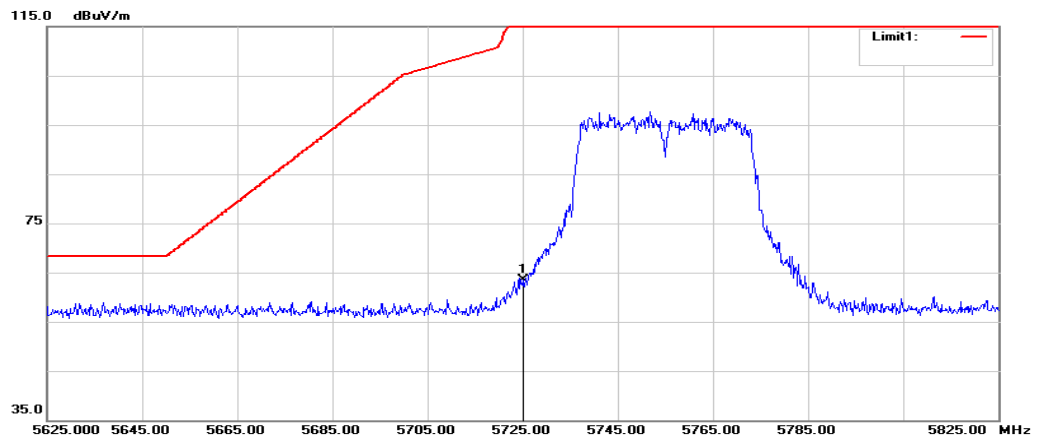

No.	Frequency (MHz)	Reading (dBuV)	Factor (dB/m)	Result (dBuV/m)	Limit (dBuV/m)	Margin (dB)	Remark	Antenna Polar
1	5725.000	55.47	4.38	59.85	122.20	-62.35	Peak	Vertical
1	5725.000	59.14	4.38	63.52	122.20	-58.68	Peak	Horizontal

IEEE 802.11n HT 40 MHz mode / 5795MHz

Detector mode: Peak

Polarity: Vertical

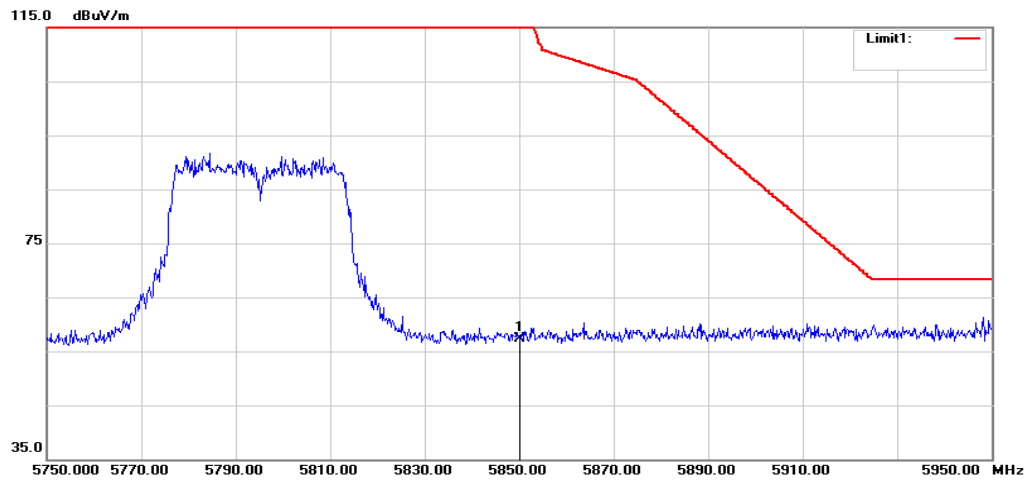

Detector mode: Peak

Polarity: Horizontal

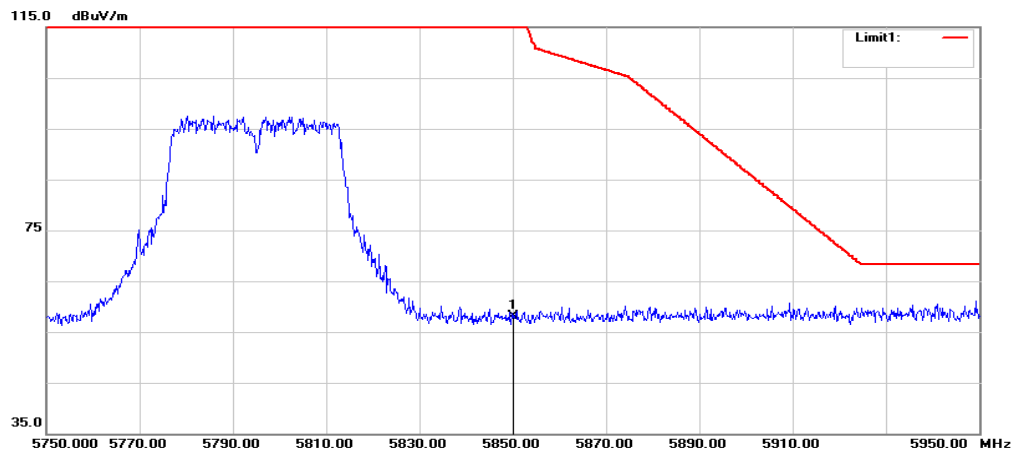

No.	Frequency (MHz)	Reading (dBuV)	Factor (dB/m)	Result (dBuV/m)	Limit (dBuV/m)	Margin (dB)	Remark	Antenna Polar
1	5850.000	52.48	4.78	57.26	122.20	-64.94	Peak	Vertical
1	5850.000	53.26	4.78	58.04	122.20	-64.16	Peak	Horizontal

IEEE 802.11ac 80 mode / 5775MHz

Detector mode: Peak

Polarity: Vertical

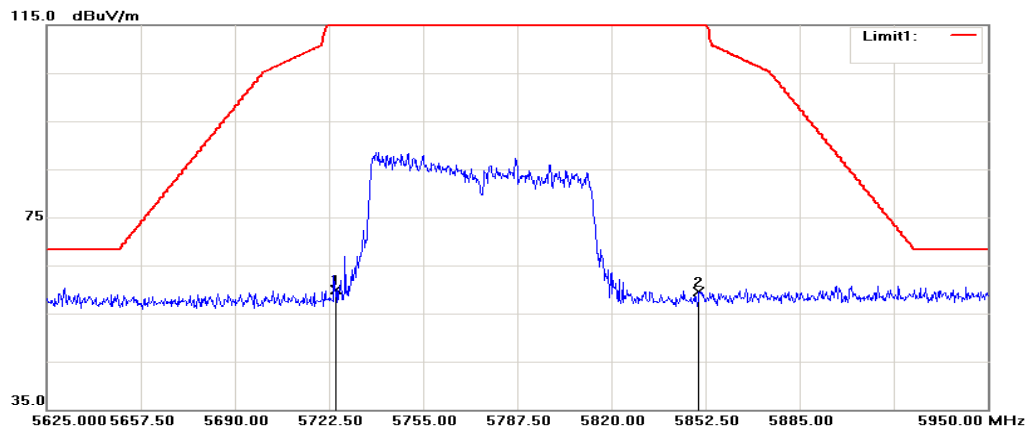

Detector mode: Peak

Polarity: Horizontal



No.	Frequency (MHz)	Reading (dBuV)	Factor (dB/m)	Result (dBuV/m)	Limit (dBuV/m)	Margin (dB)	Remark	Antenna Polar
1	5725.000	55.55	4.38	59.93	122.20	-62.27	Peak	Vertical
2	5850.000	54.77	4.78	59.55	122.20	-62.65	Peak	Vertical
1	5725.000	60.00	4.38	64.38	122.20	-57.82	Peak	Horizontal
2	5850.000	52.89	4.78	57.67	122.20	-64.53	Peak	Horizontal

8. EMISSION BANDWIDTH

8.1. LIMITS

For purposes of this subpart the emission bandwidth shall be determined by measuring the width of the signal between two points, one below the carrier center frequency and one above the carrier center frequency, that are 26 dB down relative to the maximum level of the modulated carrier. Determination of the emissions bandwidth is based on the use of measurement instrumentation employing a peak detector function with an instrument resolution bandwidth approximately equal to 1.0 percent of the emission bandwidth of the device under measurement.

Within the 5.725-5.85 GHz band, the minimum 6 dB bandwidth of U-NII devices shall be at least 500 kHz.

8.2. TEST PROCEDURES

- 1) The RF output of EUT was connected to the spectrum analyzer by RF cable and attenuator. The path loss was compensated to the results for each measurement.
- 2) Set to the maximum power setting and enable the EUT transmit continuously.
- 3) For 26dB bandwidth Measurement, the spectrum analyzer's resolution bandwidth (RBW) = approximately 1%EBW, VBW \geq 3RBW , Detector = Peak, Trace mode = max hold, Span > 26 dB bandwidth and Sweep time = auto
- 4) Mark the peak frequency and -26dB (upper and lower) frequency.
- 5) For 6 Bandwidth Measurement, the spectrum analyzer's resolution bandwidth (RBW) =100kHz VBW = 300 kHz, Detector = Peak, Trace mode = max hold.
- 6) Mark the peak frequency and -6dB (upper and lower) frequency.
- 7) For 99% Occupied Bandwidth Measurement, the spectrum analyzer's resolution bandwidth (RBW) =1% to 5% of the OBW, VBW \geq 3RBW, Detector = Peak, Trace mode = max hold , Span= 1.5 times to 5 times the OBW.
- 8) Measure and record the worst results in the test report.

8.3. TEST SETUP

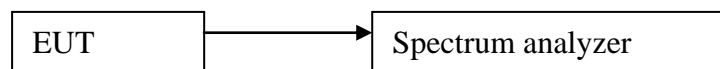

8.4. TEST RESULTS

26dB Bandwidth

802.11a mode	
Test Frequency (MHz)	26dB Bandwidth (MHz)
5180	24.83
5200	24.17
5240	24.46

802.11n HT20 mode	
Test Frequency (MHz)	26dB Bandwidth (MHz)
5180	24.53
5200	24.07
5240	24.73

802.11n HT40 mode	
Test Frequency (MHz)	26dB Bandwidth (MHz)
5190	49.35
5230	48.62

802.11ac 80 mode	
Test Frequency (MHz)	26dB Bandwidth (MHz)
5210	85.13

Test Results (plots) of Bandwidth

802.11a mode:

Channel 5180MHz

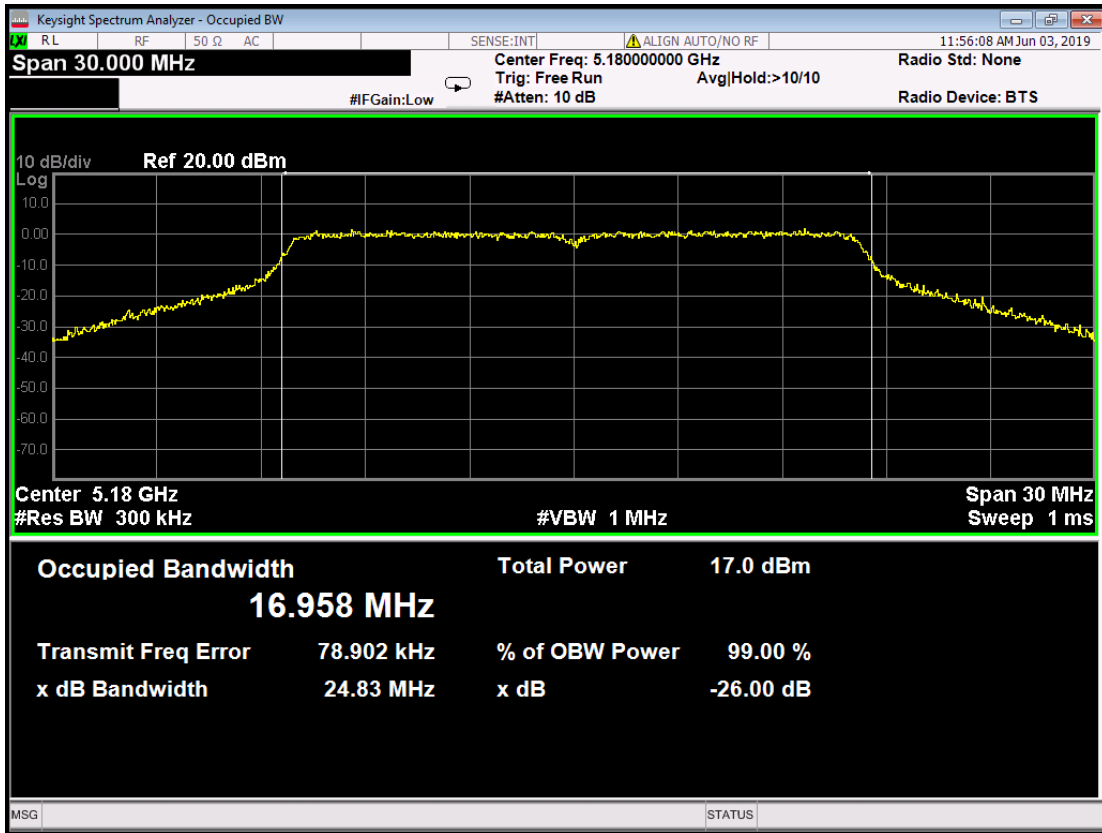

Channel 5200MHz

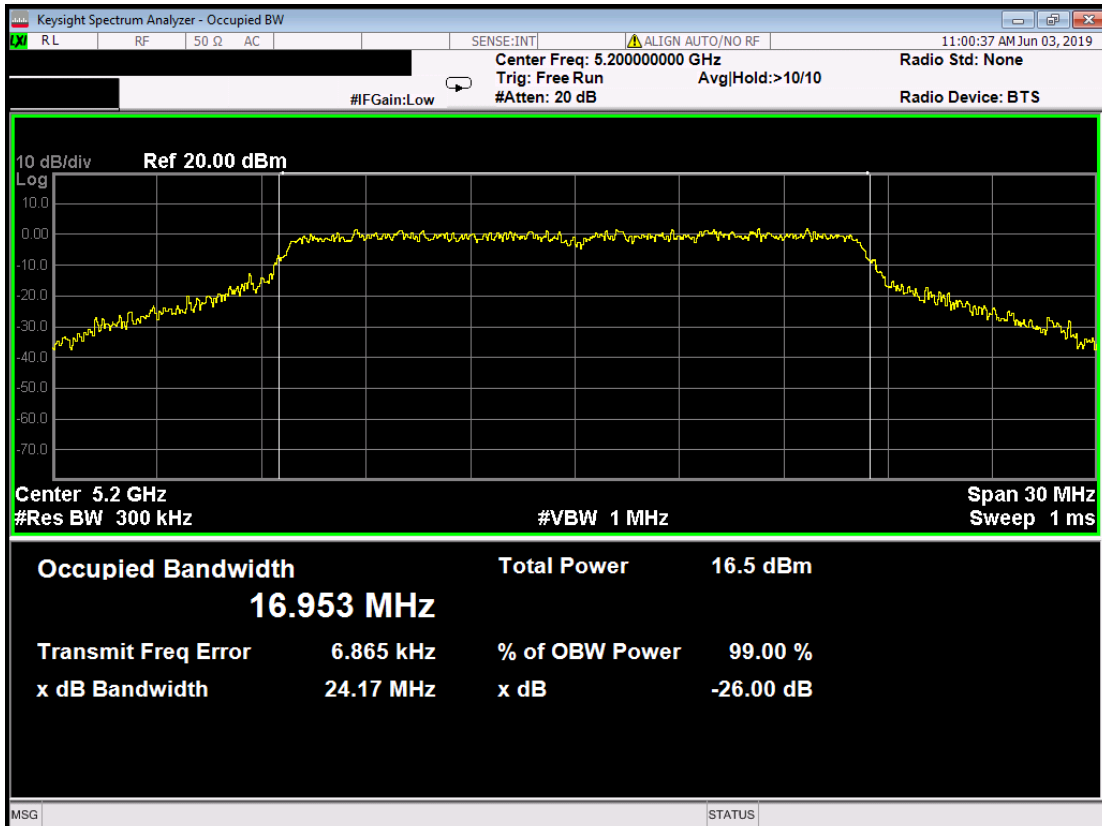

Channel 5240MHz

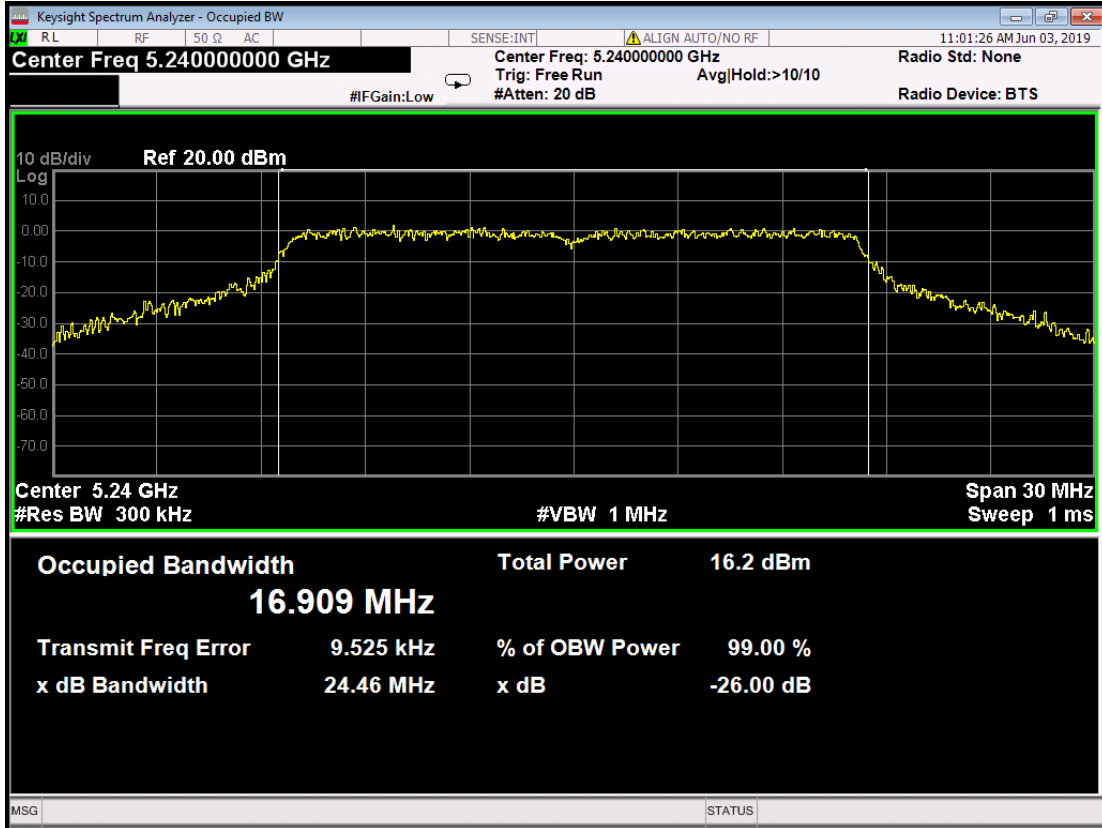

802.11n HT20 mode):
Channel 5180MHz

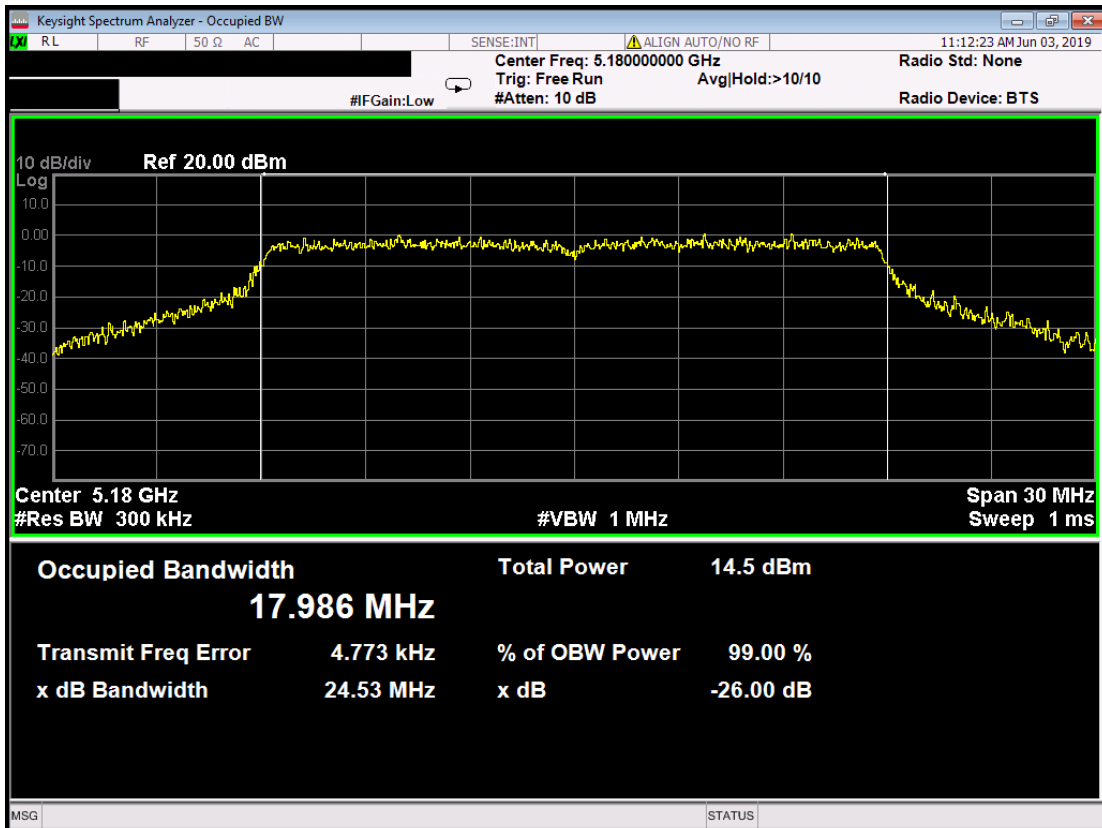

Channel 5200MHz

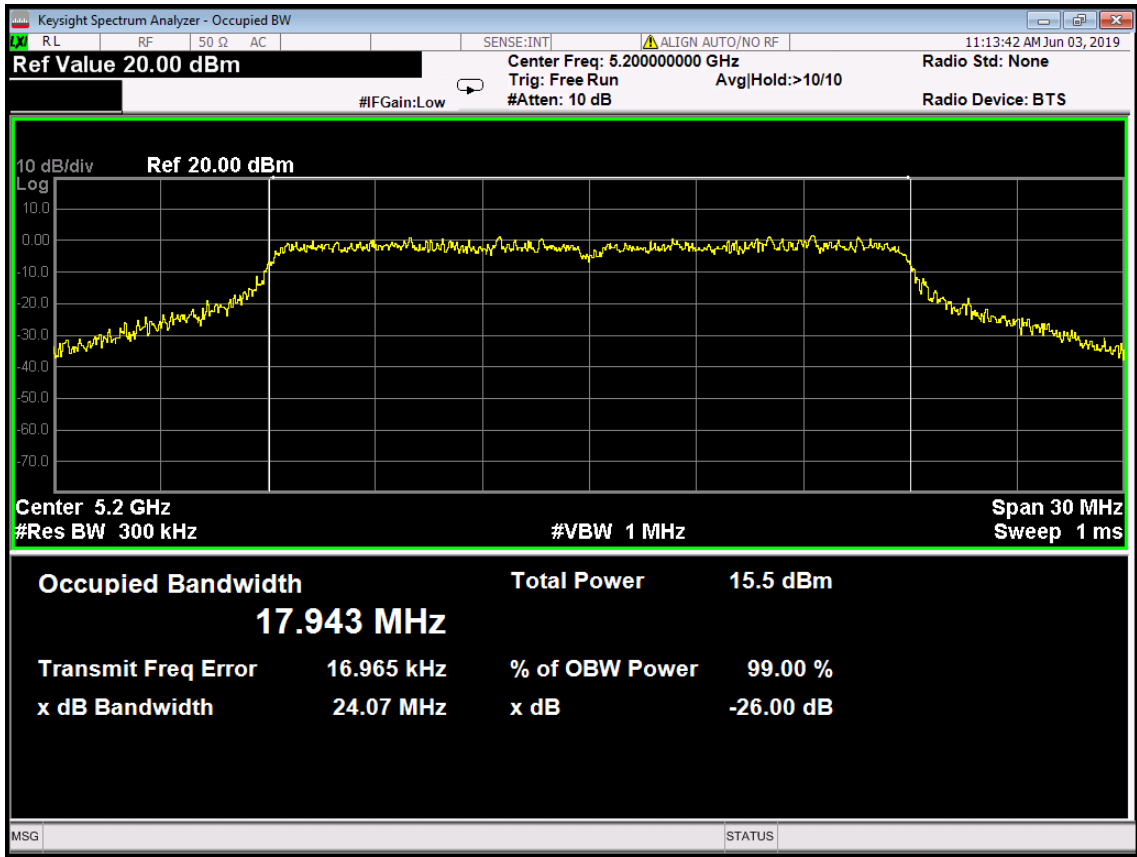

Channel 5240MHz

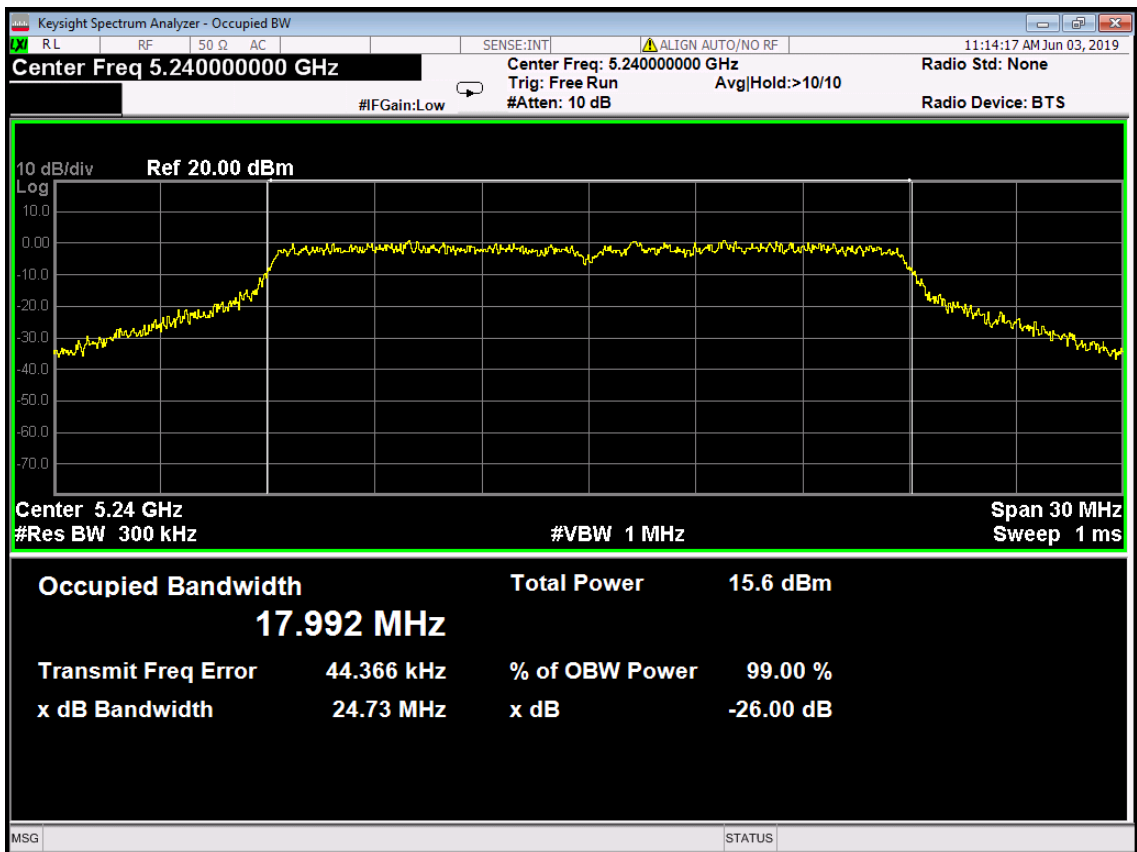

802.11n HT40 mode:
Channel 5190MHz

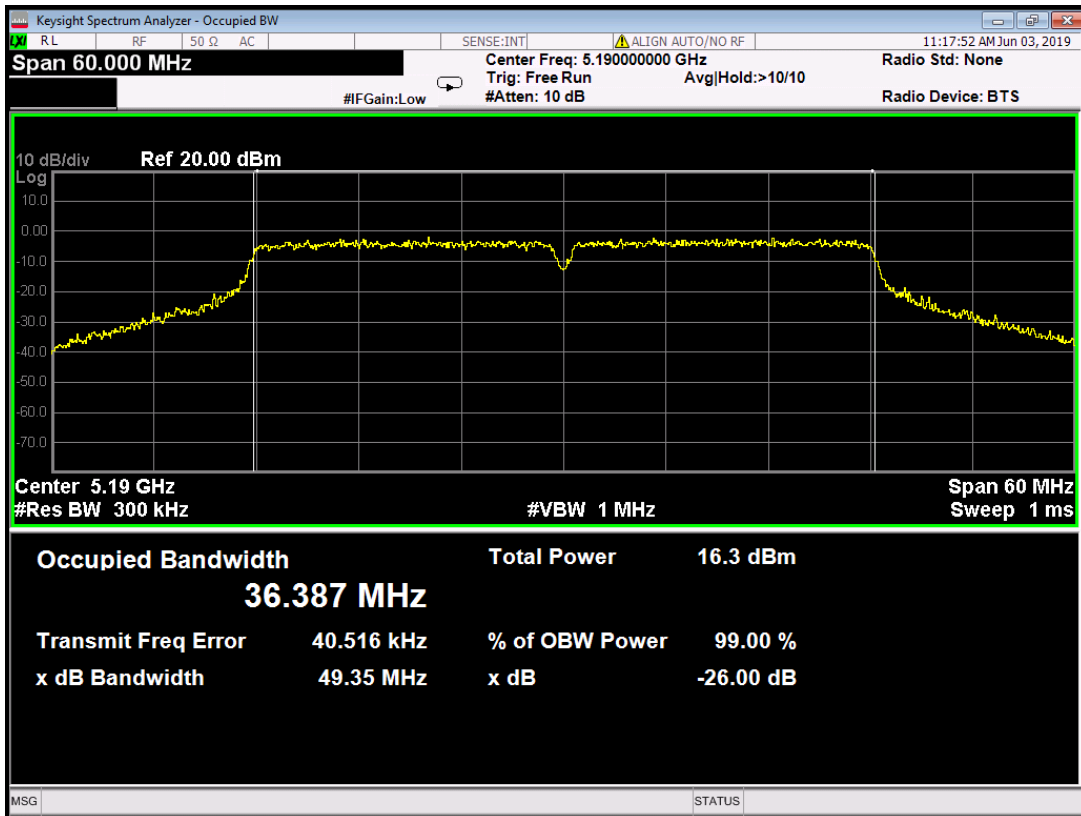

Channel 5230MHz

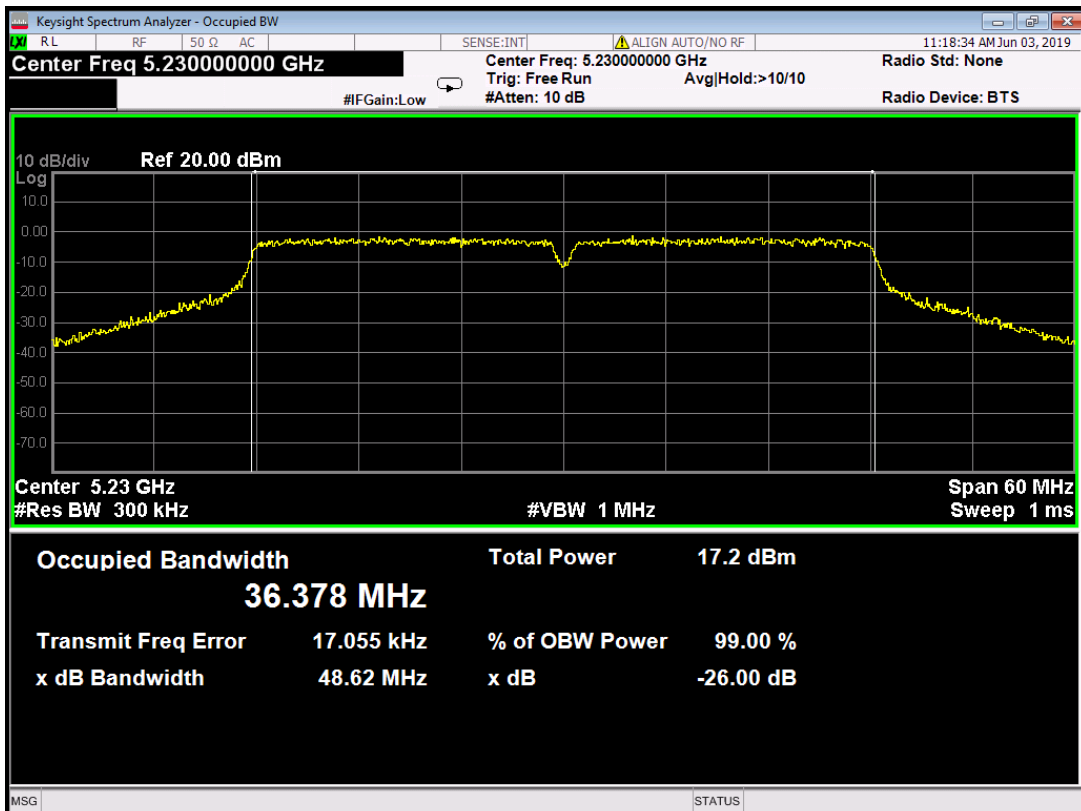

802.11ac 80 mode:
Channel 5210MHz

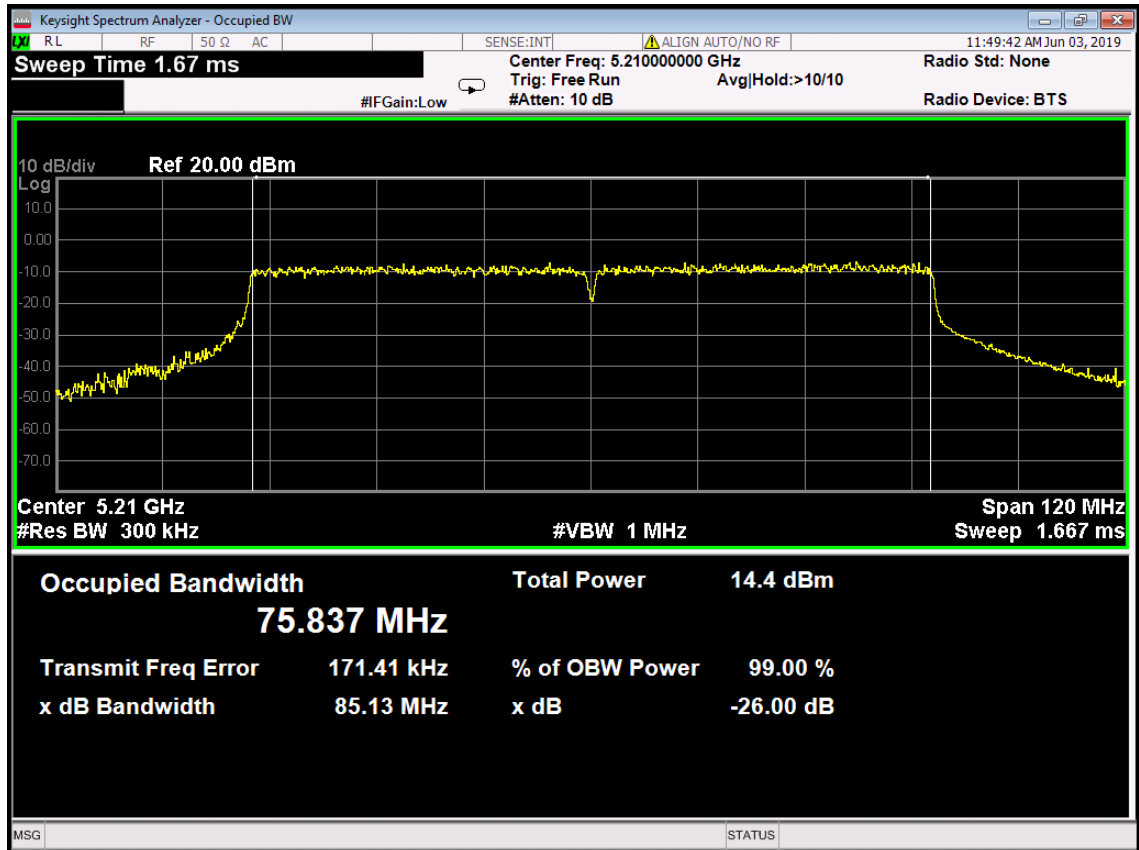

6dB Bandwidth

802.11a mode			
Frequency (MHz)	6dB Bandwidth (MHz)	Limit (kHz)	Result
5745	16.37	>500	PASS
5785	16.34		PASS
5825	16.34		PASS

802.11n HT20 mode			
Frequency (MHz)	6dB Bandwidth (MHz)	Limit (kHz)	Result
5745	17.57	>500	PASS
5785	17.52		PASS
5825	17.17		PASS

802.11n HT40 mode			
Frequency (MHz)	6dB Bandwidth (MHz)	Limit (kHz)	Result
5755	36.32	>500	PASS
5795	36.33		PASS

802.11ac 80 mode			
Frequency (MHz)	6dB Bandwidth (MHz)	Limit (kHz)	Result
5775	76.41	>500	PASS

802.11a mode:
Channel 5745MHz

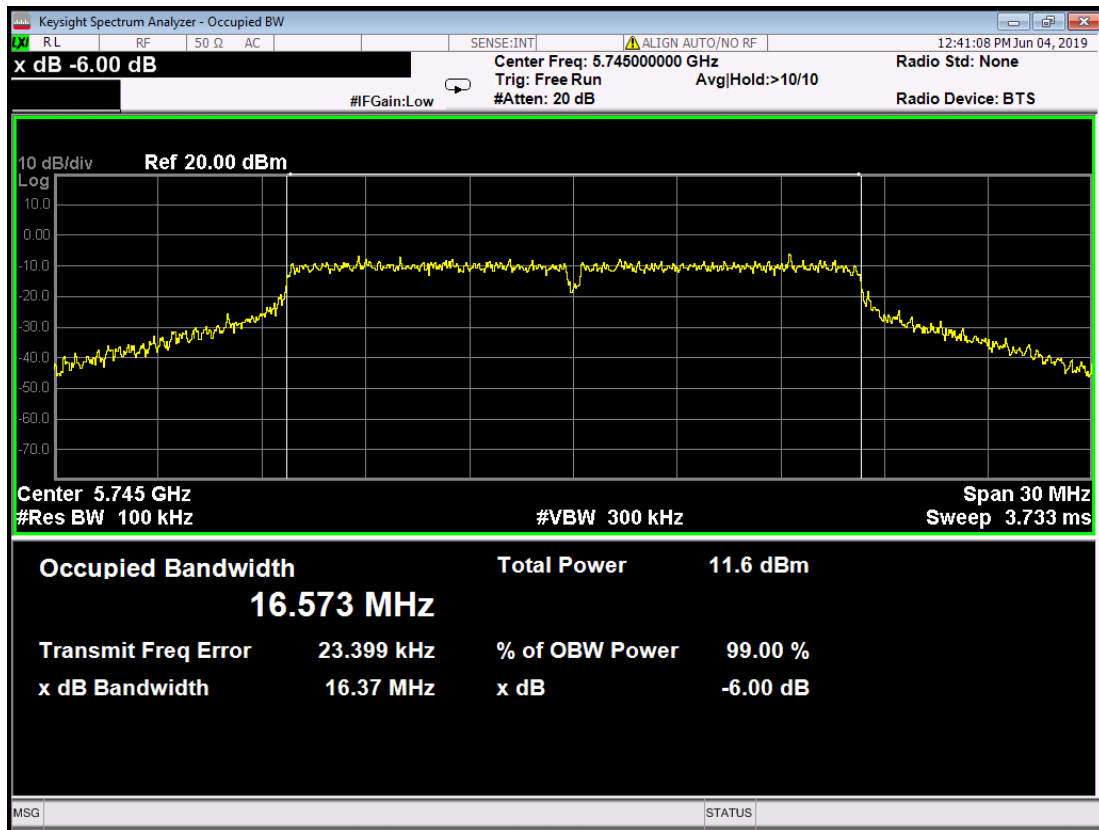

Channel 5785MHz

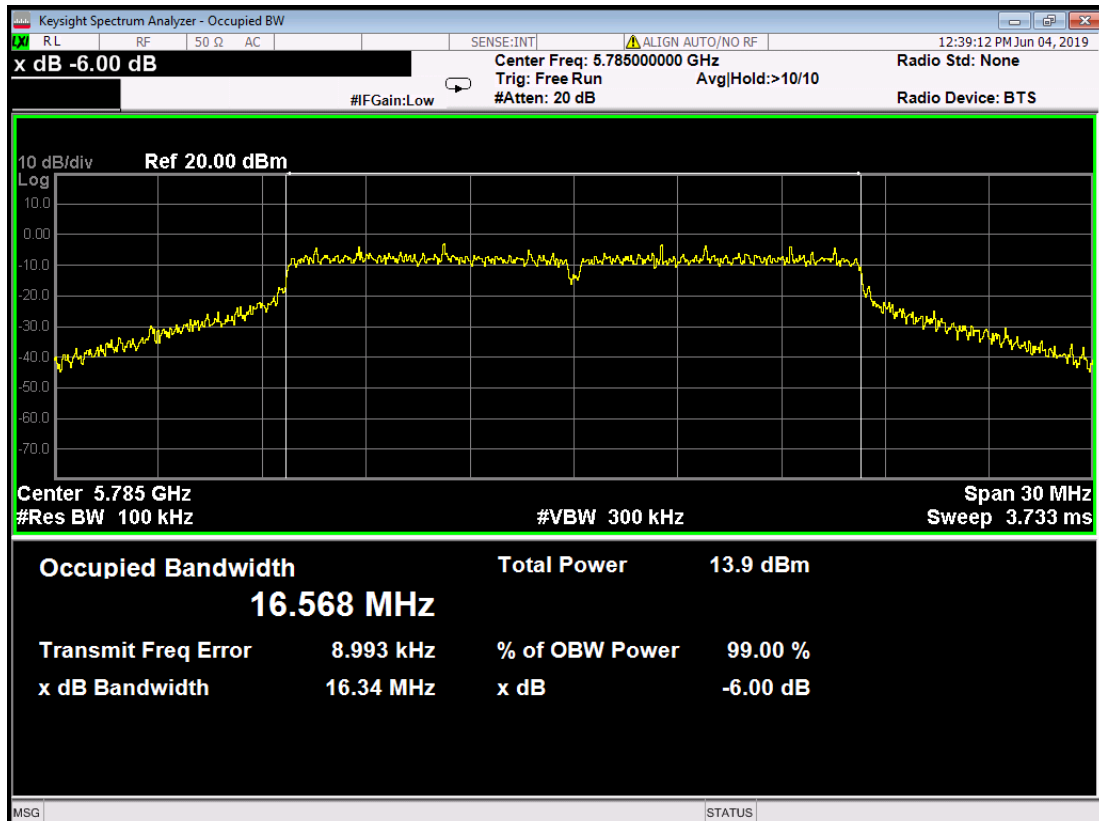

Channel 5825MHz

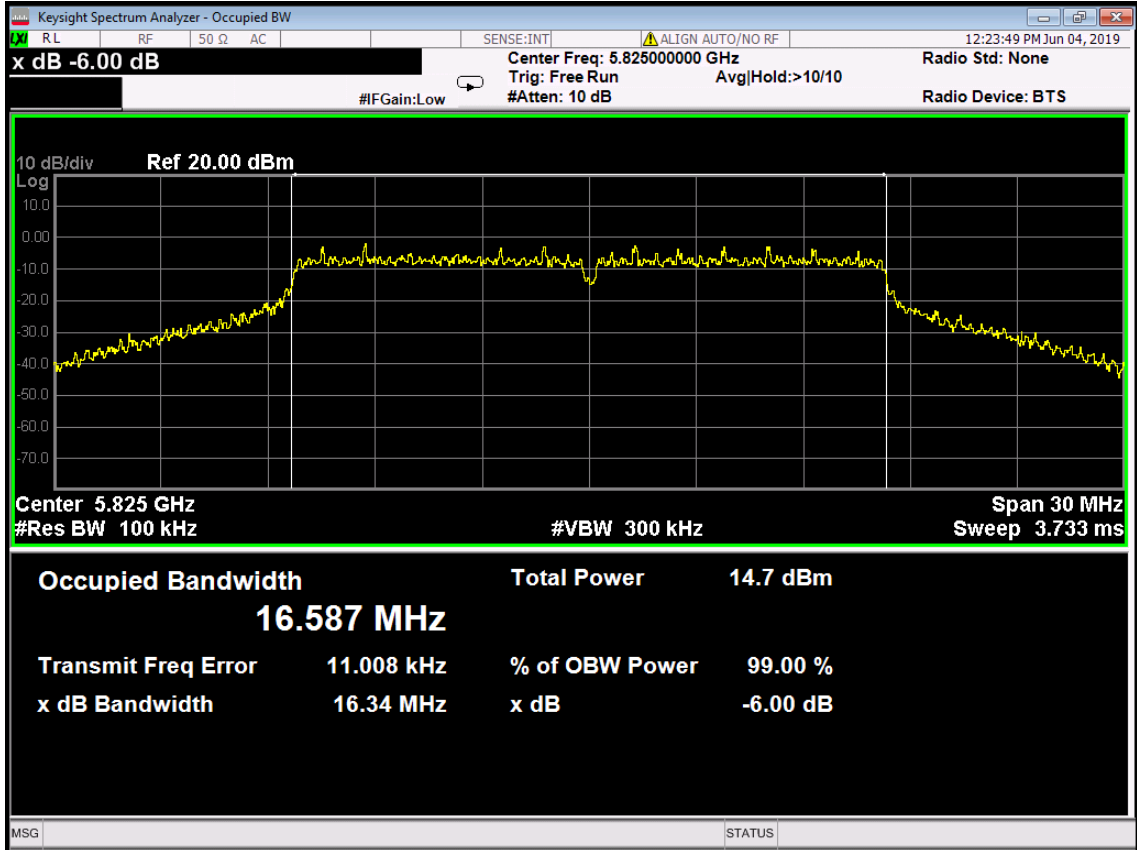

802.11n HT20 mode:
 Channel 5745MHz

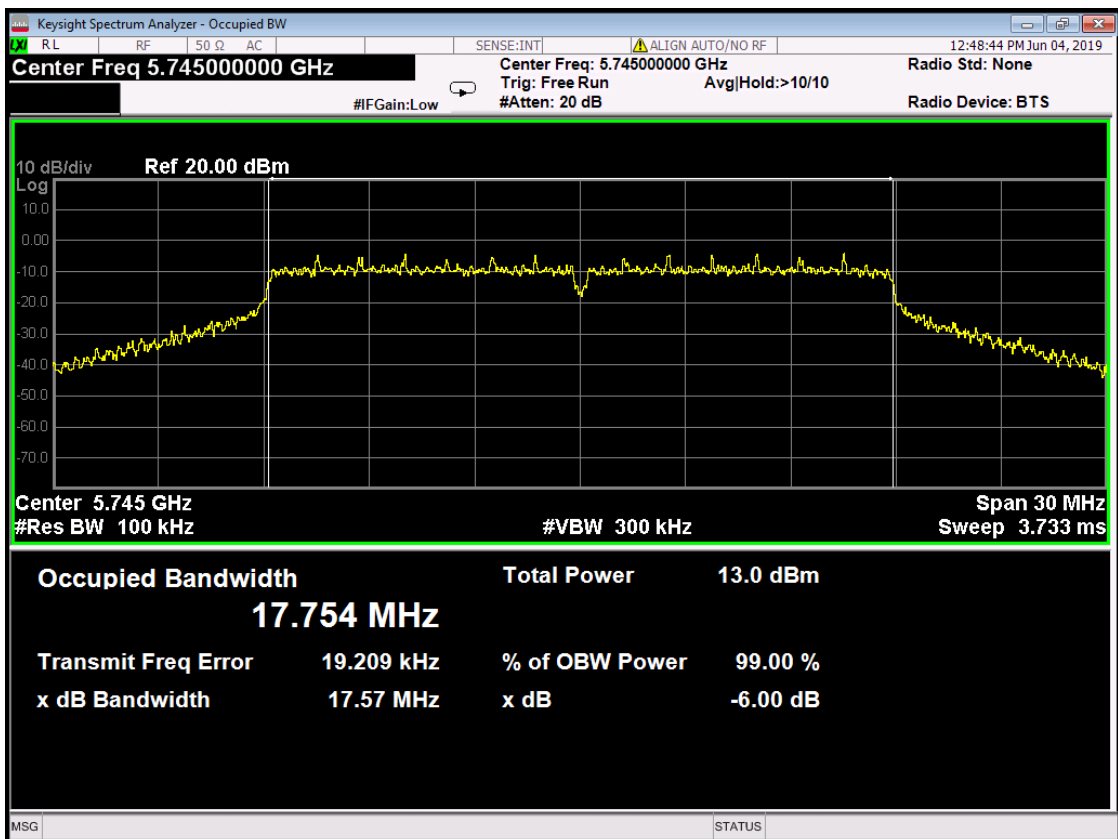

Channel 5785MHz

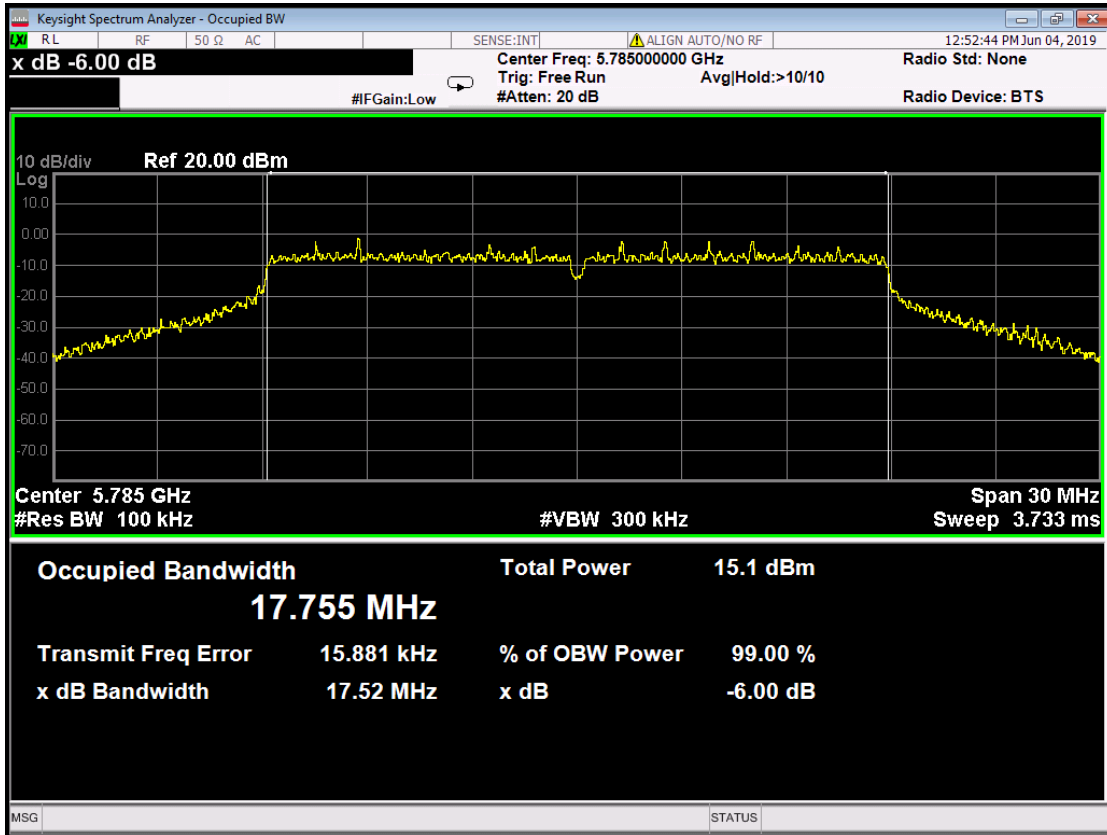

Channel 5825MHz

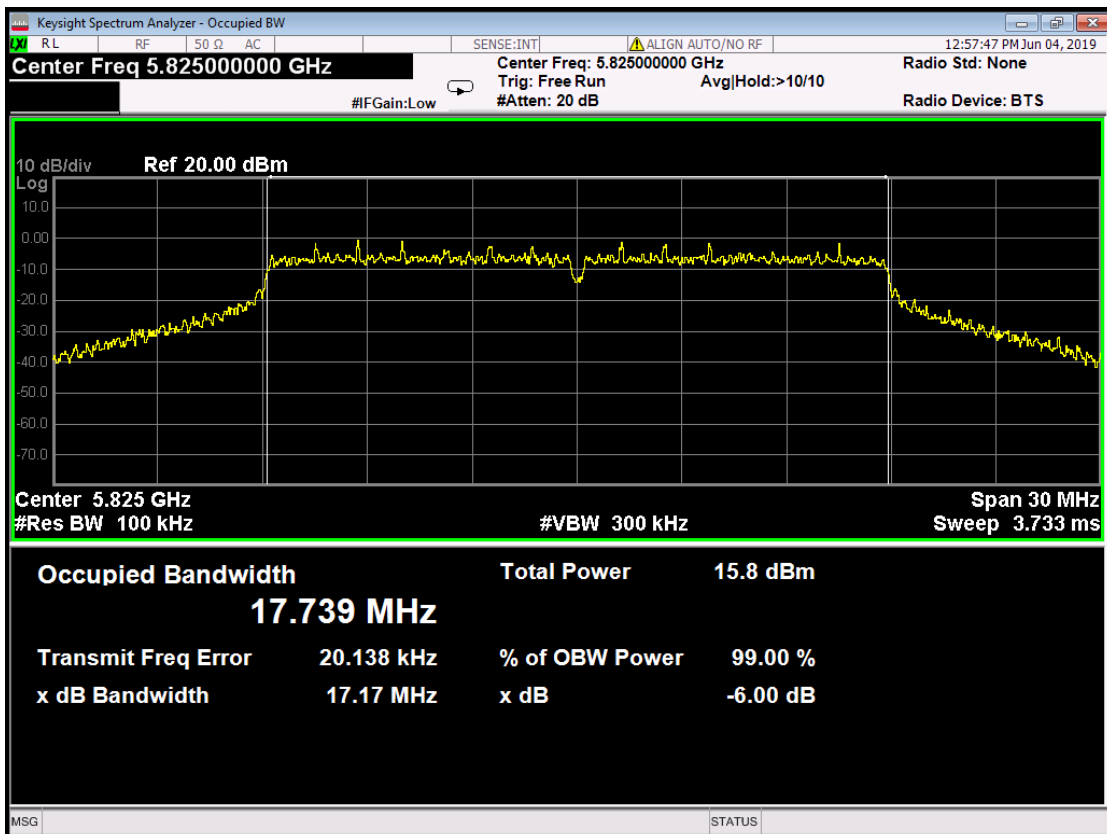

802.11n HT40 mode:
Channel 5755MHz

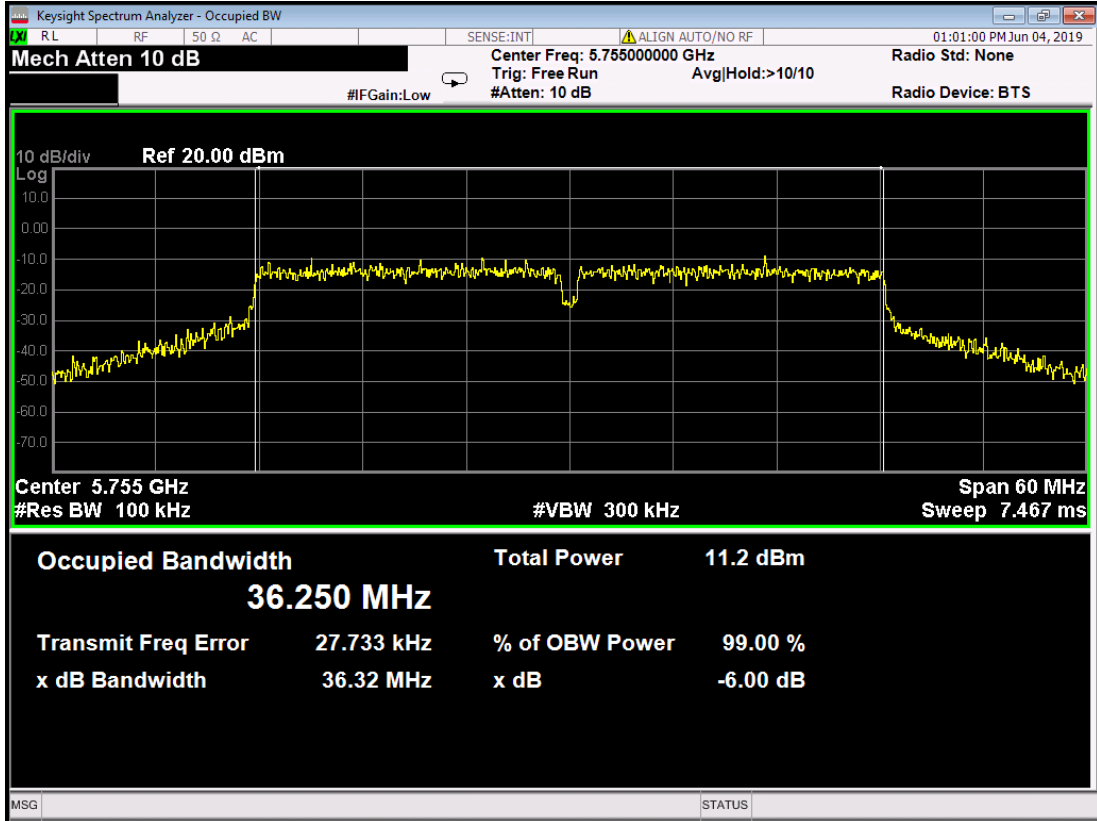

Channel 5795MHz

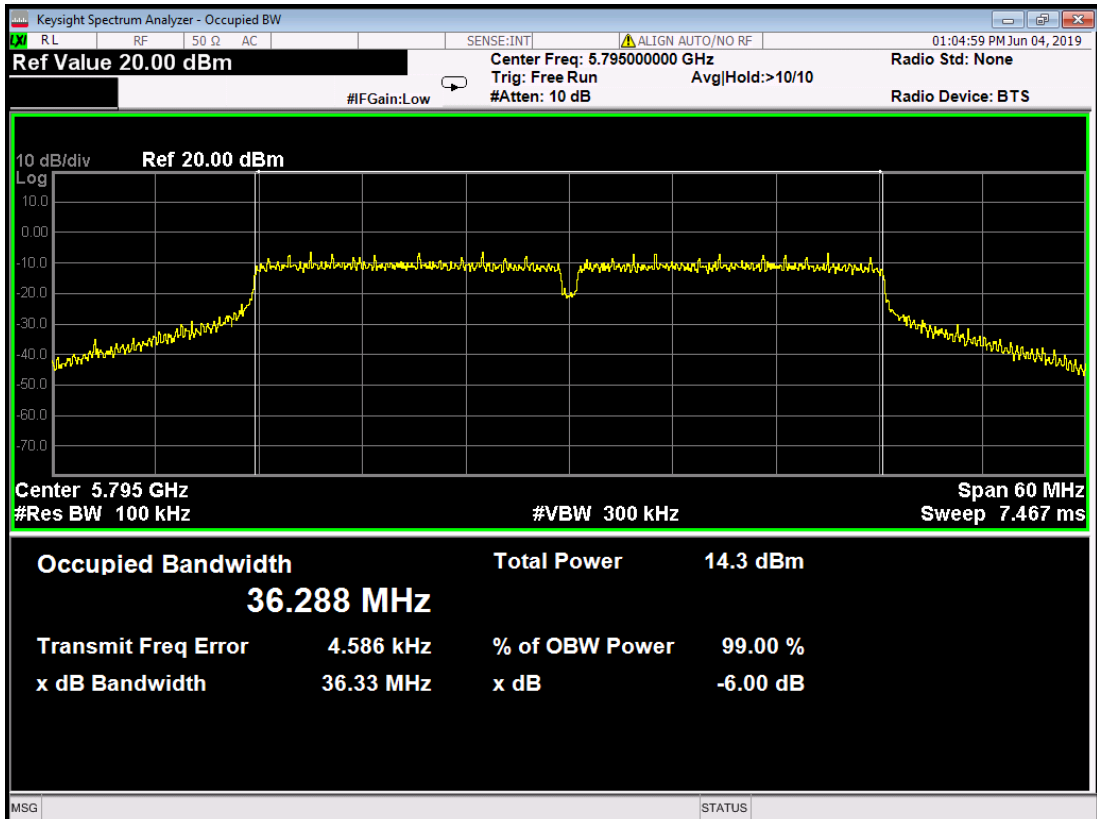

802.11ac 80 mode:
Channel 5775MHz

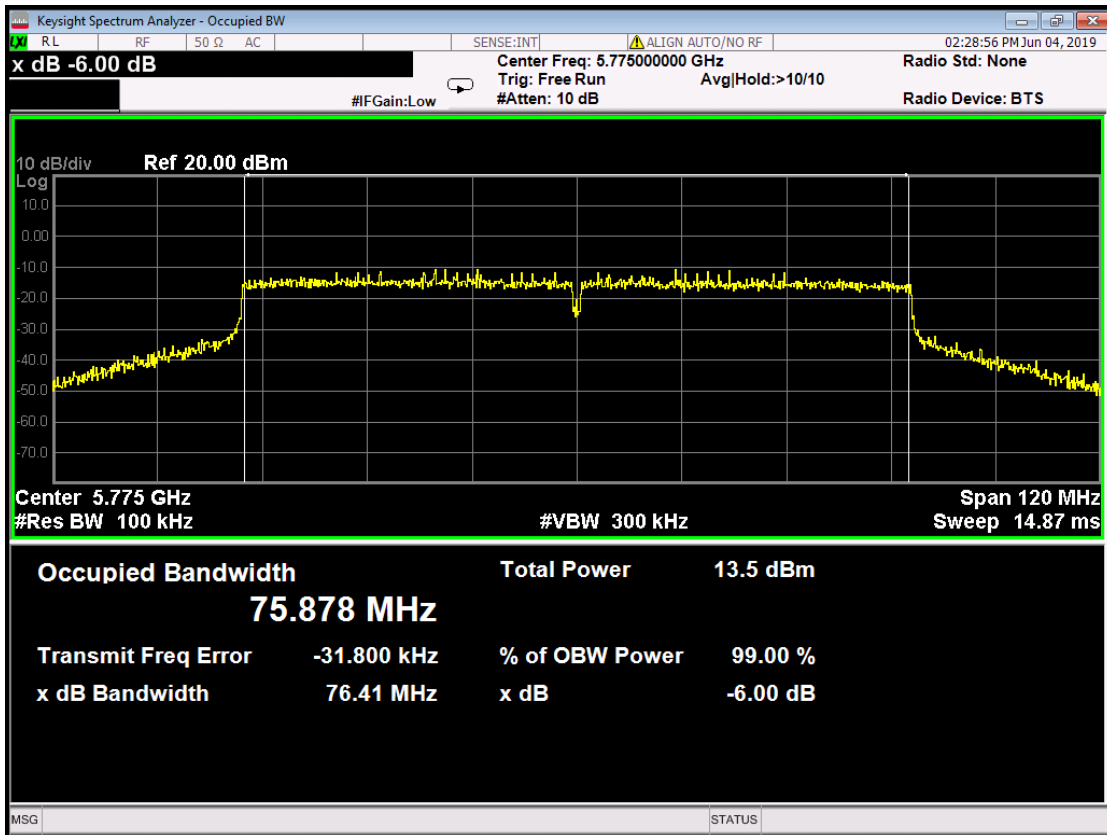

9. OUTPUT POWER

9.1. LIMITS

The FCC 15.407(a),The maximum conducted output power should not exceed:

Band	EUT Category	Limit
U-NII-1	<input type="checkbox"/> Outdoor Access Point	1 Watt (30 dBm) (Max. e.i.r.p \leq 125mW(21dBm) at any elevation angle above 30 degrees as measured from the horizon)
	<input type="checkbox"/> Fixed point-to-point Access device	1 Watt (30 dBm)
	<input checked="" type="checkbox"/> Indoor Access Point	1 Watt (30 dBm)
	<input type="checkbox"/> Mobile and portable client device	250mW (24 dBm)
U-NII-2A	<input type="checkbox"/>	250mW (24 dBm) or 11dBm+10logB* Whichever is less.
U-NII-2C	<input type="checkbox"/>	250mW (24 dBm) or 11dBm+10logB* Whichever is less.
U-NII-3	<input checked="" type="checkbox"/>	1 Watt (30 dBm)

Note: B* is the 26 dB emission bandwidth in MHz.

9.2. TEST PROCEDURES

- 1) The RF output of EUT was connected to the broadband average RF power meter by RF cable and attenuator. The path loss was compensated to the results for each measurement.
- 2) Set to the maximum power setting and enable the EUT transmit continuously.
- 3) Measure the conducted output power and record the results in the test report.

9.3. TEST SETUP

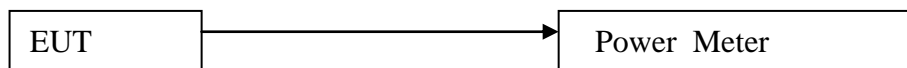

9.4. TEST RESULTS

Specified Limit of the Output Power

Test mode: IEEE 802.11a mode

Frequency (MHz)	26 bandwidth (B) (MHz)	10*Log(B) (dB)	11+10*Log(B) (dBm)	Maximum conducted output power limit (dBm)
5180	24.83	13.95	23.95	23.95
5200	24.17	13.83	23.83	23.83
5240	24.46	13.88	23.88	23.88

Test mode: IEEE 802.11n HT20 mode

Frequency (MHz)	26 bandwidth (B) (MHz)	10*Log(B) (dB)	11+10*Log(B) (dBm)	Maximum conducted output power limit (dBm)
5180	24.53	13.90	23.90	23.90
5200	24.07	13.81	23.81	23.81
5240	24.73	13.93	23.93	23.93

Test mode: IEEE 802.11n HT40 mode

Frequency (MHz)	26 bandwidth (B) (MHz)	10*Log(B) (dB)	11+10*Log(B) (dBm)	Maximum conducted output power limit (dBm)
5190	49.35	16.93	26.93	26.93
5230	48.62	16.87	26.87	26.87

Test mode: IEEE 802.11ac 80 mode

Frequency (MHz)	26 bandwidth (B) (MHz)	10*Log(B) (dB)	11+10*Log(B) (dBm)	Maximum conducted output power limit (dBm)
5210	85.13	19.30	29.30	29.30

Output Power

802.11a mode			
Frequency (MHz)	AVG Conducted Output Power (dBm)	Limit (dBm)	Result
5180	11.52	23.83	PASS
5200	11.97		PASS
5240	12.79		PASS
5745	7.01	30.00	PASS
5785	9.35		PASS
5825	9.74		PASS

802.11n HT20 mode			
Frequency (MHz)	AVG Conducted Output Power (dBm)	Limit (dBm)	Result
5180	10.76	23.81	PASS
5200	11.29		PASS
5240	12.19		PASS
5745	7.69	30.00	PASS
5785	9.97		PASS
5825	10.57		PASS

802.11n HT40 mode			
Frequency (MHz)	AVG Conducted Output Power (dBm)	Limit (dBm)	Result
5190	11.01	26.87	PASS
5230	13.00		PASS
5755	8.11	30.00	PASS
5795	9.62		PASS

802.11ac 80 mode			
Frequency (MHz)	AVG Conducted Output Power (dBm)	Limit (dBm)	Result
5210	7.83	29.30	PASS
5775	8.99	30.00	PASS

10. POWER SPECTRAL DENSITY

10.1.LIMITS

FCC 15.407(a)

The maximum power spectral density should not exceed:

Band	EUT Category	Limit
5150-5250	<input type="checkbox"/> Access Point (Master device)	17 dBm/MHz
	<input type="checkbox"/> Fixed point-to-point Access device	
	<input checked="" type="checkbox"/> Mobile and portable client device	11 dBm/MHz
5250-5350	<input type="checkbox"/>	11 dBm/MHz
5470-5725	<input type="checkbox"/>	11 dBm/MHz
5725-5850	<input checked="" type="checkbox"/>	30dBm/500kHz

If transmitting antennas of directional gain greater than 6dBi are used, both the peak transmits power and the peak power spectral density shall be reduced by the amount in dB that the directional gain of the antenna exceeds 6dBi.

10.2.TEST PROCEDURES

- Place the EUT on the table and set it in transmitting mode.
Remove the antenna from the EUT and then connect a low loss RF cable from the antenna port to the spectrum analyzer.
- For devices operating in the bands 5.15-5.25 GHz, Set the spectrum analyzer as RBW = 1MHz, VBW = 3MHz, Span >26dB bandwidth, Sweep=1ms
- For devices operating in the bands 5.725-5.85 GHz, Set the spectrum analyzer as RBW = 1MHz, VBW = 3MHz, Span >26dB bandwidth, Sweep=1ms
- Record the max. reading.
- Repeat the above procedure until the measurements for all frequencies are completed.

10.3. TEST SETUP

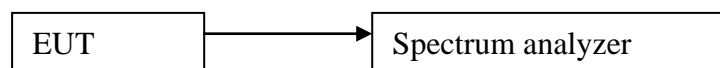

10.4.TEST RESULTS

802.11a mode			
Frequency (MHz)	PPSD (dBm)	Limit (dBm)	Result
5180	4.718	17	PASS
5200	4.523		PASS
5240	2.955		PASS
5745	-0.667	30	PASS
5785	1.604		PASS
5825	2.333		PASS

802.11n HT20 mode			
Frequency (MHz)	PPSD (dBm)	Limit (dBm)	Result
5180	3.977	17	PASS
5200	3.996		PASS
5240	3.100		PASS
5745	-0.569	30	PASS
5785	1.577		PASS
5825	2.294		PASS

802.11n HT40 mode			
Frequency (MHz)	PPSD (dBm)	Limit (dBm)	Result
5190	2.528	17	PASS
5230	4.813		PASS
5755	-2.817	30	PASS
5795	-1.517		PASS

802.11ac 80 mode			
Frequency (MHz)	PPSD (dBm)	Limit (dBm)	Result
5210	-0.448	17	PASS
5775	-2.959		PASS

802.11a mode:
Channel 5180MHz

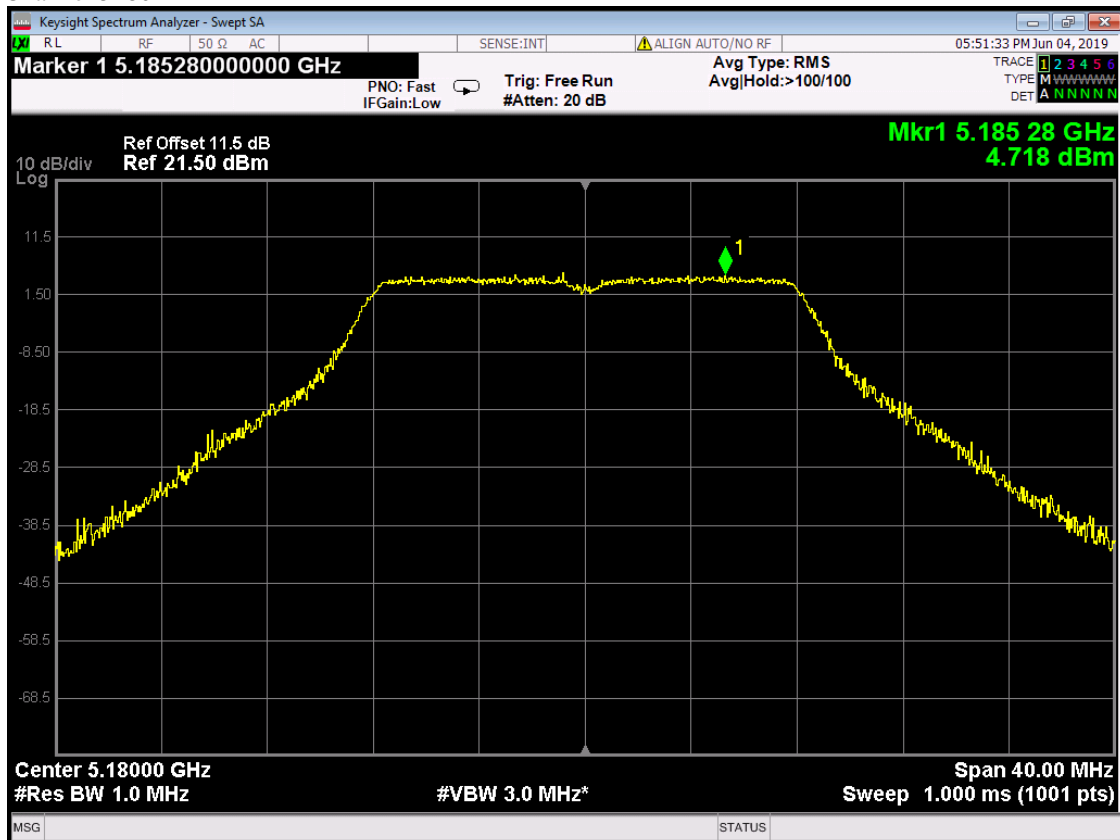

Channel 5200MHz

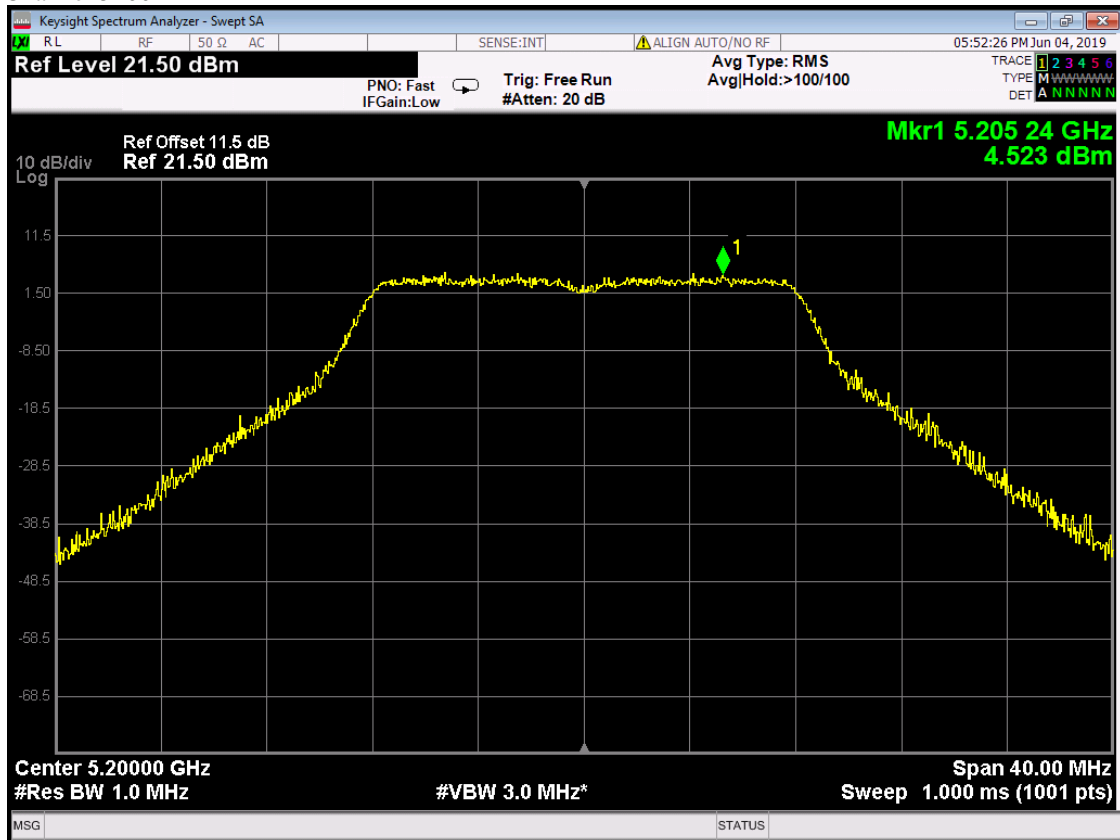

Channel 5240MHz

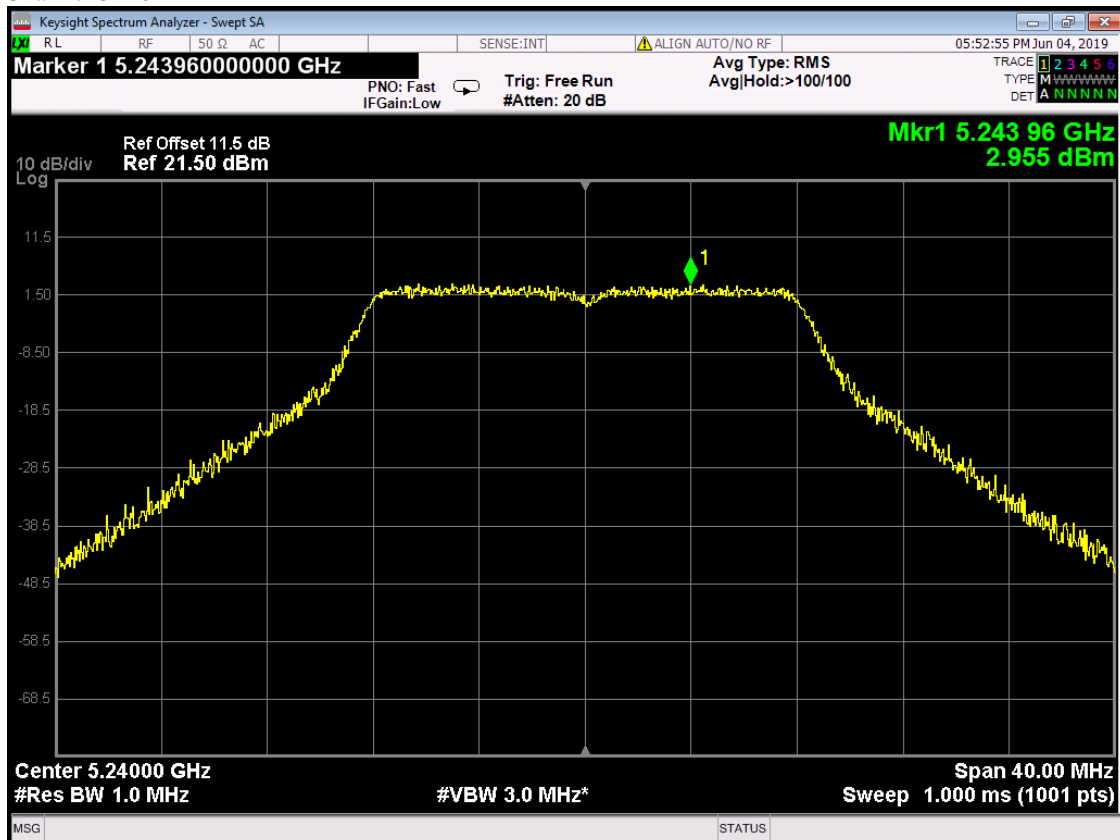

Channel 5745MHz

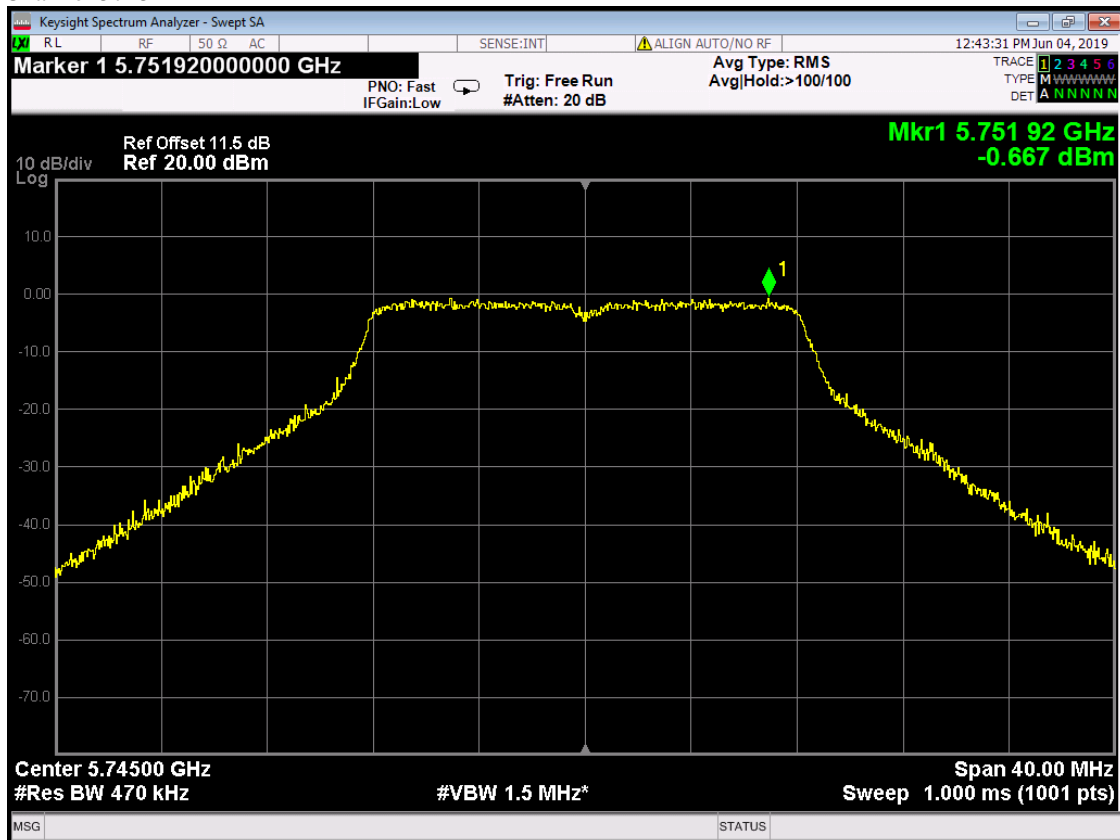

Channel 5785MHz

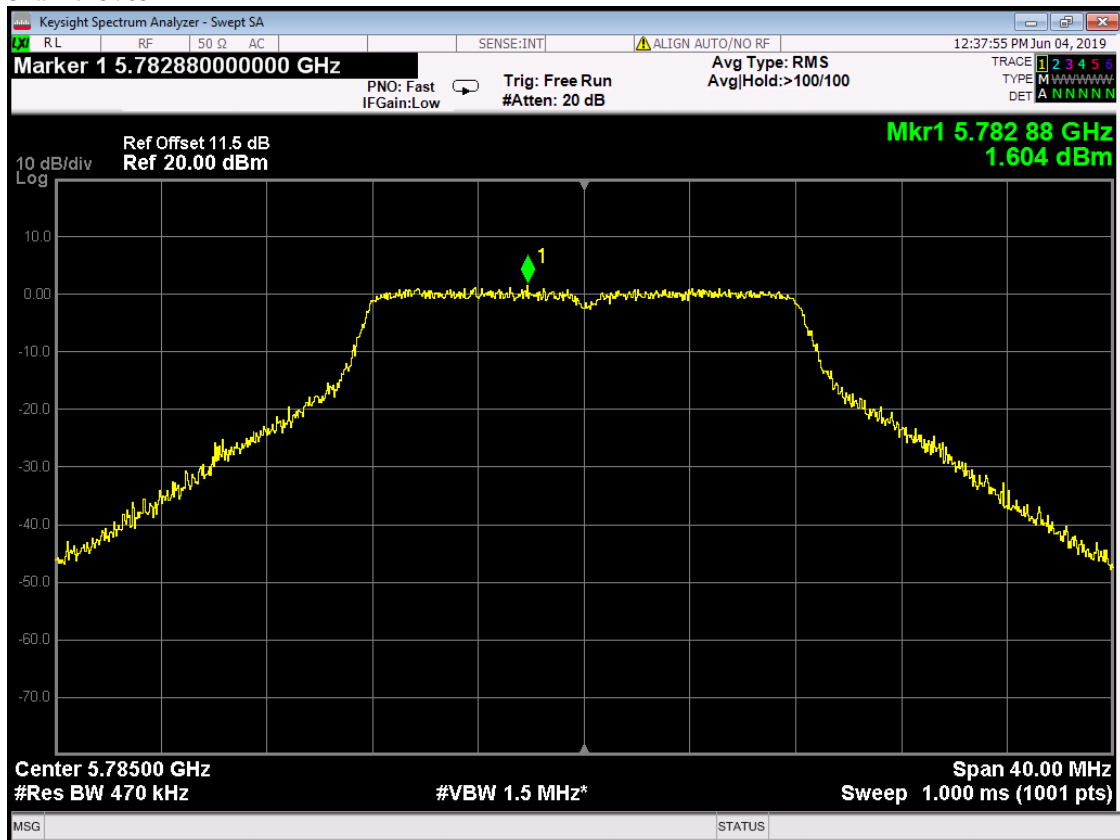

Channel 5825MHz

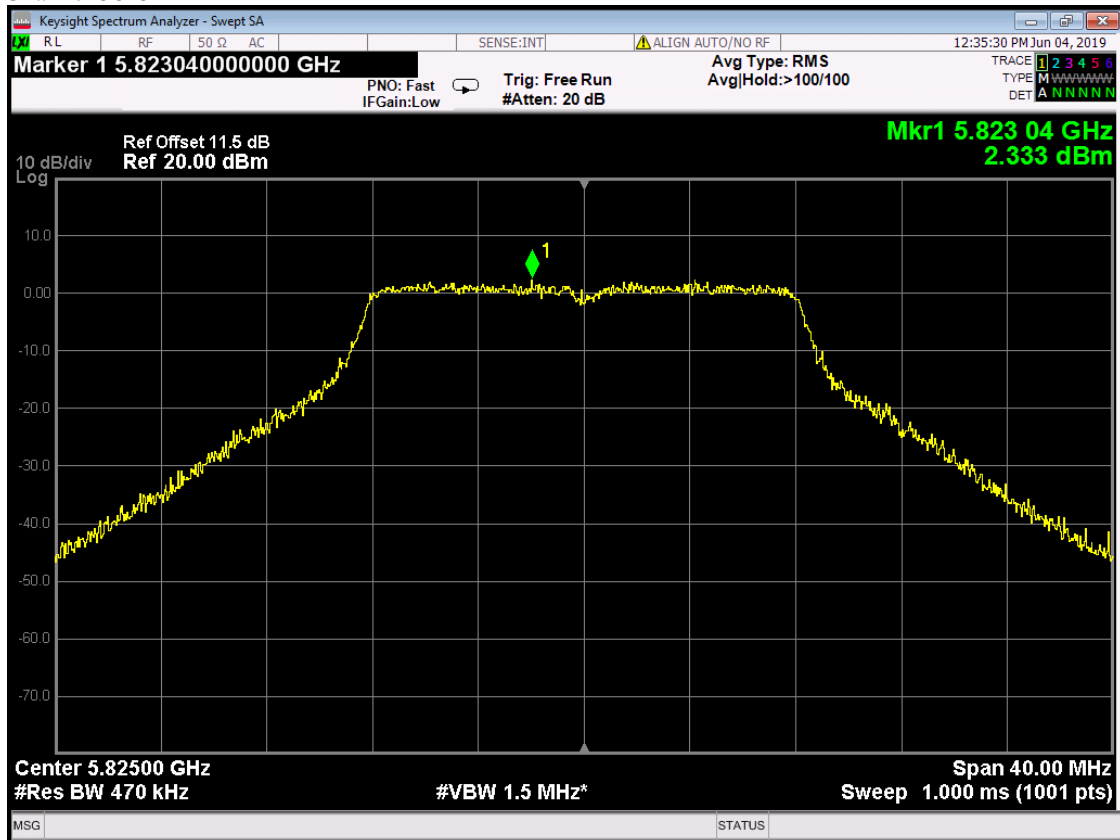

802.11HT 20 mode:
Channel 5180MHz

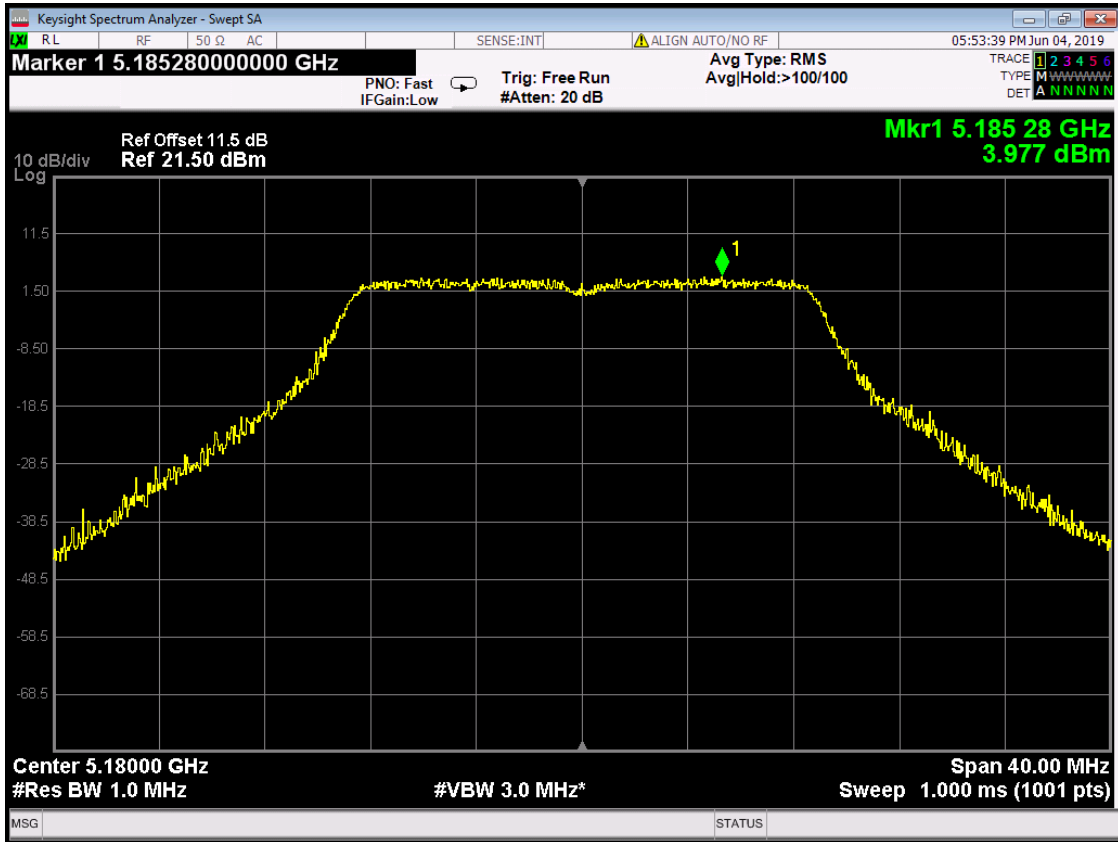

Channel 5200MHz

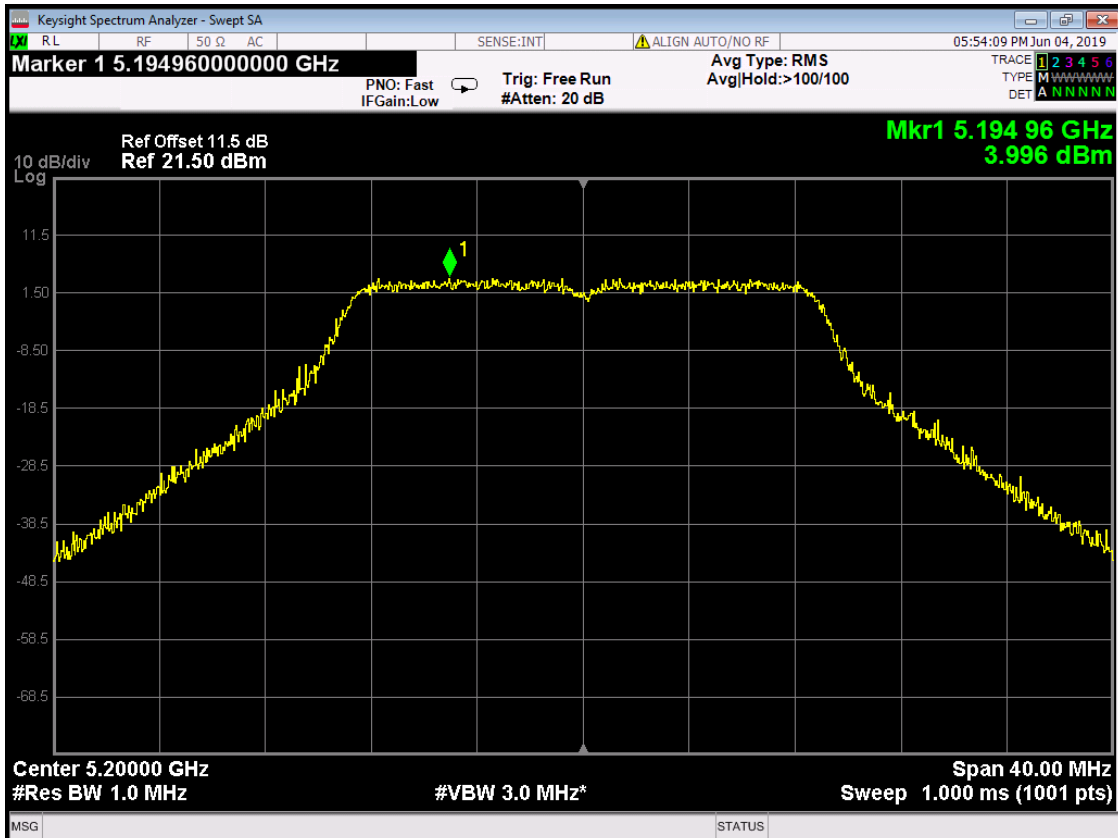

Channel 5240MHz

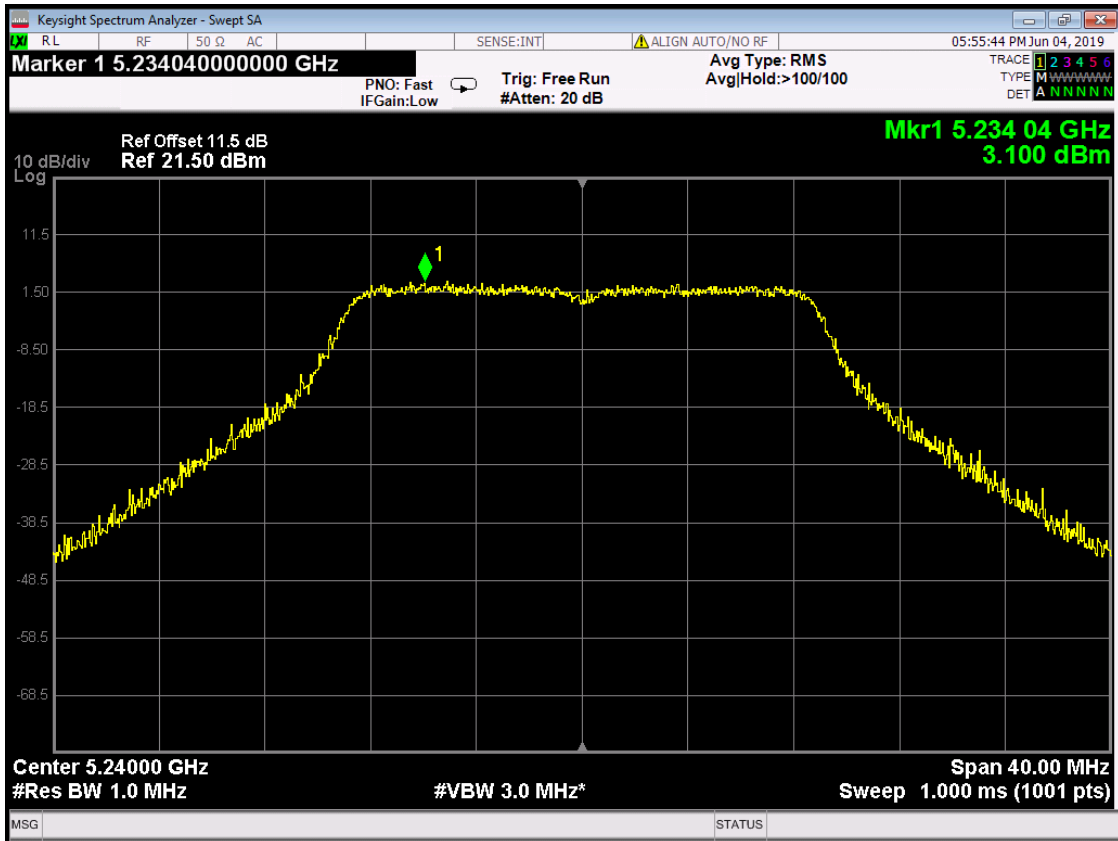

Channel 5745MHz

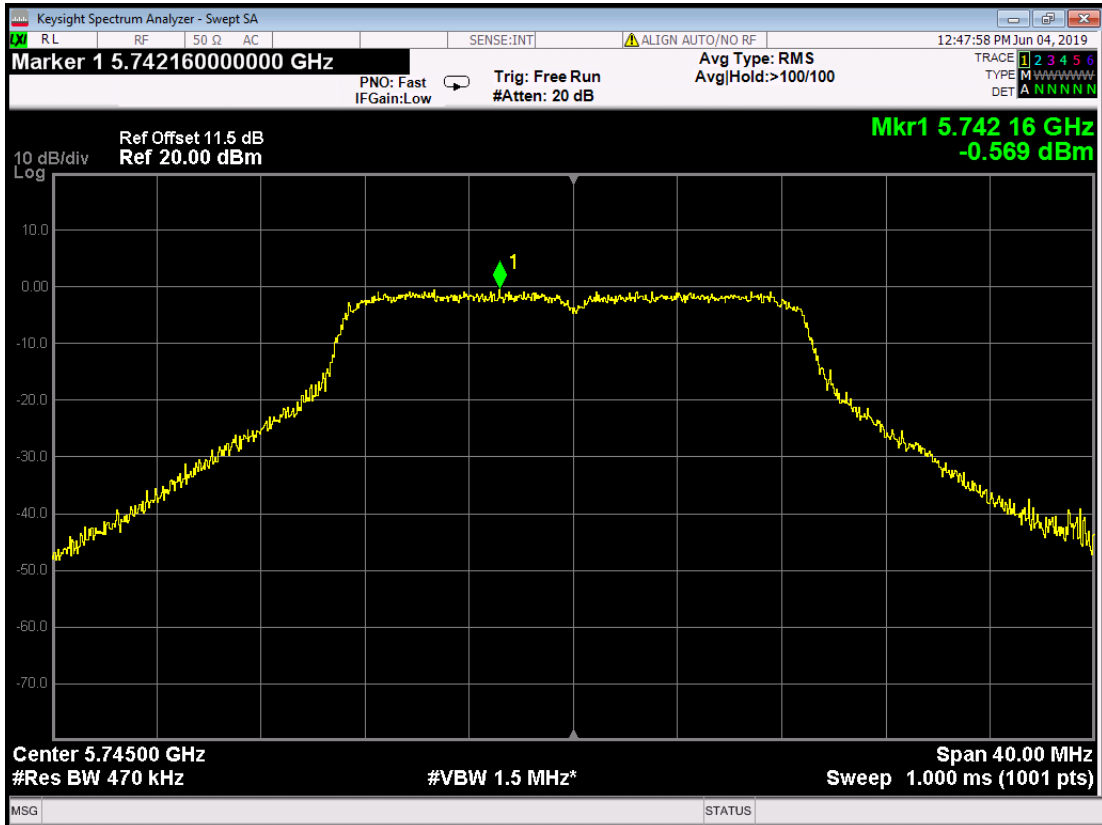

Channel 5785MHz

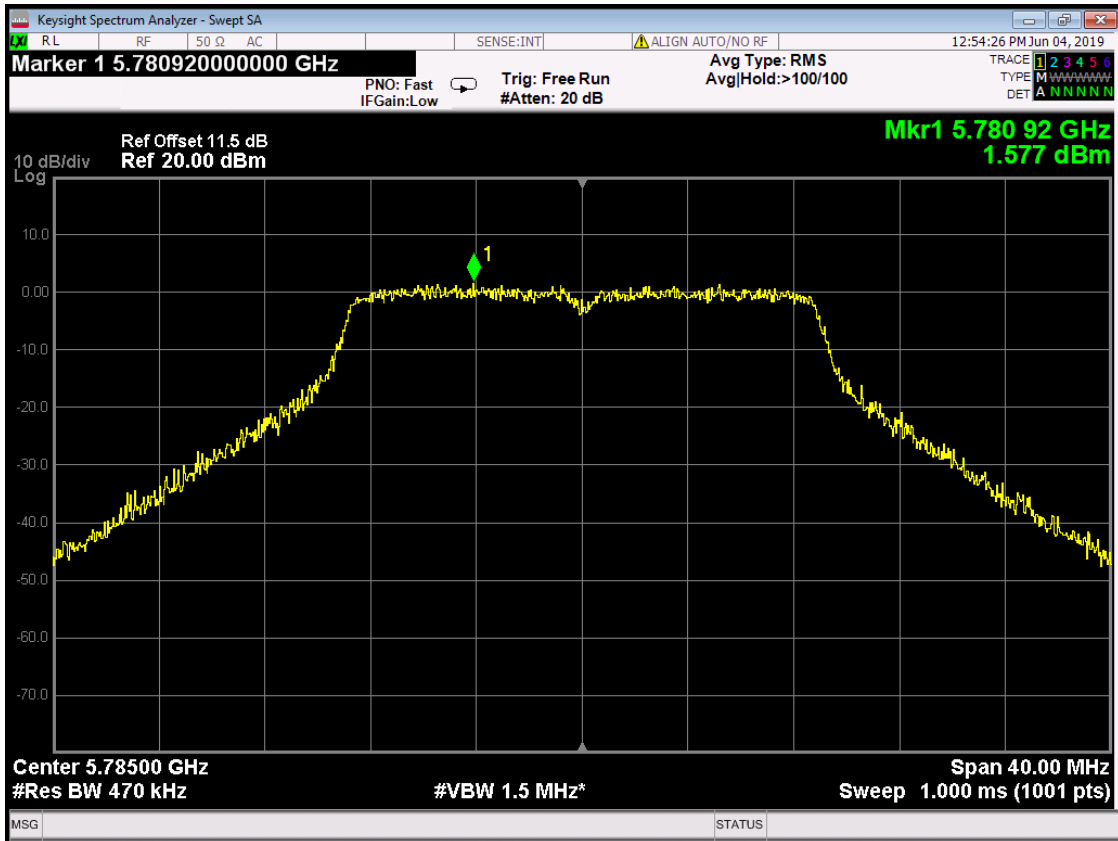

Channel 5825MHz

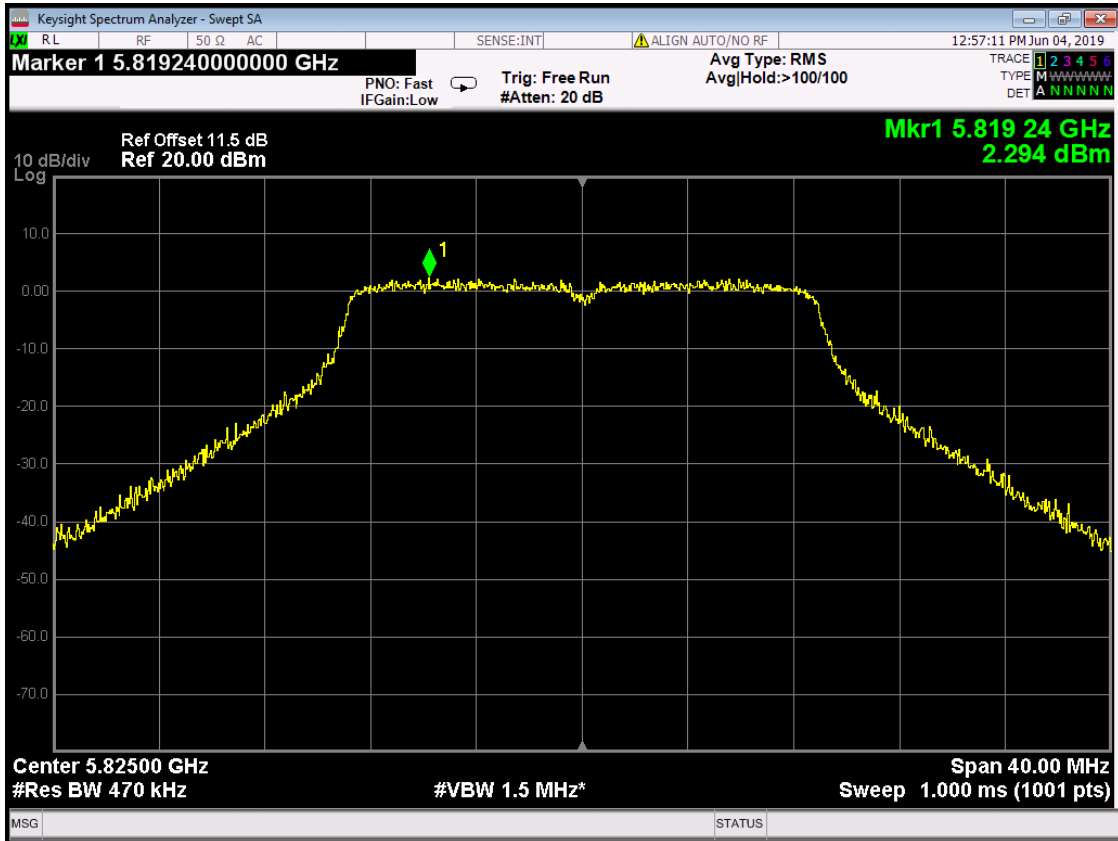

802.11HT 40 mode:
Channel 5190MHz

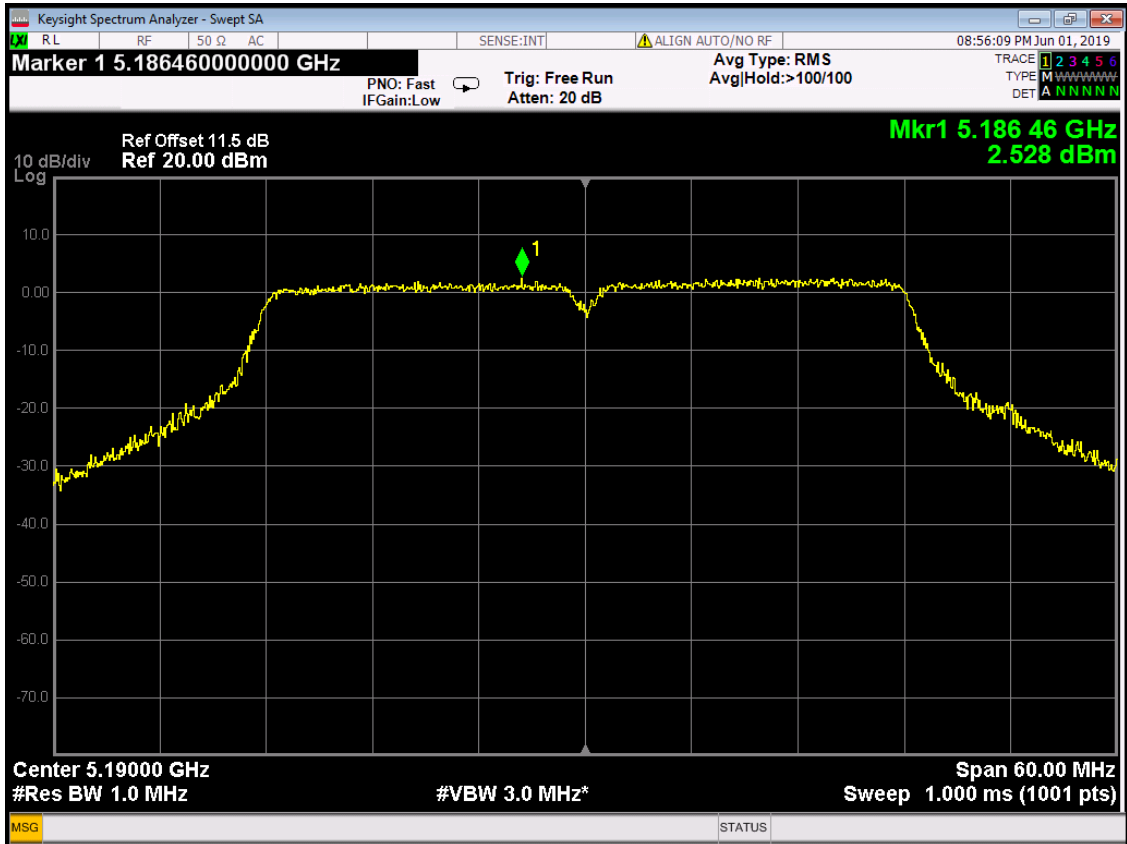

Channel 5230MHz

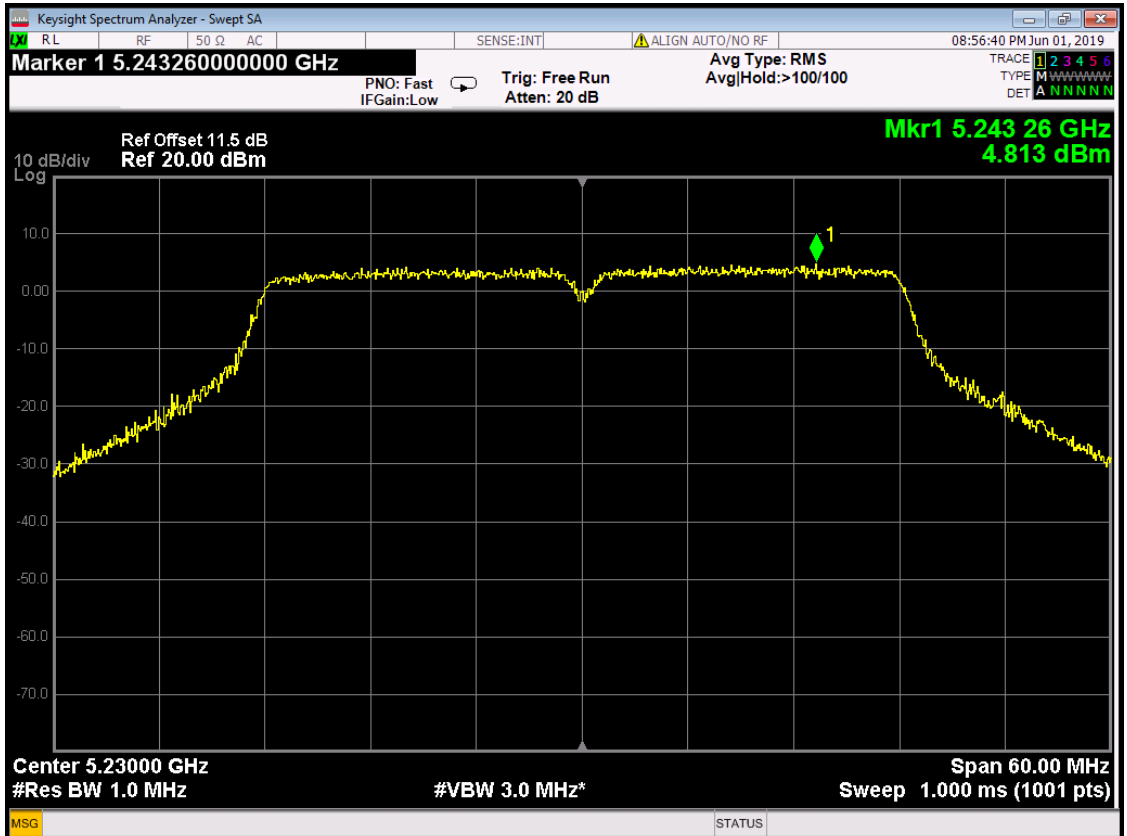

Channel 5755MHz

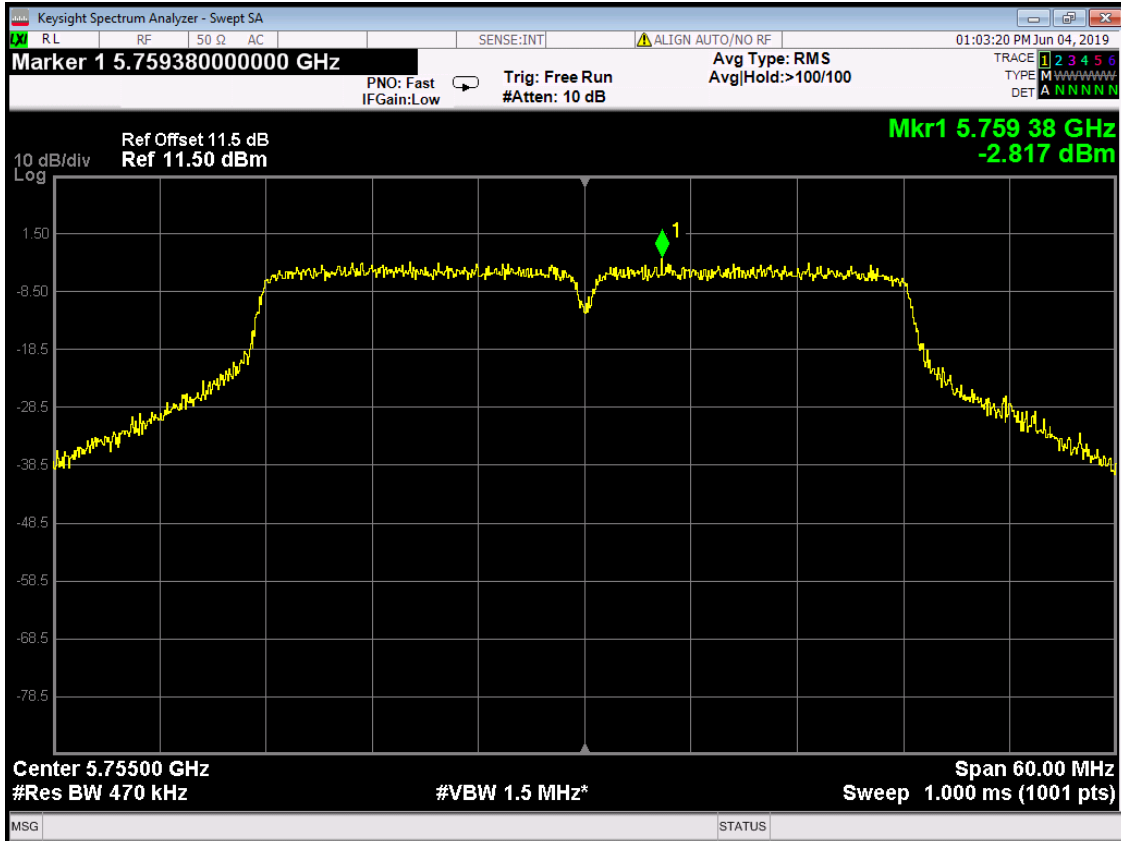

Channel 5795MHz

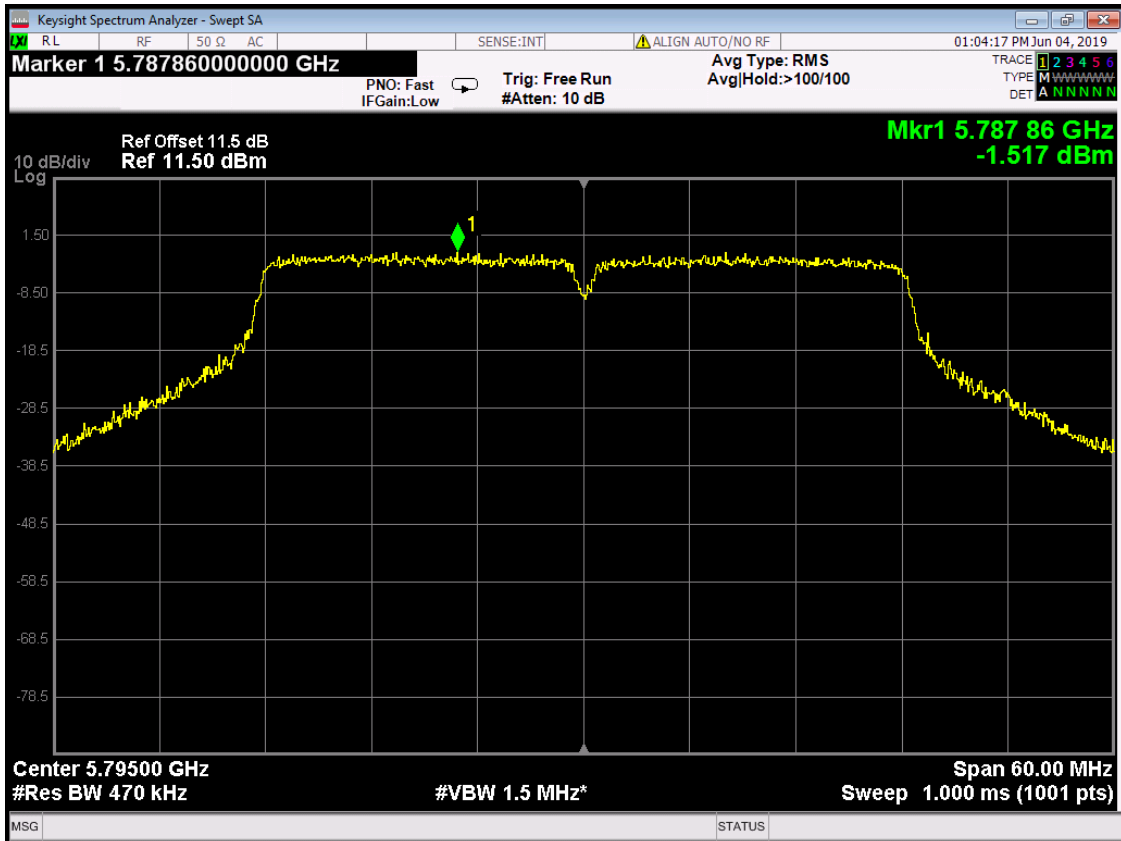

802.11ac 80 mode:
Channel 5210MHz

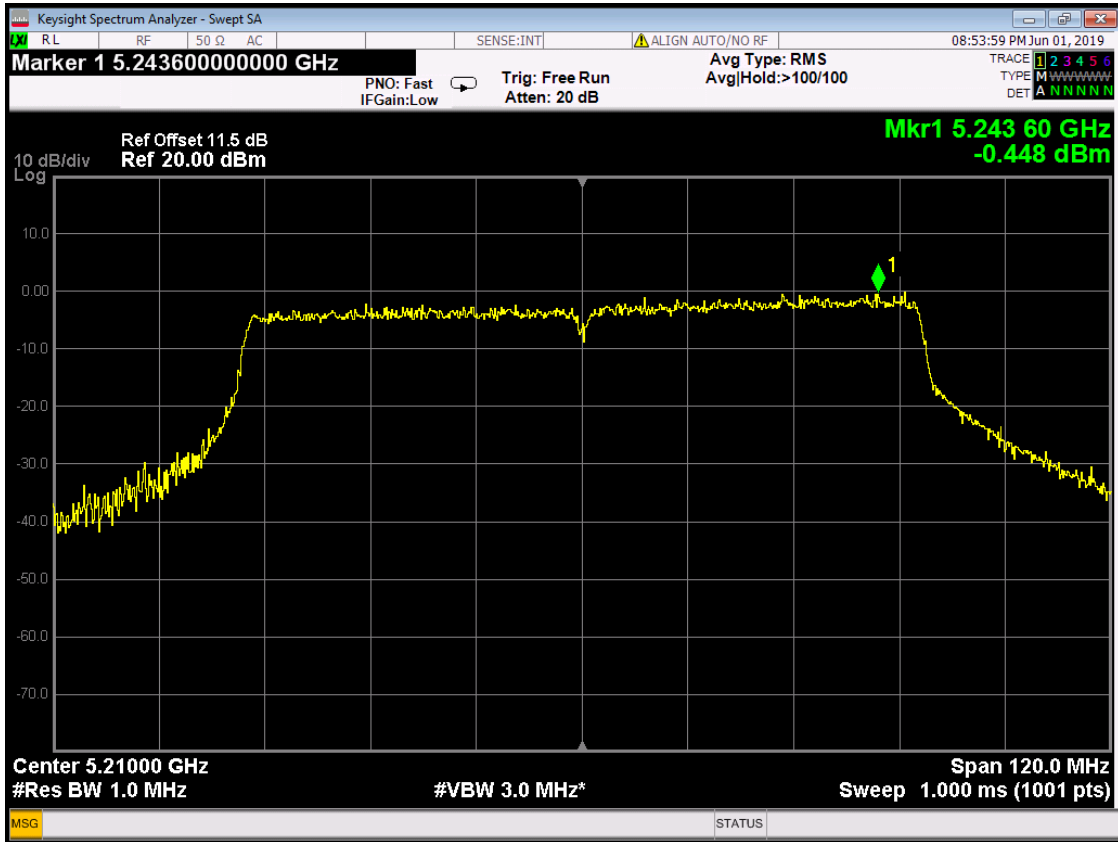

Channel 5775MHz

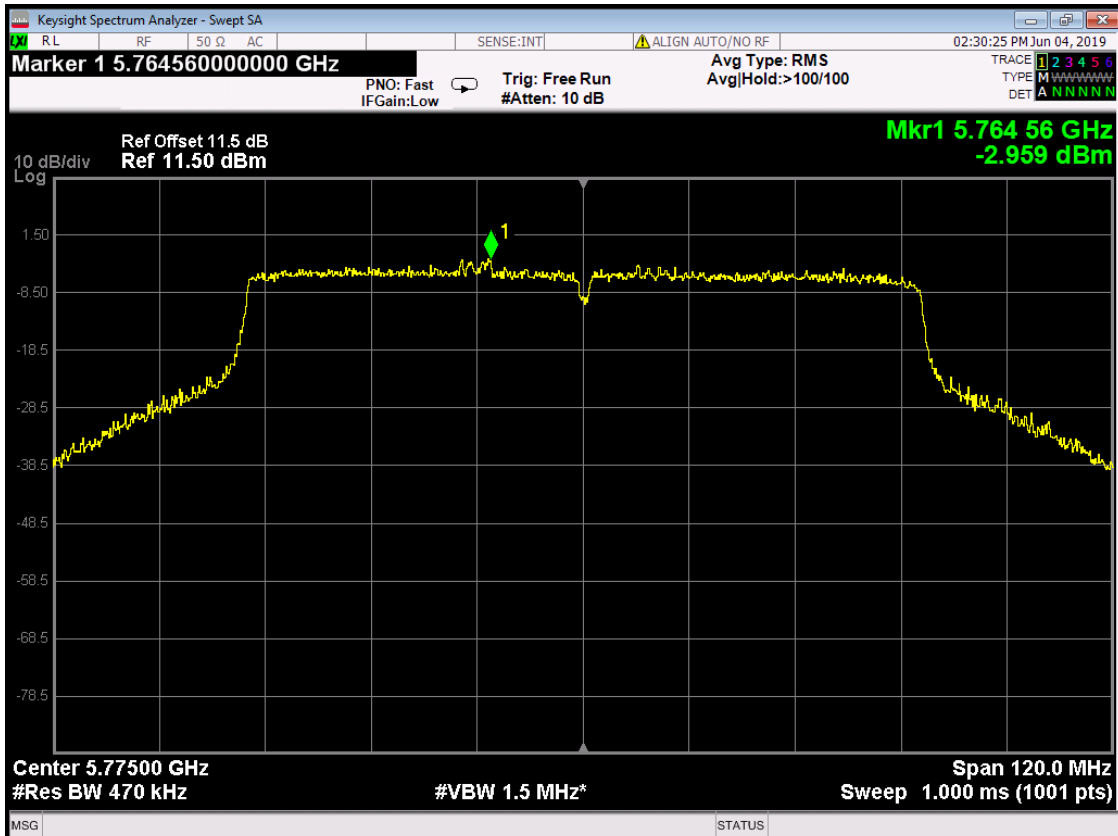

11. FREQUENCY STABILITY

11.1.LIMITS

According to §15.407(g), manufacturers of U-NII devices are responsible for ensuring frequency stability such that an emission is maintained within the band of operation under all conditions of normal operation as specified in the users manual.

11.2.TEST PROCEDURES

The equipment under test was connected to an external AC or DC power supply and input rated voltage. RF output was connected to a frequency counter or spectrum analyzer via feed through attenuators. The EUT was placed inside the temperature chamber. Set the spectrum analyzer RBW low enough to obtain the desired frequency resolution and measure EUT 20°C operating frequency as reference frequency. Turn EUT off and set the chamber temperature to -20°C. After the temperature stabilized for approximately 30 minutes recorded the frequency. Repeat step measure with 10°C increased per stage until the highest temperature of +50°C reached.

11.3.TEST SETUP

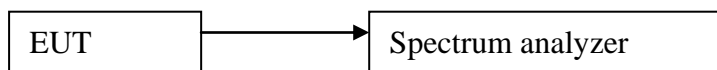

11.4.TEST RESULTS

IEEE 802.11a MHz mode / 5180 ~ 5240MHz (Low)

Environment Temperature (°C)	Volage (V)	Measured Frequency (MHz)	limit Range	Test Result
50	120	5179.968469	5150-5250	PASS
40	120	5179.996479	5150-5250	PASS
30	120	5179.986976	5150-5250	PASS
20	120	5180.019200	5150-5250	PASS
10	120	5179.994844	5150-5250	PASS
0	120	5179.960442	5150-5250	PASS
-10	120	5179.962239	5150-5250	PASS
-20	120	5179.983534	5150-5250	PASS

Environment Temperature (°C)	Volage (V)	Measured Frequency (MHz)	limit Range	Test Result
20	108	5179.958984	5150-5250	PASS
	120	5180.019600	5150-5250	PASS
	132	5179.983216	5150-5250	PASS

IEEE 802.11a MHz mode / 5180 ~ 5240MHz (High)

Environment Temperature (°C)	Volage (V)	Measured Frequency (MHz)	limit Range	Test Result
50	120	5239.993891	5150-5250	PASS
40	120	5239.985230	5150-5250	PASS
30	120	5239.962560	5150-5250	PASS
20	120	5240.016400	5150-5250	PASS
10	120	5239.973259	5150-5250	PASS
0	120	5239.951227	5150-5250	PASS
-10	120	5239.997622	5150-5250	PASS
-20	120	5239.954541	5150-5250	PASS

Environment Temperature (°C)	Volage (V)	Measured Frequency (MHz)	limit Range	Test Result
20	108	5239.996907	5150-5250	PASS
	120	5240.016100	5150-5250	PASS
	132	5239.975949	5150-5250	PASS

IEEE 802.11a MHz mode / 5745 ~ 5825MHz (Low)

Environment Temperature (°C)	Volage (V)	Measured Frequency (MHz)	limit Range	Test Result
50	120	5744.952021	5725-5850	PASS
40	120	5744.998936	5725-5850	PASS
30	120	5744.987362	5725-5850	PASS
20	120	5745.017400	5725-5850	PASS
10	120	5744.959216	5725-5850	PASS
0	120	5744.967350	5725-5850	PASS
-10	120	5744.964223	5725-5850	PASS
-20	120	5744.959266	5725-5850	PASS

Environment Temperature (°C)	Volage (V)	Measured Frequency (MHz)	limit Range	Test Result
20	108	5744.955719	5725-5850	PASS
	120	5745.016900	5725-5850	PASS
	132	5744.952221	5725-5850	PASS

IEEE 802.11a MHz mode / 5745 ~ 5825MHz (High)

Environment Temperature (°C)	Volage (V)	Measured Frequency (MHz)	limit Range	Test Result
50	120	5824.991846	5725-5850	PASS
40	120	5824.951318	5725-5850	PASS
30	120	5824.960362	5725-5850	PASS
20	120	5825.015800	5725-5850	PASS
10	120	5824.951575	5725-5850	PASS
0	120	5824.951800	5725-5850	PASS
-10	120	5824.994892	5725-5850	PASS
-20	120	5824.972144	5725-5850	PASS

Environment Temperature (°C)	Volage (V)	Measured Frequency (MHz)	limit Range	Test Result
20	108	5824.953680	5725-5850	PASS
	120	5825.015770	5725-5850	PASS
	132	5824.951286	5725-5850	PASS

IEEE 802.11n HT 20 MHz mode / 5180 ~ 5240MHz (Low)

Environment Temperature (°C)	Volage (V)	Measured Frequency (MHz)	limit Range	Test Result
50	120	5179.955078	5150-5250	PASS
40	120	5179.988856	5150-5250	PASS
30	120	5179.966959	5150-5250	PASS
20	120	5180.013200	5150-5250	PASS
10	120	5179.997183	5150-5250	PASS
0	120	5179.974461	5150-5250	PASS
-10	120	5179.972099	5150-5250	PASS
-20	120	5179.976513	5150-5250	PASS

Environment Temperature (°C)	Volage (V)	Measured Frequency (MHz)	limit Range	Test Result
20	108	5179.997390	5150-5250	PASS
	120	5180.013400	5150-5250	PASS
	132	5179.998282	5150-5250	PASS

IEEE 802.11n HT 20 MHz mode / 5180 ~ 5240MHz (High)

Environment Temperature (°C)	Volage (V)	Measured Frequency (MHz)	limit Range	Test Result
50	120	5239.988584	5150-5250	PASS
40	120	5239.967701	5150-5250	PASS
30	120	5239.962807	5150-5250	PASS
20	120	5240.013800	5150-5250	PASS
10	120	5239.975395	5150-5250	PASS
0	120	5239.980747	5150-5250	PASS
-10	120	5239.992867	5150-5250	PASS
-20	120	5239.953912	5150-5250	PASS

Environment Temperature (°C)	Volage (V)	Measured Frequency (MHz)	limit Range	Test Result
20	108	5239.949992	5150-5250	PASS
	120	5240.013500	5150-5250	PASS
	132	5239.962942	5150-5250	PASS

IEEE 802.11n HT 20 MHz mode / 5745 ~ 5825MHz (Low)

Environment Temperature (°C)	Volage (V)	Measured Frequency (MHz)	limit Range	Test Result
50	120	5744.995299	5725-5850	PASS
40	120	5744.965211	5725-5850	PASS
30	120	5744.986532	5725-5850	PASS
20	120	5745.015400	5725-5850	PASS
10	120	5744.969194	5725-5850	PASS
0	120	5744.957127	5725-5850	PASS
-10	120	5744.973081	5725-5850	PASS
-20	120	5744.977557	5725-5850	PASS

Environment Temperature (°C)	Volage (V)	Measured Frequency (MHz)	limit Range	Test Result
20	108	5744.962448	5725-5850	PASS
	120	5745.015900	5725-5850	PASS
	132	5744.973397	5725-5850	PASS

IEEE 802.11n HT 20 MHz mode / 5745 ~ 5825MHz (High)

Environment Temperature (°C)	Volage (V)	Measured Frequency (MHz)	limit Range	Test Result
50	120	5824.949927	5725-5850	PASS
40	120	5824.969405	5725-5850	PASS
30	120	5824.982408	5725-5850	PASS
20	120	5825.015400	5725-5850	PASS
10	120	5824.956143	5725-5850	PASS
0	120	5824.985334	5725-5850	PASS
-10	120	5824.998770	5725-5850	PASS
-20	120	5824.972685	5725-5850	PASS

Environment Temperature (°C)	Volage (V)	Measured Frequency (MHz)	limit Range	Test Result
20	108	5824.977909	5725-5850	PASS
	120	5825.016200	5725-5850	PASS
	132	5824.995854	5725-5850	PASS

IEEE 802.11n HT 40 MHz mode / 5190 ~ 5230MHz (Low)

Environment Temperature (°C)	Volage (V)	Measured Frequency (MHz)	limit Range	Test Result
50	120	5189.977100	5150-5250	PASS
40	120	5189.960190	5150-5250	PASS
30	120	5189.999426	5150-5250	PASS
20	120	5190.012900	5150-5250	PASS
10	120	5189.978443	5150-5250	PASS
0	120	5189.987661	5150-5250	PASS
-10	120	5189.995455	5150-5250	PASS
-20	120	5189.954837	5150-5250	PASS

Environment Temperature (°C)	Volage (V)	Measured Frequency (MHz)	limit Range	Test Result
20	108	5189.976695	5150-5250	PASS
	120	5190.012300	5150-5250	PASS
	132	5189.982523	5150-5250	PASS

IEEE 802.11n HT 40 MHz mode / 5190 ~ 5230MHz (High)

Environment Temperature (°C)	Volage (V)	Measured Frequency (MHz)	limit Range	Test Result
50	120	5229.951384	5150-5250	PASS
40	120	5229.994104	5150-5250	PASS
30	120	5229.951136	5150-5250	PASS
20	120	5230.013300	5150-5250	PASS
10	120	5229.979393	5150-5250	PASS
0	120	5229.983413	5150-5250	PASS
-10	120	5229.971993	5150-5250	PASS
-20	120	5229.990471	5150-5250	PASS

Environment Temperature (°C)	Volage (V)	Measured Frequency (MHz)	limit Range	Test Result
20	108	5229.971705	5150-5250	PASS
	120	5230.012700	5150-5250	PASS
	132	5229.970416	5150-5250	PASS

IEEE 802.11n HT 40 MHz mode / 5755 ~ 5795MHz (Low)

Environment Temperature (°C)	Volage (V)	Measured Frequency (MHz)	limit Range	Test Result
50	120	5754.962476	5725-5850	PASS
40	120	5754.988137	5725-5850	PASS
30	120	5754.977947	5725-5850	PASS
20	120	5755.012800	5725-5850	PASS
10	120	5754.962731	5725-5850	PASS
0	120	5754.957833	5725-5850	PASS
-10	120	5754.991542	5725-5850	PASS
-20	120	5754.992786	5725-5850	PASS

Environment Temperature (°C)	Volage (V)	Measured Frequency (MHz)	limit Range	Test Result
20	108	5754.958508	5725-5850	PASS
	120	5755.013600	5725-5850	PASS
	132	5754.954414	5725-5850	PASS

IEEE 802.11n HT 40 MHz mode / 5755 ~ 5795MHz (High)

Environment Temperature (°C)	Volage (V)	Measured Frequency (MHz)	limit Range	Test Result
50	120	5794.988544	5725-5850	PASS
40	120	5794.987537	5725-5850	PASS
30	120	5794.963488	5725-5850	PASS
20	120	5795.013700	5725-5850	PASS
10	120	5794.969287	5725-5850	PASS
0	120	5794.952902	5725-5850	PASS
-10	120	5794.949330	5725-5850	PASS
-20	120	5794.993615	5725-5850	PASS

Environment Temperature (°C)	Volage (V)	Measured Frequency (MHz)	limit Range	Test Result
20	108	5794.958903	5725-5850	PASS
	120	5795.014200	5725-5850	PASS
	132	5794.996576	5725-5850	PASS

IEEE 802.11ac 80 mode / 5210MHz

Environment Temperature (°C)	Volage (V)	Measured Frequency (MHz)	limit Range	Test Result
50	120	5209.954993	5150-5250	PASS
40	120	5209.955785	5150-5250	PASS
30	120	5209.978121	5150-5250	PASS
20	120	5210.013400	5150-5250	PASS
10	120	5209.950743	5150-5250	PASS
0	120	5209.951131	5150-5250	PASS
-10	120	5209.953666	5150-5250	PASS
-20	120	5209.989980	5150-5250	PASS

Environment Temperature (°C)	Volage (V)	Measured Frequency (MHz)	limit Range	Test Result
20	108	5209.973088	5150-5250	PASS
	120	5210.014300	5150-5250	PASS
	132	5209.995753	5150-5250	PASS

IEEE 802.11ac 80 mode / 5775MHz

Environment Temperature (°C)	Volage (V)	Measured Frequency (MHz)	limit Range	Test Result
50	120	5774.987610	5725-5850	PASS
40	120	5774.988527	5725-5850	PASS
30	120	5774.959399	5725-5850	PASS
20	120	5775.014100	5725-5850	PASS
10	120	5774.971001	5725-5850	PASS
0	120	5774.956005	5725-5850	PASS
-10	120	5774.966591	5725-5850	PASS
-20	120	5774.986558	5725-5850	PASS

Environment Temperature (°C)	Volage (V)	Measured Frequency (MHz)	limit Range	Test Result
20	108	5774.979435	5725-5850	PASS
	120	5775.013700	5725-5850	PASS
	132	5774.954492	5725-5850	PASS

12. RESTRICTED BANDS OF OPERATION

12.1. LIMITS

Section 15.407(b)(7) The provisions of §15.205 apply to intentional radiators operating under this section.

15.205(a) Except as shown in paragraph (d) of this section, only spurious emissions are permitted in any of the frequency bands listed below:

MHz	MHz	MHz	GHz
0.090 - 0.110	16.42 - 16.423	399.9 - 410	4.5 - 5.15
¹ 0.495 - 0.505	16.69475 -	608 - 614	5.35 - 5.46
2.1735 - 2.1905	16.69525	960 - 1240	7.25 - 7.75
4.125 - 4.128	16.80425 -	1300 - 1427	8.025 - 8.5
4.17725 - 4.17775	16.80475	1435 - 1626.5	9.0 - 9.2
4.20725 - 4.20775	25.5 - 25.67	1645.5 - 1646.5	9.3 - 9.5
6.215 - 6.218	37.5 - 38.25	1660 - 1710	10.6 - 12.7
6.26775 - 6.26825	73 - 74.6	1718.8 - 1722.2	13.25 - 13.4
6.31175 - 6.31225	74.8 - 75.2	2200 - 2300	14.47 - 14.5
8.291 - 8.294	108 - 121.94	2310 - 2390	15.35 - 16.2
8.362 - 8.366	123 - 138	2483.5 - 2500	17.7 - 21.4
8.37625 - 8.38675	149.9 - 150.05	2655 - 2900	22.01 - 23.12
8.41425 - 8.41475	156.52475 -	3260 - 3267	23.6 - 24.0
12.29 - 12.293	156.52525	3332 - 3339	31.2 - 31.8
12.51975 -	156.7 - 156.9	3345.8 - 3358	36.43 - 36.5
12.52025	162.0125 - 167.17	3600 - 4400	
12.57675 -	167.72 - 173.2		
12.57725	240 - 285		
13.36 - 13.41	322 - 335.4		

12.2. TEST PROCEDURES

- 1) The EUT is placed on a turntable, which is 1.5m above the ground plane.
- 2) The turntable shall be rotated for 360 degrees to determine the position of maximum emission level.
- 3) EUT is set 3m away from the receiving antenna, which is varied from 1m to 4m to find out the highest emission.
- 4) Set the spectrum analyzer in the following setting in order to capture the lower and upper band-edges of the emission:
 - a) PEAK: RBW=1MHz / VBW=1MHz / Sweep=AUTO
 - b) AVERAGE: RBW=1MHz / VBW=1/T / Sweep=AUTO
- 5) Repeat the procedures until all the PEAK and AVERAGE versus POLARIZATION are measured.

12.3. TEST SETUP

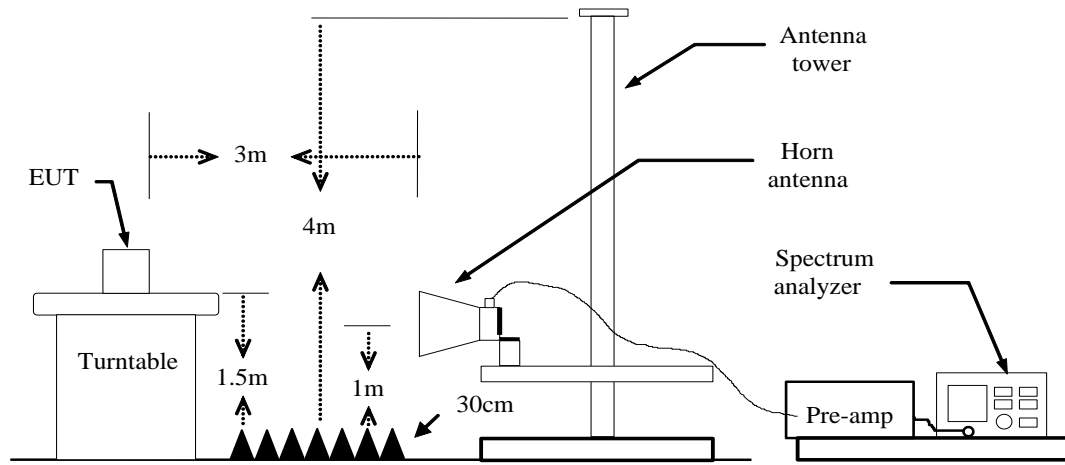

12.4. TEST RESULTS

802.11a mode/5180MHz

Detector mode: Peak

Polarity: Vertical

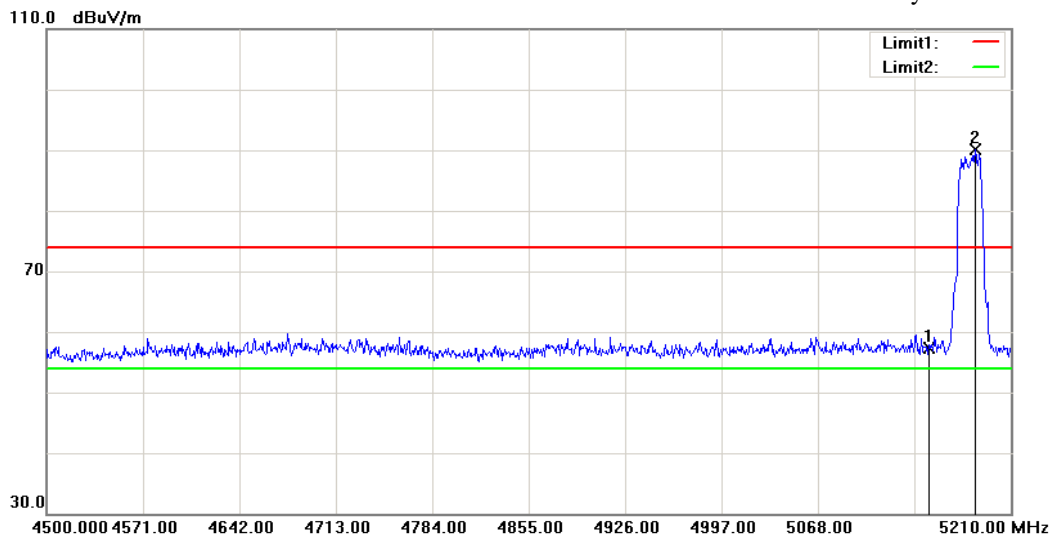

Detector mode: Average

Polarity: Vertical

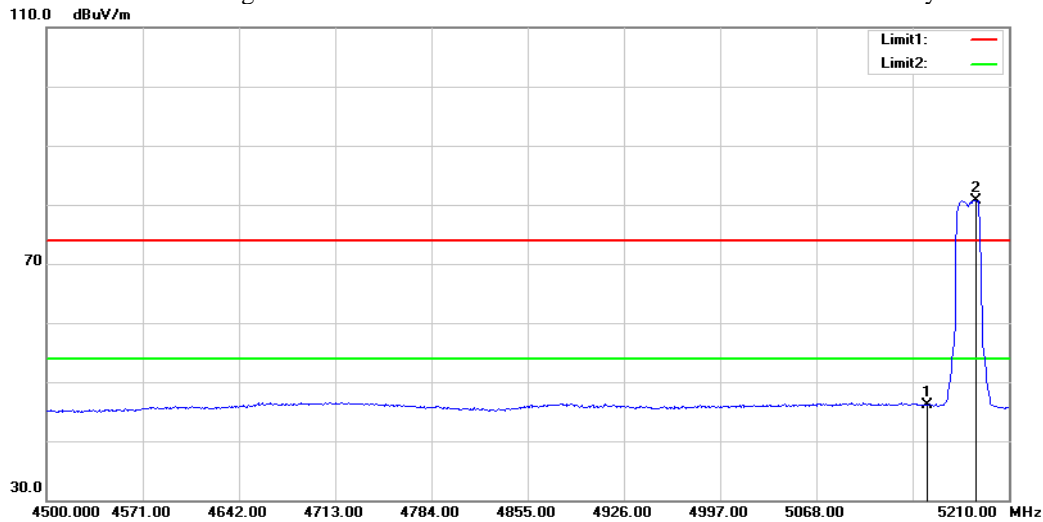

No.	Frequency MHz	Reading dBuV	Factor dB	Result dBuV/m	Limit dBuV/m	Margin dB	Remark	Pole
1	5150.000	54.64	2.66	57.30	74.00	-16.70	Peak	Vertical
2	5183.730	87.39	2.75	---	74.00	---	Peak	Vertical
1	5150.000	43.51	2.66	46.17	54.00	-7.83	Average	Vertical
2	5185.860	77.98	2.76	---	54.00	---	Average	Vertical

Detector mode: Peak

Polarity: Horizontal

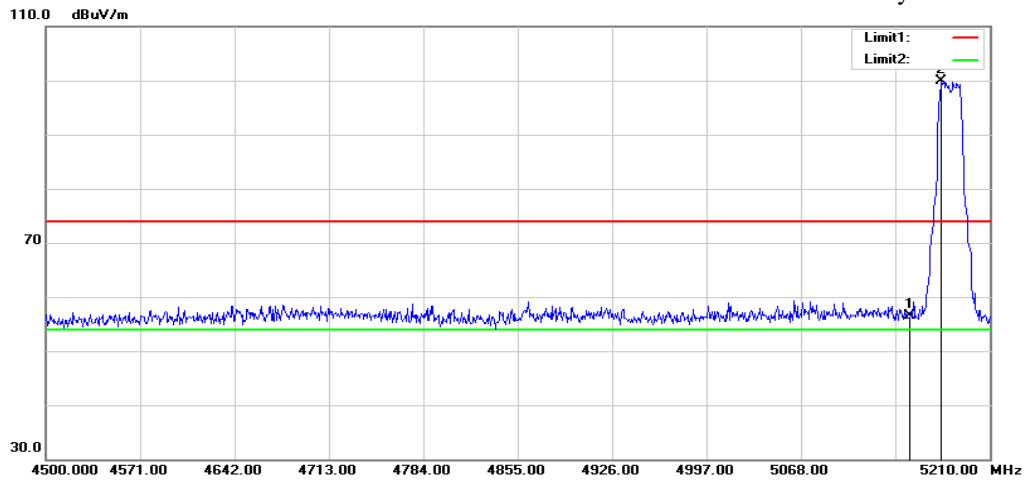

Detector mode: Average

Polarity: Horizontal

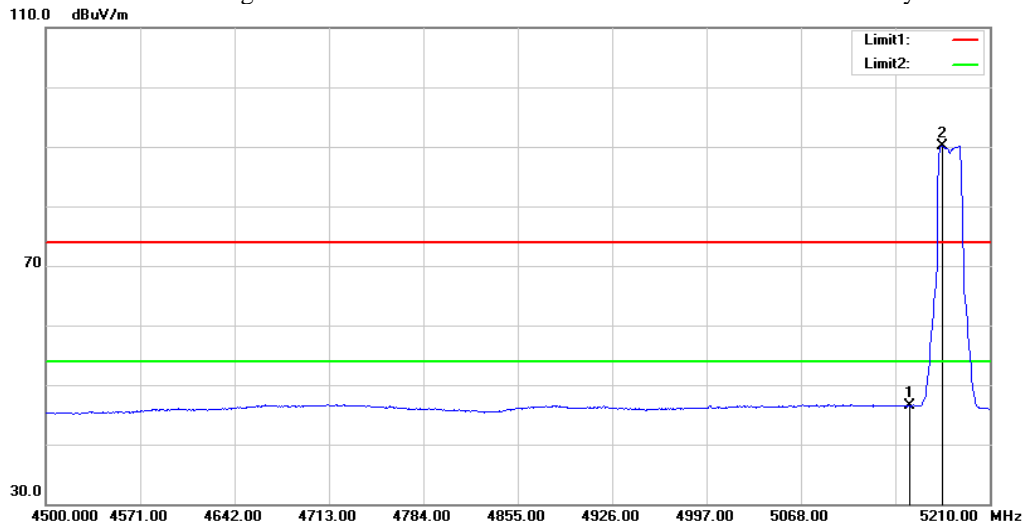

No.	Frequency MHz	Reading dBuV	Factor dB	Result dBuV/m	Limit dBuV/m	Margin dB	Remark	Pole
1	5150.000	53.83	2.66	56.49	74.00	-17.51	Peak	Horizontal
2	5173.790	97.20	2.73	---	74.00	---	Peak	Horizontal
1	5150.000	43.84	2.66	46.50	54.00	-7.50	Average	Horizontal
2	5174.500	87.39	2.73	---	54.00	---	Average	Horizontal

802.11n HT20 mode/5180MHz

Detector mode: Peak

Polarity: Vertical

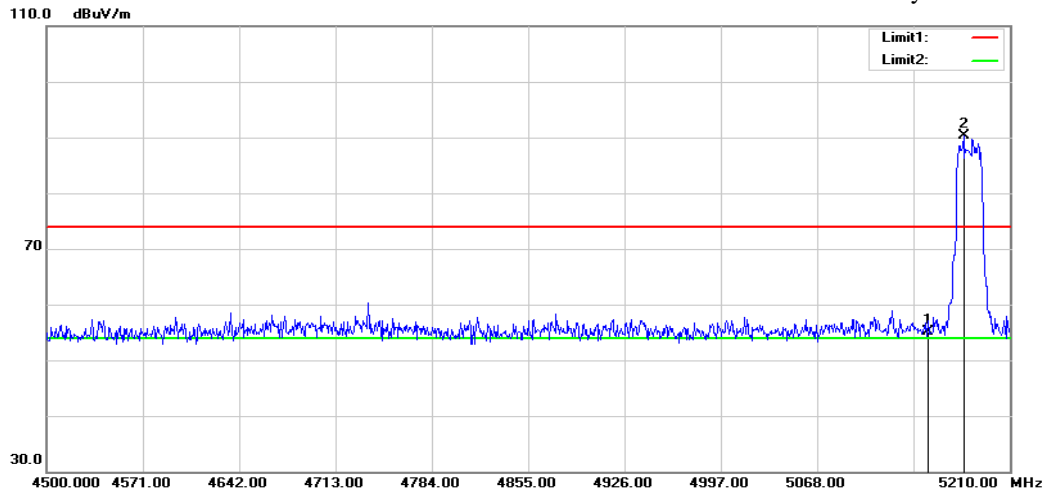

Detector mode: Average

Polarity: Vertical

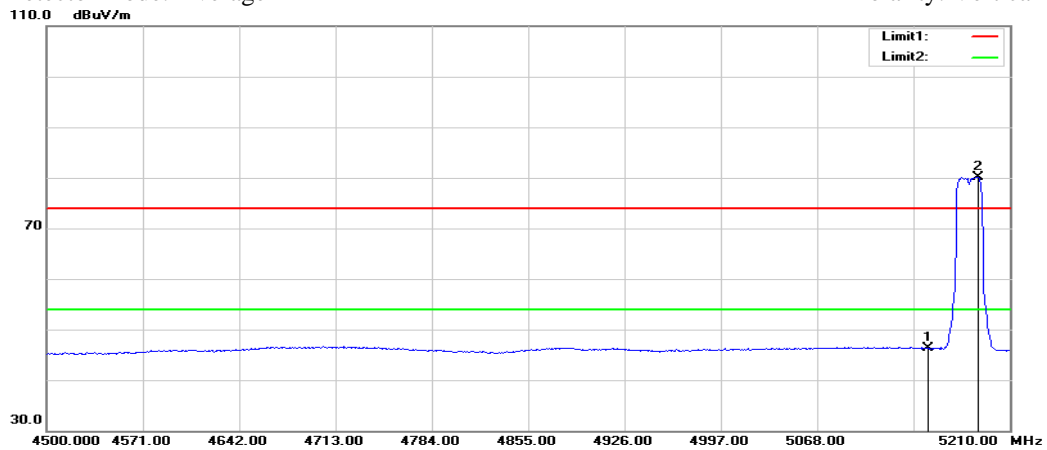

No.	Frequency MHz	Reading dBuV	Factor dB	Result dBuV/m	Limit dBuV/m	Margin dB	Remark	Pole
1	5150.000	52.35	2.66	55.01	74.00	-18.99	Peak	Vertical
2	5175.920	87.65	2.74	---	74.00	---	Peak	Vertical
1	5150.000	43.65	2.66	46.31	54.00	-7.69	Average	Vertical
2	5186.570	77.36	2.76	---	54.00	---	Average	Vertical

Channel Low

Detector mode: Peak

Polarity: Horizontal

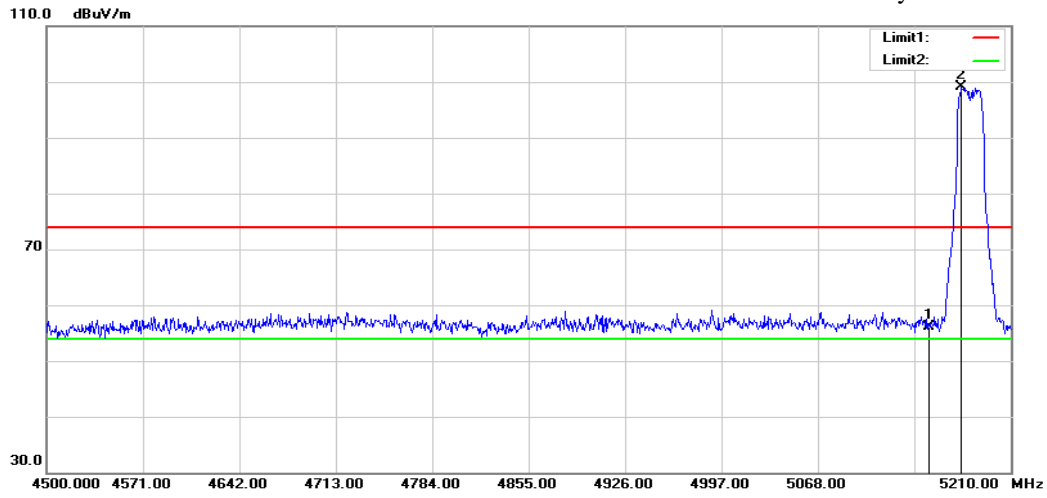

Detector mode: Average

Polarity: Horizontal

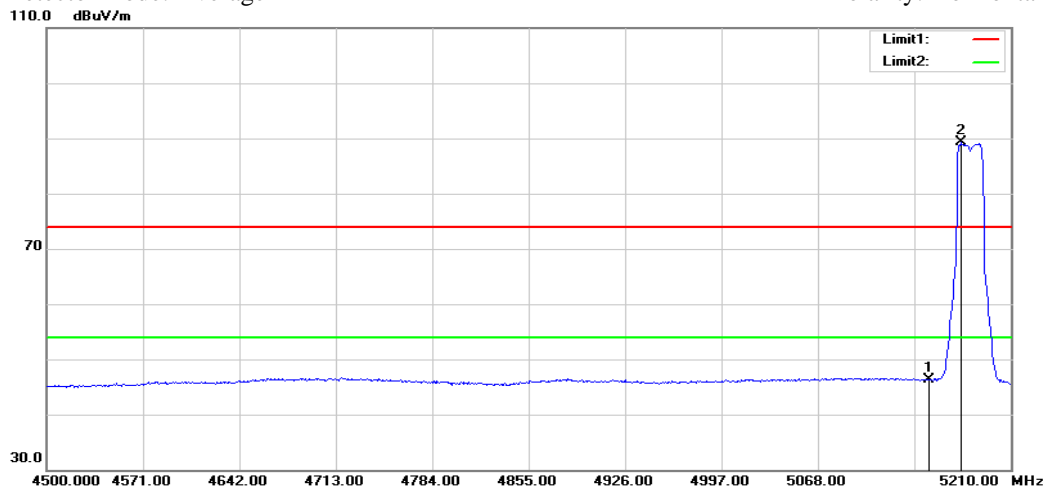

No.	Frequency MHz	Reading dBuV	Factor dB	Result dBuV/m	Limit dBuV/m	Margin dB	Remark	Pole
1	5150.000	53.52	2.66	56.18	74.00	-17.82	Peak	Horizontal
2	5173.790	96.28	2.73	---	74.00	---	Peak	Horizontal
1	5150.000	43.62	2.66	46.28	54.00	-7.72	Average	Horizontal
2	5173.080	86.55	2.73	---	54.00	---	Average	Horizontal

802.11n HT40 mode/5190MHz

Detector mode: Peak

Polarity: Vertical

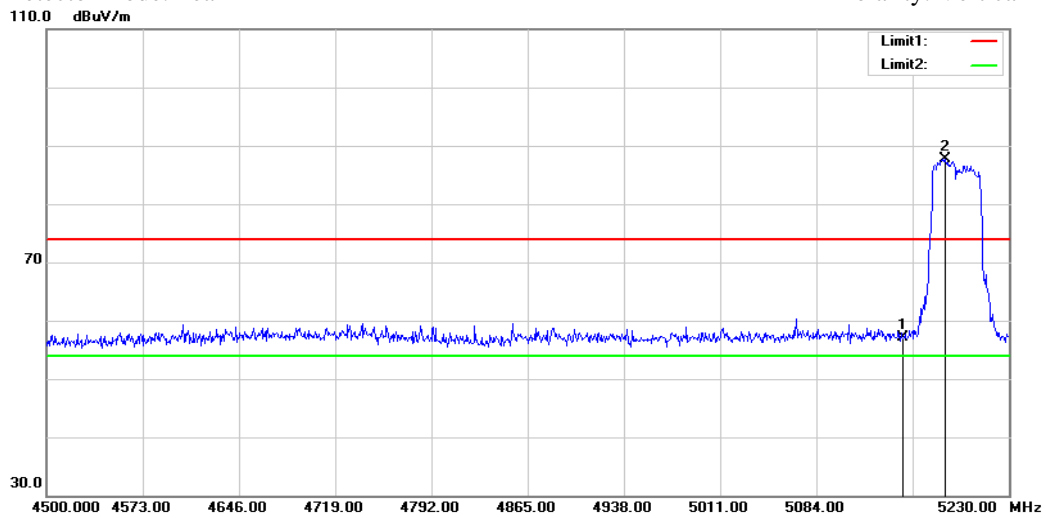

Detector mode: Average

Polarity: Vertical

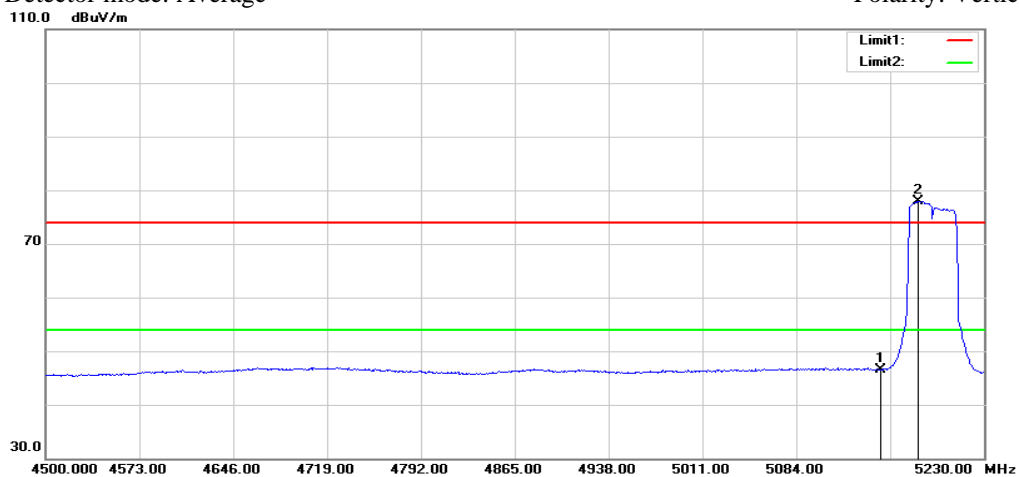

No.	Frequency MHz	Reading dBuV	Factor dB	Result dBuV/m	Limit dBuV/m	Margin dB	Remark	Pole
1	5150.000	54.52	2.66	57.18	74.00	-16.82	Peak	Vertical
2	5181.820	84.91	2.75	---	74.00	---	Peak	Vertical
1	5150.000	43.93	2.66	46.59	54.00	-7.41	Average	Vertical
2	5178.900	75.22	2.74	---	54.00	---	Average	Vertical

Detector mode: Peak

Polarity: Horizontal

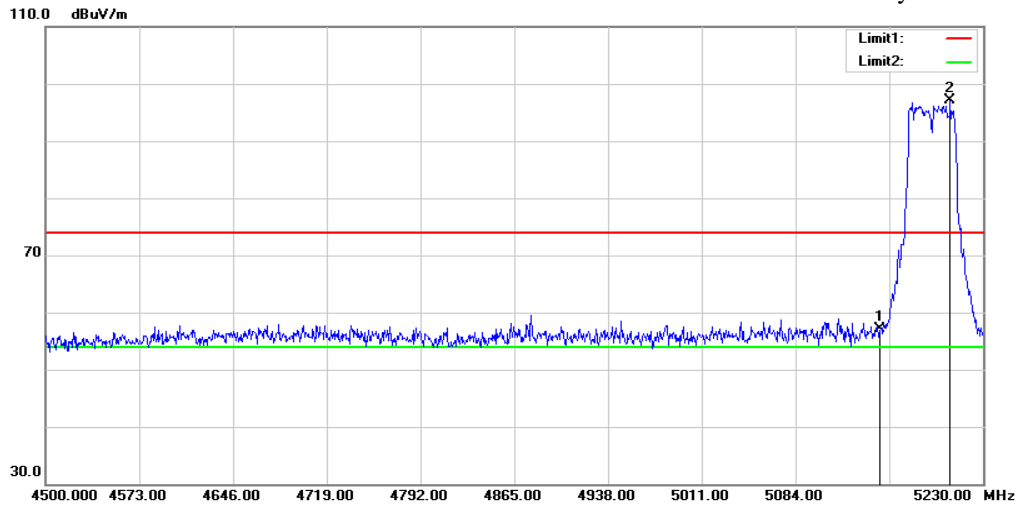

Detector mode: Average

Polarity: Horizontal

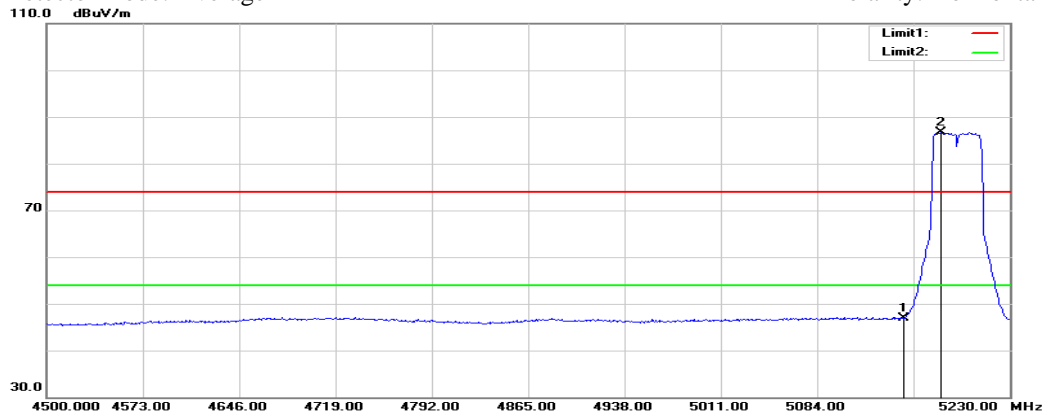

No.	Frequency MHz	Reading dBuV	Factor dB	Result dBuV/m	Limit dBuV/m	Margin dB	Remark	Pole
1	5150.000	54.47	2.66	57.13	74.00	-16.87	Peak	Horizontal
2	5204.450	94.30	2.81	---	74.00	---	Peak	Horizontal
1	5150.000	44.32	2.66	46.98	54.00	-7.02	Average	Horizontal
2	5177.440	84.06	2.74	---	54.00	---	Average	Horizontal

802.11ac 80 mode/5210MHz

Detector mode: Peak

Polarity: Vertical

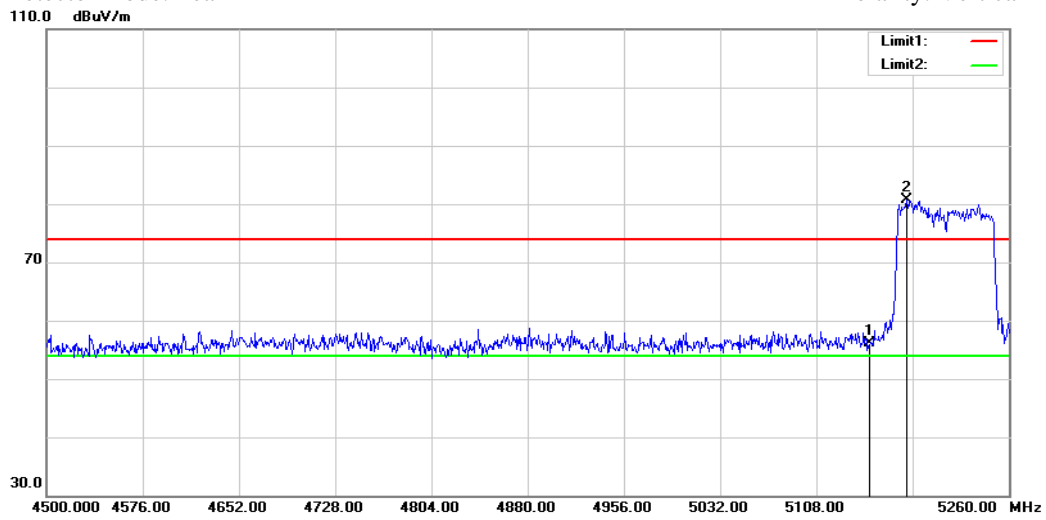

Detector mode: Average

Polarity: Vertical

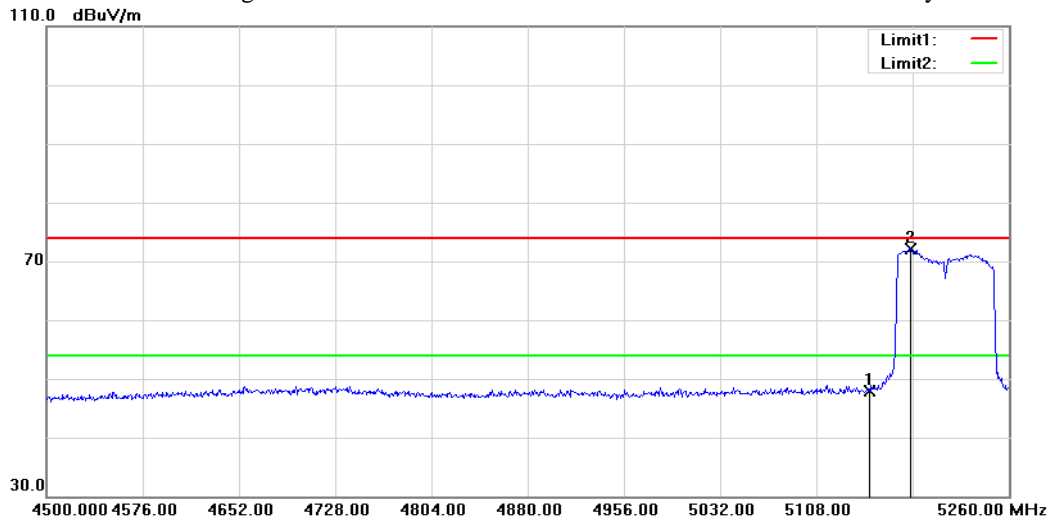

No.	Frequency MHz	Reading dBuV	Factor dB	Result dBuV/m	Limit dBuV/m	Margin dB	Remark	Pole
1	5150.000	53.35	2.66	56.01	74.00	-17.99	Peak	Vertical
2	5179.440	77.93	2.74	---	74.00	---	Peak	Vertical
1	5150.000	45.18	2.66	47.84	54.00	-6.16	Average	Vertical
2	5182.480	69.45	2.75	---	54.00	---	Average	Vertical

Detector mode: Peak Polarity: Horizontal

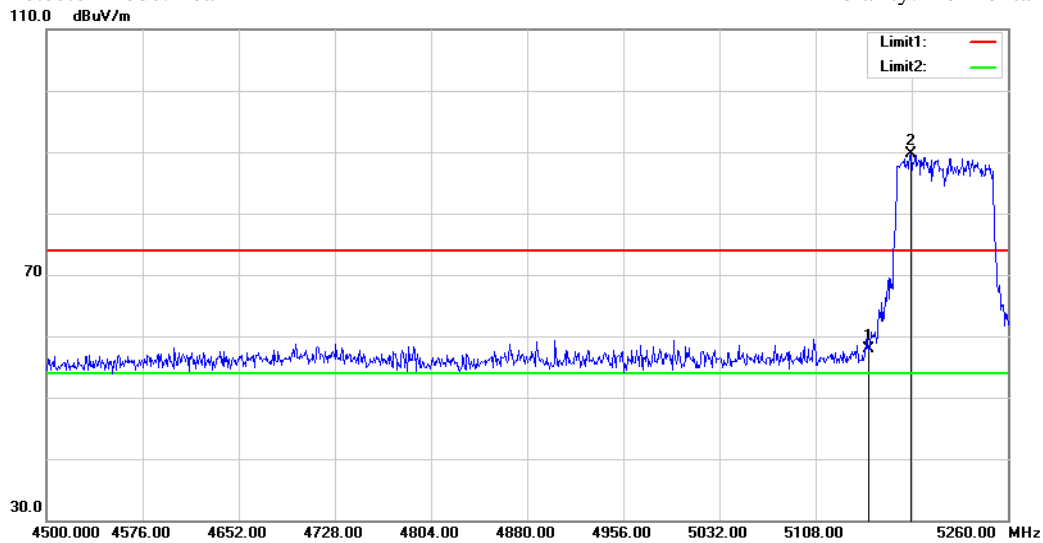

Detector mode: Average Polarity: Horizontal

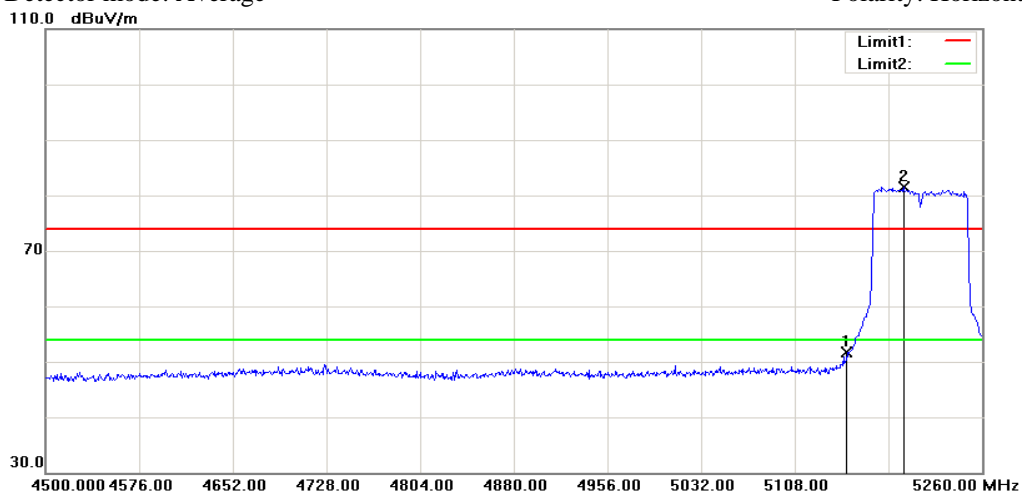

No.	Frequency MHz	Reading dBuV	Factor dB	Result dBuV/m	Limit dBuV/m	Margin dB	Remark	Pole
1	5150.000	55.22	2.66	57.88	74.00	-16.12	Peak	Horizontal
2	5183.240	86.99	2.75	---	74.00	---	Peak	Horizontal
1	5150.000	49.04	2.66	51.70	54.00	-2.30	Average	Horizontal
2	5196.160	78.76	2.79	---	54.00	---	Average	Horizontal

Remark: Max field strength in 3m distance. No any other emission which falls in restricted bands can be detected and be reported.

APPENDIX A: PHOTOGRAPH OF THE TEST ARRANGEMENT

CE

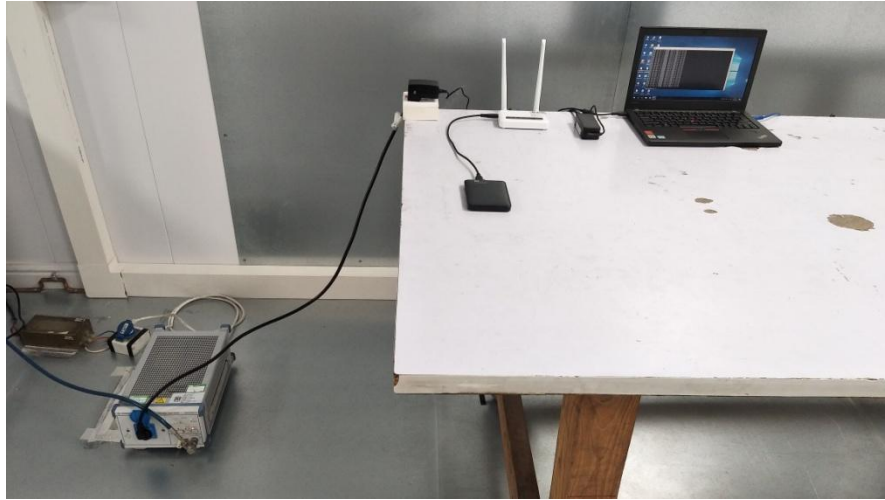

RSE (Below 1GHz)



RSE (Above 1GHz)



-----This is the last page of the report. -----