



FCC RADIO TEST REPORT

FCC ID: 2AFIA-MINIBOX

Product	Android Sticker
Trade Name	ugoos
Model Number	minibox, MK809V, am1, am2, am3, MK809IV
Report No.	POCE15072234NRR



Prepared for

Ugoos industrial co., ltd
Room2502 Wen'an Center, Wenjin Square, Wenjin North Road, Luohu District, Shenzhen, Guangdong Province, China

Prepared by

Shenzhen POCE Technology Co.,Ltd.
Room 502, Bldg. 1, Xinghua Garden, Baoan Road Xixiang, Baoan District, Shenzhen, China

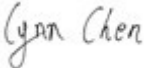
TEST RESULT CERTIFICATION	
Applicant's name	Ugoos industrial co., ltd
Address.....	Room2502 Wen'an Center, Wenjin Square, Wenjin North Road, Luohu District, Shenzhen, Guangdong Province, China
Manufacture's Name	Ugoos industrial co., ltd
Address.....	Room2502 Wen'an Center, Wenjin Square, Wenjin North Road, Luohu District, Shenzhen, Guangdong Province, China
Product description	
Product name.....	Android Sticker
Model and/or type reference.....	minibox, MK809V, am1, am2, am3, MK809IV
Ratings	AC 120V/60Hz
Standards	FCC Part15.247
Test procedure.....	ANSI.C63.10-2010 KDB Publication No. 558074 D01 v03r02 Guidance on Measurements for Digital Transmission Systems
<p>This device described above has been tested by POCE, and the test results show that the equipment under test (EUT) is in compliance with the FCC requirements. And it is applicable only to the tested sample identified in the report.</p> <p>This report shall not be reproduced except in full, without the written approval of POCE, this document may be altered or revised by POCE, personal only, and shall be noted in the revision of the document.</p>	
Date of Test	:
Date (s) of performance of tests.....	Nov. 30, 2015 ~ Dec. 05, 2015
Date of Issue.....	Dec. 05, 2015
Test Result.....	Pass

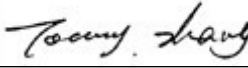
Testing Engineer	:	
		(Lynn Chen)
Technical Manager	:	
		(Carlen Liu)
Authorized Signatory	:	
		(Tommy zhang)

The test report merely corresponds to the test sample.
It is not permitted to copy extracts of these test result without the written permission of the test laboratory.

Contents

1.	<u>TEST STANDARDS</u>	4
2.	<u>SUMMARY</u>	5
2.1.	General Remarks	5
2.2.	Equipment Under Test	5
2.3.	Short description of the Equipment under Test (EUT)	5
2.4.	EUT operation mode	6
2.5.	EUT configuration	6
2.6.	NOTE	6
2.7.	Related Submittal(s) / Grant (s)	6
2.8.	Modifications	6
3.	<u>TEST ENVIRONMENT</u>	7
3.1.	Address of the test laboratory	7
3.2.	Test Facility	7
3.3.	Environmental conditions	7
3.4.	Configuration of Tested System	7
3.5.	Duty Cycle	8
3.6.	Statement of the measurement uncertainty	8
3.7.	Equipments Used during the Test	9
3.8.	Summary of Test Result	10
4.	<u>TEST CONDITIONS AND RESULTS</u>	11
4.1.	Conducted Emissions Test	11
4.2.	Radiated Emission and Bandedge Test	14
4.3.	6dB Bandwidth Measurement	21
4.4.	Maximum Peak Output Power	27
4.5.	Power Spectral Density Measurement	29
4.6.	Spurious RF Conducted Emission and bandedge	36
4.8.	Antenna Requirement	51
5.	<u>TEST SETUP PHOTOS OF THE EUT</u>	52
6.	<u>External and Internal Photos of the EUT</u>	53

1. TEST STANDARDS

The tests were performed according to following standards:

[FCC Part 15.247](#): Frequency Hopping, Direct Spread Spectrum and Hybrid Systems that are in operation within the bands of 902-928 MHz, 2400-2483.5 MHz, and 5725-5850 MHz.

[ANSI C63.10-2013](#): American National Standard for Testing Unlicensed Wireless Devices.

[KDB Publication No. 558074 D01 v03r02 Guidance on Measurements for Digital Transmission Systems](#)

2 . SUMMARY

1.1. General Remarks

Date of receipt of test sample	:	Nov. 30, 2015
Testing commenced on	:	Nov. 30, 2015
Dec. 05, 2015		
:		
Testing concluded on		

1.2. Equipment Under Test

Power supply system utilised

Power supply voltage	:	<input checked="" type="radio"/> 120V / 60 Hz	<input type="radio"/> 115V / 60Hz
		<input type="radio"/> 12 V DC	<input type="radio"/> 24 V DC
		<input type="radio"/> Other (specified in blank below)	

Description of the test mode

IEEE 802.11b/g/n(HT20): Thirteen channels are provided to the EUT, but only eleven channels used for USA.

Channel	Frequency(MHz)	Channel	Frequency(MHz)
1	2412	8	2447
2	2417	9	2452
3	2422	10	2457
4	2427	11	2462
5	2432		
6	2437		
7	2442		

1.3. Short description of the Equipment under Test (EUT)

Android Sticker, support 802.11b/g/n.

For more details, refer to the user's manual of the EUT.

Serial number: Prototype

1.4. EUT operation mode

Test Mode:

1. The EUT has been tested under normal operating condition.
2. Test program used to control the EUT for staying in continuous transmitting and receiving mode is programmed. Channel low (2412MHz), mid (2437MHz) and high (2462MHz) for 802.11b/g/n(HT20) with highest data rate are chosen for full testing.
3. Test Mode:

Test Mode(TM)	Description	Remark
1	Transmitting	802.11 b 2412MHz, 2437MHz, 2462MHz
2	Transmitting	802.11 g 2412MHz, 2437MHz, 2462MHz
3	Transmitting	802.11 n HT20 2412MHz, 2437MHz, 2462MHz

1.5. EUT configuration

The following peripheral devices and interface cables were connected during the measurement:

- supplied by the manufacturer
- supplied by the lab

AC adapter

Manufacturer: ugoos Industrial co.,ltd
Model: Ug1

1.6. NOTE

1. The EUT is a Android Sticker ,The functions of the EUT listed as below:

	Test Standards	Reference Report
WLAN 802.11b/g, 802.11n	FCC Part 15 Subpart C (Section15.247) FCC Per 47 CFR 2.1091(b)	POCE15072234NRR POCE15072234NRM

2. The frequency bands used in this EUT are listed as follows:

Frequency Band(MHz)	2400-2483.5	5150-5350	5470-5725	5725-5850
802.11b	✓	☐	☐	☐
802.11g	✓	☐	☐	☐
802.11n(20MHz)	✓	☐	☐	☐

3. The EUT incorporates a SISO function, Physically,the EUT provides two completed transmitter and two completed receivers.

Modulation Mode	TX Function
802.11b	1TX
802.11g	1TX
802.11n (20MHz)	1TX

1.7. Related Submittal(s) / Grant (s)

This submittal(s) (test report) is intended for FCCID: 2AFIA-MINIBOX filing to comply with of the FCC part15.247 Rules.

1.8. Modifications

No modifications were implemented to meet testing criteria.

3. TEST ENVIRONMENT

1.9. Address of the test laboratory

Shenzhen POCE Technology Co.,Ltd.

Room 502, Bldg. 1, Xinghua Garden, Baoan Road Xixiang, Baoan District, Shenzhen, China

There is one 3m semi-anechoic chamber and two line conducted labs for final test. The Test Sites meet the requirements in documents ANSI C63.10 and CISPR 22/EN 55022 requirement.

1.10. Test Facility

The test facility is recognized, certified, or accredited by the following organizations:

FCC-Registration No.: 222278

Shenzhen POCE Technology Co.,Ltd. EMC Laboratory has been registered and fully described in a report filed with the (FCC) Federal Communications Commission. The acceptance letter from the FCC is maintained in our files. Registration 222278.

1.11. Environmental conditions

During the measurement the environmental conditions were within the listed ranges:

Temperature: 15-35 ° C

Humidity: 30-60 %

Atmospheric pressure: 950-1050mbar

1.12. Configuration of Tested System

Fig. 2-1 Configuration of Tested System

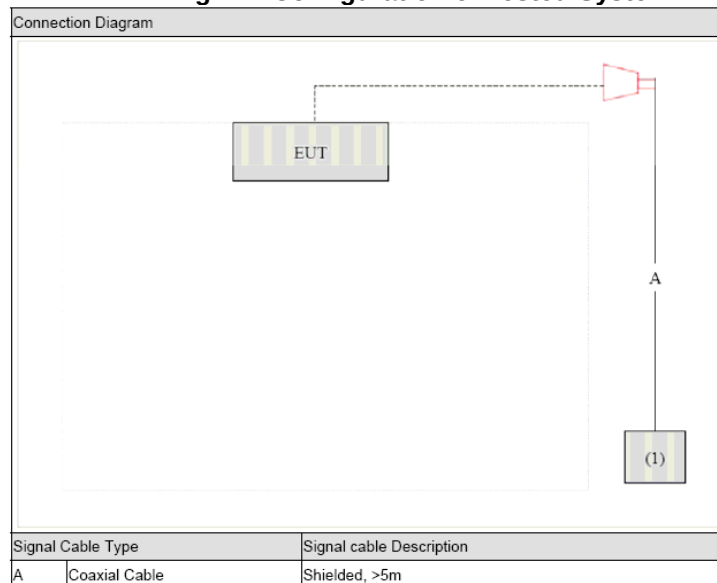

1.13. Duty Cycle

Operated Mode for Worst Duty Cycle		
<input type="checkbox"/>	Operated normally mode for worst duty cycle	
<input checked="" type="checkbox"/>	Operated test mode for worst duty cycle	
Mode	Duty Cycle (%)	Duty Factor (dB)
11b	100	0
11g	100	0
11n HT20	100	0

1.14. Statement of the measurement uncertainty

The reported uncertainty of measurement $y \pm U$ where expanded uncertainty U is based on a standard uncertainty multiplied by a coverage factor of $k=2$ providing a level of confidence of approximately 95 %

No.	Item	Uncertainty
1	Conducted Emission Test	$\pm 1.38\text{dB}$
2	RF power, conducted	$\pm 0.16\text{dB}$
3	Spurious emissions, conducted	$\pm 0.21\text{dB}$
4	All emissions, radiated (<1G)	$\pm 4.68\text{dB}$
5	All emissions, radiated (>1G)	$\pm 4.89\text{dB}$
6	Temperature	$\pm 0.5^\circ\text{C}$
7	Humidity	$\pm 2\%$

1.15. Equipments Used during the Test

Item	Kind of Equipment	Manufacturer	Type No.	Serial No.	Calibration Date
1	Spectrum Analyzer	Agilent	E4407B	160400005	Jul. 12. 2015
2	Test Receiver	R&S	ESPI	101318	Jul. 12. 2015
3	Bilog Antenna	TESEQ	CBL6111D	31216	Oct. 16. 2015
4	50Ω Coaxial Switch	Anritsu	MP59B	6200264416	Jul. 06. 2015
5	Spectrum Analyzer	ADVANTEST	R3132	150900201	Jul. 06. 2015
6	Horn Antenna	EM	EM-AH-10180	2011071402	Oct. 16. 2015
7	Horn Ant	Schwarzbeck	BBHA 9170	9170-181	Oct. 16. 2015
8	Amplifier	EM EM-30180	060538	Jul. 12. 2015	
9	Loop Antenna	ARA	PLA-1030/B	1029	Oct. 16. 2015
10	Power Meter	R&S	NRVS	100696	Jul. 06. 2015
11	Test Receiver	R&S	ESCI	101160	Jul. 12. 2015
12	LISN	R&S	ENV216	101313	Jul. 06. 2015
13	LISN	EMCO	3816/2	00042990	Jul. 06. 2015
14	50Ω Coaxial Switch	Anritsu	MP59B	6200264417	Jul. 06. 2015
15	Passive Voltage Probe	R&S	ESH2-Z3	100196	Jul. 06. 2015
16	Absorbing clamp	R&S	MOS-21	100423	Jul. 06. 2015
17	The temporary antenna connector	MMCX□SMA	1547	23657478	Jul. 06. 2015
18	RF Cable(1-25G Hz)	HUBER+SUHNER	RG214	N/A	Jul. 06. 2015
19	RF Cable(0-1GHz)	HUBER+SUHNER	RG174	N/A	Jul. 06. 2015

Note:1.The temporary antenna connector is soldered on the PCB board in order to perform conducted tests and this temporary antenna connector is listed in the equipment list.

2.The Cal. Due is 1 year.

1.16. Summary of Test Result

FCC PART 15		
FCC Part 15.207	AC Power Conducted Emission	PASS
FCC Part 15.247(a)(2)	6dB Bandwidth	PASS
FCC Part 15.247(d)	Spurious RF Conducted Emission	PASS
FCC Part 15.247(b)	Maximum Peak Output Power	PASS
FCC Part 15.247(e)	Power Spectral Density	PASS
FCC Part 15.109/ 15.205/ 15.209	Radiated Emissions	PASS
FCC Part 15.247(d)	Band Edge Compliance of RF Emission	PASS
FCC Part 15.203/15.247 (b)	Antenna Requirement	PASS

Remark: The measurement uncertainty is not included in the test result.

Preliminary tests were performed in different data rate to find the worst radiated emission. The data rate shown in the table below is the worst-case rate with respect to the specific test item. Investigation has been done on all the possible configurations for searching the worst cases. The following table is a list of the test modes shown in this test report.

Test Items	Mode	Data Rate	Channel
AC Power Conducted Emission	Normal Link	11 Mbps	1
Maximum Peak Conducted Output Power Power Spectral Density 6dB Bandwidth Spurious RF conducted emission	11b/DSSS	11 Mbps	1/6/11
	11g/OFDM	54 Mbps	1/6/11
	11n(20MHz)/OFDM	65Mbps	1/6/11
Radiated Emission 30MHz~1GHz	11b/DSSS	11 Mbps	1/6/11
	11g/OFDM	54 Mbps	1/6/11
	11n(20MHz)/OFDM	65Mbps	1/6/11
Radiated Emission 1GHz~10th Harmonic	11b/DSSS	11 Mbps	1/6/11
	11g/OFDM	54 Mbps	1/6/11
	11n(20MHz)/OFDM	65Mbps	1/6/11
Band Edge Compliance of RF Emission	11b/DSSS	11 Mbps	1/11
	11g/OFDM	54 Mbps	1/11
	11n(20MHz)/OFDM	65Mbps	1/11

Note1: According exploratory test, EUT will have maximum output power in those data rate, so those data rate were used for all test.

4. TEST CONDITIONS AND RESULTS

1.17. Conducted Emissions Test

TEST CONFIGURATION

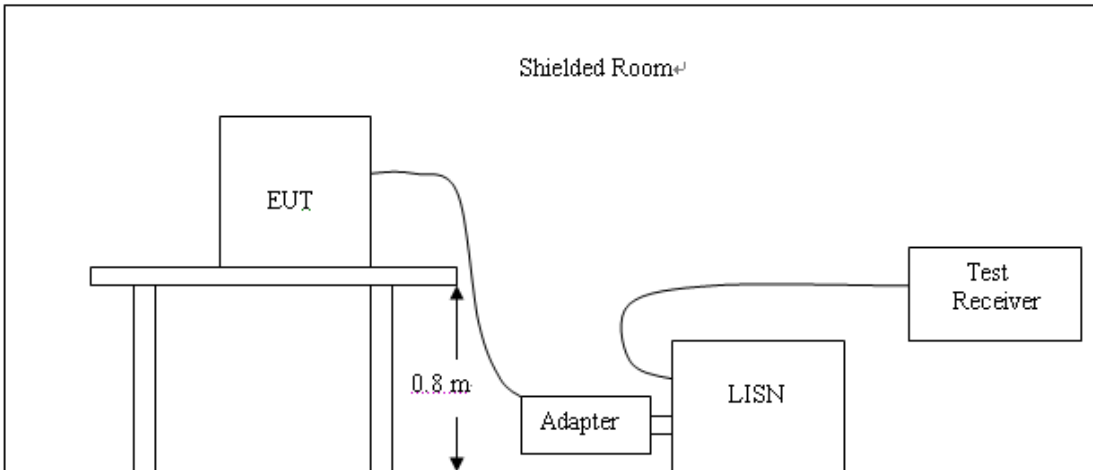

TEST PROCEDURE

For unintentional device, according to § 15.107(a) Line Conducted Emission Limits is as following□

Frequency (MHz)	Maximum RF Line Voltage (dBµV)			
	CLASS A		CLASS B	
	Q.P.	Ave.	Q.P.	Ave.
6666-56*56-46*				
0.50 - 5.0079	73	60	56	46
0.15 - 0.50				
5.00 - 30.0	73	60	60	50

* Decreasing linearly with the logarithm of the frequency

For intentional device, according to §15.207(a) Line Conducted Emission Limit is same as above table.

1. Please follow the guidelines in ANSI C63.10-2013.
2. The EUT was placed 0.4 meter from the conducting wall of the shielding room was kept at least 80 centimeters from any other grounded conducting surface.
3. Connect EUT to the power mains through a line impedance stabilization network (LISN).
4. All the support units are connecting to the other LISN.
5. The LISN provides 50 ohm coupling impedance for the measuring instrument.
6. The FCC states that a 50 ohm, 50 microhenry LISN should be used.
7. Both sides of AC line were checked for maximum conducted interference.
8. The frequency range from 150 kHz to 30 MHz was searched.
9. Set the test-receiver system to Peak Detect Function and specified bandwidth with Maximum Hold Mode.

The RBW/VBW for 150KHz to 30MHz: 9KHz

TEST RESULTS

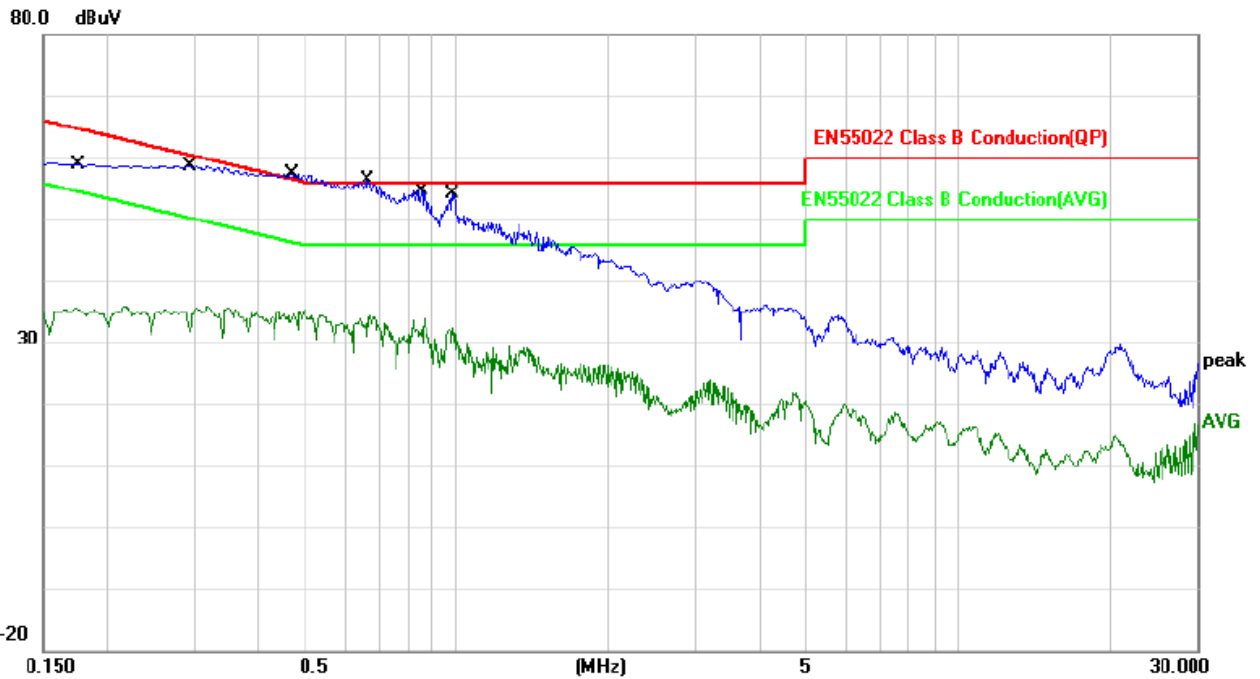

Site Chamber #1

Phase: **L1**

Temperature: 25

Limit: EN55022 Class B Conduction(QP)

Power: AC 120V/60Hz

Humidity: 41 %

EUT: android sticker

M/N: minibox

Mode: On

Note:

No.	Mk.	Freq. MHz	Reading Level dBuV	Correct Factor dB	Measure- ment dBuV	Limit dBuV	Over dB	Detector	Comment
1		0.1788	54.11	-0.13	53.98	64.54	-10.56	QP	
2		0.1788	29.92	-0.13	29.79	54.54	-24.75	AVG	
3		0.2925	53.46	-0.01	53.45	60.45	-7.00	QP	
4		0.2925	29.71	-0.01	29.70	50.45	-20.75	AVG	
5	*	0.4696	52.20	-0.02	52.18	56.52	-4.34	QP	
6		0.4696	29.08	-0.02	29.06	46.52	-17.46	AVG	
7		0.6615	50.49	-0.05	50.44	56.00	-5.56	QP	
8		0.6615	28.41	-0.05	28.36	46.00	-17.64	AVG	
9		0.8425	48.94	-0.08	48.86	56.00	-7.14	QP	
10		0.8425	27.92	-0.08	27.84	46.00	-18.16	AVG	
11		0.9787	48.16	-0.12	48.04	56.00	-7.96	QP	
12		0.9787	27.65	-0.12	27.53	46.00	-18.47	AVG	

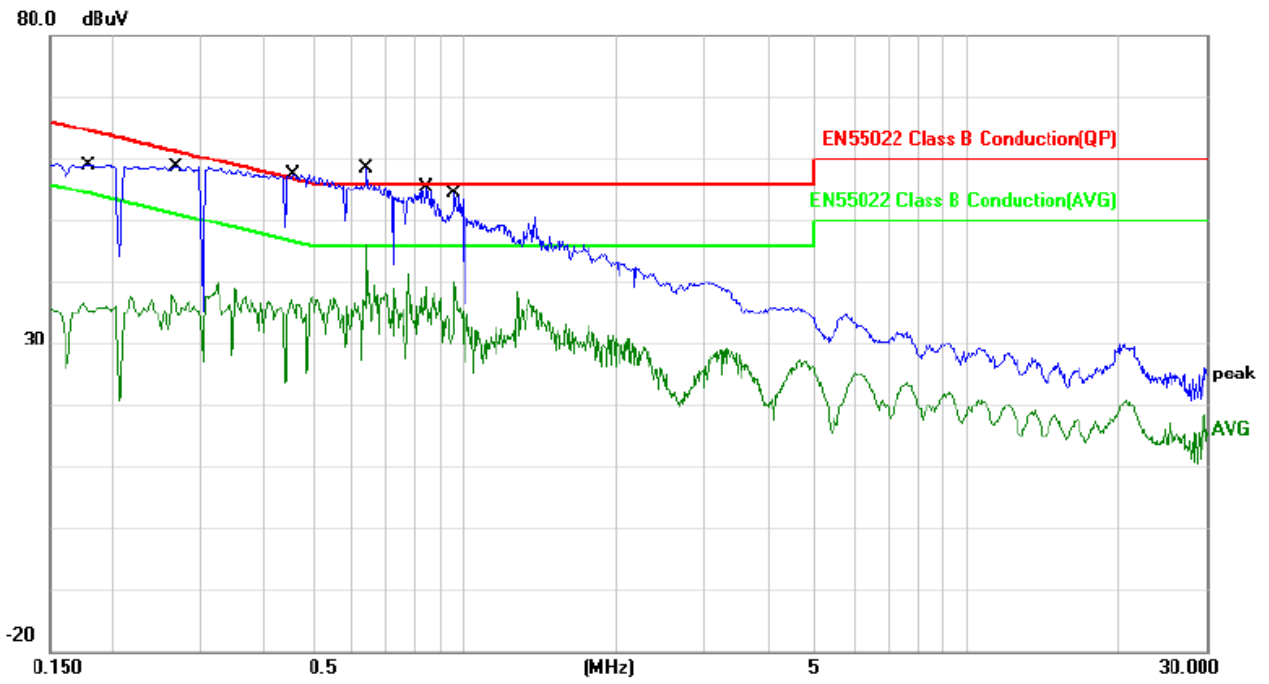

Site Chamber #1 Phase: **N** Temperature: 25
 Limit: EN55022 Class B Conduction(QP) Power: AC 120V/60Hz Humidity: 41 %
 EUT: android sticker
 M/N: minibox
 Mode: On
 Note:

No.	Mk.	Freq. MHz	Reading Level dBuV	Correct Factor dB	Measure- ment dBuV	Limit dBuV	Over dB	Detector	Comment
1		0.1780	54.00	-0.13	53.87	64.57	-10.70	QP	
2		0.1780	30.93	-0.13	30.80	54.57	-23.77	AVG	
3		0.2640	53.47	-0.11	53.36	61.30	-7.94	QP	
4		0.2640	31.58	-0.11	31.47	51.30	-19.83	AVG	
5		0.4588	52.02	-0.02	52.00	56.71	-4.71	QP	
6		0.4588	30.95	-0.02	30.93	46.71	-15.78	AVG	
7		0.6368	52.30	-0.05	52.25	56.00	-3.75	QP	
8	*	0.6368	42.60	-0.05	42.55	46.00	-3.45	AVG	
9		0.8372	48.84	-0.08	48.76	56.00	-7.24	QP	
10		0.8372	35.34	-0.08	35.26	46.00	-10.74	AVG	
11		0.9570	48.29	-0.11	48.18	56.00	-7.82	QP	
12		0.9570	39.50	-0.11	39.39	46.00	-6.61	AVG	

1.18. Radiated Emission and Bandedge Test

TEST CONFIGURATION

(A) Radiated Emission Test Set-Up, Frequency Below 30MHz

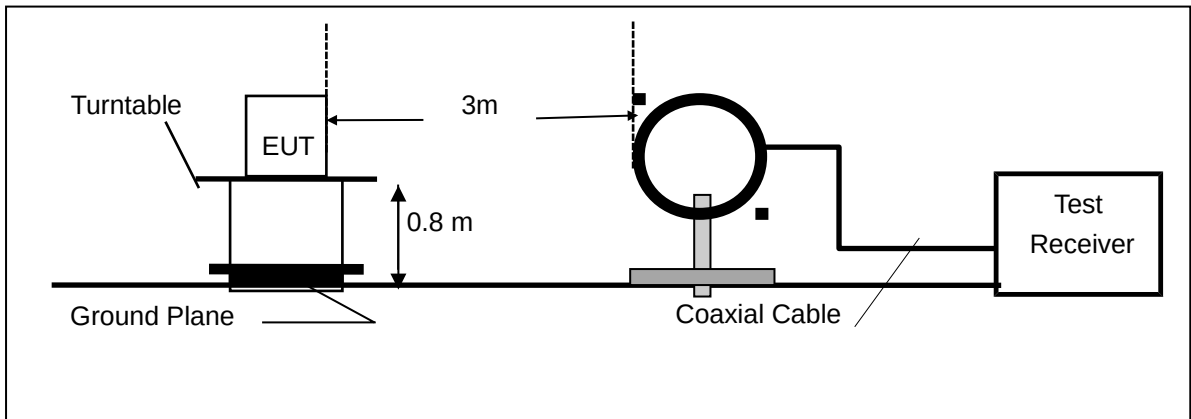

(B) Radiated Emission Test Set-Up, Frequency Below 1000MHz

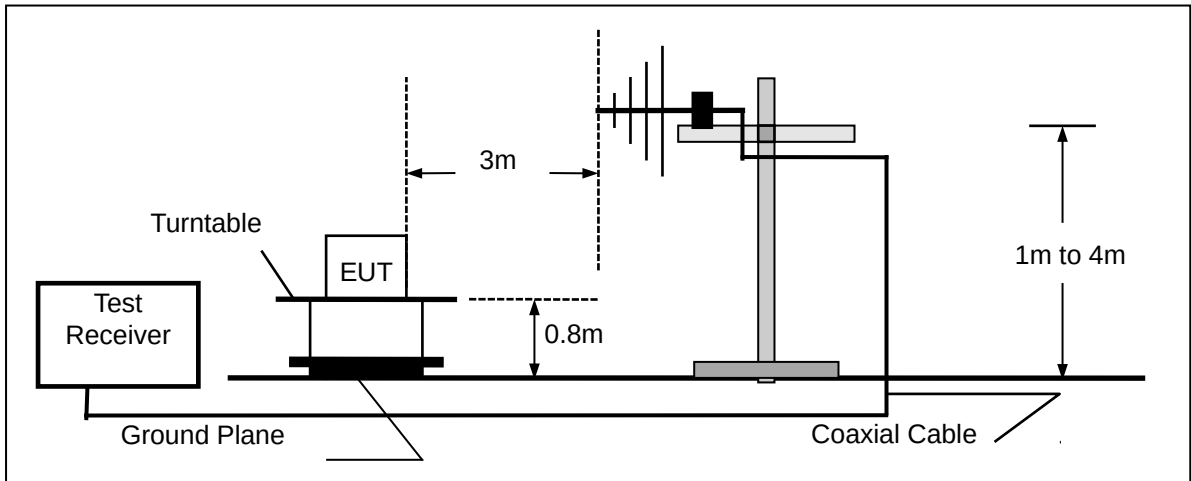

(C) Radiated Emission Test Set-Up, Frequency above 1000MHz

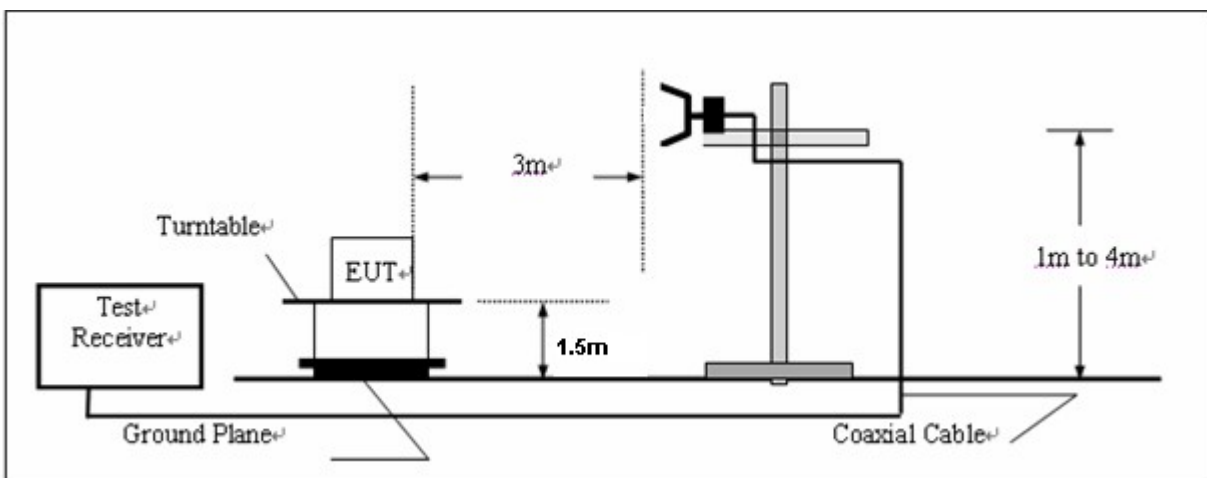

FIELD STRENGTH CALCULATION

The field strength is calculated by adding the Antenna Factor and Cable Factor and subtracting the Amplifier Gain and Duty Cycle Correction Factor(if any) from the measured reading. The basic equation with a sample calculation is as follows:

$$FS = RA + AF + CL - AG$$

Where FS = Field Strength	CL = Cable Attenuation Factor (Cable Loss)
RA = Reading Amplitude	AG = Amplifier Gain
AF = Antenna Factor	

TEST PROCEDURE

1. The testing follows FCC KDB Publication No. 558074 D01 v03r02 (Measurement Guidelines of DTS).
2. The EUT was placed on a turn table which is 0.8m above ground plane.
3. Maximum procedure was performed by raising the receiving antenna from 1m to 4m and rotating the turn table from 0° to 360° to acquire the highest emissions from EUT
4. And also, each emission was to be maximized by changing the polarization of receiving antenna both horizontal and vertical.
5. Span = wide enough to fully capture the emission being measured; RBW = 1 MHz for f >1 GHz, 100 kHz for f < 1 GHz; VBW ≥ RBW; Sweep = auto; Detector function = peak; Trace = max hold.
6. Repeat above procedures until all frequency measurements have been completed.

Note:

When doing emission measurement above 1GHz, the horn antenna will be bended down a little (as horn antenna has the narrow beamwidth) in order to keeping the antenna in the “cone of radiation” of EUT. The 3dB beamwidth is 60 degrees for H-plane and 90 degrees for E-plane.

LIMIT

For unintentional device, according to § 15.109(a), except for Class A digital devices, the field strength of radiated emissions from unintentional radiators at a distance of 3 meters shall not exceed the following values□

Frequency (MHz)	Distance (Meters)	Radiated (dBµV/m)	Radiated (µV/m)
30-88	3	40.0	100
88-216	3	43.5	150
216-960	3	46.0	200
Above 960	3	54.0	500

For intentional device, according to § 15.209(a), the general requirement of field strength of radiated emissions from intentional radiators at a distance of 3 meters shall not exceed the above table. According to § 15.247(d), in any 100kHz bandwidth outside the frequency band in which the EUT is operating, the radio frequency power that is produced by the intentional radiator shall be at least 20dB below that in the100kHz bandwidth within the band that contains the highest level of desired power.

TEST RESULTS

9KHz-30MHz:

Freq. (MHz)	Level (dBuV)	Over Limit (dB)	Limit Line (dBuV)	Remark
-	-	-	-	See Note

Note: The amplitude of spurious emissions that are attenuated by more than 20dB below the permissible value has no need to be reported.

Distance extrapolation factor= 40 log (specific distance/ test distance) (dB);
 Limit line= specific limits (dBuV) + distance extrapolation factor.

Below 1GHz:

The radiated measurement are performed the each test mode (b/g/n) and channel (low/mid/high), the datum recorded below (802.11b mode, the middle channel) is the worst case for all the test mode and channel.

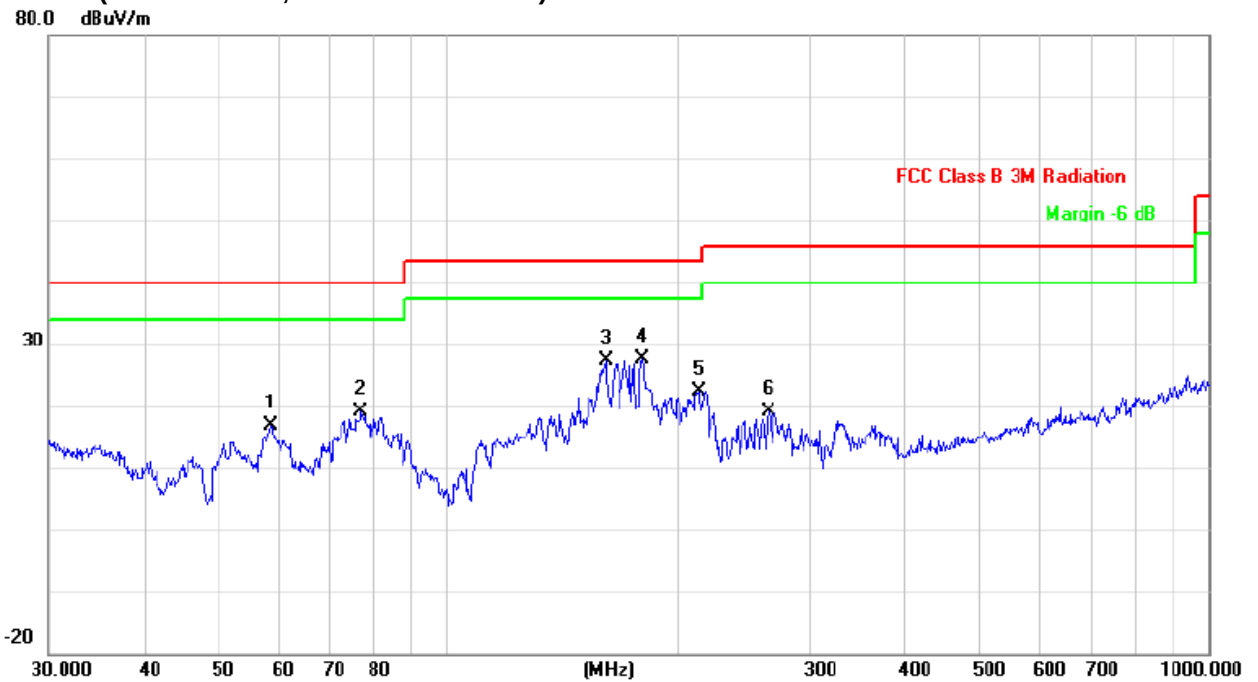

Site Chamber #1

Polarization: *Horizontal*

Temperature:

Limit: FCC Class B 3M Radiation

Power: AC 120V/60Hz

Humidity: %

EUT: android sticker

Distance: 3m

M/N: minibox

Mode:

Note:

No.	Mk.	Freq. (MHz)	Reading Level (dBuV)	Correct Factor (dB/m)	Measurement (dBuV/m)	Limit (dBuV/m)	Over (dB)	Antenna Height (cm)	Table Degree (degree)	Comment
1		58.6126	37.49	-20.70	16.79	40.00	-23.21	peak		
2		77.0503	39.84	-20.83	19.01	40.00	-20.99	peak		
3		161.4740	41.69	-14.36	27.33	43.50	-16.17	peak		
4	*	180.0165	43.51	-15.93	27.58	43.50	-15.92	peak		
5		213.7632	38.70	-16.34	22.36	43.50	-21.14	peak		
6		263.8190	33.58	-14.51	19.07	46.00	-26.93	peak		

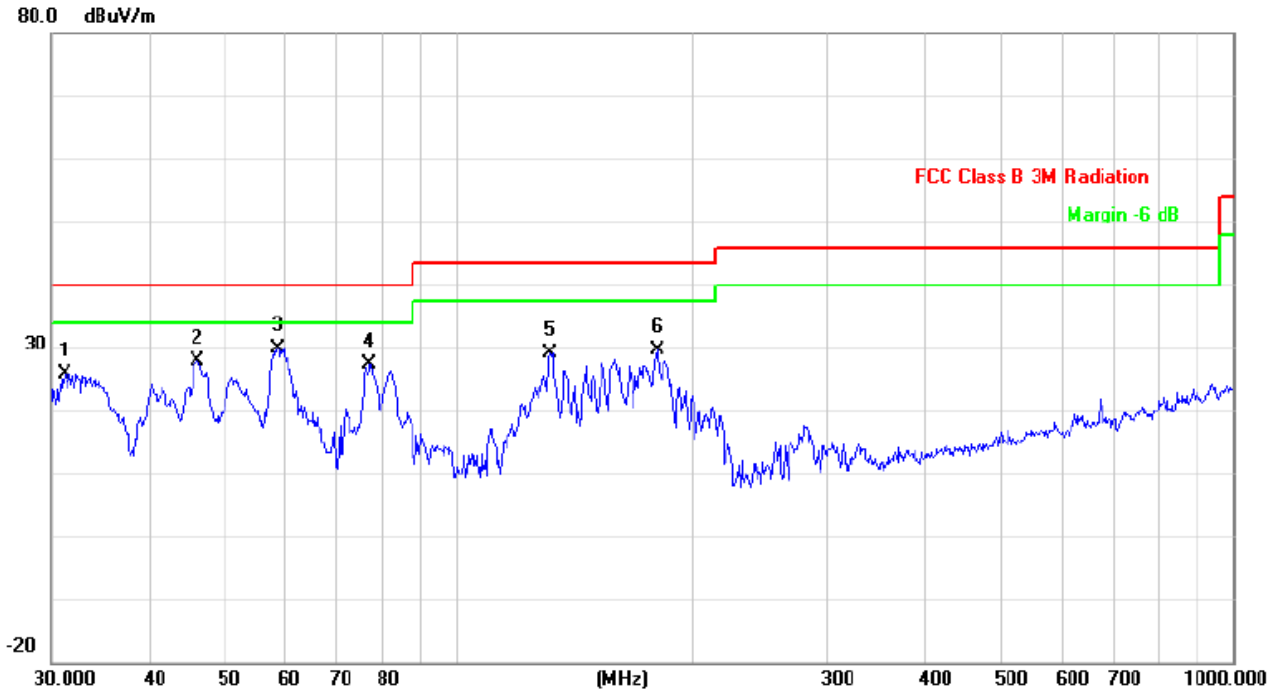

Site Chamber #1

Polarization: **Vertical**

Temperature:

Limit: FCC Class B 3M Radiation

Power: AC 120V/60Hz

Humidity: %

EUT: android sticker

Distance: 3m

M/N: minibox

Mode:

Note:

No.	Mk.	Freq. MHz	Reading Level dBuV	Correct Factor dB/m	Measure- ment dBuV/m	Limit dBuV/m	Over dB	Detector	Antenna Height cm	Table Degree	Comment
1		31.1798	34.14	-8.22	25.92	40.00	-14.08	peak			
2		46.1779	46.47	-18.55	27.92	40.00	-12.08	peak			
3	*	58.6126	50.60	-20.70	29.90	40.00	-10.10	peak			
4		77.0503	48.26	-20.83	27.43	40.00	-12.57	peak			
5		131.7575	43.99	-14.79	29.20	43.50	-14.30	peak			
6		180.6486	45.57	-15.98	29.59	43.50	-13.91	peak			

Above 1GHz:

802.11b

CH	Antenna	Frequency (MHz)	Reading Level (dBuV/m)	Factor (dB)	Measure Level (dBuV/m)	Limit (dBuV/m)	Margin (dB)	Detector
1	V	2412	77.6	30.8	108.4	Fundamental	/	PK
	V	3200	13.7	31.1	44.8	54(note3)	9.2	PK
	V	2390	36.9	32.2	69.1	74	4.9	PK
	V	2390	17.9	32.2	50.1	54	3.9	AV
	V	2400	36.3	32.1	68.4	74	5.6	PK
	V	2400	17.1	32.1	49.2	54	4.8	AV
	V	4824	5.9	42.6	48.5	54(note3)	5.5	PK
	V	7236	21.7	46.5	68.2	74	5.8	PK
	V	7236	-0.4	46.5	46.1	54	7.9	AV
H	24000	11.7	38.9	50.6	54	3.4	PK	
6	V	2437	76.6	31.2	107.8	Fundamental	/	PK
	V	3200	11.1	31.1	42.2	54(note3)	11.8	PK
	V	4876	15.5	32.8	48.3	54(note3)	5.7	PK
	V	7311	20.8	46.8	67.6	74	6.4	PK
	V	7311	2.4	46.1	48.5	54	5.5	AV
	H	24000	11.7	38.9	50.6	54	3.4	PK
11	V	2462	76.3	30.9	107.2	Fundamental	/	PK
	V	3200	15.6	31.1	46.7	54(note3)	7.3	PK
	V	2483.5	34.0	30.2	64.2	74	9.8	PK
	V	2483.5	16.0	30.2	46.2	54	7.8	AV
	V	4927	15.6	32.5	48.1	54(note3)	5.9	PK
	V	7386	22.2	46.3	68.5	74	5.5	PK
	V	7386	1.2	46.3	47.5	54	6.5	AV
	H	24000	11.7	38.9	50.6	54	3.4	PK

Note: 1. Measure Level = Reading Level + Factor.

2. The test results which are attenuated more than 20 dB below the permissible value limit (the test frequency range: 9kHz~30MHz, 18GHz~25GHz), therefore no data appear in the report.

3. This limit applies for using average detector, if the test result on peak is lower than average limit, then average measurement needn't be performed.

Remark: RBW 1MHz VBW 3MHz peak detector for PK value, RMS detector for AV value

802.11g

CH	Antenna	Frequency (MHz)	Reading Level (dBuV/m)	Factor (dB)	Measure Level (dBuV/m)	Limit (dBuV/m)	Margin (dB)	Detector
1	V	2411.9	74.5	30.8	105.3	Fundamental	/	PK
	V	3200	11.7	31.1	42.8	54(note3)	11.2	PK
	V	2390	36.0	32.2	68.2	74	5.8	PK
	V	2390	19.2	32.2	51.4	54	2.6	AV
	V	2400	37.0	32.1	69.1	74	4.9	PK
	V	2400	16.8	32.1	48.9	54	5.1	AV
	V	4824	4.5	42.6	47.1	54(note3)	6.9	PK
	V	7236	18.8	46.5	65.3	74	8.7	PK
	V	7236	-2.8	46.5	43.7	54	10.3	AV
	H	24000	11.7	38.9	50.6	54	3.4	PK
6	V	2437	73.9	31.2	105.1	Fundamental	/	PK
	V	3200	13.1	31.1	44.2	54(note3)	9.8	PK
	V	4876	13.4	32.8	46.2	54(note3)	7.8	PK
	V	7311	23.4	46.8	70.2	74	3.8	PK
	V	7311	3.6	46.1	49.7	54	4.3	AV
	H	24000	11.7	38.9	50.6	54	3.4	PK
11	V	2462.3	73.3	30.9	104.2	Fundamental	/	PK
	V	3200	11.2	31.1	42.3	54(note3)	11.7	PK
	V	2483.5	38.3	30.2	68.5	74	5.5	PK
	V	2483.5	19.4	30.2	49.6	54	4.4	AV
	V	4927	16.1	32.5	48.6	54(note3)	5.4	PK
	V	7386	23.2	46.3	69.5	74	4.5	PK
	V	7386	1.9	46.3	48.2	54	5.8	AV
	H	24000	11.7	38.9	50.6	54	3.4	PK

Note: 1. Measure Level = Reading Level + Factor.

2. The test results which are attenuated more than 20 dB below the permissible value limit (the test frequency range: 9kHz~30MHz, 18GHz~25GHz), therefore no data appear in the report.

3. This limit applies for using average detector, if the test result on peak is lower than average limit, then average measurement needn't be performed.

Remark: RBW 1MHz VBW 3MHz peak detector for PK value, RMS detector for AV value

802.11n(20MHz)

CH	Antenna	Frequency (MHz)	Reading Level (dBUV/m)	Factor (dB)	Measure Level (dBUV/m)	Limit (dBUV/m)	Margin (dB)	Detector
1	V	2411.9	73.0	30.8	103.8	Fundamental	/	PK
	V	3200	13.8	31.1	44.9	54(note3)	9.1	PK
	V	2390	32.0	32.2	64.2	74	9.8	PK
	V	2390	16.7	32.2	48.9	54	5.1	AV
	V	2400	38.0	32.1	70.1	74	3.9	PK
	V	2400	18.2	32.1	50.3	54	3.7	AV
	V	4824	6.9	42.6	49.5	54(note3)	4.5	PK
	V	7236	22.9	46.5	69.4	74	4.6	PK
	V	7236	1.7	46.5	48.2	54	5.8	AV
	H	24000	11.7	38.9	50.6	54	3.4	PK
6	V	2437	72.8	31.2	104.0	Fundamental	/	PK
	V	3200	12.5	31.1	43.6	54(note3)	10.4	PK
	V	4876	15.3	32.8	48.1	54(note3)	5.9	PK
	V	7311	22.3	46.8	69.1	74	4.9	PK
	V	7311	3.5	46.1	49.6	54	4.4	AV
	H	24000	11.7	38.9	50.6	54	3.4	PK
11	V	2462.3	72.3	30.9	103.2	Fundamental	/	PK
	V	3200	16.1	31.1	47.2	54(note3)	6.8	PK
	V	2483.5	34.3	30.2	64.5	74	9.5	PK
	V	2483.5	11.4	30.2	41.6	54	12.4	AV
	V	4927	16.3	32.5	48.8	54(note3)	5.2	PK
	V	7386	21.0	46.3	67.3	74	6.7	PK
	V	7386	1.1	46.3	47.4	54	6.6	AV
	H	24000	11.7	38.9	50.6	54	3.4	PK

Note: 1. Measure Level = Reading Level + Factor.

2. The test results which are attenuated more than 20 dB below the permissible value limit (the test frequency range: 9kHz~30MHz, 18GHz~25GHz), therefore no data appear in the report.

3. This limit applies for using average detector, if the test result on peak is lower than average limit, then average measurement needn't be performed.

Remark: RBW 1MHz VBW 3MHz peak detector for PK value, RMS detector for AV value

1.19. 6dB Bandwidth Measurement

TEST CONFIGURATION

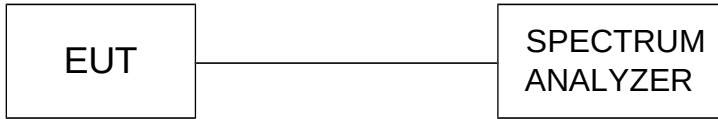

TEST PROCEDURE

1. The testing follows FCC KDB Publication No. 558074 D01 v03r02 (Measurement Guidelines of DTS).
2. The RF output of EUT was connected to the spectrum analyzer by a low loss cable.
3. Make the measurement with the spectrum analyzer's resolution bandwidth (RBW) = 100 kHz. In order to make an accurate measurement, set the span greater than RBW. The 6 dB bandwidth must be greater than 500 kHz.
4. The marker-delta reading at this point is the 6 dB bandwidth of the emission.

LIMIT

For digital modulation systems, the minimum 6 dB bandwidth shall be at least 500 kHz.

TEST RESULTS

Product	:	ANDROID STICKER
Test Item	:	6dB Occupied Bandwidth
Test Mode	:	Mode 1: Transmit by 802.11b

Channel No.	Frequency (MHz)	Occupied Bandwidth (kHz)	Limit (kHz)	Result
01	2412	8580	500	Pass
06	2437	9480	500	Pass
11	2462	8700	500	Pass

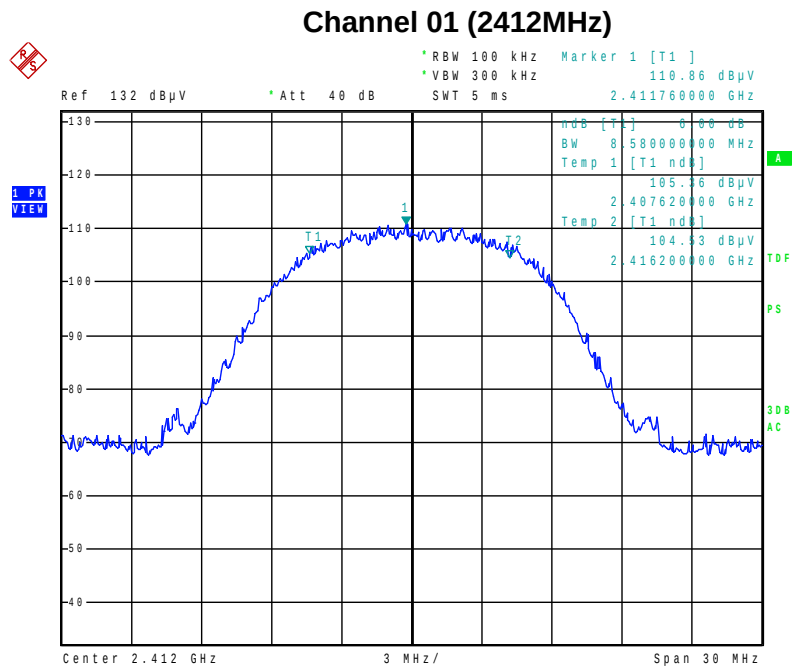

Channel 06 (2437MHz)

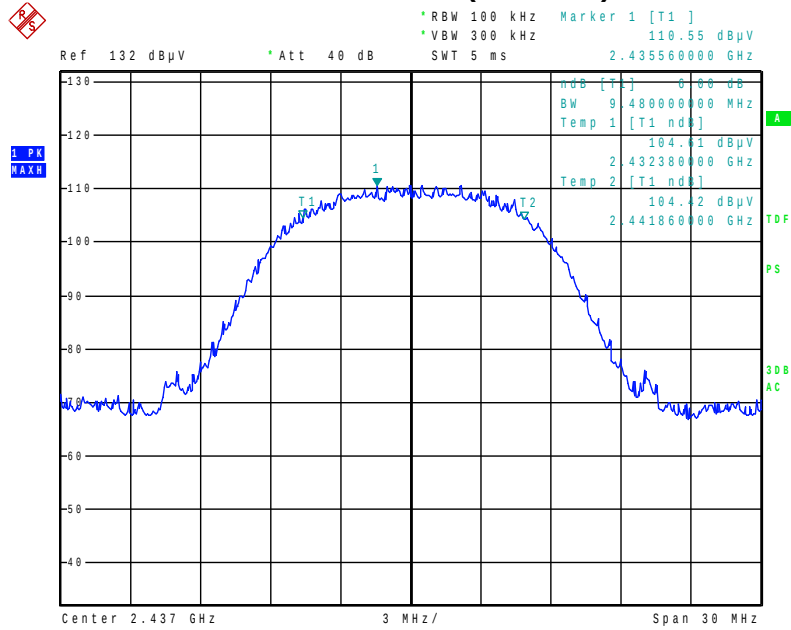

Date: 1.DEC.2015 11:23:53

Channel 11 (2462MHz)

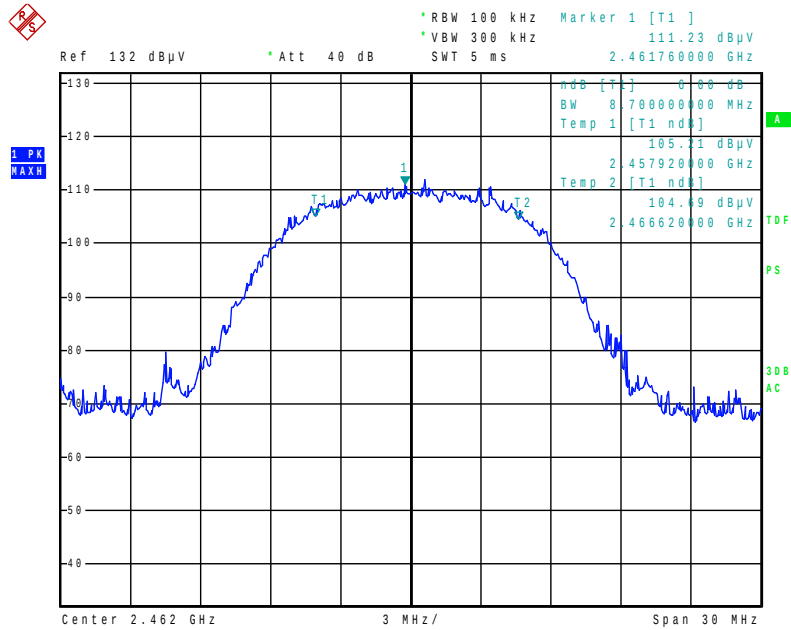

Date: 1.DEC.2015 11:24:14

Product	:	ANDROID STICKER
Test Item	:	6dB Occupied Bandwidth
Test Mode	:	Mode 2: Transmit by 802.11g

Channel No.	Frequency (MHz)	Occupied Bandwidth (kHz)	Limit (kHz)	Result
01	2412	16260	500	Pass
06	2437	16320	500	Pass
11	2462	16260	500	Pass

Channel 01 (2412MHz)

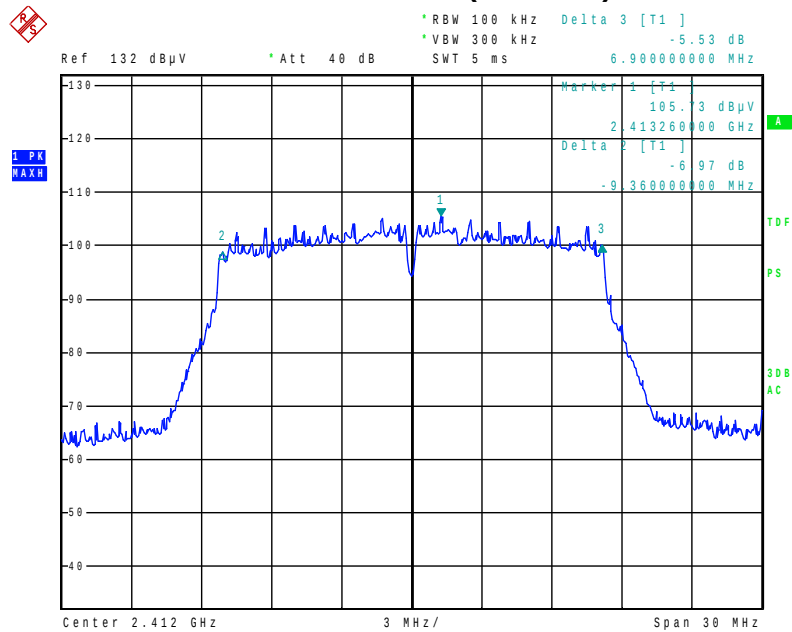

Date: 1.DEC.2015 11:26:03

Channel 06 (2437MHz)

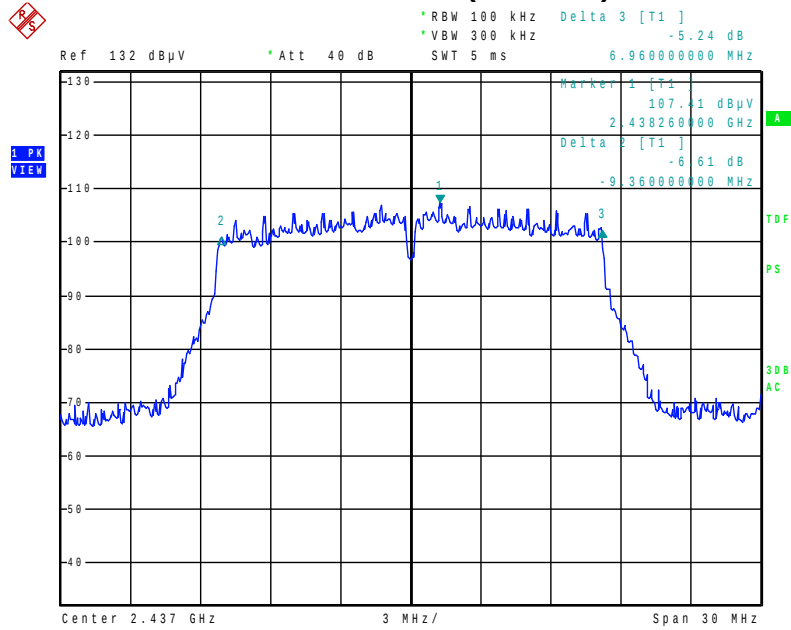

Date: 1.DEC.2015 11:27:00

Channel 11 (2462MHz)

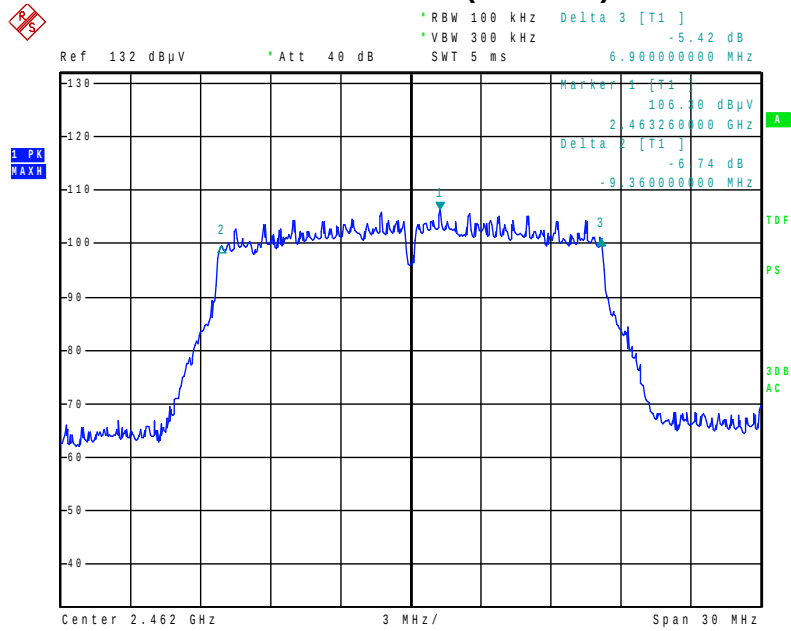

Date: 1.DEC.2015 11:27:44

Channel 06 (2437MHz)

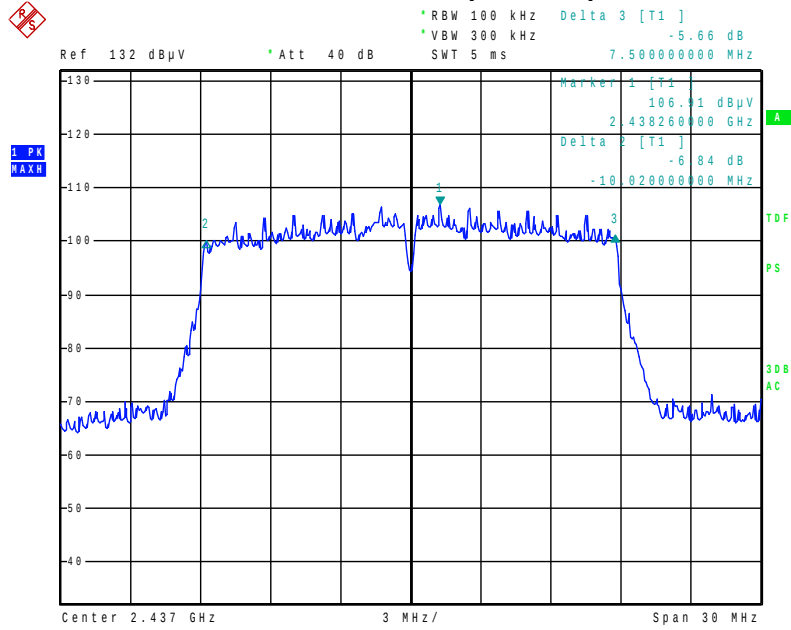

Date: 1.DEC.2015 11:29:22

Channel 11 (2462MHz)

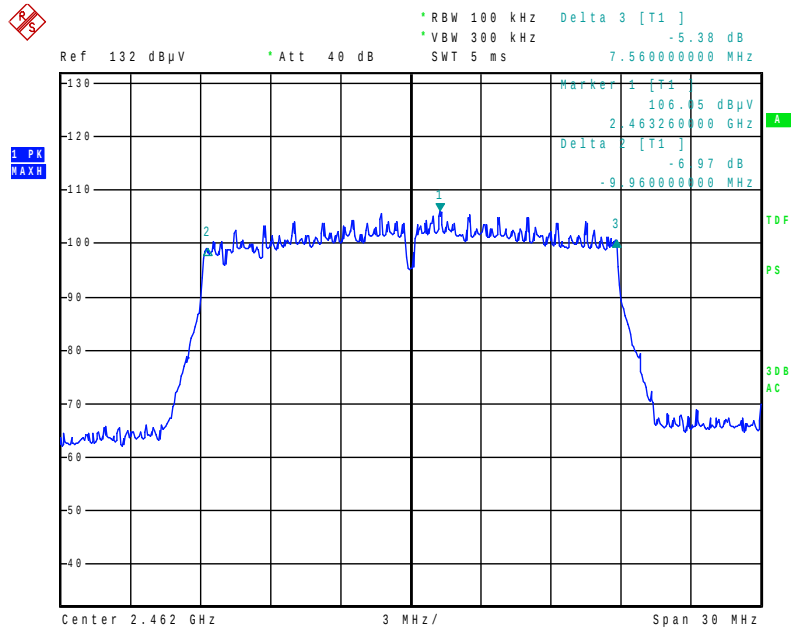

Date: 1.DEC.2015 11:28:42

1.20. Maximum Peak Output Power

TEST CONFIGURATION

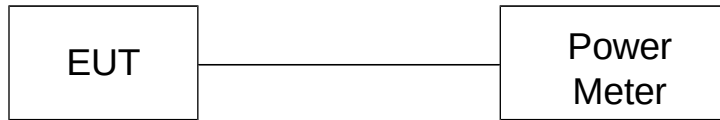

TEST PROCEDURE

According to C63.10 -2013 and KDB558074 D01 v03r02, The EUT was directly connected to the power meter / spectrum analyzer and antenna output port as show in the block diagram as TEST CONFIGURATION shows.

Use the wideband power meter to test peak power and record the result.

LIMIT

The Peak Output Power Measurement limits are 30dBm.

TEST RESULTS

Product	:	ANDROID STICKER
Test Item	:	Power Output
Test Mode	:	Mode 1: Transmit by 802.11b

Channel No.	Frequency (MHz)	Measurement Power Output (dBm)	Limit (dBm)	Result
1	2412	15.33	30.00	Pass
6	2437	15.01	30.00	Pass
11	2462	15.26	30.00	Pass

Product	:	ANDROID STICKER
Test Item	:	Power Output
Test Mode	:	Mode 2: Transmit by 802.11g

Channel No.	Frequency (MHz)	Measurement Power Output (dBm)	Limit (dBm)	Result
1	2412	13.28	30.00	Pass
6	2437	13.04	30.00	Pass
11	2462	12.93	30.00	Pass

Product	:	ANDROID STICKER
Test Item	:	Power Output
Test Mode	:	Mode 3: Transmit by 802.11n(20MHz)

Channel No.	Frequency (MHz)	Measurement Power Output (dBm)	Limit (dBm)	Result
1	2412	12.69	30.00	Pass
6	2437	12.74	30.00	Pass
11	2462	12.90	30.00	Pass

Note: The test results including the cable lose.

1.21. Power Spectral Density Measurement

TEST CONFIGURATION

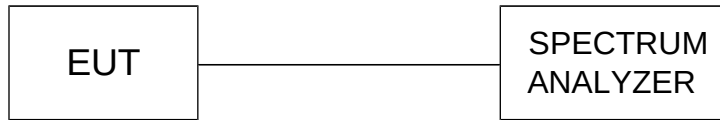

TEST PROCEDURE

The EUT was tested according to KDB558074 D01 v03r02 for compliance to FCC 47CFR 15.247 and requirements. Set RBW= 3 kHz, VBW \geq 10KHz, SPAN to 1.5 times greater than the EBW,.

LIMIT

For digitally modulated systems, the power spectral density conducted from the intentional radiator to the antenna shall not be greater than 8 dBm in any 3 kHz band during any time interval of continuous transmission.

TEST RESULTS

Product	:	ANDROID STICKER
Test Item	:	Power Spectral Density
Test Mode	:	Mode 1: Transmit by 802.11b

Channel No.	Frequency (MHz)	Measurement PPSD (dBm/3KHz)	Limit (dBm/3KHz)	Result
01	2412	-11.44	8	Pass
06	2437	-12.01	8	Pass
11	2462	-10.10	8	Pass

Channel 01 (2412MHz)

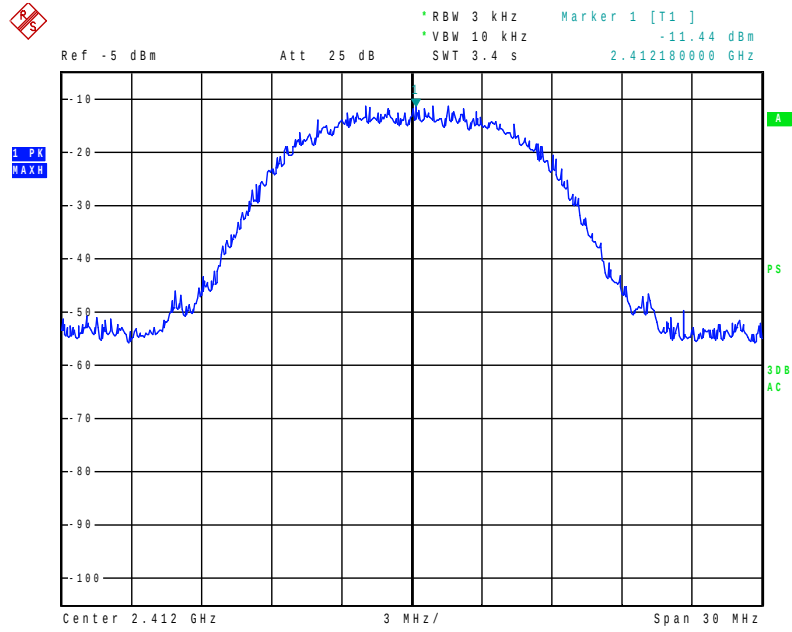

Date: 1.DEC.2015 11:35:59

Channel 06 (2437MHz)

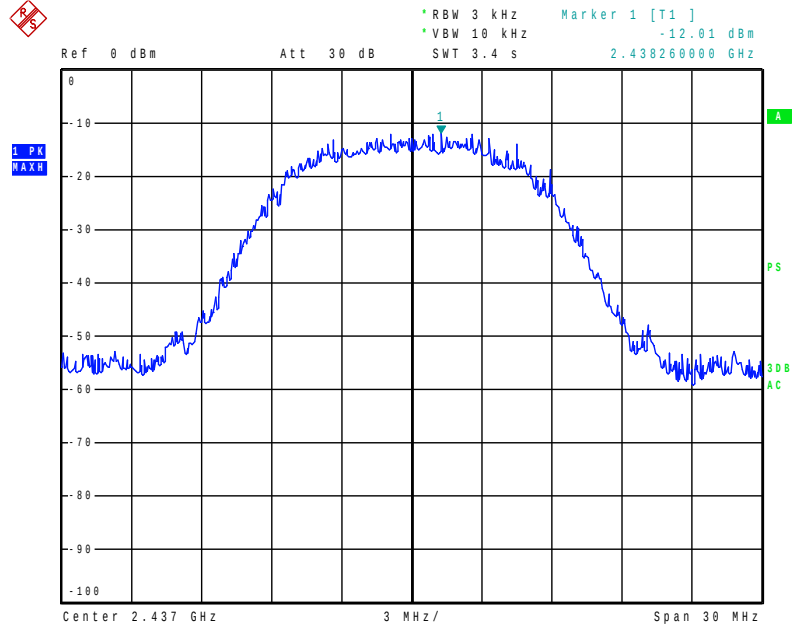

Date: 1.DEC.2015 11:36:56

Channel 11 (2462MHz)

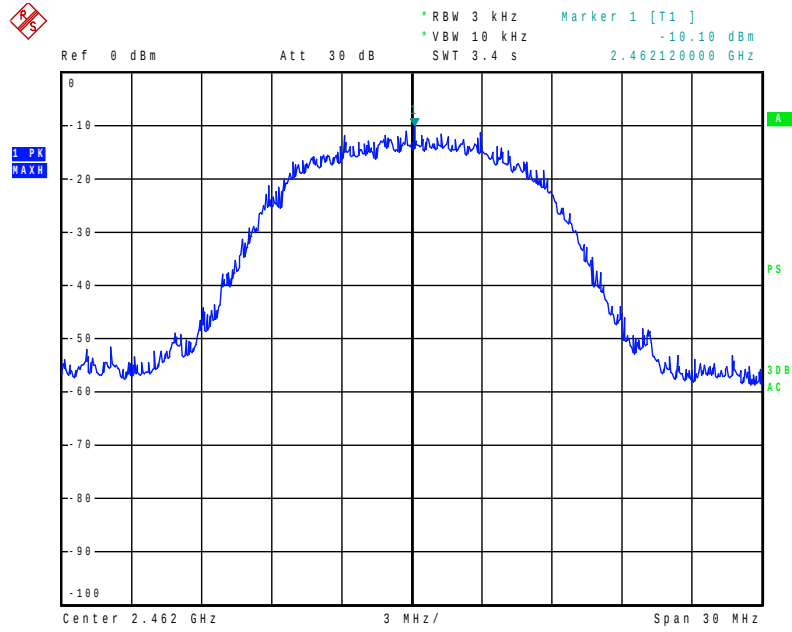

Date: 1.DEC.2015 11:37:27

Product	:	ANDROID STICKER
Test Item	:	Power Spectral Density
Test Mode	:	Mode 2: Transmit by 802.11g

Channel No.	Frequency (MHz)	Measurement PPSD (dBm/3KHz)	Limit (dBm/3KHz)	Result
01	2412	-17.56	8	Pass
06	2437	-16.25	8	Pass
11	2462	-15.93	8	Pass

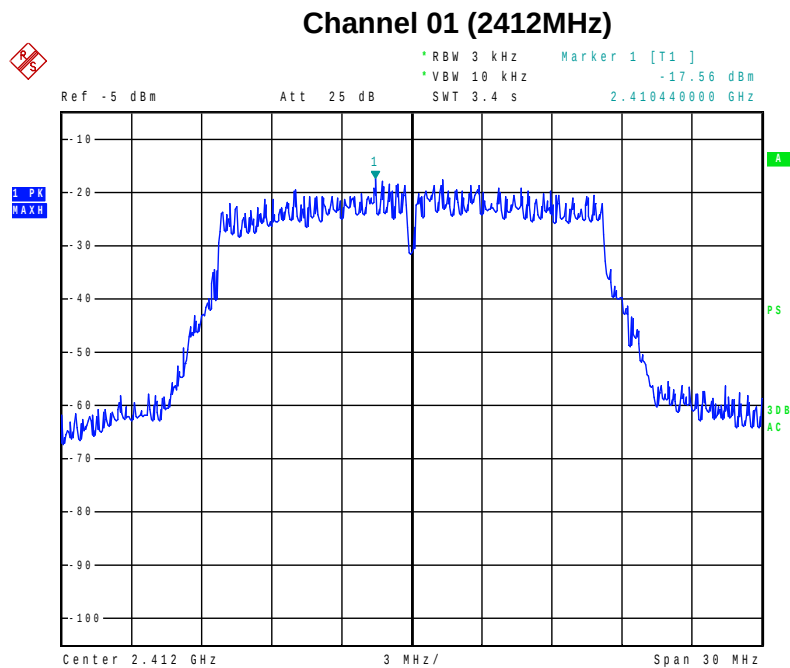

Date: 1.DEC.2015 11:35:09

Channel 06 (2437MHz)

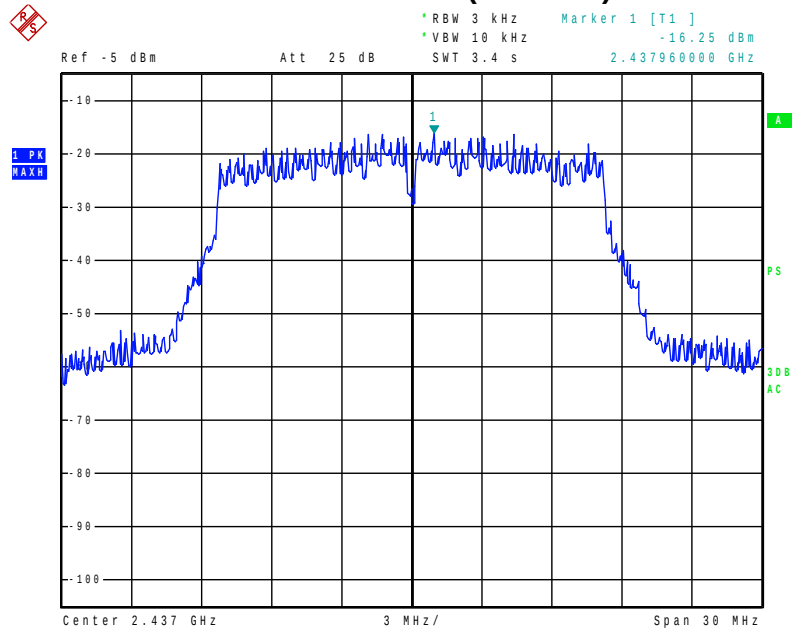

Date: 1.DEC.2015 11:34:49

Channel 11 (2462MHz)

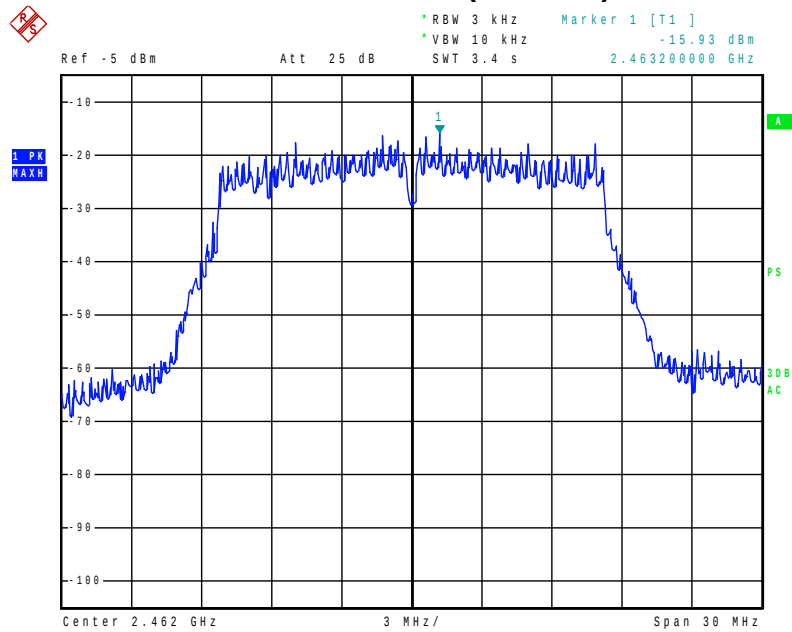

Date: 1.DEC.2015 11:34:28

Product	:	ANDROID STICKER
Test Item	:	Power Spectral Density
Test Mode	:	Mode 3: Transmit by 802.11n (20MHz)

Channel No.	Frequency (MHz)	Measurement PPSD (dBm/3KHz)	Limit (dBm/3KHz)	Result
01	2412	-17.57	8	Pass
06	2437	-16.83	8	Pass
11	2462	-17.31	8	Pass

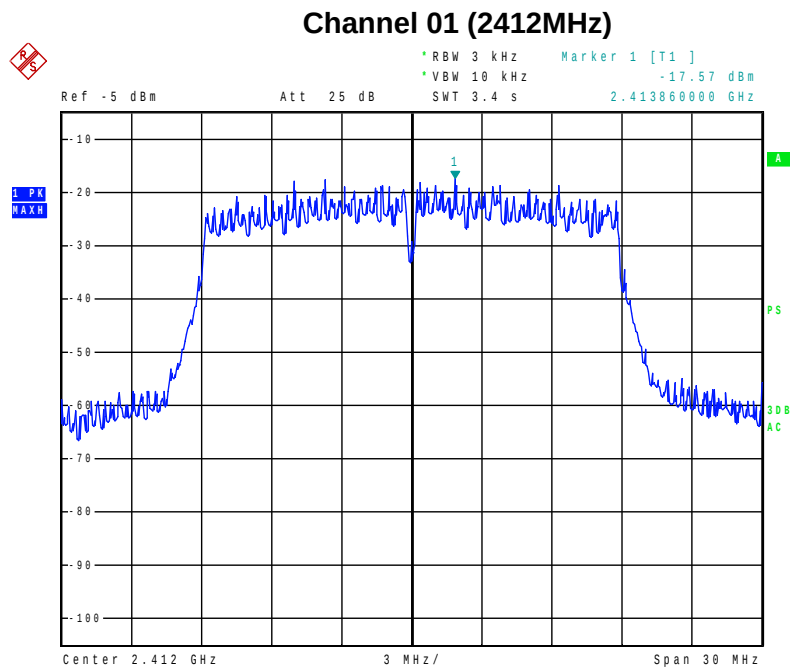

Date: 1.DEC.2015 11:33:05

Channel 06 (2437MHz)

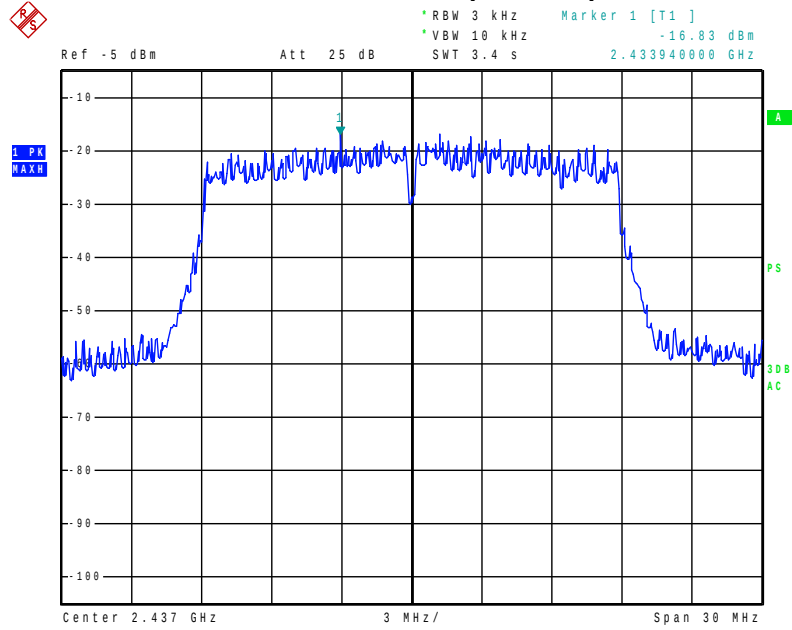

Date: 1.DEC.2015 11:33:35

Channel 11 (2462MHz)

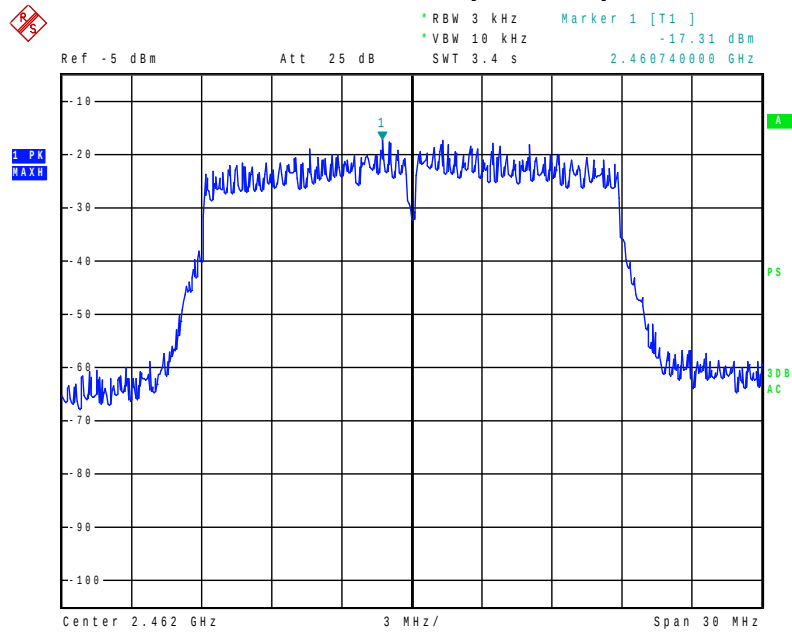

Date: 1.DEC.2015 11:33:55

1.22. Spurious RF Conducted Emission and bandedge

TEST CONFIGURATION

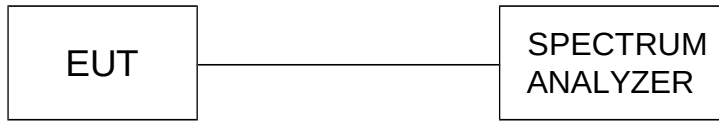

TEST PROCEDURE

The EUT was tested according to KDB558074 D01 v03r02 for compliance to FCC 47CFR 15.247 requirements.

The Spurious RF conducted emissions compliance of RF radiated emission should be measured by following the guidance in ANSI C63.10-2013 with respect to maximizing the emission by rotating the EUT, measuring the emission while the EUT is situated in three orthogonal planes (if appropriate), adjusting the measurement antenna height and polarization etc. Set RBW=100kHz and VBM= 300kHz to measure the peak field strength , and measure frequency range from 30MHz to 26.5GHz.

LIMIT

In any 100 kHz bandwidth outside the frequency band in which the spread spectrum or digitally modulated intentional radiator is operating, the radio frequency power that is produced by the intentional radiator shall be at least 20 dB below that in the 100 kHz bandwidth within the band that contains the highest level of the desired power, based on either an RF conducted or a radiated measurement, provided the transmitter demonstrates compliance with the peak conducted power limits.

TEST RESULTS

Product	:	ANDROID STICKER
Test Item	:	RF Antenna Conducted Spurious
Test Mode	:	Mode 1: Transmit by 802.11b

Channel 01 (2412MHz)

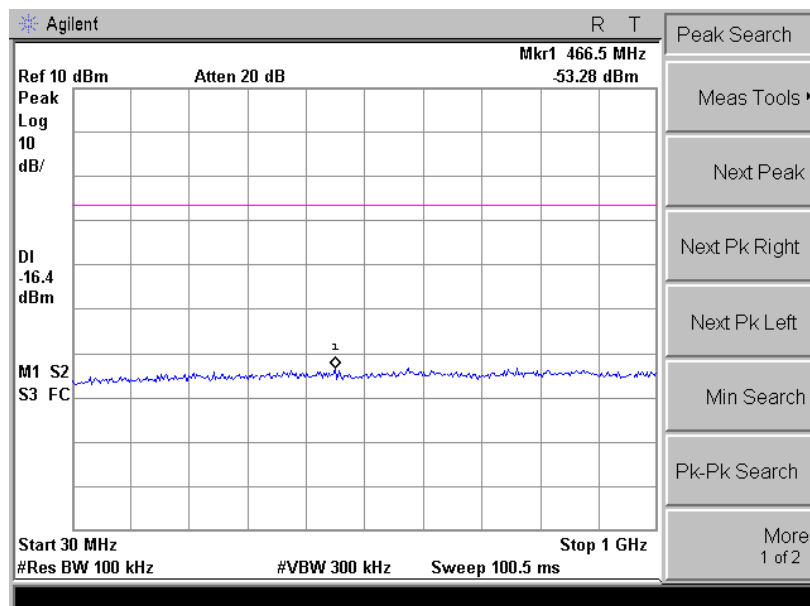

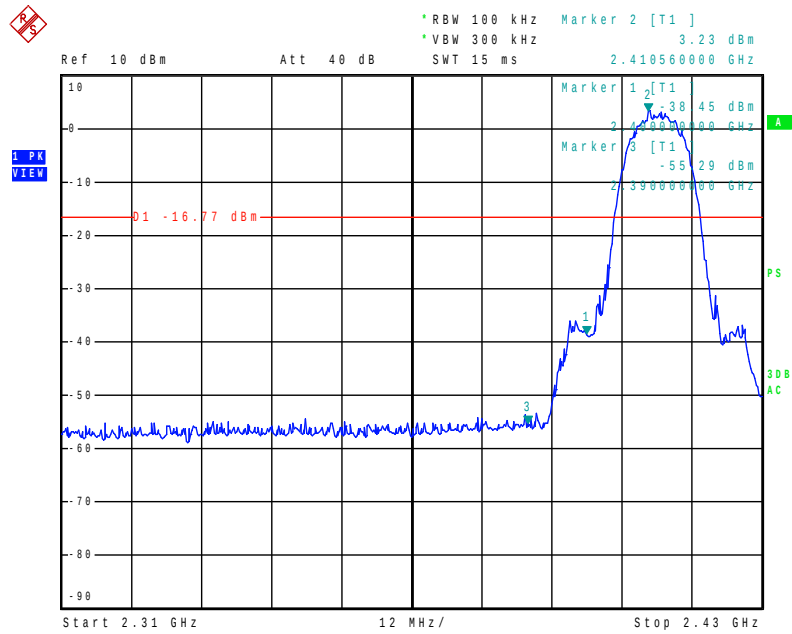
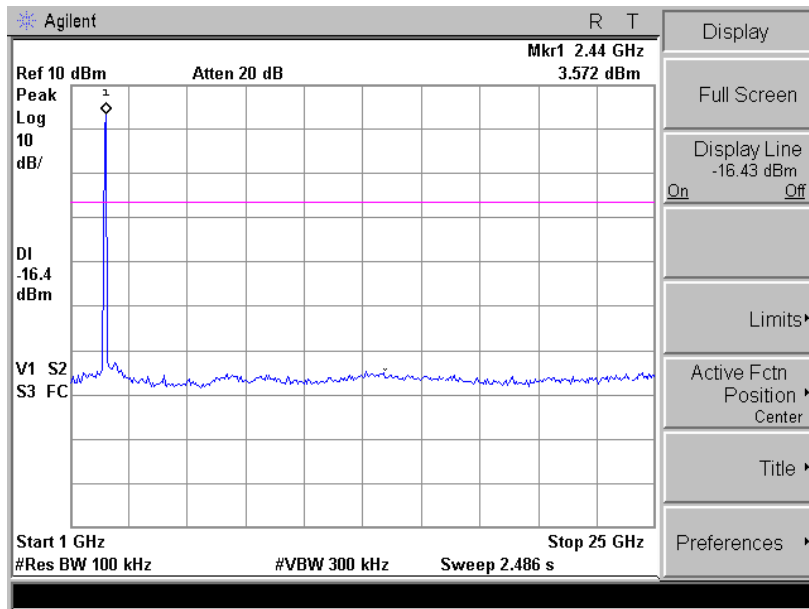

Date: 1.DEC.2015 11:41:29

Channel 06 (2437MHz)

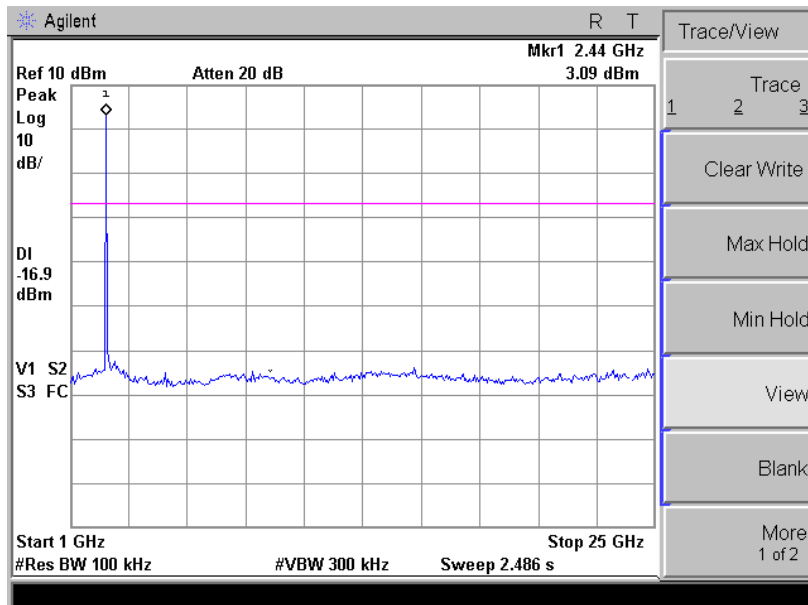
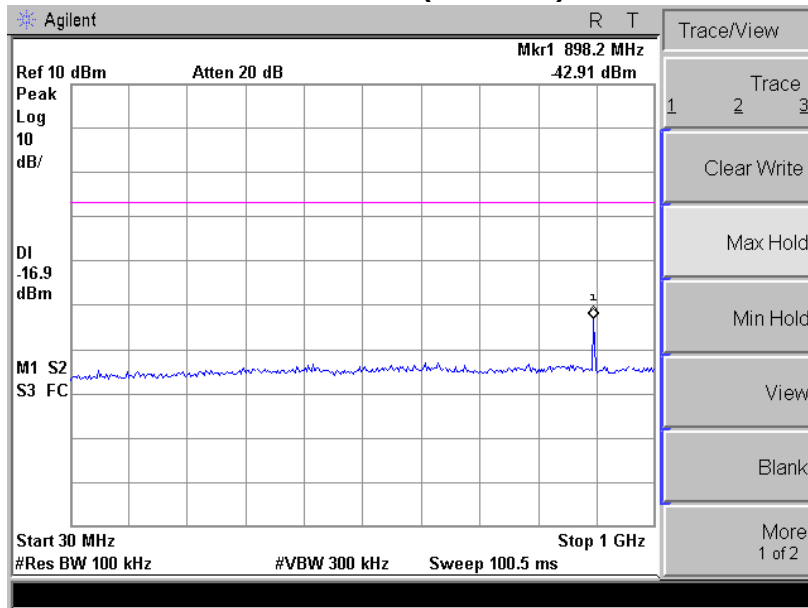

Channel 11 (2462MHz)

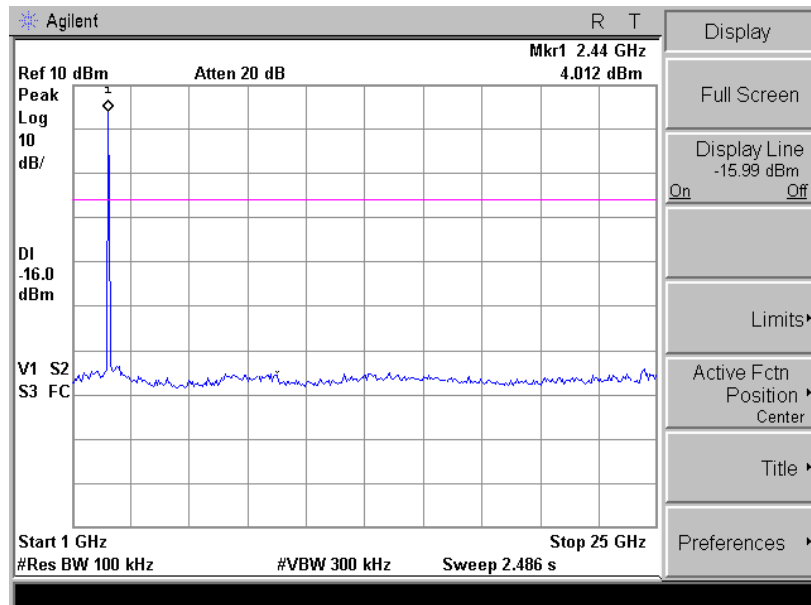
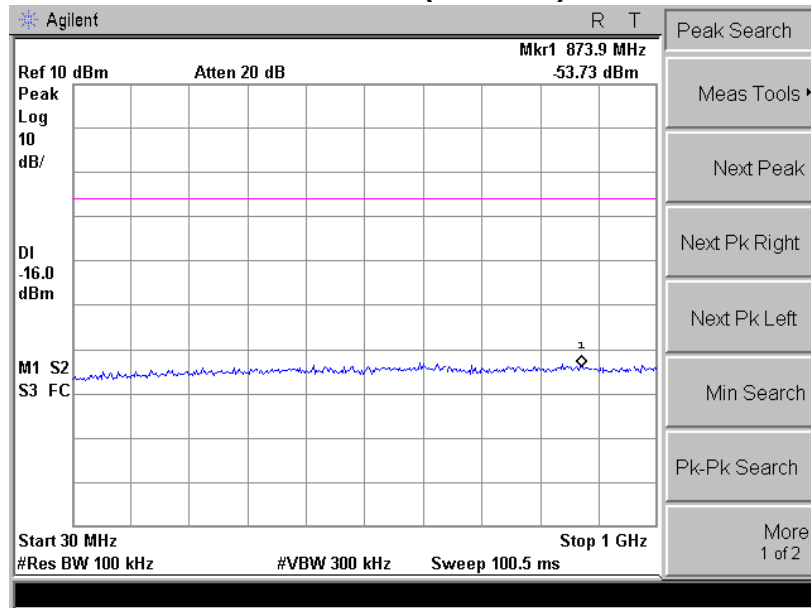

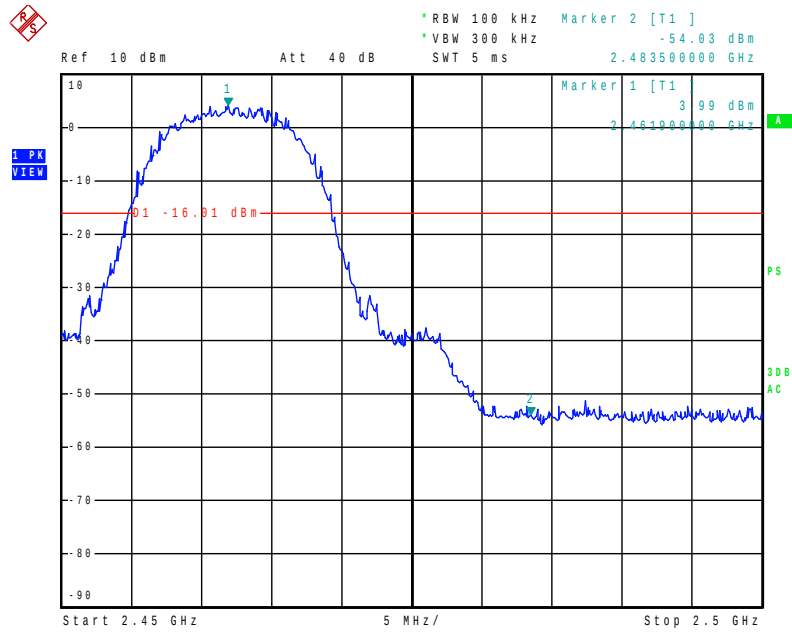

Date: 1.DEC.2015 11:46:54

Product	:	ANDROID STICKER
Test Item	:	RF Antenna Conducted Spurious
Test Mode	:	Mode 2: Transmit by 802.11g

Channel 01 (2412MHz)

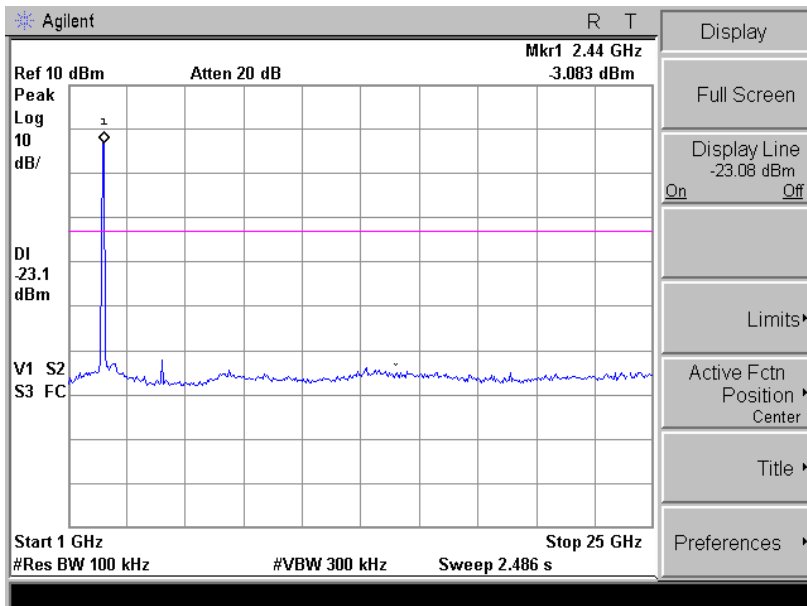
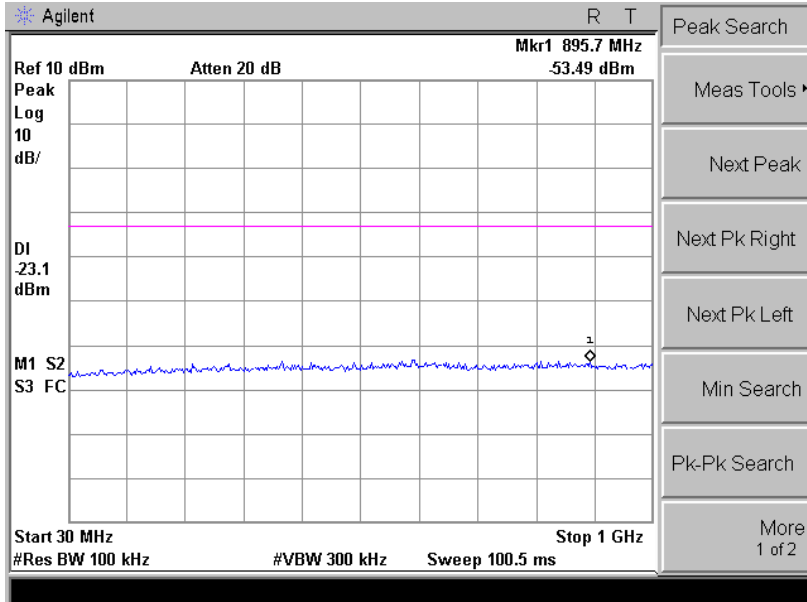

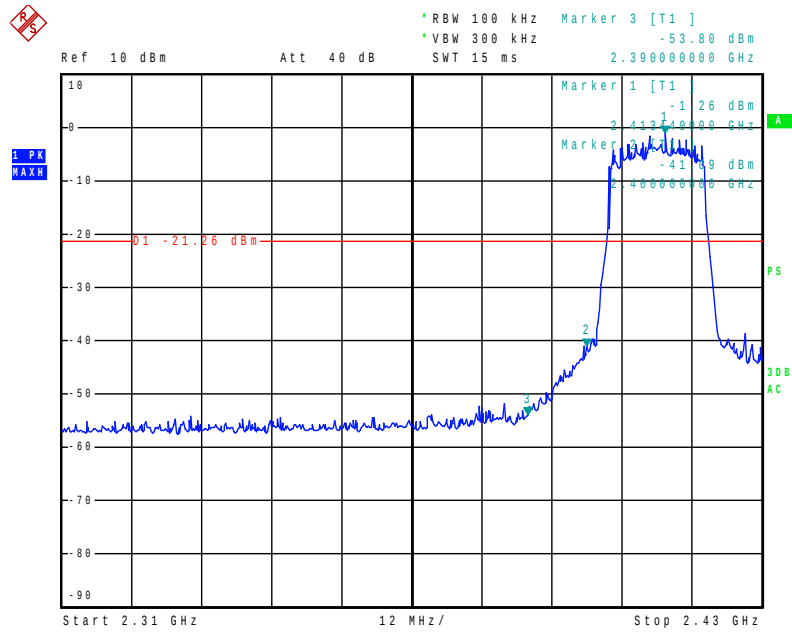

Date: 1.DEC.2015 11:42:30

Channel 06 (2437MHz)

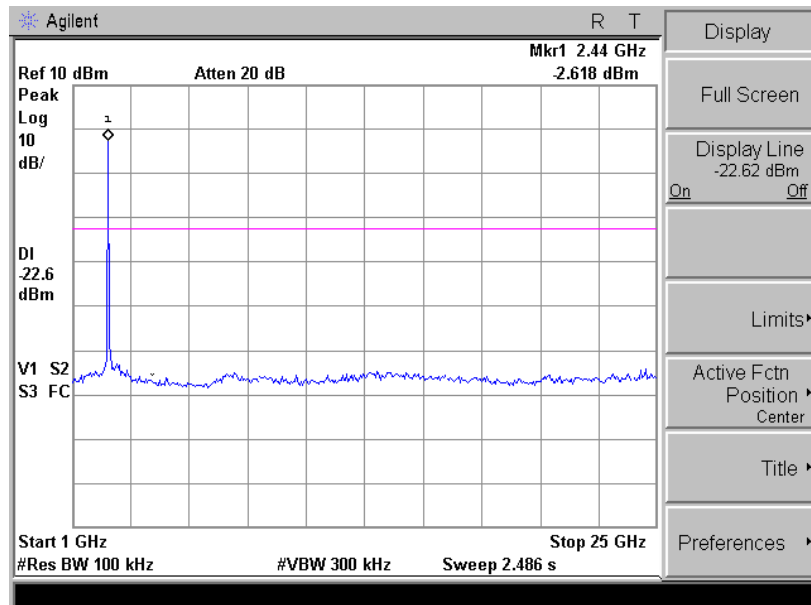
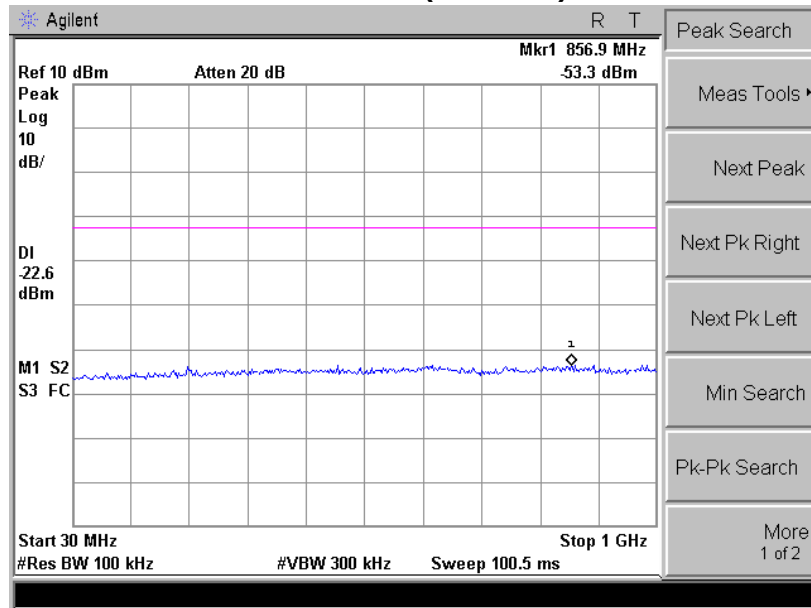

Channel 11 (2462MHz)

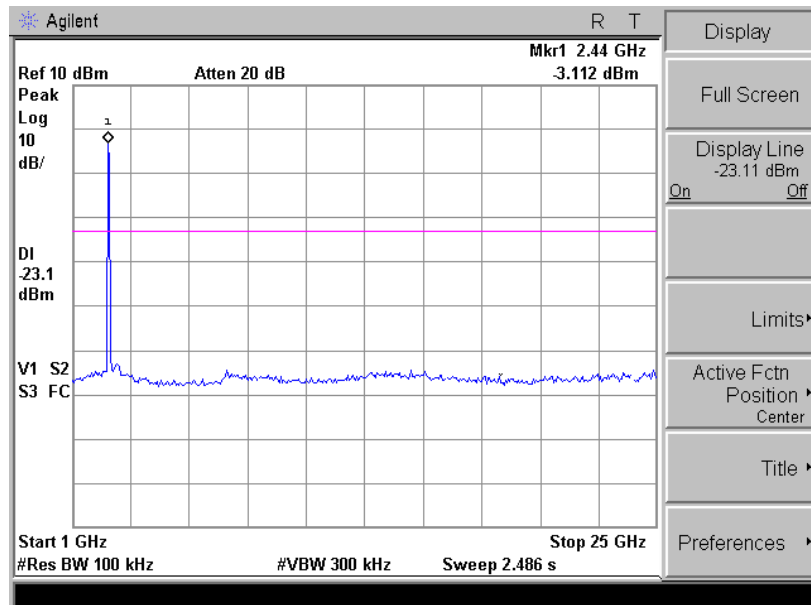
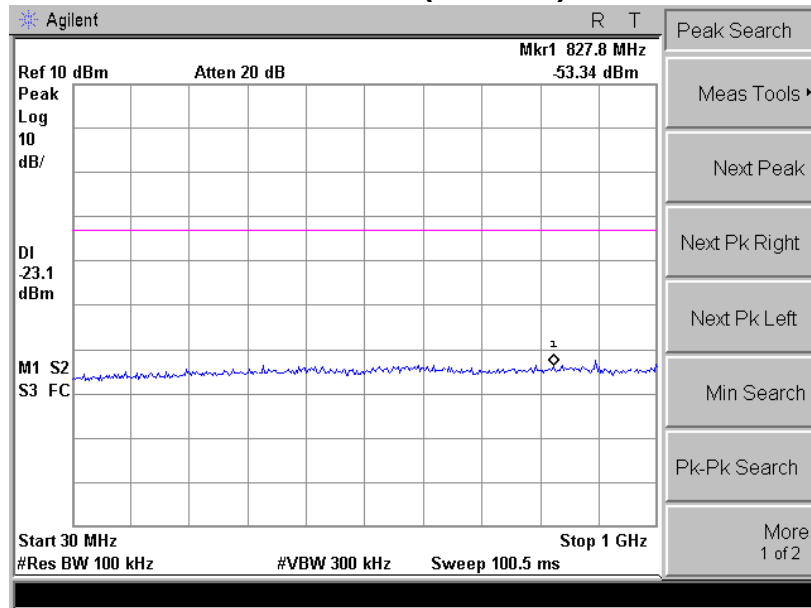

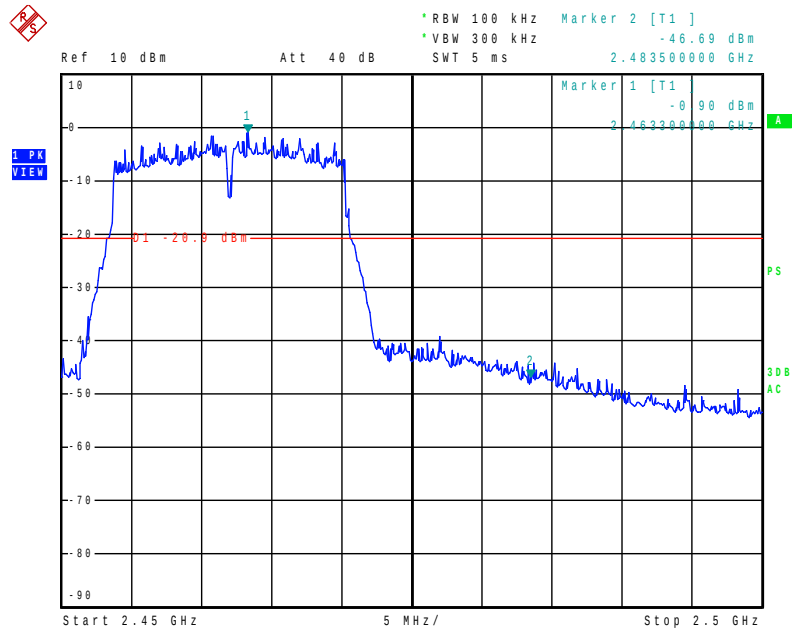

Date: 1.DEC.2015 11:45:45

Product	:	ANDROID STICKER
Test Item	:	RF Antenna Conducted Spurious
Test Mode	:	Mode 3: Transmit by 802.11n (20MHz)

Channel 01 (2412MHz)

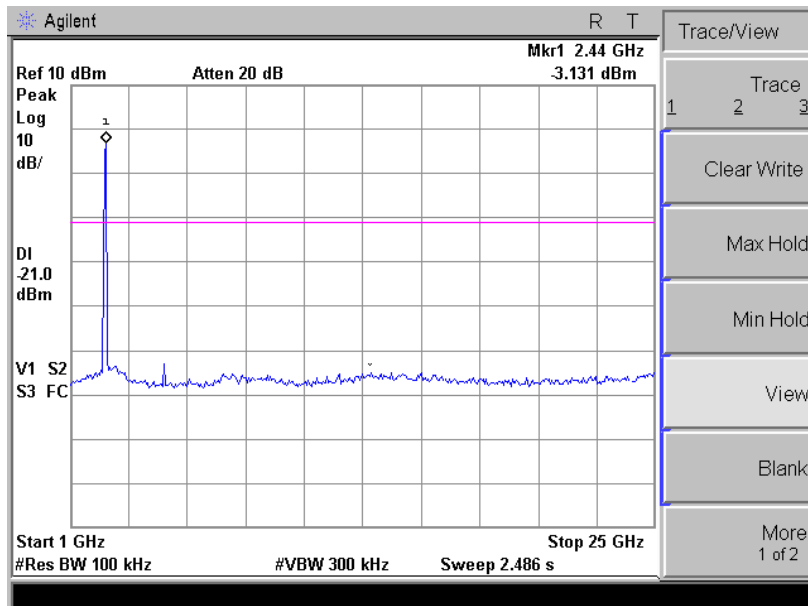
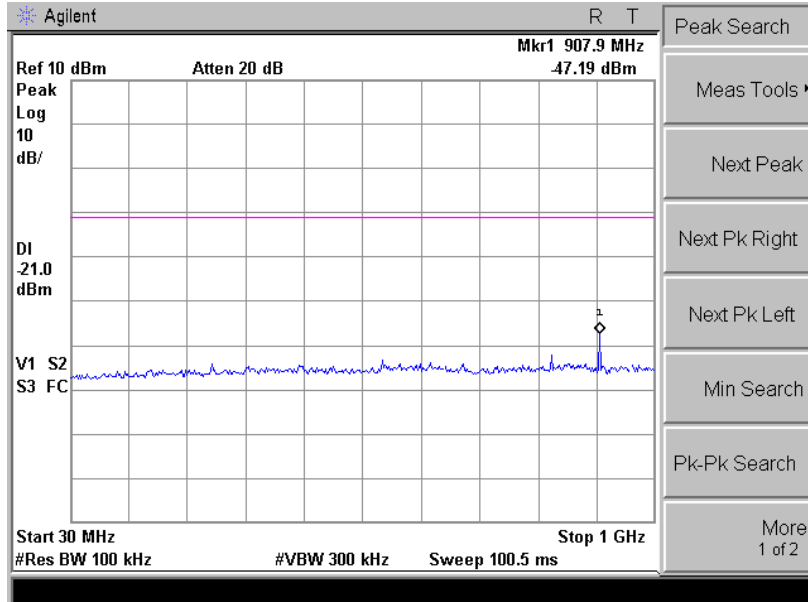

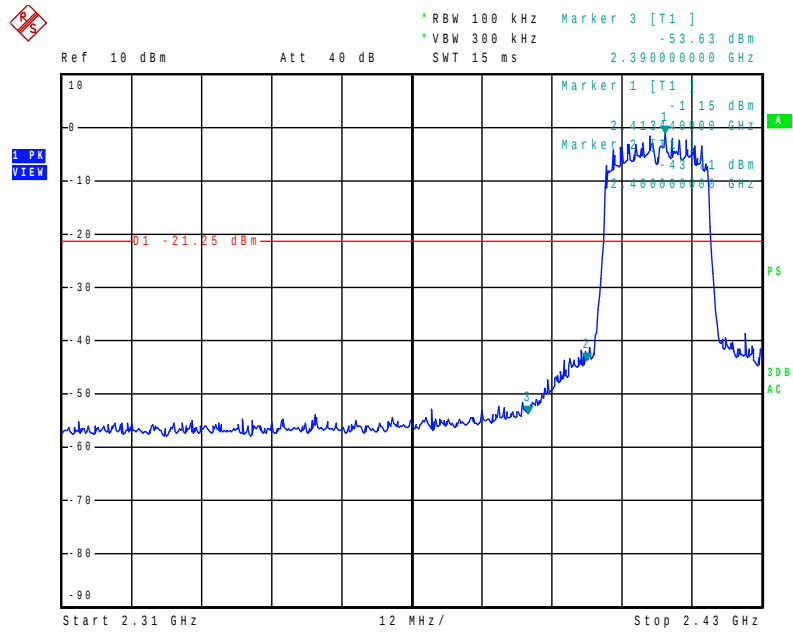

Date: 1.DEC.2015 11:43:53

Channel 06 (2437MHz)

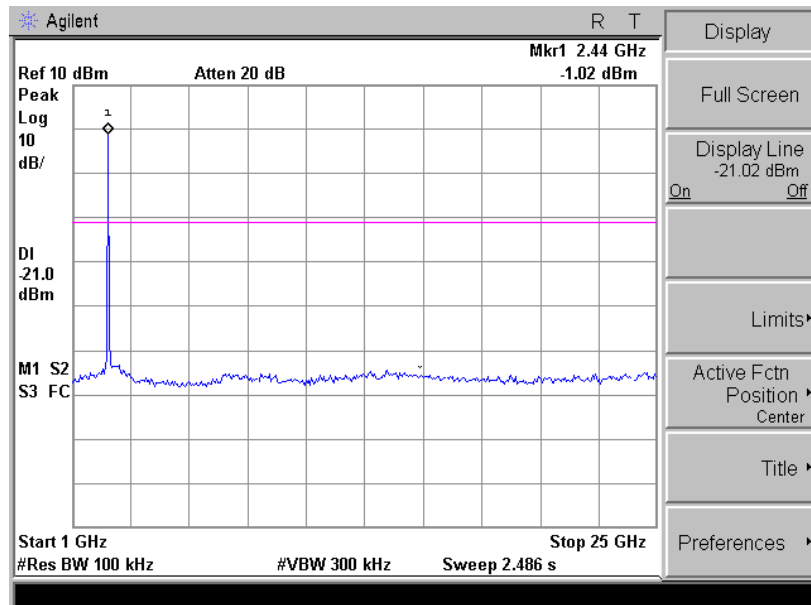
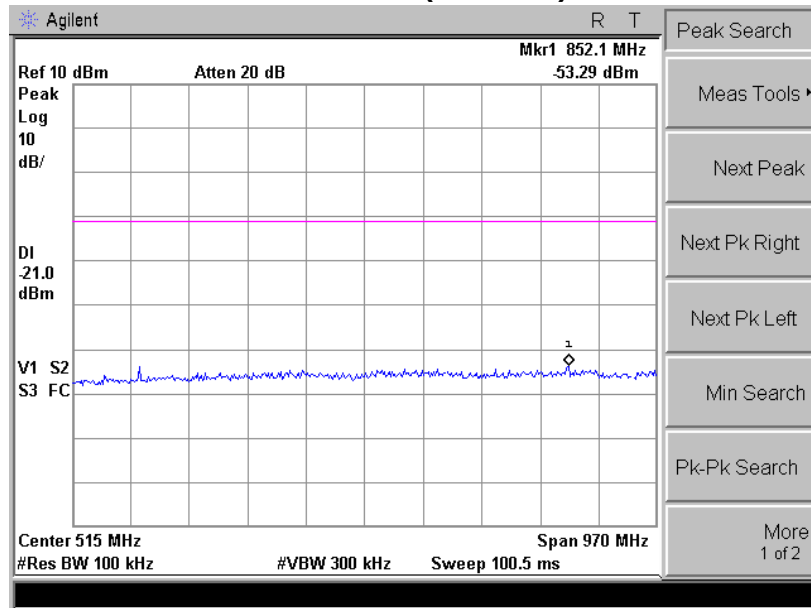

Channel 11 (2462MHz)

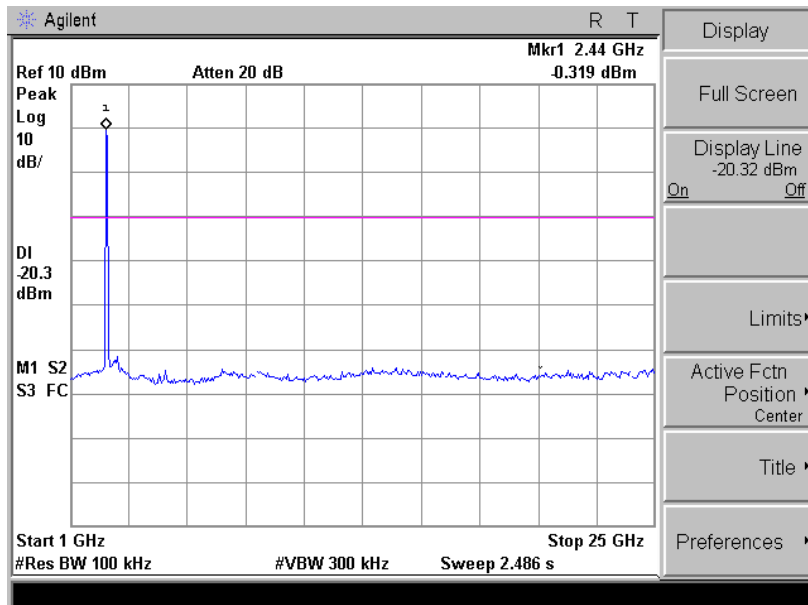
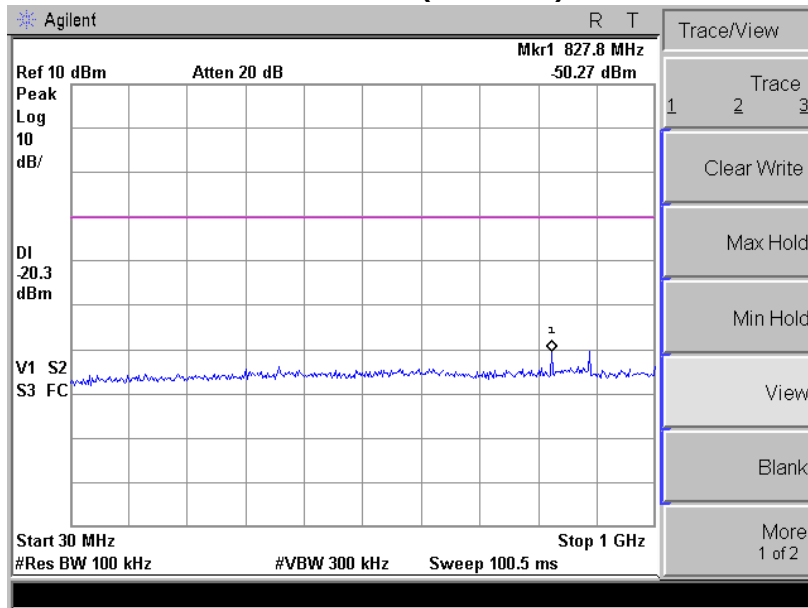

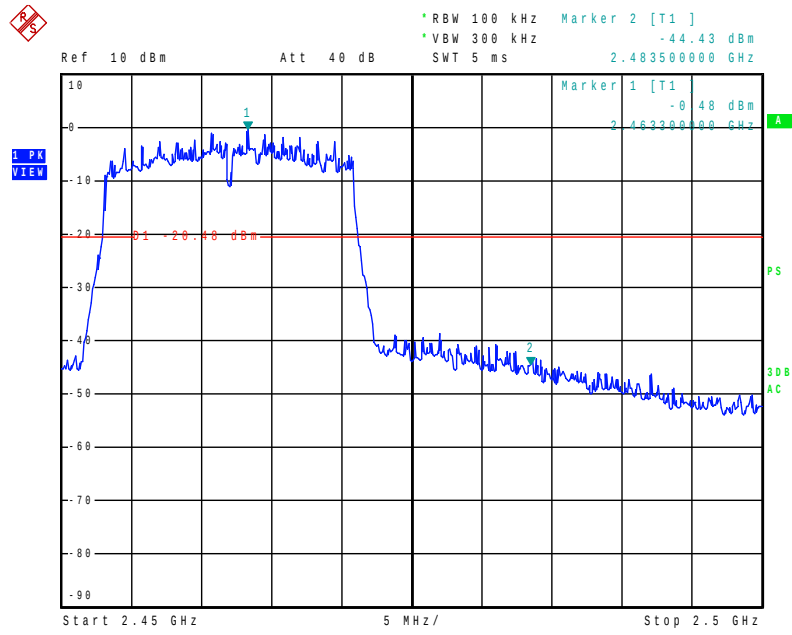

Date: 1.DEC.2015 11:44:47

4.8. Antenna Requirement

STANDARD APPLICABLE

For intentional device, according to FCC 47 CFR Section 15.203, an intentional radiator shall be designed to ensure that no antenna other than that furnished by the responsible party shall be used with the device.

And according to FCC 47 CFR Section 15.247 (c), if transmitting antennas of directional gain greater than 6dBi are used, the power shall be reduced by the amount in dB that the directional gain of the antenna exceeds 6dBi.

Refer to statement below for compliance.

The manufacturer may design the unit so that the user can replace a broken antenna, but the use of a standard antenna jack or electrical connector is prohibited. Further, this requirement does not apply to intentional radiators that must be professionally installed.

ANTENNA CONNECTED CONSTRUCTION

The directional gains of antenna used for transmitting is 2 dBi, and the antenna connector is designed with permanent attachment and no consideration of replacement. Please see EUT photo for details.

5. Test Setup Photos of the EUT



6. External and Internal Photos of the EUT

External Photos of EUT







Internal Photos of EUT

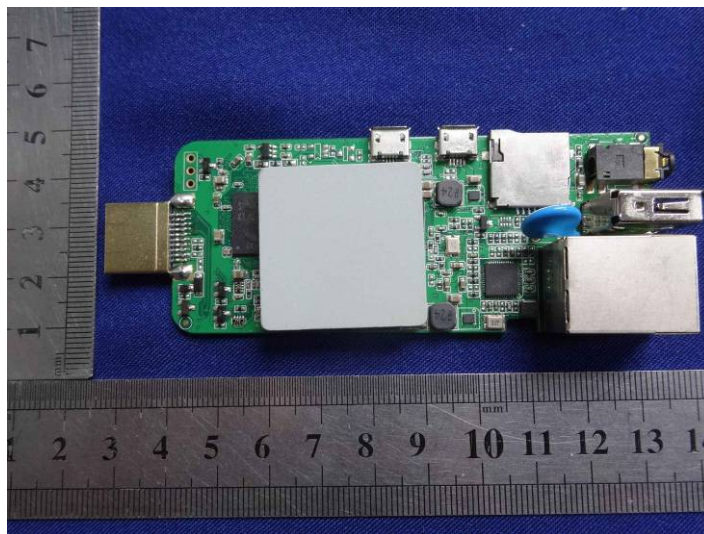
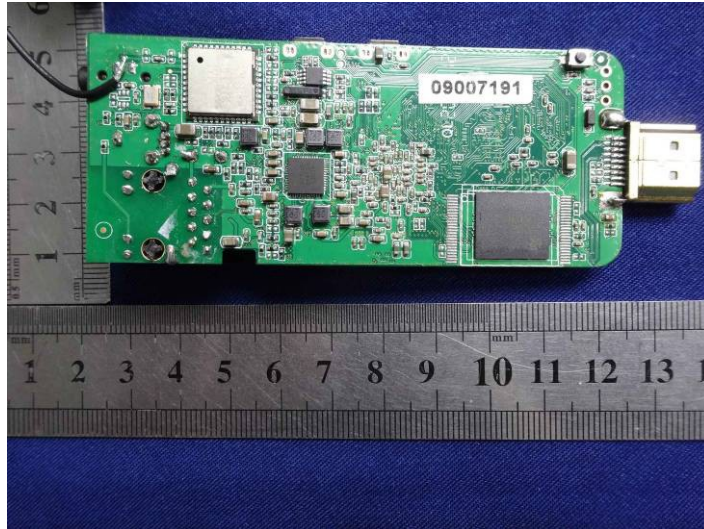



.....End of Report.....