

Veefil



Electric vehicle fast charger instruction manual

enquiries@tritium.com.au T: +61 (0)7 3129 4389

www.tritium.com

Veefil® is a registered trademark of Tritium Pty Ltd. © 2014 Tritium Pty Ltd



Contents

Important Safety Instructions and Specifications. Save these instructions.....	3
FCC Notice.....	5
Packaging, Handling & Receipt.....	6
Site Configuration & Fixing.....	7
Installation requirements & equipment.....	14
Unpacking & installation preparation.....	16
Fix to ground & feed power.....	18
Wire & Commission. 1. WORLDWIDE (excluding USA).....	23
Wire & Commission 2. USA only.....	24
Closing checklist.....	25
Operating Instructions.....	27
Model TRI93-50-02	
DC and AC charging specifications.....	31
Site configuration & fixing.....	32
Unpacking & installation preparation.....	35
Fix to ground and feed power	36
Operating Instructions.....	39
Maintenance Instructions - all models.....	40

Important Safety Instructions and Specifications. Save these instructions

This manual contains important instructions for the Veefil® electric vehicle fast charger models;
TRI93-50-01, 50kW dual DC (worldwide excluding USA).
TRI93-50-01-US, 50kW dual DC (USA market only).
TRI93-50-02, 50kW DC+AC (worldwide excluding USA).

Model TRI93-50-02 specifications, site configuration and installation procedures are described in pages 30 to 38.

These instructions must be followed during installation, operation and maintenance of the unit.



CAUTION

The Veefil fast charger must be installed and serviced only by qualified electrical personnel.

To achieve EMC compliance, the chassis of the Veefil must be bonded to Earth locally at the charger.

Grounding Instructions

This unit is to be connected to a grounded, metal, permanent wiring system; and an equipment-grounding conductor is to be run with circuit conductors and connected to equipment-grounding terminal or lead on battery charger. Connections to the battery charger shall comply with all local codes and ordinances.

All pertinent national, regional and local safety laws and regulations must be observed when installing and commissioning the Veefil fast charger.

Identifying Symbols



CAUTION



RISK OF ELECTRIC SHOCK



Equipment Grounding Conductor Symbol



Phase Symbol



Alternating Current Supply Symbol

Wiring Size

Worldwide (excluding USA)

3ø: 25mm²
Use 90°C Copper Wire

Take care to observe local regulations regarding wiring different circuits in the same conduit, including the ethernet link if used. In general all conductors occupying the same conduit shall have an insulation rating equal to at least the maximum circuit voltage applied to any conductor within the conduit.

Important Safety Instructions and Specifications. Save these instructions

USA only:

3 ϕ : 4AWG
Use 90°C Copper Wire
Use 4 AWG insulated
grounding conductor

1 ϕ : 18AWG
Use 90°C Copper Wire

An insulated grounding conductor that is identical in size, insulation material and thickness to the grounded and ungrounded branch-circuit supply conductors except that it is green with or without one or more yellow stripes is to be installed as part of the branch circuit that supplies the unit or system. This grounding conductor is to be grounded to earth at the service equipment or, when supplied by a separately derived system, at the supply transformer.

Input:

Worldwide (excluding USA):

3 ϕ WYE CONNECTED
230/400V, 240/415V \pm 10%
50Hz \sim
55kW

USA Only:

3 ϕ WYE CONNECTED
277/480V \pm 10%
60Hz \sim
52kW

1 ϕ , 120V
60Hz \sim
250W

The Veefil must be connected to a circuit provided with appropriate branch circuit over-current protection in accordance with the National Electrical Code, ANSI/NFPA 70.

Tightening Torque:

Wiring terminals:
4.0 Nm/35 lb-in

Service Hatch:
1.0 Nm/8.75 lb-in

Operating Temperature:

-20° to 50°C / -4° to 131°F
(-35°/-31°F optional)

Maximum Ambient Temperature:

55°C /131°F

Weather Rating:

IP65 Electronics Enclosure
NEMA Type 3R

FCC Notice

Information to the user (FCC Part 15.105)

Class A product:

NOTE:

This equipment has been tested and found to comply with the limits for a Class A digital device, pursuant to part 15 of the FCC rules. These limits are designed to provide reasonable protection against harmful interference when the equipment is operated in a commercial environment. This equipment generates, uses and can radiate radio frequency energy and, if not installed and used in accordance with the instruction manual, may cause harmful interference to radio communications. Operation of this equipment in a residential area is likely to cause harmful interference in which case the user will be required to correct the interference at his own expense.

Modification warning (FCC Part 15.21)

In addition the user's manual or instruction manual shall caution the user that changes or modifications not expressly approved by the party responsible for compliance could void the user's authority to operate the equipment (see below for example)

Warning: Any changes or modifications not expressly approved by (Tritium Pty Ltd) could void the user's authority to operate this equipment

Packaging, Handling & Receipt

Please note:

Read these instructions carefully to become familiar with Veefil packaging and handling procedures prior to unpacking and installation.

In all cases, the Veefil is to be transported to the installation site in its original packaging and only unpacked at the installation site.

Installation, commissioning and servicing of the Veefil should only be carried out by qualified personnel.

Materials:

The Veefil is transported in a reinforced cardboard crate.
Please respect the environment and recycle/reuse the materials.

Storage:

Store in the original packaging in a horizontal position.
Storage temperature:
-20 to 45°C / -4 to 113°F.

Handling:

Only lift the Veefil packaging in its horizontal orientation using a forklift, pallet jack or with lifting straps and engine hoist, forklift or crane. Check the weight on the delivery documents and ensure the lifting apparatus used is compatible.

Receipt:

Check that the crate packaging is in good condition and that the Veefil is not damaged.

If there are any problems noted, make a formal complaint to the carrier and notify your supplier.

Packed crate weight for models:

TRI93-50-01, 50kW dual DC
TRI93-50-01-US, 50kW dual DC
200kg/440lb

TRI93-50-02, 50kW DC+AC
(worldwide excluding USA)
230kg/507lb

Crate size for models:

TRI93-50-01, 50kW dual DC
TRI93-50-01-US, 50kW dual DC
850 x 2150 x 450mm
33.5 x 84.5 x 18 inches

TRI93-50-02, 50kW DC+AC
(worldwide excluding USA)
850 x 2140 x 630mm
33.5 x 84.5 x 25 inches

Site Configuration & Fixing

Site Survey:

The installation site must be surveyed by qualified engineer/s to determine the correct ground preparation for the size and weight of the Veefil, in accordance with local regulations.

The Veefil is best installed following the recommended site configuration requirements.

Ground Fixing:

The Veefil is to be fixed to the ground through the baseplate fixing holes with 4 x M16 or 5/8 inch fasteners (not supplied). The fasteners should fix the Veefil securely to the foundation through the baseplate and protrude 30-40mm/1.2-1.6 inch maximum from the foundation surface, in accordance with the dimensions and fixing points shown in:

Figure1: Base plate dimensions.

See Figure 6: Base template Walls for installation against or near walls or other obstacles.

Foundation Requirements:

The foundation must be flat, even, and the appropriate density for the weight of the Veefil.

Check the flatness and level of the foundation and level of the Veefil baseplate prior to fixing.

Appropriate spacers may be used under the Veefil baseplate to level the foundation.

If spacers are used, gaps are best filled, taking care not to damage the baseplate surface and edge.

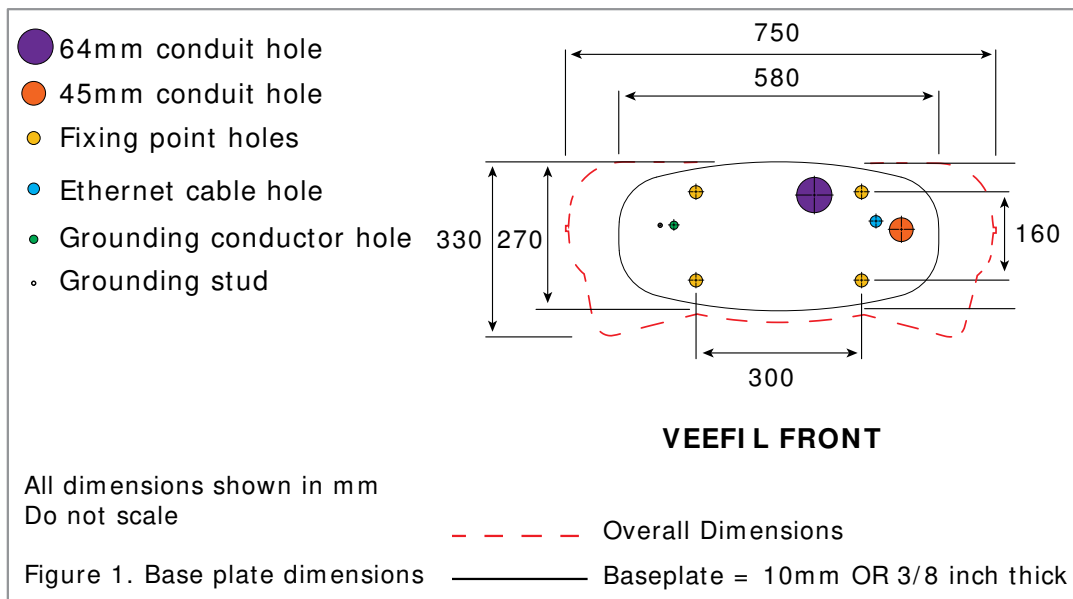

Site Configuration & Fixing

Electrical requirements:

Supply current:

Worldwide (excluding USA): 80A~
USA only: 63A~

Conduit fittings:

Worldwide (Excluding USA):

Use 40mm flexible conduit, or Flexa system:

Flexa PN 0237.202.036 conduit
Flexa PN 5020.037.250 conduit fitting
Flexa PN 0333.000.040 sealing washer
Flexa PN 0561.000.040 locking ring

USA Only:

Flexa PN 0237.202.036 conduit
Flexa PN 5020.056.207 conduit fitting
Flexa PN 0331.001.008 sealing washer
Flexa PN 0531.000.006 locking ring or 1 1/4" metal locking ring

Communications:

3G network capability or Ethernet.

Ethernet cable (if required)

Worldwide (Excluding USA):
Use 20mm flexible conduit.

USA Only:

Use ENMT Schedule 40 PVC 3/4in conduit.

Power supply preparation:

The Veefil is designed to accommodate power cabling in two different scenarios; through an underground conduit, or with conduit above the ground. Refer to the installation instruction for full details on installation and commissioning.

Underground power in conduit:

When power cabling is provided from an underground foundation it enters the Veefil through the baseplate conduit hole as shown in Figure 1 and Figure 2.

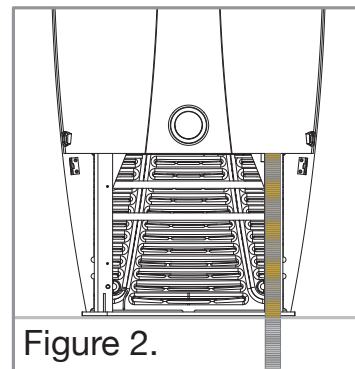

When preparing the foundation, allow approximately 1 metre/ 3 feet of conduit and wiring from the foundation surface as shown in Figure 3.

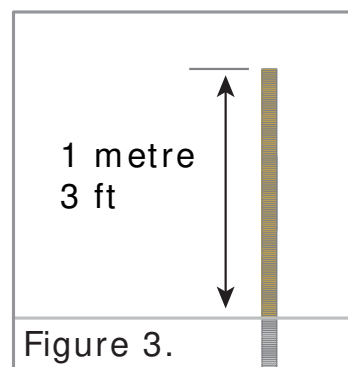

Above ground power in conduit:

Site Configuration & Fixing

When power cabling is supplied above the ground or down a wall it will enter the Veefil via the back radiator panel on the left hand side as shown in Figure 4.

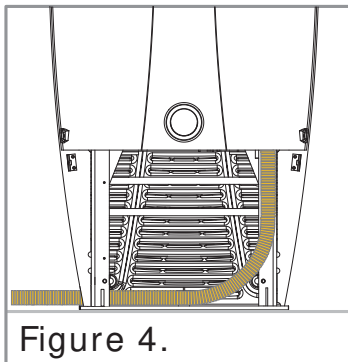
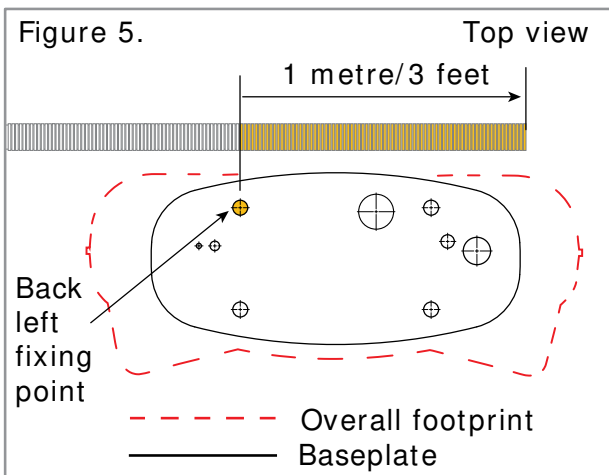

Figure 4.

Leave at least 1 metre/3 feet of conduit and wiring from the back left fixing point, for installation as shown in Figure 5. Prior to installation the conduit and wiring will require trimming.



Site Configuration & Fixing

Veefil charging cable range:

The standard Veefil cable reach is approximately 2.0 metres/6.5 feet as shown in these site layouts.

Customised lengths are also available. Contact your supplier should your requirements differ.

If longer length cables are used please ensure the cable is kept tidy and close to the Veefil sides at all times.

Single or back to back carparking bays:

To service one car bay or back-to-back car parking bays, 500mm/19.6 inches of space is recommended between the car and the Veefil front and back for ease of use.

Wheel stops installed at 1200mm/4 feet from the centre front and back of the Veefil can achieve this.

If the Veefil is to be installed with its back or sides against or near a wall or other obstacle, use the minimum distances shown in Figure 8.

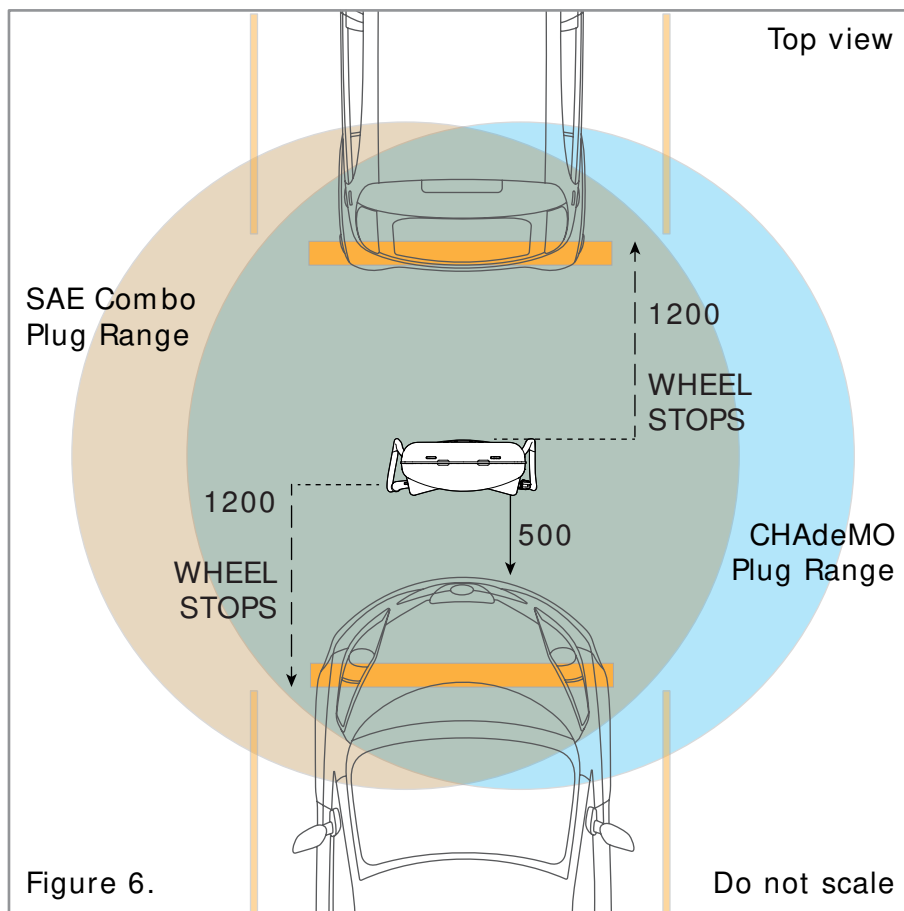

Site Configuration & Fixing

Multiple adjacent carparking bays:

To service two adjacent car parking bays, it is recommended to install the Veefil inbetween the bays facing directly out.

Wheel stops a minimum of 1100mm/3.6 feet from the center front of the baseplate are recommended to ensure enough space between the cars and the Veefil.

If the Veefil is to be installed with it's back or sides against or near a wall or other obstacle, use the minimum distances shown in Figure 8.

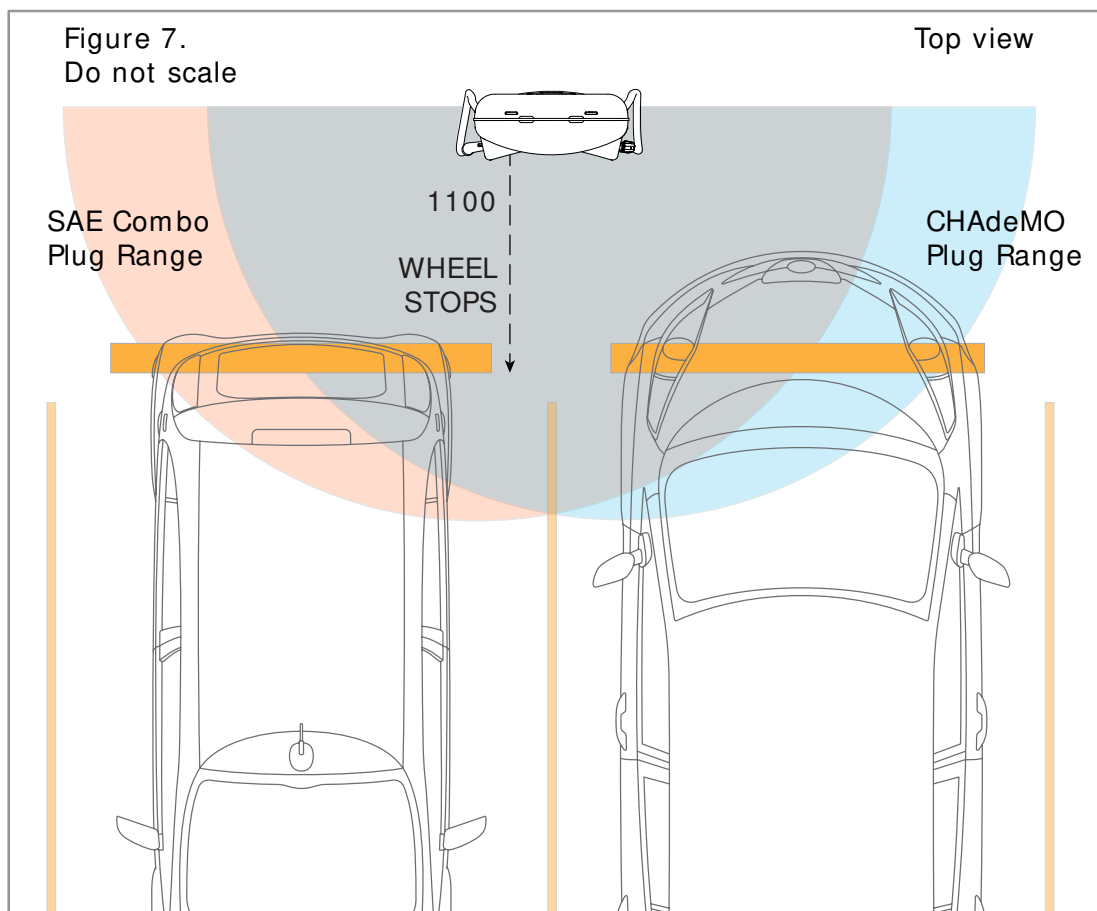

Site Configuration & Fixing

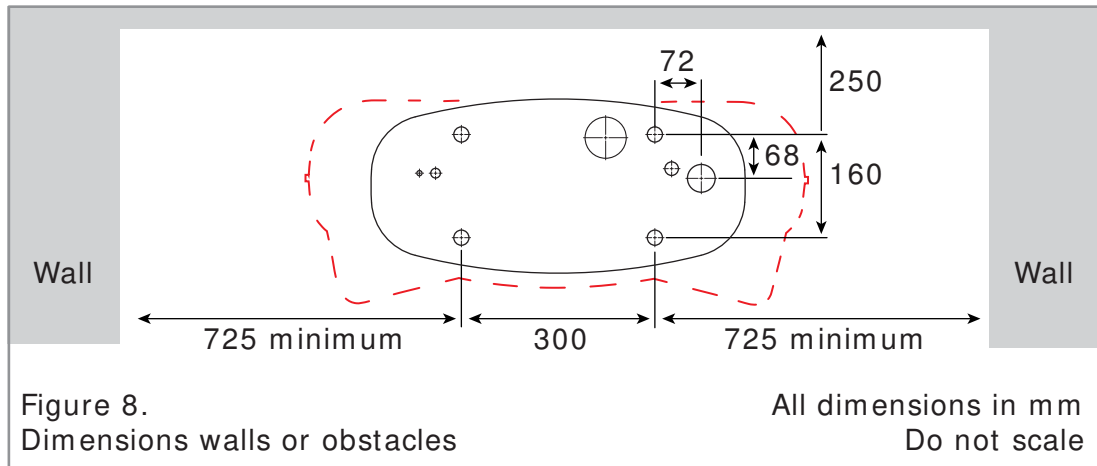

Contact Tritium for installation advice if your minimum measurements are smaller than shown in Figure 8.

Site Configuration & Fixing

Site configuration back to back units:

When being installed back to back, a minimum distance of 300mm/12 inches between the Veefils is recommended. To ensure this minimum distance is observed use the dimensions for foundation positioning in Figure 9.

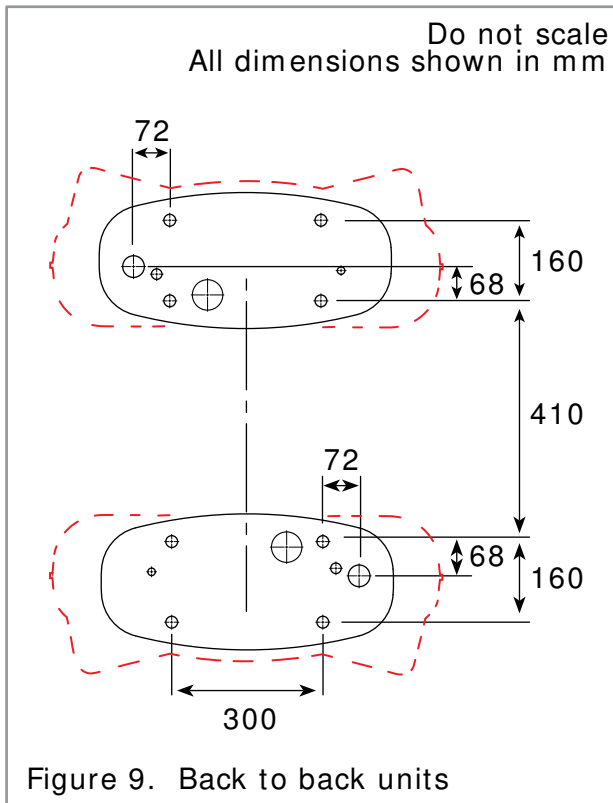

Site configuration servicing:

A additional space of 700mm/27.5 inches from the center front of the baseplate is required to open the front panel for servicing, as shown in Figure 10.

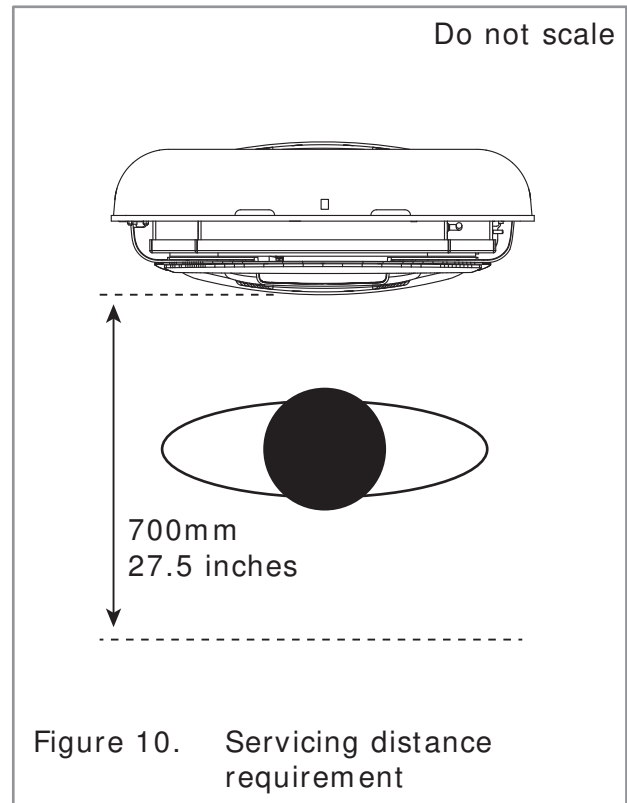

Installation requirements & equipment



These instructions provide a systematic guide for installing and commissioning the Veefil.

The Veefil must be installed and serviced by qualified electrical personnel.

All pertinent national, regional & local safety regulations must be observed when installing and commissioning the Veefil.

The Veefil has an IP65 and NEMA Type 3R electronics enclosure rating, however, as it must be opened for installation, this is best done in dry weather or under cover to avoid moisture or debris ingress.

Installation shall not be done in a commercial garage (repair facility) or closer than 6 meters/20ft of an outdoor motor fuel dispensing device.

The Veefil must be properly installed, assembled and commissioned according to these instructions before it is used.

Prior to Installation contact your supplier to organise commissioning information.

Supplied with Veefil:

Blanking plugs are fitted for transport and storage.

Metric conduit fittings and seals are supplied for installation (except USA).

Ferrite rings. See Wire and Commission section for instruction.

Required equipment:

Lifting apparatus. The charger weighs 170kg/374 lbs, ensure lifting apparatus is sufficiently rated.

For height restricted areas alternative lifting methods are available. Contact your supplier for more information.

Worldwide (excluding USA):

40mm standard flexible conduit or Flexa 40mm conduit - see pg 7.

USA only:

Flexa system - see pg 7.

Installation requirements & equipment

5mm Pin Hex Bit & tool

Socket set & Ratchet or adjustable
spanner

Jointing Cement

If Ethernet cable is required use:

Worldwide (excluding USA):
20mm flexible conduit

USA only:
Flexa 3/4" conduit.

DOCUMENT KEY:



Items shown in orange are parts that
require action for that step.

Unpacking & installation preparation

1. Open Crate

Move the crate as close to the prepared installation site as possible. Ensure there is enough room to manoeuvre the lifting apparatus.

Remove/slide out all crate tubes to disassemble the cardboard crate.

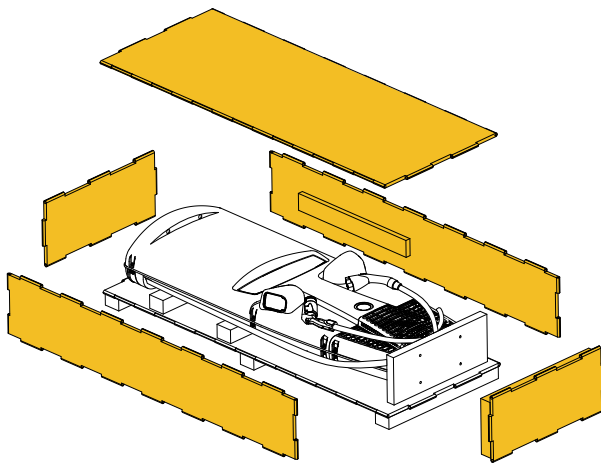

2. Lift Veefil to Vertical

Securely attach the lifting straps at the top of Veefil to the lifting apparatus and gently raise to a standing position on the shipping baseplate.

NOTE: The Veefil is 2050mm/6.72ft tall on the shipping baseplate.

■ Do not use the plug holders to assist lifting the charger at any stage.

Once upright remove all wrapping.

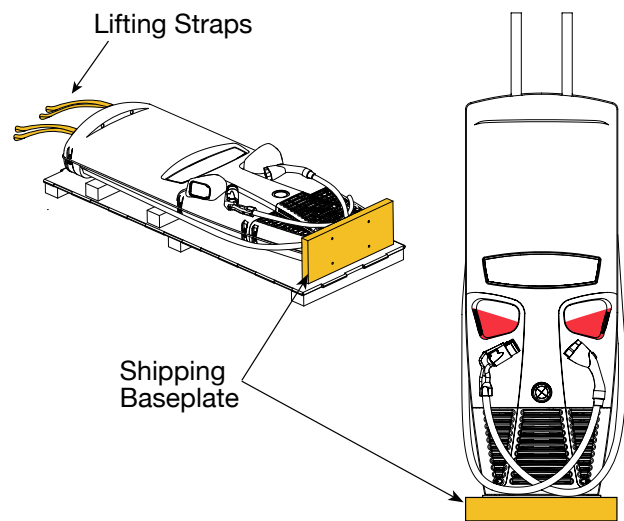

Unpacking & installation preparation

3. Remove front and rear radiator panels

Unscrew the 4x security screws and remove them and the washers from both radiator panels using the 5mm Pin Hex bit. Pull the radiator panels away from the metalwork frame to remove.

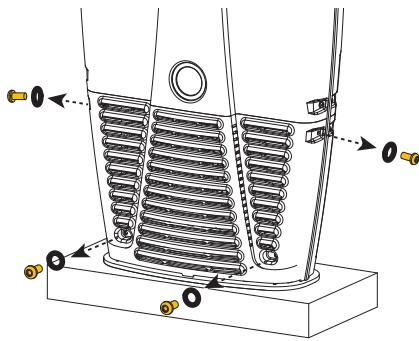

4. Remove shipping bolts

Unscrew the 4x bolts from the shipping base to disengage.

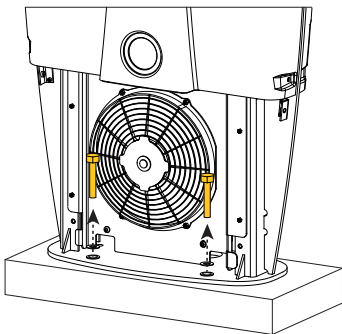

If your installation supplies power from above the ground, proceed to pg 17.

If your installation supplies power from an underground foundation remove the radiator.

5. Remove radiator

Unscrew the 4x nuts to remove the radiator. Slide the radiator off the fasteners, and sit the radiator on the base plate.

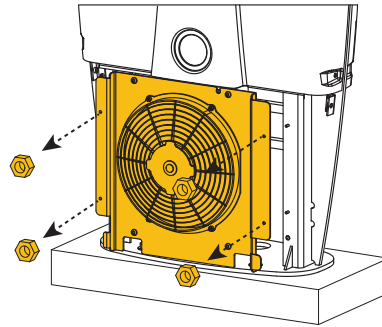

Reach behind and unclip the four way connector and cooling hoses to disengage.

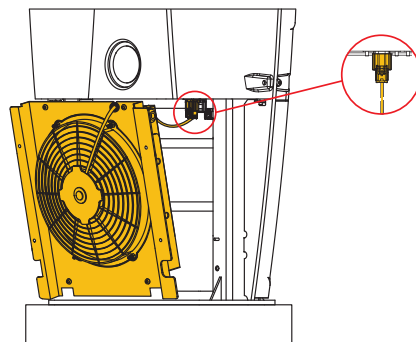

The four way connector is the left hand plug attached to the underside of the unit. Squeeze front clip and pull down to release.

Unclip the 2x quick release cooling hoses which are behind the radiator to completely disengage the radiator from the unit. Store in a safe place ensuring no damage to cooling hoses for later re-assembly.

Fix to ground & feed power

1. Secure to foundation

Lift the Veefil and place onto the prepared foundation and secure. If power cabling in conduit is supplied from underground, feed through the baseplate conduit hole.

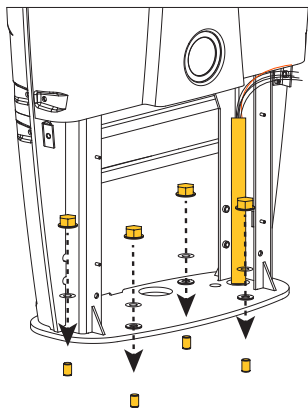

2. Remove fasteners from front panel

Remove the 6x security screws and washers from the front panel.

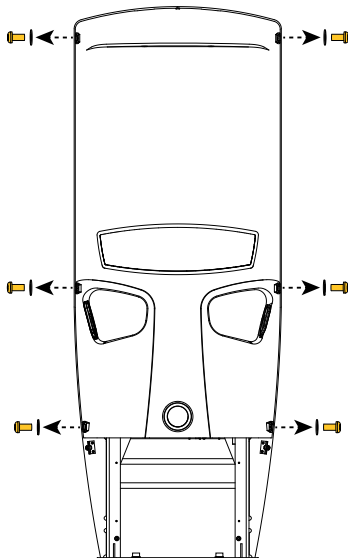

3. Place front panel on ground

The front panel is attached to the enclosure with wiring and an earthing strap on the front left hand side.

Lift the front panel up to release from the top hook and gently lower to the ground in front of the Veefil.

In calm conditions it may be possible to keep the front panel connected during commissioning. If this is possible, go to page 18, item 5.

If in doubt, disconnect the front panel (see pg 18, item 4) and store in a safe place until the unit is ready to close for use.

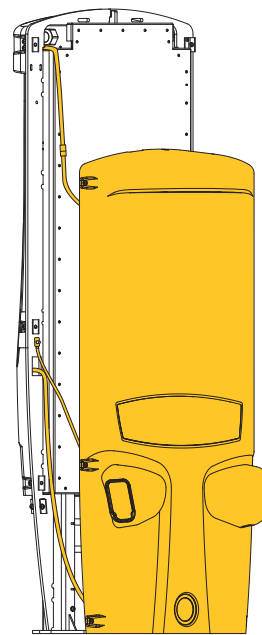

Fix to ground & feed power

4. Disconnect front panel

There are three points to disconnect:

1. Wiring to the top rear panel.
Squeeze the connector to disconnect.
2. Earthing strap.
Unscrew the bolt on the metalwork.
Remove the bolt, earthing strap and washers.
3. Connector 'B' on the HMI panel.
Connector 'B' detaches by squeezing the connector front and rear with your fingers and pulling down.

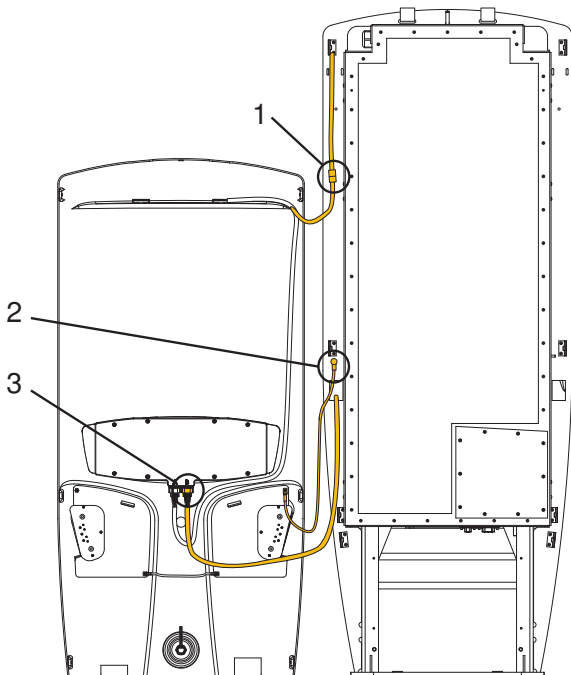

5. Remove service covers

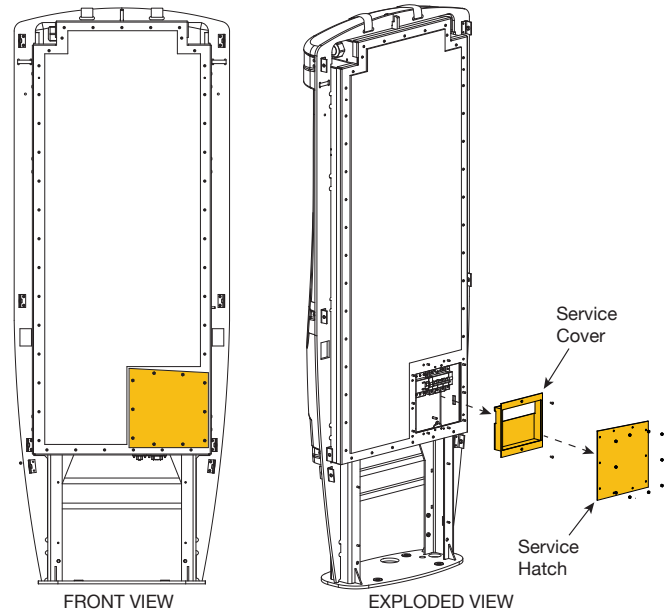

Remove the service hatch and cover to access the internal enclosure to prepare the Veefil for wiring.

The Service Hatch has an attached gasket. Ensure this is carefully stored to avoid damage or accumulation of debris.

The wiring diagram is on the inside of the Service Hatch and also in this manual.

Fix to ground and feed power

6a. Fit underground conduit & feed in power

If your installation has above ground conduit, see 6b.

Remove the blanking plug and replace with supplied conduit fitting and seal. Trim the conduit to fit into the conduit fitting and feed a minimum of 300mm/12 inches of wiring through into the interior ready for commissioning. Seal the conduit into the conduit fitting with Jointing Cement so that no water or debris can enter.

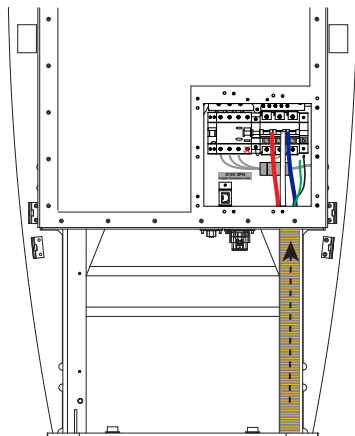

6b. Fit above ground conduit & feed in power

Remove the blanking plug and replace with supplied conduit fitting and seal.

Feed the conduit from the rear right of the unit and bend up into the conduit fitting. Remove the radiator if required. (see Unpacking and Installation).

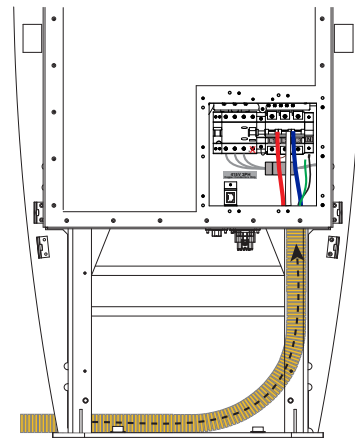

Trim the conduit to fit into the conduit fitting and feed a minimum of 300mm/12 inches of wiring through into the interior ready for commissioning. Seal the conduit into the conduit fitting with Jointing Cement so that no water or debris can enter.

Use the slots in the rear left channel to cable tie the conduit in place if necessary.

Fix to ground and feed power

7. Trim the rear radiator panel

The rear radiator panel provides the exit point for the conduit from the Veefil.

Cut the three tabs on the lower right hand of the radiator panel to remove the material to open the conduit exit point.

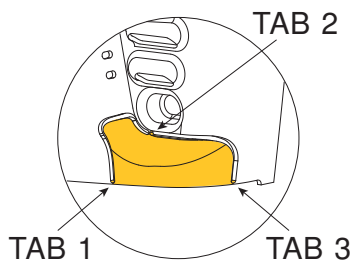
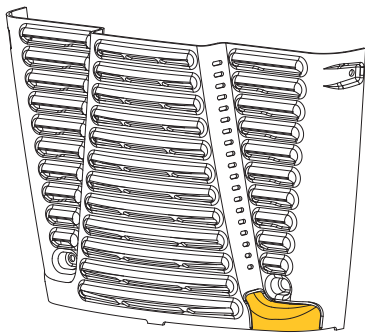

8. Fit the rear radiator panel

Replace the rear radiator panel ensuring the conduit is fitted securely within this exit area.

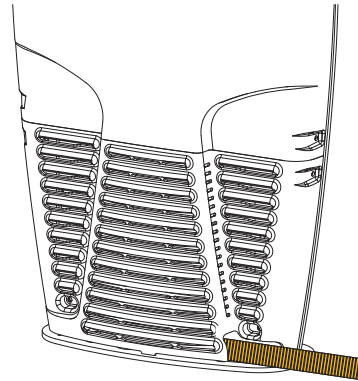

If there are more than two conduit hoses (possible Ethernet cable in conduit) place the largest at the base with the smaller feeding above.

Wire & Commission Overview



CAUTION

Wiring and commissioning the charger is to be done by qualified electrical personnel only.

Connect as shown in one of the following diagrams;

1. Worldwide (excluding USA)
2. USA only.

The wiring diagram is also available on the inside of the Service Hatch.

In all cases:

Use Copper Conductors only.

Check that the wiring is sitting behind the lower face of the switch gear so they will not interfere with the service cover.

When completed, switch on the breaker and check the interface panel on the front door is cycling through the icons. Each icon will be lit in turn on the interface panel.

Contact your supplier to run through the diagnostic testing to commission the unit.

Wire & Commission

1. WORLDWIDE (excluding USA)

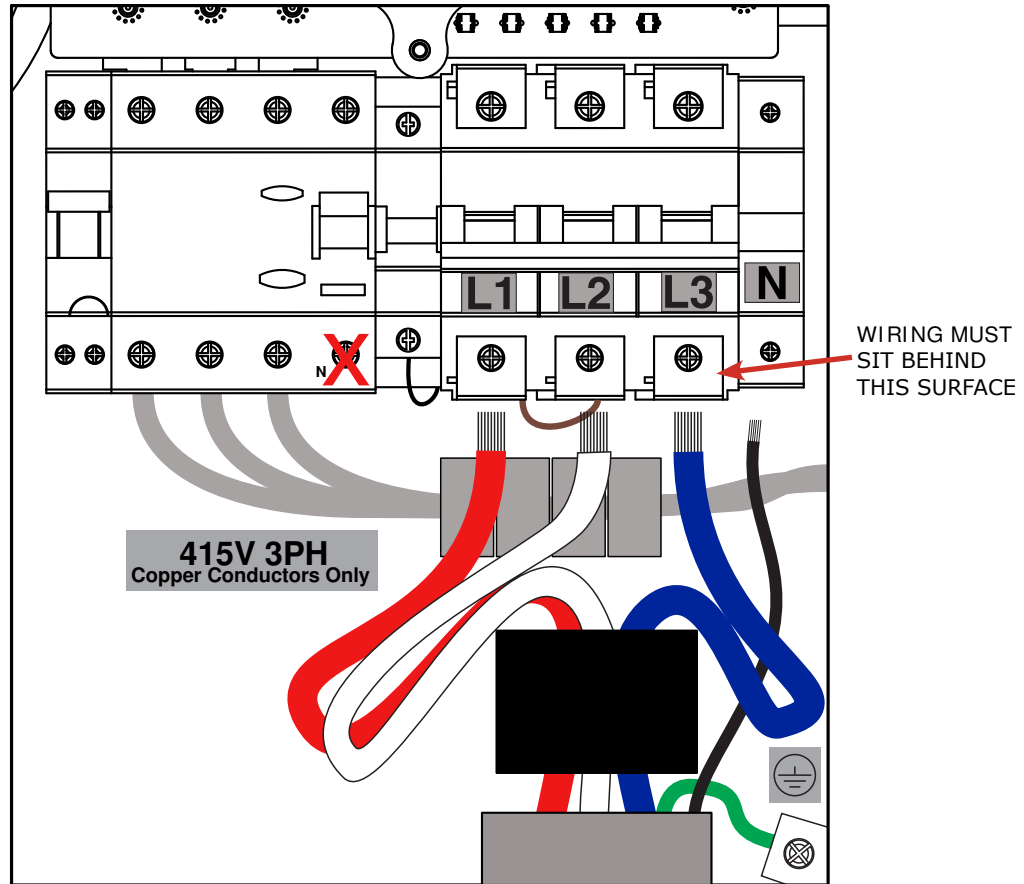

WIRING DIAGRAM

Through grey ferrite ring:
All wiring

Through black ferrite ring only:

Red = L1
White = L2
Blue = L3

Thread the wiring as shown through the supplied grey and black ferrite rings.

All wires go through the first grey ferrite ring.

Red, white and blue wiring goes through the black ferrite ring only.

Bend the wires to the side of the ferrite rings and up into the connection points ensuring they sit behind the lower surface of the switch gear to avoid interference with the service cover.

NOTE: Wire Neutral into the far right Neutral Terminator.

Wire & Commission

2. USA only

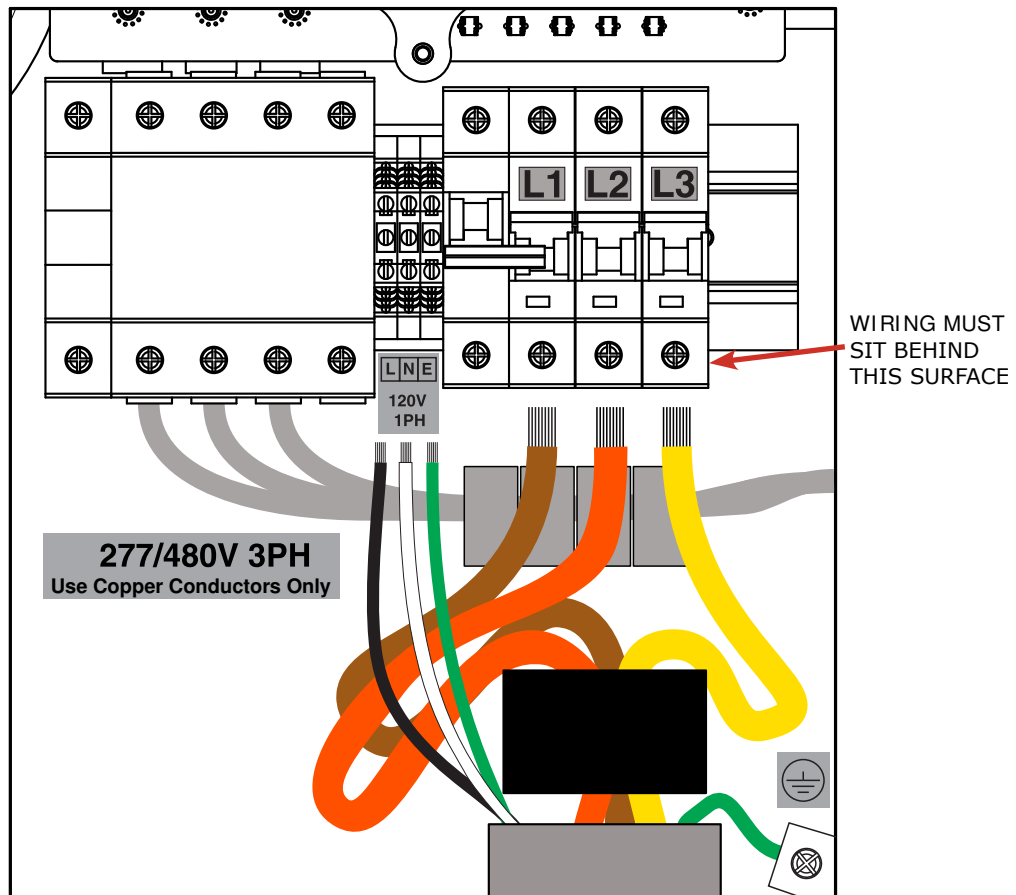

WIRING DIAGRAM

Through grey ferrite ring:
All wiring

Through black ferrite ring only:
Brown = L1
Orange = L2
Yellow = L3

Trim the wires leaving a minimum of 300mm/12 inches exposed and thread them as shown through the supplied grey and black ferrite rings.

All wires go through the first grey ferrite ring.

Brown, orange and yellow wiring goes through the black ferrite ring only.

Bend the wires to the side of the ferrite rings and up into the connection points. Check that the wiring is sitting behind the lower face of the switch gear so they will not interfere with the service cover.

Closing checklist

Once the charger has been commissioned the unit requires re-assembly and closing prior to operation.

Follow these steps in order to ready the unit for operation.

1. Remove lifting straps

Carefully remove the lifting straps from the top slots in the metalwork.

2. Attach Service Cover

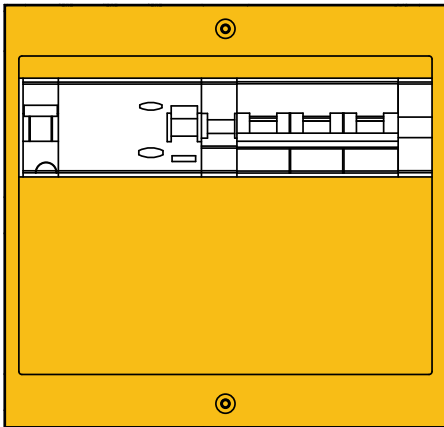

Place the Service Cover over the switch gear and ensure it sits flush with the metalwork panel prior to fastening. If it doesn't sit flush remove and ensure the wiring is sitting behind the lower face of the switch gear.

3. Attach Service Hatch over Service Cover

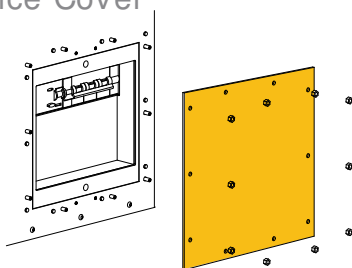

Check the gasket has not been damaged or soiled. If using a power drill to fasten the nuts ensure the correct torque setting of no greater than 1.0 Nm/8.75lb-in. If using hand tool, fasten until resistance felt. Do not over tighten.

4. Attach radiator

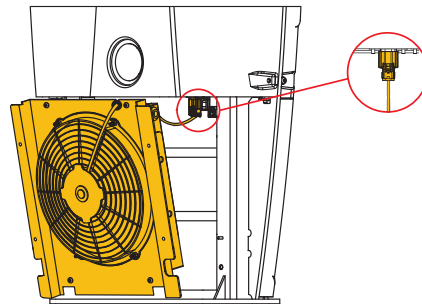

- Angle the radiator and rest on the base-plate.
- Re-connect the four way connector.
- Re-connect cooling hoses and ensure they are sitting out of the way to avoid pinching or obstructing the radiator.
- Locate the radiator onto the fixing studs.
- Fasten the radiator onto the studs.

5. Attach front/rear radiator panels

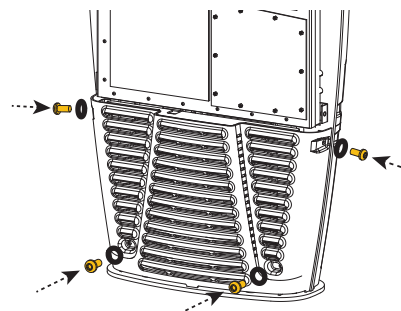

Sit the radiator panel on the base and against the metalwork, lining up the plastic holes with the bracket nuts.

Closing checklist

Fasten with black washers and security screws using the 5mm Pin Hex bit.
Do not over tighten.

6. Re-attach front panel wiring

If required, there are three points to re-connect:

1. Wiring to the top rear panel.
Plug in connector.
2. Earthing strap.
Replace the earthing strap fasteners in the following order: Star washer, lug attached to earthing strap, spring washer, and fasten to the metalwork with the bolt.
3. Connector 'B' on the HMI panel.
Plug in Connector 'B'.

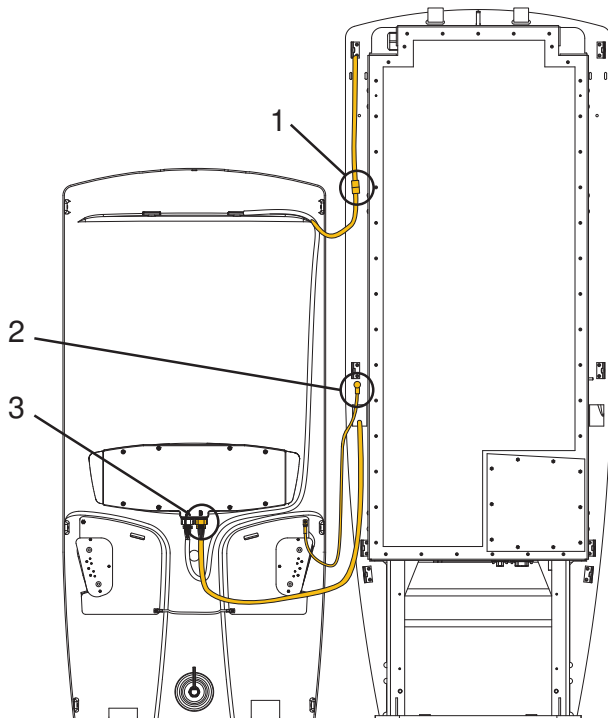

7. Attach front panel

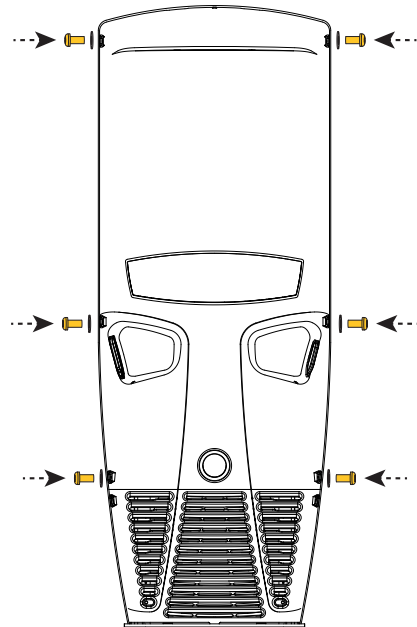

Gently place the front panel on the top hook ensuring the panel sits outside the fastening brackets. Sit on the radiator panel and check the top hook is engaged. It will hold in position. Secure with the nylon washers and security screws ensuring the plastic holes line up with the bracket nutserts. Do not over tighten.

The Veefil fast charger is now ready for operation.

Operating Instructions

Charging your car with the Veefil fast charger is safe, secure, and easy to do with industry standard plugs and a simple interface that guides you through the charging process.

The Veefil fast charger offers two different charging plugs, the CHAdeMO and the Combined Charging Standard (CCS) which cover all DC charging standards.



through card recognition, APP or SMS. Once activation authorisation has been recognised you have a certain timeframe to begin your charging session.

Using the interface panel

The top half of the panel has icons and buttons to prompt selection and control the charging session, and the lower half of the panel shows charging information. The interface will guide you through charging your vehicle by highlighting icons and buttons that are relevant at each stage of the charging session. At certain times you will also have audio feedback to assure you that certain functions have succeeded. Different models will have different graphics.

Depending on your Veefil model the minutes showing on the interface panel may be set by the car and are dependent on battery capacity and ambient temperature. Otherwise the minutes will display how long your car has been charging.

You will have ample time to make your selections, however if the charger has been idle for too long without making a selection it will return to being available for other users.

At any stage, returning the plug to the Veefil plug holder will end your charging session.

Activation security

Veefil has been designed to activate and secure your individual charging session

Operating Instructions

The Interface Panel

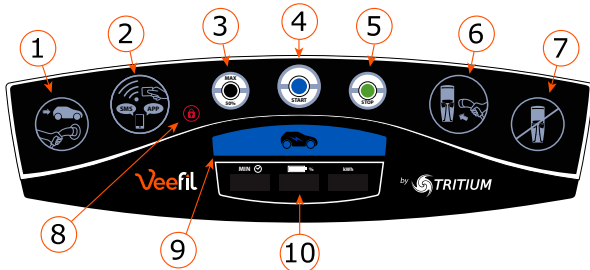

For the purpose of this manual the Veefil interface panel ACTIVATION icon includes APP and SMS. If these icons are not shown on your model, they are not available for use.

1. Connect Plug to Car

Icon flashes when the unit is available for use.

2. Activation

Swipe your card over this area or use your APP or SMS to activate the user interface, and to also unlock a charging session.

3. MAX or 50%

Toggle button to select a half or maximum charge amount.

4. Start

Push to start the charging session.

5. Stop

Push to stop the charging session.

6. Return Plug to Charger

Icon flashes to indicate that the charging session is complete and the plug should be returned to the plug holder.

7. Not in Service

Icon will light up when the charger is not

in service.

8. Locked symbol

Lit when a charging session is in progress and the interface panel is locked.

9. Charging indicator

Will glow when a charging session is in progress.

10. LED information displays

Displays minutes, battery percentage during charge, kilowatts delivered, fee charged.

Using the Veefil fast charger

1. Connect plug to car

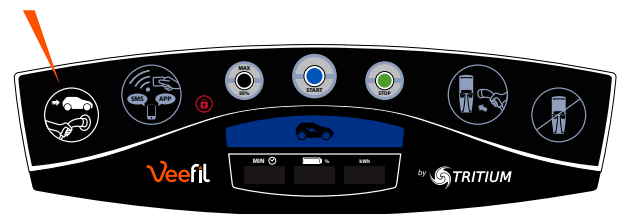

Ensure your car is switched off before proceeding.

On first approach the interface will highlight the CONNECT PLUG TO CAR icon. Select the correct charging plug for your car and remove from the plug holder. The icon will become a solid light when you have removed the plug.

Once the plug is correctly connected to your car you will hear a sound from Veefil and the plug will be locked to the car. The Veefil will then proceed to ACTIVATION.

Operating Instructions

2. Activation

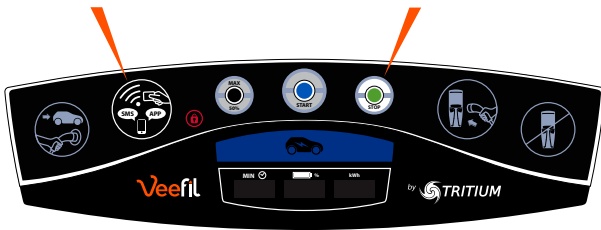

At this stage the ACTIVATION icon and the STOP button will be highlighted.

Touch your access card to the ACTIVATION icon for about 3 seconds or use your APP or SMS. You will hear a repeating 'pip' sound whilst authenticating and the icon will flash rapidly. Once authenticated, the CHARGE SELECTION will be enabled.

A charging fee may also be displayed at this stage if appropriate.

If authentication fails, a 3 second beep will be heard and the Veefil will proceed to RETURN PLUG TO CHARGER.

If no action is taken within three minutes the plug will unlock from the car. The STOP icon is highlighted during this time to allow you to unlock the plug if required. If STOP is pressed the Veefil will proceed to RETURN PLUG TO CHARGER.

3. Charge selection

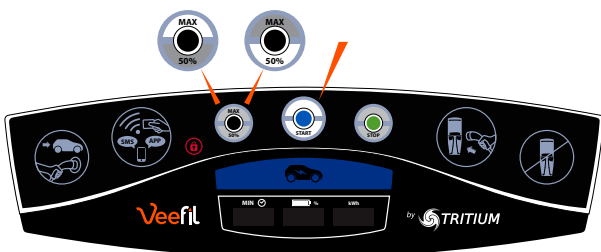

The Veefil is automatically set to MAX

which will charge your battery to 80% of its capacity. Pressing the MAX/HALF button changes this setting to HALF which sets the charge to 50% of battery capacity. Pushing this button toggles between MAX/HALF.

When you have made your selection press START to begin your charging session.

4. Charging



The CHARGING icon is highlighted and the numerical display will show active charging information. The STOP button will also be highlighted.

There is a 10 second window where pressing STOP will end the session. After this 10 second window, the interface will lock to protect your charging session and the LOCK and ACTIVATION icons will be highlighted.



Should you wish to interrupt your charging session, touch your card to the ACTIVATION icon to unlock the interface, and press STOP. The APP or SMS may also have this functionality.

Operating Instructions

Only the card that initiated the session is able to unlock the interface. The APP or SMS may also have this functionality.

If STOP is pressed at any stage, or if the charging session is complete, the charging plug and interface will unlock, and the interface will display proceed to RETURN PLUG TO CHARGER.

5. Return plug to charger

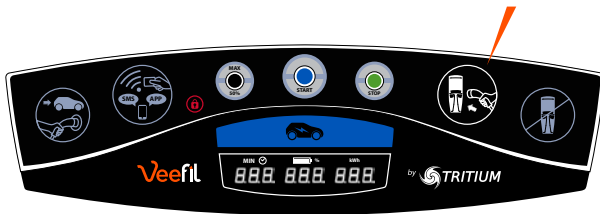

The charging session is complete and RETURN PLUG TO CHARGER is highlighted. The numerical display will show the completed charge session information. If appropriate, a fee may also be shown at this stage.

Once you have returned the plug to the Veefil your charge session information will be cleared and the interface will reset to CONNECT PLUG TO CAR to begin a new session.

If at any stage normal operation is interrupted you will see information on the LED's and RETURN PLUG TO CHARGER highlighted. Return the plug to the Veefil to reset.

6. Not in service

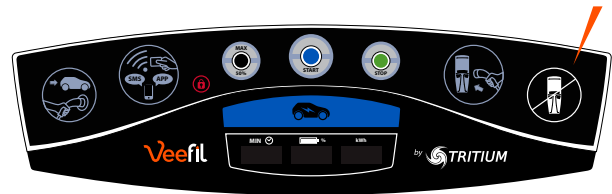

When the Veefil is unavailable for use the NOT IN SERVICE icon will be highlighted and the Veefil will not be operational.

Emergency stop



In case of emergency break the plastic and press the Emergency Stop Button to shut down and secure Veefil.

Model TRI93-50-02 - DC and AC charging Specifications

The following information is particular to model TRI93-50-02, 50kW DC+AC (worldwide excluding USA).

Wiring Size

If your Veefil is configured for simultaneous DC and AC charging then use the following:

3∅: 50mm²
Use 90°C Copper Wire

If your Veefil is configured for only one plug charging at any one time then use the following:

3∅: 25mm²
Use 90°C Copper Wire

Take care to observe local regulations regarding wiring different circuits in the same conduit, including the ethernet link if used. In general all conductors occupying the same conduit shall have an insulation rating equal to at least the maximum circuit voltage applied to any conductor within the conduit.

Required equipment

Lifting apparatus

Crate and charger weigh 230kg, the Veefil fast charger alone weighs 205kg. Ensure lifting apparatus is sufficiently rated.

Conduit

63mm flexible conduit

Supply current:

If your Veefil is configured for simultaneous DC and AC charging then use the following: 150A~

If your Veefil is configured for only one plug charging at any one time then use the following: 80A~

Smaller cable ratings can be used if the software is configured to limit the power draw.

Communications

3G network capability or Ethernet.

Ethernet cable (if required)

Use 20mm flexible conduit.

Site configuration & fixing

Model TRI93-50-02

Power supply preparation

The Veefil is designed to accommodate power cabling in two different scenarios; through an underground conduit, or with conduit above the ground.

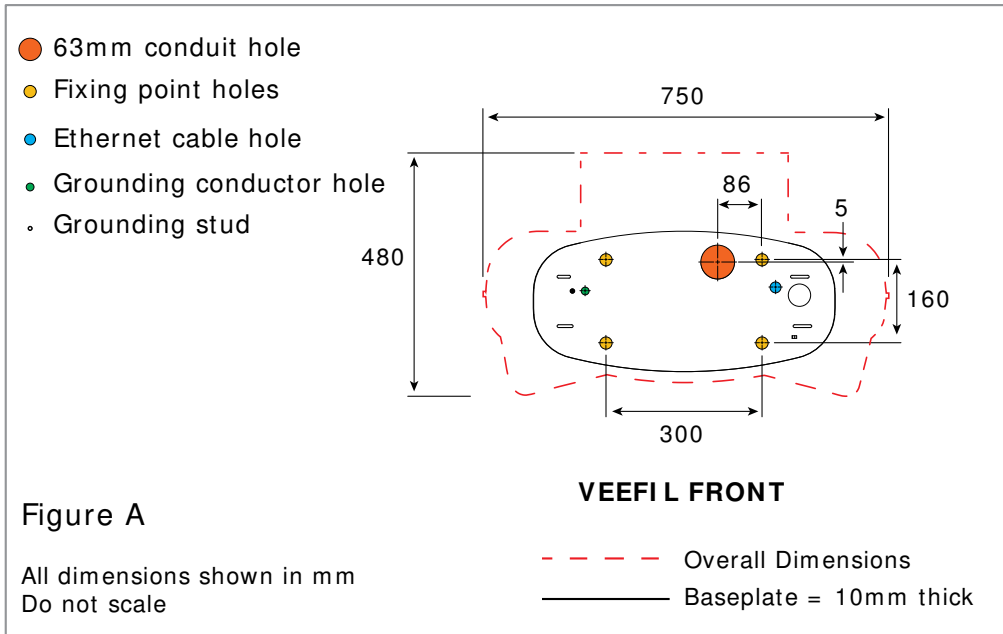

Underground power in conduit

When power cabling is provided from an underground foundation it enters the Veefil through the baseplate conduit hole as shown in Figure A and Figure B.

When preparing the foundation, allow approximately 1500mm of conduit and wiring from the foundation surface as shown in Figure C.

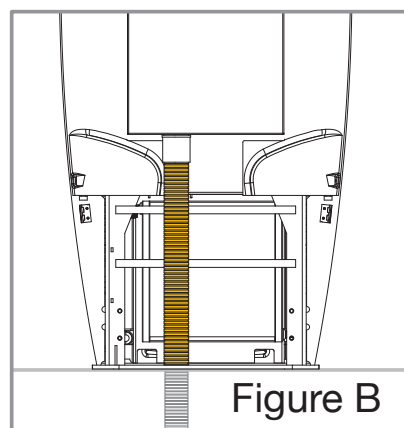

Site configuration & fixing

Model TRI93-50-02

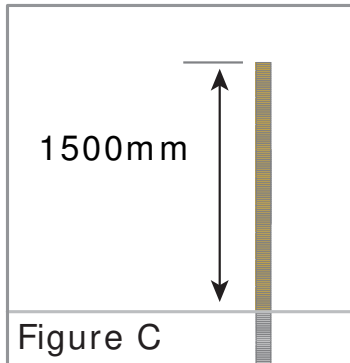

Above ground power in conduit:

When power cabling is supplied above the ground or down a wall it will enter the Veefil via the back radiator panel on the right hand side as shown in Figure D.

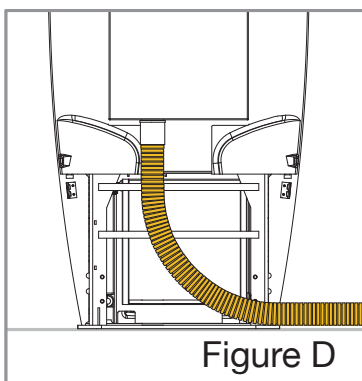

Leave at least 1500mm of conduit and wiring from the back left fixing point, for installation as shown in Figure E. Prior to installation the conduit and wiring will require trimming.

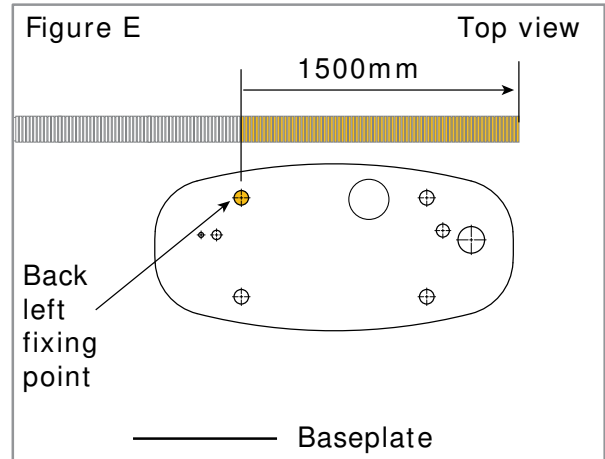

Site configuration & fixing

Model TRI93-50-02

Figure F outlines the minimum spacial requirements for installation, operation and servicing.

All measurements are taken from Veefil fixing holes.

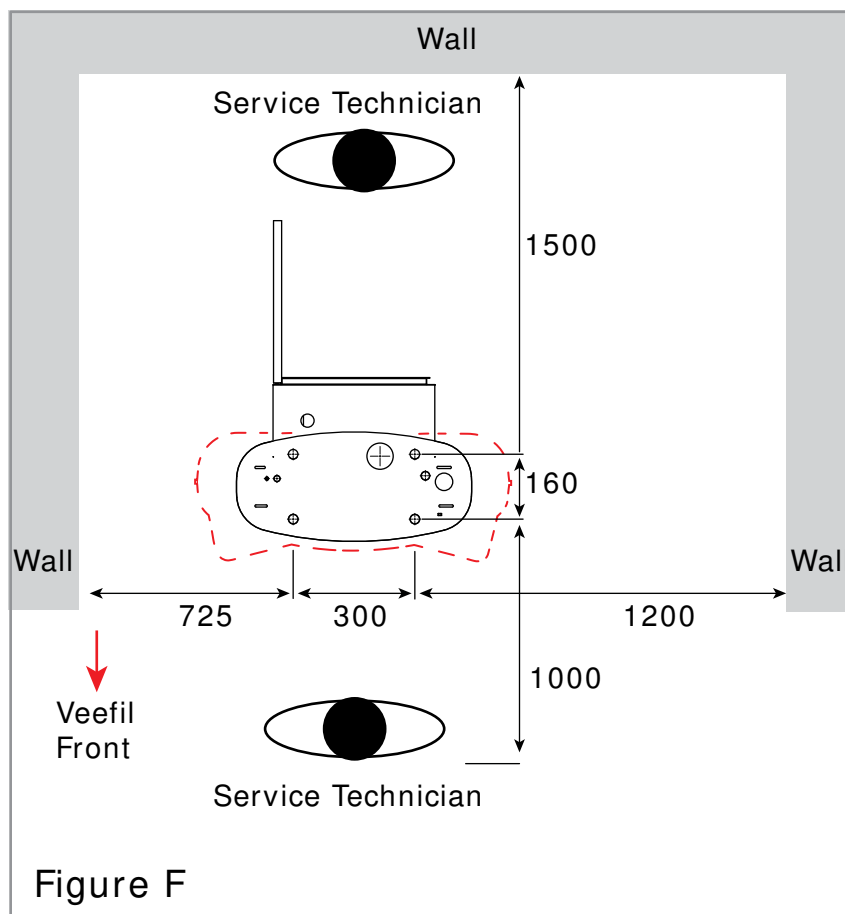

Unpacking & installation preparation

Model TRI93-50-02

Open the crate and raise the Veefil to standing as per all models.

1. Remove both radiator panels

Unscrew the 4x security screws and remove them and the washers from both radiator panels using the 5mm Pin Hex bit. Pull the radiator panels away from the metalwork frame to remove.

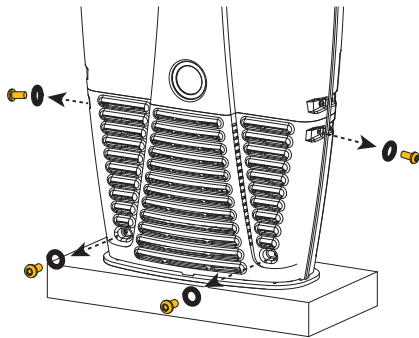

FRONT VIEW

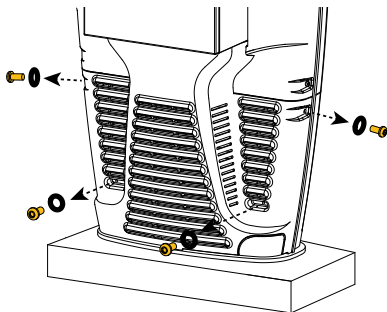

REAR VIEW

2. Remove shipping bolts

Unscrew the 4x bolts from the front and back of the shipping base to disengage.

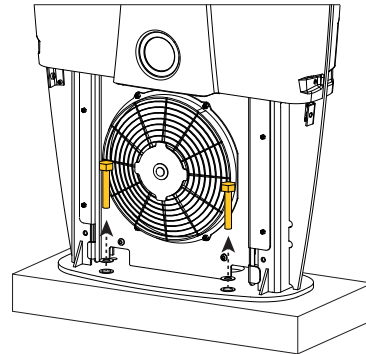

Fix to ground and feed power

Model TRI93-50-02

1. Secure to foundation

Lift the Veefil and place onto the prepared foundation and secure. If power cabling in conduit is supplied from underground, feed through the baseplate conduit hole.

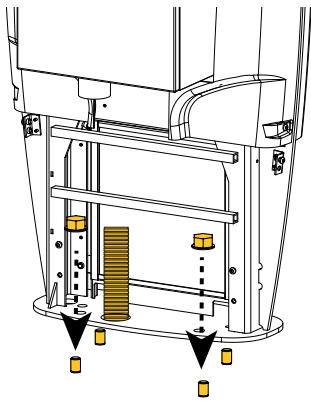

2b. Fit above ground conduit & feed in power

For above ground power supply, feed the conduit from the rear right of Veefil and curve the conduit as shown so it will fit into the cut out section of the rear radiator panel (see section 7).

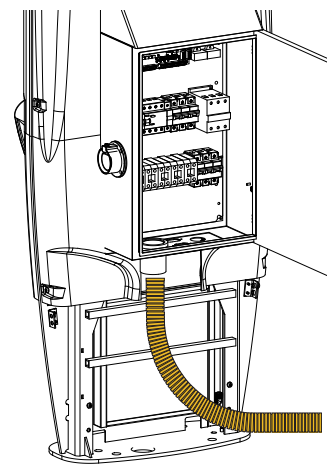

2a. Open AC box. Fit underground conduit & feed in power

Using the key provided unlock and open the door. Trim and fit the conduit into the supplied fitting and feed 300mm of wiring through into the interior ready for commissioning. Seal the conduit into the fitting with Jointing Cement so that no water or debris can enter.

Trim the conduit to fit into the supplied fitting and feed 300mm of wiring through into the interior ready for commissioning. Seal the conduit into the fitting with Jointing Cement.

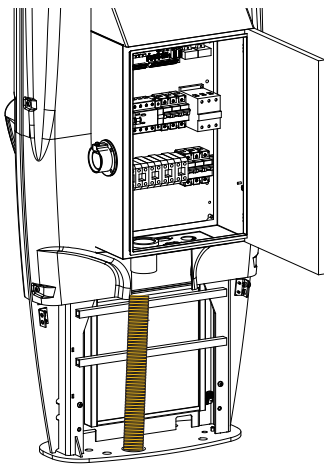

Fix to ground and feed power

Model TRI93-50-02

3. Trim and fit rear radiator panel

The rear radiator panel provides the exit point for the conduit.

Cut the three tabs on the lower right hand of the radiator panel to remove the material to open the conduit exit point.

Veefil is now ready for wiring and commissioning.

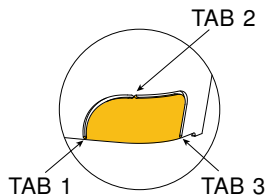
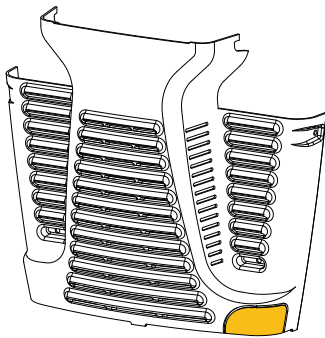

4. Replace rear radiator

Replace the rear radiator panel with washers and security screws. Ensure the conduit fits in the cut out and the four fixing screws easily engage.

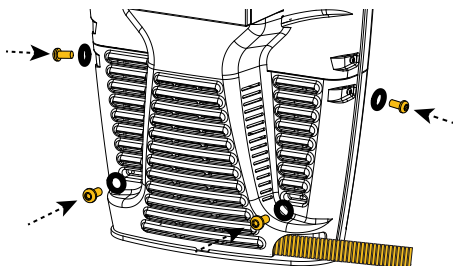

Wire & Commission Overview

Model TRI93-50-02



CAUTION

Wiring and commissioning the charger is to be done by qualified electrical personnel only.

Connect as shown in this wiring diagram.

Use Copper Conductors only.

When completed, switch on the breaker and check the interface panel on the front door is cycling through the icons. Each icon will be lit in turn on the interface panel.

Finally close and lock the door to secure the Veefil ready for use.

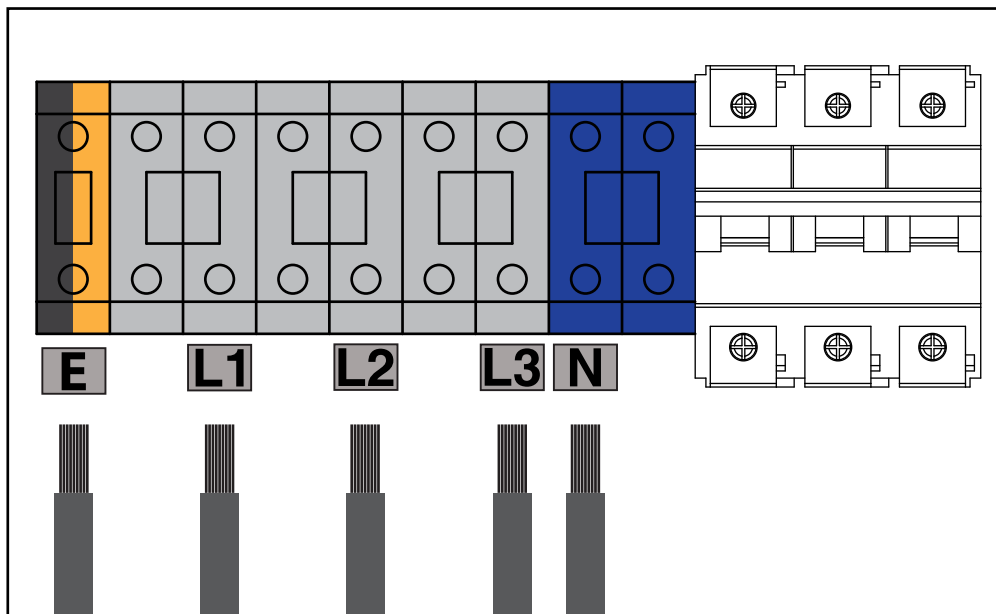

Contact your supplier to run through the diagnostic testing to commission the unit.

Operating Instructions

Model TRI93-50-02

Operation of model TRI93-50-02, 50kW DC+AC (worldwide excluding USA) is identical to TRI93-50-01 and TRI93-50-01-US apart from the following:

DC or AC button
As described in item 3.

The Interface Panel

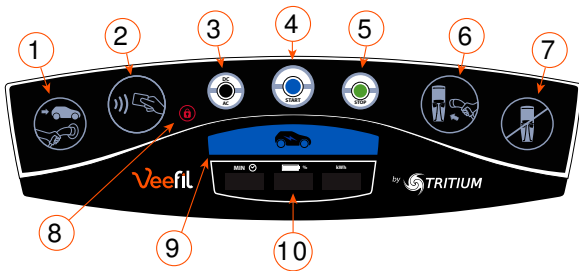

1. Connect Plug to Car

Icon flashes when the unit is available for use.

2. Activation

Swipe your card over this area or use your APP or SMS to activate the user interface, and to also unlock a charging session.

3. DC or AC

If your model allows for simultaneous DC and AC charging this button toggles between the charge states when both plugs are actively charging.

4. Start

Push to start the charging session.

5. Stop

Push to stop the charging session.

6. Return Plug to Charger

Icon flashes to indicate that the charging

session is complete and the plug should be returned to the plug holder.

7. Not in Service

Icon will light up when the charger is not in service.

8. Locked symbol

Lit when a charging session is in progress and the interface panel is locked.

9. Charging indicator

Will glow when a charging session is in progress.

10. LED information displays

Displays minutes, battery percentage during charge, kilowatts delivered, fee charged.

Maintenance Instructions - all models

The following maintenance can be performed by the owner/user. All other servicing is to be conducted by qualified service personnel.

General exterior maintenance

Regular cleaning is recommended to avoid accumulation of debris/dust/dirt on or around the unit. Wipe surfaces with a soft cloth dampened with water, or use alcohol based cleaner for harder to remove marks.

Do not spray with high pressure cleaning hoses or use abrasive chemicals.

Maintenance Checklist

1. Surfaces
2. Metalwork
3. Interface Panel

4. Plug Holders
Ensure there is no debris inside the plug holders.

5. Plug Plates
Check the stainless steel plug plates and use appropriate lubricant on the hinges if required.

6. Charging Plugs
Check the plugs for accumulation of debris and inspect the contact pins for corrosion. If corrosion is present contact your supplier.

7. Radiator
Regularly check the radiator. Gently hose

through the slots in the radiator panel to remove any debris.

Snowfall areas

Regularly remove snow build up if present in front of the radiator panels.

