

VICTROLA™

by *innovative* technology.



MODEL: VTA-204B

**6-IN-1 NOSTALGIC
ENTERTAINMENT CENTER
WITH PC RECORDING**

Important Safety Instructions 3
Product Overview 4
Setup / Basic Operation 7
Listening to a Vinyl Record 7
Listening to a CD 8
Listening to the FM Radio 9
Listening to an External Audio Device (AUX Mode) 9
Listening to an External Audio Device (Bluetooth Mode) 10
Listening to a Cassette Tape 10
Connecting to a Computer for recording..... 11
Maintenance / Proper Handling 14
Specifications 15
Troubleshooting Guide 16
FCC Statement and other Warnings 18

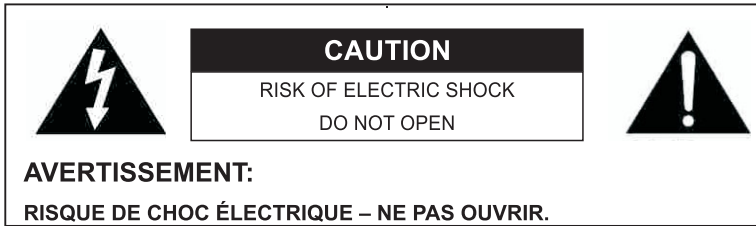

- This lightning flash with arrowhead symbol within an equilateral triangle is intended to alert the user to the presence of non-insulated "dangerous voltage" within the product's enclosure that may be of sufficient magnitude to constitute a risk of electric shock.

- **Warning:** To reduce the risk of electric shock, do not remove cover (or back) as there are no user-serviceable parts inside. Refer servicing to qualified personnel.

- The exclamation point within an equilateral triangle is intended to alert the user to the presence of important operating and maintenance instructions in the literature accompanying the appliance.

CAUTION: To reduce the risk of fire or electric shock, do not expose this appliance to rain or moisture.

WARNING: To prevent electric shock, do not use this (polarized) plug with an extension cord, receptacle or other outlet unless the blades can be fully inserted to prevent blade exposure.



WARNING: Invisible laser radiation when open and interlock failed or defeated. Avoid direct exposure to laser beam.

PRODUCT COMPLIES WITH DHHS RULE 21 CFR SUBCHAPTER J IN EFFECT AT DATE OF MANUFACTURE



This equipment is a Class II or double insulated electrical appliance. It has been designed in such a way that it does not require a safety connection to electrical earth.

IMPORTANT SAFETY INSTRUCTIONS

1. Read these instructions – All the safety and operating instructions should be read before this product is operated.
2. Keep these instructions- The safety and operating instructions should be retained for future reference.
3. Heed all warnings – All warnings on the appliance and in the operating instructions should be adhered to.
5. Do not use this apparatus near water – The appliance should not be used near water or moisture – for example, in a wet basement or near a swimming pool, and the like.
6. Clean only with dry cloth.
7. Do not block any ventilation openings. Install in accordance with the manufacturer's instructions.
8. Do not install near any heat sources such as radiations, heat registers, stoves, or other apparatus (including amplifiers) that produce heat.
9. Do not defeat the safety purpose of the polarized or grounding plug. A polarized plug has two blades with one wider than the other. A grounding plug has two blades and a third grounding prong. The wide blade or the third prong is provided for your safety. If the provided plug does not fit into your outlet, consult an electrician for replacement of the obsolete outlet.
10. Protect the power cord from being walked on or pinched particularly at the plugs, convenience receptacles, and at the point where they exit from the apparatus.
11. Only use attachments/accessories specified by the manufacturer.
12. Use only with the cart, stand, tripod, bracket, or table specified by the manufacturer, or sold with the apparatus. When a cart or rack is used, use caution when moving the cart/apparatus combination to avoid injury from tip-over.
13. Unplug the apparatus during lightning storms or when unused for long periods of time.
14. Refer all servicing to qualified personnel. Servicing is required when the apparatus has been damaged in any way, such as power supply cord or plug is damaged, liquid has been spilled or objects have fallen into the apparatus has been exposed to rain or moisture, does not operate normally, or has been dropped.



15.

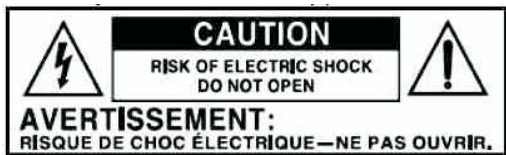







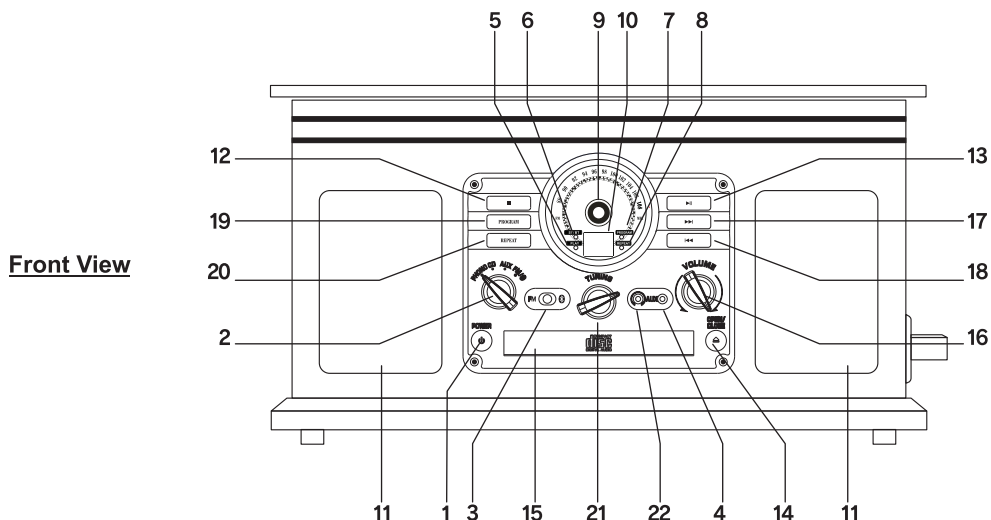

- This lightning flash with arrowhead symbol within an equilateral triangle is intended to alert the user to the presence of non-insulated “dangerous voltage” within the product’s enclosure that may be of sufficient magnitude to constitute a risk of electric shock.
 - **Warning:** To reduce the risk of electric shock, do not remove cover (or back) as there are no user-serviceable parts inside. Refer servicing to qualified personnel.
 - The exclamation point within and equilateral triangle is intended to alert the user to the presence of important operating and maintenance instructions in the literature accompanying the appliance.
16.  This equipment is a Class or double insulated electrical appliance. It has been designed in such a way that it does not require a safety connection to electrical earth.
17. The mains plug is used as disconnect device, the disconnect device shall remain readily operable.
18. To reduce the risk of fire or electric shock, do not expose this apparatus to rain or moisture. The apparatus shall not be exposed to dripping or splashing and that no objects filled with liquids, such as vases, shall not be placed on apparatus.
19. Use the equipment in a moderate climate.

ACCESSORIES INCLUDED

- RCA LINE OUT CABLE
- INSTRUCTION MANUAL
- WARRANTY (BACK OF MANUAL)
- 45 RPM ADAPTER
- USB CABLE
- AUDACITY SOFTWARE CD

PRODUCT OVERVIEW



1. **POWER**  Push to turn the unit ON or OFF.
2. **“PHONO, CD, AUX, FM/” SELECTION KNOB**  Rotate to select your desired function.
3. **“FM”, “” SLIDE SWITCH**  Slide to select either FM or Bluetooth.
4. **3.5mm AUX IN JACK** Connects your external source to the AUX IN jack.
5. **PLAY INDICATOR** Illuminates when CD is playing.
6. **ST/BT INDICATOR** Blue light flashes when the unit is waiting for pairing. Blue light stays lit when the external device is connected to the unit. Red light illuminates when station is received in stereo playing mode.
7. **PROGRAM INDICATOR** Illuminates when the program playback is set.
8. **REPEAT INDICATOR** Red light stays lit when all tracks repeat. Red light flashes when a single track is repeating.
(Note: *This indicator only works in CD mode.*)
9. **LED DISPLAY**
10. **TUNING DIAL POINTER**
11. **STEREO SPEAKERS**
12. **STOP**  Press to stop playback or cancel the program setting.
13. **PLAY/PAUSE**  Press to start playback, press again to pause.
(Note: *This button only works in CD, Bluetooth mode.*)
14. **OPEN/CLOSE**  In CD mode, use to open and close the disc tray.
15. **DISC TRAY**
16. **“VOLUME” KNOB** Turn to adjust volume.
- 17/18. **NEXT/PREVIOUS TRACK & FF/REWIND ( )**
In CD Mode, press once to skip to the next/previous track. Press and hold to fast forward/rewind.
(Note: *This button will not work in PHONO, FM, AUX mode*)
19. **“PROGRAM”** Press to set the program playback.
(Note: *This indicator only works in CD mode.*)
20. **“REPEAT”** Press to select the repeat mode.
(Note: *This indicator only works in CD mode.*)
21. **RADIO TUNER KNOB** In FM mode turn to tune in a station.
22. **3.5mm EARPHONE JACK**
Accepts headphone/earphone plugs.

Right Side View

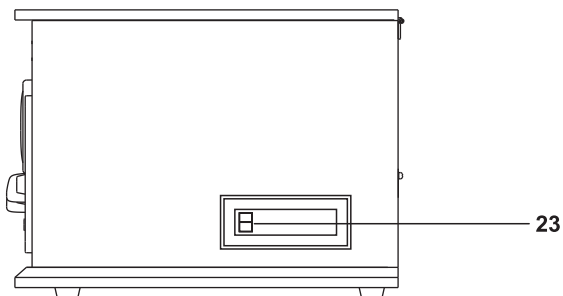

23. **CASSETTE FF & EJECT** Press halfway to fast forward, press all the way to end and eject the tape.

Rear View

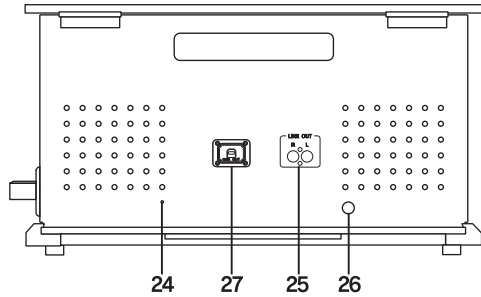

24. FM wire antenna

While tuned to a station in FM mode, extend the wire and reposition to adjust for best reception.

25. LINE OUT jacks

For amplifier device with RCA auxiliary input sockets, insert the white and red plugs on the RCA cable into the unit. Insert the opposite end into the amplifier device. Be sure to connect the white plug to the white jack and the red plug to the red jack.

26. AC Power Cord

Connect the AC plugs into a wall outlet.

It is strongly recommended that this product should be operated only from the type of power source indicated on the marking label.

27. PC-USB Port

Connect the turntable to your computer by using an included USB Cable.

Parts of the Turntable

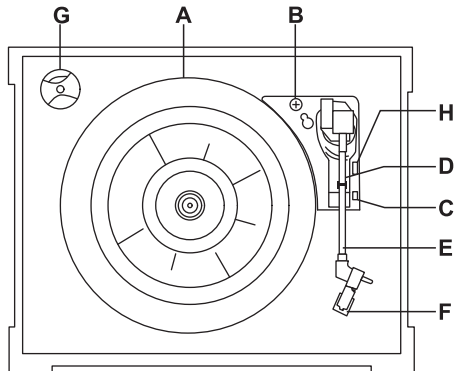

A. Turntable

B. Safety Screw (for transport) Before using the unit, turn the screw clockwise using a coin or screwdriver.

Important: *When you transport the unit, turn the screw counterclockwise to secure the turntable.*

C. Speed Selector

D. Tone Arm holder

E. Tone Arm Before use, completely loosen the fixed rope on the tone arm and lift the tone arm up.

F. STYLUS

G. 45 RPM adaptor

H. Cue Lever

SETUP / BASIC OPERATION

Setup

1. Remove white protective needle cover by gently pulling towards front of unit.
2. Remove any packaging materials from the unit.
3. Connect the AC power cord to a wall outlet.

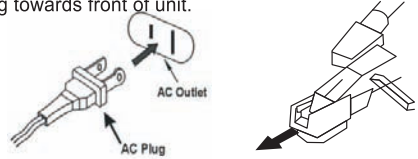

Note:

- It is strongly recommended that this product should be operated only from the type of power source indicated on the marking label.
- To prevent interference, avoid bundling audio signal cables together with the AC power cord.

Basic Operation

1. Push the POWER button to turn the unit on.
2. Select the source by turning the selection knob (PHONO/AUX/CD/FM/BT)
3. Rotate the VOLUME knob to adjust to the desired sound level.

Listening through RCA LINE OUT

For amplifier device listening, first reduce the volume level to minimum. Insert the white and red plugs on the RCA cable into the unit, then insert the opposite end into the amplifier device. Be sure to connect the white plug to the white jack and the red plug to the red jack.

Listening through Earphones/Headphones (not included)

For private listening, first reduce the volume level to minimum. Insert your headphones' plug into the 3.5mm jack, then adjust the volume up by turning the VOLUME knob.

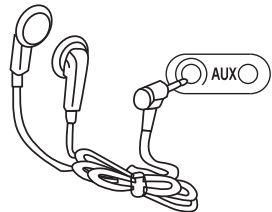

Note: The speakers will automatically be deactivated while headphones are plugged in.

CONDENSATION WARNING:

When the unit is moved from a cold or warm place, or is used following a sudden temperature change, there is the danger that water vapor in the air may condense on the unit, preventing proper operation. In such cases, leave the unit for 1-2 hours after plugging it into an AC outlet to allow it to stabilize at the temperature of its surroundings.

LISTENING TO A VINYL RECORD

1. Before use, completely loosen the TRANSPORTATION SCREW by turning it clockwise with a coin or screwdriver. Detach the stylus guard (white plastic cover).
2. Turn the unit ON by pressing the POWER button.
3. Set the FUNCTION KNOB to the PHONO position.
4. Gently open the dust cover. Be careful not to pinch your finger.
5. Put the record on the turntable. Select the speed. When playing a 45 RPM record, use the included 45 adaptor.
6. Gently push the CLAMPER to the right to release the TONE ARM.
7. Raise the CUE LEVER to lift the TONE ARM off the tone arm support.
8. Move the TONE ARM gently to the edge of the record (or the starting point of a track). The turntable will begin to turn.
9. Gently lower the TONE ARM by slowly releasing the CUE LEVER. You can lower the TONE ARM manually if the CUE LEVER has not been raised.

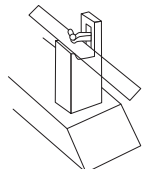
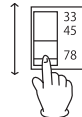

10. Turn the VOLUME KNOB to adjust the volume.
11. When playback has finished, slightly lift the tone arm using the CUE LEVER and return it to the TONE ARM holder. The rotation stops.

Important:

- Closing the top cover will help prevent dust from settling on the turntable.
- Always relock the tone arm clip before transporting the unit.
- Do not place anything on top of the turntable cover, especially while playing a record.

LISTENING TO A CD

1. Select "CD" function.
(Note: *When no disc is set, "no" will appear on the display.*)
2. Press the OPEN/CLOSE (▲) button
(Note: *This button only works in CD mode.*)
3. Place a disc on the tray with the printed label face up.
4. Press the OPEN/CLOSE button (▲) to close the tray.
5. Press the PLAY/PAUSE (▶||) to begin playback.
(Note: *The CD playback will start automatically.*)
6. To temporarily pause playback, press the PLAY/PAUSE button (▶||). Press again to resume.
7. To skip tracks forward or backward, press the corresponding skip button (◀◀ or ▶▶).
Pressing ◀◀ once will restart the current track. Pressing ◀◀ twice in succession will return to the beginning of the previous track.
8. To fast forward / rewind within a track, press and hold down the corresponding skip button until the desired position is reached.
9. To stop playback, press the STOP ■ button.

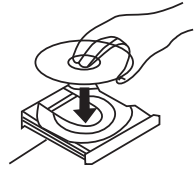

Important:

- Never place more than one disc on the tray.
- The disc must be placed in the center of the disc tray. An incorrectly loaded disc can permanently damage the tray door mechanism.
- Do not push the CD tray – always use the OPEN/CLOSE button.
- It takes a moment for the unit to load a disc, during which all buttons will be temporarily deactivated.

Repeat Playback

Each time the REPEAT button is pressed, the repeat mode will cycle through the following options:

REPEAT 1(Repeat one track)

The repeat indicator will flash and the current track will be played repeatedly. If you press the (◀◀ or ▶▶) button to select another track, the track you select will be played repeatedly.

REPEAT ALL (Repeat the entire CD)

The repeat indicator will stay lit and the entire CD will be played repeatedly.

Notes:

- Repeat playback works with CD discs only.

Programmed Playback

Up to 20 tracks can be programmed to play in the desired order.

Notes:

- Programmed playback works with CD discs only.

1. Select "CD" mode, then load a CD.

2. While the CD is stopped, press the PROGRAM button.
3. "PROGRAM" indicator lights up and "01" blinks on the display.
4. Press (◀◀ or ▶▶) to select a track number.
5. Press the PROGRAM button again to set the next program track, "02" appears and blinks.. Repeat steps 4 thru 5 to program the additional tracks.
6. When the selection of track numbers has been finished, press the PLAY button (▶▶) to start program playback.

(Note: *when all 20 program tracks are set, you press PROGRAM button and "FI" will appear on the display*)

7. To cancel the program mode, press the STOP (■) till the program indicator won't light.

To check the programmed order

In the stop mode, press (◀◀ or ▶▶) repeatedly to show the track numbers which have been programmed.

To add a track to the end of the programmed order:

In the stop mode, press the PROGRAM button.

Select a track number by pressing (◀◀ or ▶▶), then press the PROGRAM button.

The current track will be added to the end of the program.

LISTENING TO A FM RADIO

1. Select "FM/ 📻 " mode.
2. Slide the slide switch on "FM".
3. Tune to the desired station using the Radio Tuner Knob.

Note: *In FM Mode, the "ST/BT" indicator lights up red when tuning in the stereo reception station.*

Adjusting for Best Reception

FM broadcast: Extend and reposition the FM antenna.

LISTENING TO AN EXTERNAL AUDIO DEVICE (AUX MODE)

In AUX (auxiliary) mode, this unit can play audio from an external audio source (iPod, MP3 Player, Portable CD Player, etc.)

Playing via 3.5mm AUX-IN Jack on the Front Unit:

1. Turn the unit ON by pressing the POWER button.
2. Set the FUNCTION KNOB to the AUX position.
3. Connect the 3.5mm aux-in cable (included) into the 3.5mm AUX-IN Jack to play an external audio source, such as CD player, tablet, MP3 player, etc.

LINE-OUT Jacks on the Back of Unit:

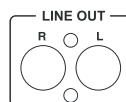

You can connect a CD player, DVD player, DVR, TV, etc. to this unit. Connect the external source with an RCA component cable (NOT included). Make sure to connect the white plug to white jack (left) and the red plug to the red jack (right).



LISTENING TO AN EXTERNAL AUDIO DEVICE (BLUETOOTH MODE)

In BT (Bluetooth) mode, this unit can play music from external devices which have a built-in Bluetooth feature.





GETTING CONNECTED USING BLUETOOTH

1. Select "FM/  " mode.
2. Slide the slide switch on "  " and the ST/BT indicator will flash blue.
3. Turn ON the Bluetooth function on your external device.

NOTE: The effective distance between your external device and this apparatus is 10 meters (33ft).

4. Wait for "Wooden Music Center" to appear on the paired devices list of your external device and press "Wooden Music Center".

In some instances: a window will ask you a password. Fill in "0000" then press "OK" on your external device.

5. A few seconds later your Bluetooth connection is successful and the blue indicator stays lit.
6. Press the PLAY/PAUSE button () to begin playback.
7. To temporarily pause playback, press the PLAY/PAUSE button (). Press again to resume.
8. To skip to the previous or next tracks, press the corresponding skip button ( or ) to listen.

NOTE: Stop, fast forward / rewind are only available on your external device.

LISTENING TO A CASSETTE TAPE

1. Load an audio cassette tape into the unit (located on the left side of the unit). Playback will automatically begin.
2. Press button halfway to Fast Forward the tape.
Press button lightly and playback will resume.
3. Press button completely down to end playback and eject tape.

NOTE: When loading in a cassette tape, the SELECTION KNOB function will be temporarily overridden until the cassette tape is ejected.

CONNECTING TO A COMPUTER FOR RECORDING

BEFORE USING THE PC RECORDING FUNCTION

Make sure that your USB turntable is plugged into the computer and both the computer and the turntable are plugged in and on.

INSTALLING THE AUDACITY SOFTWARE (PC)

1. Plug in your turntable to an AC outlet and connect the PC-USB port on the Turntable to the USB port of your computer.
2. Turn on your turntable.
3. Windows system will detect a new device and that it is available to use.
4. Insert the CD that came with your USB turntable.
5. Run the file "install audacity-win-2.2.2.exe" to install Audacity software. Once installed, run the Audacity program.

INSTALLING THE AUDACITY SOFTWARE (MAC)

1. Insert the included CD
2. Open the CD icon on the desktop.
3. Drag the installation folder for audacity to your hard drive. We recommend that you move the folder to your "Applications" folder.
4. A window will come up which shows the files copying.
5. EJECT the CD.
6. Open "Audacity" from where you moved it to on your hard drive.

NOTE: For the most up to date manuals, software, instructional details, troubleshooting or other downloadable content, please go <http://audacityteam.org>.

RUNNING AUDACITY SOFTWARE

Note: Please review the software license and distribution restrictions found on the software disc. Use of the Audacity software is subject to those conditions and restriction.

For additional help with recording and editing music by using the Audacity software, please visit <http://audacityteam.org>.

1. Run the Audacity from the Windows start menu or double click the Audacity icon on your computer desktop.
2. The Audacity main screen appears. You will find the Record, Play, Pause, Stop, Skip to Start and Skip to End control buttons here. Use the File, Edit, Select, View, Transport, Tracks, Generate, Effect and Analyze menus from your computer screen to Save, Export or Edit the music.

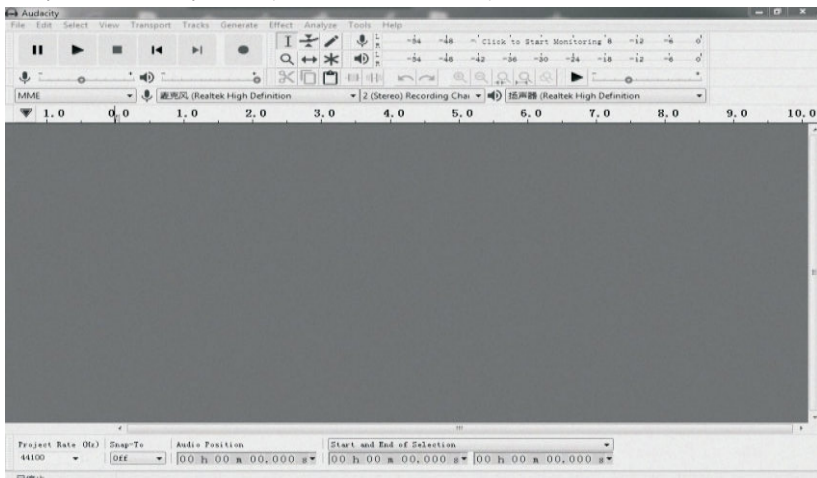



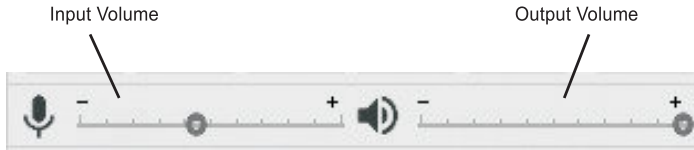

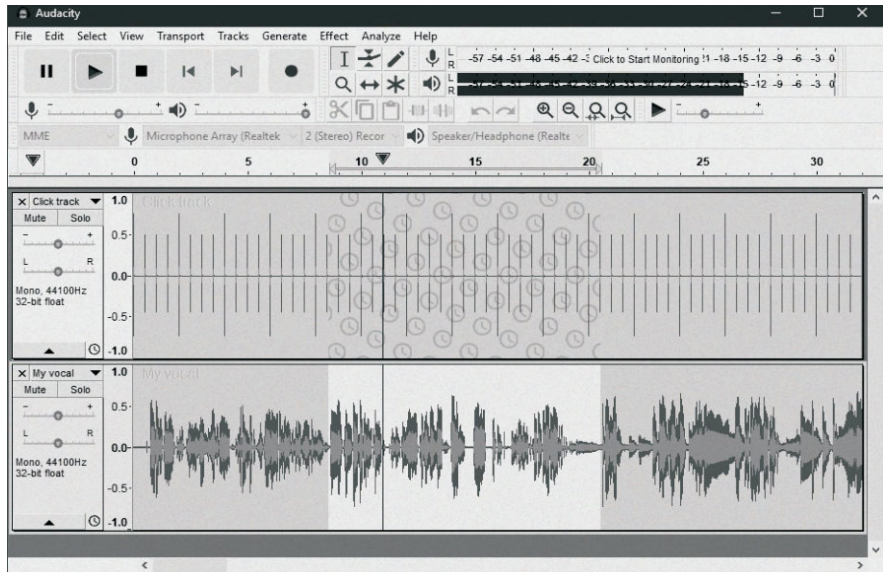

- Adjust the input and output volume by sliding the Input and Output Volume bars.



- Click the record button to start recording, left and right tracks will show on your computer screen. If you cannot see the sound waves appear on the Interface when recording, adjust the Input volume bar.



- Use the Audacity control panel to record or listen the music you have recorded
 - Click  button to start recording.
 - Click  the button to skip to start;
 - Click  the button to skip to end;
 - Click  the button to play;
 - Click  the button to pause;
 - Click  the button to stop.



EXPORT THE MUSIC FILES TO WAV OR MP3 FORMAT

Once you have finished recording, make sure you save your recorded music to the computer.

- Click File menu and move down to "Export" to convert the file to WAV format or MP3 format.
- Click on WAV or MP3 format you want to save the music as in pull down menu of "Save as type" field, and you will be asked for the file name of your recorded music

NOTE: Audacity does not export MP3 files directly. If you want to encode your recorded music to MP3 format, you need to download the LAME MP3 encoder either in the CD provided or under the page "Other Audacity Downloads for Windows" of the website <http://audacityteam.org>.

Note: Normally, Audacity will automatically locate the Lame file that you installed. However, if you change default directory of Lame program, you may need to manually locate it by using Audacity < Edit < Preference < Libraries and the click "Locate" button on computer screen to browse "lame_enc.dll" file where the directory you have installed. See Fig.1 & 2 below and click OK to finish manual installation.

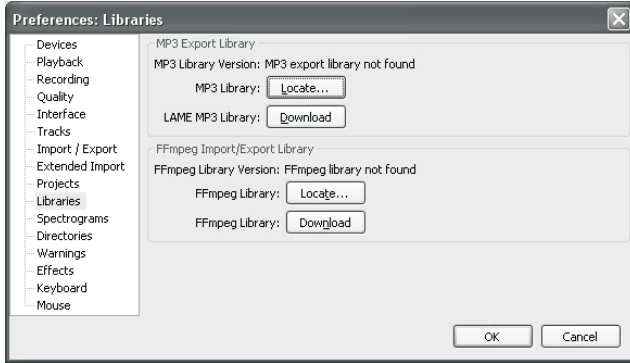

Fig. 1

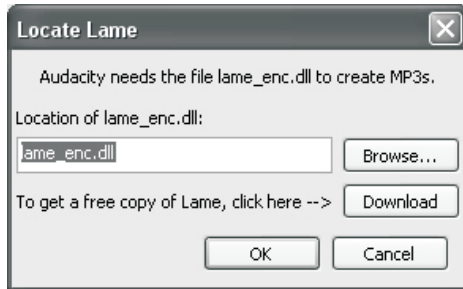

Fig.2

MAINTENANCE / PROPER HANDLING

Compact Disc Handling

- Always place the disc on the disc tray with the label side facing upward (compact discs can be played /recorded only on one side)
- To remove a disc from its storage case, press down on the center of the case and lift the disc upward, holding it carefully by its edges.
- To clean a disc, wipe the surface from the center hole outward towards the outer edge with a soft, dry cloth.
- Never use such chemicals as record spray, antistatic sprays or fluid, benzine or thinner to clean discs; they will irreparably damage the disc's plastic surface.
- Discs should be returned to their cases after use to protect from dust and scratches.
- Do not expose discs to direct sunlight, high humidity, or high temperature for extended periods of time.
- Printable CD-R and CD-RW discs are not recommended, as the label side may become sticky and damage the unit.
- Use a soft oil-based felt-tipped pen to write information on the label side. Never use a ball-point or hard-tipped pen, as doing so may damage the recorded side.
- Do not use irregularly-shaped CDs (octagonal, heart shaped, business card size, etc), as they will damage the unit.
- Read all precautions supplied with any CD-R or CD-RW disc
- Never handle a disc with dirty fingers.
- Never insert a disc that has a crack on the surface.

Handling Vinyl Records

- Do not touch the record's grooves. Only handle records by the edges or the label with clean hands. Touching the record surface will cause your record's quality to deteriorate.
- To clean a record, use a soft anti-static cloth to gently wipe the record surface.
- Keep records in their protective sleeves when not in use.
- Always store records upright on their edges
- Avoid placing records in direct sunlight, close to a heat source (radiators, stoves, etc.), or in a location subject to vibration, excessive dust, heat, cold or moisture.

General Care

- When removing the power plug from the wall outlet, always pull directly on the plug. Never pull the cord.
- To keep the laser pickup clean, do not touch it, and do not forget to close the disc tray.
- Do not attempt to clean the unit with chemical solvents as this might damage the finish.
- For cleaning, only use a clean, dry cloth.
- In order to shut off the power to this product completely, unplug the power cord from the wall outlet. Be sure to unplug the unit if you do not intend to use it for an extended period of time.

How to Replace the Turntable Stylus

The stylus should last about 50 hours under normal use. However, it is recommended that the stylus be replaced as soon as you notice a change in sound quality. Prolonged use of a worn-out stylus may damage the record. The highest speed of 78 RPM records would wear out the stylus more quickly.

Removing the old stylus:

1. Set a screwdriver at the tip of the stylus and push downward (A).
2. Remove the stylus by pulling it simultaneously downward and forward.

Installing a new stylus:

1. Hold the front tip of the stylus and insert its rear edge (B) first.
2. Push the stylus upwards (C) until the tip locks into place.

Caution:

- *Do not bend the stylus.*
- *Do not touch the needle to avoid injury your hand.*
- *Turn off the unit's power before you replace the stylus.*
- *Keep out of reach of children.*

