

B922BL

Bluetooth Sport Headset

User Manual

Versions: 1.0.0

Release Date: 2015-10-26

Table of content

Table of content	1
1 Product Overview	1
1.1 General Description	1
1.2 Features.....	1
2 Pin Definitions	2
2.1 CW6687B.....	2
2.1.1 Package.....	2
2.1.2 Pin Assignment	2
2.1.3 Pin Descriptions	3
3 CPU Core Information	5
3.1 Architecture	5
3.2 Instruction Set	5
3.3 Memory Mapping	8
3.3.1 Program Memory Mapping	8
3.3.2 External Data Memory Mapping	8
3.3.3 Internal Data Memory Mapping.....	9
3.4 Interrupt Processing.....	10
3.4.1 Interrupt sources	10
3.4.2 Interrupt Priority.....	12
3.5 Special Function Register Mapping (SFR).....	12
3.6 Extend Special Function Registers Mapping (XSFR)	13
3.7 CPU and Memory related SFR Description	14
3.8 CPU breakpoint	23
4 Reset Generation.....	25
4.1 Power-on Reset (POR).....	25
4.2 System Reset	25
4.2.1 LVD.....	26

4.2.2	RTCC Reset.....	28
4.2.3	Watchdog Reset	28
4.2.4	Port Wakeup Reset.....	28
4.3	Clock System	28
4.3.1	Clock Control	28
4.3.2	Operation Guide	35
4.3.3	Clock Gating.....	35
4.3.4	Phase Lock Loop (PLL).....	35
5	Low Power Management	40
5.1	Power Saving Mode	40
5.1.1	Sleep Mode.....	40
5.1.2	Hold Mode.....	40
5.1.3	Idle Mode.....	40
5.1.4	Power Down Mode.....	41
5.2	Power Supply.....	41
6	General Purpose Input/Output (GPIO).....	46
6.1	Overview	46
6.2	Features.....	46
6.3	Function multiplexing.....	46
6.4	GPIO Special Function Registers	48
6.5	Port interrupt and wakeup.....	63
6.5.1	Wakeup registers.....	63
6.6	Operation Guide.....	65
7	Timers.....	66
7.1	Timer0	66
7.1.1	Timer0 Special Function Registers.....	66
7.2	Timer1	67
7.2.1	Timer1 Special Function Registers.....	67
7.3	Timer2	69
7.3.1	Timer2 Features.....	69

Table of content

7.3.2	Timer2 Special Function Registers.....	70
7.4	Timer3.....	71
7.4.1	Timer3 Features.....	72
7.4.2	Timer3 Special Function Registers.....	72
7.5	Watchdog Timer (WDT)	73
7.5.1	Watchdog Wake up	73
7.5.2	Watchdog SFR.....	74
7.6	Independent Power Real Time Clock Counter (IRTCC)	75
7.6.1	IRTCC Controller	75
7.6.2	IRTCC Timer	75
7.6.3	Communication with IRTCC Timer.....	75
7.6.4	IRTCC Special Function Registers.....	77
7.6.5	IRTCC components description	79
7.6.6	IRTCC Operating Guide	82
8	Universal Asynchronous Receiver/Transmitter (UART)	88
8.1	UART0.....	88
8.1.1	Overview.....	88
8.1.2	UART0 Special Function Registers	89
8.2	UART1.....	91
8.2.1	Overview.....	91
8.2.2	UART1 Special Function Registers	91
8.3	Operation Guide.....	95
8.4	BT Control Register	96
9	Direct Memory Access (DMA)	97
9.1	DMA for IRAM	97
9.2	DMA for RAM2	97
9.3	DMA for DECRAM.....	97
9.4	DMA for IROM.....	98
10	IR receiver.....	99
10.1	IR frame format.....	99

10.2	IR Receiver Control Registers	100
10.3	IR Receiver Operation Guide	102
11	SPI	103
11.1	SPI0	103
11.1.1	SPI0 Special Function Registers	103
11.1.2	SPI0 Operation Guide	105
11.2	SPI1	106
11.2.1	SPI1 Special Function Registers	106
11.2.2	SPI1 Operation Guide	108
12	External Memory Interface (EMI)	110
12.1	EMI Control Registers	110
13	Audio Terminal (DAC)	114
13.1	Features	114
13.2	DAC Special Function Registers	114
13.2.1	DAC Register Mapping	114
13.2.2	Function of DAC Control Registers	115
13.2.3	EQ and DRC Control Register	120
13.3	Operation Guide	124
13.3.1	DAC Operation Guide	124
13.3.2	EQ Operation Guide	124
14	SARADC	125
14.1	Features	125
14.2	ADC Pin Mapping	125
14.3	SARADC Special Function Registers	125
15	CRC16 /LFSR16/LFSR32	128
15.1	CRC16	128
15.1.1	Features	128
15.1.2	CRC16 Special Function Registers	128
15.2	LFSR16	129
15.2.1	Features	129

Table of content

15.2.2	LFSR16 Special Function Register	129
15.3	LFSR32	130
15.3.1	Features	130
15.3.2	LFSR32 Special Function Registers.....	130
16	Characteristics	131
16.1	PMU Parameters	131
16.2	CORE PLL Parameters.....	131
16.3	General purpose I/O Parameters	131
16.4	Audio ADDA Parameters	132
16.5	RF Analog Blocks	132
17	Package Outline Dimensions	134
17.1	QFN32.....	134
	Revision History.....	i

1 Product Overview

Bluetooth Audio Player Microcontroller

1.1 General Description

CW6687B is a compact, highly integrated system on chip for Bluetooth v4.2 with Enhanced Data Rate applications. This SOC complies with Bluetooth specifications and is backward-compatible with Bluetooth 2.1, 2.0 or 1.2 systems.

This Bluetooth includes a data rate of 1M/2M/3Mbps RF with a performance of Tx: 0dBm, Rx: -85dBm, and full-duplex UART, SPI, interface with EDR applications.

It also integrates a DSP co-processor, a PLL, and a CODEC to provide exceptional voice and audio quality.

In addition, to provide easy accessibility and transferability to other auxiliary products,

1.2 Features

- Supports Bluetooth v.4.2+EDR; backward-compatible with BT v.1.2, 2.0 and 2.1
- SOC supports following versions:
 - Hands Free v.1.6
 - AVCTP v.1.4
 - Headset v.1.2
 - AVDTP v.1.3
 - A2DP v.1.3
 - AVRCP v.1.5
- Class 2 power level, RF Performance: Tx:0dBm, Rx: -85dBm;
- Supports 26M crystal with independently powered real-time clock that supports 32.768kHz internal crystal oscillator
- Supports MP3/SBC/WMA decoder;
- Three Channels 10-bit SARADC;
- Watchdog Timer with on-chip RC oscillator
- Supports full-duplex UART, SPI interface;
- Keypad tone mixer;
- Internal LDO regulator : 1.35V to 1.2V, 5V to 3.3V;
- Built-in buck converter, DC-DC 5V to 1.35V ;
- Power on Reset
- Integrated 24bits DSP core that supports:
 - Noise suppressor to eliminate unwanted noise and hum without altering enhanced audio quality
 - Echo cancelation
 - SBC audio format decoding
 - Automatic volume control for speaker output
- 16bit Stereo DAC with >90dB SNR, embedded with 2 class A/B headphone amplifier

- 16bit Stereo ADC with >90dB DR
- Internal charger current up to 25mA
- Supports dual MIC
- Channels 16 levels Low Voltage Detector

2 Pin Definitions

2.1 CW6687B

2.1.1 Package

QFN32

2.1.2 Pin Assignment

Figure 2-1 shows the pin assignments of QFN32 package.

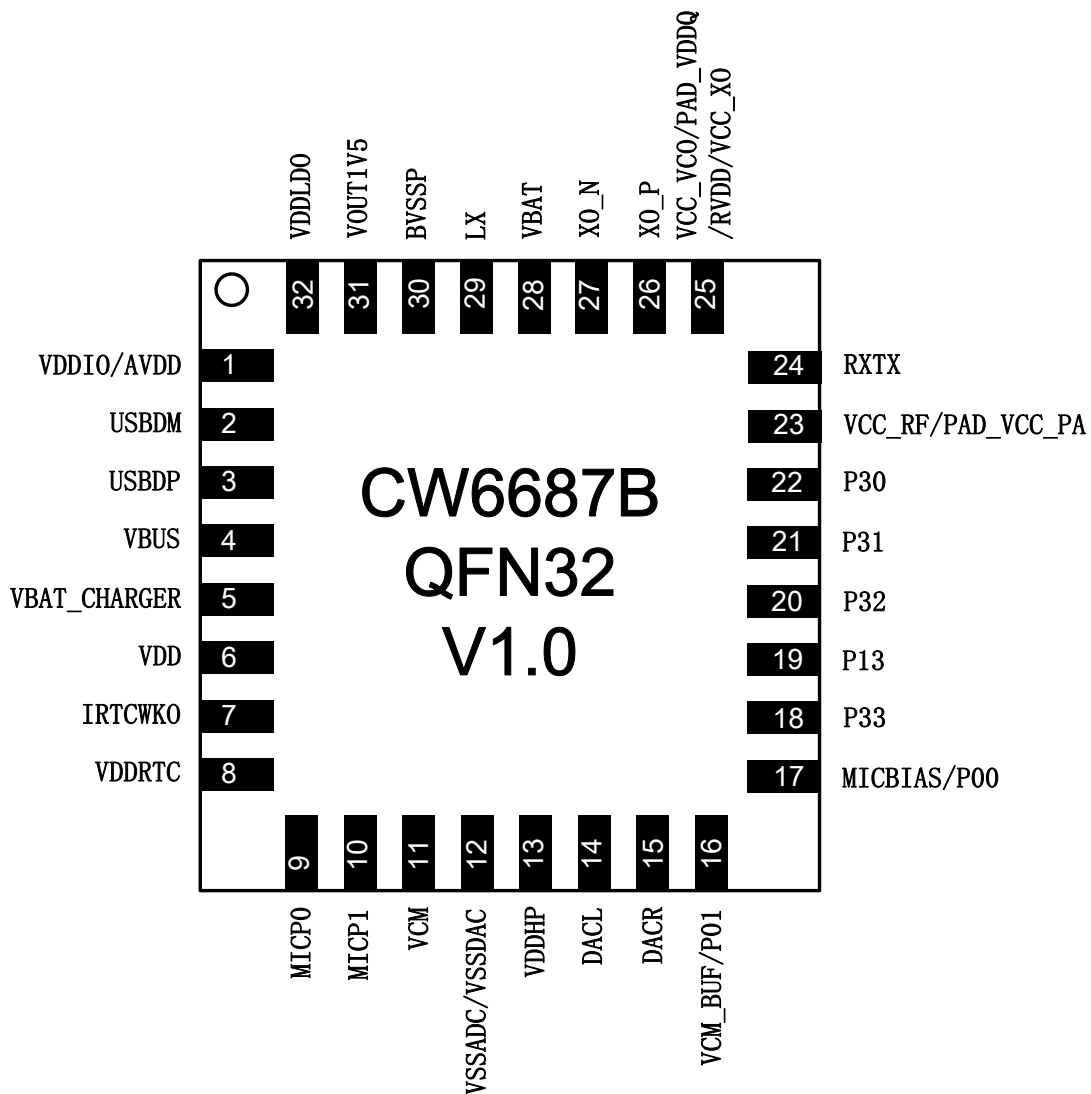

Figure 2-1 Pin assignment for QFN32

2.1.3 Pin Descriptions

Table 2-1 shows the pin descriptions of QFN32 package.

Table 2-1 QFN32 pin description

Pin No.QFN32	Name	Type	Function
1	VDDIO/AVDD	PWR	Power output VDDIO 3.3V
2	USBDM	I/O	USB Negative Input/output
3	USBDP	I/O	USB Positive Input/output
4	VBUS	PWR	Charger power input
5	VBAT_CHARGER	PWR	Charger output to battery
6	VDD	PWR	Core power VDD 1.2V
7	IRTCWKO	I/O	RTC wakeup/Solf Power on/off control pin
8	VDDRTC	PWR	RTC power
9	MICP0	AI	MIC0 Positive input
10	MICP1	AI	MIC1 Positive input
11	VCM	AO	DAC VCM output
12	AVSS	GND	Audio GND
13	VDDHP	PWR	Headphone power output
14	VOUTL	AI/O	DAC left output GPIO input
15	VOUTR	AI/O	DAC right output GPIO input
16	P01/VCM_BUF	I/O	GPIO DAC VCM Buffer AUXR0 UARTTX1 PORT INT/WKUP0 SDDAT2
17	P00/MICBIAS	I/O	GPIO AUXL0 UARTRX1 SDDAT1 SPI0DIN2 MIC Biasing supply
18	P33	I/O	GPIO ADC0/LVD dect ir_input 32K/xosc12m clock output sys_clk_output TRM1CAP

Pin No.QFN32	Name	Type	Function
19	P13	I/O	GPIO ADC5 IISBCLK0
20	P32	I/O	GPIO SDDAT0 SPI0DOUT3/DIN3
21	P31	I/O	GPIO SDCMD SPI0DIN3
22	P30	I/O	GPIO ADC4 SDCLK SPI0CLK3
23	PAD_VCC_IF/VCC_RF/PAD_VCC_PA	PWR	Power VCC
24	RXTX	AO	RF Rx and Tx pin
25	VCC_VCO/VCC_XO/PAD_VDDQ	PWR	Power VCC
26	XO_P	A I/O	BT 26MHz XOSC Positive Pin
27	XO_N	A I/O	BT 26MHz XOSC Negative Pin
28	VBAT	PWR	PMU Power input
29	LX	A I/O	Switch Node Connection to Inductor
30	BVSS	GND	GND
31	VOUT1V5	PWR	BUCK DC/DC 1.5V power
32	VDDLDO	PWR	LDO power input

3 CPU Core Information

3.1 Architecture

The AXC51-CORE employs a pipelined architecture that greatly increases its instruction throughput over the standard 8051 architecture. In a standard 8051, all instructions except for MUL and DIV take 12 or 24 system clock cycles to execute, and usually have a maximum system clock of 12MHz. In contrast, the AXC51-CORE executes most of its instructions in 1 system clock cycle. With the system clock running at 48 MHz, it has a peak throughput of 48 MIPS running in the on-chip SRAM area.

3.2 Instruction Set

The instruction set of the AXC51-CORE is fully compatible with the standard MCS-51TM instruction set; standard 8051 development tools can be used to develop software for the AXC51-CORE. All instructions of AXC51-CORE are the binary and functional equivalent of their MCS-51TM counterparts, including its op-codes, addressing modes and effect on PSW flags. However, the instruction timing is different than that of the standard 8051. Table 3 1 shows AXC51-CORE Instruction Set Summary.

Table 3-1 AXC51-CORE Instruction Set Summary

Number of Bytes	Mnemonic	Operands	Clock Cycles (running in IRAM)
1	NOP		1
2	AJMP	code addr	3
3	LJMP	code addr	3
1	RR	A	1
1	INC	A	1
1	INC	data addr	1
1	INC	@Ri	1
1	INC	Rn	1
3	JBC	bit addr, code addr	1 or 3
2	ACALL	code addr	3
3	LCALL	code addr	3
1	RRC	A	1
1	DEC	A	1
2	DEC	data addr	1
1	DEC	@Ri	1
1	DEC	Rn	1
3	JB	bit addr, code addr	1 or 3
1	RET		4
1	RL	A	1
2	ADD	A, #data	1
2	ADD	A, data addr	1

Number of Bytes	Mnemonic	Operands	Clock Cycles (running in IRAM)
1	ADD	A, @Ri	1
1	ADD	A, Rn	1
3	JNB	bit addr, code addr	1 or 3
1	RETI		4
1	RLC	A	1
2	ADDC	A, #data	1
2	ADDC	A, data addr	1
1	ADDC	A, @Ri	1
1	ADDC	A, Rn	1
2	JC	code addr	1 or 3
2	ORL	data addr, A	1
3	ORL	data addr, #data	1
2	ORL	A, #data	1
2	ORL	A, data addr	1
1	ORL	A, @Ri	1
1	ORL	A, Rn	1
2	JNC	code addr	1 or 3
2	ANL	data addr, A	1
2	ANL	data addr, #data	1
1	ANL	A, @Ri	1
1	ANL	A, Rn	1
2	JZ	code addr	1 or 3
2	XRL	data addr, A	1
3	XRL	data addr, #data	1
2	XRL	A, #data	1
2	XRL	A, data addr	1
1	XRL	A, @Ri	1
1	XRL	A, Rn	1
2	JNZ	code addr	1 or 3
2	ORL	C, bit addr	1
1	JMP	@A+DPTR	3
2	MOV	A, #data	1
3	MOV	data addr, #data	1
2	MOV	@Ri, #data	1
2	MOV	Rn, #data	1
2	SJMP	code addr	3
2	ANL	C, bit addr	1
1	MOVC*	A, @A+PC	1
1	DIV	AB	1
3	MOV	data addr, data addr	1
2	MOV	data addr, @Ri	1

Number of Bytes	Mnemonic	Operands	Clock Cycles (running in IRAM)
2	MOV	data addr, Rn	1
3	MOV	DPTR, #data	1
2	MOV	bit addr, C	1
1	MOVC*	A, @A+DPTR	2
2	SUBB	A, #data	1
2	SUBB	A, data addr	1
1	SUBB	A, @Ri	1
1	SUBB	A, Rn	1
2	ORL	C, bit addr	1
2	MOV	C, bit addr	1
1	INC	DPTR	1
1	MUL	AB	1
2	MOV	@Ri, data addr	1
2	MOV	Rn, data addr	1
2	ANL	C, bit addr	1
2	CPL	bit addr	1
2	CPL	C	1
3	CJNE	A, #data, code addr	1 or 3
3	CJNE	A, data addr, code addr	1 or 3
3	CJNE	@Ri, #data, code addr	1 or 3
3	CJNE	Rn, #data, code addr	1 or 3
2	PUSH	data addr	1
2	CLR	bit addr	1
1	CLR	C	1
1	SWAP	A	1
2	XCH	A, data addr	1
1	XCH	A, @Ri	1
1	XCH	A, Rn	1
2	POP	data addr	1
2	SETB	bit addr	1
1	SETB	C	1
1	DA	A	1
3	DJNZ	data addr, code addr	1 or 3
1	XCHD	A, @Ri	1
2	DJNZ	Rn, code addr	1 or 3
1	MOVX	A, @DPTR	2
1	MOVX	A, @Ri	2
1	CLR	A	1
2	MOV	A, data addr	1
1	MOV	A, @Ri	1
1	MOV	A, Rn	1

Number of Bytes	Mnemonic	Operands	Clock Cycles (running in IRAM)
1	MOVX	@DPTR, A	1
1	MOVX	@Ri, A	1
1	CPL	A	1
2	MOV	data addr, A	1
1	MOV	@Ri, A	1
1	MOV	Rn, A	1

3.3 Memory Mapping

3.3.1 Program Memory Mapping

As illustrated in CW6687B, program space is divided into 5 regions: SRAM1, SRAM2, IROM14, IROM10, and MIX_CODE1.

MIX_CODE1 is combined by IROM11, IROM12, IROM13 controlled by CC1 bits.

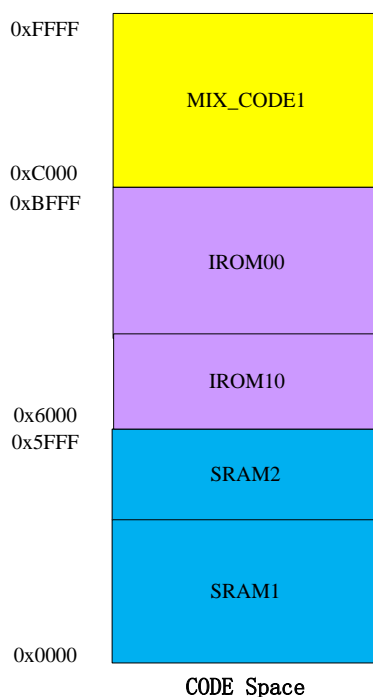

Figure 3-1 Program Memory Organization

3.3.2 External Data Memory Mapping

Figure 3-2 illustrated External Data Memory Mapping.

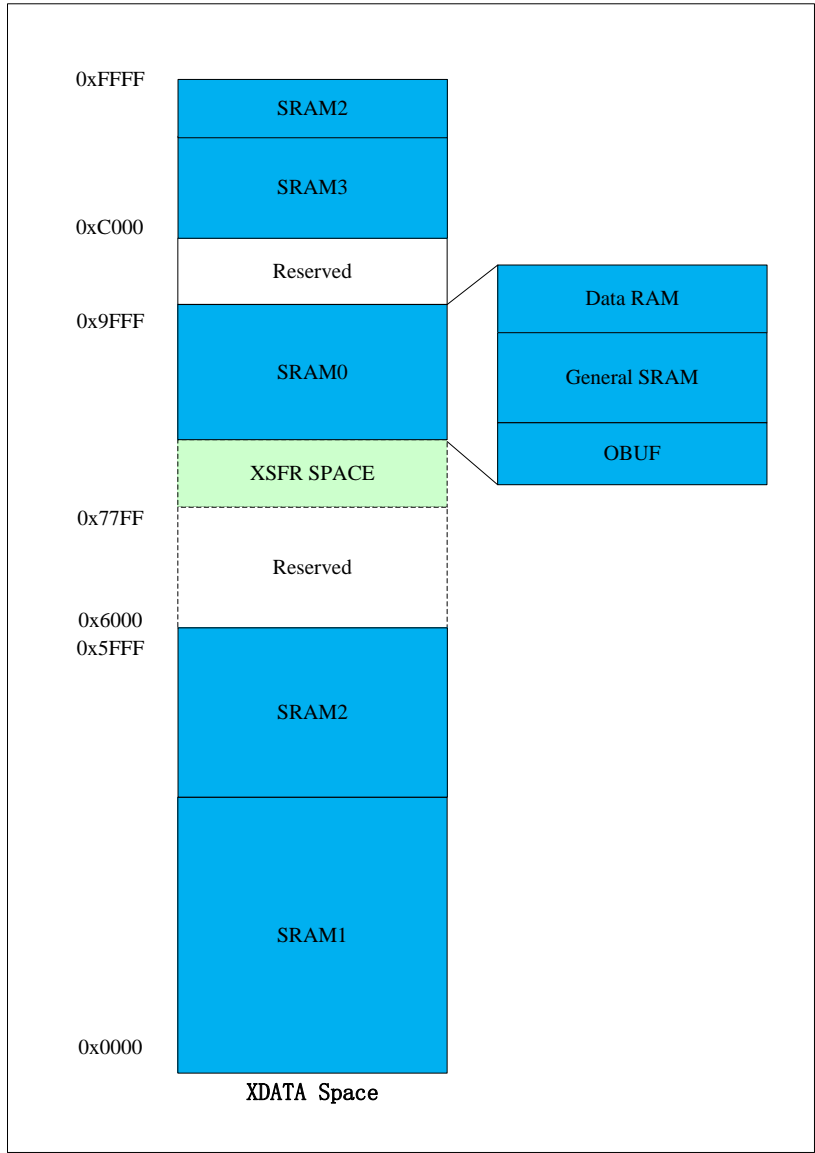

Figure 3-2 External Data Memory Mapping

3.3.3 Internal Data Memory Mapping

Internal data memory is located in SRAM0 at the address from 0x9F00 to 0x9FFF as shown in [Figure 3-2](#). Internal data memory is mapped in [Figure 3-3](#). The memory space is shown divided into three blocks, which is generally referred to as the Lower 128, the Upper 128, and SFR space.

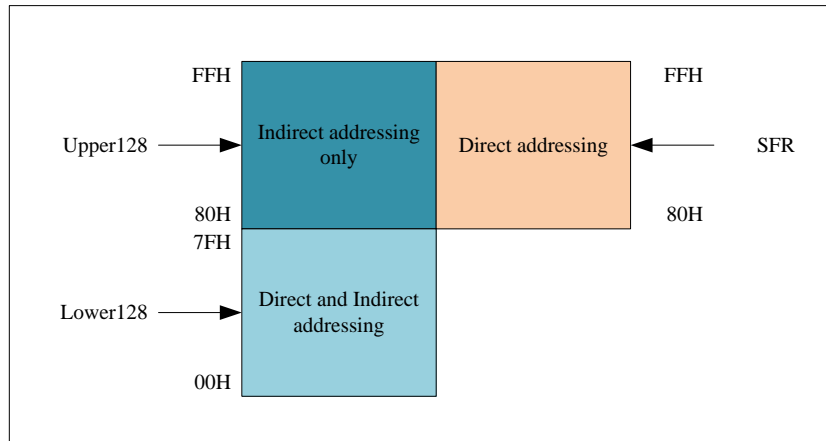

Figure 3-3 Internal data memory mapping

As shown in [Figure 3-4](#) the Lowest 32 bytes in Lower 128 are grouped into 4 banks of 8 registers. Program instructions call out these registers as R0 through R7. Two bits in the PSW select which register bank are in use.

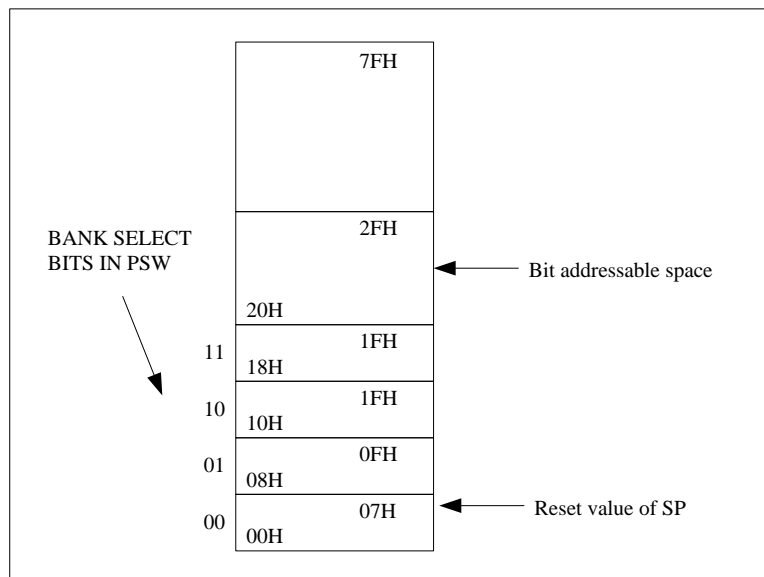

Figure 3-4 Lowest 32 bytes in Internal data memory Lower 128

3.4 Interrupt Processing

3.4.1 Interrupt sources

The CW6687B provides 15 interrupt sources. All interrupts are controlled by a series combination of individual enable bits and a global enable (EA) in the interrupt-enable register (IE0.7). Setting EA to logic 1 allows individual interrupts to be enabled. Setting EA to logic 0 disables all interrupts regardless of the individual interrupt-enable settings. The interrupt enables and priorities are functionally identical to those of the 80C52.

The CW6687B provides 3 sets of vectors entry addresses, starting from 0x0003, 0x4003 and 0x8003. The vector base address is set by DPCON [7:6]. [Table 3-2](#) lists the interrupt summary.

Table 3-2 Interrupt Summary

Interrupt Sources	Interrupt Vector	Interrupt Number	Natural Order	Interrupt Flag	Interrupt Enable Bit	Priority Control Bit
SINT0	0x0003 0x4003 0x8003	0	1	SPMODE.7	IE0.0	IPH0.0 IPO.0
SINT1 AGC	0x000B 0x400B 0x800B	1	2	SPMODE.6 AGCDMACON.0	IE0.1	IPH0.1 IPO.1
Timer 1	0x0013 0x4013 0x8013	2	3	TMR1CON.7 TMR1CON.6	IE0.2	IPH0.2 IPO.2
Timer 2	0x001B 0x401B 0x801B	3	4	TMR2CON.7 TMR2CON.6	IE0.3	IPH0.3 IPO.3
MP3/FFT1	0x0023 0x4023 0x8023	4	5	AUCON7.6 AUCON7.5 AUCON7.4 AUCON7.3 AUCON7.2 AUCON7.1 AUCON7.0 AUCON11.6 FFT1CON1.1	IE0.4	IPH0.4 IPO.4
Huffman/ UART1 (overflow)	0x002B 0x402B 0x802B	5	6	HFMCON.7 HFMCON.6 UART1STA.1	IE0.5	IPH0.5 IPO.5
USBSOF UART1 BTRAM	0x0033 0x4033 0x8033	6	7	USBCON2.1 UART1STA.3&UART1STA2 BTRAM_CON0[6]& BTRAM_CON1[4]	IE0.6	IPH0.6 IPO.6
USBCTL	0x003B 0x403B 0x803B	7	8		IE1.0	IPH1.0 IP1.0
SDC	0x0043 0x4043 0x8043	8	9	SDCON1.5 SDCON1.4	IE1.1	IPH1.1 IP1.1
PORT	0x004B 0x404B 0x804B	9	10	WKPND	IE1.2	IPH1.2 IP1.2
SPI0	0x0053 0x4053 0x8053	10	11	SPI0CON.7	IE1.3	IPH1.3 IP1.3
Timer 3	0x005B	11	12	TMR3CON.7	IE1.4	IPH1.4

Interrupt Sources	Interrupt Vector	Interrupt Number	Natural Order	Interrupt Flag	Interrupt Enable Bit	Priority Control Bit
	0x405B 0x805B					IP1.4
Timer 0	0x0063 0x4063 0x8063	12	13	TMR0CON.7 IIS_CON2.3&IIS_CON2.1	IE1.5	IPH1.5 IP1.5
RTCC UART0 WDT LVD IIS	0x006B 0x406B 0x806B	13	14	RTCON.7 UARTSTA.5&UARTSTA.4 IP0.7 LVDCON.7 IIS_CON2.3&IIS_CON2.2& IIS_CON2.1&IIS_CON2.0	IE1.6	IPH1.6 IP1.6
SPI1	0x0073 0x4073 0x8073	14	15	SPI1CON.7	IE1.7	IPH1.7 IP1.7

3.4.2 Interrupt Priority

There are 4 levels of interrupt priority: Level 3 to 0. All interrupts have individual priority bits in the interrupt priority registers that allow each interrupt to be assigned a priority level from 3 to 0. All interrupts also have a natural hierarchy. In this manner, when a set of interrupts has been assigned the same priority, a second hierarchy determines which interrupt is allowed to take precedence. The natural hierarchy is determined by analyzing potential interrupts in a sequential manner with the order listed in [Table 3-2](#).

The processor indicates that an interrupt condition occurred by setting the respective flag bit. This bit is set regardless of whether the interrupt is enabled or disabled.

3.5 Special Function Register Mapping (SFR)

Table 3-3 Special function registers naming and address

	0	1	2	3	4	5	6	7
0x80	P0	SP	DPL0	DPH0	DPL1	DPH1	DPCON	PCON0
0x88	SDCON0	SDCON1	SDCON2	MEMCON	ATDAT	ERABYT0	/	ERABYT1
0x90	P1	BFBYTEPTL	BFBYTEPTRH	BFDATAL	BFDATAH	BFBITPTR	BFCON	PCON3
0x98	PWKEN	PWKEDGE	PIE0	SPH	PCON1	ISDCHSUM	IRTCDAT	IRTCN
0xA0	P2	IIS_CON2	SPI1CON	SPI1BUF	ATADR	SPI1DMACNT	SPI1DMASP	IRCON0
0xA8	IE0	IE1	SPI1DMACNTL	IUBPCON	HFMCON1	IRCON1	AGCCON2	SPMODE
0xB0	P3	SQRT_DATA0	SQRT_DATA1	SQRT_DATA2	ERABYT2	ERABYT3	EMIBUF	PLLCON
0xB8	IP0	IP1	P0DIR	P1DIR	P2DIR	P3DIR	ERABYT4	LVDCON
0XC0	IIS_CON0	TMR2CON0	TMR2CON1	IIS_CON1	RTCON1	SECCNT	OTP_ADR	IRAM_ADR
0XC8	HFMCON	USBCON0	USBCON1	USBCON2	USBDATA	USBADR	OIRAMCNT	OIRAMCON
0XD0	PSW	HFMCNT	ADCCON	PCON2	ADCDATAL	ADCDATAH	COS_VALH	COS_VALL

0XD8	SPI0BUF	SPI0CON	ADCMODE	CLKCON	CLKCON1	USBDPDM	SQRT_DATA3	PBANK0
0XE0	ACC	IPH0	IPH1	AUCON0	AUCON1	AUCON2	AUCON3	AUCON4
0XE8	AUCON5	AUCON6	AUCON7	AUCON8	AUCON9	AUCON10	SQRT_CFG	COS_IDX
0XF0	B	ER0H	ER0L	ER1H	ER1L	CRCREG	CRCFIFO	WDTCON
0XF8	TMR0CON	TMR0CNT	TMR0PR	TMR0PWM	UARTSTA	UARTCON	IIS_CON3	UARTDATA

3.6 Extend Special Function Registers Mapping (XSFR)

Table 3-4 XSFR space mapping

	7	6	5	4	3	2	1	0
78D8H	AGCSETCNT	AGCSETDATA	BS_END_ADR	BS_BEGIN_ADR				
78D0H	AGCDATL	AGCDATH	AGCDMAADR	AGCDMACON	AGCCON3	AGCANLCON	AGCCON1	AGCCON0
78C8H	-	-	FFT1_SQRTL_A DDR	FFT1_SQRTH_A DDR	FFT1SCALE	FFT1_BUFL_AD DR	FFT1_BUFH_AD DR	FFT1_DATA_L_AD DR
78C0H	FFT1_DATAH_ADDR	-	IUBP3	IUBP2	IUBP1	IUBP0		
78B8H	P3PDS1	P2PDS1	P1PDS1	-	P3PDS0	P2PDS0	P1PDS0	-
78B0H	P3PUS1	P2PUS1	P1PUS1	-	P3PUS0	P2PUS0	P1PUS0	-
78A8H	AGCRDATL	AGCRDATH	AGCSAMPLEH	AGCSAMPLEL	AGCCON4	UART1CNTH	UART1CNTL	UART1POINTH
78A0H	UART1POINTL	UART1MINUS	UART1LOOPCNT	CLKCON2	ATCON10	ATCON9	FFT1CON1	FFT1CON
7898H	ATCON8	ATCON7	DCT_CFG	FIFO_BASE	FIFO_SPEED	AUCON11	KVADR	KVCON2
7890H	KVCON1	ATCON6	ATCON5	ATCON4	ATCON3	ATCON2	ATCON1	ATCON0
7888H	SPI1BAUD	UARTDIV	LFSR32_DAT3	LFSR32_DAT2	LFSR32_DAT1	LFSR32_DAT0	UARTBAUDH	UARTBAUD
7880H	IUBP	IUADR	IUDAT1	ID1	ID0	ECN	RANDOM_CNT	ADCBAUD
7878H	IISMDA_RD_PCNT1	IISMDA_RD_PC NT0	USBEP3TXADRH	USBEP3TXADRL	USBEP3RXADR H	USBEP3RXADRL	USBEP2TXADRH	USBEP2TXADRL
7870H	USBEP2RXADRH	USBEP2RXADRL	USBEP1TXADRH	USBEP1TXADRL	USBEP1RXADR H	USBEP1RXADRL	USBEP0ADRH	USBEP0ADRL
7868H	LFSR16_DAT1	LFSR16_DAT0	-	EMICON1	EMICON0		FIFO_SET	FIFO_TRT
7860H	SFB_GEN	AUCON12	TMR2PWMH	TMR2PWML	TMR2PRH	TMR2PRL	TMR2CNTH	TMR2CNTL
7858H	PLL1FRAL	PLL1FRACH	PLL1INTL	PLL1INTH	TMR1CON1	TMR1CON0	TMR3PWM	TMR3PR
7850H	TMR3CNT	TMR3CON	TMR1PWMH	TMR1PWML	TMR1PRH	TMR1PRL	TMR1CNTH	TMR1CNTL
7848H	PLL2FRAL	PLL2FRACH	PLL2INTL	PLL2INTH	PLL2CON	P3PD0	P2PD0	P1PD0
7840H	P0PD0	-	P2PU1	-	PUP3	PUP2	PUP1	PUP0
7838H	PMUXCON0	PLL1DIV	SDADCDON	IIS_WSCNT1	PMUXCON1		IIS_ADR0	IIS_REFCLK_CFG
7830H	IIS_DAT7	IIS_DAT6	IIS_DAT5	IIS_DAT4	IIS_DAT3	IIS_DAT2	IIS_DAT1	IIS_DAT0
7828H	IIS_BAUD	SPI1CON1	IIS_ALLBIT	IIS_DMA_RD_CN T1	IIS_DMA_RD_CN T0	IIS_DMA_WR_C NT1	IIS_DMA_WR_C NT0	P3DRV0
7820H	P2DRV0	P1DRV0	P0DRV0	IIS_WSCNT	SPIBAUD	SPIDMACNT	SPIDMAPTRH	SPIDMAPTRL
7818H	CRCRES1	CRCRES0	IIS_BCLK_CFG	UARTDIV	UARTDMATXC N	UARTDMARXC N	UARTDMATXPT R	UARTDMARXPT R
7810H	UART1STA	UART1DATA	UART1BAUD	UART1CON	HFMPTRH	HFMPTRL	BFEPTRH	BFEPTRL

7808H	IRTADT3	IRDAT2	IRDAT1	IRDAT0	IIS_VALBIT	SPMODE1	PIE1	PWRCON2
7800H	PWRCON1	RC_TRIM	IIS_ADR1	RC_TEST	SDDPTR	SDDCNT	SDCPTR	SDBAUD

3.7 CPU and Memory related SFR Description

Register 3-1 DPCON – Data Pointer Configure Register

Position	7	6	5	4	3	2	1	0
Name	IA		DPID0	DPID1	DPAID	DPTSLS	EINSTEN	DPSEL
Default	1	0	0	0	0	0	0	0
Access	R/W	R/W	R/W	R/W	R/W	R/W	R/W	R/W

IA: Select Interrupt Vector's Base Address

00 = Base address is 0x0003

01 = Base address is 0x4003

10 = Base address is 0x8003

11 = Base address is 0xc003

note: interrupt address is determined by SPMODE1[4]

0 = interrupt base address depend on IA

1 = interrupt base address is 0x2000

DPID0: DPTR0 increase direction control

0 = DPTR increase

1 = DPTR decrease

DPID1: DPTR1 increase direction control

0 = DPTR increase

1 = DPTR decrease

DPAID: DPTR auto increment enables

0 = Auto increment disable

1 = Auto increment enable

DPTSLS: DPSEL toggle enable

0 = DPSEL toggle disable

1 = DPSEL toggle enable

EINSTEN: Extern instruction enables

0 = Disable

1 = Enable

DPSEL: DPTR Select

0 = Active DPTR0

1 = Active DPTR1

Data Pointer Register is a 16-bit address pointer, it can split up into two registers, DPL and DPH. Data pointer register is always used as indirect addressing register.

Note: Interrupt address is determined by SPMODE1[4]

Register 3-2 DPL0 – Data Pointer Low Byte

Position	7	6	5	4	3	2	1	0
Name	DPL0							
Default	0	0	0	0	0	0	0	0
Access	R/W	R/W	R/W	R/W	R/W	R/W	R/W	R/W

Register 3-3 DPL1 – Data Pointer Low Byte

Position	7	6	5	4	3	2	1	0
Name	DPL1							
Default	0	0	0	0	0	0	0	0
Access	R/W	R/W	R/W	R/W	R/W	R/W	R/W	R/W

Register 3-4 DPH0 – Data Pointer High Byte

Position	7	6	5	4	3	2	1	0
Name	DPH0							
Default	0	0	0	0	0	0	0	0
Access	R/W	R/W	R/W	R/W	R/W	R/W	R/W	R/W

Register 3-5 DPH1 – Data Pointer High Byte

Position	7	6	5	4	3	2	1	0
Name	DPH1							
Default	0	0	0	0	0	0	0	0
Access	R/W	R/W	R/W	R/W	R/W	R/W	R/W	R/W

The data pointers (DPTR0 and DPTR1) are used to assign a memory address for the MOVX instructions. This address can point to a MOVX RAM location. Two pointers are useful when moving data from one memory area to another. The user can select the active pointer through a dedicated SFR bit (DPSEL: DPCON.0), or activate an automatic toggling feature that alters the pointer selection (DPTSL: DPCON.2). An additional feature, if selected, provides automatic incrementing or decrementing of the current DPTR.

Data pointer increment/decrement bits DPID0 (DPCON.5) and DPID1 (DPCON.4) define how the INC DPTR instruction functions in relation to the active DPTR.

The CW6687B offers a programmable option that allows any instructions related to data pointer to toggle the DPSEL bit automatically. This option is enabled by setting the toggle-select-enable bit (DPTSL) to logic 1.

Once enabled, the DPSEL bit is automatically toggled after the execution of one of the following 5 DPTR related instructions:

```

MOV A, @A+DPTR
MOVX A, @DPTR
MOVX @DPTR, A
INC DPTR
MOV DPTR, #data16

```

The CW6687B also offers a programmable option that automatically increases (or decreases) the contents of the selected data pointer by 1 after the execution of a DPTR-related instruction. The actual function (increment or decrement) is dependent on the setting of the DPAID bits. This option is enabled by setting the automatic

increment/decrement enable (DPAID: DPCON.3) to a logic 1 and is affected by one of the following 3 DPTR-related instructions.

DPTR-related instructions are:

MOVC A, @A+DPTR

MOVX A, @DPTR

MOVX @DPTR, A

Register 3-6 SP – Stack Pointer Low Byte

Position	7	6	5	4	3	2	1	0
Name	SP							
Default	0	0	0	0	0	1	1	1
Access	R/W	R/W	R/W	R/W	R/W	R/W	R/W	R/W

Register 3-7 SPH – Stack Pointer High Byte

Position	7	6	5	4	3	2	1	0
Name	SPH							
Default	0	0	1	1	1	1	1	1
Access	R/W	R/W	R/W	R/W	R/W	R/W	R/W	R/W

In a standard 8051, there is only one 8-bit stack pointer (SP). It can only use the internal 256 byte data memory as stack memory. To increase the stack space for more complex applications, CW6687B supports a 16-bit extend stack pointer, it can use both internal data RAM and the 20K byte on-chip SRAM as stack memory. There are 2 registers for stack control.

Register 3-8 PSW – Processor Status Word

Position	7	6	5	4	3	2	1	0
Name	CY	AC	EC	RS1	RS0	OV	EZ	P
Default	0	0	0	0	0	0	0	0
Access	R/W	R/W	R/W	R/W	R/W	R/W	R/W	R/W

CY: Carry Flag

AC: Auxiliary carry flag

EC: Extern instruction Carry flag

RS1, RS0: Register bank select

00 = bank0

01 = bank1

10 = bank2

11 = bank3

OV: Overflow flag

EZ: Extern instruction zero flag

P: Odd parity check of ACC

0 = There are even number of '1' bits in ACC

1 = There are odd number of '1' bits in ACC

Register 3-9 SPMODE – Special mode

Position	7	6	5	4	3	2	1	0
Name	SINT0	SINT1	PWRUP	RAM2CEM	DACRAMCEM	DECRAMCEM	IRAMCEM	IROMCEM
Default	0	0	1	1	1	1	1	1
Access	R/W	R/W	R/W	R/W	R/W	R/W	R/W	R/W

SINT0: Software 0 interrupts pending

0 = No software 0 interrupt

1 = Software 0 interrupt

SINT1: Software 1 interrupts pending

0 = No software 1 interrupt

1 = Software 1 interrupt

PWRUP: System power up flag

0 = CPU writes 0 to PWRUP.

1 = System power up or CPU writes 1 to PWRUP.

RAM2CEM: RAM2 CE mode control

0 = Always stay at 0

1 = Normal

DACRAMCEM: DAC RAM CE mode control

0 = Always stays at 0

1 = Normal

DECRAMCEM: DECRAM CE mode control

0 = Always stays at 0

1 = Normal

IRAMCEM: IRAM CE mode control

0 = Always stays at 0

1 = Normal

IROMCEM: IROM CE mode control

0 = Always stays at 0

1 = Normal

Register 3-10 SPMODE1 – Special mode 1

Position	7	6	5	4	3	2	1	0
Name	SDADCADOUTEN	SDADCDIEN	SPI1_MAP	INTADR_SEL	PAPAMODE	SPIINITMODE	SBCDEC_MEN	MP3DEC_MEN
Default					0	0	1	1
Access	R/W	R/W	R/W	R/W	RO	RO	R/W	R/W

SDADCADOUTEN: SDADC analog data out enable

0 = disable

1 = enable

SDADCDIEN: SDADC digital data input enable

0 = disable

1 = enable

SPI1_MAP: SPI1 port mapping

0 = Select P04, P05, P06

1 = Select P30, P31, P32

INTADR_SEL: interrupt address select

0 = depend on DPCON IA

1 = 0x2000

PAPAMODE: papa mode

0 = normal mode

1 = Parallel mode

SPIINITMODE: SPI Flash initial mode

0 = normal mode

1 = SPI initial mode

SBCDEC_MEN: SBC decoder module enables

0 = Disable

1 = Enable

MP3DEC_MEN: MP3 decoder module enables

0 = Disable

1 = Enable

Note: SPMODE1[1:0] register can be written to "0", but can't be written to "1" after writing "0".

Register 3-11 MEMCON – Memory Mapping Configure

Position	7	6	5	4	3	2	1	0
Name					CC1			CC0
Default	0	0	0	0	0	0	0	0
Access	WO	WO	RO	R/W	R/W	R/W	R/W	R/W

CC1: MIX_CODE3 mapping

000 = IROM01 map to address 0xc000~0xffff

001 = IROM02 map to address 0xc000~0xffff

010 = IROM03 map to address 0xc000~0xffff

011 = IROM11 map to address 0xc000~0xffff

100 = IROM12 map to address 0xc000~0xffff

101 = SRAM3/SRAM2 map to address 0xc000~0xffff

Register 3-12 IE0 – Interrupt Enable 0

Position	7	6	5	4	3	2	1	0
Name	EA	IE06	IE05	IE04	IE03	IE02	IE01	IE00
Default	0	0	0	0	0	0	0	0

Access	R/W	R/W	R/W	R/W	R/W	R/W	R/W	R/W
--------	-----	-----	-----	-----	-----	-----	-----	-----

EA: Global interrupt enable

0 = Disable

1 = Enable

IE06: USB SOF interrupt enable

0 = Disable

1 = Enable

IE05: Huffman/UART1 overflow interrupt enable

0 = Disable

1 = Enable

IE04: MP3 decoder and encoder interrupt enable

0 = Disable

1 = Enable

IE03: Timer2 interrupt enable

0 = Disable

1 = Enable

IE02: Timer1 interrupt enable

0 = Disable

1 = Enable

IE01: SINT1/AGC interrupt enable

0 = Disable

1 = Enable

IE00: SINT0 interrupt enable

0 = Disable

1 = Enable

Register 3-13 IE1 – Interrupt Enable 1

Position	7	6	5	4	3	2	1	0
Name	IE17	IE16	IE15	IE14	IE13	IE12	IE11	IE10
Default	0	0	0	0	0	0	0	0
Access	R/W	R/W	R/W	R/W	R/W	R/W	R/W	R/W

IE17: SPI1 interrupt enable

0 = Disable

1 = Enable

IE16: RTCC/UART0/UART1/LVD/WDT/IIS interrupt enable

0 = Disable

1 = Enable

IE15: Timer0 interrupt enable

0 = Disable

1 = Enable

IE14: Timer 3 interrupt enable

0 = Disable

1 = Enable

IE13: SPI interrupt enable

0 = Disable

1 = Enable

IE12: Port interrupt enable

0 = Disable

1 = Enable

IE11: SDC interrupt enable

0 = Disable

1 = Enable

IE10: USB control interrupt enable

0 = Disable

1 = Enable

Register 3-14 IPH0 – Interrupt Priority high 0

Position	7	6	5	4	3	2	1	0
Name	IPH07	IPH06	IPH05	IPH04	IPH03	IPH02	IPH01	IPH00
Default	0	0	0	0	0	0	0	0
Access	R/W	R/W	R/W	R/W	R/W	R/W	R/W	R/W

Register 3-15 IP0 – Interrupt Priority 0

Position	7	6	5	4	3	2	1	0
Name	IP07	IP06	IP05	IP04	IP03	IP02	IP01	IP00
Default	0	0	0	0	0	0	0	0
Access	R/W	R/W	R/W	R/W	R/W	R/W	R/W	R/W

IPH07, IP07: Watch Dog interrupt Priority select

11 = level 3 highest priority

10 = level 2

01 = level 1

00 = level 0 lowest priority

IPH06, IP06: USB SOF interrupts priority

11 = level 3 highest priority

10 = level 2

01 = level 1

00 = level 0 lowest priority

IPH05, IP05: Huffman interrupt priority

11 = level 3 highest priority

10 = level 2

01 = level 1

00 = level 0 lowest priority

IPH04, IP04: MP3 decoder interrupts priority

11 = level 3 highest priority

10 = level 2

01 = level 1

00 = level 0 lowest priority

IPH03, IP03: Timer2 interrupt priority

11 = level 3 highest priority

10 = level 2

01 = level 1

00 = level 0 lowest priority

IPH02, IP02: Timer1 interrupt priority

11 = level 3 highest priority

10 = level 2

01 = level 1

00 = level 0 lowest priority

IPH01, IP01: SINT1 interrupt priority

11 = level 3 highest priority

10 = level 2

01 = level 1

00 = level 0 lowest priority

IPH00, IP00: SINT0 interrupt priority

11 = level 3 highest priority

10 = level 2

01 = level 1

00 = level 0 lowest priority

Register 3-16 IPH1 – Interrupt Priority high 1

Position	7	6	5	4	3	2	1	0
Name	IPH17	IPH16	IPH15	IPH14	IPH13	IPH12	IPH11	IPH10
Default	0	0	0	0	0	0	0	0
Access	R/W	R/W	R/W	R/W	R/W	R/W	R/W	R/W

Register 3-17 IP1 – Interrupt Priority 1

Position	7	6	5	4	3	2	1	0
Name	IP17	IP16	IP15	IP14	IP13	IP12	IP11	IP10
Default	0	0	0	0	0	0	0	0
Access	R/W	R/W	R/W	R/W	R/W	R/W	R/W	R/W

IPH17, IP17: SPI1 interrupt priority

11 = level 3 highest priority

10 = level 2

01 = level 1

00 = level 0 lowest priority

IPH16, IP16: RTCC/UART/LVD/WDT/IIS interrupt priority

11 = level 3 highest priority

10 = level 2

01 = level 1

00 = level 0 lowest priority

IPH15, IP15: Timer0 interrupt priority

11 = level 3 highest priority

10 = level 2

01 = level 1

00 = level 0 lowest priority

IPH14, IP14: Timer 3 interrupts priority

11 = level 3 highest priority

10 = level 2

01 = level 1

00 = level 0 lowest priority

IPH13, IP13: SPI interrupt priority

11 = level 3 highest priority

10 = level 2

01 = level 1

00 = level 0 lowest priority

IPH12, IP12: Port interrupts priority

11 = level 3 highest priority

10 = level 2

01 = level 1

00 = level 0 lowest priority

IPH11, IP11: SDC interrupt priority

11 = level 3 highest priority

10 = level 2

01 = level 1

00 = level 0 lowest priority

IPH10, IP10: USB control interrupts priority

11 = level 3 highest priority

10 = level 2

01 = level 1

00 = level 0 lowest priority

3.8 CPU breakpoint

CPU breakpoint interrupt address is 0x207b, when breakpoint takes place, the current instruction will be executed.

Register 3-1 IUBPCON –Breakpoint control Register

Position	7	6	5	4	3	2	1	0
Name	BP3_PND	BP2_PND	BP1_PND	BP0_PND	BP3_EN	BP2_EN	BP1_EN	BP0_EN
Default	0	0	0	0	0	0	0	0
Access	R/W	R/W	R/W	R/W	R/W	R/W	R/W	R/W

BP3_PND: Breakpoint 3 pending

When read:

0 = no BP3 take place

1 = BP3 take place

When write 0 clear this pending; write 1 affect nothing

BP2_PND: Breakpoint 2 pending

When read:

0 = no BP2 take place

1 = BP2 take place

When write 0 clear this pending; write 1 affect nothing

BP1_PND: Breakpoint 1 pending

When read:

0 = no BP1 take place

1 = BP1 take place

When write 0 clear this pending; write 1 affect nothing

BP0_PND: Breakpoint 0 pending

When read:

0 = no BP0 take place

1 = BP0 take place

When write 0 clear this pending; write 1 affect nothing

BP3_EN; Breakpoint 3 enable

0 = disable

1 = enable

BP2_EN; Breakpoint 2 enable

0 = disable

1 = enable

BP1_EN; Breakpoint 1 enable

0 = disable

1 = enable

BP0_EN; Breakpoint 0 enable

0 = disable

1 = enable

Register 3-1 IUBP0–Breakpoint 0 address Register

Position	7	6	5	4	3	2	1	0
Name	IUBP0							
Default	0	0	0	0	0	0	0	0
Access	R/W	R/W	R/W	R/W	R/W	R/W	R/W	R/W

Breakpoint 0 address, should configure this register twice, first is high address, second is low address.

Register 3-1 IUBP1–Breakpoint 1 address Register

Position	7	6	5	4	3	2	1	0
Name	IUBP1							
Default	0	0	0	0	0	0	0	0
Access	R/W	R/W	R/W	R/W	R/W	R/W	R/W	R/W

Breakpoint 1 address, should configure this register twice, first is high address, second is low address.

Register 3-1 IUBP2–Breakpoint 2 address Register

Position	7	6	5	4	3	2	1	0
Name	IUBP2							
Default	0	0	0	0	0	0	0	0
Access	R/W	R/W	R/W	R/W	R/W	R/W	R/W	R/W

Breakpoint 2 address, should configure this register twice, first is high address, second is low address.

Register 3-1 IUBP3–Breakpoint 3 address Register

Position	7	6	5	4	3	2	1	0
Name	IUBP3							
Default	0	0	0	0	0	0	0	0
Access	R/W	R/W	R/W	R/W	R/W	R/W	R/W	R/W

Breakpoint 3 address, should configure this register twice, first is high address, second is low address

4 Reset Generation

4.1 Power-on Reset (POR)

CW6687B provides an on-chip Power-On-Reset (POR) circuit to detect power-on and reset internal logic before VDD reaches the pre-determined POR threshold voltage. When VDD=1.2V, the POR threshold voltage is set around about 0.9V~1.5V.

Sometimes, when the VDD is powered-off and quickly powered-on again, there might be times when POR will not work smoothly and internal reset might not be generated. For this reason, CW6687B POR circuit incorporates an internal self-reset module to discharge PORB output during power-off to ensure each power cycle will work properly.

However, it is still highly recommended for users to allow a suitable amount of time to pass before powering on after powering off, to ensure a successful start-up. The time depends on the actual system board environment and how many decoupling capacitors are between power and ground. The user has to take into account this effect during board level design.

Figure 4-1 illustrates the power-on and reset signals waveform during proper power-on. Internally, there is TPOR and TRC time for both the POR circuit and the internal counter. TPOR is the time for the POR circuit to stay at zero voltage until it reaches VPOR and the time varies for different VDD rise-up time. It should be around 2/3 of the VDD rise-up times. When the counter receives a high logic from the PORB signal, it is time for the internal counter to count 4ms through the internal RC-oscillator, which is TRC. As a result, the overall internal reset time is the sum of TPOR and TRC. Such a long time is required to ensure the Power is stable for system use. It also ensures all internal logics are properly reset.

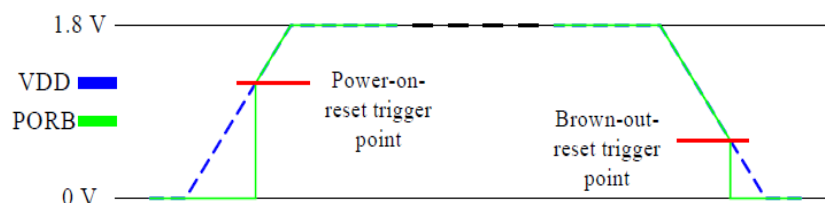

Figure 4-1 Power on reset

4.2 System Reset

All reset signals are OR'ed together inside the device to generate an overall system reset to reset the chip. Once reset, the program memory address is reset to 8000h, which is the start address of the Normal Mode. *Figure 4-2* illustrates the reset sources.

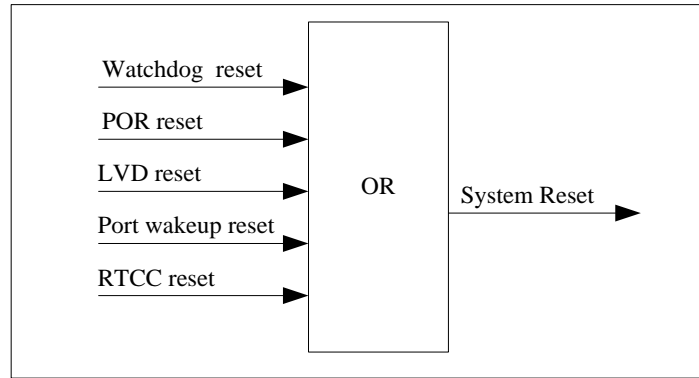

Figure 4-2 Reset Sources

4.2.1 LVD

CW6687B provides 4 levels programmable Low Voltage Detector (LVD) for user to detect VDDLDO power supply voltage or external pin voltage multiplexed with GPIO P2.2. This is because VDDLDO is the input voltage source for on-chip Low-Drop-Out regulator (LDO) which supplies power to internal VDDCORE. Hence, users can momentarily monitor the VDDLDO power if it's externally connected to some batteries and for detection if the external power source starts dropping to a level that CW6687B LDO can neither tolerate nor perform properly in the system program.

LVD can also be used to monitor external voltage source through the GPIO P2.2 to enhance programmability for different voltage levels. One example of this is it can be used to monitor external power sources or batteries voltage or some voltages related to say pressure or temperature. It is there to provide a simple interface compared to ADC since ADC requires more programming space and procedures to detect precise voltage level in detail. If the user requires general voltage detection without fine voltage range, LVD will be a good choice compared to ADC measurement. *Table 4-1* illustrates different voltage detection levels.

Remark:

- When LVD_ENB is enabled, there is approximately 100us for the band-gap and the comparator to be stable before the end-user can use it as low voltage detection. During the time, LVD_OEB has to be H in order to disable the LVD output which possibly fluctuates signal level.
- Different power supply falling times will affect the voltage detection. It is recommended that the power supply falling time should be larger than 1ms for stable low voltage detection.

When detection occurs, interrupt can be generated if LVD interrupt is enabled, or, CW6687B can undergo reset if interrupt is disabled.

Note that the detection is slightly dependent on power supply's falling rate and during power drop, noise fluctuation may alter the detection results. For this reason, internally the comparator has about 150mV hysteresis voltage level defined as $V_{HYS} = VLVD_{R} - VLVD_{S}$ to filter out any noise that may occur. Also, the detection level may have a maximum of 100mV difference compared to the value stated in [Table 4-1](#)

Table 4-1 LVD level setting

BORS[3:0]	Detected VDDLDO V	BORS[3:0]	Detected VDDLDO V
4'b0000	2.200	4'b1000	3.267

BORS[3:0]	Detected VDDLDO V	BORS[3:0]	Detected VDDLDO V
4'b0001	2.333	4'b1001	3.400
4'b0010	2.467	4'b1010	3.533
4'b0011	2.600	4'b1011	3.667
4'b0100	2.733	4'b1100	3.800
4'b0101	2.867	4'b1101	3.933
4'b0110	3.000	4'b1110	4.067
4'b0111	3.133	4'b1111	4.200

For an ideal operation, it is recommended to perform the following for LVD.

1. Select either VDDLDO or external pin to be monitored. Set VD1_ENB = 0 for VDDLDO or VD2_ENB = 0 for external pin
2. Select the detection voltage by setting bits BORS[3:0]
3. Enable the LVD by setting LVD_ENB = 0
4. Wait for at least 30us for the internal band-gap and comparator to become stable
5. Enable the LVD output by setting LVD_OEB = 0
6. The EX_PIN detect voltage must be less than VDDIO

Register 4-1 LVDCON– LVD control

Position	7	6	5	4	3	2	1	0
Name	LVDIF	LVDRSTEN		LVDOE				
Default	0	1	0	0	1	0	0	0
Access	R/W	R/W	R/W	R/W	R/W	R/W	R/W	R/W

LVDIF: LVD interrupt pending bit.

0 = When LVD threshold not detect. Cleared by writing a 0 to it

1 = When LVD threshold is detected

LVD_RSTEN: LVD Reset enable bit. Low active

0 = LVD Reset is disabled

1 = LVD is enabled

LVD_EN: LVD enable bit. Low active

0 = LVD is enabled

1 = LVD is disabled

LVD_OE: LVD output enable bit. Low active

0 = LVD output is enabled

1 = LVD output is disabled

VD2_EN: External pin (P0.0) voltage enable bit. Low active

0 = External pin voltage detection is enabled

1 = External pin voltage detection is disabled

VD1_EN: VDDLDO voltage enable bit. Low active

0 = VDDLDO voltage detection is enabled

1 = VDDLDO voltage detection is disabled

LVDS: Voltage detection level select

00 = 2.2V/1.2V

01 = 2.4V/1.95V

10 = 2.7V/2.2V

11 = 3.1V/2.5V

4.2.2 RTCC Reset

CW6687B can be reset by RTCC second and alarm interrupt when IRTRSTEN bit in RTCON is set to 1.

4.2.3 Watchdog Reset

If Watchdog timer is enabled, and WDTCON [5] is not written by 1 within watchdog overflow time period, CW6687B will be reset by Watchdog overflow.

4.2.4 Port Wakeup Reset

During SLEEP mode, port wakeup event will cause CW6687B to reset.

4.3 Clock System

4.3.1 Clock Control

CW6687B embeds 32K/4M/12M/24M OSC internal oscillator circuits. External crystal is needed to generate a clock source. One internal PLL can generate 48MHz from the crystal clock source. One internal RC oscillator is also embedded.

To make sure the USB module operates properly, the USB clock must be set to 48MHz. In this case, system clock can be 48 MHz or 24MHz.

Register 4-2 PCON0 – Power control 0

Position	7	6	5	4	3	2	1	0
Name	DRAMCEN	IRAMCEN	IROMCEN	RAM2CEN	IRCEN	IDLE	HOLD	SLEEP
Default	0	0	0	0	0	0	0	0
Access	R/W	R/W	R/W	R/W	R/W	R/W	R/W	R/W

DRAMCEN: DECRAM clock enable

0 = Enable

1 = Disable

IRAMCEN: IRAM clock enable

0 = Enable

1 = Disable

IROMCEN: IROM clock enable

0 = Enable

1 = Disable

RAM2CEN: RAM2 clock enable

0 = Enable

1 = Disable

IRCNEN: IR clock enable

0 = Enable

1 = Disable

IDLE: IDLE mode

0 = Disable

1 = Enable IDLE mode

HOLD: HOLD mode

0 = Disable

1 = Enable HOLD mode

SLEEP: SLEEP mode

0 = Disable

1 = Enable SLEEP mode

Register 4-3 PCON1 – Power control 1

Position	7	6	5	4	3	2	1	0
Name	DACCEN	MP3CEN	IISCEN	TMRCEN	UARTCEN	SDCCEN	FFTCEN	SPICEN
Default	1	0	0	0	0	0	1	0
Access	R/W	R/W	R/W	R/W	R/W	R/W	R/W	R/W

DACCEN: DAC clock enable

0 = Enable

1 = Disable

MP3CEN: MP3 decoder clock enable

0 = Enable

1 = Disable

IISCEN: IIS clock enable

0 = Enable

1 = Disable

TMRCEN: Timer clock enable

0 = Enable

1 = Disable

UARTCEN: UART clock enable

0 = Enable

1 = Disable

SDCCEN: SDC clock enable

0 = Enable

1 = Disable

FFTCEN: FFT/IFFT clock enable

0 = Enable

1 = Disable

SPICEN: SPI clock enable

0 = Enable

1 = Disable

Register 4-4 PCON2 – Power control 2

Position	7	6	5	4	3	2	1	0
Name	IROM1CEN	USBCEN	TSCLK_OUT_EN	EMICEN	RTCCEN	WDTCEN	LVDCEN	ADCCEN
Default	0	0	0	0	0	0	0	0
Access	R/W	R/W	R/W	R/W	R/W	R/W	R/W	R/W

IROM1CEN: IROM1 clock enable

0 = Enable

1 = Disable

USBCEN: USB clock enable

0 = Enable

1 = Disable

TSCLK_OUT_EN: RC or PLL clock output enables

0 = Disable

1 = Enable

EMICEN: EMI clock enable

0 = Enable

1 = Disable

RTCCEN: RTCC clock enable

0 = Enable

1 = Disable

WDTCEN: WDT clock enable

0 = Enable

1 = Disable

LVDCEN: LVD clock enable

0 = Enable

1 = Disable

ADCCEN: ADC clock enable

0 = Enable

1 = Disable

Register 4-5 PCON3 – Power control 3

Position	7	6	5	4	3	2	1	0
Name	XOSC32KEN	XOSC12MEN	BASSCEN	AUALUEN	FMAMCEN	AGCEN	RCEN	SYS_PLL_SEL
Default	0	0	1	1	1	1	1	0

Access	R/W	R/W	R/W	R/W	R/W	R/W	R/W	R/W
--------	-----	-----	-----	-----	-----	-----	-----	-----

XOSC32KEN: XOSC 32K enable

0 = Disable

1 = Enable

XOSC12MEN: XOSC 12M enable

0 = Disable

1 = Enable

BASSCEN: Bass clock enable

0 = Enable

1 = Disable

AUALUEN: Audio clock enable

0 = Disable

1 = Enable

FMAMCEN: FMAM clock enable

0 = Enable

1 = Disable

AGCEN: AGC clock enable

0 = Enable

1 = Disable

RCEN: RC enable bit

0 = Disable

1 = Enable

SYS_PLL_SEL: system PLL clock select

0 = PLL1 48MHz

1 = PLL2 49.152 MHz

Register 4-6 PCON4 – Power control 4

Position	7	6	5	4	3	2	1	0
Name		BTPLL_EN	BTRAMCEN	MP3ECEN	WMACEN	APECEN	AECRCEN	AECCEN
Default	0	0	0	0	0	0	0	0
Access	R/W	R/W	R/W	R/W	R/W	R/W	R/W	R/W

BTPLL_EN: BT PLL enable

0 = Enable

1 = Disable

BTRAMCEN: BTRAM control clock enable

0 = Enable

1 = Disable

MP3ECEN: MP3 encoder clock enable

0 = Enable

1 = Disable

WMACEN: WMA decoder clock enable

0 = Enable

1 = Disable

APECEN: APE decoder clock enable

0 = Enable

1 = Disable

AECRCEN: AEC ram clock enable

0 = Enable

1 = Disable

AECCEN: AEC clock enable

0 = Enable

1 = Disable

Register 4-7 PCON5 – Power control 5

Position	7	6	5	4	3	2	1	0
Name	MP3_LP_EN	VDDIOLDO_UNSNIFF	SBUCKEN	SWPD_EN	PSWPD			
Default	0	0	0	0	0	0	0	0
Access	R/W	R/W	R/W	R/W	R/W	R/W	R/W	R/W

MP3_LP_EN: MP3 enter low power

0 = exit low power mode

1 = enter low power mode

VDDIOLDO_UNSNIFF: VDDIO LDO unsniff enable

0 = Enable

1 = Disable

SBUCKEN: Sniff BUCK enable

0 = Enable

1 = Disable

SWPDEN: enable

0 = Enable

1 = Disable

PSWPD:

0 = Enable

1 = Disable

Register 4-8 PCON6 – Power control 6

Position	7	6	5	4	3	2	1	0
Name							LPWK_TMRSEL	
Default	0	0	0	0	0	0	0	0
Access	R/W	R/W	R/W	R/W	R/W	R/W	R/W	R/W

LPWK_TMR_SEL: low power wake up time selection

00 = 256 X system clock

01 = 128 X system clock

10 = 16 X system clock

11 = 2 X system clock

1 = enter low power mode

Register 4-9 CLKCON – Clock control

Position	7	6	5	4	3	2	1	0
Name	Reserved	RCSEL		WDTCSSEL	RTCCS		SCSEL	
Default	0	0	0	0	0	0	0	0
Access	R/W	R/W	R/W	R/W	R/W	R/W	R/W	R/W

RCSEL: RC frequency select

00 = RC 512K

01 = RC 32K

10 = RC 1M

11 = RC 4M or XOSC26M controlled by CLKCON2[3]

WDTCSSEL: WDT clock section

0 = Internal 32 KHz RC oscillator output

1 = External 32 KHz or 12MHz crystal oscillator controlled by CLKCON2 [6] and CLKCON2 [7]

RTCCS: RTCC clock source select

00 = External 32 KHz or 12MHz crystal oscillator controlled by CLKCON2 [6] and CLKCON2 [7]

01 = Internal 32 KHz RC oscillator output

10 = Select 32 KHz clock source derived from external 12MHz crystal oscillator

11 = Reserve

SCSEL: System clock select

00 = Internal 512 KHz RC oscillator output

01 = External 32 KHz or 12MHz crystal oscillator controlled by PCON3 [5]

10 = PLL 48/24/16/12 MHz output, controlled by CLKCON1 [1:0]

11 = Reserve

Register 4-10 CLKCON1 – Clock control 1

Position	7	6	5	4	3	2	1	0
Name	ATCLKSEL		BTPLL_SEL	DECDIV	SYSDIV		PLLDIVSEL	
Default	0	0	0	0	0	0	0	0
Access	R/W	R/W	R/W	R/W	R/W	R/W	R/W	R/W

ATCLKSEL: Audio clock select

00 = Select external 12MHz crystal oscillator invert

01 = Select external 12MHz crystal oscillator

10 = Select PLL 24MHz output invert

11 = Select PLL 24MHz output

BTPLL_SEL: BT PLL output 48M selection

0 = not select BT PLL

1 = Select BT PLL 48M as system PLL and DAC PLL

DECDIV: Decoder clock divide 2 from system clock

0 = Disable

1 = Enable

SYSDIV: System clock divide from clock source

00 = System clock source

01 = Divided by 2 from system clock source

10 = Divided by 4 from system clock source

11 = Divided by 8 from system clock source

PLLDIVSEL: PLL output divide select

00 = Select 48MHz output

01 = Select 24MHz output

10 = Select 16MHz output

11 = Select 12MHz output

Register 4-11 CLKCON2 – Clock control 2

Position	7	6	5	4	3	2	1	0
Name	IISREFCSEL		IISBCSEL		TSCLK_OUT_SEL	IR32K_SEL	IR_CLK_SEL	
Default	0	0	0	0	0	0	0	0
Access	R/W	R/W	R/W	R/W	R/W	R/W	R/W	R/W

IISREFCSEL: IIS Reference clock source select

00 = Select system clock

01 = Select XOSC12M

10 = Select PLL2

11 = Select PLL2 div2

IISBCSEL: IIS BCLK generate clock source select

00 = Select system clock

01 = Select external 12MHz crystal oscillator

01 = Select PLL2

11 = Select PLL2 div2

TSCLK_OUT_SEL: RC or PLL clock output select

0 = RC clock output

1 = 26MHz XOSC from BT

IR32K_SEL: IR digital model work at 32K clock

0 = Work at 1M clock

1 = Work at 32K clock

IR_CLK_SEL: ir_clk sel divide select

00 = 1MHz PLL

01 = 1MHz RC

10 = External 32 KHz or 12MHz crystal oscillator controlled by CLKCON2 [6] and CLKCON2 [7] as shown in

11 = 1MHz div form XOSC26M

4.3.2 Operation Guide

User guide 1:

CW6687B integrates a 4M RC clock called RC4M, extern OSC 26MHz, extern OSC 32K or 12MHz

4.3.3 Clock Gating

CW6687B provides comprehensive clock gating options for eliminating power-wasting activities. System clock supplies clock signal to different clock domains. Every clock can be gated. It allows the user to shut down the clock signal when the function is not needed.

4.3.4 Phase Lock Loop (PLL)

CW6687B provides one on-chip Phase Locked Loop (PLL 48M) clock generators. The PLL has a reference clock from external 32 KHz/4M/12 M crystal oscillators to provide a stable reference clock, and the reference clock is multiplied to provide the final PLL output.

Register 4-12 PLLCON – PLL Configuration

Position	7	6	5	4	3	2	1	0
Name	SDADCLKEN	PLLTCLKSEL	SDADCCLK_SEL		PLL12DREF_SEL		PLL1 DREF_SEL	
Default	0	0	0	0	0	0	0	0
Access	R/W	R/W	R/W	R/W	R/W	R/W	R/W	R/W

PLL1AREF_SEL: PLL1 input reference clock digital select

00 = XOSC

01 = RCOSC

10 = RCOSC div

11 = Reserved

PLL2AREF_SEL: PLL2 input reference clock digital select

00 = XOSC

01 = RCOSC

10 = PLL1 div

11 = Reserved

SDADCCLK_SEL: SDADC clock select

00 = XOSC inv

01 = XOSC

10 = PLL2 div2 inv

11 = PLL2

PLLTCLKSEL: PLL digital test clock select enable

0 = disable

1 = enable

SDADCEN: SDADC clock enable

0 = disable

1 = enable

Register 4-13 PLL1CON – PLL1 Configuration

Position	7	6	5	4	3	2	1	0
Name	Reserved	Reserved	PLL1 AREF_SEL		X12EN	PLL1DEN32K	PLL1DEN	PLL1AEN
Default	0	0	0	0	0	0	0	0
Access	R/W	R/W	R/W	R/W	R/W	R/W	R/W	R/W

PLL1AEN: PLL analog module enables

0 = Disable

1 = Enable

PLL1DEN: PLL digital module enables

0 = Disable

1 = Enable

When change the divider, also need write 1 to PLLDEN

PLL1DEN32K: PLL digital 32K enable

0 = disable

1 = enable

X12EN: XOSC 12M 374 divider enable bit

0 = Disable

1 = Enable

PLL1AREF_SEL: PLL input reference clock analog select

00 = 12M XOSC

01 = 4M XOSC

10 = 32K XOSC

11 = 32K XOSC

Register 4-14 PLL1DIV – PLL1 clock div for PLL2

Position	7	6	5	4	3	2	1	0
Name	PLL1DIV							
Default	0	0	0	0	0	0	0	0
Access	R/W	R/W	R/W	R/W	R/W	R/W	R/W	R/W

PLL1DIV Clock = 48MH/PLL1DIV;

Register 4-15 PLL1INT – PLL1 integer low

Position	7	6	5	4	3	2	1	0
Name	PLL1INT							
Default	0	0	1	0	0	1	1	1
Access	R/W	R/W	R/W	R/W	R/W	R/W	R/W	R/W

PLL1INT = int (60MHz/pll1_refclock)

Register 4-16 PLL1FRACH – PLL1 fraction high

Position	7	6	5	4	3	2	1	0
Name	FRACH							
Default	0	0	0	0	0	0	0	0
Access	R/W	R/W	R/W	R/W	R/W	R/W	R/W	R/W

Register 4-17 PLL1FRACL – PLL1 fraction low

Position	7	6	5	4	3	2	1	0
Name	FRACL							
Default	0	0	0	0	0	0	0	0
Access	R/W	R/W	R/W	R/W	R/W	R/W	R/W	R/W

When the fraction is less than 0.25, set FOVER to =1, and fraction = (fraction+1)/2, integer = (integer-1)

When the fraction is greater than 0.80, set FOVER to=1, and fraction = fraction/2, integer = integer

FRAC = fraction*65535;

Register 4-18 PLL2CON – PLL2 Configuration

Position	7	6	5	4	3	2	1	0
Name	Reserved	PLL2TSEL	PLL2 AREF_SEL		PLL1_DIVEN	PLL2DEN32K	PLL2DEN	PLL2AEN
Default	0	0	1	0	0	1	0	0
Access	R/W	R/W	R/W	R/W	R/W	R/W	R/W	R/W

PLL2AEN: PLL2 analog module enables

0 = Disable

1 = Enable

PLL2DEN: PLL2 digital module enables

0 = Disable

1 = Enable

When change the divider, also need write 1 to PLL2DEN

PLL2DEN32K: PLL2 digital 32K enable

0 = disable

1 = enable

PLL1_DIVEN: PLL1 divide enable

0 = disable

1 = enable

PLL2AREF_SEL: PLL2 input reference clock analog select

00 = 12M XOSC

01 = 4M XOSC

10 = 32K XOSC

11 = 32K XOSC

PLL2TSEL: PLL2 test select

0 = PLL2 refclock output

1 = PLL2 fbclock output

Register 4-19 PLL2INTH – PLL2 integer high

Position	7	6	5	4	3	2	1	0
Name	PLL2INT[11:8]							
Default	0	0	0	0	1	0	1	1
Access	R/W	R/W	R/W	R/W	R/W	R/W	R/W	R/W

Register 4-20 PLL2INTL – PLL2 integer low

Position	7	6	5	4	3	2	1	0
Name	PLL2INT[7:0]							
Default	1	0	1	0	1	0	0	0
Access	R/W	R/W	R/W	R/W	R/W	R/W	R/W	R/W

$PLL2INT = \text{int}(98.304\text{MHz}/\text{pll2_refclock})$

Register 4-21 PLL2FRACH – PLL2 fraction high

Position	7	6	5	4	3	2	1	0
Name	FRACH							
Default	0	0	0	0	0	0	0	0
Access	R/W	R/W	R/W	R/W	R/W	R/W	R/W	R/W

Register 4-22 PLL2FRACL – PLL2 fraction low

Position	7	6	5	4	3	2	1	0
Name	FRACL							
Default	0	0	0	0	0	0	0	0
Access	R/W	R/W	R/W	R/W	R/W	R/W	R/W	R/W

When the fraction is less than 0.25, set FOVER=1, and fraction = (fraction+1)/2, integer = (integer-1)

When the fraction is more than 0.80, set FOVER=1, and fraction = fraction/2, integer = integer

$FRAC = \text{fraction} * 65535$

User's guide:

1. PLL1 frequency division

a) PLL1's:

-input reference clock is f0 (from RC or OSC)

-internal dividing clock is 60M

-frequency dividing ratio is $60M/f_0$.

b)

Clock divide ratio consists of integer and decimal

-default value of integer part is 1831(default reference clock is 32.768k)

-default value of decimal part is 0(only integral frequency division this time).

c)

If $f_0=32.768k$, frequency dividing ratio is 1831, decimal fraction part set 0.

If $f_0=12M$, frequency dividing ratio is 5, decimal fraction part set 0.

If $f_0=4M$, frequency dividing ratio is 15, decimal fraction part set 0.

2. If frequency dividing ratio is 58.a, then integer set 58, decimal fraction is $a*65535$.
3. PLL2 same as PLL1

5 Low Power Management

5.1 Power Saving Mode

CW6687B device offers low power management mode that helps reduce power consumption when the device does not require intensive CPU resources and speed. There are four low power modes available: SLEEP mode, Hold mode, IDLE mode and power down mode.

5.1.1 Sleep Mode

SLEEP mode is an ultimate power reduction mode that will stop all the clock sources, and all the memory chip select signals are disabled to further reduce power consumption. However, before entering sleep mode, all peripherals should be disabled separately, especially those analog peripherals and memory, unless those peripherals will stop themselves if no clock source is applied to the peripherals.

Note: Before Entering SLEEP mode, the system clock is recommended to change back to oscillator clock as the system clock.

To enter SLEEP mode, the user needs to write a '1' to SLEEP register (Bit0 of PCON0).

During SLEEP mode, the device can perform wake up by external port wakeup reset, watchdog reset or RTCC reset.

After exit SLEEP mode by wakeup, the device will be reset.

SLEEP mode will enable DEGRAM, and IRAM and system clock automatically.

5.1.2 Hold Mode

HOLD mode will stop the clock from entering the system. The system clock is gated with the HOLD mode control. Once enter HOLD mode, clock to the system logic halts. Therefore, there will be no clock switching entering the system logic, minimizing power usage due to the absence of AC switching. However, the clock sources are not disabled and they are still running. This allows the clock to be resumed in real time without waiting for the PLL to lock again. Watchdog interrupt, RTCC interrupt, Port interrupt and all reset event will cause system to exit HOLD mode.

TO enter HOLD mode, the user needs to write a '1' to HOLD register (Bit1 of PCON0).

During wakeup from HOLD Mode by port or RTCC with interrupt enabled, CW6687B enters corresponding interrupt service subroutine (ISR), else CW6687B will execute the instruction following HOLD.

During wakeup from HOLD Mode by watchdog with watchdog reset enabled, CW6687B will be reset, else if watchdog interrupt is enabled, CW6687B will enter watchdog's ISR. Otherwise, CW6687B will execute the instruction following HOLD.

5.1.3 Idle Mode

IDLE mode will stop the clock from entering to the CPU. The CPU clock is gated with the IDLE mode control. Once you enter IDLE mode, the clock to the CPU logic will stop. Therefore, there will be no clock switching entering the CPU logic so CPU power consumption is minimized.

All interrupt sources will cause system to exit IDLE mode, which includes all peripheral interrupt.

TO enter IDLE mode, user need to write a '1' to IDLE register (Bit2 of PCON0).

Upon exiting IDLE mode, CW6687B will enter interrupt service subroutine if EA is enabled. If EA is disabled, the instruction next to IDLE will be executed.

5.1.4 Power Down Mode

Power Down mode will disable core 1.2V and VDDIO 3.3V power, so all the IO state, RAM, OTP, MROM and logic (except for IRTCC) will be powered off. The content in RAM and logic disappears, should be initial after wake up.

Enter power down mode:

- 1) Disable the entire analog model
- 2) Select wake up source in WK_EN
- 3) Disable RC, RVDD, VDD1P8, VDD3P3, PMU, in PWRCON (RTC power field); RCEN, RVDD_EN, DVDD_EN, VDDIO_EN, PMU_EN

Power down mode wake up source:

- 1) RTC alarm wake up
- 2) RTC WKO pin wake up
- 3) RTC every minute wake up
- 4) RTC every day wake up

NOTE: After exit Power Down mode by wakeup, the device will be reset.

5.2 Power Supply

CW6687B provides two on-chip low drop-out regulators (LDO) to convert from 5V to 3.3V, 1.5V to 1.2V for internal core power use. It is there to provide high power supply noise rejection and also to minimize power consumption. LDO is always enabled.

CW6687B also provides Build-in buck converter, DC-DC 5V to 1.5V

To provide a more stable and reliable power source for internal core logic, add frequency compensation through external component. [Figure 5-1](#) shows the connection.

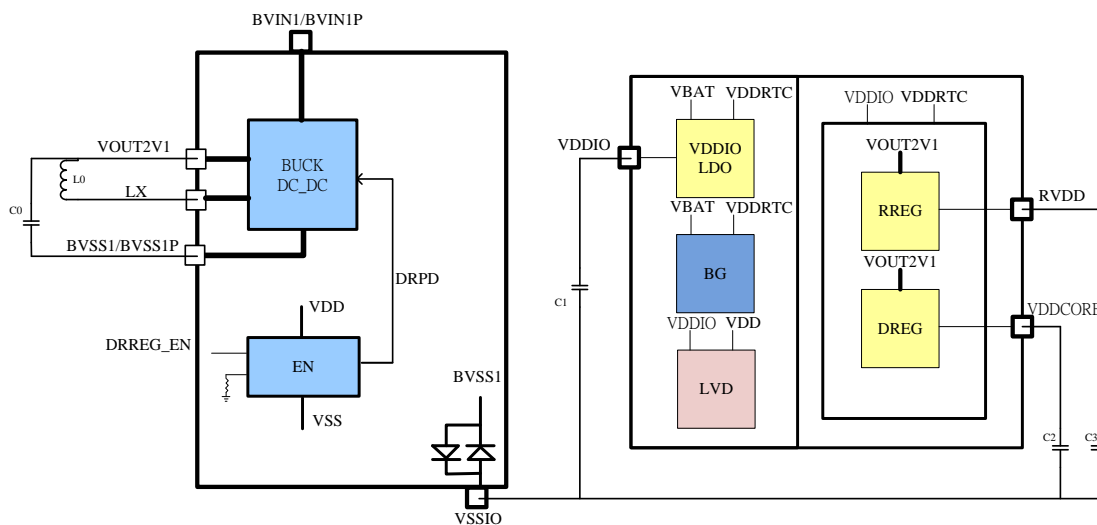

Figure 5-1 Frequency compensation through external component

Note:

- The recommended value for L0 is 10 uH.
- The recommended value for C0 is 10 uF.
- The recommended value for C1 is 10 uF.
- The recommended value for C2 is 10 uF.
- The recommended value for C3 is 10 uF.
- L0, Cx should be placed closely to the chip.

LDO enable and current select configure, please refer to “Register 5-x PWRCONx – Power control”

Register 5-1 PWRCON1 – Power control 1

Position	7	6	5	4	3	2	1	0
Name	DB1MODE1	DB1MODE0	DB1TB2	DB1TB1	DB1TB0	DZISEL2	DZISEL1	DZISEL0
Default	0	1	0	0	0	0	0	0
Access	R/W	R/W	R/W	R/W	R/W	R/W	R/W	R/W

DB1MODE1~0: BUCK mode choose

00 = force PFM mode

01 = force PWM mode

10 = ---

11 = ---

DB1TB2~0: BUCK output voltage fine tune

DZISEL2~0: ZERO_de current adjust

Register 5-2 PWRCON2 – Power control 2

Position	7	6	5	4	3	2	1	0
Name	BORS3	BORS2	BORS1	BORS0	-	DPR_AD1	DPR_AD0	DRINGOFF
Default	0	0	0	0	-	0	0	0
Access	RW	RW	RW	RW	-	RW	RW	RW

DRINGOFF:

DPR_AD1~DPR_AD0: PWM regulator voltage select:

00 = 1.2V

01 = 1.6V

10 = 1.8V

11 = 2.1V

BORS3~BORS0: VDDLDO detection voltage selection (VLVDR/VLVD S V) .

S=0000 : 2.26/2.41

S=0001 : 2.39/2.54

S=0010 : 2.54/2.68

S=0011 : 2.66/2.81

S=0100 : 2.79/2.96

S=0101 : 2.92/3.11

S=0110 : 3.06/3.24

S=0111 : 3.19/3.39
 S=1000 : 3.32/3.53
 S=1001 : 3.345/3.68
 S=1010 : 3.59/3.81
 S=1011 : 3.72/3.96
 S=1100 : 3.85/4.1
 S=1101 : 4.0/4.25
 S=1110 : 4.14/4.38
 S=1111 : 4.21/4.47

Register 5-3 PWRCON3 – Power control 3

Position	7	6	5	4	3	2	1	0
Name	V33SEL1	V33SEL0	LVD_OEB	LVD_EN			BGOPEN	BATDET
Default	1	0	0	1			0	0
Access	RW	RW	RW	RW			RW	RW

BATDET: Battery voltage detection enable

1=enable

0=disable

BGOPEN: Bg voltage output enable

1=enable

0=disable

LVD_EN: LVD module enable

1=enable

0=disable

LVD_OEB: LVD output enable

1=enable

0=disable

V33SEL1~ V33SEL0: VDDIO voltage selection

00 = 2.8V

01 = 2.9V

10 = 3.0V

11 = 3.3V

Register 5-4 PWRCON4 – Power control 4

Position	7	6	5	4	3	2	1	0
Name	CURRENTSEL_D1	CURRENTSEL_D0	V18SELR1	V18SELR0	CURRENTSEL_R1	CURRENTSEL_R0	VD2_ENB	VD1_ENB
Default	1	0	1	0	1	0	1	0
Access	RW	RW	RW	RW	RW	RW	RW	RW

VD1_ENB: VDDLDO voltage detection enable

0=enable

1=disable

VD2_ENB: External pin voltage detection enable.

0=enable

1=disable

CURRENTSEL_R1~CURRENTSEL_R0: Modulate 3.3v LDO sleep current

V18SELR1~ V18SELR0: RF part LDO output voltage selection:

00 = 1.15

01 = 1.23

10 = 1.28 default

11 = 1.32

CURRENTSEL_D1~CURRENTSEL_D0: VDD core LDO amp bias current selection

00 = X1

01 = X2

10 = X3 default

11 = X4

Register 5-5 PWRCON5 – Power control 5

Position	7	6	5	4	3	2	1	0
Name		SBG_TRM			VSEL1_LV	VSEL0_LV	V18SELD1	V18SELD0
Default								
Access	RW	RW	RW	RW	RW	RW	RW	RW

SBG_TRM: BG voltage adjust

VSEL1_LV~ VSEL0_LV: VDDCORE Output voltage of sniff mode select

00 = 1.2V

01 = 0.8V

10 = 0.9V

11 = 1.0V

V18SELD1~ V18SELD0: VDD core part LDO output voltage selection

00 = 1.15

01 = 1.23

10 = 1.28 default

11 = 1.32

Register 5-6 CHAGCON0 – charger control 0

Position	7	6	5	4	3	2	1	0
Name	CH_TERM	CH_TERM_EN	ITERM_SEL		BG_TR			
Default	0	0	0	1	0	1	1	1
Access	RW	RW	RW	RW	RW	RW	RW	RW

CH_TERM: Software stop charge enable

0 = disable

1 = enable

CH_TERM_EN: Software stop charge enable

0 = charge hardware stop

1 = software control stop charge

ITERM_SEL: Stop charge current selection

00 =20mA;

01 =40mA;

10 =60mA;

11-80mA

BG_TR: BG trimming bit, every step is 0.8%

0000 = Min

1111 = Max

Register 5-7 CHAGCON1 – charger control 1

Position	7	6	5	4	3	2	1	0
Name		DCIN_DET	CHAG_VPND	CHAG_IPND	EN_BG_BUF	CUR_TR		
Default		0	0	0	0	0	0	0
Access	RW	RW	RW	RW	RW	RW	RW	RW

DCIN_DET: DC insert detect

0 = No dc insert

1 = DC insert

CHAG_VPND: Charger voltages reach 4.1V pending

0 = Charging

1 = Finish

CHAG_IPND: Charger current reach the current that configuration

0 = Charging

1 = Finish

6 General Purpose Input/Output (GPIO)

6.1 Overview

The general-purpose input/output port (GPIO) provides 30 dedicated general purpose one-bit contacts that can be individually configured as either inputs or outputs. Contacts configured as outputs reflect internal register values, and those configured as inputs can be detected by reading internal registers. All GPIOs are divided into 5 groups: Port0, Port1, Port2, Port3 and Port4.

6.2 Features

The GPIO includes the following features:

- Drive specific data to output using the data register;
- Control the direction of the signal using the GPIO direction register;
- Enable CPU to sample the status of the corresponding inputs by reading the data register;
- Enable internal pull-up resistor using pull-up resistor control register;
- Select suitable pull-up resistor value;
- Enable internal pull-up resistor using pull-down resistor control register;
- Select suitable pull-down resistor value;
- Select suitable output driving current capability;

There are 5 types of GPIO that can meet the variation of application requirements. [Table 6-1](#) shows the difference between pad types

Table 6-1 Pad types

Type	Driving (mA)		Pull-up resistor (Kohm)			Pull-down resistor (Kohm)			Mode
A	8	24	10	/	/	10	/	/	Normal
B	8	24	10	0.2	/	10	0.2	/	Normal
C	8	24	10	200	0.5	10	3.3	0.5	Normal
D	8	24	10	/	/	10	/	/	MUTE
E	/	/	/	/	/	/	/	/	Analog

6.3 Function multiplexing

In order to provide more flexible port functions and to minimize pin counts, some of the ports are multiplexed with other peripherals or functions. [Table 6-2](#) illustrates the “Ports multiplexed mapping”.

Several GPIO are multiplexed with analog module. GPIO digital input and output must be disabled when the corresponding analog module is enabled.

Table 6-2 Ports multiplexed mapping

Pins	Func1	Func 2	Func3	Func4	Func5	Func6	Func7	Fun8	Type

Pins	Func1	Func 2	Func3	Func4	Func5	Func6	Func7	Fun8	Type
P00	AUXL0	UARTRX1		SDDAT1		SPI0DIN2			A
P01	AUXR0	UARTTX1	PORTINT/WKUP0	SDDAT2					A
P02	AUXL1					SPI0DOUT1	TMR1PWM		A
P03	AUXR1					SPI0CLK1	TMR0CAP		A
P04						SPI1DOUT/DIN1			A
P05						SPI1CLK			A
P06			PORTINT/WKUP1			SPI1DIN/SPI0DIN1	TMR0CKI/TMR1CKI	IISDI0	A
P07			PORTINT/WKUP3	Ir_input			TRM1CAP		A
P10					EMIWR				C
P11									C
P12									C
P13	ADC5							IISBCLK0	B
P14	ADC2			SDDAT3		SPI0DOUT2	TMR3CAP/TMR3PWM	IISDO0	A
P15							TMR3CKI		B
P16		BTUART1TX	UARTTX0	Ir_input			TMR2CAP/TMR2PWM	IISREF	A
P17		BTUART1RX					TMR2CKI	IISWS0	B
P20	AUXL2			SDCMD	EMIDAT0				C
P21	AUXR2/ADC1			SDCLK	EMIDAT1				C
P22	ADC3/LVDIN				EMIDAT2			IISDO1	C
P23					EMIDAT3			IISDI1	C
P24					EMIDAT4				C
P25					EMIDAT5	SPI0DIN0/DOUT0		IISBCLK1	C
P26	ADC6				EMIDAT6	SPI0CLK0		IISWS1	C
P27				SDDAT0	EMIDAT7	SPI0DOUT0			C
P30	ADC4			SDCLK		SPI0CLK3			C
P31				SDCMD		SPI0DIN3			C
P32				SDDAT0		SPI0DOUT3/DIN3			C
P33	ADC0			Ir_input	32K/xosc12m	SysClk	TRM1CAP		A
P34		UARTRX0	PORTINT/WKUP2			SPI0CLK2	TMR0PWM		C
P35	MUTE								D
P36									A
P37	GPIO								B
P40				Ir_input		SPI0CLK4			A
P41									A
P42						SPI1DIN1'			A
P43									A
P44	DACL								E
P45	DACR								E

6.4 GPIO Special Function Registers

Register 6-1 P0DIR-P0 direction Register

Position	7	6	5	4	3	2	1	0
Name	P0DIR							
Default	1	1	1	1	1	1	1	1
Access	R/W	R/W	R/W	R/W	R/W	R/W	R/W	R/W

P0xDIR: P0x direction control

0 = Output

1 = Input

Register 6-2 P1DIR-P1 direction Register

Position	7	6	5	4	3	2	1	0
Name	P1DIR							
Default	1	1	1	1	1	1	1	1
Access	R/W	R/W	R/W	R/W	R/W	R/W	R/W	R/W

P1xDIR: P1x direction control

0 = Output

1 = Input

Register 6-3 P2DIR-P2 direction Register

Position	7	6	5	4	3	2	1	0
Name	P2DIR							
Default	1	1	1	1	1	1	1	1
Access	R/W	R/W	R/W	R/W	R/W	R/W	R/W	R/W

P2xDIR: P2x direction control

0 = Output

1 = Input

Register 6-4 P3DIR-P3 direction Register

Position	7	6	5	4	3	2	1	0
Name	P3DIR							
Default	1	1	1	1	1	1	1	1
Access	R/W	R/W	R/W	R/W	R/W	R/W	R/W	R/W

P3xDIR: P3x direction control

0 = Output

1 = Input

Register 6-5 P4DIR-P4 direction Register

Position	7	6	5	4	3	2	1	0
Name	P4DIR							

Default	-	-	1	1	1	1	1	1
Access	-	-	R/W	R/W	R/W	R/W	R/W	R/W

P4xDIR: P4x direction control

0 = Output

1 = Input

Register 6-6 P0 – P0 data register

Position	7	6	5	4	3	2	1	0
Name	P0							
Default	x	x	x	x	x	x	x	x
Access	R/W	R/W	R/W	R/W	R/W	R/W	R/W	R/W

P0[x]: P0x data. Valid when P0x is used as GPIO

0 = P0x is in low state when read and output low at P0x when write

1 = P0x is in high state when read and output high at P0x when write

Register 6-7 P1 – P1 data register

Position	7	6	5	4	3	2	1	0
Name	P1							
Default	x	x	x	x	x	x	x	x
Access	R/W	R/W	R/W	R/W	R/W	R/W	R/W	R/W

P1[x]: P1x data. Valid when P1x is used as GPIO

0 = P1x is in low state when read and output low at P1x when write

1 = P1x is in high state when read and output high at P1x when write

Register 6-8 P2 – P2 data register

Position	7	6	5	4	3	2	1	0
Name	P2							
Default	x	x	x	x	x	x	x	x
Access	W/R	W/R	W/R	W/R	W/R	W/R	W/R	W/R

P2[x]: P2x data. Valid when P2x is used as GPIO

0 = P2x is in low state when read and output low at P2x when write

1 = P2x is in high state when read and output high at P2x when write

Register 6-9 P3 – P3 data register

Position	7	6	5	4	3	2	1	0
Name	P3							
Default	x	x	x	x	x	x	x	x
Access	W/R	W/R	W/R	W/R	W/R	W/R	W/R	W/R

P3[x]: P3x data. Valid when P3x is used as GPIO

0 = P3x is in low state when read and output low at P3x when write

1 = P3x is in high state when read and output high at P3x when write

Register 6-10 P4 – P4 data register

Position	7	6	5	4	3	2	1	0
Name	P4							
Default	-	-	x	x	x	x	x	x
Access	-	-	RO	RO	W/R	W/R	W/R	W/R

P3[x]: P3x data. Valid when P3x is used as GPIO

0 = P3x is in low state when read and output low at P3x when write

1 = P3x is in high state when read and output high at P3x when write

Table 6-3 DRVx register setting

Register	Address	Set bit “x” of PxDRV0 as “1”	Clear bit “x” of PxDRV0 as “0”	Initial value
P0DRV0	R/W	Driving is 24mA	Driving is 8mA	00h
P1DRV0	R/W	Driving is 24mA	Driving is 8mA	00h
P2DRV0	R/W	Driving is 24mA	Driving is 8mA	00h
P3DRV0	R/W	Driving is 24mA	Driving is 8mA	00h
P4DRV0	R/W	Driving	Driving is 8mA	00h

Table 6-4 PUPx register setting

Register	Address	Set bit “x” of PxPU0 as “1”	Clear bit “x” of PxPU0 as “0”	Initial value
P0PU0	R/W	Enable pull-up	Disable pull-up	00h
P1PU0	R/W	Enable pull-up	Disable pull-up	00h
P2PU0	R/W	Enable pull-up	Disable pull-up	00h
P3PU0	R/W	Enable pull-up	Disable pull-up	00h
P4PU0	R/W	Enable pull-up	Disable pull-up	00h

Table 6-5 PDNx register setting

Register	Address	Set bit “x” of PxPD0 as “1”	Clear bit “x” of PxPD0 as “0”	Initial value
P0PD0	R/W	Enable pull-down	Disable pull-down	00h
P1PD0	R/W	Enable pull-down	Disable pull-down	00h
P2PD0	R/W	Enable pull-down	Disable pull-down	00h
P3PD0	R/W	Enable pull-down	Disable pull-down	00h
P4PD0	R/W	Enable pull-down	Disable pull-down	00h

Register 6–11 P1PUS0– P1 pull up select

Position	7	6	5	4	3	2	1	0
Name	P17PUS0	P16PUS0	P15PUS0	P14PUS0	P13PUS0	P12PUS0	P11PUS0	P10PUS0
Default	0	0	0	0	0	0	0	0
Access	W/R	W/R	W/R	W/R	W/R	W/R	W/R	W/R

Register 6–12 P1PUS1– P1 pull up select

Position	7	6	5	4	3	2	1	0
----------	---	---	---	---	---	---	---	---

Name	P17PUS1	P16PUS1	P15PUS1	P14PUS1	P13PUS1	P12PUS1	P11PUS1	P10PUS1
Default	0	0	0	0	0	0	0	0
Access	W/R	W/R	W/R	W/R	W/R	W/R	W/R	W/R

P17PUS1, P17PUS0:

00 = select 10K pull up

01 = select 200Ω pull up

1x = reverse

P16PUS1, P16PUS0:

00 = select 10K pull up

01 = select 500Ω pull up

1x = select 200K pull up

P15PUS1, P15PUS0:

00 = select 10K pull up

01 = select 200Ω pull up

1x = reverse

P14PUS1, P14PUS0:

00 = select 10K pull up

01 = reverse

1x = reverse

P13PUS1, P13PUS0:

00 = select 10K pull up

01 = reverse

1x = reverse

P12PUS1, P12PUS0:

00 = select 10K pull up

01 = select 500Ω pull up

1x = select 200K pull up

P11PUS1, P11PUS0:

00 = select 10K pull up

01 = select 500Ω pull up

1x = select 200K pull up

P10PUS1, P10PUS0:

00 = select 10K pull up

01 = select 500Ω pull up

1x = select 200K pull up

Register 6–13 P2PUS0– P2 pull up select

Position	7	6	5	4	3	2	1	0
Name	P27PUS0	P26PUS0	P25PUS0	P24PUS0	P23PUS0	P22PUS0	P21PUS0	P20PUS0
Default	0	0	0	0	0	0	0	0
Access	W/R	W/R	W/R	W/R	W/R	W/R	W/R	W/R

Register 6–14 P2PUS1– P2 pull up select

Position	7	6	5	4	3	2	1	0
Name	P27PUS1	P26PUS1	P25PUS1	P24PUS1	P23PUS1	P22PUS1	P21PUS1	P20PUS1
Default	0	0	0	0	0	0	0	0
Access	W/R	W/R	W/R	W/R	W/R	W/R	W/R	W/R

P27PUS1, P27PUS0:

00 = select 10K pull up

01 = select 500Ω pull up

1x = select 200K pull up

P26PUS1, P26PUS0:

00 = select 10K pull up

01 = select 500Ω pull up

1x = select 200K pull up

P25PUS1, P25PUS0:

00 = select 10K pull up

01 = select 500Ω pull up

1x = select 200K pull up

P24PUS1, P24PUS0:

00 = select 10K pull up

01 = select 500Ω pull up

1x = select 200K pull up

P23PUS1, P23PUS0:

00 = select 10K pull up

01 = select 500Ω pull up

1x = select 200K pull up

P22PUS1, P22PUS0:

00 = select 10K pull up

01 = select 500Ω pull up

1x = select 200K pull up

P21PUS1, P21PUS0:

00 = select 10K pull up

01 = select 500Ω pull up

1x = select 200K pull up

P20PUS1, P20PUS0:

00 = select 10K pull up

01 = select 500Ω pull up

1x = select 200K pull up

Register 6–15 P3PUS0– P3 pull up select

Position	7	6	5	4	3	2	1	0
Name	P37PUS0	P36PUS0	P35PUS0	P34PUS0	P33PUS0	P32PUS0	P31PUS0	P30PUS0
Default	0	0	0	0	0	0	0	0
Access	W/R	W/R	W/R	W/R	W/R	W/R	W/R	W/R

Register 6–16 P3PUS1– P3 pull up select

Position	7	6	5	4	3	2	1	0
Name	P37PUS1	P36PUS1	P35PUS1	P34PUS1	P33PUS1	P32PUS1	P31PUS1	P30PUS1
Default	0	0	0	0	0	0	0	0
Access	W/R	W/R	W/R	W/R	W/R	W/R	W/R	W/R

P37PUS1, P37PUS0:

00 = select 10K pull up

01 = select 200Ω pull up

1x = reverse

P36PUS1, P36PUS0:

00 = select 10K pull up

01 = reverse

1x = reverse

P35PUS1, P35PUS0:

00 = select 10K pull up

01 = reverse

1x = reverse

P34PUS1, P34PUS0:

00 = select 10K pull up

01 = select 500Ω pull up

1x = select 200K pull up

P33PUS1, P33PUS0:

00 = select 10K pull up

01 = reverse

1x = reverse

P32PUS1, P32PUS0:

00 = select 10K pull up

01 = select 500Ω pull up

1x = select 200K pull up

P31PUS1, P31PUS0:

00 = select 10K pull up

01 = select 500Ω pull up

1x = select 200K pull up

P30PUS1, P30PUS0:

00 = select 10K pull up

01 = select 500Ω pull up

1x = select 200K pull up

Register 6–17 P1PDS0– P1 pull down select

Position	7	6	5	4	3	2	1	0
Name	P17PDS0	P16PDS0	P15PDS0	P14PDS0	P13PDS0	P12PDS0	P11PDS0	P10PDS0
Default	0	0	0	0	0	0	0	0
Access	W/R	W/R	W/R	W/R	W/R	W/R	W/R	W/R

Register 6–18 P1PDS1– P1 pull down select

Position	7	6	5	4	3	2	1	0
Name	P17PDS1	P16PDS1	P15PDS1	P14PDS1	P13PDS1	P12PDS1	P11PDS1	P10PDS1
Default	0	0	0	0	0	0	0	0
Access	W/R	W/R	W/R	W/R	W/R	W/R	W/R	W/R

P17PDS1, P17PDS0:

00 = select 10K pull down

01 = select 200Ω pull down

1x = reverse

P16PDS1, P16PDS0:

00 = select 10K pull down

01 = select 500Ω pull down

1x = select 330Ω pull down

P15PDS1, P15PDS0:

00 = select 10K pull down

01 = select 200Ω pull down

1x = reverse

P14PDS1, P14PDS0:

00 = select 10K pull down

01 = reverse

1x = reverse

P13PDS1, P13PDS0:

00 = select 10K pull down

01 = reverse

1x = reverse

P12PDS1, P12PDS0:

00 = select 10K pull down

01 = select 500Ω pull down

1x = select 330Ω pull down

P11PDS1, P11PDS0:

00 = select 10K pull down

01 = select 500Ω pull down

1x = select 330Ω pull down

P10PDS1, P10PDS0:

00 = select 10K pull down

01 = select 500Ω pull down

1x = select 330Ω pull down

Register 6–19 P2PDS0– P2 pull down select

Position	7	6	5	4	3	2	1	0
Name	P27PDS0	P26PDS0	P25PDS0	P24PDS0	P23PDS0	P22PDS0	P21PDS0	P20PDS0
Default	0	0	0	0	0	0	0	0
Access	W/R	W/R	W/R	W/R	W/R	W/R	W/R	W/R

Register 6–20 P2PDS1– P2 pull down select

Position	7	6	5	4	3	2	1	0
Name	P27PDS1	P26PDS1	P25PDS1	P24PDS1	P23PDS1	P22PDS1	P21PDS1	P20PDS1
Default	0	0	0	0	0	0	0	0
Access	W/R	W/R	W/R	W/R	W/R	W/R	W/R	W/R

P27PDS1, P27PDS0:

00 = select 10K pull down

01 = select 500Ω pull down

1x = select 330Ω pull down

P26PDS1, P26PDS0:

00 = select 10K pull down

01 = select 500Ω pull down

1x = select 330Ω pull down

P25PDS1, P25PDS0:

00 = select 10K pull down

01 = select 500Ω pull down

1x = select 330Ω pull down

P24PDS1, P24PDS0:

00 = select 10K pull down

01 = select 500Ω pull down

1x = select 330Ω pull down

P23PDS1, P23PDS0:

00 = select 10K pull down

01 = select 500Ω pull down

1x = select 330Ω pull down

P22PDS1, P22PDS0:

00 = select 10K pull down

01 = select 500Ω pull down

1x = select 330Ω pull down

P21PDS1, P21PDS0:

00 = select 10K pull down

01 = select 500Ω pull down

1x = select 330Ω pull down

P20PDS1, P20PDS0:

00 = select 10K pull down

01 = select 500Ω pull down

1x = select 330Ω pull down

Register 6–21 P3PDS0– P3 pull down select

Position	7	6	5	4	3	2	1	0
Name	P37PDS0	P36PDS0	P35PDS0	P34PDS0	P33PDS0	P32PDS0	P31PDS0	P30PDS0
Default	0	0	0	0	0	0	0	0
Access	W/R	W/R	W/R	W/R	W/R	W/R	W/R	W/R

Register 6–22 P3PDS1– P3 pull down select

Position	7	6	5	4	3	2	1	0
Name	P37PDS1	P36PDS1	P35PDS1	P34PDS1	P33PDS1	P32PDS1	P31PDS1	P30PDS1

Default	0	0	0	0	0	0	0	0
Access	W/R	W/R	W/R	W/R	W/R	W/R	W/R	W/R

P37PDS1, P37PDS0:

00 = select 10K pull down

01 = select 200Ω pull down

1x = reverse

P36PDS1, P36PDS0:

00 = select 10K pull down

01 = reverse

1x = reverse

P35PDS1, P35PDS0:

00 = select 10K pull down

01 = reverse

1x = reverse

P34PDS1, P34PDS0:

00 = select 10K pull down

01 = select 500Ω pull down

1x = select 330Ω pull down

P33PDS1, P33PDS0:

00 = select 10K pull down

01 = reverse

1x = reverse

P32PDS1, P32PDS0:

00 = select 10K pull down

01 = select 500Ω pull down

1x = select 330Ω pull down

P31PDS1, P31PDS0:

00 = select 10K pull down

01 = select 500Ω pull down

1x = select 330Ω pull down

P30PDS1, P30PDS0:

00 = select 10K pull down

01 = select 500Ω pull down

1x = select 330Ω pull down

Register 6-23 PIE0 – Port digital input enable control

Position	7	6	5	4	3	2	1	0
Name	PIE07	PIE06	PIE05	PIE04	PIE03	PIE02	PIE01	PIE00
Default	1	1	1	1	1	1	1	1
Access	R/W	R/W	R/W	R/W	R/W	R/W	R/W	R/W

PIE07: P17 digital input enables bit (For FM input)

0 = P17 Input Disabled

1 = P17 Input Enabled

PIE06: P16 digital input enables bit (For AM input)

0 = P16 Input Disabled

1 = P16 Input Enabled

PIE05: P14 digital input enables bit (For ADC2 input)

0 = P14 Input Disabled

1 = P14 Input Enabled

PIE04: P13 digital input enables bit (For ADC5 input)

0 = P13 Input Disabled

1 = P13 Input Enabled

PIE03: P03 Digital Input Enable Bit (For AUXR1)

0 = P03 Input Disabled

1 = P03 Input Enabled

PIE02: P02 Digital Input Enable Bit (For AUXL1)

0 = P02 Input Disabled

1 = P02 Input Enabled

PIE01: P01 Digital Input Enable Bit (For AUXR0)

0 = P01 Input Disabled

1 = P01 Input Enabled

PIE00: P00 Digital Input Enable Bit (For AUXL0)

0 = P00 Input Disabled

1 = P00 Input Enabled

Register 6-24 PIE1 – Port digital input enable control1

Position	7	6	5	4	3	2	1	0
Name	PIE17	PIE16	PIE15	PIE14	PIE13	PIE12	PIE11	PIE10
Default	1	0	1	1	1	1	1	1
Access	RO	R/W	R/W	R/W	R/W	R/W	R/W	R/W

PIE17: P37 Digital Input Enable Bit (For VCMBUF)

0 = P37 digital Input Disabled

1 = P37 digital Input Enabled

PIE16: P35 Digital Input Enable Bit (For UDSW)

0 = P35 digital Input Disabled

1 = P35 digital Input Enabled

PIE15: P33 Digital Input Enable Bit (For ADC0/LVDDDET)

0 = P33 digital Input Disabled

1 = P33 digital Input Enabled

PIE14: P30 Digital Input Enable Bit (For ADC4)

0 = P30 digital Input Disabled

1 = P30 digital Input Enabled

PIE13: P23 Digital Input Enable Bit

0 = P23 digital Input Enabled

1 = P23 digital Input Disabled

PIE12: P22 Digital Input Enable Bit (For ADC3 input)

0 = P22 digital Input Disabled

1 = P22 digital Input Enabled

PIE11: P21 Digital Input Enable Bit (For AUXR2 or ADC1 input)

0 = P21 digital Input Disabled

1 = P21 digital Input Enabled

PIE10: P20 Digital Input Enable Bit (For AUXL2)

0 = P20 digital Input Disabled

1 = P20 digital Input Enabled

Register 6-25 PIE2– Port digital input enable control2

Position	7	6	5	4	3	2	1	0
Name						PIE22	PIE21	PIE20
Default	0	1	1	1	1	1	1	1
Access	RO	R/W	R/W	R/W	R/W	R/W	R/W	R/W

PIE22: P26 Digital Input Enable Bit (For ADC6)

0 = P26 digital Input Enabled

1 = P26 digital Input Disabled

PIE21: P11 Digital Input Enable Bit

0 = P11 digital Input Enabled

1 = P11 digital Input Disabled

PIE20: P10 Digital Input Enable Bit

0 = P10 digital Input Enabled

1 = P10 digital Input Disabled

Register 6-26 PMUXCON0 – Port Function MUX control 0

Position	7	6	5	4	3	2	1	0
Name	Reserved	UART1_MAP	SPI0_P4_MAP	SPI0_DO_P25	WKPIN_SEL		SDTWO	P2SDEN
Default	0	0	0	0	0	0	0	0
Access	R/W	R/W	R/W	R/W	R/W	R/W	R/W	R/W

UART1_MAP: UART1 port mapping

0 = Select P16, P17

1 = Select Chip Bluetooth

SPI0_P4_MAP: SPI0 port4 mapping

0 = SPI0 clock pin map to P30

1 = SPI0 clock pin map to P40

SPI0_DO_P25: SPI0 DOUT output at P25

0 = Disable

1 = Enable

WKPIN_SEL: Port interrupt/wakeup event 2 sources selection

00 = Select P34

01 = Select DP

10 = Select DM

11 = Select IRTWKO

SDTWO: Dual SD card mode control

0 = only support one SD card plugged in at the same time

1 = support two SD cards plugged in at the same time. P30 is SDCLK shared by these two SD cards.

P2SDEN: SDCCLK, SDCCMD and SDCDAT0 port mapping control

0 = SDCCLK, SDCCMD and SDCDAT0 are mapped to P30, P31 and P32.

1 = SDCCLK, SDCCMD and SDCDAT0 are mapped to P20, P21 and P27

Register 6-27 PMUXCON1 – Port Function MUX control 1

Position	7	6	5	4	3	2	1	0
Name	P07WK_EN	Reserved	WBEDGES	WKPIN0SEL1	Reserved	Reserved	WKPIN1SEL	WKPIN0SEL
Default	1	0	0	0	0	0	0	0
Access	R/W	R/W	R/W	R/W	R/W	R/W	R/W	R/W

P07WK_EN: P07 wakeup pin3 enable bit

0 = disable

1 = enable

WBEDGES: wire less board wake pin edge selection

0 = falling edge

1 = rising edge

WKPIN0SEL1: wakeup pin0 select bit1

0 = control by WKPIN0SEL

1 = P30

WKPIN1SEL: wakeup pin1 select bit1

0 = P06

1 = BT_CTS

WKPIN0SEL: wakeup pin0 select bit0

0 = P01

1 = BT_CDCLK

Register 6-28 PMUXCON2 – Port Function MUX control 2

Position	7	6	5	4	3	2	1	0
Name	PMUXCON2							
Default	0	0	0	0	0	0	0	0
Access	R/W	R/W	R/W	R/W	R/W	R/W	R/W	R/W

PMUXCON2: PORT 2 Wake up enable

0 = disable

1 = enable

Register 6-29 PMUXCON3 – Port Function MUX control 3

Position	7	6	5	4	3	2	1	0
Name	PMUXCON3							
Default	0	0	0	0	0	0	0	0
Access	R/W	R/W	R/W	R/W	R/W	R/W	R/W	R/W

PMUXCON3: PORT 3 Wake up enable

0 = disable

1 = enable

Register 6-30 PMUXCON4 – Port Function MUX control 4

Position	7	6	5	4	3	2	1	0
Name	PMUXCON4_74				PMUXCON4_30			
Default	0	0	0	0	0	0	0	0
Access	R/W	R/W	R/W	R/W	R/W	R/W	R/W	R/W

PMUXCON4_76: P17/P16/P13P12 Wake up enable

0 = disable

1 = enable

PMUXCON4_30: P00/P01/P02/P03 Wake up enable

0 = disable

1 = enable

Register 6-31 PMUXCON5 – Port Function MUX control 5

Position	7	6	5	4	3	2	1	0
Name			WK2P_EN	DCIN_WKEN	COSEL		P30CO_EN	P33CO_EN
Default	0	0	0	0	0	0	0	0
Access	R/W	R/W	R/W	R/W	R/W	R/W	R/W	R/W

WK2P_EN: pre INT2 wakeup enable to INT2

0 = disable

1 = enable

DCIN_WKEN: internal DC IN wakeup enable to INT2

0 = disable

1 = enable

00/11 = XOSCO

COSEL: CLKO sources selection

01 = PLL 12MHz

10 = System clock

00/11 = XOSCO

P30CO_EN: P30 output clock enable bit (output clock selection by COSEL)

0 = disable

1 = enable

P33CO_EN: P33output clock enable bit (output clock selection by COSEL))

0 = disable

1 = enable

Register 6-32 PMUXCON6 – Port Function MUX control 6

Position	7	6	5	4	3	2	1	0
Name	PWM7_OEN	PWM6_OEN	PWM5_OEN	PWM4_OEN	PWM3_OEN	PWM2_OEN	PWM1_OEN	PWM0_OEN
Default	0	0	0	0	0	0	0	0
Access	R/W	R/W	R/W	R/W	R/W	R/W	R/W	R/W

PWM7_OEN: PWM7 output enable

0 = disable

1 = enable

PWM6_OEN: PWM6 output enable

0 = disable

1 = enable

PWM5_OEN: PWM5 output enable

0 = disable

1 = enable

PWM4_OEN: PWM4 output enable

0 = disable

1 = enable

PWM3_OEN: PWM3 output enable

0 = disable

1 = enable

PWM2_OEN: PWM2 output enable

0 = disable

1 = enable

PWM1_OEN: PWM1 output enable

0 = disable

1 = enable

PWM0_OEN: PWM0 output enable

0 = disable

1 = enable

6.5 Port interrupt and wakeup

CW6687B supports Port interrupt and wakeup function.

The PWKEN registers (Wakeup Enable Register) allow PIN to cause wakeup.

The PWKEN registers are set to 1Fh upon reset. Clearing bit0-4 in the PWKEN register enables wakeup on corresponding pin. The trigger condition on the selected pin can be either rising edge or falling edge. The WKED register (Wakeup Edge Select) selects the desired transition edge. Setting a bit in WKED register selects the falling edge of the corresponding pin. Resetting the bit selects the rising edge.

Once a valid transition occurs on the selected pin, the WKPND register (Wakeup Pending Register) latches the transition in the corresponding bit position. Logic '1' indicates the occurrence of the selected trigger edge on the corresponding Port pins. Upon reset, logic '0' is set to all bits of WKPND.

Note:

- For Wakeup initialization, to avoid any false signaling to port, it is recommended to perform the following procedure for Wakeup initialization:
 - Configure the edge select of Port 0 pins on WKEDG register,
 - Clear the corresponding bits on WKPND Wakeup Pending Register
 - Clear the corresponding bits in the PWKEN registers to enable the wakeup on the corresponding port pins
- Upon exiting the sleep down mode, the Multi-Input Wakeup logic causes full chip reset.

6.5.1 Wakeup registers

Register 6-33 PWKEN – Port wakeup enable

Position	7	6	5	4	3	2	1	0
Name				PWKEN4	PWKEN3	PWKEN2	PWKEN1	PWKEN0
Default	0	0	0	1	1	1	1	1
Access	R/W	R/W	R/W	R/W	R/W	R/W	R/W	R/W

PWKEN4

0 = Enable INT4 Wakeup

1 = Disable INT4 Wakeup

PWKEN3

0 = Enable INT3 Wakeup

1 = Disable INT3 Wakeup

PWKEN2

0 = Enable INT3/DP/DM/IRTWKO Wakeup

1 = Disable INT3/DP/DM/IRTWKO Wakeup

PWKEN1

0 = Enable INT1 Wakeup

1 = Disable INT1 Wakeup

PWKEN0

0 = Enable INT0 Wakeup

1 = Disable INT0 Wakeup

Note:

1. to enable WKPNDx, set PWKENx to '0'.
2. To clear WKPNDx, write '0' to WKPNDx. WKPNDx will be '0' 2 clocks later after write '0' to WKPNDx.
3. WKPNDx is cleared when PWKENx is '1'.

Register 6-34 PWKEDGE – Port wakeup Event select

Position	7	6	5	4	3	2	1	0
Name	LDOBGOE	SPI0PS1	Rev	WKEDG4	WKEDG3	WKEDG2	WKEDG1	WKEDG0
Default	0	0	0	0	x	x	x	X
Access	R/W	R/W	R/W	R/W	R/W	R/W	R/W	R/W

LDOBGOE: LDO Bandgap output enable

0 = Disable

1 = Enable

SPI0PS1: SPI0 port select 1. See chapter 16 SPI0

WKEDGx: Port interrupt Edge Select

0 = Select rising edge as interrupt trigger event

1 = Select falling edge as interrupt trigger event

Register 6-35 PWKPND – Port wakeup pending

Position	7	6	5	4	3	2	1	0
Name				WKPND4	WKPND3	WKPND2	WKPND1	WKPND0
Default	0	0	0	0	0	0	0	0
Access	R/W	R/W	R/W	R/W	R/W	R/W	R/W	R/W

WKPND4

0 = No INT4 wakeup event occurred

1 = INT4 wakeup event occurred

WKPND3

0 = No INT3 wakeup event occurred

1 = INT3 wakeup event occurred

WKPND2

0 = No INT2/DP/DM/IRTWKO wakeup event occurred

1 = INT2/DP/DM/IRTWKO wakeup event occurred

WKPND1

0 = No INT1 wakeup event occurred

1 = INT1 wakeup event occurred

WKPND0

0 = No INT0 wakeup event occurred

1 = INT0 wakeup event occurred

6.6 Operation Guide

Port 0 to Port 3 are memory-mapped into the Data Memory addressing space. They are respectively mapped into 80h, 90h, A0h and B0h registers for ports P0, P1, P2 and P3. Writing to a port data register sets the voltage levels of the corresponding port pins that have been configured to operate as outputs. Reading from a data register reads the voltage levels of the corresponding port pins.

As illustrated in Figure 8-1, there are major differences reading the port values when the port is set as input and output. When the port is set as output, the CPU will read the port value from Px register instead of the port pin value. When the port is set as input, the CPU will read the value from port pin directly instead of the port value from Px register. As a result, the user should be very careful when using Read-then-Write instructions to access the ports and change PxDIR before write the output value to Px when using port as output. For example:

Code assembler:

```
ANL P0DIR, #0FEH
MOV P0, #01h
```

Code C51:

```
P0DIR &= 0Xfe;
P0 = 0x01;
```

The first instruction in this example configures P00 as output, and then the second instruction writes the Port 0 data register (P0), which controls the output levels of the Port 0 pins, P00 through P07. Figure 8-1 shows the internal hardware structure and configuration registers for each pin of Port 0~3.

7 Timers

7.1 Timer0

Timer0 is an 8-bit timer/counter with a 7-bit prescaler. It can be configured as timer, counter or PWM generator.

Timer0 Features

- 8bits counter
- 7bits pre-scaler
- Counter mode (clock source from system clock or TMR0)
- Capture mode (event source from CAP0)
- PWM mode (PWM signal output to PWM0)

7.1.1 Timer0 Special Function Registers

Register 7-1 TMR0CON – Timer0 control

Position	7	6	5	4	3	2	1	0
Name	T0PND	T0ES	T0M		T0IS	T0PSR		
Default	0	0	0	0	0	0	0	0
Access	R/W	R/W	R/W	R/W	R/W	R/W	R/W	R/W

T0PND: Timer0 Pending Flag

0 = Not Pending

1 = Pending

T0ES: Timer0 Capture Mode Edge Select

0 = CAP0 Rising Edge

1 = CAP0 Falling Edge

T0M: Timer0 Mode

00 = Timer0 is disabled

01 = Timer0 is enabled and works in Counter Mode

10 = Timer0 is enabled and works in PWM Mode

11 = Timer0 is enabled and works in Capture Mode

T0IS: Timer0 Increase Source

0 = Select system clock cycle

1 = Select TMR0 rising edge

T0PSR: Timer0 Prescaler

000 = Timer0 counts at every counting source event

001 = Timer0 counts at every 2 counting source events

010 = Timer0 counts at every 4 counting source events

011 = Timer0 counts at every 8 counting source events

100 = Timer0 counts at every 16 counting source events

101 = Timer0 counts at every 32 counting source events

110 = Timer0 counts at every 64 counting source events

111 = Timer0 counts at every 128 counting source events

Register 7-2 TMR0CNT – Timer0 Counter

Position	7	6	5	4	3	2	1	0
Name	TMR0CNT							
Default	0	0	0	0	0	0	0	0
Access	R/W	R/W	R/W	R/W	R/W	R/W	R/W	R/W

Note: Timer0 will increase in proper condition while it is enabled. It overflows when TMR0CNT = TMR0PR, TMR0CNT will be clear to 0x00 when overflow occurs, and the interrupt flag will be set '1' by hardware.

Register 7-3 TMR0PR – Timer0 Period

Position	7	6	5	4	3	2	1	0
Name	TMR0PR							
Default	1	1	1	1	1	1	1	1
Access	WO	WO	WO	WO	WO	WO	WO	WO

Note: The overflow period of the timer is: $T_{inc-source} * T0PSR * (T0PR + 1)$.

Register 7-4 TMR0PWM – Timer0 PWM duty

Position	7	6	5	4	3	2	1	0
Name	TMR0PWM							
Default	x	x	x	x	x	x	x	x
Access	R/W	R/W	R/W	R/W	R/W	R/W	R/W	R/W

Note: TMR0PWM is reserved in timer/counter mode. In PWM mode, it is used as duty cycle setting. In capture mode, the value of TMR0CNT will be captured to TMR0PWM when selected event occurs.

7.2 Timer1

Timer1 is a 16-bit timer/counter with a 7-bit prescaler. It can be configured as timer, counter or PWM generator. Timer1 Features

- 16bits counter
- 7bits pre-scaler
- Counter mode (clock source from system clock or TMR1)
- Capture mode (event source from CAP1)
- PWM mode (PWM signal output to PWM1)

7.2.1 Timer1 Special Function Registers

Register 7-5 TMR1CON0 – Timer1 control 0

Position	7	6	5	4	3	2	1	0
Name	T1ES		T1M		T1CPSEL	T1IS		
Default	0	0	0	0	0	0	0	0
Access	R/W	R/W	R/W	R/W	R/W	R/W	R/W	R/W

T1ES: Timer1 Capture Edge Select

00 = CAP1 Rising Edge

01 = CAP1 Falling Edge

1X = CAP1 Rising Edge and Falling Edge

T1M: Timer1 Mode Select

00 = Timer1 is disabled

01 = Timer1 is enabled and works in Counter Mode

10 = Timer1 is enabled and works in PWM Mode

11 = Timer1 is enabled and works in Capture Mode

T1CPSEL: Timer1 capture input pin select

0 = Capture CAP1

1 = Capture IR1

T1IS: Timer1 Increase Source

000 = TMR1 Rising Edge

001 = TMR1 Falling Edge

010 = TMR1 Rising and Falling Edge

011 = External 32 KHz crystal oscillator

1xx = System clock cycle

Register 7-6 TMR1CON1 – Timer1 control 1

Position	7	6	5	4	3	2	1	0
Name	T1TPND	T1CPND	T1TIE	T1CIE	-	T1PSR		
Default	0	0	0	0	-	0	0	0
Access	R/W	R/W	R/W	R/W	-	R/W	R/W	R/W

T1TPND: Timer1 over Flow Pending Bit

0 = Not Pending

1 = Pending

T1CPND: Timer1 Capture mode Pending Bit

0 = Not Pending

1 = Pending

T1TIE: Timer1 over Flow Interrupt Enable Bit

0 = Interrupt Disable

1 = Interrupt Enable

T1CIE: Timer1 Capture mode Interrupt Enable Bit

0 = Disable

1 = Enable

T1PSR: Timer1 Prescaler

000 = Timer1 counts at every counting source event

001 = Timer1 counts at every 2 counting source events

010 = Timer1 counts at every 4 counting source events

011 = Timer1 counts at every 8 counting source events

100 = Timer1 counts at every 16 counting source events

101 = Timer1 counts at every 32 counting source events

110 = Timer1 counts at every 64 counting source events

111 = Timer1 counts at every 128 counting source events

Register 7-7 TMR1CNTH/TMR1CNTL – Timer1 Counter

Position	7	6	5	4	3	2	1	0
Name	TMR1CNTH/TMR1CNTL							
Default	0	0	0	0	0	0	0	0
Access	R/W	R/W	R/W	R/W	R/W	R/W	R/W	R/W

Note: Timer1 will increase in proper condition while it is enabled, it overflows when TMR1CNT = TMR1PR, TMR1CNT will be cleared to 0x0000 when overflow, and the interrupt flag will be set '1' by hardware.

Register 7-8 TMR1PRH/TMR1PRL – Timer1 Period

Position	7	6	5	4	3	2	1	0
Name	TMR1PRH/TMR1PRL							
Default	1	1	1	1	1	1	1	1
Access	WO	WO	WO	WO	WO	WO	WO	WO

The overflow period of the timer is: $T_{inc-source} * T1PSR * (T1PR + 1)$.

Register 7-9 TMR1PWMH/TMR1PWML – Timer1 PWM duty

Position	7	6	5	4	3	2	1	0
Name	TMR1PWMH/TMR1PWML							
Default	x	x	x	x	x	x	x	x
Access	R/W	R/W	R/W	R/W	R/W	R/W	R/W	R/W

Note: TMR1PWM is reserved in timer/counter mode. In PWM mode, it is used as duty cycle setting. In capture mode, the value of TMR1CNT will be captured to TMR1PWM when the selected event occurs.

7.3 Timer2

Timer2 is a 16-bit timer/counter with a 7-bit prescaler. It can be configured as timer, counter or PWM generator.

7.3.1 Timer2 Features

- 16bits counter
- 7bits pre-scaler
- Counter mode (clock source from system clock or TMR2)

- Capture mode (event source from CAP2)
- PWM mode (PWM signal output to PWM2)

7.3.2 Timer2 Special Function Registers

Register 7-10 TMR2CON0 – Timer2 control 0

Position	7	6	5	4	3	2	1	0
Name	T2ES		T2M		Reserve	T2IS		
Default	0	0	0	0	0	0	0	0
Access	R/W	R/W	R/W	R/W	R/W	R/W	R/W	R/W

T2ES: Timer2 Capture Edge Select

00 = CAP2 Rising Edge

01 = CAP2 Falling Edge

1X= CAP2 Rising Edge and Falling Edge

T2M: Timer2 Mode Select

00 = Timer2 is disabled

01 = Timer2 is enabled and works in Counter Mode

10 = Timer2 is enabled and works in PWM Mode

11 = Timer2 is enabled and works in Capture Mode

T2IS: Timer2 Increase Source

000 = TMR2 Rising Edge

001 = TMR2 Falling Edge

010 = TMR2 Rising and Falling Edge

011 = External 32 KHz crystal oscillator

1xx = System Clock cycle

Register 7-11 TMR2CON1 – Timer2 control 1

Position	7	6	5	4	3	2	1	0
Name	T2TPND	T2CPND	T2TIE	T2CIE	-	T2PSR		
Default	0	0	0	0	-	0	0	0
Access	R/W	R/W	R/W	R/W	-	R/W	R/W	R/W

T2TPND: Timer2 over Flow Pending Bit

0 = Not Pending

1 = Pending

T2CPND: Timer2 Capture mode Pending Bit

0 = Not Pending

1 = Pending

T2TIE: Timer2 over Flow Interrupt Enable Bit

0 = Interrupt Disable

1 = Interrupt Enable

T2CIE: Timer2 Capture mode Interrupt Enable Bit

0 = Disable

1 = Enable

T2PSR: Timer2 Prescaler

000 = Timer2 counts at every counting source event

001 = Timer2 counts at every 2 counting source events

010 = Timer2 counts at every 4 counting source events

011 = Timer2 counts at every 8 counting source events

100 = Timer2 counts at every 16 counting source events

101 = Timer2 counts at every 32 counting source events

110 = Timer2 counts at every 64 counting source events

111 = Timer2 counts at every 128 counting source events

Register 7-12 TMR2CNTH/TMR2CNTL – Timer2 Counter

Position	7	6	5	4	3	2	1	0
Name	TMR2CNTH/TMR2CNTL							
Default	0	0	0	0	0	0	0	0
Access	R/W	R/W	R/W	R/W	R/W	R/W	R/W	R/W

Note: Timer2 will increase in proper condition while it is enabled, it overflows when TMR2CNT = TMR2PR, TMR2CNT will be clear to 0x0000 when overflow, and the interrupt flag will be set as '1' by hardware.

Register 7-13 TMR2PRH/TMR2PRL – Timer2 Period

Position	7	6	5	4	3	2	1	0
Name	TMR2PRH/TMR2PRL							
Default	1	1	1	1	1	1	1	1
Access	WO	WO	WO	WO	WO	WO	WO	WO

The overflow period of the timer is: $Tinc-source * T2PSR * (T2PR + 1)$.

Register 7-14 TMR2PWMH/TMR2PWML – Timer2 PWM duty

Position	7	6	5	4	3	2	1	0
Name	TMR2PWMH/TMR2PWML							
Default	x	x	x	x	x	x	x	x
Access	R/W	R/W	R/W	R/W	R/W	R/W	R/W	R/W

Note: TMR2PWM is reserved in timer/counter mode. In PWM mode, it is used as duty cycle setting. In capture mode, the value of TMR2CNT will be captured to TMR2PWM when selected event occurs.

7.4 Timer3

Timer3 is an 8-bit timer/counter with a 7-bit prescaler. It can be configured as timer, counter or PWM generator.

7.4.1 Timer3 Features

- 8bits counter
- 7bits pre-scaler
- Counter mode (clock source from system clock or TMR3)
- Capture mode (event source from CAP3)
- PWM mode (PWM signal output to PWM3)

7.4.2 Timer3 Special Function Registers

Register 7-15 TMR3CON – Timer3 control

Position	7	6	5	4	3	2	1	0
Name	T3PND	T3ES	T3M		T3IS	T3PSR		
Default	0	0	0	0	0	0	0	0
Access	R/W	R/W	R/W	R/W	R/W	R/W	R/W	R/W

T3PND: Timer3 Pending Flag

0 = Not Pending

1 = Pending

T3ES: Timer3 Capture Mode Edge Select

0 = CAP3 Rising Edge

1 = CAP3 Falling Edge

T3M: Timer3 Mode

00 = Timer3 is disabled

01 = Timer3 is enabled and works in Counter Mode

10 = Timer3 is enabled and works in PWM Mode

11 = Timer3 is enabled and works in Capture Mode

T3IS: Timer3 Increase Source

0 = System Clock

1 = TMR3 rising edge

T3PSR: Timer3 Prescaler

000 = Timer3 counts at every counting source event

001 = Timer3 counts at every 2 counting source events

010 = Timer3 counts at every 4 counting source events

011 = Timer3 counts at every 8 counting source events

100 = Timer3 counts at every 16 counting source events

101 = Timer3 counts at every 32 counting source events

110 = Timer3 counts at every 64 counting source events

111 = Timer3 counts at every 128 counting source events

Register 7-16 TMR3CNT – Timer3 Counter

Position	7	6	5	4	3	2	1	0
Name	T3CNT							
Default	0	0	0	0	0	0	0	0
Access	R/W	R/W	R/W	R/W	R/W	R/W	R/W	R/W

Note: Timer3 will increase in proper condition while it is enabled. It overflows when $TMR3CNT = TMR3PR$, $TMR3CNT$ will be clear to 0x00 when overflow occurs, and the interrupt flag will be set '1' by hardware.

Register 7-17 TMR3PR – Timer3 Period

Position	7	6	5	4	3	2	1	0
Name	TMR3PR							
Default	1	1	1	1	1	1	1	1
Access	WO	WO	WO	WO	WO	WO	WO	WO

Note: The overflow period of the timer is: $Tinc-source * T3PSR * (T3PR + 1)$.

Register 7-18 TMR3PWM – Timer3 PWM duty

Position	7	6	5	4	3	2	1	0
Name	TMR3PWM							
Default	x	x	x	x	x	x	x	x
Access	R/W	R/W	R/W	R/W	R/W	R/W	R/W	R/W

Note: TMR3PWM is reserved in timer/counter mode. In PWM mode, it is used as duty cycle setting. In capture mode, the value of TMR3CNT will be captured to TMR3PWM when selected event occurs.

7.5 Watchdog Timer (WDT)

The Watchdog Timer (WDT) logic consists of a 20bit Watchdog Timer. An internal RC oscillator running at 32 KHz clocks the Watchdog Timer. When device resets, the WDT is disabled and user should enable the WDT if it is needed.

In the default configuration, WDT overflows in 2ms. The application program needs to write a '1' into WDTCON [5] at least once 2 ms to prevent WDT time out. The lower 3 bits of the WDTCON register control the selection of overflow time period.

7.5.1 Watchdog Wake up

WDT can be used to wake up CW6687B from Idle, Hold or Sleep mode. RSTEN bit (WDTCON [3]) is used to determine the actions after WDT wake up. When RSTEN is set to 0, the watchdog will generate a non-reset wake up after counter overflows. And When RSTEN is set to 1, the watchdog will wake up CW6687B by resetting the whole chip. After non-reset wake up CW6687B will continue to execute next instruction.

- During Idle mode, CW6687B can perform wakeup by WDT with interrupt or reset.
- During Hold mode, CW6687B perform wakeup by WDT with interrupt or reset or just continue to execute the next instruction.
- During Sleep mode, CW6687B perform wakeup by WDT with reset.
- During Deep Sleep mode, CW6687B cannot achieve wakeup by WDT.

7.5.2 Watchdog SFR

Register 7-19 WDTCON – Watchdog control

Position	7	6	5	4	3	2	1	0
Name	WDTPD	WDTTO	CLRWDT	WDTEN	RSTEN	WDTPS		
Default	0	0	0	1	1	1	0	1
Access	RO	RO	WO	R/W	R/W	R/W	R/W	R/W

WDTPD:

0 = read '0' before sleep operation

1 = read '1' after sleep operation

WDTTO:

0 = Read '0' after clear Watchdog or Power up

1 = Read '1' after Watchdog time out

CLRWDT:

1 = Clear WDT counter

0 = No action

WDTEN:

0 = Disables the Watchdog timer

1 = Enables the Watchdog timer

RSTEN:

0 = Disables the Watchdog reset

1 = Enables the Watchdog reset

WDTPS: WDT time out period setting

000 = 2ms

001 = 8ms

010 = 32ms

011 = 128ms

100 = 512ms

101 = 2048ms

110 = 8192ms

111 = 32768ms

7.6 Independent Power Real Time Clock Counter (IRTCC)

7.6.1 IRTCC Controller

IRTCC control can generate two interrupts: Second interrupt and Alarm interrupt.

IRTCC's second interrupt can be enabled by writing '1' to IRTIE bit. When IRTCC works and IRTIE = 1, IRTCC second interrupt will be generated every 1 second by setting IRTPND to 1. IRTPND can be cleared by software by writing 0 to IRTPND bit.

IRTCC alarm interrupt can be enabled by writing 1 to IRTALIE bit. When IRTCC works and IRTALIE = 1, IRTCC alarm interrupt will be generated when the current time is equal to the pre-set time by setting IRTALPND to 1. IRTALPND can be cleared by software by writing 0 to IRTALPND bit.

IRTCC is divided to two parts; one part is IRTCC control. The power of IRTCC control is VDDCORE. Another part is IRTCC. The part of IRTCC is VDDRTC. The communication between two parts is used like SPI protocol.

7.6.2 IRTCC Timer

IRTCC timer can be powered independently. It can work even when other logic in CW6687B is powered off.

There is 6-bit valid address for the 64-byte user RAM, so the upper 2-bit of address in the writing RTC_RAM or reading RTC_RAM command is ignored. After one byte write/read, the internal address can increase automatically; this characteristic provides a burst mode to write/read the RAM. If the internal addresses increase to a number greater than 63, it will roll back to 0.

7.6.3 Communication with IRTCC Timer

Special commands and corresponding parameters are used to communicate with IRTCC timer's internal control or status registers and SRAM.

Table 7-1 IRTCC components communication commands

IRTCC component	Component type	Operation	Command Code	Command Parameters
Write_CFG(RTCCON)	A	Write	0x55	One byte
Read_CFG(RTCCON)	A	Read	0x54	One byte
Write_CFG3(RTCC3)	A	Write	0x59	One byte
Write_RTC	B	Write	0xF0	Four byte
Read_RTC	B	Read	0xE0	Four byte
Write_ALM	B	Write	0x53	Four byte
Read_ALM	B	Read	0x52	Four byte
Write_RAM	C	Write	0x57	One byte address and N byte data
Read_RAM	C	Read	0x56	One byte address and N byte data
Write_PWR(PWRCON)	A	Read	0x5a	One byte
Write_WKO(WKOCON)	A	Write	0x5b	One byte

IRTCC component	Component type	Operation	Command Code	Command Parameters
Read_WKO(WKOCN)	A	Read	0xa1	One byte
Write_VCL(VOLTAGE)	A	Write	0xa2	One byte
Read_VCL(VOLTAGE)	A	Read	0xa3	One byte
Read_PWR(PWRCON)	A	Read	0x65	One byte
Write_STA(WKSTA)	A	Write	0x63	One byte
Read_STA(WKSTA)	A	Read	0x62	One byte

Communication operations:

1, Read or write A type components

Write:

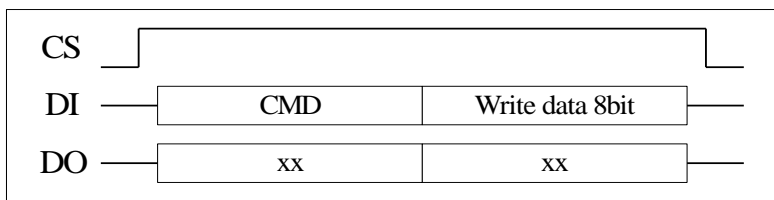

Read:

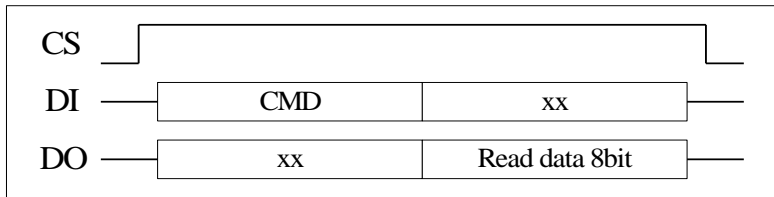

2, Read or write B type components

Write:

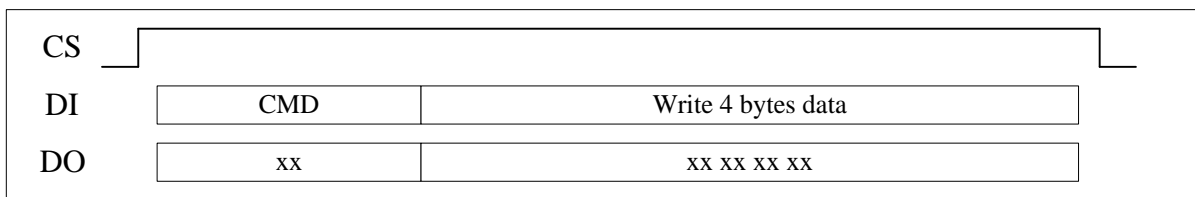

Read:

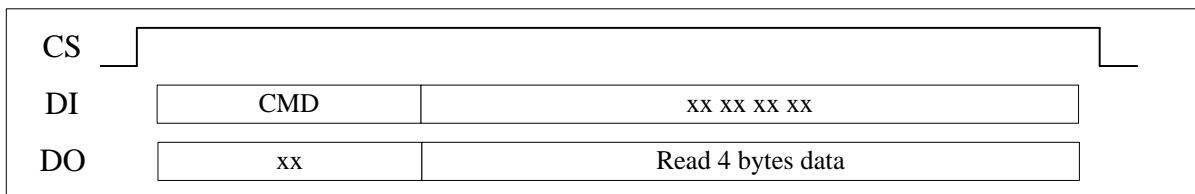

3, Read or write C type components

Write:

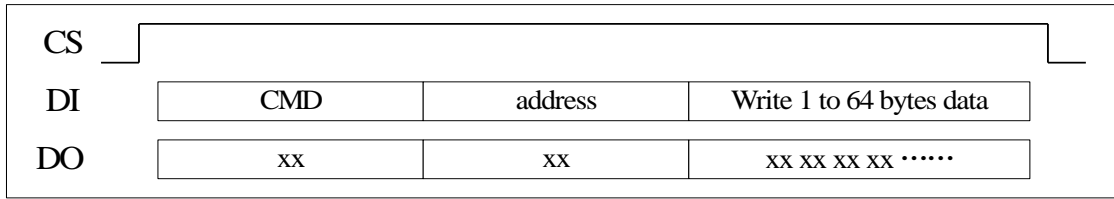

Read:

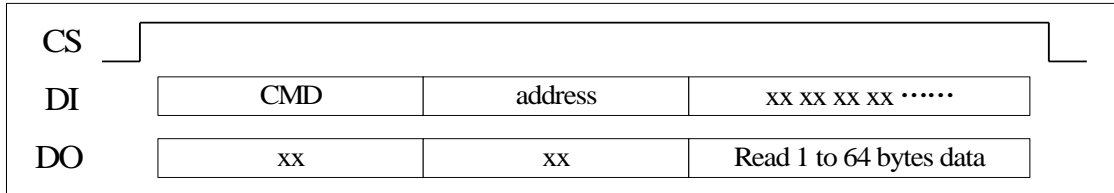

7.6.4 IRTCC Special Function Registers

Register 7-20 IRTCON – IRTCC control

Position	7	6	5	4	3	2	1	0
Name	IRTCSTEN	Reserved	IRTALPND	IRTALIE	IRTPND	IRTIE	DONE	EN
Default	0	0	0	0	0	0	0	0
Access	R/W	R/W	R/W	R/W	R/W	R/W	R/W	R/W

IRTCSTEN: IRTCC sleep wake up enable

0 = Disable

1 = Enable

IRTALPND: IRTCC alarm pending

0 = No pending (Write 0 to clear pending)

1 = Pending

IRTALIE: IRTCC alarm interrupt enable

0 = Disable

1 = Enable

IRTALIE must be '1' if IRTCC alarm is used to wake up system.

IRTPND: IRTCC second pending

0 = No pending (Write 0 to clear pending)

1 = Pending

IRTALIE: IRTCC alarm second enable

0 = Disable

1 = Enable

IRTIE must be '1' if IRTCC second is used to wake up system.

DONE: Communication done flag

0 = done

1 = not done

EN: IRTCC communications enable

0 = Disable

1 = Enable

Register 7-21 IRTCDAT – RTCC communication data

Position	7	6	5	4	3	2	1	0
Name	IRTCDAT							
Default	x	x	x	x	x	x	x	x
Access	R/W	R/W	R/W	R/W	R/W	R/W	R/W	R/W

Write to IRTCDAT will start IRTCC communication and set DONE flag to 1.

Read IRTCDAT will return IRTCC data.

Register 7-22 SECCNT –IRTCC timer conter

Position	7	6	5	4	3	2	1	0
Name	SECCNT7	SECCNT6	SECCNT5	SECCNT4	SECCNT3	SECCNT2	SECCNT1	SECCNT0
Default	x	x	x	x	x	x	x	x
Access	WO	WO	WO	WO	WO	WO	WO	WO

RTCC second counter

Register 7-23 IRTCON1 – RTCC control1

Position	7	6	5	4	3	2	1	0
Name	-	-	-	-	RTC_POR	IRTCC_POR_EN	TIMER	TIMERIE
Default	-	-	-	-		0	0	0
Access	-	-	-	-	R/O	R/W	R/W	R/W

RTC_POR: RTCC POR bit

0 = RTCC POR is 0

1 = RTCC POR is 1

NOTE: only design specification can be known.

IRTCC_POR_EN: IRTCC POR reset system clock enable

0 = Disable

1 = Enable

TIMER: Timer pending

0 = No pending (Write 0 to clear pending)

1 = When SECCNT equal to internal counter

TIMERIE: Timer pending interrupt enable

0 = Disable

1 = Enable

Register 7-24 RANDOM_CNT – random center regent

Position	7	6	5	4	3	2	1	0
Name	RANDOM_CNT[7:0]							
Default	-	-	-	-	-	-	-	-

Access	RO	RO	RO	RO	RO	RO	RO	RO
--------	----	----	----	----	----	----	----	----

RANDOM: random center of 32k without default value

7.6.5 IRTCC components description

IRTCC timer can be powered independently. It can work even when other logic in TIGER is powered off.

In IRTCC timer, there is one 8-bit configure register, one 32-bit real time counter, one 32-bit alarm register and 64-byte user RAM. All of these can be accessed (read or write) by several command sets through the IRTCC control.

There is 6-bit valid address for the 64-byte user RAM, so the upper 2-bit of address in the Write_RAM or Read_RAM command are ignored. After one byte write/read, the internal address can increase automatically, this characteristic provides a burst mode to write/read the RAM. If the internal address increase to a number greater than 63, it will roll back to 0.

Register 7-25 RTCCON - RTCC control

Position	7	6	5	4	3	2	1	0
Name	32K_EN	12M_EN	SPOR_WKEN	Reserved	F1HZEN	F32KHZEN	EX32KSEL	WKO32KOUT
Default	0	0	0	0	1	1	0	0
Access	R/W	R/W	R/W	R/W	R/W	R/W	R/W	R/W

32K_EN: xosc 32k enable

0 = Disable

1 = Enable

12M_EN: xosc 12m enable

0 = Disable

1 = Enable

SPOR_WKEN: System POR wakeup enable

0 = disable

1 = enable

F1HZEN: 1Hz signal output enable

0 = Disable

1 = Enable

F32KHZEN: 32 KHz signal output enable

0 = Disable

1 = Enable

EX32KSEL: RTCC timer clock source select

0 = RTCC timer works with XOSC 32K.

1 = RTCC timer works with IRTOSC 32KHz

WKO32KOUT: WKO output RTC analog 32K XOSC

0 = Disable

1 = Enable

Register 7-26 RTCC3 - RTCC configure register3

Position	7	6	5	4	3	2	1	0
Name	-	-	-				DRSEL	
Default	-	-	-	0	0	0	0	0
Access	-	-	-				WO	WO

DRSEL: IRTCC OSC drive select

Register 7-27 PWRCON - Power control register

Position	7	6	5	4	3	2	1	0
Name	PD_FLAG	BIAS_SEL		BUCK_MODE_SEL	RVDD_EN	DVDD_EN	VDDIO_EN	PMU_EN
Default	1	1	1	0	0	0	0	0
Access	R/W	R/W	R/W	R/W	R/W	R/W	R/W	R/W

PD_FLAG: Power down flag

BIAS_SEL [1:0]: LDO amp bias current selection

00 = X0

01 = X1

10 = X2, default

11 = X4

BUCK_MODE_SEL: PMU mode select bit

0 = LDO mode

1 = BUCK mode

RVDD_EN: RVDD enable bit

0 = enable

1 = disable

DVDD_EN: DVDD enable bit

0 = enable

1 = disable

VDDIO_EN: VDDIO enable bit

0 = enable

1 = disable

PMU_EN: PMU enable bit

0 = enable

1 = disable

Register 7-28 WKOCON - WKO control register

Position	7	6	5	4	3	2	1	0
Name	WKPIN_STA	FLTEN	ALMOE	WKOEN	WKOUTEN	WKOINEN	ALMEN	DCIN_WKEN
Default	0	0	0	0	0	0	0	0
Access	R/W	W/R	W/R	W/R	W/R	W/R	R/W	R/W

WKPIN_STA: Wake up pin output state

0 = wake up pin output 0

1 = wake up pin output 1

FITEN: WKO 1ms filter enable

0 = disable

1 = enable

ALMOE: Alarm output enable at WKO PIN output enable

0 = Disable

1 = Enable

WKOEN: WKO PIN enable

0 = Disable

1 = Enabled

WKOUTEN: WKO PIN output enable bit

0 = Disable

1 = Enabled

WKOINEN: WKO PIN input enable bit

0 = Disable

1 = Enabled

ALMEN: Alarm function enable

0 = Disable

1 = Enable

DCIN_WKEN: DCIN wake up enable bin

0 = disable

1 = enable

Register 7-29 WKSTA - Wake up status register

Position	7	6	5	4	3	2	1	0
Name	-	-	WKO_CIN	DCINPND	HVDR	LVDPND	WKOPND	ALMOT
Default	0	0	0	0	1	0	0	0
Access	R	R	R	R	R	R/W	R	R

WKO_CIN: wko pin state read

DCINPND: DC IN wake up pending

0 = No dc in wake up pending

1 = dc in wake up pending

HVDR: HVD flag

0 = VDDLDO is no higher than configuration

1 = VDDLDO is higher than configuration

LVDPND: LVD pending

0 = VDDLDO is higher than 2V

0 = VDDLDO is lower than 2V

Write this bit 0 will clear LVDPND

WKOPND: IRTWKO wake up pending

0 = No wakeup

1 = IRTWKO pin wake up pending

ALMOT: Alarm match flag.

0 = No alarm match happen

1 = Alarm match

This flag is set to '1' by hardware when alarm register match real timer counter. It can be clear to '0' of ALMEN is set to '0' or 'Write_ALM' is detected.

Register 7-30 VCL VOLTAGE configure register

Position	7	6	5	4	3	2	1	0
Name	SC_RTC[4]	SC_RTC[3]	SC_RTC[2]	SC_RTC[1]	SC_RTC[0]	HVDS	HVDEN	LV DEN
Default	1	1	0	1	0	0	0	0
Access	W/R	W/R	W/R	W/R	W/R	W/R	W/R	W/R

SC_RTC [4]: OSCO OSCI capacitance select

SC_RTC [3:2]: OSCO capacitance select

SC_RTC [1:0]: OSCI capacitance select

HVDS: HVD level select

0 = 4.0V

1 = 4.2V

LV DEN: LVD enable bit

0 = Disabled

1 = Enabled

In IRTCC timer, there is one 32-bit real time counter. The unit of this counter is per second. If display the time on LCD, you should convert to second, minute, hour, date and so on. When use "Write_RTC" command to config this counter, the first byte is config the highest counter, and the forth byte is config the lowest counter. When use "Read_RTC" command to read this counter, the first byte output is the highest counter, and the forth byte output is the lowest counter.

In IRTCC timer, there is one 32-bit alarm register. The unit of this counter is per second. If display the time on LCD, you should convert to second, minute, hour, date and so on. When use "Write_ALM" command to config this counter, the first byte is config the highest counter, and the forth byte is config the lowest counter. When use "Read_ALM" command to read this counter, the first byte output is the highest counter, and the forth byte output is the lowest counter.

7.6.6 IRTCC Operating Guide

; Write RTC Config

Write_Cfg:

ORL IRTCON, #(1<<0) ;RTC enable

```
MOV    A, #55H
CALL   Send_Dat
MOV    A, #0CCH
CALL   Send_Dat
ANL    IRTCON, #~(1<<0)    ;RTC Disable
RET

;-----
;   Read Config
Read_Cfg:
ORL    IRTCON, #(1<<0)    ;RTC enable
MOV    A, #54H
CALL   Send_Dat
MOV    A, #00H
CALL   Send_Dat
ANL    IRTCON, #~(1<<0)    ;RTC Disable
RET

;-----
;   Write_RTC
Write_RTC:
ORL    IRTCON, #(1<<0)    ;RTC enable

MOV    A, #0F0H
CALL   Send_Dat

MOV    A, #98H
CALL   Send_Dat
MOV    A, #76H
CALL   Send_Dat
MOV    A, #54H
CALL   Send_Dat
MOV    A, #32H
CALL   Send_Dat

ANL    IRTCON, #~(1<<0)    ;RTC Disable
RET

;-----
;   Read_RTC
Read_RTC:
```

```
ORL    IRTCON, #(1<<0)    ;RTC enable
```

```
MOV    A, #0E0H
```

```
CALL   Send_Dat
```

```
MOV    A, #00H
```

```
CALL   Send_Dat
```

```
MOV    A, IRTCDAT
```

```
MOV    A, #00H
```

```
CALL   Send_Dat
```

```
MOV    A, IRTCDAT
```

```
MOV    A, #00H
```

```
CALL   Send_Dat
```

```
MOV    A, IRTCDAT
```

```
MOV    A, #00H
```

```
CALL   Send_Dat
```

```
MOV    A, IRTCDAT
```

```
ANL    IRTCON, ~(1<<0)    ;RTC Disable
```

```
RET
```

```
;-----
```

```
; Write RTC Alarm
```

```
Write_Alam:
```

```
ORL    IRTCON, #(1<<0)    ;RTC enable
```

```
MOV    A, #53H
```

```
CALL   Send_Dat
```

```
MOV    A, #12H
```

```
CALL   Send_Dat
```

```
MOV    A, #34H
```

```
CALL   Send_Dat
```

```
MOV    A, #56H
```

```
CALL   Send_Dat
```

```
MOV    A, #78H
```

```
CALL   Send_Dat
```

```
ANL    IRTCON, ~(1<<0)    ;RTC Disable
```

```
RET
```

;-----

; Read RTC Alarm

Read_Alarm:

ORL IRTCON, #(1<<0) ;RTC enable

MOV A, #52H

CALL Send_Dat

MOV A, #00H

CALL Send_Dat

MOV A, RTCDAT

MOV A, #00H

CALL Send_Dat

MOV A, RTCDAT

MOV A, #00H

CALL Send_Dat

MOV A, RTCDAT

MOV A, #00H

CALL Send_Dat

MOV A, RTCDAT

ANL IRTCON, #~(1<<0) ;RTC Disable

RET

;-----

; Write RTC RAM

Write_Ram:

ORL IRTCON, #(1<<0) ;RTC enable

MOV A, #57H

CALL Send_Dat

MOV A, #00H ;Ram Address

CALL Send_Dat

MOV R0, #64

Write_Ram_Loop:

MOV A, #55H

CALL Send_Dat

DJNZ R0, Write_Ram_Loop

```

    ANL    IRTCON, #~(1<<0)    ;RTC Disable
    RET

;-----
;   Read RTC RAM
Read_Ram:
    ORL    IRTCON, #(1<<0)    ;RTC enable

    MOV    A, #56H
    CALL   Send_Dat
    MOV    A, #00H            ;Ram Address
    CALL   Send_Dat

    MOV    R0, #64
Read_Ram_Loop:
    MOV    A, #00H
    CALL   Send_Dat
    MOV    A, IRTCDAT
    DJNZ   R0, Read_Ram_Loop
    ANL    IRTCON, #~(1<<0)    ;RTC Disable
    RET

;   Write VCL
Write_Vcl:
    ORL    IRTCON, #(1<<0)    ;RTC enable
    MOV    A, #0A2H
    CALL   Send_Dat
    MOV    A, #0A7H
    CALL   Send_Dat
    ANL    IRTCON, #~(1<<0)    ;RTC Disable
    RET

;-----
;   Read VCL
Read_Vcl:
    ORL    IRTCON, #(1<<0)    ;RTC enable
    MOV    A, #0A3H
    CALL   Send_Dat
    MOV    A, #00H
    CALL   Send_Dat
    ANL    IRTCON, #~(1<<0)    ;RTC Disable
    RET

```

; Write WKO

Write_Wko:

```
    ORL    IRTCON, #(1<<0)      ;RTC enable
    MOV    A, #5BH
    CALL   Send_Dat
    MOV    A, #0A7H
    CALL   Send_Dat
    ANL    IRTCON, #~(1<<0)     ;RTC Disable
    RET
```

;-----

; Read WKO

Read_Wko:

```
    ORL    IRTCON, #(1<<0)      ;RTC enable
    MOV    A, #0A1H
    CALL   Send_Dat
    MOV    A, #25H
    CALL   Send_Dat
    ANL    IRTCON, #~(1<<0)     ;RTC Disable
    RET
```

; Write PWR

Write_Pwr:

```
    ORL    IRTCON, #(1<<0)      ;RTC enable
    MOV    A, #5AH
    CALL   Send_Dat
    MOV    A, #003H
    CALL   Send_Dat
    ANL    IRTCON, #~(1<<0)     ;RTC Disable
    RET
```

;-----

; Send Data

Send_Dat:

```
    MOV    RTCDAT, A
Send_Dat_Loop:
    MOV    A, IRTCON
    JB     ACC.1, Send_Dat_Loop
    RET
```

;-----

8 Universal Asynchronous Receiver/Transmitter (UART)

8.1 UART0

8.1.1 Overview

UART0 is a serial port capable of asynchronous transmission. The UART0 can function in full duplex mode. Receive data is buffered in a holding register. This allows the UART0 to start reception of a second incoming data byte before software has finished reading the previous data byte. *Figure 8-1* illustrates the UART0 Block Diagram.

When PSEL = 0

- Receive pin (RX) – UART0RX0
- Transmit pin (TX) – UART0TX0

When PSEL = 1

- Receive pin (RX) – UART0RX1
- Transmit pin (TX) – UART0TX1

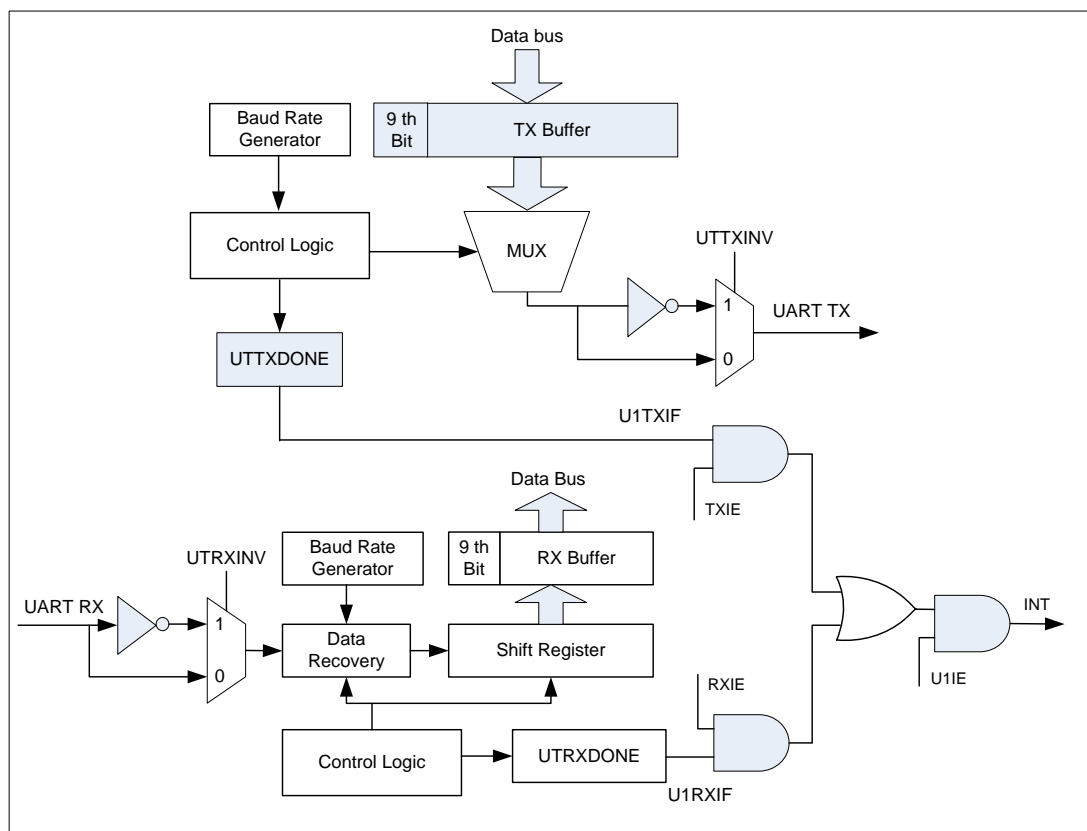

Figure 8-1 UART0 Block Diagram

8.1.2 UART0 Special Function Registers

Register 8-1 UARTCON – UART0 control

Position	7	6	5	4	3	2	1	0
Name	UTSBS	UTTXNB	NBITEN	UTEN	UTTXINV	UTRXINV	TXIE	RXIE
Default	0	1	0	0	0	0	0	0
Access	R/W	R/W	R/W	R/W	R/W	R/W	R/W	R/W

UTSBS: Stop Bit Select

0 = 1 bit as Stop Bit

1 = 2 bits as Stop Bit

UTTXNB: The ninth bit data of transmitter buffer. Write the ninth bit into this location that you want to transmit

NBITEN: Nine-BIT mode Enable Bit

0 = Eight-bit mode

1 = Nine-bit mode

UTEN: UART Enable Bit

0 = Disable UART module

1 = Enable UART module

UTTXINV: Transmit Invert Selection Bit

0 = Transmitter output without inverted

1 = Transmitter output inverted

UTRXINV: Receive Invert Selection Bit

0 = Receiver input without inverted

1 = Receiver input inverted

TXIE: Transmit Interrupt Enable

0 = Transmit interrupt disable

1 = Transmit interrupt enable

RXIE: Receive Interrupt Enable

0 = Receiver interrupt disable

1 = Receiver interrupt enable

Register 8-2 UARTSTA – UART0 status

Position	7	6	5	4	3	2	1	0
Name	UTRXNB	FEF	RXIF	TXIF	-	-	-	PSEL
Default	x	x	0	1	-	-	-	0
Access	R/W	R/W	R/W	RO	-	-	-	R/W

UTRXNB: The ninth bit data of receiver buffer

FEF: Frame Error Flag

0 = the stop bit is '1' in the last received frame

1 = the stop bit is '0' in the last received frame

RXIF: RX Interrupt Flag

0 = RX not done

1 = RX done

TXIF: TX Interrupt Flag

0 = TX not done

1 = TX done

Writing data to UTBUF will clear this flag.

PSEL: UART0 Port Select

0 = Select UART0RX0 and UART0TX0

UART0RX0: P34

UART0TX0: P16

1 = Select UART0RX1 and UART0TX1

UART0RX1: P00

UART0TX1: P01

Register 8-3 UARTBAUDL – UART0 Baud Rate Low Byte

Position	7	6	5	4	3	2	1	0
Name	UARTBAUDL							
Default	x	x	x	x	x	x	x	x
Access	WO	WO	WO	WO	WO	WO	WO	WO

Register 8-4 UARTBAUDH – UART0 Baud Rate High Byte

Position	7	6	5	4	3	2	1	0
Name	UARTBAUDH							
Default	0	0	0	0	0	0	0	0
Access	WO	WO	WO	WO	WO	WO	WO	WO

UARTBAUD = {UARTBAUDH, UARTBAUDL}

Register 8-5 UARTDIV

Position	7	6	5	4	3	2	1	0
Name	UARTDIV							
Default	0	0	0	0	0	0	0	0
Access	WO	WO	WO	WO	WO	WO	WO	WO

Baud Rate = $F_{\text{sys clock}} / [(UARTBAUD + 1) \times (UARTDIV + 1)]$

Register 8-6 UARTDATA – UART0 Data

Position	7	6	5	4	3	2	1	0
Name	UARTDATA							
Default	x	x	x	x	x	x	x	x
Access	R/W	R/W	R/W	R/W	R/W	R/W	R/W	R/W

Write this location will load the data to transmitter buffer. And read this location will read the data from the receiver

buffer.

8.2 UART1

8.2.1 Overview

UART1 is a serial port capable of asynchronous transmission. The UART1 can function in normal and DMA full duplex mode. Please see PMUXCON0 bit 6 descriptions

when PMUXCON0[6] == 0

- Receive pin (RX) – UART1RX0 (P17)
- Transmit pin (TX) – UART1TX0 (P16)

Or PMUXCON0[6] == 1

- Receive pin (RX) – UART1RX1 (BT_TX)
- Transmit pin (TX) – UART1TX1 (BT_RX)

8.2.2 UART1 Special Function Registers

Register 8-7 UART1CON – UART1 control

Position	7	6	5	4	3	2	1	0
Name	UTSBS	UTTXNB	NBITEN	UTEN	TXIE	RXIE	OVERFLOWIE	DMASEL
Default	0	1	0	0	0	0	-	0
Access	R/W	R/W	R/W	R/W	R/W	R/W	-	R/W

UTSBS: Stop Bit Select

0 = 1 bit as Stop Bit

1 = 2 bits as Stop Bit

UTTXNB: The ninth bit data of transmitter buffer. Write the ninth bit into this location that you want to transmit

NBITEN: Nine-BIT mode Enable Bit

0 = Eight-bit mode

1 = Nine-bit mode

UTEN: UART Enable Bit

0 = Disable UART module

1 = Enable UART module

TXIE: Transmit Interrupt Enable

0 = Transmit interrupt disable

1 = Transmit interrupt enable

RXIE: Receive Interrupt Enable

0 = Normal Receive interrupt disable or AUTO DMA mode Receive one word Interrupt disable

1 = Normal Receive interrupt enable or AUTO DMA mode Receive one word Interrupt enable

OVERFLOWIE: Receive DMA overflow interrupt enable

0 = overflow Interrupt disable

1 = overflow Interrupt enable

DMASEL:AUTO DMA choose

0 = AUTO DMA mode off

1= AUTO DMA mode on

Register 8-8 UART1STA – UART1 status

Position	7	6	5	4	3	2	1	0
Name	UART_GIIE	-	UTRXNB	RX_BYTE_HIGH	RXIF	TXIF	OVERFLOWIF	RXKICK
Default	0	-	x	0	0	1	0	0
Access	R/W	-	R/W	RO	R/W	R/W	R/W	WO

UART_GIE:UART Global Interrupt 15 Enable

0 = UART Global I Interrupt disable

1 = UART Global I Interrupt enable

UTRXNB: The ninth bit data of receiver buffer

RX_BYTE_HIGH : receive data high byte(only for DMA)

0 = waiting receive data low byte

1 = waiting receive data high byte

RXIF: UART RX Interrupt Flag

0 = Normal Receive or AUTO DMA mode Receive one word not done

1 = Normal Receive or AUTO DMA mode Receive one word done

In normal mode, it becomes “1” every byte, but in DMA mode, it becomes “1” every word.

TXIF: UART TX Interrupt Flag

0 = UART transmit not done

1 = UART transmit done

Writing data to UTBUF or Writing UARTDMATXCNT will clear this flag.

OVERFLOWIF: UART overflow Interrupt Flag

0 = UART overflow not done

1 = UART overflow done

RXKICK: UART DMA receive KICK start

0 = not KICK start

1 = KICK start

Register 8-9 UART1DIV – UART1 divide register

Position	7	6	5	4	3	2	1	0
Name	UART1DIV							
Default	0	0	0	0	0	0	0	0
Access	R/W	R/W	R/W	R/W	R/W	R/W	R/W	R/W

Register 8-10 UART1BAUD – UART1 Baud Rate register

Position	7	6	5	4	3	2	1	0
Name	UART1BAUD							
Default	x	x	x	x	x	x	x	x
Access	WO	WO	WO	WO	WO	WO	WO	WO

Baud Rate = Fsys clock / [(UARTDIV+1) (UART1BAUD + 1)]

Register 8-11 UART1DATA – UART1 Data

Position	7	6	5	4	3	2	1	0
Name	UART1DATA							
Default	x	x	x	x	x	x	x	x
Access	R/W	R/W	R/W	R/W	R/W	R/W	R/W	R/W

Write this location will load the data to transmitter buffer. And read this location will read the data from the receiver buffer.

Register 8-12 UARTDMATXCNT –UART1 DMA Transmit counter

Portion	7	6	5	4	3	2	1	0
Name	UARTDMATXCNT							
Default	x	x	x	x	x	x	X	x
Access	WO	WO	WO	WO	WO	WO	WO	WO

Nbyte = UARTDMATXCNT + 1

Register 8-13 UARTDMATXPTR–UART1 DMA Transmit Start Pointer byte

Portion	7	6	5	4	3	2	1	0
Name	UARTDMATXPTR							
Default	x	x	x	X	x	x	X	x
Access	WO	WO	WO	WO	WO	WO	WO	WO

In order to get the correct DMA Start Pointer, you should write this register twice. First write the higher byte, then the low byte. DMA address only map to SRAM1.

Register 8-14 UARTDMARXPTR–UART1 DMA receive Start Pointer byte

Portion	7	6	5	4	3	2	1	0
Name	UARTDMARXPTR							
Default	x	x	x	X	x	x	X	x
Access	WO	WO	WO	WO	WO	WO	WO	WO

In order to get the correct DMA Start Pointer , you should write this register twice. First write the higher byte, then the low byte. DMA address only map to SRAM1.

Register 8-15 UART1MINUS–UART1 DMA receive data minus byte count by CPU

Portion	7	6	5	4	3	2	1	0
Name	UART1MINUS							
Default	x	x	x	X	x	x	X	x

Access	WO	WO	WO	WO	WO	WO	WO	WO
--------	----	----	----	----	----	----	----	----

Nbyte = UART1MINUS+ 1'b1

Register 8-16 UART1POINTL–UART DMA point by CPU read

Portion	7	6	5	4	3	2	1	0
Name	UART1POINTL							
Default	x	x	x	X	x	x	X	x
Access	R/O	R/O	R/O	R/O	R/O	R/O	R/O	R/O

Register 8-17 UART1POINTH–UART DMA point by CPU read high byte

Portion	7	6	5	4	3	2	1	0
Name	UART1POINTH							
Default	x	x	x	X	x	x	X	x
Access	R/O	R/O	R/O	R/O	R/O	R/O	R/O	R/O

Register 8-18 UART1LOOPCNT–UART1 DMA loop count

Position	7	6	5	4	3	2	1	0
Name				overflowcnt		dma_loop_cnt		
Default				0	0	0	0	0
Access	WO	WO	WO	WO	WO	WO	WO	WO

overflowcnt: less than bytes UART receive data ram size

00 = 4 bytes

01 = 8 bytes

10 = 16 bytes

11 = 32 bytes

dma_loop_cnt:UART receive data ram size

000 = 16 bytes

001 = 32 bytes

010 = 64 bytes

011 = 128 bytes

100 = 256 bytes

101 = 512 bytes

110 = 1K bytes

111 = forbidden

Register 8-19 UART1CNTH–UART1 DMA receive count high byte

Portion	7	6	5	4	3	2	1	0
Name	UART1CNTH							
Default	x	x	x	X	x	x	X	x
Access	R/O	R/O	R/O	R/O	R/O	R/O	R/O	R/O

Register 8-20 UART1CNTL–UART1 DMA receive count low byte

Portion	7	6	5	4	3	2	1	0
Name	UART1CNTL							
Default	x	x	x	x	x	x	x	x
Access	R/O	R/O	R/O	R/O	R/O	R/O	R/O	R/O

8.3 Operation Guide

1) UART1 Normal mode Operation Flow:

1. Set IO in the correct direction.
2. Configure UARTDIV and UART1BAUD to choose sample rate and baud.
3. Enable UART1 module by setting UTEN to '1'
4. Set TXIE or RXIE 'to 1' if needed
5. Write data to UART1DATA
6. Wait for PND to change to '1', or wait for interrupt
7. Read received data from UART1DATA if needed
8. Go to Step 5 to start another process if needed or turn off UART1 by UTEN.

2) UART1 DMA Mode Operation Flow:

1. Set IO in the correct direction.
2. Configure UARTDIV and UART1BAUD to choose sample rate and baud.
3. Configure UART1CON Select DMA.
4. Write the start DMA address. for receive, Write data to UARTDMARXPTR
5. Enable UART module by setting UTEN to '1'.
6. kick-start a DMA receive process
7. Wait overflow or delay some time ,read UART1CNTH and UART1CNTL,read data by write UART1MINUS (UART1MINUS<{UART1CNTH,UART1CNTL}).
8. Write the start DMA address. for transmission, Write data to UARTDMATXPTR
9. Write data to UARTDMATXCNT to kick-start a DMA transmit process
10. Wait for PND to change to '1', or wait for interrupt

8.4 BT Control Register

Register 8-21 BTCON1 – BT control register1

Position	7	6	5	4	3	2	1	0
Name			BTC2RS	BTCCLKO	BTCCLKI	BTRSTB	Reserved	XOSC26MEN
Default	0	0	0	0	0	0	0	0
Access	R/W	R/W	R/W	RO	R/W	R/W	R/W	R/W

BTC2RS: BTCON2 read select

0 = read BTCONT register

1 = read BT output state

BTCCLKO: BT CDCLK output state

BTCCLKI: BT CDCLK input state

XOSC26MEN: BT xosc26M enable

0 = disable

1 = enable

Register 8-22 BTCON2 – BT control register2

Position	7	6	5	4	3	2	1	0
Name	BTTX	BTRX	BTCTS	BTTESTEN	BTGPIO10	BTGPIO9	BTGPIO5	BTGPIO4
Default	0	0	0	0	0	0	0	0
Access	R/W	R/W	R/W	R/W	R/W	R/W	R/W	R/W

write: write date to BT

read: depend on BTCON1[5]

9 Direct Memory Access (DMA)

9.1 DMA for IRAM

There is a DMA Arbiter to schedule all the DMA access to IRAM, it provide 12 DMA channels for IRAM DMA.

The following peripherals support IRAM DMA (Priority from high to low).

1. USB
2. SDC
3. UART1
4. Bit fetcher
5. SPI1
6. AGC
7. IIS
8. SPI0
9. FFT
10. Key Tone

For IRAM access, the DMA Arbiter has higher priority than CPU MOVX, MOVC and instruction code fetching. So DMA will not be interrupted by CPU read or write on-chip SRAM. When DMA is transferring and a CPU access occurs, the CPU will hold on the current accessing and try again next clock cycle.

9.2 DMA for RAM2

There is a DMA Arbiter to schedule all the DMA access to RAM2, it provide 7 DMA channels for RAM2 DMA.

The following peripherals support RAM2 DMA (Priority from high to low).

1. USB
2. Output Buffer
3. SDC
4. SPI0
5. SPI1
6. Uart1
7. IIS

For RAM2 access, the DMA Arbiter has higher priority than CPU MOVX, MOVC and instruction code fetching. So DMA will not be interrupted by CPU read or write on-chip SRAM. When DMA is transferring and a CPU access occur, the CPU will hold on the current accessing and try again next clock cycle.

9.3 DMA for DEGRAM

There is a DMA Arbiter to schedule all the DMA access to DEGRAM, it provide 5 DMA channels for DEGRAM DMA.

The following peripherals support DEGRAM DMA (Priority from high to low).

1. Huffman
2. Audio decode buffer
3. SDC
4. SPI0
5. IIS

For DEGRAM access, the DMA Arbiter has higher priority than CPU MOVX, MOVC and instruction code fetching. So DMA will not be interrupted by CPU read or write on-chip SRAM. When DMA is transferring and a CPU access occur, the CPU will hold on the current accessing and try again next clock cycle.

9.4 DMA for IROM

There is a DMA Arbiter to schedule all the DMA access to IROM, it provide 1 DMA channel for IROM DMA.

The following peripherals support IROM DMA (Priority from high to low).

1. Huffman decoder

For IROM access, the DMA Arbiter has higher priority than CPU MOVC and instruction code fetching. So DMA will not be interrupted by CPU read IROM. When DMA is transferring and a CPU access occur, the CPU will hold on the current accessing and try again next clock cycle.

10 IR receiver

CW6687B provides a digital IR receiver, it can receive IR data followed by CPU, it also can read IR data from the IR data buffer.

10.1 IR frame format

Figure 10-1 shows the IR data frame format

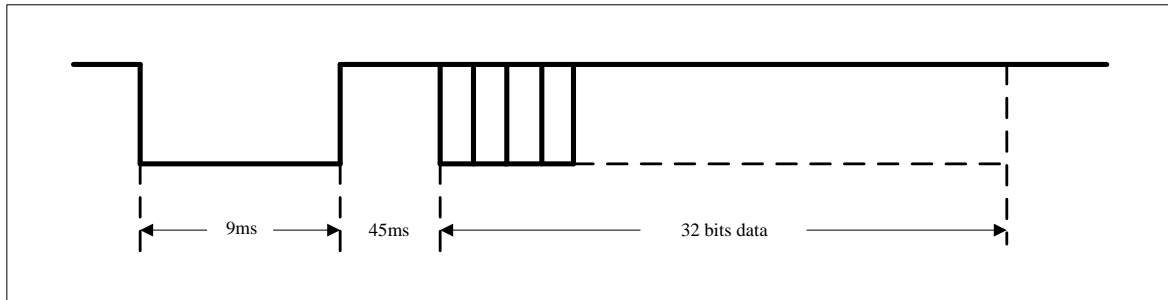

Figure 10-1 IR data frame format

Figure 10-2 shows the IR repeat frame format

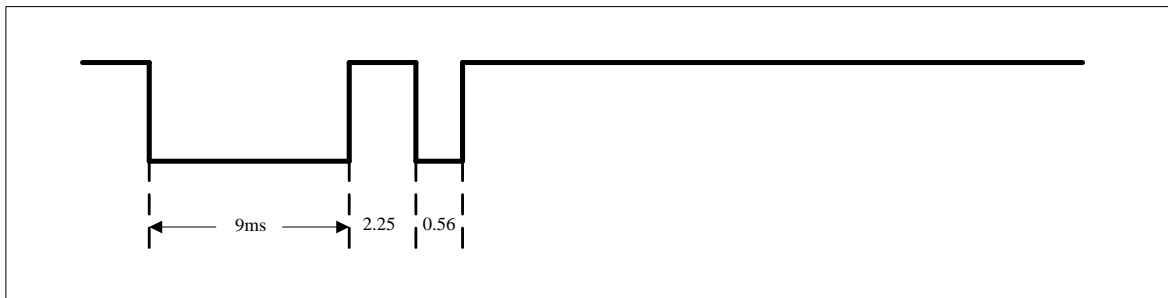

Figure 10-2 IR repeat frame format

Figure 10-3 shows the IR bit 0 and bit 1 format

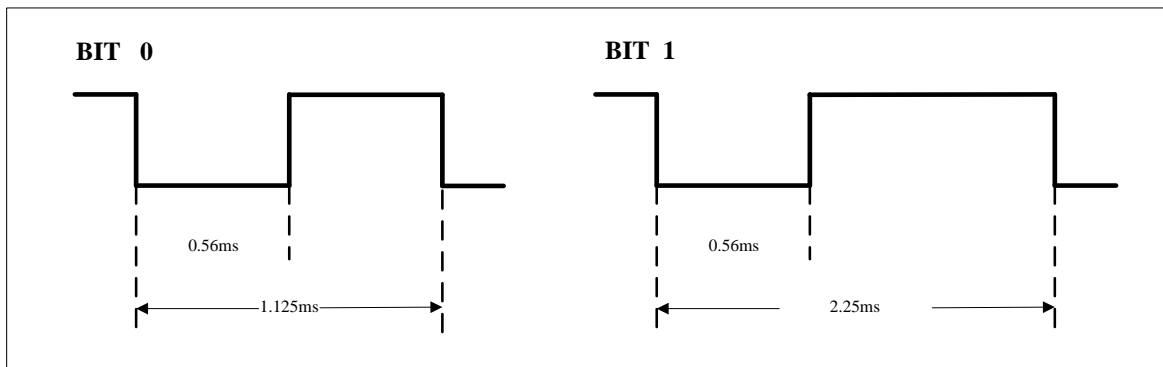

Figure 10-3 IR bit frame format

10.2 IR Receiver Control Registers

Register 10-1 IRCON0 - IR receiver control 0 register

Position	7	6	5	4	3	2	1	0
Name	-	-	-	IRPINSEL	IRREPEAT	IRPND	IRIE	IREN
Default	0	0	0	0	0	0	0	0
Access	RO	RO	RO	R/W	RO	R/W	R/W	R/W

IRPINSEL: IR input pin select

0 = P07 as IR receiver input

1 = P33 as IR receiver input

IRREPEAT: IR receiver repeating data

0 = Not repeat

1 = Repeat

IRPND: IR receiver done

0 = Undone

1 = Done

IRIE: IR interrupt enable

0 = Disabled

1 = Enabled

IREN: IR enable

0 = Disabled

1 = Enabled

Register 10-2 IRCON1 - IR receiver control 1 register

Position	7	6	5	4	3	2	1	0
Name	IRCON1							
Default	0	0	0	0	0	0	0	0
Access	WO	WO	WO	WO	WO	WO	WO	WO

The IRCON1 is the entrance for five 8-bit control registers: ONEFULL, ZEROCYC, REPEATCNT, ENDCONT and BEGNCNT. And IRCON1 must be written five times to update all the five control registers.

First time for the **ONEFULL**.

Position	7	6	5	4	3	2	1	0
Name	ONEFULL							
Default	1	0	0	1	1	1	0	0

When IR clock is 1 MHz, $ONEFULL * 16 * CLKCYC$ us is the time of IRDATA error. It is recommended to set ONEFULL to 0x9C. (**NOTE:** $ONEFULL * 16 > BIT$ 1 cycle),

When IR clock is 32 KHz, $ONEFULL * CLKCYC$ us is the time of IRDATA error. It is recommended to set ONEFULL to 0x5E (**NOTE:** $ONEFULL * 8 > BIT$ 1 cycle)

Second time for the **ZEROCYC**.

Position	7	6	5	4	3	2	1	0
Name	ZEROCYC							

Default	0	1	0	1	0	0	0	0
---------	---	---	---	---	---	---	---	---

When IR clock is 1 MHz, ZEROCYC*16*CLKCYC us is the cycle of IR BIT 0 and BIT 1 division. It is recommended to set ZEROCYC to 0x50. (**NOTE:** BIT 0 cycle < ZEROCYC*8 < BIT 1 cycle)

When IR clock is 32 KHz, ZEROCYC*CLKCYC us is the cycle of IR BIT 0 and BIT 1 division. It is recommended to set ZEROCYC to 0x28 (**NOTE:** BIT 0 cycle < ZEROCYC < BIT 1 cycle)

Third time for the **REPEATCNT**.

Position	7	6	5	4	3	2	1	0
Name	REPEATCNT							
Default	0	0	0	0	0	1	0	0

When IR clock is 1 MHz, REPEATCNT*512*CLKCYC us is the IR repeat pulse (2.3ms). It is recommended to set REPEATCNT to 0x04.

When IR clock is 32 KHz, REPEATCNT*32*CLKCYC us is the IR repeat pulse (2.3ms). It is recommended to set REPEATCNT to 0x02.

Fourth time for the **ENDCNT**.

Position	7	6	5	4	3	2	1	0
Name	ENDCNT							
Default	1	0	0	0	0	0	0	0

When IR clock is 1 MHz, ENDCNT *512*CLKCYC us is the IR incept high (4ms). It is recommended to set ENDCNT to 0x08.

When IR clock is 32 KHz, ENDCNT *32*CLKCYC us is the IR incept high (4ms). It is recommended to set ENDCNT to 0x09.

Fifth time for the **BEGINCNT**.

Position	7	6	5	4	3	2	1	0
Name	BEGINCNT							
Default	0	0	0	1	0	0	0	1

When IR clock is 1 MHz, BEGINCNT * 512*CLKCYC us is the IR incept low (9ms). It is recommended to set BEGINCNT to 0x11.

When IR clock is 32 KHz, BEGINCNT *32*CLKCYC us is the IR incept low (9ms). It is recommended to set BEGINCNT to 0x08.

NOTE: When IR clock is 1 MHz and BEGINCNT or ENDCNT or REPEATCNT is configured to N, the detect range is $N*512*cycle \sim (N*512+511)*cycle$.

NOTE: when IR clock is 32 KHz and BEGINCNT or ENDCNT or REPEATCNT is configured to N, the detect range is $N*32*cycle \sim (N*32+31)*cycle$

Register 10-3 IRDAT0 - IR receiver data buffer0 register

Position	7	6	5	4	3	2	1	0
Name	IRDAT0							
Default	0	0	0	0	0	0	0	0
Access	RO	RO	RO	RO	RO	RO	RO	RO

Register 10-4 IRDAT1 - IR receiver data buffer1 register

Position	7	6	5	4	3	2	1	0
Name	IRDAT1							
Default	0	0	0	0	0	0	0	0
Access	RO	RO	RO	RO	RO	RO	RO	RO

Register 10-5 IRDAT2 - IR receiver data buffer2 register

Position	7	6	5	4	3	2	1	0
Name	IRDAT2							
Default	0	0	0	0	0	0	0	0
Access	RO	RO	RO	RO	RO	RO	RO	RO

Register 10-6 IRDAT3 - IR receiver data buffer3 register

Position	7	6	5	4	3	2	1	0
Name	IRDAT3							
Default	0	0	0	0	0	0	0	0
Access	RO	RO	RO	RO	RO	RO	RO	RO

10.3 IR Receiver Operation Guide

1. Configure IR clock (CLKCON2);
2. Configure IRCON1 if needed;
3. Configure IRCON0;
4. Wait IRPND or IR interrupt;
5. Read IRDAT0/1/2/3.

11 SPI

11.1 SPI0

SPI0 can serve as master or slave. It can operate in normal or DMA mode.

SPI0 map to three group ports configured by PWKEDGE[6] and SPICON[3]:

Group0 - P27, P25, P26;

Group1 - P04, P06, P05;

Group2 - P14, P00, P34.

Group3 - P30(P40), P31, P32

When PWKEDGE[6]=0 and SPI0CON.3 = 0, Group0 activated

- 2wire mode: P2.6 as SPI0CLK0, P2.7 as SPI0DIDO0;
- 3wire mode: P2.6 as SPI0CLK0, P2.7 as SPI0DO2, P2.5 as SPI0DI0.

When PWKEDGE[6]=0 and SPI0CON.3 = 1, Group1 activated

- 2wire mode: P0.5 as SPI0CLK1, P0.4 as SPI0DIDO1;
- 3wire mode: P0.5 as SPI0CLK1, P0.4 as SPI0DO1, P0.6 as SPI0DI1.

When PWKEDGE[6]=1 and SPI0CON.3 = 0 Group2 activated

- 2wire mode: P3.4 as SPI0CLK2, P1.4 as SPI0DIDO2;
- 3wire mode: P3.4 as SPI0CLK2, P1.4 as SPI0DO2, P0.0 as SPI0DI2.

When PWKEDGE[6]=1 and SPI0CON.3 = 1, Grop3 activated

- 2wire mode: P3.0 as SPI0CLK3, P3.2 as SPI0DIDO3;
- 3wire mode: P3.0 as SPI0CLK3, P3.2 as SPI0DO3, P3.1 as SPI0DI3.
- when PMUXCON0[5] = 1 P4.0 as SPI0CLK3

11.1.1 SPI0 Special Function Registers

Register 11-1 SPI0CON – SPI0 control

Position	7	6	5	4	3	2	1	0
Name	SPI0PND	SPI0SM	SPI0RT	SPI0WS	SPI0PS0	SPI0EDGE	SPI0DST	SPI0EN
Default	1	0	0	0	0	0	0	0
Access	RO	R/W	R/W	R/W	R/W	R/W	R/W	R/W

SPI0PND: SPI0 Pending bit (read only, writing SPI0BUF will clear this bit)

0 = Transmission is not finish

1 = Transmission finish

SPI0SM: SPI0 mode selection

0 = Master mode

1 = Slave mode

SPI0RT: SPI0 RX/TX select bit in 2-wire mode or DMA mode

0 = TX

1 = RX

In 3-wire mode, SPI0 can both Transmit and receive at the same time. But when using DMA mode or 2-wire mode, just one direction (TX or RX) is allowed. Use this bit to select TX or RX.

SPI0WS: SPI0 2-wire mode/3-wire mode select bit

0 = 3-wire mode

1 = 2-wire mode

SPI0PS0: SPI0 Port select 0

0 = Select P27, P25, P26 when SPI0PS1 = 0; Select P14, P00, P34 when SPI0PS1 = 1

1 = Select P04, P06, P05 when SPI0PS1 = 0

SPI0EDGE: SPI0 sampling edge select bit

When SPI0IDST = 0:

0 = Sample at falling edge

1 = Sample at rising edge

When SPI0IDST = 1:

0 = Sample at rising edge

1 = Sample at falling edge

SPI0IDST: SPI0 clock signal idle state

0 = Clock signal stays at 0 when idle

1 = Clock signal stays at 1 when idle

SPI0EN: SPI0 enable bit

0 = SPI0 disable

1 = SPI0 enable

Register 11-2 SPIBAUD – SPI0 Baud Rate

Position	7	6	5	4	3	2	1	0
Name	SPIBAUD							
Default	x	x	x	x	x	x	x	x
Access	WO	WO	WO	WO	WO	WO	WO	WO

$$\text{Baud rate} = F_{\text{system_clock}} / [2(\text{SPIBAUD}+1)]$$

Register 11-3 SPI0BUF – SPI0 Data Buffer

Position	7	6	5	4	3	2	1	0
Name	SPI0BUF							
Default	x	x	x	x	x	x	x	X
Access	R/W	R/W	R/W	R/W	R/W	R/W	R/W	R/W

Register 11-4 SPIDMACNT – SPI0 DMA counter

Position	7	6	5	4	3	2	1	0
Name	SPIDMACNT							
Default	x	x	x	x	x	x	x	x
Access	WO	WO	WO	WO	WO	WO	WO	WO

Nunit = SPIDMACNT + 1

Nbyte = Nunit * 2 = (SPIDMACNT + 1) * 2

Register 11-5 SPIDMAPTRH– SPI0 DMA Start Pointer high byte

Position	7	6	5	4	3	2	1	0
Name	SPIDMAPTRH							
Default	x	x	x	x	x	x	x	x
Access	WO	WO	WO	WO	WO	WO	WO	WO

Register 11-6 SPIDMAPTRL– SPI0 DMA Start Pointer low byte

Position	7	6	5	4	3	2	1	0
Name	SPIDMAPTRL							
Default	x	x	x	x	x	x	x	x
Access	WO	WO	WO	WO	WO	WO	WO	WO

11.1.2 SPI0 Operation Guide

When SPI0CON1.1=0,

SPI0 Normal Mode Operation Flow:

1. Set IO in the correct direction.
2. Select SPI0RT in 2-wire mode if 2-wire mode is selected
3. Select master mode or slave mode
4. Configure clock frequency when master mode is selected in step 3
5. Select one of the four timing modes
6. Enable SPI0 module by setting SPI0EN to '1'
7. Set SPI0IE to '1' if needed
8. Write data to SPI0BUF to kick-start the process
9. Wait for SPI0PND to change to '1', or wait for interrupt
10. Read received data from SPI0BUF if needed
11. Go to Step 8 to start another process if needed or turn off SPI0 by clearing SPI0IE and SPI0EN

SPI0 DMA Mode Operation Flow:

1. Set IO in the correct direction.
2. Select SPI0RT for DMA direction
3. Select master mode or slave mode
4. Configure clock frequency when master mode is selected in step 3

5. Select one of the four timing modes
6. Enable SPI0 module by setting SPI0EN to '1'
7. Set SPI0IE '1' if needed
8. Write the start address to SPI0DMASP
9. Write data to SPI0DMACNT to kick-start a DMA process
10. Wait for SPI0PND to change to '1', or wait for interrupt
11. Go to Step 8 to start another DMA process if needed or turn off SPI0 by clearing SPI0IE and SPI0EN

11.2 SPI1

CW6687B SPI1 is an accelerated SPI. It can serve as master only. It can operate in normal or DMA mode. Please see PMUXCON0 bit 5 descriptions

SPI1 uses 2 pins for 2 wire mode:

- Serial Data (SPIDIDO1) - P04
- Serial Clock (SPICLK1) - P05

SPI1 uses 3 pins for 3 wire mode:

When SPI1_MAP = 0,

- Serial Data Out (SPIDO1) - P04
- Serial Data In (SPIDI1) - P06
- Serial Clock (SPICLK1) - P05

When SPI1_MAP = 1,

- Serial Data Out (SPIDO0) - P04
- Serial Data In (SPIDI0) - P42
- Serial Clock (SPICLK0) - 05

11.2.1 SPI1 Special Function Registers

Register 11-7 SPI1CON – SPI1 Configure Register

Position	7	6	5	4	3	2	1	0
Name	SPI1PND	DMAERR	SPI1RT	SPI1WS	SPI1DEC			SPI1EN
Default	1	0	0	0	0	0	0	0
Access	R/W	R/W	R/W	R/W	R/W	RO	RO	R/W

SPI1PND: SPI1 Pending bit (read only, writing SPI1BUF will clear this bit)

0 = Transmission has not finished

1 = Transmission finish

DMAERR: SPI1 DMA Error flag

0 = No DMA error

1 = DMA error happened.

SPI1RT: SPI1 RX/TX select bit in 2-wire or DMA mode

0 = TX

1 = RX

In 3-wire mode, SPI1 can both Transmit and receive at the same time. But if we use DMA mode or 2-wire mode, just one direction (TX or RX) is allowed. Use this bit to select TX or RX.

SPI1WS: SPI1 2-wire mode/3-wire mode select bit

0 = 3-wire mode

1 = 2-wire mode

SPI1DEC: SPI1 decryption function enables

0 = Disabled

1 = Enabled

SPI1EN: SPI1 enable bit

0 = SPI1 disabled

1 = SPI1 enabled

Register 11–8 SPI1CON1 – SPI1 Configure Register1

Position	7	6	5	4	3	2	1	0
Name	-	-	-	-	-	-	CRCEN	ENCRYPT
Default	-	-	-	-	-	-	0	0
Access	-	-	-	-	-	-	R/W	R/W

CRCEN: SPI1 CRC enable when SPI1 receiving data

0 = Disabled

1 = Enabled

ENCRYPT: SPI1 output encryption function enable

0 = Disabled

1 = Enabled

NOTE: *ENCRYPT and SPI1DEC cannot be 1 at the same time.*

Register 11–9 SPI1BUF – SPI1 Data Buffer

Position	7	6	5	4	3	2	1	0
Name	SPI1BUF							
Default	X	x	x	x	x	x	x	X
Access	R/W	R/W	R/W	R/W	R/W	R/W	R/W	R/W

Write this location to load the data to transmitter buffer and kick start the SPI transmission, read this location to read the data from the receiver buffer.

Register 11–10 SPI1DMASPH– SPI1 DMA Pointer

Position	7	6	5	4	3	2	1	0
Name	-	-	SPI1DMASPH					
Default	0	0	x	x	x	x	x	x
Access	-	-	WO	WO	WO	WO	WO	WO

SPI DMA start address pointer, point to the start address in IRAM that the data to be transmitted or data to be stored.

Register 11–11 SPI1DMASPL– SPI1 DMA Pointer

Position	7	6	5	4	3	2	1	0
Name	SPI1DMASPL							
Default	x	x	x	x	x	x	x	x
Access	WO	WO	WO	WO	WO	WO	WO	WO

Register 11–12 SPI1DMACNTH – SPI1 DMA Counter High byte

Position	7	6	5	4	3	2	1	0
Name	SPI1DMACNTH							
Default	X	X	x	X	x	x	x	x
Access	WO	WO	WO	WO	WO	WO	WO	WO

Register 11–13 SPI1DMACNTL – SPI1 DMA Counter Low Byte

Position	7	6	5	4	3	2	1	0
Name	SPI1DMACNTL							
Default	X	x	x	x	x	x	x	x
Access	WO	WO	WO	WO	WO	WO	WO	WO

SPI DMA counter, decide the amount of units to be transmitted or received. There are 2 bytes in a unit. DMA counter ranges from 0 to 2047 words. Formula is as follows:

$$\text{SPIDMACNT} = \{\text{SPIDMACNTH}, \text{SPIDMACNTL}\}$$

$$\text{Nunit} = \text{SPIDMACNT} + 1$$

$$\text{Nbyte} = \text{Nunit} * 2 = (\text{SPIDMACNT} + 1) * 2$$

Write this location to enable DMA and kick start a DMA process .Caution: do not write 0 to this register.

Note: Must write SPIDMACNTH, then SPIDMACNTL, this order can't change !

Register 11–14 SPI1BAUD – SPI1 BAUD RATE

Position	7	6	5	4	3	2	1	0
Name	SPI1BAUD							
Default	0	0	0	0	0	0	0	0
Access	R/W	R/W	R/W	R/W	R/W	R/W	R/W	R/W

SPI Baud Rate, from 0 to 255

SPI Clock is System Clock / (SPI1BAUD + 1) , If SPI1BAUD is 0, then SPI Clock is same as System Clock.

11.2.2 SPI1 Operation Guide

A. SPI Normal Mode Operation Flow:

1. Set IO in the correct direction.
2. Select SPI1WS in 2-wire mode or 3 wire mode.
3. Select SPI1RT for reception or transmission.
4. Configure clock frequency using bit SPI1SP.
5. Enable SPI module by setting SPI1EN '1'
6. Set SPI1IE '1' if needed

-
7. Write data to SPI1BUF to kick-start the process
 8. Wait for SPI1PND change to '1', or wait for interrupt
 9. Read received data from SPI1BUF if needed
 10. Go to Step 7 to start another process if needed or turn off SPI1 by clearing SPI1PND and SPI1EN

B. SPI DMA Mode Operation Flow:

1. Set IO in the correct direction.
2. Select SPI1RT for DMA direction
3. Select SPI1WS in 2-wire mode or 3 wire mode
4. Configure clock frequency using bit SPI1SP
5. Enable SPI module by setting SPI1EN '1'
6. Set SPI1IE '1' if needed
7. Write the start address to SPI1DMASP
8. Write data to SPI1DMACNT to kick-start the DMA process.
9. Wait for bit SPI1PND to change to '1', or wait for interrupt
10. Go to Step 7 to start another DMA process if needed or turn off SPI by clearing SPI1PND and SPI1EN

12 External Memory Interface (EMI)

CW6687B provides External Memory Interface (EMI) to accelerate data transfer. [Figure 12-1](#) shows EMI timing.

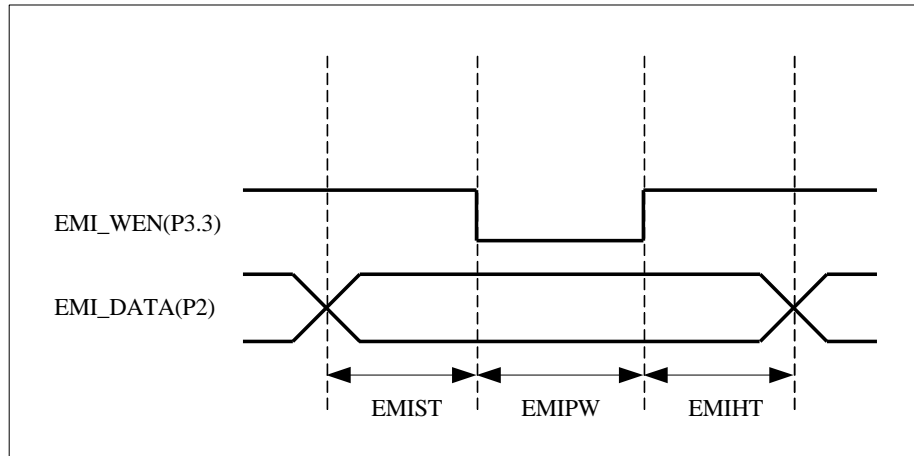

Figure 12-1 EMI timing

12.1 EMI Control Registers

Register 12-1 EMICON0 – EMI control0

Position	7	6	5	4	3	2	1	0
Name	EMIEN	EMIPW			EMIHT		EMIST	
Default	1	0	0	0	0	0	0	0
Access	R/W	R/W	R/W	R/W	R/W	R/W	R/W	R/W

EMIEN:

When writing: EMI Enable

0 = Disable

1 = Enable

EMIPW: EMI pulse width

000 = 1 system clock cycle

001 = 2 system clock cycles

010 = 3 system clock cycles

011 = 4 system clock cycles

100 = 5 system clock cycles

101 = 6 system clock cycles

110 = 7 system clock cycles

111 = 8 system clock cycles

EMIHT: EMI hold time

00 = 1 system clock cycle

01 = 2 system clock cycles

10 = 3 system clock cycles

11 = 4 system clock cycles

EMIST: EMI setup time

00 = 1 system clock cycle

01 = 2 system clock cycles

10 = 3 system clock cycles

11 = 4 system clock cycles

Register 12-2 EMICON1 – EMI control1

Position	7	6	5	4	3	2	1	0
Name	EMIPND		OUTSEL	PWMEN	EMIDMAB		EMIDMAM	EMIM
Default	1	0	0	0	0	0	0	0
Access	RO	R/W	R/W	R/W	R/W	R/W	R/W	R/W

EMIPND: When Read EMI done flag

0 = EMI is transmitting data

1 = EMI is IDLE

When writing “0”, clear write buffer counter; write to “1” affect another

OUTSEL: PWM output select

0 = LED anode display

1 = LED cathode display

PWMEN: PWM enable

0 = Disable

1 = Enable

EMIDMAB: EMI DMA converts byte select

00 = reserved

01 = 1 byte

10 = 2 byte

11 = 3 byte

EMIDMAM: EMI DMA mode

0 = no convert

1 = bit convert to byte

EMIM: EMI mode

0 = work when CPU kick start

1 = work with SPI1 DMA

Register 12-3 EMIBUF – EMI output buffer

Position	7	6	5	4	3	2	1	0
Name	EMIBUF							
Default	x	x	x	x	x	x	x	x
Access	WO	WO	WO	WO	WO	WO	WO	WO

EMIBUF is the entrance of 6 bytes EMI output buffer. The 6 bytes EMI output buffer is emibuf0, emibuf1, emibuf2, emibuf3, emibuf4 and emibuf5. When CPU writes to EMIBUF, internal counter will add "1", CPU data is pushed to corresponding buffer. You should clear internal counter by writing "0" to emicon1 bit 7;

PWM mode: should write eight times for eight channels PWM of P2

When EMIM = 0, emibuf0 will output to P2. Emibuf0 is updated with CPU write data.

When EMIM = 1 and in no convert mode, emibuf0 will output to P2. Emibuf0 is updated with SPI1 DMA data.

When SPI2EMI = 1 and in convert mode, there are 3 output modes:

Register 12-4 PMWBUF0/1/2/3/4/5/6/7 – PWM duty buffer0/1/2/3/4/5/6/7

Position	7	6	5	4	3	2	1	0
Name	PWMBUF0/1/2/3/4/5/6/7							
Default	x	x	x	x	x	x	x	x
Access	WO	WO	WO	WO	WO	WO	WO	WO

This register config PWM duty.

PWM period is config by EMICON0[3:0] and EMICON0[6:4]. PWM period = pre counter * post counter * system clock

EMICON0[6:4]: config pwm output period post counter

000 = 2

001 = 4

010 = 8

011 = 16

100 = 32

101 = 64

110 = 128

111 = 256

EMICON0[3:0]: config pwm output period pre counter

0xxx = 1

1000 = 2

1001 = 4

1010 = 8

1011 = 16

1100 = 32

1101 = 64

1110 = 128

1111 = 256

Corresponding bit	0	1
1 byte mode	emibuf0	emibuf3

Corresponding bit	0			1		
2 byte mode	emibuf0	emibuf1		emibuf3	emibuf4	
3 byte mode	emibuf0	emibuf1	emibuf2	emibuf3	emibuf4	emibuf5

When EMIM = 0 and EMIEN = 1, EMI transfer start by writing to EMIBUF.

When EMIM = 1 and EMIEN = 1, EMI transfer will be started by SPI DMA.

PWM Operation Guide

1. Configure EMICON1 register;
2. Read data from FFT output buffer;
3. Write data to PWMDAT register.

13 Audio Terminal (DAC)

13.1 Features

CW6687B provides a high performance stereo 16-bit resolution audio DAC:

- Sample Rate 8 / 11.025 / 12 / 16 / 22.05 / 24 / 32 / 44.1 / 48KHz
- Low Clock Jitter Sensitivity
- Soft Mute and -48Db Attenuator
- Class AB headphone amplifier
- 32 Level analog Gain/attenuation from dB to dB

13.2 DAC Special Function Registers

There are 2 SFR to support DAC registers read/write function:

Register 13-1 ATADR - audio terminal address

Position	7	6	5	4	3	2	1	0
Name	DONE	DIR	ATADR					
Default	x	x	x	x	x	x	x	x
Access	RW	RW	RW	RW	RW	RW	RW	RW

DONE: read/write operation done flag

0 = read/write operation is done

1 =read/write operation is running

DIR: read/write direction select

0 =read register

1 = write register

ATADR: Address of DAC registers

Register 13-2 ATDAT - audio terminal data

Position	7	6	5	4	3	2	1	0
Name	ATDAT							
Default	x	x	x	x	x	x	x	x
Access	RW	RW	RW	RW	RW	RW	RW	RW

ATDAT:

After read operation, CPU reads this register to get the data.

Before write operation, CPU writes data to this register.

13.2.1 DAC Register Mapping

Table 13-1 DAC registers address mapping:

Name	Address	Descriptions
DACCFG	0	DAC configuration register
DACSM	1	DAC soft mute configuration register
DACSPR	2	DAC sample rate register
DACVOLL	3	DAC volume setting low byte register
DACVOLH	4	DAC volume setting high byte register
DACVCON	5	DAC volume control register
TRIMCON1	6	DAC trim control register1
TRIMCON2	7	DAC trim control register2
TRREGLL	8	DAC left channel trim data register low byte
TRREGLH	9	DAC left channel trim data register high byte
TRREGRL	10	DAC right channel trim data register low byte
TRREGRH	11	DAC right channel trim data register high byte
EQCON1	12	EQ configuration register1
EQCOF	13	EQ coefficient FIFO
EQCON2	14	EQ configuration register2
EQVOLIN	15	EQ data input volume configuration register
DACLRMIX0	16	DAC L & R channel mixing coefficient 0
DACLRMIX1	17	DAC L & R channel mixing coefficient 1
DACLRMIX2	18	DAC L & R channel mixing coefficient 2
DACLRMIX3	19	DAC L & R channel mixing coefficient 3

13.2.2 Function of DAC Control Registers

Register 13-3 DACCFG - DAC configuration register

Position	7	6	5	4	3	2	1	0
Name	-	-	-		DIT_SEL	MIX_EN	OSSL	DACEN
Default	-	-	-			0	0	0
Access	-	-	-			RW	RW	RW

DIT_SEL: sdm dither signal select

0 = sine wave

1 = white noise

MIX_EN: DAC MIX enable

0 = Disabled

1 = Enabled

OSSL: DAC over sample mode select

0 = Normal speed mode

1 = Double speed mode

DACEN: DAC digital filter/delta-sigma modulator enable

0 = Disabled

1 = Enabled

Register 13-4 DACSM - DAC soft mute configuration register

Position	7	6	5	4	3	2	1	0
Name	DACSM							
Default	0	1	1	1	1	1	1	0
Access	RW	RW	RW	RW	RW	RW	RW	RW

DAC soft mute configuration, the reset value of DACSM is 126, user should not change it.

Register 13-5 DACSPR - DAC sample rate register

Position	7	6	5	4	3	2	1	0
Name	-	-	-	-	SRSEL			
Default	-	-	-	-	0	0	0	1
Access	-	-	-	-	RW	RW	RW	RW

SRSEL: DAC/FM sample rate select

0000 = 48 KHz

0001 = 44.1 KHz

0010 = 32 KHz

0011 = Reserved

0100 = 24 KHz

0101 = 22.05 KHz

0110 = 16 KHz

0111 = Reserved

1000 = 12 KHz

1001 = 11.025 KHz

1010 = 8 KHz

1011 = Reserved

1100 = 48K synchronized with OBUF (+-0.8% max)

1101 = 44.1K synchronized with OBUF (+-0.8% max)

1110 = 32K synchronized with OBUF (+-0.8% max)

1111 = 16K synchronized with OBUF (+-0.8% max)

1011 = 8K synchronized with OBUF (+-0.8% max)

Register 13-6 DACVOLH - DAC volume setting high byte register

Position	7	6	5	4	3	2	1	0
Name	DACVPND	DACVOLH						
Default	1	0	0	0	0	1	1	1
Access	RW	RW	RW	RW	RW	RW	RW	RW

DACVPND: DAC volume adjust done pending

Read "0": not done

Read "1": done

Write "0" clear pending

Write "1" affects nothing

Register 13-7 DACVOLL– DAC volume setting low byte register

Position	7	6	5	4	3	2	1	0
Name	DACVOLL							
Default	1	1	1	1	1	1	1	1
Access	R/W	R/W	R/W	R/W	R/W	R/W	R/W	R/W

Note: When read DACVOLL and DACVOLH, the value isn't the setting value, but the actual DAC volume value

The DAC Volume multiple is : $DACVOL/(2^{11})$ where DACVOL is {DACVOLH,DACVOLL}

Example :

$$DACVOL = 0x07ff \text{ is } 0x07ff/(2^{11}) = 1 = 0 \text{ DB}$$

$$DACVOL = 0x7fff \text{ is } 0x7fff/(2^{11}) = 16 \approx +24 \text{ DB}$$

Register 13-8 DACVCON– DAC volume control register

Position	7	6	5	4	3	2	1	0
Name	-	-	-	DACVSET	DACVSTEP	DACVEN	DACVSTEP	
Default	-	-	-	0	0	0	0	0
Access	-	-	-	WO	R/W	R/W	R/W	R/W

DACVSET: Direct set DAC volume value

Write "1" to direct set DAC volume value

Write "0" affects nothing

DACVEN: DAC volume adjust enable

0 = Disable DAC volume adjust, keep the current volume

1 = Enable DAC volume adjust

{ **DACVSTEP2** , **DACVSTEP**}: DAC adjust volume steps

000 = Steps is "1"

001 = Steps is "2"

010 = Steps is "4"

011 = Steps is "8"

100 = Steps is "16"

101 = Steps is "32"

110 = Steps is "64"

111 = Steps is "128"

Register 13-9 TRIMCON1 - DAC trim control register1

Position	7	6	5	4	3	2	1	0
Name	TRIMSPEED		TRIMSTEP		DITSEL	TRIMSET	DONESEL	TRIMEN
Default	0	0	0	0	0	0	0	0
Access	RW	RW	RW	RW	RW	RW	RW	RW

TRIMSPEED: DAC trim speed control

00 = trim 1 step every 1 sample

01 = trim 1 step every 2 samples

10 = trim 1 step every 3 samples

11 = trim 1 step every 4 samples

TRIMSTEP: DAC trim step control

00 = Trim Step is 1

01 = Trim Step is 2

10 = Trim Step is 4

11 = Trim Step is 8

DITSEL: DAC trim direction select

0 = Trim direction depend on DAC analog compare out

1 = Trim direction depend on software direction

TRIMSET: DAC trim vale set direct

0 = reserve

1 = set direct

DONESEL: trimming done condition select

0 = Depend on DAC analog compare edge

1 = Depend on match data

TRIMEN: DAC trimming enable

0 = Disabled

1 = Enabled

Register 13-10 TRIMCON2 - DAC trim control register2

Position	7	6	5	4	3	2	1	0
Name	-	-	DIRETR	DIRETL	TRIMMTL	TRIMMTR	TMDONE	TRIMKST
Default	-	-	0	0	0	0	0	0
Access	-	-	RW	RW	RW	RW	RW	RW

DIRETR: DAC right trim direction

0 = Trim data decrease one step one sample

1 = Trim data add one step one sample

DIRETL: DAC left trim direction

0 = Trim data decrease one step one sample

1 = Trim data add one step one sample

TRIMMTL: DAC left channel trimming data match

0 = Not match

1 = Match

TRIMMTR: DAC right channel trimming data match

0 = Not match

1 = Match

TMDONE: DAC trimming done

0 = Not done

1 = Done

TRIMKST: DAC trimming kick start

Write 1 to kick start DAC trimming

Register 13-11 TRREGLL - DAC left channel trim data reg law byte

Position	7	6	5	4	3	2	1	0
Name	TRIMREGLL							
Default	-	-	-	-	-	-	-	-
Access	RW	RW	RW	RW	RW	RW	RW	RW

TRIMREGLL:

Write: DAC anticipant trimming data reg law byte

Read: DAC real trimming data law byte

Register 13-12 TRREGLH - DAC left channel trim data reg high byte

Position	7	6	5	4	3	2	1	0
Name	TRIMREGLH							
Default	-	-	-	-	-	-	-	-
Access	RW	RW	RW	RW	RW	RW	RW	RW

TRIMREGLL:

Write: DAC anticipant trimming data register high byte

Read: DAC real trimming data high byte

Register 13-13 TRREGRL- DAC right channel trim data reg law byte

Position	7	6	5	4	3	2	1	0
Name	TRIMREGRL							
Default	-	-	-	-	-	-	-	-
Access	RW	RW	RW	RW	RW	RW	RW	RW

TRIMREGRL:

Write: DAC anticipant trimming data register low byte

Read: DAC real trimming data low byte

Register 13-14 TRREGRH - DAC right channel trim data reg high byte

Position	7	6	5	4	3	2	1	0
Name	TRIMREGRH							
Default	-	-	-	-	-	-	-	-
Access	RW	RW	RW	RW	RW	RW	RW	RW

TRIMREGRH:

Write: DAC anticipant trimming data register high byte

Read: DAC real trimming data high byte

13.2.3 EQ and DRC Control Register

Register 13-15 EQCON1 - EQ configuration register1

Position	7	6	5	4	3	2	1	0
Name	DRCEN	EQEN	PEAKM	COMPONLY	STEREOSHARE	EQBANDCNT		
Default	0	0	0	0	0	0	0	0
Access	R/W	R/W	R/W	R/W	R/W	R/W	R/W	R/W

DRCEN: DRC enable bit

0 = disable

1 = enable

EQEN: EQ enable bit

0 = Disabled

1 = Enabled

PEAKM: DRC peak level detector mode select

0 = mode 0 (preferred)

1 = mode 1

COMPONLY : DRC Compressor

0 = DRC include Limiter, Compressor, Expander and Noise gate

1 =DRC just Limiter, Compressor only (preferred)

STEREOSHARE: stereo share one DRC select bits

0 = left right channel has respective DRC

1 =left right channel share joint DRC

EQBANDCNT: EQ BAND counters

Configuration the number of EQ BAND

Register 13-16 EQCON2 - EQ configuration register2

Position	7	6	5	4	3	2	1	0
Name	DONE					CFGADRCLR	BUFINIT	EQ_RST
Default	0					0	0	0
Access	R/W					WO	WO	WO

EQ_RST: EQ RST

0 = reset EQ

1 = release EQ rst

BUFINIT: EQ buffer clear

Write 1 kick start buffer initial

Write 0 is invalidation

CFGADRCLR: EQ cof address clear

Write 1 reset EQ cof address

Write 0 is invalidation

DONE: EQ buffer initial done flag

1 = Done

0 = Not done

Register 13-17 EQCOF - EQ coefficient FIFO

Position	7	6	5	4	3	2	1	0
Name	EQCOF							
Default	x	x	x	x	x	x	x	x
Access	WO	WO	WO	WO	WO	WO	WO	WO

EQCOF:

As the coefficient is 24 bits, so write EQCOF three times low byte first (= EQCOF*(2²²-1))

DRC coefficient is 24bits, write EQCOF three times low byte first(= DRCCOF*(2¹⁸-1) reference DRC C model)

The order of coefficient as follow:

EQ coefficient:

EQ BAND0	Gain COF	24 bits
	EQ BAND 0 COF0 or IIR BAND 0 COF0	
	EQ BAND 0 COF2 or IIR BAND 0 COF2	
	EQ BAND 0 COF1 or IIR BAND 0 COF1	
	EQ BAND 0 negative COF4 or IIR BAND 0 negative COF4	
	EQ BAND 0 negative COF5 or IIR BAND 0 negative COF5	
EQ BAND1	EQ BAND 1 COF0 or IIR BAND 1 COF0	24 bits
	EQ BAND 1 COF2 or IIR BAND 1 COF2	
	EQ BAND 1 COF1 or IIR BAND 1 COF1	
	EQ BAND 1 negative COF4 or IIR BAND 1 negative COF4	
	EQ BAND 1 negative COF5 or IIR BAND 1 negative COF5	
EQ BANDn	24 bits
Reservation	0x000000	24 bits
DRC at_comexp	DRC attack time coefficient for compressor	24 bits
DRC rt_comexp	DRC release time coefficient for compressor	24 bits
DRC at_lim	DRC attack time coefficient for limiter	24 bits
DRC rt_lim	DRC release time coefficient for limiter	24 bits
DRC LT	DRC Limiter Thresholds DB (Limiter exceed LT)	24 bits
DRC LS	DRC Limiter slope	24 bits
DRC CT	DRC Compressor Thresholds DB (Compressor rang LT to CT)	24 bits
DRC CS	DRC Compressor slope	24 bits
DRC ET	DRC Expander Thresholds DB (Expander range ET to NT)	24 bits
DRC ES	DRC Expander slope	24 bits
DRC NT	DRC Noise Gate Thresholds DB (Attenuate below NT)	24 bits
DRC NS	DRC Noise Gate slope	24 bits
DRC GAIN	DRC gain offset	24 bits

DRC TAV	The averaging coefficient	24 bits
---------	---------------------------	---------

Register 13-18 EQVOLIN - EQ data input volume configuration register

Position	7	6	5	4	3	2	1	0
Name	EQVOLIN							
Default	x	x	x	x	x	x	x	x
Access	W/R	W/R	W/R	W/R	W/R	W/R	W/R	W/R

The input volume of EQ data rang from 0x0000 to 0x7fff, write twice high byte first.

0x7fff represent 0 db

0x000 represent silence

Register 13-19 DACLRMIX0: DAC L & R channel mixing coefficient register0

Position	7	6	5	4	3	2	1	0
Name	DACLRMIX0							
Default	0	1	1	1	1	1	1	1
Access	RW	RW	RW	RW	RW	RW	RW	RW

DAC L & R channel mixing coefficient 0

NOTE: DACLRMIX0 and DACLRMIX1 are used to control how L channel is combined with R channel to generate the final L channel output. The content of DACLRMIX0 and DACLRMIX1 each represents a 8 bit signed number which ranges from -128 ~ 127. the L channel output is calculated from the following equation:

$$L_{out} = L_{in} * DACLRMIX0/128 + R_{in} * DACLRMIX1/128$$

Register 13-20 DACLRMIX1 DAC L & R channel mixing coefficient register1

Position	7	6	5	4	3	2	1	0
Name	DACLRMIX1							
Default								
Access	RW	RW	RW	RW	RW	RW	RW	RW

DAC L & R channel mixing coefficient 1 register

NOTE: DACLRMIX0 and DACLRMIX1 are used to control how L channel is combined with R channel to generate the final L channel output. The content of DACLRMIX0 and DACLRMIX1 each represents a 8 bit signed number which ranges from -128 ~ 127. the L channel output is calculated from the following equation:

$$L_{out} = L_{in} * DACLRMIX0/128 + R_{in} * DACLRMIX1/128$$

Register 13-21 DACLRMIX2 DAC L & R channel mixing coefficient register2

Position	7	6	5	4	3	2	1	0
Name	DACLRMIX2							
Default	0	0	0	0	0	0	0	0
Access	RW	RW	RW	RW	RW	RW	RW	RW

DAC L & R channel mixing coefficient register 2

NOTE: DACLRMIX2 and DACLRMIX3 are used to control how R channel is combined with L channel to generate the final R channel output. The content of DACLRMIX2 and DACLRMIX3 each represents a 8 bit signed number which ranges from -128 ~ 127. the R channel output is calculated from the following equation:

$$R_{out} = L_{in} * DACLRMIX2/128 + R_{in} * DACLRMIX3/128$$

Register 13-22 DACLRMIX3 DAC L & R channel mixing coefficient 3

Position	7	6	5	4	3	2	1	0
Name	DACLRMIX3							
Default	0	1	1	1	1	1	1	1
Access	RW	RW	RW	RW	RW	RW	RW	RW

DAC L & R channel mixing coefficient register 3

NOTE: DACLRMIX2 and DACLRMIX3 are used to control how R channel is combined with L channel to generate the final R channel output. The content of DACLRMIX2 and DACLRMIX3 each represents a 8 bit signed number which ranges from -128 ~ 127. the R channel output is calculated from the following equation:

$$R_{out} = L_{in} * DACLRMIX2/128 + R_{in} * DACLRMIX3/128$$

Register 17-28 KVCCON– Key Voice control

Position	7	6	5	4	3	2	1	0
Name	-	-	-	-	-	-	MPEN	KEYEN
Default	x	x	x	x	x	x	1	0
Access	x	x	x	x	x	x	R/W	R/W

KEY_DMA_ADRH: Key voice DMA high address

MPEN: MP3 is playing enable

0 = Disable MP3 play when plays key voice

1 = Enable MP3 play when plays key voice

KEYEN: Key Voice enable

0 = Disabled

1 = Enabled

Register 17-29 KVCCON2– Key Voice control

Position	7	6	5	4	3	2	1	0
Name	KVCCYC[4:0]					KVV[2:0]		
Default	0	0	0	0	1	1	1	1
Access	R/W	R/W	R/W	R/W	R/W	R/W	R/W	R/W

KVCCON2: key voice control

KVV [2:0]: key voice volume control

000 = volume div 128

001 = volume div 64

010 = volume div 32

011 = volume div 16

100 = volume div 8

101 = volume div 4

110 = volume div 2

111 = 0db

KVCCYC [4:0]: key voice plays cycle control

The real cycle of key voice play is KVCCYC [4:0] * 8.

Register 17-30 KVCADR– Key Voice DMA address

Position	7	6	5	4	3	2	1	0
Name	KEY_DMA_ADR							
Default	x	x	x	x	x	x	x	x
Access	WO	WO	WO	WO	WO	WO	WO	WO

When configure key voice DMA address, should write this register three times. First configure the DMA start high address, second configure the DMA start low address, and third configure the DMA end low address. It can only change between 0 to 0xff

13.3 Operation Guide

13.3.1 DAC Operation Guide

1. Configure DACVOLL & DACVOLH
2. Configure DACVCON
3. Clear DACVPND to kick start adjust volume

13.3.2 EQ Operation Guide

1. Configure EQCON2 to release The rest of EQ
2. Configure EQCON1 BIT 6 to kick initiate the buffer ram and wait done
3. Configure EQVOLIN
4. Configure EQCOF to initiate coefficient
5. Configure EQCON1 to enable EQ

Notice:

- 1) If user wants to change the coefficient of EQ he/she must configure EQCON1 disable EQ, then repeat upwards operation guide flow.

14 SARADC

14.1 Features

CW6687B provides an 11-channel moderate conversion speed and a moderate resolution 10-bit successive approximated register Analog to Digital Converter (SARADC) for users to develop applications in the following areas:

- Voice grade applications
- Audio applications requiring moderate performance
- Measurement requiring moderate performance and speed

SARADC conversion clock must be slower than 1 MHz

14.2 ADC Pin Mapping

Table 14-1 pin used

ADC Channel	Function	Description
ADC10	TP3	
ADC9	TP2	
ADC8	P26	Only for PIN detected, Not for ADKEY
ADC7	LDO Band GAP	Reference voltage 0.864V
ADC6	LDO in	1/2 Battery voltage
ADC5	P13	Normal ADC channel
ADC4	P30	Normal ADC channel
ADC3	P22	Normal ADC channel
ADC2	P14	Normal ADC channel
ADC1	P21	Normal ADC channel
ADC0	P33	Normal ADC channel

14.3 SARADC Special Function Registers

Register 14-1 ADCCON– SARADC control

Position	7	6	5	4	3	2	1	0
Name	ADCGO	EOC	TMREN	ADCTL	ADCEN	ADCSEL		
Default	0	0	x	x	0	0	0	0
Access	R/W	RO	R/W	R/W	R/W	R/W	R/W	R/W

ADCGO: ADC Conversion Start

When read:

0 = Conversion finished

1 = Conversion not finished

When write:

0 = N/A

1 = Start conversion

EOC: Check if end of conversion

0 = Finished

1 = Not finished

TMREN: Timer Input Enable

0 = Disabled

1 = Enabled

ADCTL: Timer Source Select

0 = Timer0

1 = Timer1

ADCEN: ADC Module Enable

0 = Disabled

1 = Enabled

ADCS3, ADCSEL: ADC Channel Select

0000 = P3.3 (ADC0)

0001 = P2.1 (ADC1)

0010 = P1.4 (ADC2)

0011 = P2.2 (ADC3)

0100 = P3.0 (ADC4)

0101 = P1.3 (ADC5)

0110 = 1/2 Battery voltage

0111 = LDO_BG. 0.864V

1000 = P26 (ADC8, Only for PIN detected, Not for ADKEY)

1001 = TP2

1010 = TP3

Register 14-2 ADCMODE– SARADC mode control

Position	7	6	5	4	3	2	1	0
Name	-	-	-	ADCS3	AUTOS	ADCSEL_SH		
Default	0	0	0	0	0	0	0	0
Access	RO	RO	RO	R/W	R/W	R/W	R/W	R/W

ADCS3: ADC Channel Select 3

ADCSEL_SH: ADCSEL shadow

AUTOS: Auto channel switching mode

0 = Not switch

1 = Auto load ADCSEL_SH into ADCSEL after conversion finished

Register 14-3 ADCBAUD– SARADC baud rate control

Position	7	6	5	4	3	2	1	0
Name	-	-	ADCBAUD					
Default	-	-	x	x	x	x	x	x
Access	-	-	WO	WO	WO	WO	WO	WO

ADC conversion clock = system clock / (2 x (ADCBAUD + 1))

Register 14-4 ADCDATAL– SARADC Buffer low byte control

Position	7	6	5	4	3	2	1	0
Name	ADCDATAL		-	-	-	-	-	-
Default	x	x	-	-	-	-	-	-
Access	RO	RO	-	-	-	-	-	-

Register 14-5 ADCDATAH– SARADC Buffer high byte control

Position	7	6	5	4	3	2	1	0
Name	ADCDATAH							
Default	x	x	x	x	x	x	x	x
Access	RO	RO	RO	RO	RO	RO	RO	RO

15 CRC16 /LFSR16/LFSR32

15.1 CRC16

15.1.1 Features

Cyclic Redundancy Check (CRC) is an error-checking code that is widely used in data communication systems and other serial data transmission system. CRC is based on polynomial manipulation using modular arithmetic. The device supports CRC by a CRC circuit module. The CRC FIFO supports CRC-CCITT.

The CRC-CCITT polynomial is defined as:

$$\text{CRC}(x) = X^{16} + X^{12} + X^5 + 1$$

Figure 15-1 shows CRC FIFO block diagram.

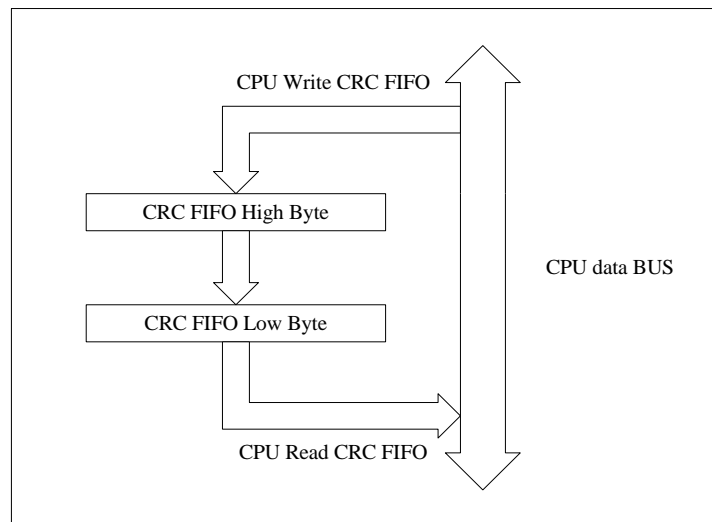

Figure 15-1 CRC FIFO block diagram

Write CRCREG to initial CRC register. Write data into CRCFIFO after initialization, and data will be shifted into module from low bit to high bit. Get the results by reading CRCRES0 and CRCRES1.

15.1.2 CRC16 Special Function Registers

Register 15-1 CRCREG– CRC initial register

Position	7	6	5	4	3	2	1	0
Name	CRCREG							
Default	1	1	1	1	1	1	1	1
Access	WO	WO	WO	WO	WO	WO	WO	WO

Write this location will initial CRC register.

Note: To initialize the CRC register, user needs to write 2 bytes to CRCREG for CRC16 (High byte first).

Register 15-2 CRCFIFO– CRC FIFO control

Position	7	6	5	4	3	2	1	0
Name	CRCFIFO							
Default	x	x	x	x	x	x	x	x
Access	WO	WO	WO	WO	WO	WO	WO	WO

Write this location will load the data to CRC module;

Register 15-3 CRCRES0– CRC result 0 control

Position	7	6	5	4	3	2	1	0
Name	CRCRES0							
Default	x	x	x	x	x	x	x	x
Access	RO	RO	RO	RO	RO	RO	RO	RO

Register 15-4CRCRES1– CRC result 1 control

Position	7	6	5	4	3	2	1	0
Name	CRCRES1							
Default	x	x	x	x	x	x	x	x
Access	RO	RO	RO	RO	RO	RO	RO	RO

15.2 LFSR16

15.2.1 Features

Software can control lfsr16, or enable CRCEN of SPI1CON1 [1], hardware can auto trigger lfsr16 when spi1 receive data.

The LFSR16 polynomial is defined as:

$$LFSR16(x) = X^{16} + X^{15} + X^{14} + X^{12} + X^8 + X + 1$$

15.2.2 LFSR16 Special Function Register

Register 15-5 LFSR16_DAT0– LFSR16 data 0

Position	7	6	5	4	3	2	1	0
Name	LFSR16_DAT0							
Default	1	1	1	1	1	1	1	1
Access	W/R	W/R	W/R	W/R	W/R	W/R	W/R	W/R

Note: To initiate the LFSR16 register, user needs to write this register 2 times to LFSR16 register for LFSR16 (High byte first). Reading will output LFSR16 data0

Register 15-6 LFSR16_DAT1– LFSR16 data 1

Position	7	6	5	4	3	2	1	0
Name	LFSR16_DAT1							

Default	1	1	1	1	1	1	1	1
Access	W/R	W/R	W/R	W/R	W/R	W/R	W/R	W/R

Note: Writing this register will trigger a calculation once from lfsr16; Reading will output LFSR16 data 1

15.3 LFSR32

15.3.1 Features

The LFSR32 polynomial is defined as:

$$\text{LFSR32}(x) = X^{32} + X^{26} + X^2 + 1.$$

15.3.2 LFSR32 Special Function Registers

Register 15-7 LFSR32_DAT0– LFSR32 data 0

Position	7	6	5	4	3	2	1	0
Name	LFSR32_DAT0							
Default	1	1	1	1	1	1	1	1
Access	W/R	W/R	W/R	W/R	W/R	W/R	W/R	W/R

Note: To initiate the LFSR32 register, user needs to write this register 4 times to LFSR32 register for LFSR32 (High byte first). Reading will output LFSR32 data0

Register 15-8 LFSR32_DAT1– LFSR32 data 1

Position	7	6	5	4	3	2	1	0
Name	LFSR32_DAT1							
Default	1	1	1	1	1	1	1	1
Access	W/R	W/R	W/R	W/R	W/R	W/R	W/R	W/R

Note: Write this register, will trigger lfsr32 calculate one time; Reading will output LFSR32 data 1

Register 15-9 LFSR32_DAT2– LFSR32 data 2

Position	7	6	5	4	3	2	1	0
Name	LFSR32_DAT2							
Default	1	1	1	1	1	1	1	1
Access	RO	RO	RO	RO	RO	RO	RO	RO

Note: Reading will output LFSR32 data 2

Register 15-10 LFSR32_DAT3– LFSR32 data 3

Position	7	6	5	4	3	2	1	0
Name	LFSR32_DAT3							
Default	1	1	1	1	1	1	1	1
Access	RO	RO	RO	RO	RO	RO	RO	RO

Note: Reading will output LFSR32 data 3

16 Characteristics

16.1 PMU Parameters

Table 16-1 PMU Parameters

Sym	Characteristics	Min	Typ	Max	Unit	Conditions
VIN	LDO/buck input voltage	2.2	4.2	4.8	V	
VOUT1v5	Buck output voltage	-	1.5	-	V	
DVDD	1.2V output voltage	-	1.2	-	V	
RVDD	1.2V output voltage	-	1.2	-	V	
VDD33	3.3V output voltage	-	3.3	-	V	

16.2 CORE PLL Parameters

Table 16-2 PLL Parameters

Sym	Characteristics	Min	Typ	Max	Unit	Conditions
FI1	Frequency input	-	32.768	-	KHz	Low frequency OSC
FI2	Frequency input	1	12	15	MHz	High frequency OSC
FOUT1	Frequency output	-	48	-	MHz	
TLOCK1	PLL locked time	-	2	-	ms	Use low frequency OSC as input reference
TLOCK2	PLL locked time	-	0.1	-	ms	Use high frequency OSC as input reference

16.3 General purpose I/O Parameters

Table 16-3 I/O Parameters

Symbol	Description	Min	Typ	Max	Units	Conditions
V _{IL}	Low-Level input voltage	-	-	30% * VDDIO	V	VDDIO = 3.3V
V _{IH}	High-level input voltage	70% * VDDIO	-	-	V	VDDIO = 3.3V
R _{PUP0}	Internal pull-up resistor 0	2.64	3.3	3.96	KΩ	For PORT2
R _{PDN0}	Internal pull-down resistor 0	2.64	3.3	3.96	KΩ	For PORT2
R _{PUP1}	Internal pull-up resistor 1	8	10	12-	KΩ	For PORT0/1/3
R _{PDN1}	Internal pull-down resistor 1	8	10	12	KΩ	For PORT0/1/3
I _{LEVEL1}	Level1 current driving	8	-	-	mA	For PORT1
I _{LEVEL2}	Level2 current driving	24	-	-	mA	For Port1.1

16.4 Audio ADDA Parameters

Table 16-4 Audio DAC Parameters

Sym	Characteristics	Min	Typ	Max	Unit	Conditions
DAC SNR&DR		-	92	-	dB	48PIN
DAC SNR&DR		-	82	-	dB	28PIN & 20 PIN
DAC THD+N		-	-70	-	dB	10Kohm loading
PWR _{AB}	ClassAB AMP power output	-	-	16	mW	32ohm loading
V _{PP}	Maximum output voltage	-	-	2.8	V	10Kohm loading
ADC SNR/DR		-	90	-	dB	
ADC THD+N		-	-	-	dB	

16.5 RF Analog Blocks

Table 16-7 Frequency Synthesizer Parameters

Parameter	CONDITION	MIN	typ	max	Unit	
Synthesizer						
Synthesizer settling time	Within +/- 25 KHz accuracy	-	70	-	us	
Phase Noise	Fc=2.4GHz	$\Delta F=1$ MHz	-	-115	-	dBc/Hz
		$\Delta F=2$ MHz	-	-120	-	dBc/Hz
		$\Delta F \geq 3$ MHz	-	-130	-	dBc/Hz
XTAL Oscillator						
Frequency range		-	26	-	MHz	
Frequency Trimming Range	6 bits	-2	-	+2	kHz	

Table 16-8 Receive path Parameters

Parameter	CONDITION	MIN	typ	max	Unit
Receiver Channel					
Minimum Usable Signal	RX sensitivity	-	-85	-	dBm
LNA					
Gain	High Gain	-	25	-	dB
	Mid Gain	-	8	-	dB
	Low Gain	-	-10	-	dB
RFamp					
Gain		-	8.7	-	dB
Mixer					

Parameter	CONDITION	MIN	typ	max	Unit
Conversion Gain		-	-2.4	-	dB
IFamp					
Gain	22/19/16/13 dB	-	16	-	
Complex BPF					
Band pass -3 dB BW	Figure 1.	-	2	-	MHz
Image Rejection		-	30	-	dB
VGA					
Gain Range		-6	-	+48	dB
Gain Step		-	+1/+6	-	dB
ADMOD					
SNDR	Freq = +- BW	-	>50	-	dB

Table 16-9 Transmit path Parameters

Parameter	CONDITION	MIN	typ	max	Unit	
Transmit Channel						
Available output power		-2	0	1.5	dBm	
Side Band Suppression		-	-30	-	dBm	
LPF						
Low pass -3 dB BW		-	2	-	MHz	
TXVGA						
Gain Step		0.5	-	5	dB	
PA						
Gain Range	Set paPWR[2:0] of Control Register #16	GFSK	-12	-	5	dBm
		DPSK	-15	-	2	dBm

Note: For each analog RF block register setting, please refer to "BT_EDR_Register_v11I_BT8201AS.xls"

17 Package Outline Dimensions

17.1 QFN32

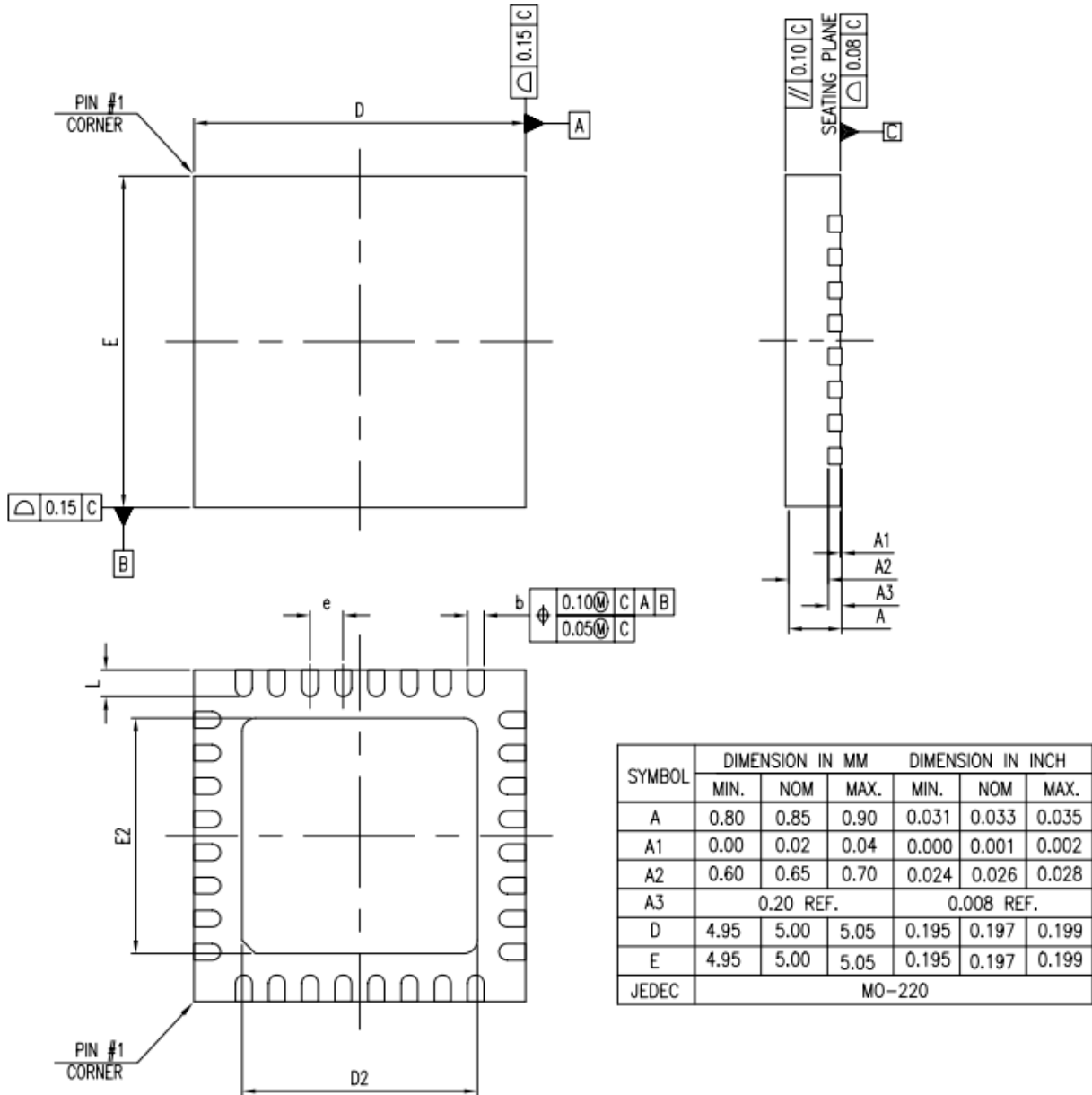

N	b			D2			E2			e	L		
	MIN.	NOM.	MAX.	MIN.	NOM.	MAX.	MIN.	NOM.	MAX.		MIN.	NOM.	MAX.
16L	0.25	0.30	0.35	3.20	3.25	3.30	3.20	3.25	3.30	0.800 BSC	0.50	0.55	0.60
28L	0.20	0.25	0.30	3.45	3.50	3.55	3.45	3.50	3.55	0.500 BSC	0.40	0.45	0.50
32L-1	0.20	0.25	0.30	3.50	3.55	3.60	3.50	3.55	3.60	0.500 BSC	0.35	0.40	0.45
32L-2	0.20	0.25	0.30	3.74	3.79	3.84	3.74	3.79	3.84	0.500 BSC	0.25	0.30	0.35
32L-3	0.20	0.25	0.30	3.10	3.15	3.20	3.10	3.15	3.20	0.500 BSC	0.35	0.40	0.45
40L-1	0.15	0.20	0.25	3.55	3.60	3.65	3.55	3.60	3.65	0.400 BSC	0.35	0.40	0.45
40L-2	0.15	0.20	0.25	3.74	3.79	3.84	3.74	3.79	3.84	0.400 BSC	0.25	0.30	0.35

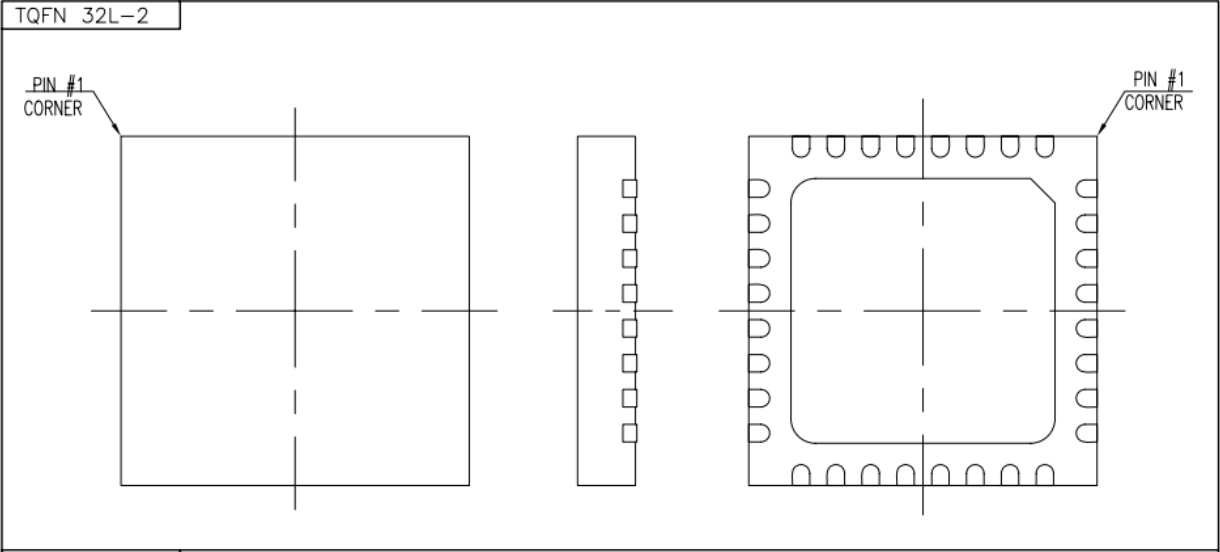

Figure 17-1 QFN32 Package Outline Dimension

Revision History

Date	Version	Comments	Revised by
2015-10-23	0.0.1	Initial verison	YX
2015-10-23	0.0.2	Modify Feature, delete IIC/IIS/SD.....	CJ
2015-10-26	0.0.3	Modify and check	GAO
2015-10-26	1.0.0	Release	YX

FCC Warning Statement

This equipment has been tested and found to comply with the limits for a Class B digital device, pursuant to part 15 of the FCC Rules. These limits are designed to provide reasonable protection against harmful interference in a residential installation. This equipment generates, uses and can radiate radio frequency energy and, if not installed and used in accordance with the instructions, may cause harmful interference to radio communications. However, there is no guarantee that interference will not occur in a particular installation. If this equipment does cause harmful interference to radio or television reception, which can be determined by turning the equipment off and on, the user is encouraged to try to correct the interference by one or more of the following measures:

- Reorient or relocate the receiving antenna.
- Increase the separation between the equipment and receiver.
- Connect the equipment into an outlet on a circuit different from that to which the receiver is connected.
- Consult the dealer or an experienced radio/TV technician for help.

Caution: Any changes or modifications to this device not explicitly approved by manufacturer could void your authority to operate this equipment.

This device complies with part 15 of the FCC Rules. Operation is subject to the following two conditions: (1) This device may not cause harmful interference, and (2) this device must accept any interference received, including interference that may cause undesired operation.

The device has been evaluated to meet general RF exposure requirement. The device can be used in portable exposure condition without restriction.