



# FCC Part 15C Test Report

## FCC ID: 2AFGKSM3740

|                  |   |
|------------------|---|
| Product Name:    | Waterproof Bluetooth speaker with sucker                              |
| Trademark:       | N/A   |
| Model Name :     | SM3740  |
| Serial Model :   | M9  |
| Prepared For :   | Simlok Electronic manufactory co.,ltd                                 |
| Address :        | RM123, BLD 19, PACKING AREA, CHINA SOUTH CITY, PINGHU, SHENZHEN,CHINA |
| Prepared By :    | Shenzhen BCTC Technology Co., Ltd.                                    |
| Address :        | No.101,Yousong Road,Longhua New District, Shenzhen,China              |
| Test Date:       | Oct. 08, - Oct. 15, 2016  |
| Date of Report : | Oct. 15, 2016   |
| Report No.:      | BCTC-FY160904067E   |



### CERTIFICATION

**Applicant's name** ..... : Simlok Electronic manufactory co.,ltd  
**Address** ..... : RM123, BLD 19, PACKING AREA, CHINA SOUTH CITY, PINGHU, SHENZHEN,CHINA  
**Manufacture's Name**..... : Simlok Electronic manufactory co.,ltd  
**Address** ..... : RM123, BLD 19, PACKING AREA, CHINA SOUTH CITY, PINGHU, SHENZHEN,CHINA

#### Product description

**Product name** ..... : Waterproof Bluetooth speaker with sucker  
**Trademark** ..... : N/A  
**Model and/or type reference** : SM3740  
M9

**Standards** ..... : FCC Part15.249  
ANSI C63.10-2013

This device described above has been tested by BCTC, and the test results show that the equipment under test (EUT) is in compliance with the FCC requirements. And it is applicable only to the tested sample identified in the report.

This report shall not be reproduced except in full, without the written approval of BCTC, this document may be altered or revised by BCTC, personal only, and shall be noted in the revision of the document.

Testing Engineer : Eric Yang  
Eric Yang

Reviewer (Supervisor) : Jade Yang  
Jade Yang

Approved & Authorized Signer(Manager) : Carson Zhang  

**Table of Contents**

|   | <b>Page</b> |
|---|-------------|
| <b>1 . SUMMARY OF TEST RESULTS</b>                          | <b>5</b>    |
| 1.1 TEST FACILITY   | 5           |
| 1.2 MEASUREMENT UNCERTAINTY                                 | 5           |
| <b>2 . GENERAL INFORMATION</b>                              | <b>6</b>    |
| 2.1 GENERAL DESCRIPTION OF EUT                              | 6           |
| 2.2 DESCRIPTION OF TEST MODES                               | 7           |
| 2.3 BLOCK DIGRAM SHOWING THE CONFIGURATION OF SYSTEM TESTED | 8           |
| 2.4 DESCRIPTION OF SUPPORT UNITS(CONDUCTED MODE)            | 8           |
| 2.5 EQUIPMENTS LIST FOR ALL TEST ITEMS                      | 9           |
| <b>3 . EMC EMISSION TEST</b>                                | <b>10</b>   |
| 3.1 CONDUCTED EMISSION MEASUREMENT                          | 10          |
| 3.1.1 POWER LINE CONDUCTED EMISSION LIMITS                  | 10          |
| 3.1.2 TEST PROCEDURE  | 10          |
| 3.1.3 DEVIATION FROM TEST STANDARD                          | 10          |
| 3.1.4 TEST SETUP  | 11          |
| 3.1.5 EUT OPERATING CONDITIONS                              | 11          |
| 3.1.6 TEST RESULTS  | 11          |
| 3.2 RADIATED EMISSION MEASUREMENT                           | 14          |
| 3.2.1 RADIATED EMISSION LIMITS                              | 14          |
| 3.2.2 TEST PROCEDURE  | 15          |
| 3.2.3 DEVIATION FROM TEST STANDARD                          | 15          |
| 3.2.4 TEST SETUP  | 15          |
| 3.2.5 EUT OPERATING CONDITIONS                              | 16          |
| 3.2.6 TEST RESULTS (BETWEEN 9KHZ – 30 MHZ)                  | 17          |
| 3.2.7 TEST RESULTS (BETWEEN 30MHZ – 1GHZ)                   | 18          |
| 3.2.8 TEST RESULTS (1GHZ~25GHZ)                             | 20          |
| 3.3 RADIATED BAND EMISSION MEASUREMENT                      | 23          |
| 3.3.1 TEST REQUIREMENT:                                     | 23          |
| 3.3.2 TEST PROCEDURE  | 23          |
| 3.3.3 DEVIATION FROM TEST STANDARD                          | 24          |
| 3.3.4 TEST SETUP  | 24          |
| 3.3.5 EUT OPERATING CONDITIONS                              | 24          |
| <b>4 . BANDWIDTH TEST</b>                                   | <b>28</b>   |
| 4.1 APPLIED PROCEDURES / LIMIT                              | 28          |
| 4.1.1 TEST PROCEDURE  | 28          |



| <b>Table of Contents</b>       |             |
|--------------------------------|-------------|
|                                | <b>Page</b> |
| 4.1.2 DEVIATION FROM STANDARD  | 28          |
| 4.1.3 TEST SETUP               | 28          |
| 4.1.4 EUT OPERATION CONDITIONS | 28          |
| 4.1.5 TEST RESULTS             | 29          |
| <b>5 . ANTENNA REQUIREMENT</b> | <b>34</b>   |
| 5.1 STANDARD REQUIREMENT       | 34          |
| 5.2 EUT ANTENNA                | 34          |
| <b>6 . TEST SEUUP PHOTO</b>    | <b>35</b>   |
| <b>7 . EUT PHOTO</b>           | <b>37</b>   |



## 1. SUMMARY OF TEST RESULTS

Test procedures according to the technical standards:

| FCC Part15 (15.249) , Subpart C |                            |          |        |
|---------------------------------|----------------------------|----------|--------|
| Standard Section                | Test Item                  | Judgment | Remark |
| 15.207                          | Conducted Emission         | PASS     |        |
| 15.249                          | Radiated Spurious Emission | PASS     |        |
| 15.249                          | Bandwidth                  | PASS     |        |
| 15.205                          | Band Edge Emission         | PASS     |        |
| 15.203                          | Antenna Requirement        | PASS     |        |

### NOTE:

(1) "N/A" denotes test is not applicable in this Test Report

### 1.1 TEST FACILITY

Shenzhen BCTC Technology Co., Ltd.

Add. : No.101,Yousong Road,Longhua New District, Shenzhen,China

FCC Registered No.: 187086

### 1.2 MEASUREMENT UNCERTAINTY

The reported uncertainty of measurement  $y \pm U$ , where expanded uncertainty  $U$  is based on a standard uncertainty multiplied by a coverage factor of  $k=2$ , providing a level of confidence of approximately 95 %.

| No. | Item                         | Uncertainty             |
|-----|------------------------------|-------------------------|
| 1   | Conducted Emission Test      | $\pm 1.38\text{dB}$     |
| 2   | RF power,conducted           | $\pm 0.16\text{dB}$     |
| 3   | Spurious emissions,conducted | $\pm 0.21\text{dB}$     |
| 4   | All emissions,radiated(<1G)  | $\pm 4.68\text{dB}$     |
| 5   | All emissions,radiated(>1G)  | $\pm 4.89\text{dB}$     |
| 6   | Temperature                  | $\pm 0.5^\circ\text{C}$ |
| 7   | Humidity                     | $\pm 2\%$               |



## 2. GENERAL INFORMATION

### 2.1 GENERAL DESCRIPTION OF EUT

|                        |  |                      |
|------------------------|--|----------------------|
| Equipment              | Waterproof Bluetooth speaker with sucker   |                      |
| Trademark              | N/A  |                      |
| Model Name             | SM3740   |                      |
| Serial Model           | M9   |                      |
| Model Difference       | All the same, Only model name is different.  |                      |
| Product Description    | The EUT is a Waterproof Bluetooth speaker with sucker  |                      |
|                        | Operation Frequency:   | 2402~2480 MHz        |
|                        | Modulation Type:   | GFSK,PI/4 DPSK,8DPSK |
|                        | Bit Rate of Transmitter  | 1/2/3Mbps            |
|                        | Number Of Channel  | 79 CH                |
|                        | Antenna type:  | Internal Antenna     |
|                        | Antenna Gain (dBi)   | 0dBi                 |
|                        | Based on the application, features, or specification exhibited in User's Manual, the EUT is considered as an ITE/Computing Device. More details of EUT technical specification, please refer to the User's Manual. |                      |
| Channel List           | Please refer to the Note 2.  |                      |
| Power                  | DC 3.7V<br>DC 5V from USB  |                      |
| hardware version       | --   |                      |
| Software version       | --   |                      |
| Serial number          | --   |                      |
| Connecting I/O Port(s) | Please refer to the User's Manual  |                      |

Note:

1. For a more detailed features description, please refer to the manufacturer's specifications or the User's Manual.



2.

| Channel List |                 |         |                 |         |                 |
|--------------|-----------------|---------|-----------------|---------|-----------------|
| Channel      | Frequency (MHz) | Channel | Frequency (MHz) | Channel | Frequency (MHz) |
| 00           | 2402            | 27      | 2429            | 54      | 2456            |
| 01           | 2403            | 28      | 2430            | 55      | 2457            |
| 02           | 2404            | 29      | 2431            | 56      | 2458            |
| ~            | ~               | ~       | ~               | ~       | ~               |
| 08           | 2410            | 35      | 2437            | 62      | 2464            |
| 09           | 2411            | 36      | 2438            | 63      | 2465            |
| 10           | 2412            | 37      | 2439            | 64      | 2466            |
| 11           | 2413            | 38      | 2440            | 65      | 2467            |
| 12           | 2414            | 39      | 2441            | 66      | 2468            |
| 13           | 2415            | 40      | 2442            | 67      | 2469            |
| ~            | ~               | ~       | ~               | ~       | ~               |
| 14           | 2416            | 41      | 2443            | 68      | 2470            |
| 22           | 2424            | 49      | 2451            | 76      | 2478            |
| 23           | 2425            | 50      | 2452            | 77      | 2479            |
| 24           | 2426            | 51      | 2453            | 78      | 2480            |
| 25           | 2427            | 52      | 2454            |         |                 |
| 26           | 2428            | 53      | 2455            |         |                 |

## 2.2 DESCRIPTION OF TEST MODES

To investigate the maximum EMI emission characteristics generated from EUT, the test system was pre-scanning tested based on the consideration of following EUT operation mode or test configuration mode which possibly have effect on EMI emission level. Each of these EUT operation mode(s) or test configuration mode(s) mentioned above was evaluated respectively.

| Test Mode | Description |                         |
|-----------|-------------|-------------------------|
| Mode 1    | CH00        | GFSK,PI/4<br>DPSK,8DPSK |
| Mode 2    | CH39        |                         |
| Mode 3    | CH78        |                         |
| Mode 4    | Link Mode   |                         |

Note:

(1) The measurements are performed at the highest, middle, lowest available channels.

### 2.3 BLOCK DIGRAM SHOWING THE CONFIGURATION OF SYSTEM TESTED

Radiated Spurious Emission Test

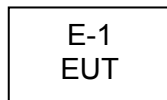

Conducted Spurious Emission Test

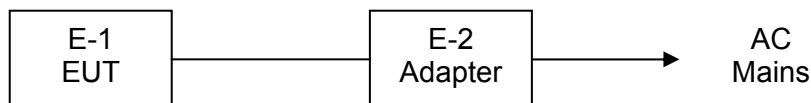

### 2.4 DESCRIPTION OF SUPPORT UNITS(CONDUCTED MODE)

The EUT has been tested as an independent unit together with other necessary accessories or support units. The following support units or accessories were used to form a representative test configuration during the tests.

| Item | Equipment                                | Mfr/Brand | Model/Type No. | Series No. | Note   |
|------|--|-----------|----------------|------------|--|
| E-1  | Waterproof Bluetooth speaker with sucker | N/A       | SM3740         | N/A        | EUT  |
| E-2  | Adapter                                  | N/A       | A8A-501000     | N/A        | Input:100-240V~<br>50/60Hz 0.2A<br>Output: 5.0V---1000mA |
|      |  |           |                |            |  |
|      |  |           |                |            |  |

| Item | Shielded Type | Ferrite Core | Length | Note                 |
|------|---------------|--------------|--------|----------------------|
| C-1  | NO            | NO           | 0.8M   | USB cable unshielded |

Note:

- (1) The support equipment was authorized by Declaration of Confirmation.
- (2) For detachable type I/O cable should be specified the length in cm in 『Length』 column.





## 2.5 EQUIPMENTS LIST FOR ALL TEST ITEMS

### Radiation Test equipment

| Item | Kind of Equipment  | Manufacturer | Type No.  | Serial No.    | Last calibration | Calibrated until |
|------|--------------------|--------------|-----------|---------------|------------------|------------------|
| 1    | Spectrum Analyzer  | Agilent      | E4407B    | MY45109572    | 2016.08.27       | 2017.08.26       |
| 2    | Test Receiver      | R&S          | ESPI      | 101396        | 2016.08.27       | 2017.08.26       |
| 3    | Bilog Antenna      | SCHWARZBECK  | VULB9160  | VULB9160-3369 | 2016.08.27       | 2017.08.26       |
| 4    | 50Ω Coaxial Switch | Anritsu      | MP59B     | 6200264416    | 2016.08.27       | 2017.08.26       |
| 5    | Spectrum Analyzer  | Agilent      | N9020A    | MY5051041     | 2016.08.27       | 2017.08.26       |
| 6    | Horn Antenna       | SCHWARZBECK  | 9120D     | 9120D-1275    | 2016.08.27       | 2017.08.26       |
| 7    | Horn Ant           | Schwarzbeck  | BBHA 9170 | 9170-181      | 2016.09.03       | 2017.09.02       |
| 8    | Amplifier          | SCHWARZBECK  | BBV9718   | 9718-270      | 2016.08.27       | 2017.08.26       |
| 9    | Amplifier          | SCHWARZBECK  | BBV9743   | 9743-119      | 2016.08.27       | 2017.08.26       |
| 10   | Loop Antenna       | ARA          | PLES130/B | 1029          | 2016.09.04       | 2017.09.03       |
| 11   | Power Meter        | R&S          | NRVS      | 100696        | 2016.08.27       | 2017.08.26       |
| 12   | Power Sensor       | R&S          | URV5-Z4   | 0395.1619.05  | 2016.08.27       | 2017.08.26       |
| 13   | RF cables          | R&S          | N/A       | N/A           | 2016.08.27       | 2017.08.26       |

### Conduction Test equipment

| Item | Kind of Equipment  | Manufacturer | Type No. | Serial No.             | Last calibration | Calibrated until |
|------|--------------------|--------------|----------|------------------------|------------------|------------------|
| 1    | Test Receiver      | R&S          | ESCI     | 1166.5950K03-101165-ha | 2016.08.27       | 2017.08.26       |
| 2    | LISN               | R&S          | NSLK8126 | 8126466                | 2016.08.27       | 2017.08.26       |
| 3    | LISN               | R&S          | NSLK8126 | 8126487                | 2016.08.27       | 2017.08.26       |
| 4    | 50Ω Coaxial Switch | Anritsu      | MP59B    | 6200264417             | 2016.08.27       | 2017.08.26       |
| 5    | RF cables          | R&S          | R204     | R20X                   | 2016.08.27       | 2017.08.26       |



### 3. EMC EMISSION TEST

#### 3.1 CONDUCTED EMISSION MEASUREMENT

##### 3.1.1 POWER LINE CONDUCTED EMISSION Limits (Frequency Range 150KHz-30MHz)

| FREQUENCY (M z) | Class A (dBuV) |         | Class B (dBuV) |           | Standard |
|-----------------|----------------|---------|----------------|-----------|----------|
|                 | Quasi-peak     | Average | Quasi-peak     | Average   |          |
| 0.15 -0.5       | 79.00          | 66.00   | 66 - 56 *      | 56 - 46 * | FCC      |
| 0.50 -5.0       | 73.00          | 60.00   | 56.00          | 46.00     | FCC      |
| 5.0 -30.0       | 73.00          | 60.00   | 60.00          | 50.00     | FCC      |

Note:

- (1) The tighter limit applies at the band edges.
- (2) The limit of " \* " marked band means the limitation decreases linearly with the logarithm of the frequency in the range.

The following table is the setting of the receiver

| Receiver Parameters | Setting  |
|---------------------|----------|
| Attenuation         | 10 dB    |
| Start Frequency     | 0.15 MHz |
| Stop Frequency      | 30 MHz   |
| IF Bandwidth        | 9 kHz    |

##### 3.1.2 TEST PROCEDURE

- a. The EUT was placed 0.8 meters from the horizontal ground plane with EUT being connected to the power mains through a line impedance stabilization network (LISN). All other support equipments powered from additional LISN(s). The LISN provide 50 Ohm/ 50uH of coupling impedance for the measuring instrument.
- b. Interconnecting cables that hang closer than 40 cm to the ground plane shall be folded back and forth in the center forming a bundle 30 to 40 cm long.
- c. I/O cables that are not connected to a peripheral shall be bundled in the center. The end of the cable may be terminated, if required, using the correct terminating impedance. The overall length shall not exceed 1 m.
- d. LISN at least 80 cm from nearest part of EUT chassis.
- e. For the actual test configuration, please refer to the related Item –EUT Test Photos.

##### 3.1.3 DEVIATION FROM TEST STANDARD

No deviation

### 3.1.4 TEST SETUP

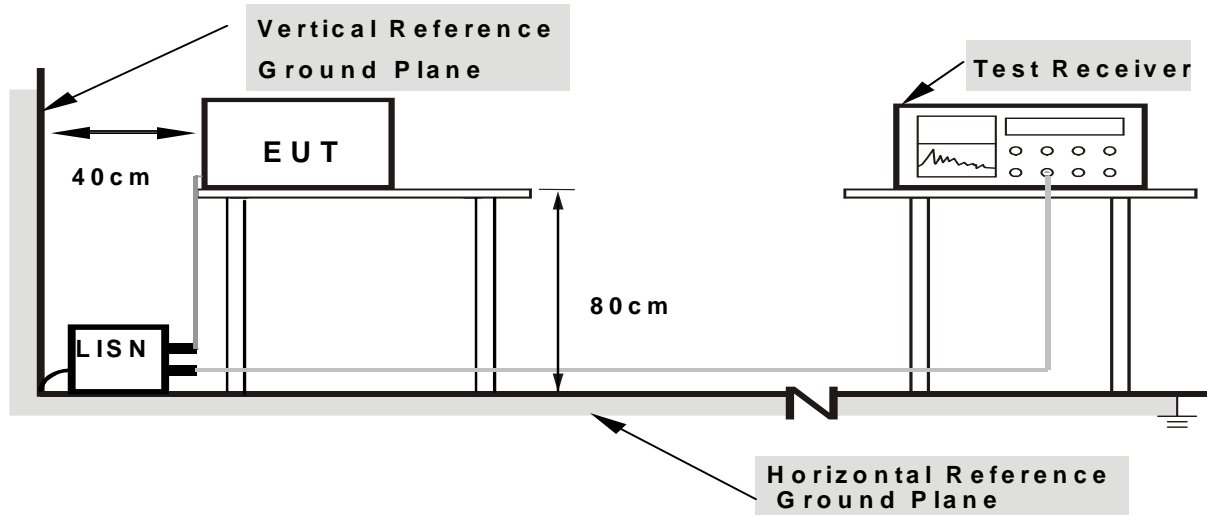

Note: 1.Support units were connected to second LISN.

2.Both of LISNs (AMN) are 80 cm from EUT and at least 80 from other units and other metal planes

### 3.1.5 EUT OPERATING CONDITIONS

The EUT was configured for testing in a typical fashion (as a customer would normally use it). The EUT has been programmed to continuously transmit during test. This operating condition was tested and used to collect the included data.

### 3.1.6 TEST RESULTS



|                |                                  |                     |        |
|----------------|----------------------------------|---------------------|--------|
| Temperature :  | 25 °C                            | Relative Humidity : | 54%    |
| Pressure :     | 1010hPa                          | Phase :             | L      |
| Test Voltage : | DC 5V from PC input AC 120V/60Hz | Test Mode :         | Mode 4 |

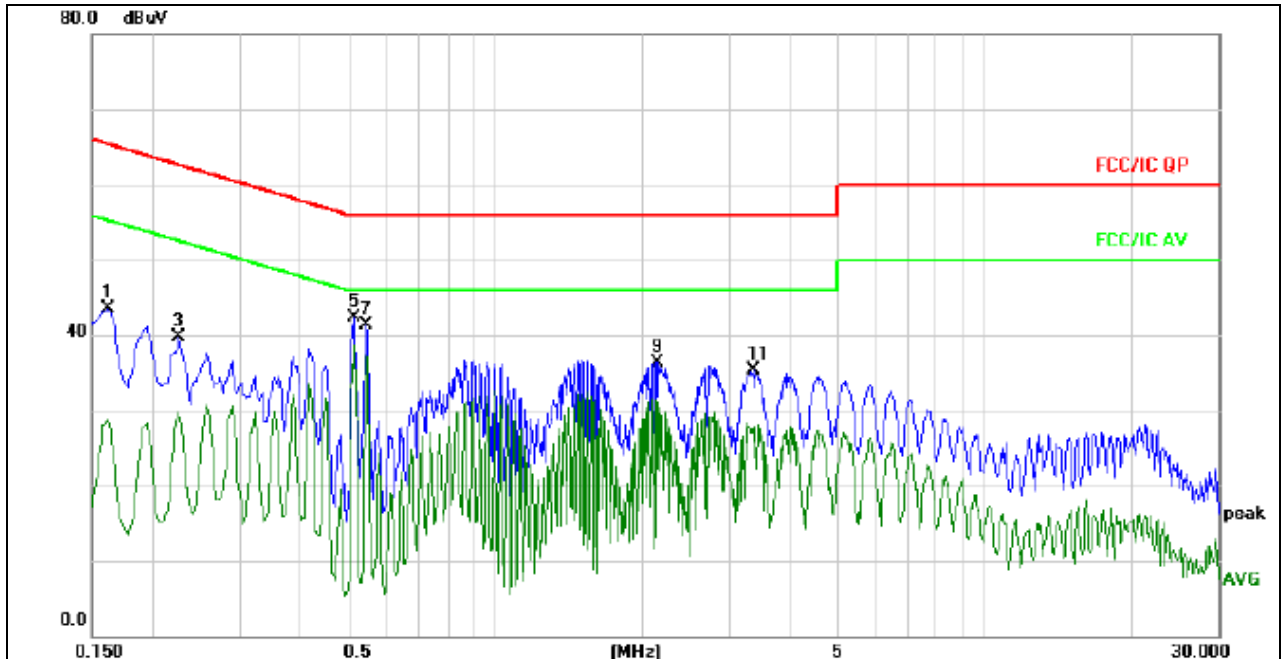

Remark:

1. All readings are Quasi-Peak and Average values.
2. Factor = Insertion Loss + Cable Loss.

| No. | Mk. | Freq. MHz | Reading Level dBuV | Correct Factor dB | Measurement dBuV | Limit dBuV | Over dB | Detector | Comment |
|-----|-----|-----------|--------------------|-------------------|------------------|------------|---------|----------|---------|
| 1   |     | 0.1620    | 33.80              | 9.67              | 43.47            | 65.36      | -21.89  | QP       |         |
| 2   |     | 0.1620    | 19.09              | 9.67              | 28.76            | 55.36      | -26.60  | AVG      |         |
| 3   |     | 0.2260    | 29.98              | 9.65              | 39.63            | 62.60      | -22.97  | QP       |         |
| 4   |     | 0.2260    | 20.09              | 9.65              | 29.74            | 52.60      | -22.86  | AVG      |         |
| 5   |     | 0.5140    | 32.63              | 9.68              | 42.31            | 56.00      | -13.69  | QP       |         |
| 6   | *   | 0.5140    | 28.99              | 9.68              | 38.67            | 46.00      | -7.33   | AVG      |         |
| 7   |     | 0.5460    | 31.57              | 9.68              | 41.25            | 56.00      | -14.75  | QP       |         |
| 8   |     | 0.5460    | 27.56              | 9.68              | 37.24            | 46.00      | -8.76   | AVG      |         |
| 9   |     | 2.1540    | 26.62              | 9.72              | 36.34            | 56.00      | -19.66  | QP       |         |
| 10  |     | 2.1540    | 21.74              | 9.72              | 31.46            | 46.00      | -14.54  | AVG      |         |
| 11  |     | 3.3740    | 25.61              | 9.72              | 35.33            | 56.00      | -20.67  | QP       |         |
| 12  |     | 3.3740    | 18.51              | 9.72              | 28.23            | 46.00      | -17.77  | AVG      |         |



|                |                                  |                     |        |
|----------------|----------------------------------|---------------------|--------|
| Temperature :  | 25 °C                            | Relative Humidity : | 54%    |
| Pressure :     | 1010hPa                          | Phase :             | N      |
| Test Voltage : | DC 5V from PC input AC 120V/60Hz | Test Mode :         | Mode 4 |

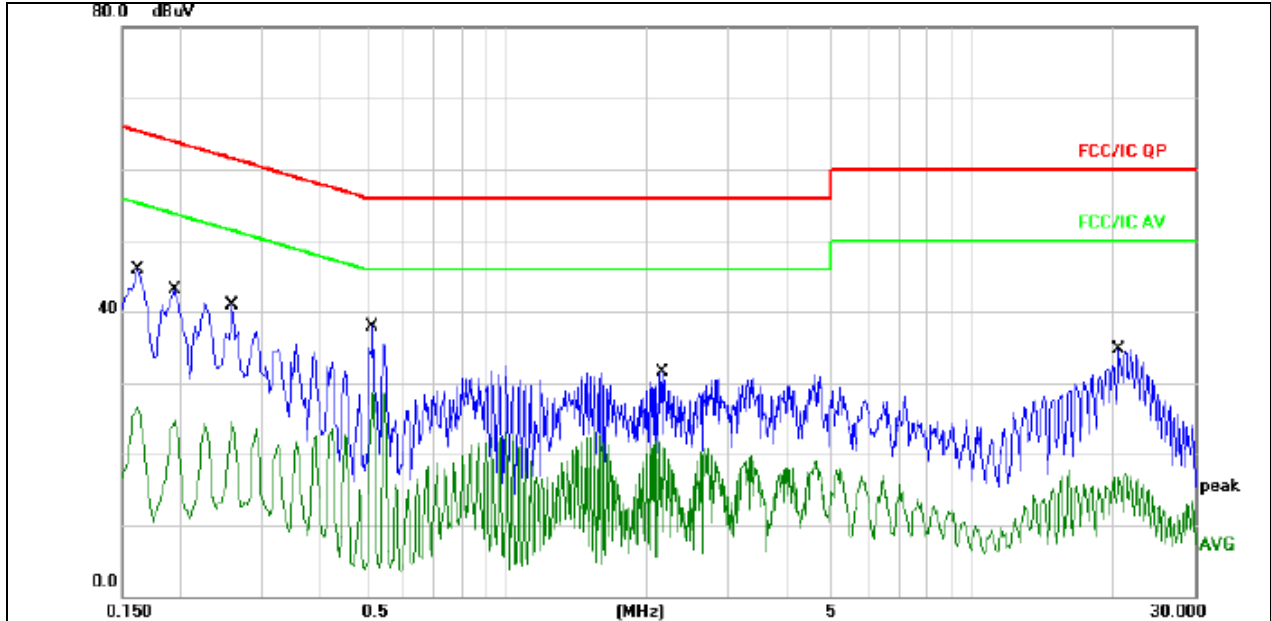

Remark:

1. All readings are Quasi-Peak and Average values.
2. Factor = Insertion Loss + Cable Loss.

| No. | Mk. | Freq.<br>MHz | Reading<br>Level<br>dBuV | Correct<br>Factor<br>dB | Measure-<br>ment<br>dBuV | Limit<br>dBuV | Over<br>dB | Detector | Comment |
|-----|-----|--------------|--------------------------|-------------------------|--------------------------|---------------|------------|----------|---------|
| 1   |     | 0.1620       | 36.14                    | 9.67                    | 45.81                    | 65.36         | -19.55     | QP       |         |
| 2   |     | 0.1620       | 16.92                    | 9.67                    | 26.59                    | 55.36         | -28.77     | AVG      |         |
| 3   |     | 0.1940       | 33.51                    | 9.65                    | 43.16                    | 63.86         | -20.70     | QP       |         |
| 4   |     | 0.1940       | 15.06                    | 9.65                    | 24.71                    | 53.86         | -29.15     | AVG      |         |
| 5   |     | 0.2580       | 31.21                    | 9.66                    | 40.87                    | 61.49         | -20.62     | QP       |         |
| 6   |     | 0.2580       | 14.81                    | 9.66                    | 24.47                    | 51.49         | -27.02     | AVG      |         |
| 7   |     | 0.5180       | 28.14                    | 9.68                    | 37.82                    | 56.00         | -18.18     | QP       |         |
| 8   | *   | 0.5180       | 18.95                    | 9.68                    | 28.63                    | 46.00         | -17.37     | AVG      |         |
| 9   |     | 2.1619       | 21.80                    | 9.72                    | 31.52                    | 56.00         | -24.48     | QP       |         |
| 10  |     | 2.1619       | 12.22                    | 9.72                    | 21.94                    | 46.00         | -24.06     | AVG      |         |
| 11  |     | 20.7020      | 24.80                    | 9.85                    | 34.65                    | 60.00         | -25.35     | QP       |         |
| 12  |     | 20.7020      | 7.35                     | 9.85                    | 17.20                    | 50.00         | -32.80     | AVG      |         |



### 3.2 RADIATED EMISSION MEASUREMENT

#### 3.2.1 RADIATED EMISSION LIMITS (Frequency Range 9kHz-1000MHz)

In case the emission fall within the restricted band specified on 15.205(a), then the 15.209(a) limit in the table below has to be followed.

| Frequencies (MHz) | Field Strength (micorvolts/meter) | Measurement Distance (meters) |
|-------------------|-----------------------------------|-------------------------------|
| 0.009~0.490       | 2400/F(KHz)                       | 300                           |
| 0.490~1.705       | 24000/F(KHz)                      | 30                            |
| 1.705~30.0        | 30                                | 30                            |
| 30~88             | 100                               | 3                             |
| 88~216            | 150                               | 3                             |
| 216~960           | 200                               | 3                             |
| Above 960         | 500                               | 3                             |

#### LIMITS OF RADIATED EMISSION MEASUREMENT (Above 1000MHz)

| FREQUENCY (MHz) | Class B (dBuV/m) (at 3M) |         |
|-----------------|--------------------------|---------|
|                 | PEAK                     | AVERAGE |
| Above 1000      | 74                       | 54      |

Notes:

- (1) The limit for radiated test was performed according to FCC PART 15C.
- (2) The tighter limit applies at the band edges.
- (3) Emission level (dBuV/m)=20log Emission level (uV/m).

| Spectrum Parameter                    | Setting  |
|---------------------------------------|--|
| Attenuation                           | Auto   |
| Start Frequency                       | 1000 MHz   |
| Stop Frequency                        | 25GHz  |
| RB / VB (emission in restricted band) | 1 MHz / 1 MHz for Peak, 1 MHz / 10Hz for Average |

| Receiver Parameter     | Setting                          |
|------------------------|----------------------------------|
| Attenuation            | Auto                             |
| Start ~ Stop Frequency | 9kHz~150kHz / RB 200Hz for QP    |
| Start ~ Stop Frequency | 150kHz~30MHz / RB 9kHz for QP    |
| Start ~ Stop Frequency | 30MHz~1000MHz / RB 120kHz for QP |

### 3.2.2 TEST PROCEDURE

Below 1GHz test procedure as below:

- a. The EUT was placed on the top of a rotating table 0.8 meters above the ground at a 3 meter semi-anechoic chamber. The table was rotated 360 degrees to determine the position of the highest radiation.
- b. The EUT was set 3 meters away from the interference-receiving antenna, which was mounted on the top of a variable-height antenna tower.
- c. The antenna height is varied from one meter to four meters above the ground to determine the maximum value of the field strength. Both horizontal and vertical polarizations of the antenna are set to make the measurement.
- d. For each suspected emission, the EUT was arranged to its worst case and then the antenna was tuned to heights from 1 meter to 4 meters (for the test frequency of below 30MHz, the antenna was tuned to heights 1 meter) and the rotatable table was turned from 0 degrees to 360 degrees to find the maximum reading.
- e. The test-receiver system was set to Peak Detect Function and Specified Bandwidth with Maximum Hold Mode.
- f. If the emission level of the EUT in peak mode was 10dB lower than the limit specified, then testing could be stopped and the peak values of the EUT would be reported. Otherwise the emissions that did not have 10dB margin would be re-tested one by one using peak, quasi-peak or average method as specified and then reported in a data sheet.

Above 1GHz test procedure as below:

- g. Different between above is the test site, change from Semi- Anechoic Chamber to fully Anechoic Chamber and change form table 0.8 metre to 1.5 metre( Above 18GHz the distance is 1 meter and table is 1.5 metre).
- h. Test the EUT in the lowest channel ,the middle channel ,the Highest channel

Note:

Both horizontal and vertical antenna polarities were tested and performed pretest to three orthogonal axis. The worst case emissions were reported

### 3.2.3 DEVIATION FROM TEST STANDARD

No deviation

### 3.2.4 TEST SETUP

(A) Radiated Emission Test-Up Frequency Below 30MHz

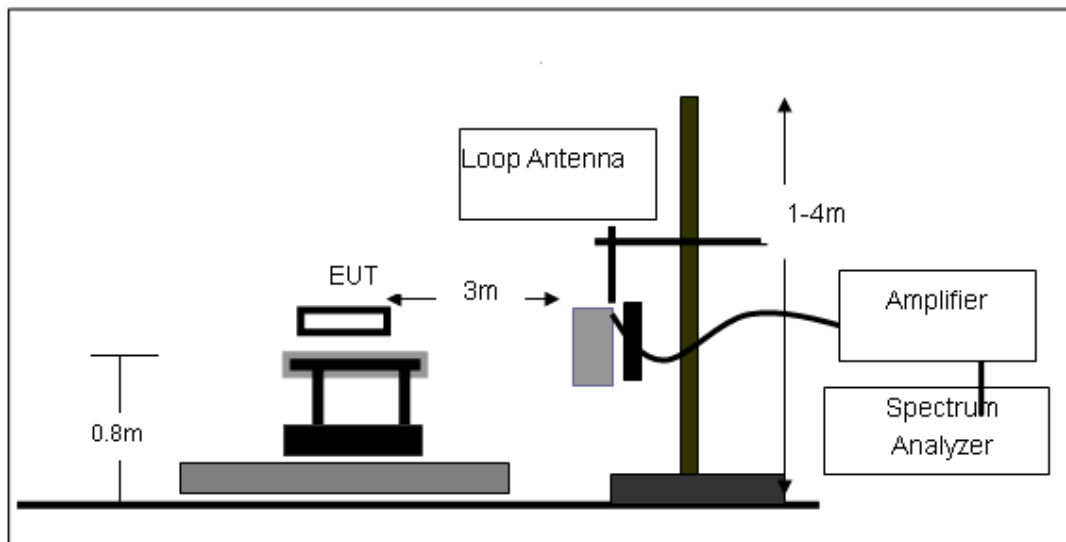

(B) Radiated Emission Test-Up Frequency 30MHz~1GHz

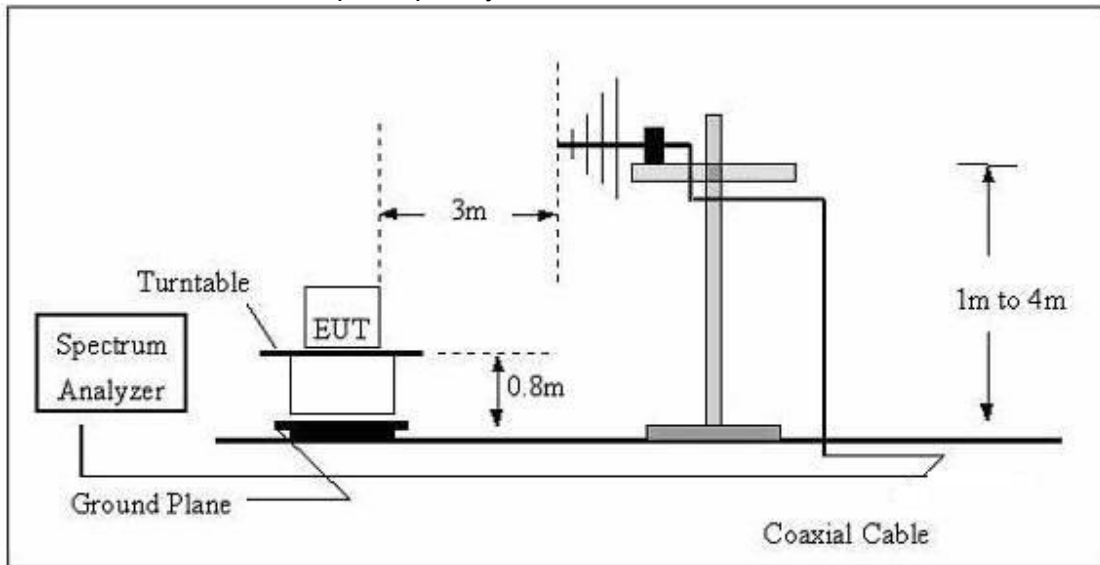

(C) Radiated Emission Test-Up Frequency Above 1GHz

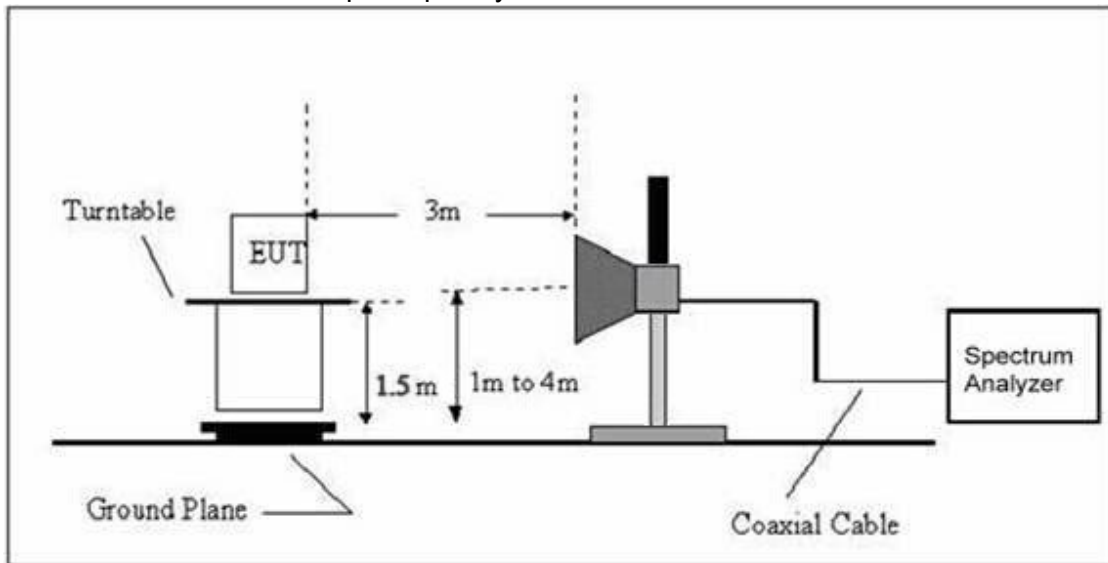

**3.2.5 EUT OPERATING CONDITIONS**

The EUT tested system was configured as the statements of 2.3 Unless otherwise a special operating condition is specified in the follows during the testing.



**3.2.6 TEST RESULTS (BETWEEN 9KHZ – 30 MHZ)**

|              |          |                    |         |
|--------------|----------|--------------------|---------|
| Temperature: | 20℃      | Relative Humidity: | 48%     |
| Pressure:    | 1010 hPa | Test Voltage :     | DC 3.7V |
| Test Mode :  | Mode 4   | Polarization :     | --      |

| Freq.<br>(MHz) | Reading<br>(dBuV/m) | Limit<br>(dBuV/m) | Margin<br>(dB) | State<br>P/F |
|----------------|---------------------|-------------------|----------------|--------------|
| --             | --                  | --                | --             | PASS         |
| --             | --                  | --                | --             | PASS         |

**NOTE:**

The amplitude of spurious emissions which are attenuated by more than 20dB below the permissible value has no need to be reported.

Distance extrapolation factor =  $40 \log(\text{specific distance}/\text{test distance})(\text{dB})$ ;

Limit line = specific limits(dBuv) + distance extrapolation factor.



**3.2.7 TEST RESULTS (BETWEEN 30MHZ – 1GHZ)**

|                |          |                     |            |
|----------------|----------|---------------------|------------|
| Temperature :  | 26°C     | Relative Humidity : | 54%        |
| Pressure :     | 1010 hPa | Polarization :      | Horizontal |
| Test Voltage : | DC 3.7V  |                     |            |
| Test Mode :    | Mode 4   |                     |            |

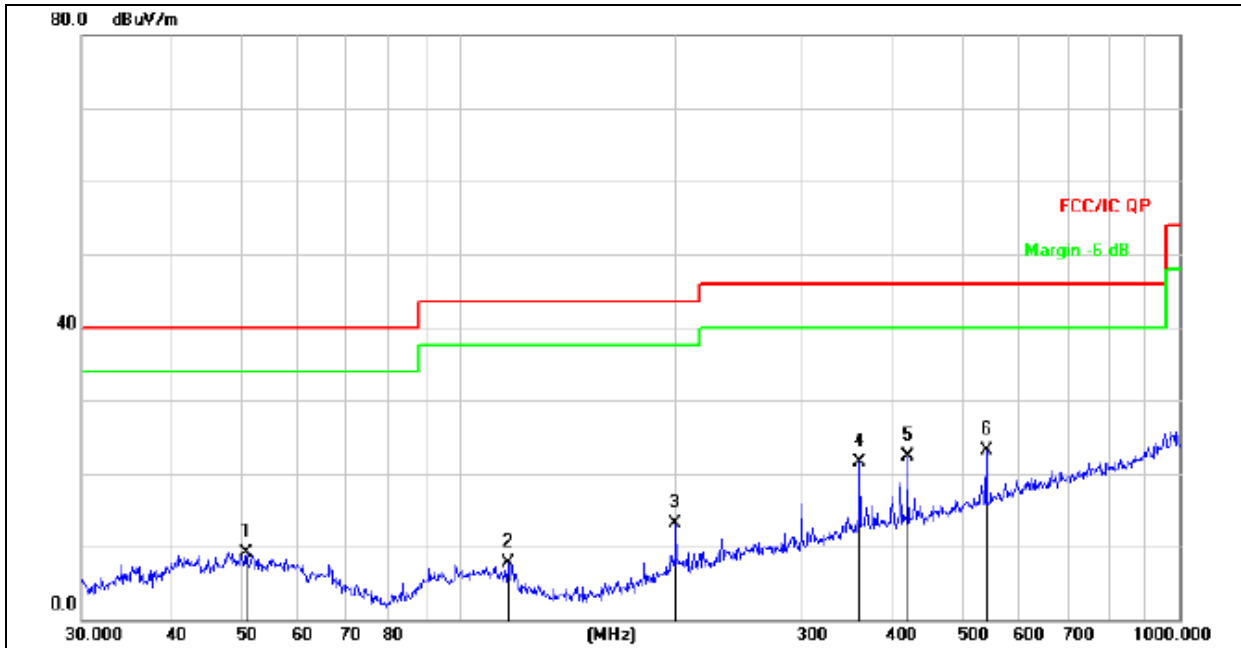

Remark:  
Factor = Antenna Factor + Cable Loss – Pre-amplifier.

| No. | Mk. | Freq.<br>MHz | Reading<br>Level<br>dBuV | Correct<br>Factor<br>dB | Measure-<br>ment<br>dBuV/m | Limit<br>dB/m | Over<br>dB | Detector |
|-----|-----|--------------|--------------------------|-------------------------|----------------------------|---------------|------------|----------|
| 1   |     | 50.7637      | 23.82                    | -14.76                  | 9.06                       | 40.00         | -30.94     | QP       |
| 2   |     | 116.9495     | 25.23                    | -17.57                  | 7.66                       | 43.50         | -35.84     | QP       |
| 3   |     | 199.9856     | 28.79                    | -15.63                  | 13.16                      | 43.50         | -30.34     | QP       |
| 4   |     | 360.4476     | 31.93                    | -10.40                  | 21.53                      | 46.00         | -24.47     | QP       |
| 5   |     | 419.1081     | 31.21                    | -8.88                   | 22.33                      | 46.00         | -23.67     | QP       |
| 6   | *   | 539.4775     | 29.47                    | -6.28                   | 23.19                      | 46.00         | -22.81     | QP       |



|                |          |                     |          |
|----------------|----------|---------------------|----------|
| Temperature :  | 26°C     | Relative Humidity : | 54%      |
| Pressure :     | 1010 hPa | Polarization :      | Vertical |
| Test Voltage : | DC 3.7V  |                     |          |
| Test Mode :    | Mode 4   |                     |          |

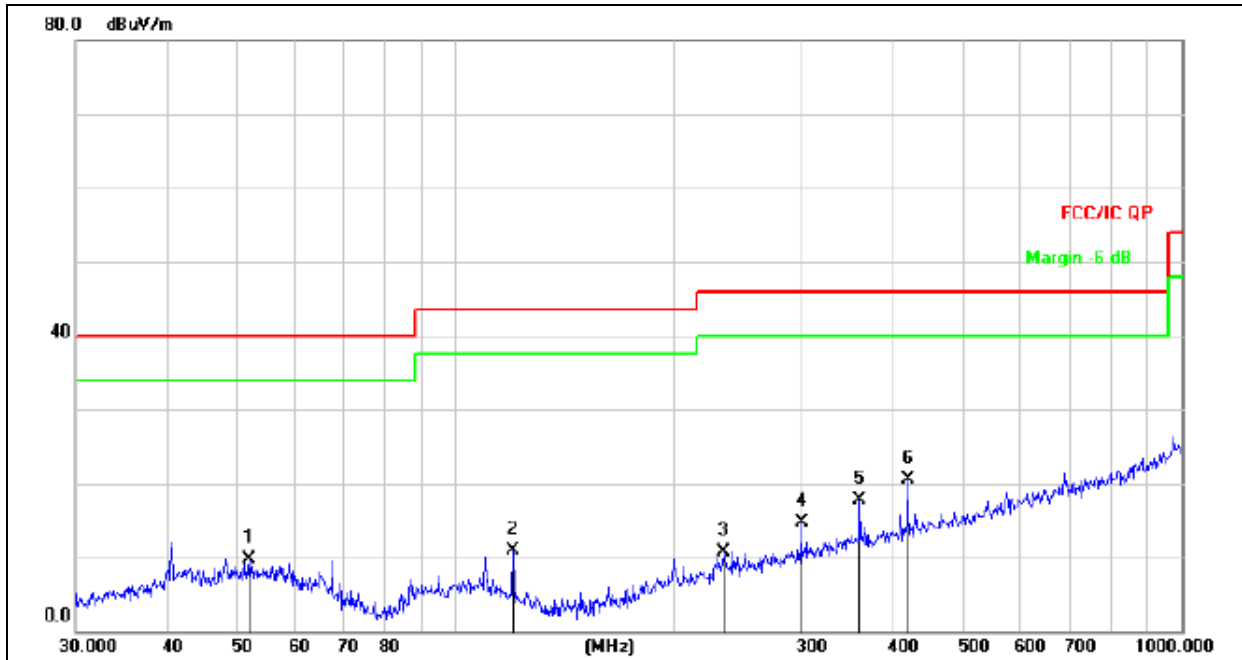

Remark:  
Factor = Antenna Factor + Cable Loss – Pre-amplifier.

| No. | Mk. | Freq.<br>MHz | Reading<br>Level<br>dBuV | Correct<br>Factor<br>dB | Measure-<br>ment<br>dBuV/m | Limit<br>dB/m | Over<br>dB | Detector |
|-----|-----|--------------|--------------------------|-------------------------|----------------------------|---------------|------------|----------|
| 1   |     | 51.8430      | 24.54                    | -14.75                  | 9.79                       | 40.00         | -30.21     | QP       |
| 2   |     | 119.8556     | 28.96                    | -18.07                  | 10.89                      | 43.50         | -32.61     | QP       |
| 3   |     | 234.1684     | 25.17                    | -14.37                  | 10.80                      | 46.00         | -35.20     | QP       |
| 4   |     | 299.3158     | 26.75                    | -12.12                  | 14.63                      | 46.00         | -31.37     | QP       |
| 5   |     | 360.4476     | 28.16                    | -10.40                  | 17.76                      | 46.00         | -28.24     | QP       |
| 6   | *   | 419.1081     | 29.34                    | -8.88                   | 20.46                      | 46.00         | -25.54     | QP       |



**3.2.8 TEST RESULTS (1GHZ~25GHZ)**

**GFSK**

| Polar (H/V)                     | Frequency | Meter Reading | Pre-amplifier | Cable Loss | Antenna Factor | Emission Level | Limits   | Margin | Detector Type |
|---------------------------------|-----------|---------------|---------------|------------|----------------|----------------|----------|--------|---------------|
|                                 | (MHz)     | (dBuV)        | (dB)          | (dB)       | (dB/m)         | (dBuV/m)       | (dBuV/m) | (dB)   |               |
| <b>operation frequency:2402</b> |           |               |               |            |                |                |          |        |               |
| V                               | 2402.00   | 110.37        | 38.06         | 7.42       | 20.15          | 99.88          | 114.00   | -14.12 | PK            |
| V                               | 2402.00   | 98.07         | 38.06         | 7.42       | 20.15          | 87.58          | 94.00    | -6.42  | AV            |
| V                               | 4804.00   | 59.54         | 38.53         | 7.78       | 23.25          | 52.04          | 74.00    | -21.96 | PK            |
| V                               | 4804.00   | 45.87         | 38.53         | 7.78       | 23.25          | 38.37          | 54.00    | -15.63 | AV            |
| V                               | 16132.00  | 50.09         | 38.75         | 10.36      | 26.57          | 48.27          | 74.00    | -25.73 | PK            |
| H                               | 2402.00   | 111.34        | 38.06         | 7.42       | 20.15          | 100.85         | 114.00   | -13.15 | PK            |
| H                               | 2402.00   | 97.66         | 38.06         | 7.42       | 20.15          | 87.17          | 94.00    | -6.83  | AV            |
| H                               | 4804.00   | 60.37         | 38.53         | 7.78       | 23.25          | 52.87          | 74.00    | -21.13 | PK            |
| H                               | 4804.00   | 45.75         | 38.53         | 7.78       | 23.25          | 38.25          | 54.00    | -15.75 | AV            |
| H                               | 16132.00  | 49.83         | 38.75         | 10.36      | 26.57          | 48.01          | 74.00    | -25.99 | PK            |
| <b>operation frequency:2440</b> |           |               |               |            |                |                |          |        |               |
| V                               | 2440.00   | 110.87        | 38.11         | 7.42       | 20.36          | 100.54         | 114.00   | -13.46 | PK            |
| V                               | 2440.00   | 98.22         | 38.11         | 7.42       | 20.36          | 87.89          | 94.00    | -6.11  | AV            |
| V                               | 4880.00   | 60.47         | 38.65         | 7.78       | 23.61          | 53.21          | 74.00    | -20.79 | PK            |
| V                               | 4880.00   | 45.91         | 38.65         | 7.78       | 23.61          | 38.65          | 54.00    | -15.35 | AV            |
| V                               | 16132.00  | 48.34         | 38.75         | 10.36      | 26.57          | 46.52          | 74.00    | -27.48 | PK            |
| H                               | 2440.00   | 110.89        | 38.11         | 7.42       | 20.36          | 100.56         | 114.00   | -13.44 | PK            |
| H                               | 2440.00   | 98.09         | 38.11         | 7.42       | 20.36          | 87.76          | 94.00    | -6.24  | AV            |
| H                               | 4880.00   | 61.54         | 38.65         | 7.78       | 23.61          | 54.28          | 74.00    | -19.72 | PK            |
| H                               | 4880.00   | 46.63         | 38.65         | 7.78       | 23.61          | 39.37          | 54.00    | -14.63 | AV            |
| H                               | 16132.00  | 50.00         | 38.75         | 10.36      | 26.57          | 48.18          | 74.00    | -25.82 | PK            |
| <b>operation frequency:2480</b> |           |               |               |            |                |                |          |        |               |
| V                               | 2480.00   | 111.92        | 38.17         | 7.42       | 20.51          | 101.68         | 114.00   | -12.32 | PK            |
| V                               | 2480.00   | 99.31         | 38.17         | 7.42       | 20.51          | 89.07          | 94.00    | -4.93  | AV            |
| V                               | 4960.00   | 61.29         | 38.69         | 7.78       | 23.83          | 54.21          | 74.00    | -19.79 | PK            |
| V                               | 4960.00   | 46.19         | 38.69         | 7.78       | 23.83          | 39.11          | 54.00    | -14.89 | AV            |
| V                               | 16132.00  | 50.22         | 38.75         | 10.36      | 26.57          | 48.4           | 74.00    | -25.6  | PK            |
| H                               | 2480.00   | 110.95        | 38.17         | 7.42       | 20.51          | 100.71         | 114.00   | -13.29 | PK            |
| H                               | 2480.00   | 99.17         | 38.17         | 7.42       | 20.51          | 88.93          | 94.00    | -5.07  | AV            |
| H                               | 4960.00   | 61.49         | 38.69         | 7.78       | 23.83          | 54.41          | 74.00    | -19.59 | PK            |
| H                               | 4960.00   | 46.22         | 38.69         | 7.78       | 23.83          | 39.14          | 54.00    | -14.86 | AV            |
| H                               | 16132.00  | 50.54         | 38.75         | 10.36      | 26.57          | 48.72          | 74.00    | -25.28 | PK            |

**Remark:**

1. Emission Level = Meter Reading + Antenna Factor + Cable Loss – Pre-amplifier, Margin= Emission Level - Limit
2. If peak below the average limit, the average emission was no test.
3. The amplitude of spurious emissions which are attenuated by more than 20dB below the permissible value has no need to be reported.



PI/4 DPSK

| Polar (H/V)                     | Frequency | Meter Reading | Pre-amplifier | Cable Loss | Antenna Factor | Emission Level | Limits   | Margin | Detector Type |
|---------------------------------|-----------|---------------|---------------|------------|----------------|----------------|----------|--------|---------------|
|                                 | (MHz)     | (dBuV)        | (dB)          | (dB)       | (dB/m)         | (dBuV/m)       | (dBuV/m) | (dB)   |               |
| <b>operation frequency:2402</b> |           |               |               |            |                |                |          |        |               |
| V                               | 2402.00   | 110.40        | 38.06         | 7.42       | 20.15          | 99.91          | 114.00   | -14.09 | PK            |
| V                               | 2402.00   | 97.24         | 38.06         | 7.42       | 20.15          | 86.75          | 94.00    | -7.25  | AV            |
| V                               | 4804.00   | 59.01         | 38.53         | 7.78       | 23.25          | 51.51          | 74.00    | -22.49 | PK            |
| V                               | 4804.00   | 45.46         | 38.53         | 7.78       | 23.25          | 37.96          | 54.00    | -16.04 | AV            |
| V                               | 16132.00  | 49.65         | 38.75         | 10.36      | 26.57          | 47.83          | 74.00    | -26.17 | PK            |
| H                               | 2402.00   | 110.37        | 38.06         | 7.42       | 20.15          | 99.88          | 114.00   | -14.12 | PK            |
| H                               | 2402.00   | 97.83         | 38.06         | 7.42       | 20.15          | 87.34          | 94.00    | -6.66  | AV            |
| H                               | 4804.00   | 59.83         | 38.53         | 7.78       | 23.25          | 52.33          | 74.00    | -21.67 | PK            |
| H                               | 4804.00   | 45.34         | 38.53         | 7.78       | 23.25          | 37.84          | 54.00    | -16.16 | AV            |
| H                               | 16132.00  | 49.39         | 38.75         | 10.36      | 26.57          | 47.57          | 74.00    | -26.43 | PK            |
| <b>operation frequency:2440</b> |           |               |               |            |                |                |          |        |               |
| V                               | 2440.00   | 110.90        | 38.11         | 7.42       | 20.36          | 100.57         | 114.00   | -13.43 | PK            |
| V                               | 2440.00   | 97.38         | 38.11         | 7.42       | 20.36          | 87.05          | 94.00    | -6.95  | AV            |
| V                               | 4880.00   | 59.93         | 38.65         | 7.78       | 23.61          | 52.67          | 74.00    | -21.33 | PK            |
| V                               | 4880.00   | 45.50         | 38.65         | 7.78       | 23.61          | 38.24          | 54.00    | -15.76 | AV            |
| V                               | 16132.00  | 47.91         | 38.75         | 10.36      | 26.57          | 46.09          | 74.00    | -27.91 | PK            |
| H                               | 2440.00   | 110.92        | 38.11         | 7.42       | 20.36          | 100.59         | 114.00   | -13.41 | PK            |
| H                               | 2440.00   | 98.25         | 38.11         | 7.42       | 20.36          | 87.92          | 94.00    | -6.08  | AV            |
| H                               | 4880.00   | 60.98         | 38.65         | 7.78       | 23.61          | 53.72          | 74.00    | -20.28 | PK            |
| H                               | 4880.00   | 46.22         | 38.65         | 7.78       | 23.61          | 38.96          | 54.00    | -15.04 | AV            |
| H                               | 16132.00  | 49.56         | 38.75         | 10.36      | 26.57          | 47.74          | 74.00    | -26.26 | PK            |
| <b>operation frequency:2480</b> |           |               |               |            |                |                |          |        |               |
| V                               | 2480.00   | 110.95        | 38.17         | 7.42       | 20.51          | 100.71         | 114.00   | -13.29 | PK            |
| V                               | 2480.00   | 92.45         | 38.17         | 7.42       | 20.51          | 82.21          | 94.00    | -11.79 | AV            |
| V                               | 4960.00   | 60.74         | 38.69         | 7.78       | 23.83          | 53.66          | 74.00    | -20.34 | PK            |
| V                               | 4960.00   | 45.78         | 38.69         | 7.78       | 23.83          | 38.7           | 54.00    | -15.30 | AV            |
| V                               | 16132.00  | 49.78         | 38.75         | 10.36      | 26.57          | 47.96          | 74.00    | -26.04 | PK            |
| H                               | 2480.00   | 110.98        | 38.17         | 7.42       | 20.51          | 100.74         | 114.00   | -13.26 | PK            |
| H                               | 2480.00   | 98.34         | 38.17         | 7.42       | 20.51          | 88.1           | 94.00    | -5.90  | AV            |
| H                               | 4960.00   | 60.93         | 38.69         | 7.78       | 23.83          | 53.85          | 74.00    | -20.15 | PK            |
| H                               | 4960.00   | 45.81         | 38.69         | 7.78       | 23.83          | 38.73          | 54.00    | -15.27 | AV            |
| H                               | 16132.00  | 50.09         | 38.75         | 10.36      | 26.57          | 48.27          | 74.00    | -25.73 | PK            |

**Remark:**

1. Emission Level = Meter Reading + Antenna Factor + Cable Loss – Pre-amplifier,  
Margin= Emission Level - Limit
2. If peak below the average limit, the average emission was no test.
3. The amplitude of spurious emissions which are attenuated by more than 20dB below the permissible value has no need to be reported.



8DPSK

| Polar (H/V)                     | Frequency | Meter Reading | Pre-amplifier | Cable Loss | Antenna Factor | Emission Level | Limits   | Margin | Detector Type |
|---------------------------------|-----------|---------------|---------------|------------|----------------|----------------|----------|--------|---------------|
|                                 | (MHz)     | (dBuV)        | (dB)          | (dB)       | (dB/m)         | (dBuV/m)       | (dBuV/m) | (dB)   |               |
| <b>operation frequency:2402</b> |           |               |               |            |                |                |          |        |               |
| V                               | 2402.00   | 110.72        | 38.06         | 7.42       | 20.15          | 100.23         | 114.00   | -13.77 | PK            |
| V                               | 2402.00   | 97.36         | 38.06         | 7.42       | 20.15          | 86.87          | 94.00    | -7.13  | AV            |
| V                               | 4804.00   | 59.73         | 38.53         | 7.78       | 23.25          | 52.23          | 74.00    | -21.77 | PK            |
| V                               | 4804.00   | 46.02         | 38.53         | 7.78       | 23.25          | 38.52          | 54.00    | -15.48 | AV            |
| V                               | 16132.00  | 50.25         | 38.75         | 10.36      | 26.57          | 48.43          | 74.00    | -25.57 | PK            |
| H                               | 2402.00   | 108.69        | 38.06         | 7.42       | 20.15          | 98.2           | 114.00   | -15.80 | PK            |
| H                               | 2402.00   | 93.96         | 38.06         | 7.42       | 20.15          | 83.47          | 94.00    | -10.53 | AV            |
| H                               | 4804.00   | 60.56         | 38.53         | 7.78       | 23.25          | 53.06          | 74.00    | -20.94 | PK            |
| H                               | 4804.00   | 45.90         | 38.53         | 7.78       | 23.25          | 38.4           | 54.00    | -15.60 | AV            |
| H                               | 16132.00  | 49.99         | 38.75         | 10.36      | 26.57          | 48.17          | 74.00    | -25.83 | PK            |
| <b>operation frequency:2440</b> |           |               |               |            |                |                |          |        |               |
| V                               | 2440.00   | 110.22        | 38.11         | 7.42       | 20.36          | 99.89          | 114.00   | -14.11 | PK            |
| V                               | 2440.00   | 97.50         | 38.11         | 7.42       | 20.36          | 87.17          | 94.00    | -6.83  | AV            |
| V                               | 4880.00   | 60.66         | 38.65         | 7.78       | 23.61          | 53.4           | 74.00    | -20.60 | PK            |
| V                               | 4880.00   | 46.06         | 38.65         | 7.78       | 23.61          | 38.8           | 54.00    | -15.20 | AV            |
| V                               | 16132.00  | 48.50         | 38.75         | 10.36      | 26.57          | 46.68          | 74.00    | -27.32 | PK            |
| H                               | 2440.00   | 110.24        | 38.11         | 7.42       | 20.36          | 99.91          | 114.00   | -14.09 | PK            |
| H                               | 2440.00   | 97.39         | 38.11         | 7.42       | 20.36          | 87.06          | 94.00    | -6.94  | AV            |
| H                               | 4880.00   | 61.73         | 38.65         | 7.78       | 23.61          | 54.47          | 74.00    | -19.53 | PK            |
| H                               | 4880.00   | 46.78         | 38.65         | 7.78       | 23.61          | 39.52          | 54.00    | -14.48 | AV            |
| H                               | 16132.00  | 50.16         | 38.75         | 10.36      | 26.57          | 48.34          | 74.00    | -25.66 | PK            |
| <b>operation frequency:2480</b> |           |               |               |            |                |                |          |        |               |
| V                               | 2480.00   | 110.27        | 38.17         | 7.42       | 20.51          | 100.03         | 114.00   | -13.97 | PK            |
| V                               | 2480.00   | 97.60         | 38.17         | 7.42       | 20.51          | 87.36          | 94.00    | -6.64  | AV            |
| V                               | 4960.00   | 61.48         | 38.69         | 7.78       | 23.83          | 54.4           | 74.00    | -19.60 | PK            |
| V                               | 4960.00   | 46.34         | 38.69         | 7.78       | 23.83          | 39.26          | 54.00    | -14.74 | AV            |
| V                               | 16132.00  | 50.38         | 38.75         | 10.36      | 26.57          | 48.56          | 74.00    | -25.44 | PK            |
| H                               | 2480.00   | 110.30        | 38.17         | 7.42       | 20.51          | 100.06         | 114.00   | -13.94 | PK            |
| H                               | 2480.00   | 97.45         | 38.17         | 7.42       | 20.51          | 87.21          | 94.00    | -6.79  | AV            |
| H                               | 4960.00   | 61.68         | 38.69         | 7.78       | 23.83          | 54.6           | 74.00    | -19.40 | PK            |
| H                               | 4960.00   | 46.37         | 38.69         | 7.78       | 23.83          | 39.29          | 54.00    | -14.71 | AV            |
| H                               | 16132.00  | 50.71         | 38.75         | 10.36      | 26.57          | 48.89          | 74.00    | -25.11 | PK            |

**Remark:**

1. Emission Level = Meter Reading + Antenna Factor + Cable Loss – Pre-amplifier,  
Margin= Emission Level - Limit
2. If peak below the average limit, the average emission was no test.
3. The amplitude of spurious emissions which are attenuated by more than 20dB below the permissible value has no need to be reported.



### 3.3 RADIATED BAND EMISSION MEASUREMENT

#### 3.3.1 TEST REQUIREMENT:

FCC Part15 C Section 15.209 and 15.205

LIMITS OF RADIATED EMISSION MEASUREMENT (Above 1000MHz)

| FREQUENCY (MHz) | Class B (dBuV/m) (at 3M) |         |
|-----------------|--------------------------|---------|
|                 | PEAK                     | AVERAGE |
| Above 1000      | 74                       | 54      |

Notes:

- (1) The limit for radiated test was performed according to FCC PART 15C.
- (2) The tighter limit applies at the band edges.
- (3) Emission level (dBuV/m)=20log Emission level (uV/m).

| Spectrum Parameter                    | Setting  |
|---------------------------------------|--|
| Attenuation                           | Auto   |
| Start Frequency                       | 2300MHz  |
| Stop Frequency                        | 2520   |
| RB / VB (emission in restricted band) | 1 MHz / 1 MHz for Peak, 1 MHz / 10Hz for Average |

#### 3.3.2 TEST PROCEDURE

Above 1GHz test procedure as below:

- a. 1. The EUT was placed on the top of a rotating table 1.5 meters above the ground at a 3 meter camber. The table was rotated 360 degrees to determine the position of the highest radiation.
- b. The EUT was set 3 meters away from the interference-receiving antenna, which was mounted on the top of a variable-height antenna tower.
- c. The antenna height is varied from one meter to four meters above the ground to determine the maximum value of the field strength. Both horizontal and vertical polarizations of the antenna are set to make the measurement.
- d. For each suspected emission, the EUT was arranged to its worst case and then the antenna was tuned to heights from 1 meter to 4 meters and the rota table was turned from 0 degrees to 360 degrees to find the maximum reading.
- e. The test-receiver system was set to Peak Detect Function and Specified Bandwidth with Maximum Hold Mode.
- f. If the emission level of the EUT in peak mode was 10dB lower than the limit specified, then testing could be stopped and the peak values of the EUT would be reported. Otherwise the emissions that did not have 10dB margin would be re-tested one by one using peak, quasi-peak or average method as specified and then reported in a data sheet.
- g. Test the EUT in the lowest channel, the Highest channel

Note:

Both horizontal and vertical antenna polarities were tested and performed pretest to three orthogonal axis. The worst case emissions were reported

### 3.3.3 DEVIATION FROM TEST STANDARD

No deviation

### 3.3.4 TEST SETUP

Radiated Emission Test-Up Frequency Above 1GHz

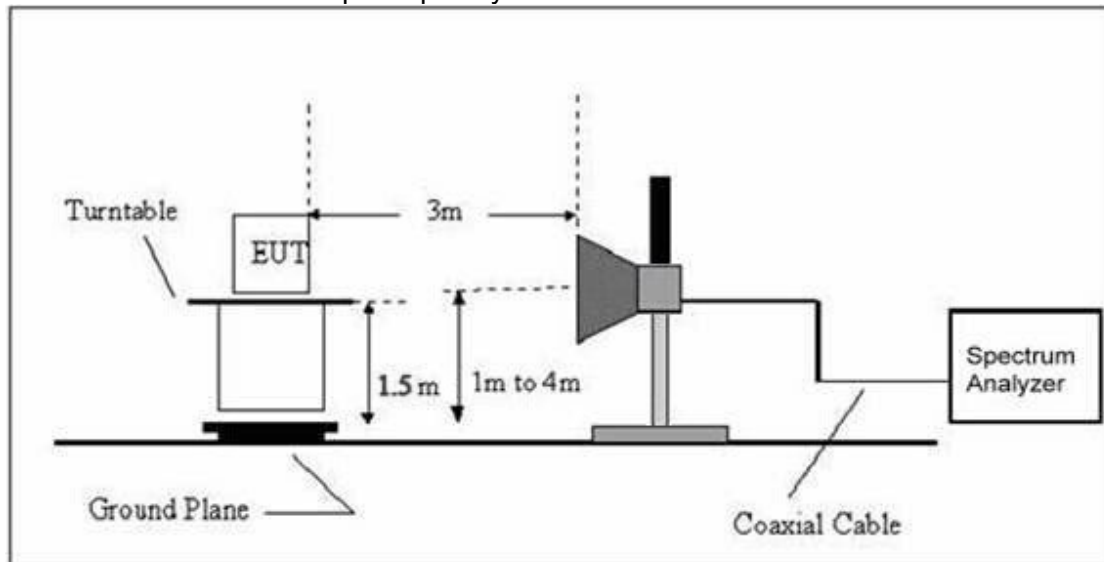

### 3.3.5 EUT OPERATING CONDITIONS

The EUT tested system was configured as the statements of 2.3 Unless otherwise a special operating condition is specified in the follows during the testing.

The plot only show the Horizontal's average data.





### 3.3.6 TEST RESULT

GFSK

| Polar (H/V)                     | Frequency | Meter Reading | Pre-amplifier | Cable Loss | Antenna Factor | Emission level | Limits   | Margin | Detector Type |
|---------------------------------|-----------|---------------|---------------|------------|----------------|----------------|----------|--------|---------------|
|                                 | (MHz)     | (dBuV)        | (dB)          | (dB)       | (dB/m)         | (dBuV/m)       | (dBuV/m) | (dB)   |               |
| <b>operation frequency:2402</b> |           |               |               |            |                |                |          |        |               |
| V                               | 2390.00   | 66.96         | 38.06         | 7.42       | 20.15          | 56.47          | 74.00    | -17.53 | PK            |
| V                               | 2390.00   | 55.63         | 38.06         | 7.42       | 20.15          | 45.14          | 54.00    | -8.86  | AV            |
| V                               | 2400.00   | 67.17         | 38.06         | 7.42       | 20.15          | 56.68          | 74.00    | -17.32 | PK            |
| V                               | 2400.00   | 55.21         | 38.06         | 7.42       | 20.15          | 44.72          | 54.00    | -9.28  | AV            |
| H                               | 2390.00   | 67.25         | 38.06         | 7.42       | 20.15          | 56.76          | 74.00    | -17.24 | PK            |
| H                               | 2390.00   | 55.66         | 38.06         | 7.42       | 20.15          | 45.17          | 54.00    | -8.83  | AV            |
| H                               | 2400.00   | 67.12         | 38.06         | 7.42       | 20.15          | 56.63          | 74.00    | -17.37 | PK            |
| H                               | 2400.00   | 55.60         | 38.06         | 7.42       | 20.15          | 45.11          | 54.00    | -8.89  | AV            |

| Polar (H/V)                     | Frequency | Meter Reading | Pre-amplifier | Cable Loss | Antenna Factor | Emission Level | Limits   | Margin | Detector Type |
|---------------------------------|-----------|---------------|---------------|------------|----------------|----------------|----------|--------|---------------|
|                                 | (MHz)     | (dBuV)        | (dB)          | (dB)       | (dB/m)         | (dBuV/m)       | (dBuV/m) | (dB)   |               |
| <b>operation frequency:2480</b> |           |               |               |            |                |                |          |        |               |
| V                               | 2483.50   | 67.17         | 38.17         | 7.42       | 20.51          | 56.93          | 74.00    | -17.07 | PK            |
| V                               | 2483.50   | 55.87         | 38.17         | 7.42       | 20.51          | 45.63          | 54.00    | -8.37  | AV            |
| V                               | 2500.00   | 67.11         | 38.20         | 7.45       | 20.54          | 56.9           | 74.00    | -17.10 | PK            |
| V                               | 2500.00   | 55.32         | 38.20         | 7.45       | 20.54          | 45.11          | 54.00    | -8.89  | AV            |
| H                               | 2483.50   | 67.29         | 38.17         | 7.42       | 20.51          | 57.05          | 74.00    | -16.95 | PK            |
| H                               | 2483.50   | 55.91         | 38.17         | 7.42       | 20.51          | 45.67          | 54.00    | -8.33  | AV            |
| H                               | 2500.00   | 66.91         | 38.20         | 7.45       | 20.54          | 56.7           | 74.00    | -17.30 | PK            |
| H                               | 2500.00   | 56.16         | 38.20         | 7.45       | 20.54          | 45.95          | 54.00    | -8.05  | AV            |

**Remark:**

1. Emission Level = Meter Reading + Factor, Margin= Emission Level - Limit
2. If peak below the average limit, the average emission was no test.
3. The amplitude of spurious emissions which are attenuated by more than 20dB below the permissible value has no need to be reported.



PI/4 DPSK

| Polar (H/V)                     | Frequency | Meter Reading | Pre-amplifier | Cable Loss | Antenna Factor | Emission level | Limits   | Margin | Detector Type |
|---------------------------------|-----------|---------------|---------------|------------|----------------|----------------|----------|--------|---------------|
|                                 | (MHz)     | (dBuV)        | (dB)          | (dB)       | (dB/m)         | (dBuV/m)       | (dBuV/m) | (dB)   |               |
| <b>operation frequency:2402</b> |           |               |               |            |                |                |          |        |               |
| V                               | 2390.00   | 67.12         | 38.06         | 7.42       | 20.15          | 56.63          | 74.00    | -17.37 | PK            |
| V                               | 2390.00   | 55.76         | 38.06         | 7.42       | 20.15          | 45.27          | 54.00    | -8.73  | AV            |
| V                               | 2400.00   | 67.33         | 38.06         | 7.42       | 20.15          | 56.84          | 74.00    | -17.16 | PK            |
| V                               | 2400.00   | 55.34         | 38.06         | 7.42       | 20.15          | 44.85          | 54.00    | -9.15  | AV            |
| H                               | 2390.00   | 67.41         | 38.06         | 7.42       | 20.15          | 56.92          | 74.00    | -17.08 | PK            |
| H                               | 2390.00   | 55.79         | 38.06         | 7.42       | 20.15          | 45.30          | 54.00    | -8.70  | AV            |
| H                               | 2400.00   | 67.28         | 38.06         | 7.42       | 20.15          | 56.79          | 74.00    | -17.21 | PK            |
| H                               | 2400.00   | 55.73         | 38.06         | 7.42       | 20.15          | 45.24          | 54.00    | -8.76  | AV            |

| Polar (H/V)                     | Frequency | Meter Reading | Pre-amplifier | Cable Loss | Antenna Factor | Emission Level | Limits   | Margin | Detector Type |
|---------------------------------|-----------|---------------|---------------|------------|----------------|----------------|----------|--------|---------------|
|                                 | (MHz)     | (dBuV)        | (dB)          | (dB)       | (dB/m)         | (dBuV/m)       | (dBuV/m) | (dB)   |               |
| <b>operation frequency:2480</b> |           |               |               |            |                |                |          |        |               |
| V                               | 2483.50   | 67.33         | 38.17         | 7.42       | 20.51          | 57.09          | 74.00    | -16.91 | PK            |
| V                               | 2483.50   | 56.00         | 38.17         | 7.42       | 20.51          | 45.76          | 54.00    | -8.24  | AV            |
| V                               | 2500.00   | 67.27         | 38.20         | 7.45       | 20.54          | 57.06          | 74.00    | -16.94 | PK            |
| V                               | 2500.00   | 55.45         | 38.20         | 7.45       | 20.54          | 45.24          | 54.00    | -8.76  | AV            |
| H                               | 2483.50   | 67.45         | 38.17         | 7.42       | 20.51          | 57.21          | 74.00    | -16.79 | PK            |
| H                               | 2483.50   | 56.04         | 38.17         | 7.42       | 20.51          | 45.80          | 54.00    | -8.20  | AV            |
| H                               | 2500.00   | 67.07         | 38.20         | 7.45       | 20.54          | 56.86          | 74.00    | -17.14 | PK            |
| H                               | 2500.00   | 56.29         | 38.20         | 7.45       | 20.54          | 46.08          | 54.00    | -7.92  | AV            |

**Remark:**

1. Emission Level = Meter Reading + Factor, Margin= Emission Level - Limit
2. If peak below the average limit, the average emission was no test.
3. The amplitude of spurious emissions which are attenuated by more than 20dB below the permissible value has no need to be reported.



8DPSK

| Polar (H/V)                     | Frequency | Meter Reading | Pre-amplifier | Cable Loss | Antenna Factor | Emission Level | Limits   | Margin | Detector Type |
|---------------------------------|-----------|---------------|---------------|------------|----------------|----------------|----------|--------|---------------|
|                                 | (MHz)     | (dBuV)        | (dB)          | (dB)       | (dB/m)         | (dBuV/m)       | (dBuV/m) | (dB)   |               |
| <b>operation frequency:2402</b> |           |               |               |            |                |                |          |        |               |
| V                               | 2390.00   | 67.46         | 38.06         | 7.42       | 20.15          | 56.97          | 74.00    | -17.03 | PK            |
| V                               | 2390.00   | 56.05         | 38.06         | 7.42       | 20.15          | 45.56          | 54.00    | -8.44  | AV            |
| V                               | 2400.00   | 67.68         | 38.06         | 7.42       | 20.15          | 57.19          | 74.00    | -16.81 | PK            |
| V                               | 2400.00   | 55.62         | 38.06         | 7.42       | 20.15          | 45.13          | 54.00    | -8.87  | AV            |
| H                               | 2390.00   | 67.76         | 38.06         | 7.42       | 20.15          | 57.27          | 74.00    | -16.73 | PK            |
| H                               | 2390.00   | 56.08         | 38.06         | 7.42       | 20.15          | 45.59          | 54.00    | -8.41  | AV            |
| H                               | 2400.00   | 67.62         | 38.06         | 7.42       | 20.15          | 57.13          | 74.00    | -16.87 | PK            |
| H                               | 2400.00   | 56.02         | 38.06         | 7.42       | 20.15          | 45.53          | 54.00    | -8.47  | AV            |

| Polar (H/V)                     | Frequency | Meter Reading | Pre-amplifier | Cable Loss | Antenna Factor | Emission Level | Limits   | Margin | Detector Type |
|---------------------------------|-----------|---------------|---------------|------------|----------------|----------------|----------|--------|---------------|
|                                 | (MHz)     | (dBuV)        | (dB)          | (dB)       | (dB/m)         | (dBuV/m)       | (dBuV/m) | (dB)   |               |
| <b>operation frequency:2480</b> |           |               |               |            |                |                |          |        |               |
| V                               | 2483.50   | 67.68         | 38.17         | 7.42       | 20.51          | 57.44          | 74.00    | -16.56 | PK            |
| V                               | 2483.50   | 56.29         | 38.17         | 7.42       | 20.51          | 46.05          | 54.00    | -7.95  | AV            |
| V                               | 2500.00   | 67.61         | 38.20         | 7.45       | 20.54          | 57.40          | 74.00    | -16.60 | PK            |
| V                               | 2500.00   | 55.73         | 38.20         | 7.45       | 20.54          | 45.52          | 54.00    | -8.48  | AV            |
| H                               | 2483.50   | 67.80         | 38.17         | 7.42       | 20.51          | 57.56          | 74.00    | -16.44 | PK            |
| H                               | 2483.50   | 56.33         | 38.17         | 7.42       | 20.51          | 46.09          | 54.00    | -7.91  | AV            |
| H                               | 2500.00   | 67.41         | 38.20         | 7.45       | 20.54          | 57.20          | 74.00    | -16.80 | PK            |
| H                               | 2500.00   | 56.58         | 38.20         | 7.45       | 20.54          | 46.37          | 54.00    | -7.63  | AV            |

**Remark:**

1. Emission Level = Meter Reading + Factor, Margin= Emission Level - Limit
2. If peak below the average limit, the average emission was no test.
3. The amplitude of spurious emissions which are attenuated by more than 20dB below the permissible value has no need to be reported.



#### 4. BANDWIDTH TEST

##### 4.1 APPLIED PROCEDURES / LIMIT

| FCC Part15 (15.249) , |           |
|-----------------------|-----------|
| Section               | Test Item |
| 15.249                | Bandwidth |

##### 4.1.1 TEST PROCEDURE

1. Set RBW = 30 kHz.
2. Set the video bandwidth (VBW)  $\geq 3 \times$  RBW.
3. Detector = Peak.
4. Trace mode = max hold.
5. Sweep = auto couple.
6. Allow the trace to stabilize.
7. Measure the maximum width of the emission that is constrained by the frequencies associated with the two outermost amplitude points (upper and lower frequencies) that are attenuated by 6 dB relative to the maximum level measured in the fundamental emission.

##### 4.1.2 DEVIATION FROM STANDARD

No deviation.

##### 4.1.3 TEST SETUP

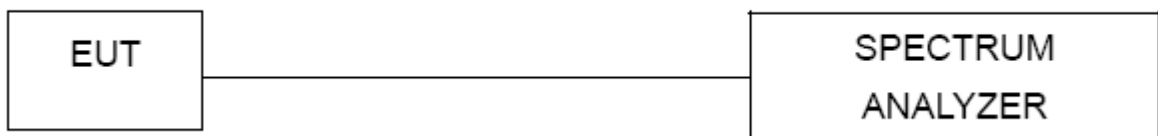

##### 4.1.4 EUT OPERATION CONDITIONS

The EUT tested system was configured as the statements of 2.3 Unless otherwise a special operating condition is specified in the follows during the testing.



4.1.5 TEST RESULTS

|               |                           |                     |         |
|---------------|---------------------------|---------------------|---------|
| Temperature : | 25°C                      | Relative Humidity : | 60%     |
| Pressure :    | 1012 hPa                  | Test Voltage :      | DC 3.7V |
| Test Mode :   | TX Mode /CH01, CH39, CH79 |                     |         |

|           | Frequency (MHz) | 20dB bandwidth (MHz) | Result |
|-----------|-----------------|----------------------|--------|
| GFSK      | 2402            | 0.826                | Pass   |
|           | 2441            | 0.831                | Pass   |
|           | 2480            | 0.835                | Pass   |
| PI/4 DPSK | 2402            | 1.339                | Pass   |
|           | 2441            | 1.324                | Pass   |
|           | 2480            | 1.365                | Pass   |
| 8DPSK     | 2402            | 1.356                | Pass   |
|           | 2441            | 1.326                | Pass   |
|           | 2480            | 1.205                | Pass   |

GFSK

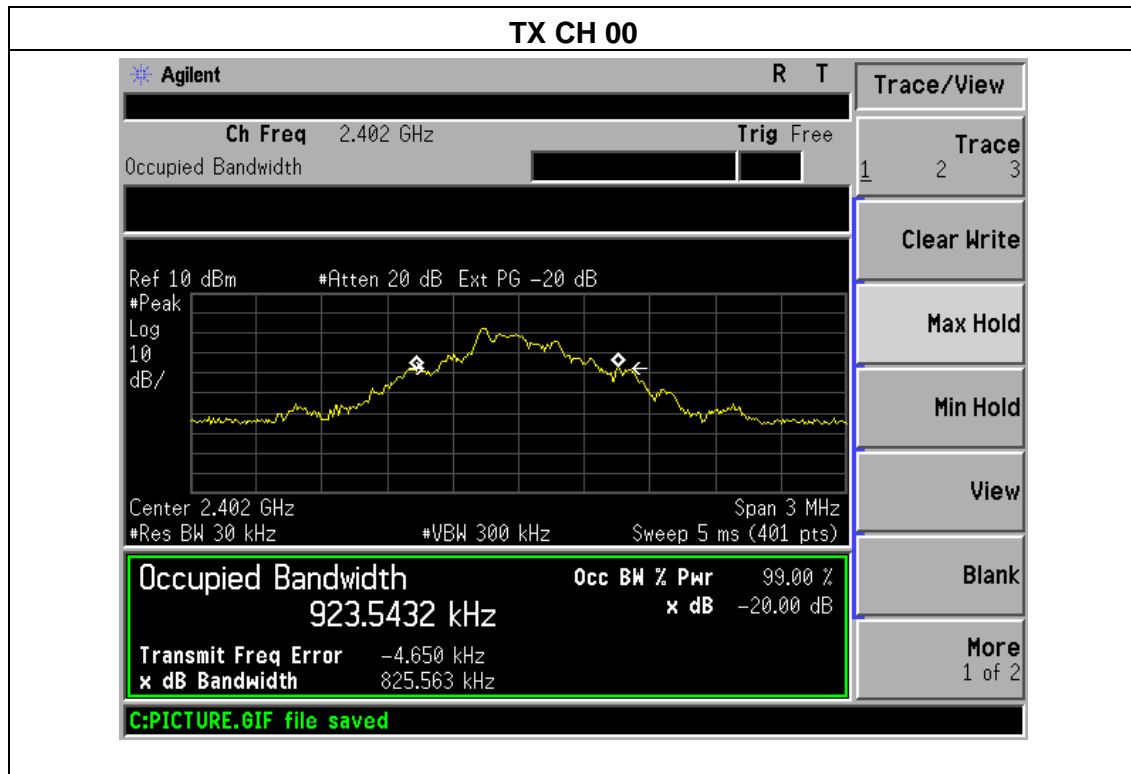

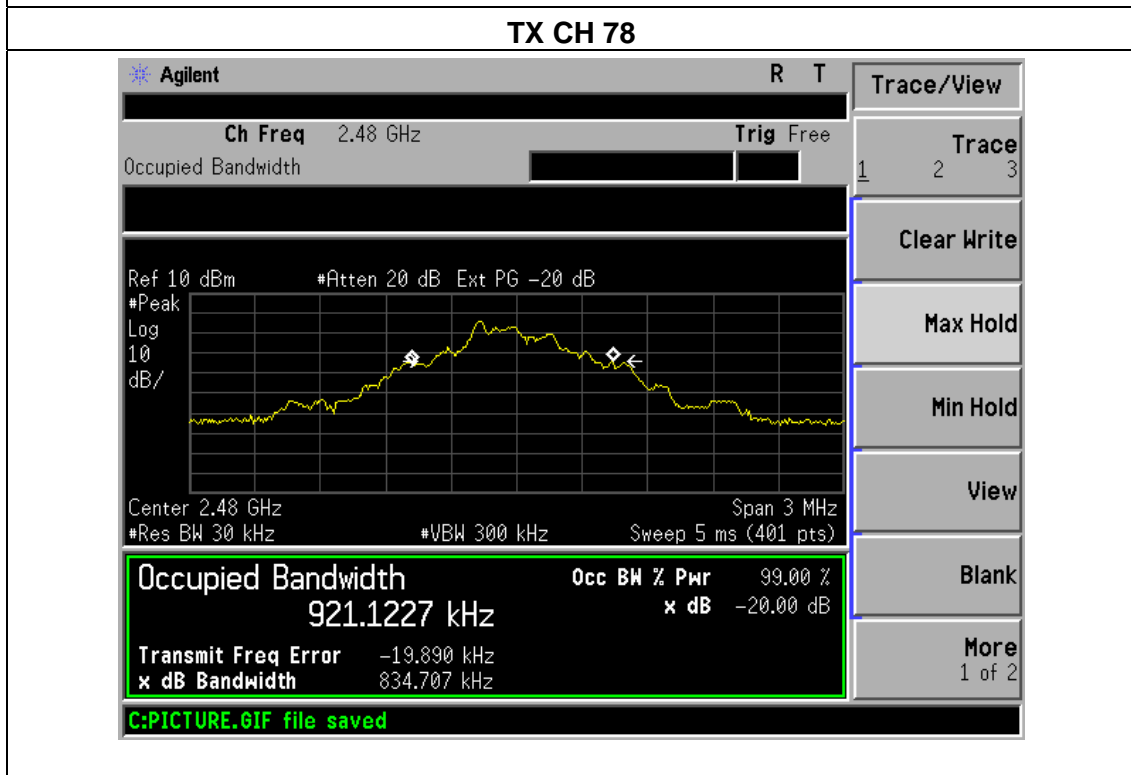
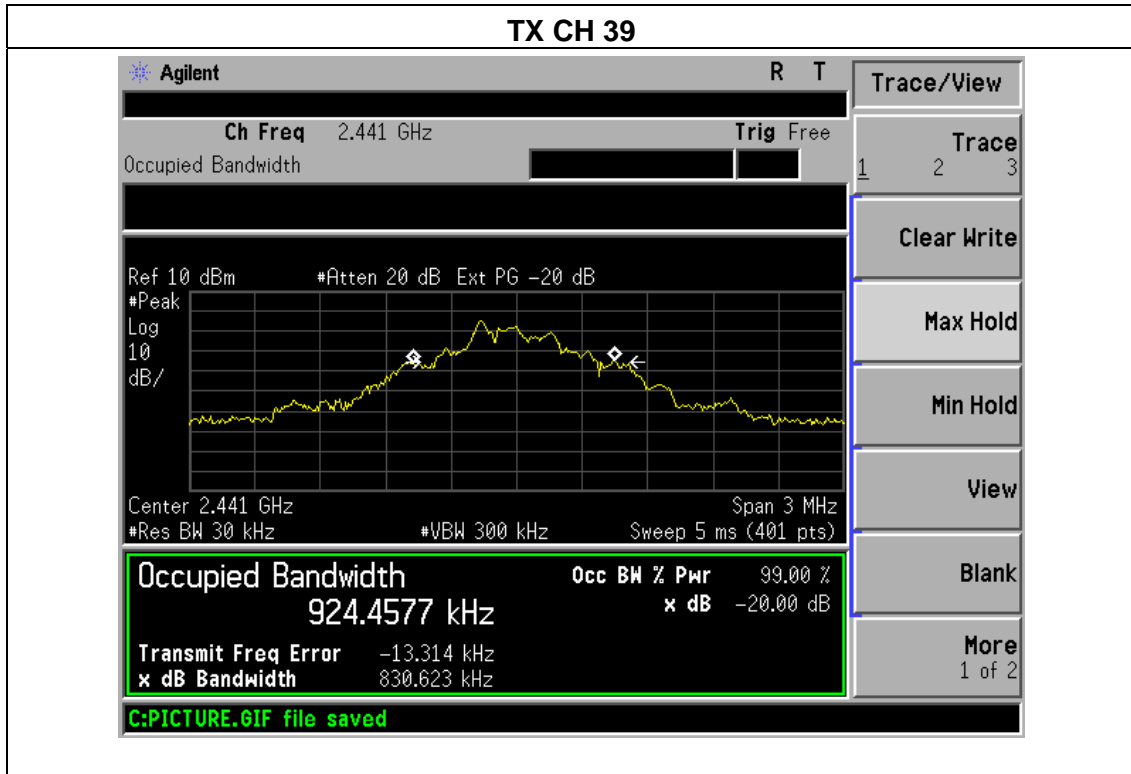



PI/4 DPSK

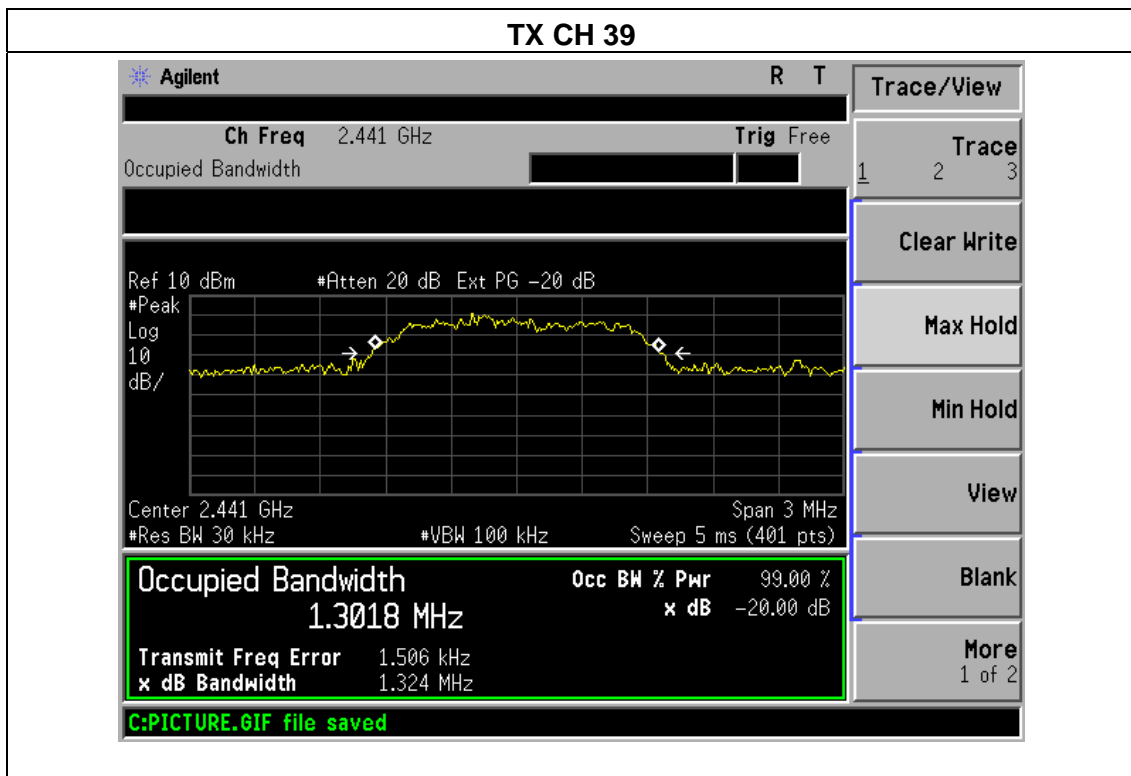
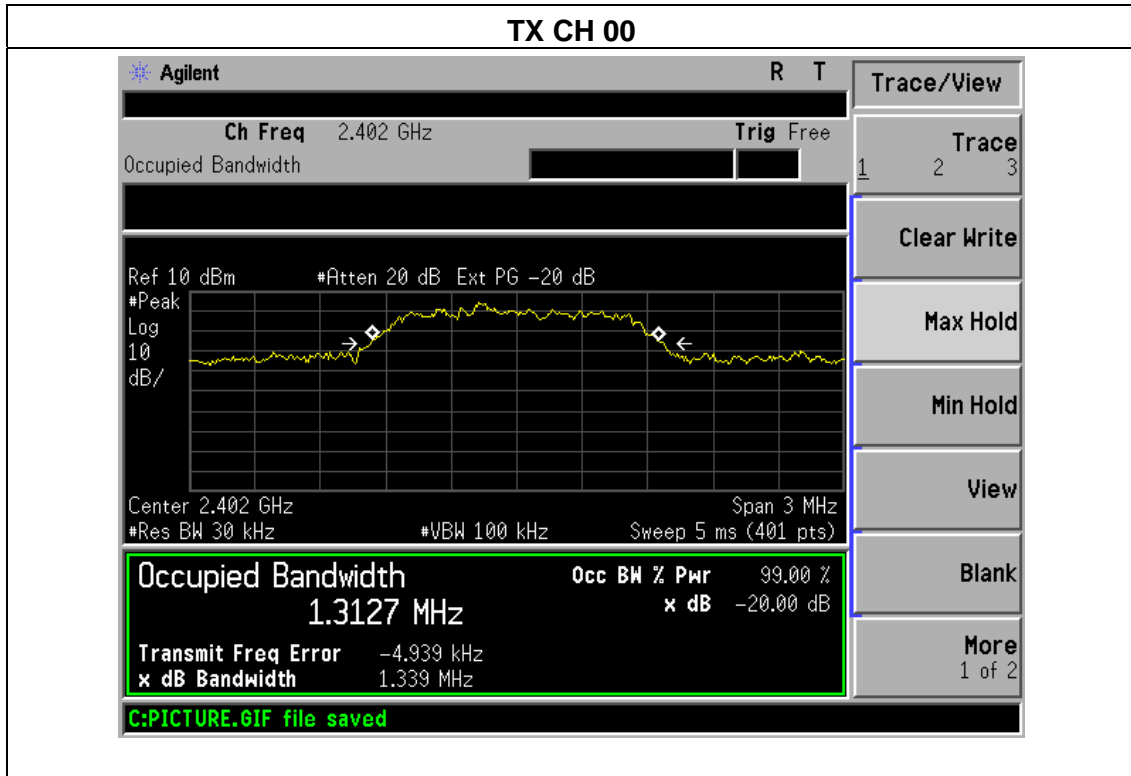

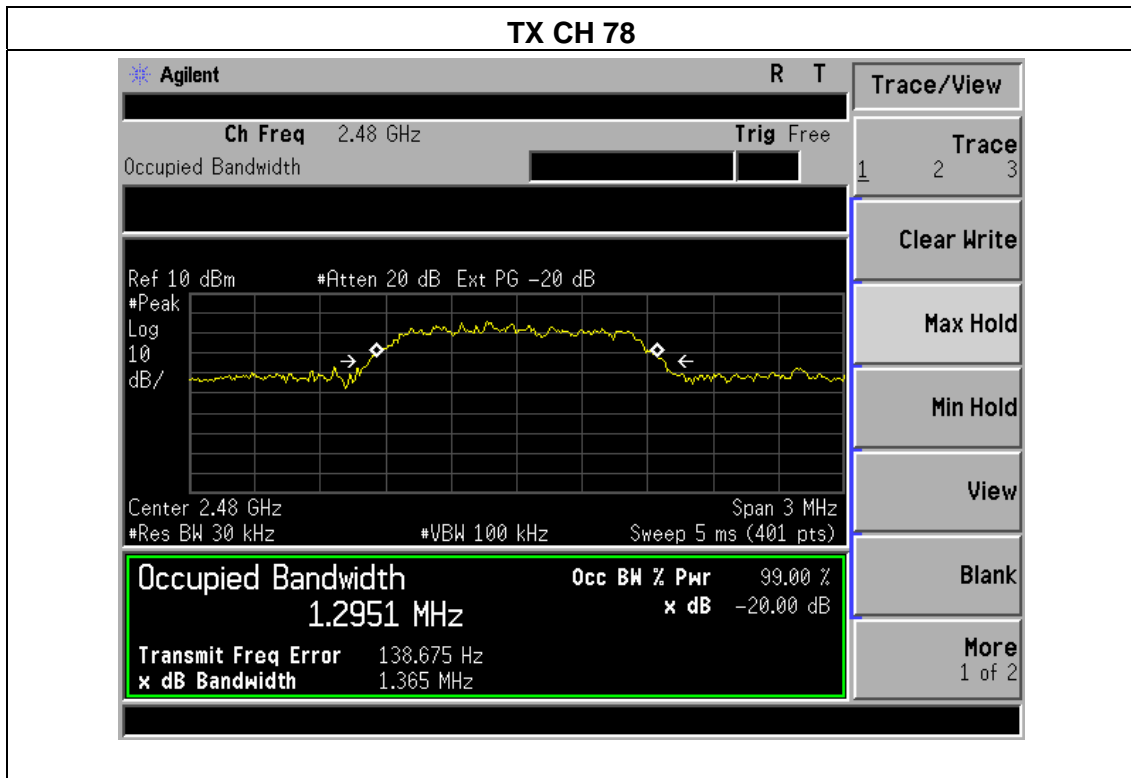

8DPSK

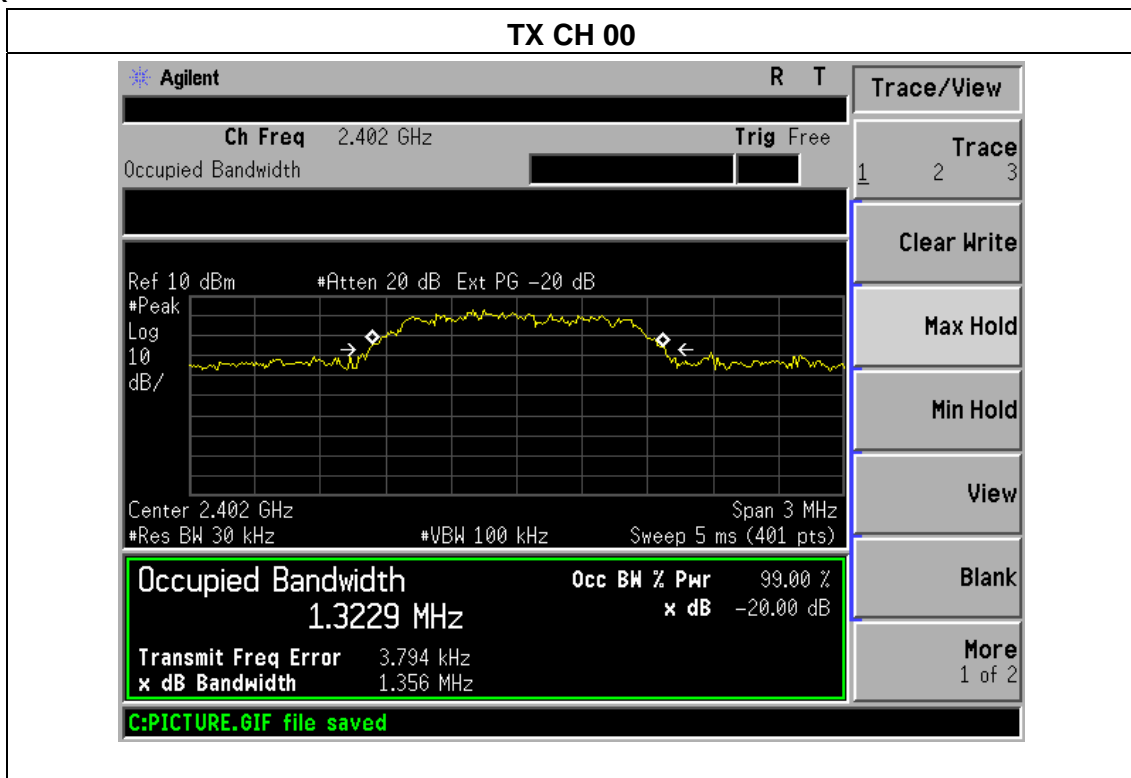



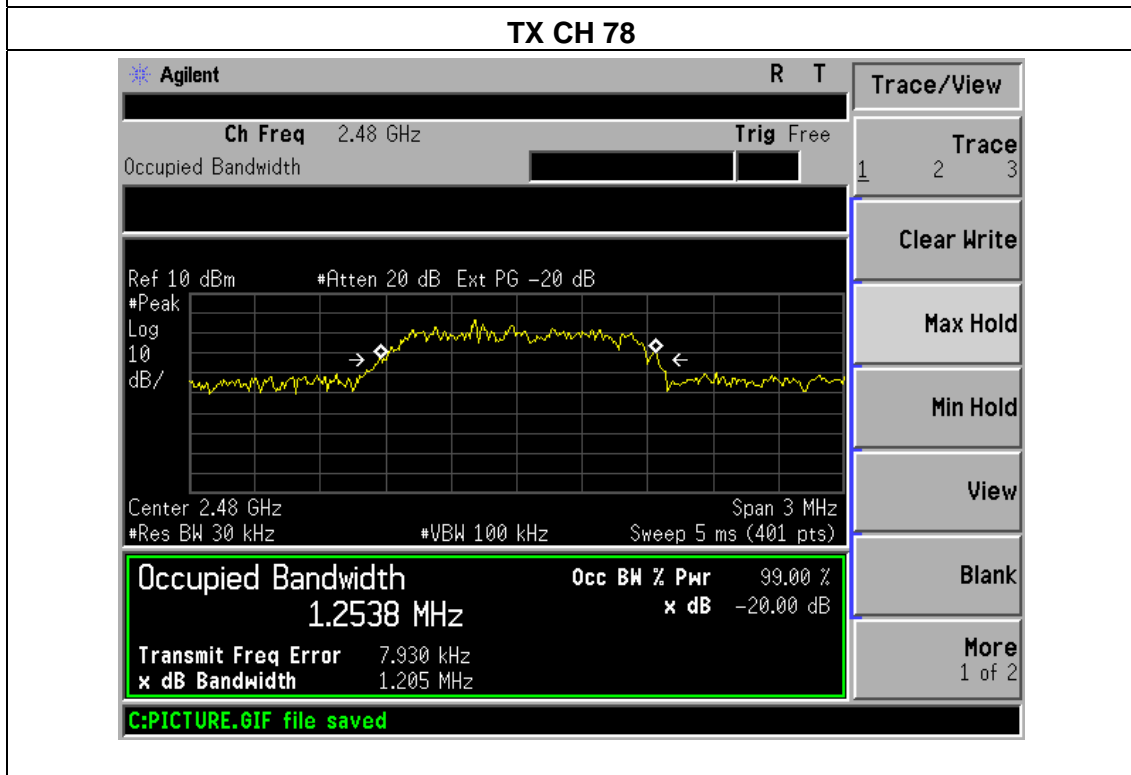
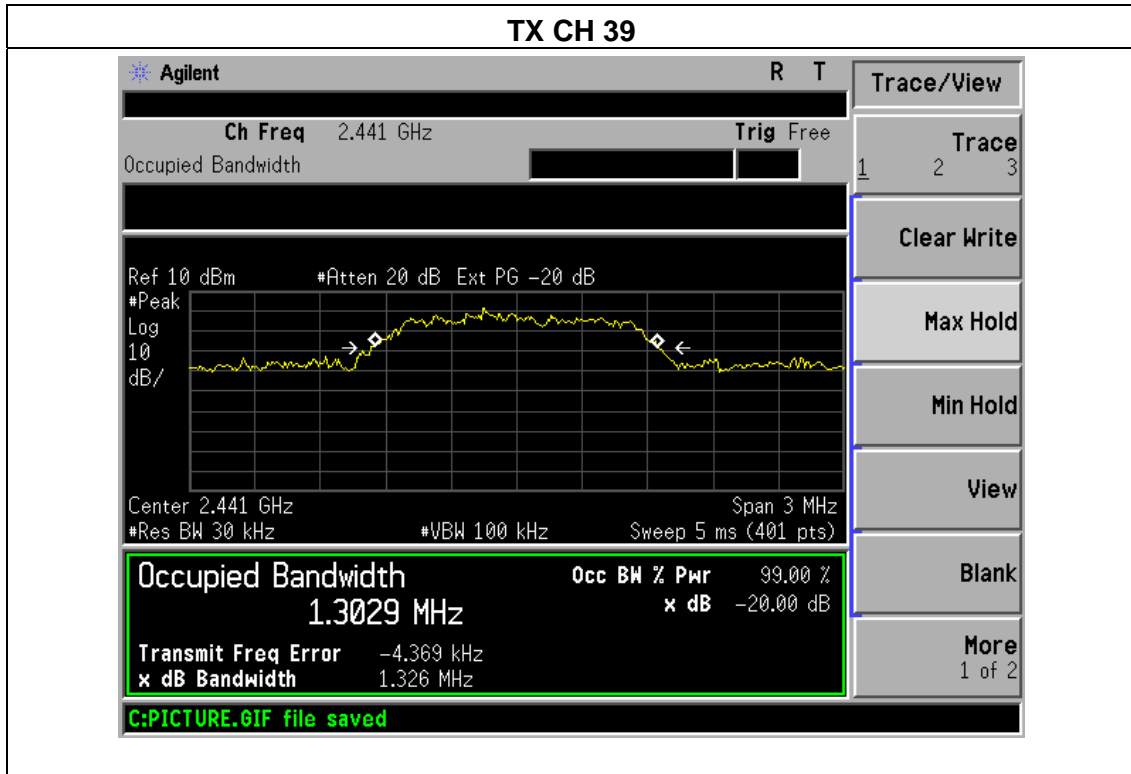



## **5. ANTENNA REQUIREMENT**

### **5.1 STANDARD REQUIREMENT**

15.203 requirement: For intentional device, according to 15.203: an intentional radiator shall be designed to ensure that no antenna other than that furnished by the responsible party shall be used with the device.

### **5.2 EUT ANTENNA**

The EUT antenna is internal PCB antenna,. It comply with the standard requirement.

## 6. TEST SEUUP PHOTO

### Radiated Measurement Photos

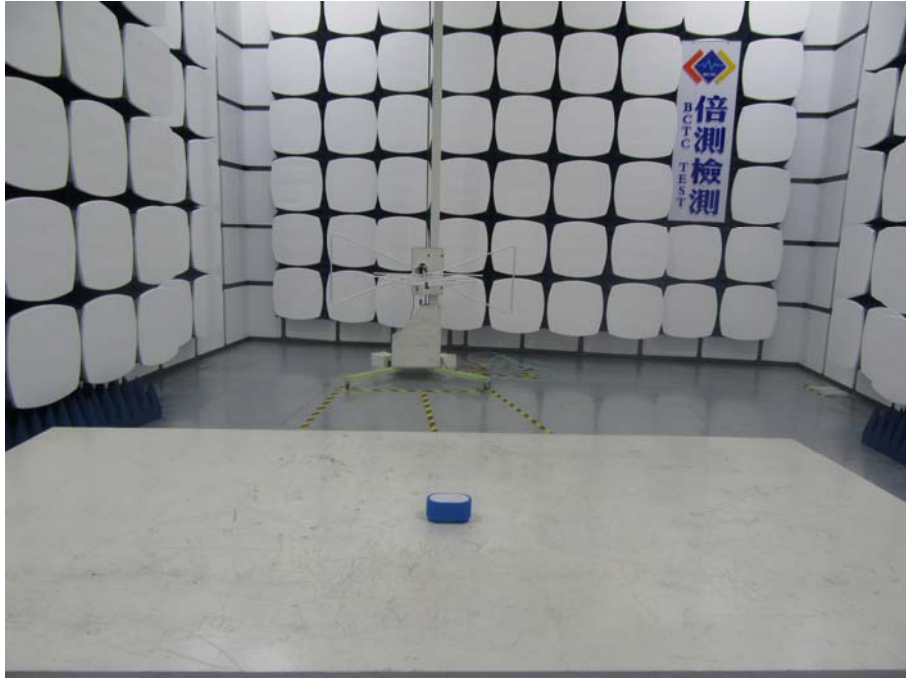

### Conducted Measurement Photos



## 7. EUT PHOTO

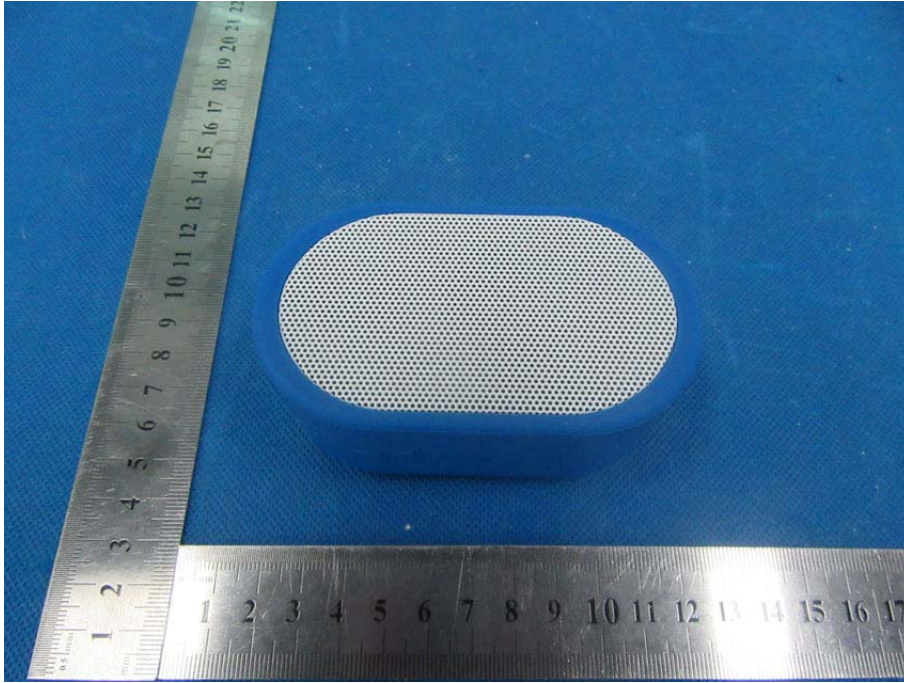

\*\*\*\*\* END OF REPORT \*\*\*\*\*