



FCC TEST REPORT

According to

CFR47 §15.407

Applicant : Guangzhou Shirui Electronics Co.,Ltd.
Address : 192 Kezhu Road, Sciencetech Park, Guangzhou Economic & Technology
 Development District, Guangzhou,Guangdong,China
Manufacturer : Guangzhou Shirui Electronics Co.,Ltd.
Address : 192 Kezhu Road, Sciencetech Park, Guangzhou Economic & Technology
 Development District, Guangzhou,Guangdong,China
Equipment : WiFi/BT Module
Model No. : WF-R22C-USA1
Brand : seewo
FCC ID : 2AFG6-WF-R22C-USA1
Test Period : Jul. 04, 2019~ Jul. 25, 2019

- The test result refers exclusively to the test presented test model / sample.
- Without written approval of **CerpPASS Technology (Suzhou) Co., Ltd.**, the test report shall not be reproduced exc- ept in full.
- The test report must not be used by the clients to claim product certification approval by any agency of the Government.

I **HEREBY** CERTIFY THAT :

The measurements shown in this test report were made in accordance with the procedures given in **ANSI C63.10 – 2013& FCC Part15.407** and the energy emitted by this equipment was **passed**.

Approved by:



 Miro Chueh
 EMC/RF Manager

Laboratory Accreditation:

CerpPASS Technology Corporation Test Laboratory

TAF LAB Code: 1439

CerpPASS Technology (SuZhou) Co., Ltd.

A2LA LAB Code: 4981.01



CONTENTS

- 1. Summary of Test Procedure and Test Results5
 - 1.1. Applicable Standards5
- 2. Test Configuration of Equipment under Test6
 - 2.1. Feature of Equipment under Test.....6
 - 2.2. Carrier Frequency of Channels7
 - 2.3. Test Mode and Test Software8
 - 2.4. Description of Test System.....8
 - 2.5. General Information of Test.....9
 - 2.6. Measurement Uncertainty10
- 3. Test Equipment and Ancillaries Used for Tests11
- 4. Antenna Requirements.....12
 - 4.1. Standard Applicable12
 - 4.2. Antenna Construction and Directional Gain.....12
- 5. Test of AC Power Line Conducted Emission13
 - 5.1. Test Limit13
 - 5.2. Test Procedures13
 - 5.3. Typical Test Setup14
 - 5.4. Test Result and Data15
- 6. Test of Spurious Emission (Radiated)23
 - 6.1. Test Limit23
 - 6.2. Test Procedures23
 - 6.3. Typical Test Setup24
 - 6.4. Test Result and Data (9kHz ~ 30MHz).....25
 - 6.5. Test Result and Data (30MHz ~ 1GHz).....25
 - 6.6. Test Result and Data (1GHz ~ 40GHz).....29
 - 6.7. Restricted Bands of Operation67
- 7. On Time, Duty Cycle and Measurement methods68
 - 7.1. Test Limit68
 - 7.2. Test Procedure68
 - 7.3. Test Setup Layout68
 - 7.4. Test Result and Data68
 - 7.5. Measurement Methods68
- 8. 6dB Bandwidth & 99% Bandwidth.....70
 - 8.1. Test Limit70
 - 8.2. Test Procedure70
 - 8.3. Test Setup Layout70
 - 8.4. Test Result and Data (6dB Bandwidth)71
 - 8.5. Test Result and Data (99% Bandwidth)72
- 9. 26dB Bandwidth & 99% Bandwidth.....79
 - 9.1. Test Limit79
 - 9.2. Test Procedure79
 - 9.3. Test Setup Layout79
 - 9.4. Test Result and Data79
- 10. Average Power91



- 10.1. Test Limit 91
- 10.2. Test Procedure 92
- 10.3. Test Setup Layout 92
- 10.4. Test Result and Data 93
- 11. PPSD 95
 - 11.1. Test Limit 95
 - 11.2. Test Procedure 95
 - 11.3. Test Setup Layout 95
 - 11.4. Test Result and Data 96
- 12. Frequency Stability 111
 - 12.1. Test Procedure 111
 - 12.2. Test Setup Layout 111
 - 12.3. Test Result and Data 112
- 13. Automatically Discontinue Transmission 113
 - 13.1. Limit of Automatically Discontinue Transmission 113
 - 13.2. Test Result of Automatically Discontinue Transmission 113
- 14. Dynamic Frequency Selection 114
 - 14.1. List of Measurement and Examinations 114
 - 14.2. Test Setup 116
 - 14.3. Non-Occupancy Period 118
 - 14.4. DFS Detection Threshold 121
 - 14.5. Channel Availability Check 122
 - 14.6. U-NII Detection Bandwidth 123
 - 14.7. Uniform Spreading 124
 - 14.8. In-Service Monitoring 125
 - 14.9. Statistical Performance Check 126
 - 14.10. EUT Setup Photos 127



1. Summary of Test Procedure and Test Results

1.1. Applicable Standards

ANSI C63.4:2014

ANSI C63.10:2013

FCC Rules and Regulations Part 15 Subpart E §15.407

First R&O 14-30

KDB662911

KDB789033

KDB644545

FCC Rule	Description of Test	Result
15.203	Antenna Requirement	Pass
15.207(a)	AC Power Line Conducted Emission	Pass
15.407(b) 15.209	Radiated Spurious Emission	Pass
15.407(a)	26 dB Occupied Bandwidth	Pass
15.407	6 dB Bandwidth	Pass
15.407 (a) & (a)(3)	Average Power	Pass
15.407(a)	Output and PPSD	Pass
15.407(g)	Frequency Stability	Pass
15.407(c)	Automatically Discontinue Transmission	Pass
2.1091	Radio Frequency Exposure	Pass



2. Test Configuration of Equipment under Test

2.1. Feature of Equipment under Test

Equipment	WiFi/BT Module
Model No.	WF-R22C-USA1
Model Discrepancy	N/A
IEEE Standards	IEEE 802.11a/b/g/n/ac
Operating Frequencies	5.15~5.85GHz
Modulation	802.11b: CCK, DQPSK, DBPSK 802.11a/g: 64-QAM,16-QAM, QPSK, BPSK 802.11n: 64-QAM,16-QAM, QPSK, BPSK 802.11ac: 256-QAM,64-QAM,16-QAM, QPSK, BPSK
Wireless Data Rate	802.11b: 1, 2 ,5.5,11Mbps 802.11a/g: 6,9,12,18,24,36,48,54Mbps 802.11n: HT20 reach up to144.4Mbps, HT40 reach up to300Mbps 802.11ac: VHT20 reach up to173.3Mbps, VHT40 reach up to400Mbps, VHT80 reach up to866.7Mbps

Note: For a more detailed features description, please refer to the manufacturer’s specifications or the User’s Manual.



2.2. Carrier Frequency of Channels

Band 1: 5150MHz-5250MHz

802.11a, 802.11n HT20, 802.11ac VHT20

Channel	Frequency(MHz)	Channel	Frequency(MHz)
*36	5180	*44	5220
40	5200	*48	5240

802.11n HT40, 802.11ac VHT40

Channel	Frequency(MHz)	Channel	Frequency(MHz)
*38	5190	*46	5230

802.11ac VHT80

Channel	Frequency(MHz)
*42	5210

Band 2: 5250MHz -5350MHz

802.11a, 802.11n HT20, 802.11ac VHT20

Channel	Frequency(MHz)	Channel	Frequency(MHz)
*52	5260	*60	5300
56	5280	*64	5320

802.11n HT40, 802.11ac VHT40

Channel	Frequency(MHz)	Channel	Frequency(MHz)
*54	5270	*62	5310

802.11ac VHT80

Channel	Frequency(MHz)
*58	5290

Band 3: 5470MHz -5725MHz

802.11a, 802.11n HT20, 802.11ac VHT20

Channel	Frequency(MHz)	Channel	Frequency(MHz)
*100	5500	124	5620
104	5520	128	5640
108	5540	132	5660
112	5560	136	5680
*116	5580	*140	5700
120	5600		

802.11n HT40, 802.11ac VHT40

Channel	Frequency(MHz)	Channel	Frequency(MHz)
*102	5510	126	5630
*110	5550	*134	5670
118	5590		

802.11ac VHT80

Channel	Frequency(MHz)	Channel	Frequency(MHz)
*106	5530	*122	5610

Band 4: 5725MHz -5850MHz

802.11a, 802.11n HT20, 802.11ac VHT20

Channel	Frequency(MHz)	Channel	Frequency(MHz)
*149	5745	161	5805
153	5765	*165	5825
*157	5785		

802.11n HT40, 802.11ac VHT40

Channel	Frequency(MHz)	Channel	Frequency(MHz)
*151	5755	*159	5795

802.11ac VHT80

Channel	Frequency(MHz)
*155	5775

Note: Channels remarked * are selected to perform test.



2.3. Test Mode and Test Software

- a. During testing, the interface cables and equipment positions were varied according to ANSI C63.4.
- b. The complete test system included remote workstation and EUT for RF test. The remote workstation included Notebook.
An executive program, "REALTEK 11ac 8812AU USB WLAN NIC Massproduction Kit" under WIN 7 was executed to transmit and receive data via WLAN.
- c. The following test modes were performed for the test:

Conducted Emissions from the AC mains power ports	
Test Mode	Operating Description
1	802.11a (6Mbps)
2	802.11ac VHT20 (6.5Mbps)
3	802.11ac VHT40 (13.5Mbps)
4	802.11ac VHT80 (29.3Mbps)
caused "Test Mode 1" generated the worst case, it was reported as the final data.	
Radiation Emissions (30MHz ~ 1GHz)	
Test Mode	Operating Description
1	802.11a (6Mbps)
2	802.11ac VHT20 (6.5Mbps)
3	802.11ac VHT40 (13.5Mbps)
4	802.11ac VHT80 (29.3Mbps)
caused "Test Mode 1" generated the worst case, they were reported as the final data.	
Radiation Emissions (1GHz ~ 40GHz)	
Test Mode	Operating Description
1	802.11a (6Mbps)
2	802.11ac VHT20 (6.5Mbps)
3	802.11ac VHT40 (13.5Mbps)
4	802.11ac VHT80 (29.3Mbps)
caused "Test Mode 1~4" generated the worst case, they were reported as the final data.	

2.4. Description of Test System

Device	Manufacturer	Model No.	Description
Notebook	SONY	PCG-71811P	Power Cable, Unshielding, 1.7m



2.5. General Information of Test

<input type="checkbox"/>	Test Site	<p>CerpPASS Technology Corporation Test Laboratory Address: No.10, Ln. 2, Lianfu St., Luzhu Dist., Taoyuan City 33848, Taiwan (R.O.C.) Tel:+886-3-3226-888 Fax:+886-3-3226-881 Address: No.68-1, Shihbachongsi, Shihding Township, New Taipei City 223, Taiwan, R.O.C. Tel: +886-2-2663-8582</p>
	TAF	1439
	FCC	TW1079, TW1061
	IC	4934E-1, 4934E-2
	VCCI	T-2205 for Telecommunication Test C-4663 for Conducted emission test R-4399, R-4218 for Radiated emission test G-812, G-813 for radiated disturbance above 1GHz
<input checked="" type="checkbox"/>	Test Site	<p>CerpPASS Technology (Suzhou) Co.,Ltd Address: No.66,Tangzhuang Road, Suzhou Industrial Park, Jiangsu 215006, China Tel: +86-512-6917-5888 Fax: +86-512-6917-5666</p>
	CNAS	L5515
	FCC	CN1243
	A2LA	4981.01
	IC	7290A-1, 7290A-2
VCCI	T-1945 for Telecommunication Test C-2919 for Conducted emission test R-2670 for Radiated emission test G-227 for radiated disturbance above 1GHz	



2.6. Measurement Uncertainty

ISO/IEC 17025 requires that an estimate of the measurement uncertainties associated with the emissions test results be included in the report. The measurement uncertainties given below are based on a 95% confidence level (based on a coverage factor (k=2)).

RF Conducted Measurement

Test Item	Uncertainty	Limit
Radio Frequency	$\pm 8.7 \times 10^{-7}$	$\pm 1 \times 10^{-5}$
RF output power, conducted	$\pm 0.63 \text{dB}$	$\pm 1.5 \text{dB}$
Power density, conducted	$\pm 1.21 \text{dB}$	$\pm 3 \text{dB}$
Unwanted emissions, conducted	30-1000MHz	$\pm 0.51 \text{dB}$
	1-25GHz	$\pm 0.67 \text{dB}$
All emissions, radiated	30-1000MHz	$\pm 2.28 \text{dB}$
	1-25GHz	$\pm 2.59 \text{dB}$
Temperature	$\pm 0.8^\circ\text{C}$	$\pm 1^\circ\text{C}$
Humidity	$\pm 3\%$	$\pm 5\%$
DC and low frequency voltages	$\pm 3\%$	$\pm 3\%$

AC Conducted Measurement

Measurement	Frequency	Uncertainty
Conducted emissions(LINE)	9KHz-30MHz	+/- 0.7738 dB
Conducted emissions(NEUTRAL)	9KHz-30MHz	+/- 0.7886 dB
Conducted emissions(10Mbps)	150KHz-30MHz	+/- 1.3013dB
Conducted emissions(100Mbps)	150KHz-30MHz	+/- 1.3197 dB
Conducted emissions(1000Mbps)	150KHz-30MHz	+/- 1.2987 dB

Radiated Measurement

Measurement	Polarity	Frequency	Uncertainty
Radiated emissions	Horizontal	below 1GHz	+/- 3.8936 dB
	Vertical	below 1GHz	+/- 3.8928 dB
	Horizontal	above 1GHz	+/- 5.18858dB
	Vertical	above 1GHz	+/- 5.18928 dB



3. Test Equipment and Ancillaries Used for Tests

Instrument/Ancillary	Manufacturer	Model No.	Serial No.	Calibration Date	Valid Date.
EMI Receiver	R&S	ESCI3	100563	2019.06.21	2020.06.20
LISN	Schwarzbeck	NSLK 8127	8127-920	2018.09.25	2019.09.24
Pulse Limiter	R&S	ESH3-Z2	100529	2019.03.11	2020.03.10
Software	Farad	Ez-EMC	ver.ct3a1	N/A	N/A

Instrument/Ancillary	Manufacturer	Model No.	Serial No.	Calibration Date	Valid Date.
Bilog Antenna	Sunol	JB1	A072414-2 -2	2019.07.13	2020.07.13
EMI Receiver	R&S	ESCI3	101183	2019.06.28	2020.06.27
EMI Receiver	R&S	ESCI7	100968	2018.07.30	2019.07.29
Preamplifier	EM Electronics corp.	EM330	60618	2019.03.11	2020.03.10
Horn Antenna	Schwarzbeck	BBHA9120 D	9120D-619	2019.07.13	2020.07.13
Horn Antenna	Schwarzbeck	BBHA9170	9170-348	2019.06.23	2020.06.22
Spectrum Analyzer	R&S	FSP40	100324	2019.07.13	2020.07.12
Preamplifier	EMCI	EMCI 030-00-3230	SN016723	2019.03.11	2020.03.10
Preamplifier	EM Electronics corp.	EM01G18G	SN060714	2019.03.23	2020.03.22
Spectrum Analyzer	KEYSIGHT	N9010A	MY53400169	2018.08.25	2019.08.24
Software	E3	AUDIX	Version: 8.14.806b	N/A	N/A



4. Antenna Requirements

4.1. Standard Applicable

For intentional device, according to FCC 47 CFR Section 15.203, an intentional radiator shall be designed to ensure that no antenna other than that furnished by the responsible party shall be used with the device.

And according to FCC 47 CFR Section 15.407 (a), if transmitting antennas of directional gain greater than 6dBi are used, the power shall be reduced by the amount in dB that the directional gain of the antenna exceeds 6dBi.

4.2. Antenna Construction and Directional Gain

Antenna Type	Dipole Antenna
Antenna Gain	2400MHz-2500MHz: Chain 1: 3.18dBi ; Chain 2: 3.18dBi 5150MHz-5250MHz: Chain 1: 3.53dBi ; Chain 2: 3.53dBi 5250MHz-5350MHz: Chain 1: 3.53dBi ; Chain 2: 3.53dBi 5470MHz-5725MHz: Chain 1: 3.24dBi ; Chain 2: 3.24dBi 5725MHz-5850MHz: Chain 1: 4.36dBi ; Chain 2: 4.36dBi

2412-2462MHz
For Power directional gain= $G_{ant}=3.18\text{dBi}$ For PSD directional gain = $10 \log[(10^{G1/20} + 10^{G2/20})^2 / N_{ANT}]$ = 6.19 (dBi)
5150MHz -5250MHz
For Power directional gain= $G_{ant}= 3.53\text{dBi}$ For PSD directional gain = $10 \log[(10^{G1/20} + 10^{G2/20})^2 / N_{ANT}]$ =6.54(dBi)
5250MHz -5350MHz
For Power directional gain= $G_{ant}= 3.53\text{dBi}$ For PSD directional gain = $10 \log[(10^{G1/20} + 10^{G2/20})^2 / N_{ANT}]$ =6.54(dBi)
5470MHz -5725MHz
For Power directional gain= $G_{ant}= 3.24\text{dBi}$ For PSD directional gain = $10 \log[(10^{G1/20} + 10^{G2/20})^2 / N_{ANT}]$ =6.25(dBi)
5725MHz -5850MHz
For Power directional gain= $G_{ant}= 4.36\text{dBi}$ For PSD directional gain = $10 \log[(10^{G1/20} + 10^{G2/20})^2 / N_{ANT}]$ = 7.37(dBi)



5. Test of AC Power Line Conducted Emission

5.1. Test Limit

Conducted Emissions were measured from 150 kHz to 30 MHz with a bandwidth of 9 KHz, according to the methods defined in ANSI C63.4-2014. The EUT was placed on a nonmetallic stand in a shielded room 0.8 meters above the ground plane. The interface cables and equipment positioning were varied within limits of reasonable applications to determine the position produced maximum conducted emissions.

Frequency (MHz)	Quasi Peak (dB μ V)	Average (dB μ V)
0.15 – 0.5	66-56*	56-46*
0.5 – 5.0	56	46
5.0 – 30.0	60	50

*Decreases with the logarithm of the frequency.

5.2. Test Procedures

- The EUT was placed 0.4 meter from the conducting wall of the shielding room was kept at least 80 centimeters from any other grounded conducting surface.
- Connect EUT to the power mains through a line impedance stabilization network (LISN).
- All the support units are connecting to the other LISN.
- The LISN provides 50 ohm coupling impedance for the measuring instrument.
- The FCC states that a 50 ohm, 50 micro-Henry LISN should be used.
- Both sides of AC line were checked for maximum conducted interference.
- The frequency range from 150 kHz to 30 MHz was searched.
- Set the test-receiver system to Peak Detect Function and Specified Bandwidth with Maximum Hold Mode.



5.3. Typical Test Setup

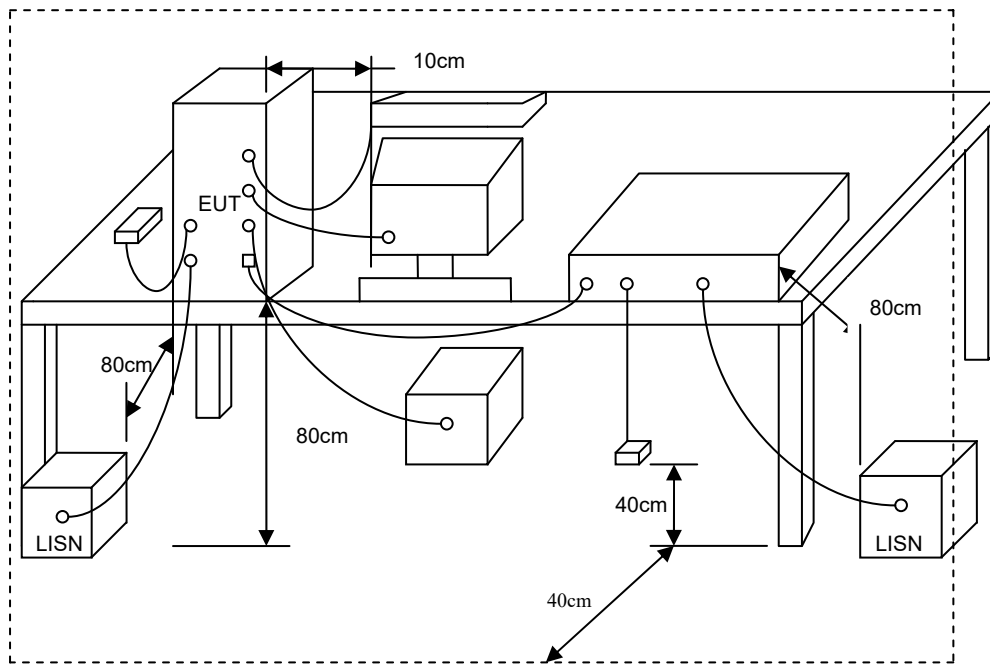



5.4. Test Result and Data

Test Mode :	Mode 1, Band 1		
AC Power :	AC 120V/60Hz	Phase:	LINE
Temperature :	26°C	Humidity:	60%
Pressure(mbar) :	1002	Date:	2019-07-22

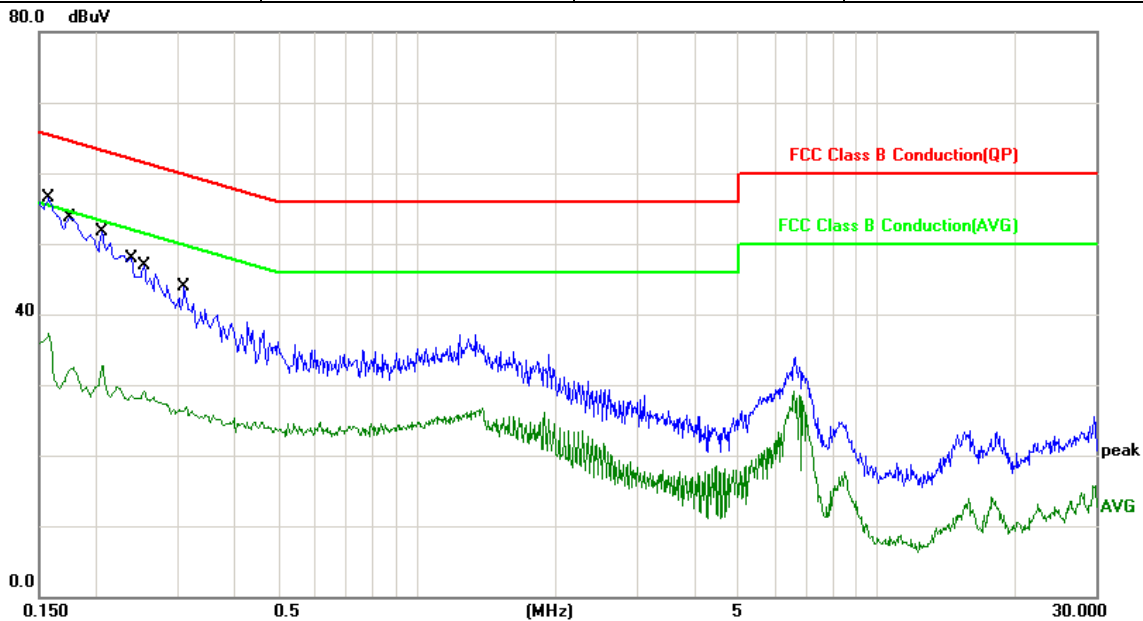

No.	Frequency (MHz)	Factor (dB)	Reading (dBuV)	Level (dBuV)	Limit (dBuV)	Margin (dB)	Detector
1	0.1580	10.06	37.46	47.52	65.56	-18.04	QP
2	0.1580	10.06	20.13	30.19	55.56	-25.37	AVG
3	0.1740	10.06	35.84	45.90	64.76	-18.86	QP
4	0.1740	10.06	22.42	32.48	54.76	-22.28	AVG
5	0.2060	10.06	31.89	41.95	63.36	-21.41	QP
6	0.2060	10.06	18.55	28.61	53.36	-24.75	AVG
7	0.2380	10.04	29.07	39.11	62.16	-23.05	QP
8	0.2380	10.04	17.84	27.88	52.16	-24.28	AVG
9	0.2540	10.03	27.88	37.91	61.62	-23.71	QP
10	0.2540	10.03	17.48	27.51	51.62	-24.11	AVG
11	0.3100	10.00	24.32	34.32	59.97	-25.65	QP
12	0.3100	10.00	16.52	26.52	49.97	-23.45	AVG

Note: Measurement Level = Reading Level + Correct Factor



Test Mode :	Mode 1, Band 1		
AC Power :	AC 120V/60Hz	Phase:	NEUTRAL
Temperature :	26°C	Humidity:	60%
Pressure(mbar) :	1002	Date:	2019-07-22

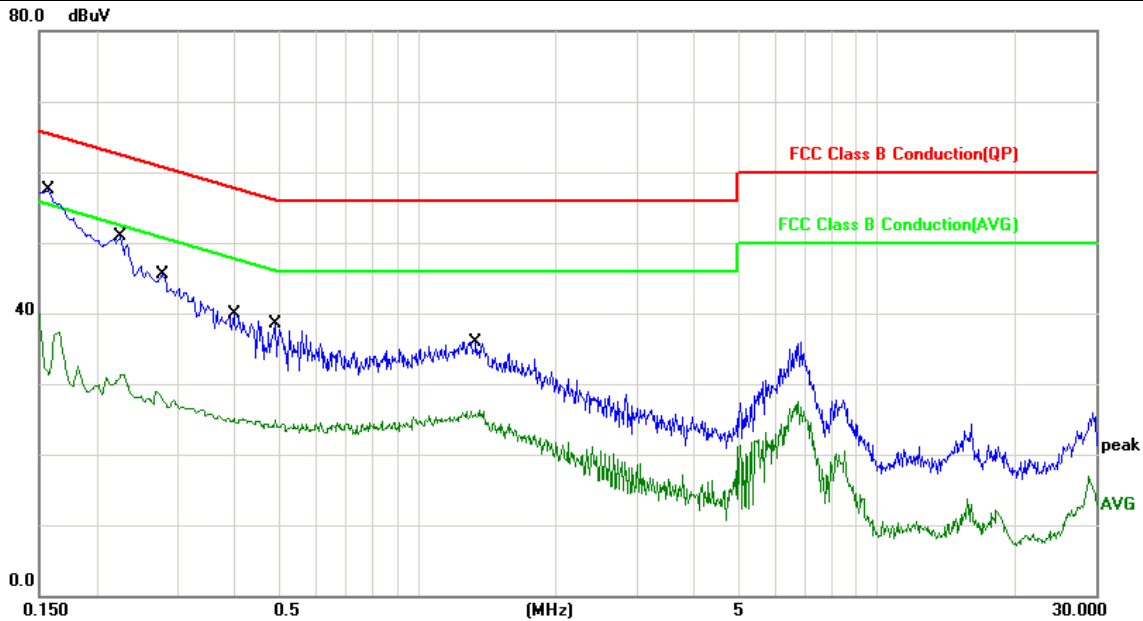

No.	Frequency (MHz)	Factor (dB)	Reading (dBuV)	Level (dBuV)	Limit (dBuV)	Margin (dB)	Detector
1	0.1580	10.06	38.81	48.87	65.56	-16.69	QP
2	0.1580	10.06	22.78	32.84	55.56	-22.72	AVG
3	0.2260	10.05	31.78	41.83	62.59	-20.76	QP
4	0.2260	10.05	18.75	28.80	52.59	-23.79	AVG
5	0.2779	10.02	27.57	37.59	60.88	-23.29	QP
6	0.2779	10.02	17.50	27.52	50.88	-23.36	AVG
7	0.3980	9.95	21.39	31.34	57.89	-26.55	QP
8	0.3980	9.95	14.65	24.60	47.89	-23.29	AVG
9	0.4900	9.90	24.57	34.47	56.17	-21.70	QP
10	0.4900	9.90	21.66	31.56	46.17	-14.61	AVG
11	1.3420	10.14	20.21	30.35	56.00	-25.65	QP
12	1.3420	10.14	15.14	25.28	46.00	-20.72	AVG



Test Mode :	Mode 1, Band 2		
AC Power :	AC 120V/60Hz	Phase:	LINE
Temperature :	26°C	Humidity:	60%
Pressure(mbar) :	1002	Date:	2019-07-22

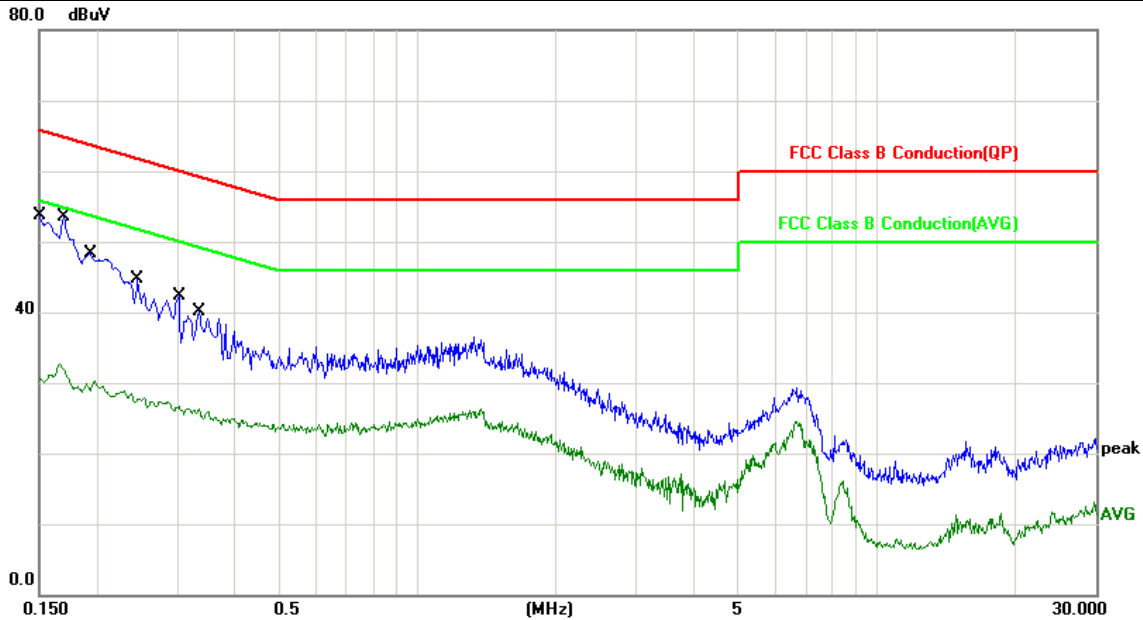

No.	Frequency (MHz)	Factor (dB)	Reading (dBuV)	Level (dBuV)	Limit (dBuV)	Margin (dB)	Detector
1	0.1500	10.06	36.00	46.06	65.99	-19.93	QP
2	0.1500	10.06	22.75	32.81	55.99	-23.18	AVG
3	0.1700	10.06	32.95	43.01	64.96	-21.95	QP
4	0.1700	10.06	19.58	29.64	54.96	-25.32	AVG
5	0.1940	10.06	30.30	40.36	63.86	-23.50	QP
6	0.1940	10.06	18.64	28.70	53.86	-25.16	AVG
7	0.2460	10.03	26.12	36.15	61.89	-25.74	QP
8	0.2460	10.03	17.77	27.80	51.89	-24.09	AVG
9	0.3020	10.00	22.74	32.74	60.19	-27.45	QP
10	0.3020	10.00	16.27	26.27	50.19	-23.92	AVG
11	0.3339	9.98	21.69	31.67	59.35	-27.68	QP
12	0.3339	9.98	15.64	25.62	49.35	-23.73	AVG

Note: Measurement Level = Reading Level + Correct Factor



Test Mode :	Mode 1, Band 2		
AC Power :	AC 120V/60Hz	Phase:	NEUTRAL
Temperature :	26°C	Humidity:	60%
Pressure(mbar) :	1002	Date:	2019-07-22

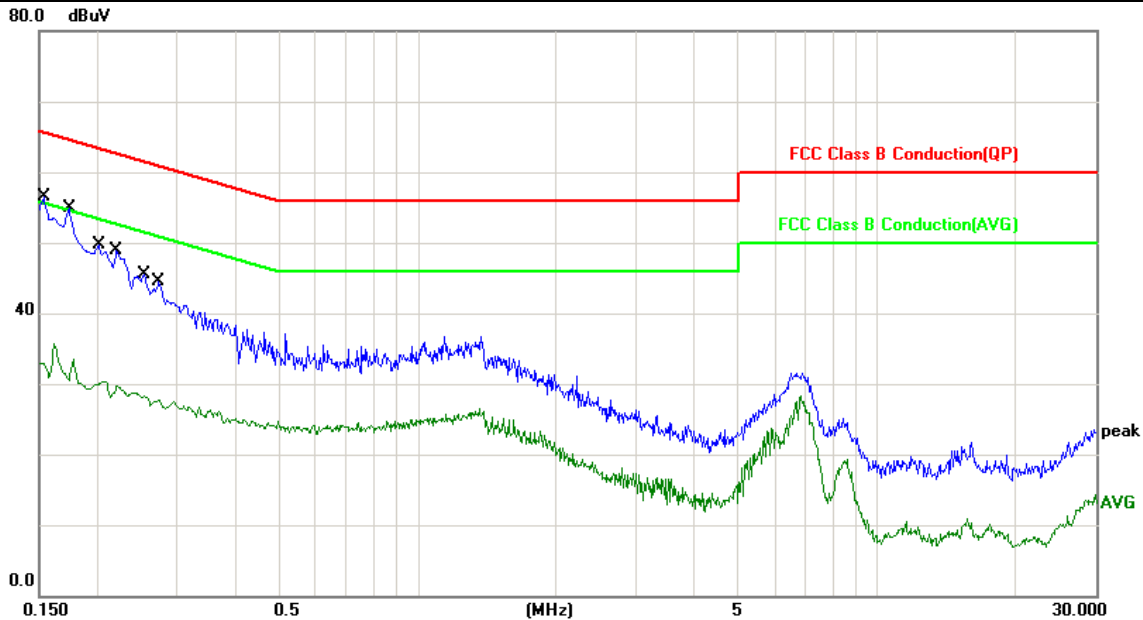

No.	Frequency (MHz)	Factor (dB)	Reading (dBuV)	Level (dBuV)	Limit (dBuV)	Margin (dB)	Detector
1	0.1539	10.06	35.96	46.02	65.78	-19.76	QP
2	0.1539	10.06	20.12	30.18	55.78	-25.60	AVG
3	0.1740	10.06	33.47	43.53	64.76	-21.23	QP
4	0.1740	10.06	19.48	29.54	54.76	-25.22	AVG
5	0.2020	10.06	30.44	40.50	63.52	-23.02	QP
6	0.2020	10.06	19.44	29.50	53.52	-24.02	AVG
7	0.2220	10.05	28.07	38.12	62.74	-24.62	QP
8	0.2220	10.05	17.96	28.01	52.74	-24.73	AVG
9	0.2540	10.03	25.55	35.58	61.62	-26.04	QP
10	0.2540	10.03	17.21	27.24	51.62	-24.38	AVG
11	0.2740	10.02	24.71	34.73	60.99	-26.26	QP
12	0.2740	10.02	16.88	26.90	50.99	-24.09	AVG



Test Mode :	Mode 1, Band 3		
AC Power :	AC 120V/60Hz	Phase:	LINE
Temperature :	26°C	Humidity:	60%
Pressure(mbar) :	1002	Date:	2019-07-22

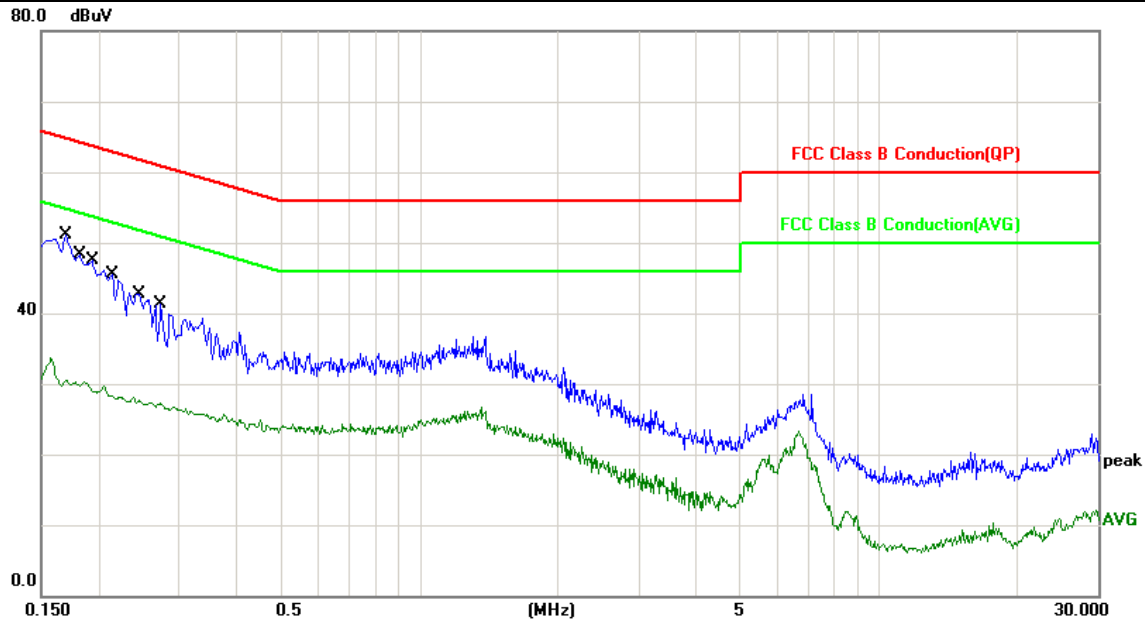

No.	Frequency (MHz)	Factor (dB)	Reading (dBuV)	Level (dBuV)	Limit (dBuV)	Margin (dB)	Detector
1	0.1700	10.06	32.78	42.84	64.96	-22.12	QP
2	0.1700	10.06	21.35	31.41	54.96	-23.55	AVG
3	0.1819	10.06	30.13	40.19	64.39	-24.20	QP
4	0.1819	10.06	18.57	28.63	54.39	-25.76	AVG
5	0.1945	10.06	28.93	38.99	63.84	-24.85	QP
6	0.1945	10.06	18.35	28.41	53.84	-25.43	AVG
7	0.2140	10.05	26.98	37.03	63.04	-26.01	QP
8	0.2140	10.05	17.91	27.96	53.04	-25.08	AVG
9	0.2460	10.03	24.32	34.35	61.89	-27.54	QP
10	0.2460	10.03	17.27	27.30	51.89	-24.59	AVG
11	0.2740	10.02	22.98	33.00	60.99	-27.99	QP
12	0.2740	10.02	16.81	26.83	50.99	-24.16	AVG

Note: Measurement Level = Reading Level + Correct Factor



Test Mode :	Mode 1, Band 3		
AC Power :	AC 120V/60Hz	Phase:	NEUTRAL
Temperature :	26°C	Humidity:	60%
Pressure(mbar) :	1002	Date:	2019-07-22

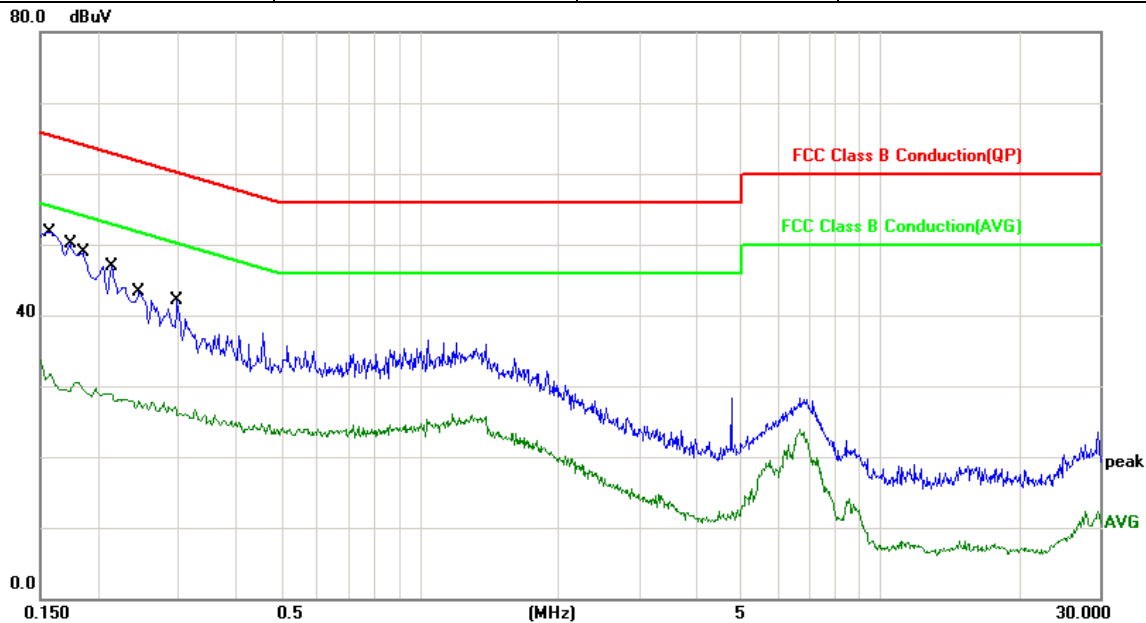

No.	Frequency (MHz)	Factor (dB)	Reading (dBuV)	Level (dBuV)	Limit (dBuV)	Margin (dB)	Detector
1	0.1580	10.06	34.10	44.16	65.56	-21.40	QP
2	0.1580	10.06	21.58	31.64	55.56	-23.92	AVG
3	0.1740	10.06	31.60	41.66	64.76	-23.10	QP
4	0.1740	10.06	19.26	29.32	54.76	-25.44	AVG
5	0.1860	10.06	30.39	40.45	64.21	-23.76	QP
6	0.1860	10.06	19.42	29.48	54.21	-24.73	AVG
7	0.2140	10.05	27.72	37.77	63.04	-25.27	QP
8	0.2140	10.05	18.36	28.41	53.04	-24.63	AVG
9	0.2460	10.03	24.85	34.88	61.89	-27.01	QP
10	0.2460	10.03	17.32	27.35	51.89	-24.54	AVG
11	0.2980	10.00	22.22	32.22	60.30	-28.08	QP
12	0.2980	10.00	16.19	26.19	50.30	-24.11	AVG



Test Mode :	Mode 1, Band 4		
AC Power :	AC 120V/60Hz	Phase:	LINE
Temperature :	26°C	Humidity:	60%
Pressure(mbar) :	1002	Date:	2019-07-22

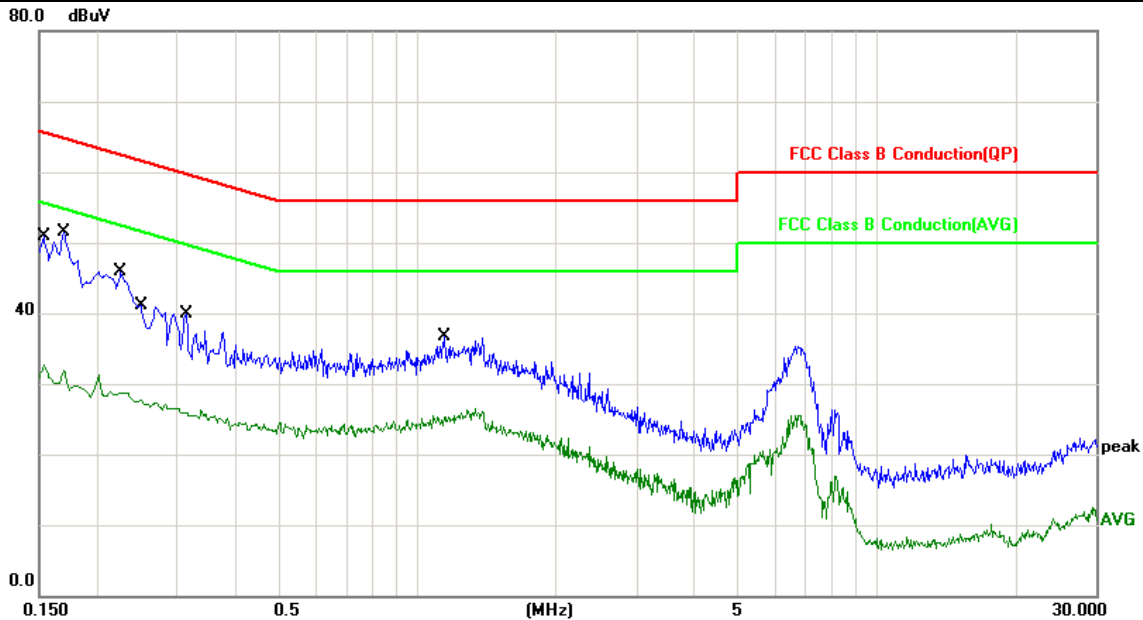

No.	Frequency (MHz)	Factor (dB)	Reading (dBuV)	Level (dBuV)	Limit (dBuV)	Margin (dB)	Detector
1	0.1539	10.06	34.41	44.47	65.78	-21.31	QP
2	0.1539	10.06	22.09	32.15	55.78	-23.63	AVG
3	0.1700	10.06	32.09	42.15	64.96	-22.81	QP
4	0.1700	10.06	19.36	29.42	54.96	-25.54	AVG
5	0.2260	10.05	26.55	36.60	62.59	-25.99	QP
6	0.2260	10.05	17.94	27.99	52.59	-24.60	AVG
7	0.2500	10.03	24.78	34.81	61.75	-26.94	QP
8	0.2500	10.03	17.24	27.27	51.75	-24.48	AVG
9	0.3140	10.00	21.79	31.79	59.86	-28.07	QP
10	0.3140	10.00	15.95	25.95	49.86	-23.91	AVG
11	1.1460	10.26	19.54	29.80	56.00	-26.20	QP
12	1.1460	10.26	14.31	24.57	46.00	-21.43	AVG

Note: Measurement Level = Reading Level + Correct Factor



Test Mode :	Mode 1, Band 4		
AC Power :	AC 120V/60Hz	Phase:	NEUTRAL
Temperature :	26°C	Humidity:	60%
Pressure(mbar) :	1002	Date:	2019-07-22

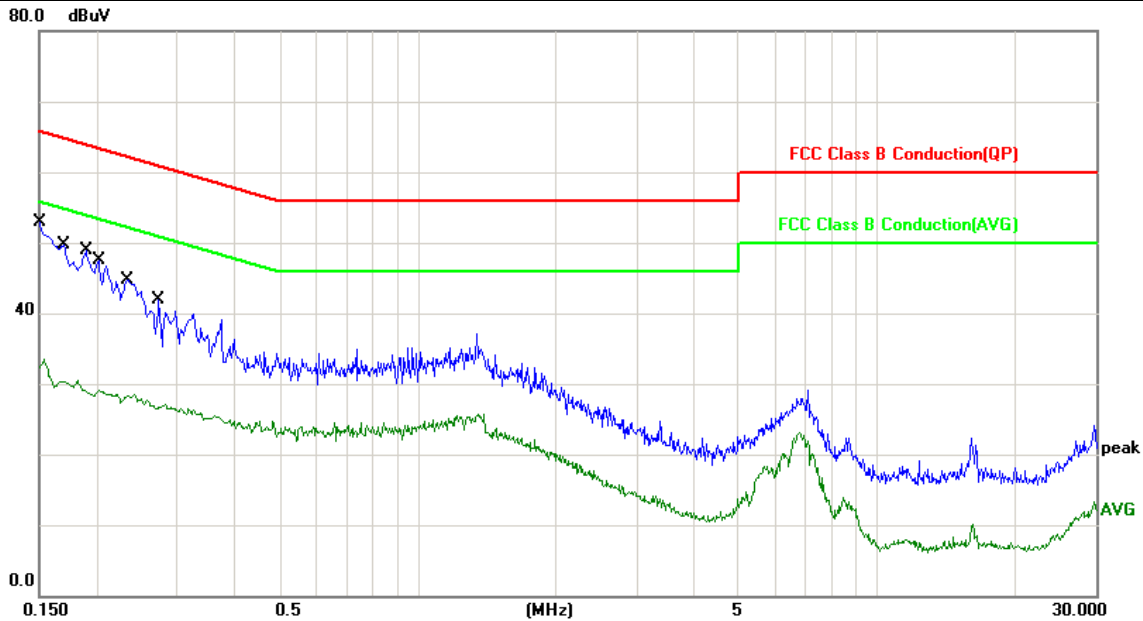

No.	Frequency (MHz)	Factor (dB)	Reading (dBuV)	Level (dBuV)	Limit (dBuV)	Margin (dB)	Detector
1	0.1500	10.06	34.70	44.76	65.99	-21.23	QP
2	0.1500	10.06	21.14	31.20	55.99	-24.79	AVG
3	0.1700	10.06	31.90	41.96	64.96	-23.00	QP
4	0.1700	10.06	19.27	29.33	54.96	-25.63	AVG
5	0.1900	10.06	29.73	39.79	64.03	-24.24	QP
6	0.1900	10.06	18.85	28.91	54.03	-25.12	AVG
7	0.2020	10.06	28.64	38.70	63.52	-24.82	QP
8	0.2020	10.06	18.87	28.93	53.52	-24.59	AVG
9	0.2340	10.04	25.84	35.88	62.30	-26.42	QP
10	0.2340	10.04	17.89	27.93	52.30	-24.37	AVG
11	0.2740	10.02	23.36	33.38	60.99	-27.61	QP
12	0.2740	10.02	16.84	26.86	50.99	-24.13	AVG



6. Test of Spurious Emission (Radiated)

6.1. Test Limit

Undesirable emission limits. Except as shown in paragraph (b)(7) of this section, the maximum emissions outside of the frequency bands of operation shall be attenuated in accordance with the following limits:

- (1) For transmitters operating in the 5.15-5.25 GHz band: All emissions outside of the 5.15-5.35 GHz band shall not exceed an e.i.r.p. of -27 dBm/MHz.
- (2) For transmitters operating in the 5.25-5.35 GHz band: All emissions outside of the 5.15-5.35 GHz band shall not exceed an e.i.r.p. of -27 dBm/MHz.
- (3) For transmitters operating in the 5.47-5.725 GHz band: All emissions outside of the 5.47-5.725 GHz band shall not exceed an e.i.r.p. of -27 dBm/MHz.
- (4) For transmitters operating in the 5.725-5.85 GHz band:
All emissions shall be limited to a level of -27 dBm/MHz at 75 MHz or more above or below the band edge increasing linearly to 10 dBm/MHz at 25 MHz above or below the band edge, and from 25MHz above or below the band edge increasing linearly to a level of 15.6 dBm/MHz at 5 MHz above or below the band edge, and from 5 MHz above or below the band edge increasing linearly to a level of 27dBm/MHz at the band edge.
- (5) The emission measurements shall be performed using a minimum resolution bandwidth of 1 MHz. A lower resolution bandwidth may be employed near the band edge, when necessary, provided the measured energy is integrated to show the total power over 1 MHz.
- (6) Unwanted emissions below 1 GHz must comply with the general field strength limits set forth in §15.209. Further, any U-NII devices using an AC power line are required to comply also with the conducted limits set forth in §15.207.
- (7) The provisions of §15.205 apply to intentional radiators operating under this section.
- (8) When measuring the emission limits, the nominal carrier frequency shall be adjusted as close to the upper and lower frequency band edges as the design of the equipment permits.

6.2. Test Procedures

- a. The EUT was placed on a rotatable table top 0.8 meter above ground.
- b. The EUT was set 3 meters from the interference receiving antenna which was mounted on the top of a variable height antenna tower.
- c. The table was rotated 360 degrees to determine the position of the highest radiation.
- d. The antenna is a broadband antenna and its height is varied between one meter and four meters above ground to find the maximum value of the field strength both horizontal polarization and vertical polarization of the antenna are set to make the measurement.
- e. For each suspected emission the EUT was arranged to its worst case and then tune the antenna tower (from 1 M to 4 M) and turn table (from 0 degree to 360 degrees) to find the maximum reading.
- f. Set the test-receiver system to Peak or CISPR quasi-peak Detect Function and specified bandwidth with Maximum Hold Mode.
- g. If the emission level of the EUT in peak mode was 3 dB lower than the limit specified, then testing will be stopped and peak values of EUT will be reported, otherwise, the emissions which do not have 3 dB margin will be repeated one by one using the quasi-peak method and reported.
- h. For testing above 1GHz, the emission level of the EUT in peak mode was 20dB lower than average limit (that means the emission level in peak mode also complies with the limit in average mode), then testing will be stopped and peak values of EUT will be reported, otherwise, the emissions will be measured in average mode again and reported.
- i. "Cone of radiation" has been considered to be 3dB bandwidth of the measurement antenna.



6.3. Typical Test Setup

Below 30MHz test setup

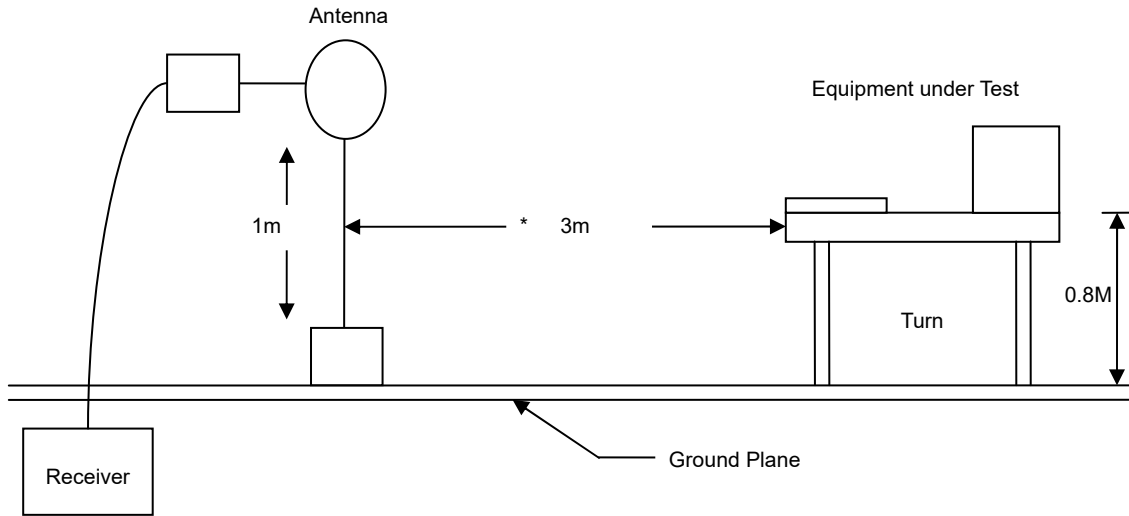

30MHz- 1GHz Test Setup

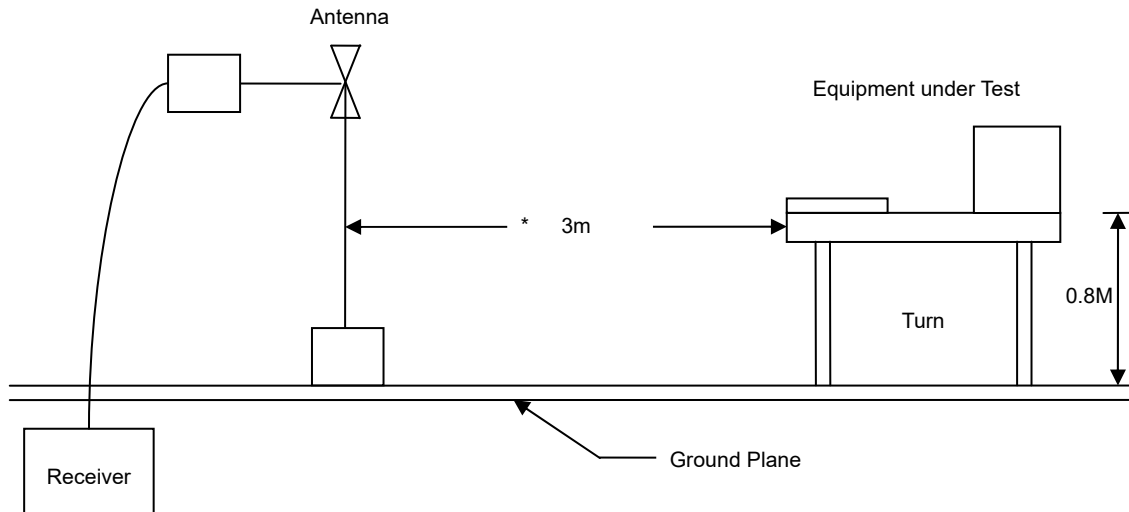

Above 1GHz Test Setup

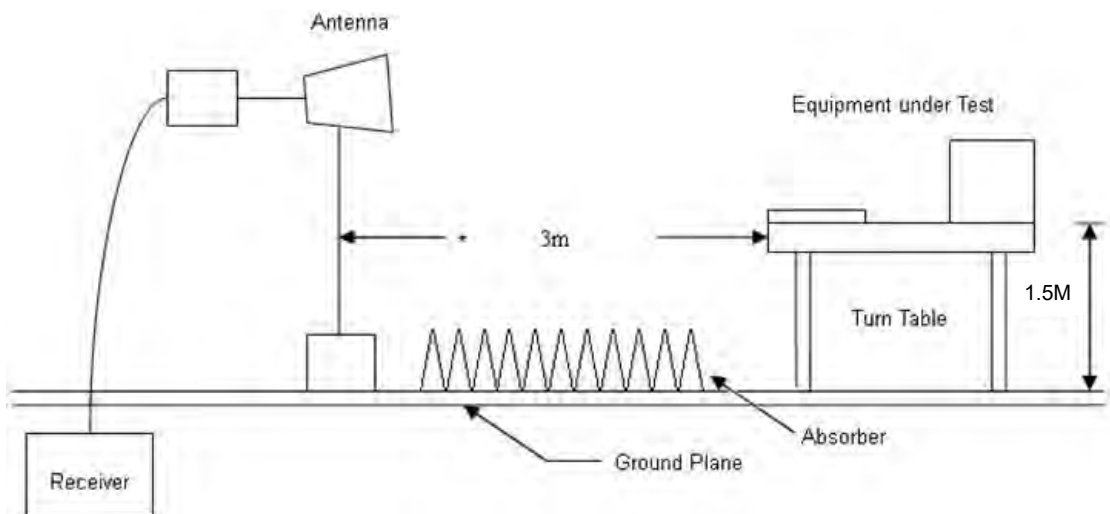

**6.4. Test Result and Data (9kHz ~ 30MHz)**

The 9kHz - 30MHz spurious emission is under limit 20dB more.

6.5. Test Result and Data (30MHz ~ 1GHz)

Power	: DC 3.3V	Temperature	: 24 °C
Test Mode	: Mode 1, Band 1	Humidity	: 54 %
Test date	: Jul. 21, 2019	Atmospheric Pressure	: 1010 hpa

Frequency (MHz)	Correct Factor (dB)	Reading level (dBuV)	Measure Level (dBuV/m)	Limit 3m (dBuV/m)	Safe Margin (dB)	Detector mode (PK/QP)	AntPol. H/V
119.2400	-10.36	45.45	35.09	43.50	-8.41	peak	H
208.4800	-9.62	46.28	36.66	43.50	-6.84	peak	H
239.5200	-7.03	47.23	40.20	46.00	-5.80	QP	H
277.3500	-6.51	45.68	39.17	46.00	-6.83	QP	H
481.0500	-1.97	40.78	38.81	46.00	-7.19	peak	H
720.6400	-0.71	32.93	32.22	46.00	-13.78	peak	H
33.8800	-7.99	41.68	33.69	40.00	-6.31	peak	V
206.5399	-8.63	45.53	36.90	43.50	-6.60	peak	V
239.5200	-8.93	46.33	37.40	46.00	-8.60	peak	V
277.3500	-10.51	45.35	34.84	46.00	-11.16	peak	V
482.0200	-2.03	37.28	35.25	46.00	-10.75	peak	V
692.5100	-2.23	35.85	33.62	46.00	-12.38	peak	V

Note: Level = Reading + Factor

Margin = Level – Limit

Factor= Antenna Factor + Cable Loss - Amplifier Factor



Power	:	DC 3.3V	Temperature	:	24 °C
Test Mode	:	Mode 1, Band 2	Humidity	:	54 %
Test date	:	Jul. 21, 2019	Atmospheric Pressure	:	1010 hpa

Frequency (MHz)	Correct Factor (dB)	Reading level (dBuV)	Measure Level (dBuV/m)	Limit 3m (dBuV/m)	Safe Margin (dB)	Detector mode (PK/QP)	AntPol. H/V
132.8199	-11.46	47.20	35.74	43.50	-7.76	peak	H
179.3799	-9.97	46.28	36.31	43.50	-7.19	peak	H
235.6400	-7.29	47.35	40.06	46.00	-5.94	QP	H
285.1099	-6.27	44.46	38.19	46.00	-7.81	QP	H
478.1400	-2.00	40.76	38.76	46.00	-7.24	peak	H
567.3799	-3.55	36.82	33.27	46.00	-12.73	peak	H
38.7299	-11.19	44.27	33.08	40.00	-6.92	peak	V
151.2500	-13.20	44.40	31.20	43.50	-12.30	peak	V
206.5399	-8.63	43.53	34.90	43.50	-8.60	peak	V
244.3700	-9.23	47.20	37.97	46.00	-8.03	peak	V
474.2600	-2.20	38.31	36.11	46.00	-9.89	peak	V
582.8999	-3.55	32.27	28.72	46.00	-17.28	peak	V

Note: Level = Reading + Factor

Margin = Level – Limit

Factor= Antenna Factor + Cable Loss - Amplifier Factor



Power	: DC 3.3V	Temperature	: 24 °C
Test Mode	: Mode 1, Band 3	Humidity	: 54 %
Test date	: Jul. 21, 2019	Atmospheric Pressure	: 1010 hpa

Frequency (MHz)	Correct Factor (dB)	Reading level (dBuV)	Measure Level (dBuV/m)	Limit 3m (dBuV/m)	Safe Margin (dB)	Detector mode (PK/QP)	AntPol. H/V
145.4299	-13.07	47.16	34.09	43.50	-9.41	peak	H
179.3799	-9.97	46.28	36.31	43.50	-7.19	peak	H
244.3700	-6.79	47.23	40.44	46.00	-5.56	QP	H
276.3798	-6.63	46.54	39.91	46.00	-6.09	QP	H
479.1100	-1.96	39.81	37.85	46.00	-8.15	peak	H
761.3799	0.99	34.40	35.39	46.00	-10.61	peak	H
36.7899	-9.79	42.28	32.49	40.00	-7.51	peak	V
179.3799	-13.91	49.19	35.28	43.50	-8.22	peak	V
205.5700	-8.64	43.93	35.29	43.50	-8.21	peak	V
380.1700	-6.57	40.56	33.99	46.00	-12.01	peak	V
477.1700	-2.06	39.88	37.82	46.00	-8.18	peak	V
717.7300	-1.08	35.70	34.62	46.00	-11.38	peak	V

Note: Level = Reading + Factor
Margin = Level – Limit
Factor= Antenna Factor + Cable Loss - Amplifier Factor



Power	: DC 3.3V	Temperature	: 24 °C
Test Mode	: Mode 1, Band 4	Humidity	: 54 %
Test date	: Jul. 21, 2019	Atmospheric Pressure	: 1010 hpa

Frequency (MHz)	Correct Factor (dB)	Reading level (dBuV)	Measure Level (dBuV/m)	Limit 3m (dBuV/m)	Safe Margin (dB)	Detector mode (PK/QP)	AntPol. H/V
132.8199	-11.46	47.70	36.24	43.50	-7.26	peak	H
193.9299	-10.18	44.73	34.55	43.50	-8.95	peak	H
244.3700	-6.79	47.31	40.52	46.00	-5.48	QP	H
299.6600	-8.46	47.52	39.06	46.00	-6.94	QP	H
481.0500	-1.97	40.28	38.31	46.00	-7.69	peak	H
754.5900	0.83	35.58	36.41	46.00	-9.59	peak	H
35.8200	-9.14	40.90	31.76	40.00	-8.24	peak	V
185.2000	-11.43	45.02	33.59	43.50	-9.91	peak	V
212.3600	-8.40	44.56	36.16	43.50	-7.34	peak	V
237.5800	-8.69	46.94	38.25	46.00	-7.75	peak	V
480.0800	-1.92	39.10	37.18	46.00	-8.82	peak	V
656.6200	-1.90	36.51	34.61	46.00	-11.39	peak	V

Note: Level = Reading + Factor
 Margin = Level – Limit
 Factor= Antenna Factor + Cable Loss - Amplifier Factor

**6.6. Test Result and Data (1GHz ~ 40GHz)**

Power	:	DC 3.3V	Temperature	:	24 °C
Test Mode	:	Mode 1, CH36 Band 1	Humidity	:	54 %
Test date	:	Jul. 21, 2019	Atmospheric Pressure	:	1010 hpa

Frequency (MHz)	Factor (dB/m)	Reading (dBuV)	Level (dBuV/m)	Limit (dBuV/m)	Margin (dB)	Detector mode (PK/AVG)	AntPol. H/V
5150.000	1.73	38.59	40.32	74.00	-33.68	peak	H
5150.000	1.73	28.48	30.21	54.00	-23.79	AVG	H
10360.000	12.85	37.46	50.31	68.20	-17.89	peak	H
15540.000	25.25	26.85	52.10	74.00	-21.90	peak	H
15540.000	25.25	17.26	42.51	54.00	-11.49	AVG	H
5150.000	1.73	58.93	60.66	74.00	-13.34	peak	V
5150.000	1.73	44.18	45.91	54.00	-8.09	peak	V
10360.000	12.85	38.47	51.32	68.20	-16.88	peak	V
15540.000	25.25	29.58	54.83	74.00	-19.17	peak	V
15540.000	25.25	19.27	44.52	54.00	-9.48	peak	V

Note: Level = Reading + Factor

Margin = Level – Limit

Factor= Antenna Factor + Cable Loss - Amplifier Factor



Power	: DC 3.3V	Temperature	: 24 °C
Test Mode	: Mode 1, CH44 Band 1	Humidity	: 54 %
Test date	: Jul. 21, 2019	Atmospheric Pressure	: 1010 hpa

Frequency (MHz)	Factor (dB/m)	Reading (dBuV)	Level (dBuV/m)	Limit (dBuV/m)	Margin (dB)	Detector mode (PK/AVG)	AntPol. H/V
5150.000	1.73	39.59	41.32	74.00	-32.68	peak	H
5150.000	1.73	28.68	30.41	54.00	-23.59	AVG	H
5350.000	1.89	40.00	41.89	74.00	-32.11	peak	H
5350.000	1.89	28.74	30.63	54.00	-23.37	AVG	H
10440.000	13.03	37.44	50.47	68.20	-17.73	peak	H
15660.000	25.30	27.09	52.39	74.00	-21.61	peak	H
15660.000	25.30	16.68	41.98	54.00	-12.02	AVG	H
5150.000	1.73	40.19	41.92	74.00	-32.08	peak	V
5150.000	1.73	28.81	30.54	54.00	-23.46	AVG	V
5350.000	1.89	39.85	41.74	74.00	-32.26	peak	V
5350.000	1.89	28.97	30.86	54.00	-23.14	AVG	V
10440.000	13.03	39.10	52.13	68.20	-16.07	peak	V
15660.000	25.30	29.02	54.32	74.00	-19.68	peak	V
15660.000	25.30	18.77	44.07	54.00	-9.93	AVG	V

Note: Level = Reading + Factor

Margin = Level – Limit

Factor= Antenna Factor + Cable Loss - Amplifier Factor



Power	:	DC 3.3V	Temperature	:	24 °C
Test Mode	:	Mode 1, CH48 band 1	Humidity	:	54 %
Test date	:	Jul. 21, 2019	Atmospheric Pressure	:	1010 hpa

Frequency (MHz)	Factor (dB/m)	Reading (dBuV)	Level (dBuV/m)	Limit (dBuV/m)	Margin (dB)	Detector mode (PK/AVG)	AntPol. H/V
5350.000	1.89	39.67	41.56	74.00	-32.44	peak	H
5350.000	1.89	28.53	30.42	54.00	-23.58	AVG	H
10480.000	13.12	37.44	50.56	68.20	-17.64	peak	H
15720.000	25.33	27.77	53.10	74.00	-20.90	peak	H
15720.000	25.33	17.34	42.67	54.00	-11.33	AVG	H
5350.000	1.89	39.97	41.86	74.00	-32.14	peak	V
5350.000	1.89	28.54	30.43	54.00	-23.57	AVG	V
10480.000	13.12	38.74	51.86	68.20	-16.34	peak	V
15720.000	25.33	28.79	54.12	74.00	-19.88	peak	V
15720.000	25.33	18.54	43.87	54.00	-10.13	AVG	V

Note: Level = Reading + Factor

Margin = Level – Limit

Factor= Antenna Factor + Cable Loss - Amplifier Factor



Power	: DC 3.3V	Temperature	: 24 °C
Test Mode	: Mode 1, CH52 Band 2	Humidity	: 54 %
Test date	: Jul. 21, 2019	Atmospheric Pressure	: 1010 hpa

Frequency (MHz)	Factor (dB/m)	Reading (dBuV)	Level (dBuV/m)	Limit (dBuV/m)	Margin (dB)	Detector mode (PK/AVG)	AntPol. H/V
5350.000	1.89	39.86	41.75	74.00	-32.25	peak	H
5350.000	1.89	28.74	30.63	54.00	-23.37	AVG	H
10520.000	13.22	37.46	50.68	68.20	-17.52	peak	H
15780.000	25.36	27.10	52.46	74.00	-21.54	peak	H
15780.000	25.36	16.75	42.11	54.00	-11.89	AVG	H
5350.000	1.89	39.84	41.73	74.00	-32.27	peak	V
5350.000	1.89	28.56	30.45	54.00	-23.55	AVG	V
10520.000	13.22	39.41	52.63	68.20	-15.57	peak	V
15780.000	25.36	28.67	54.03	74.00	-19.97	peak	V
15780.000	25.36	18.21	43.57	54.00	-10.43	AVG	V

Note: Level = Reading + Factor

Margin = Level – Limit

Factor= Antenna Factor + Cable Loss - Amplifier Factor



Power	: DC 3.3V	Temperature	: 24 °C
Test Mode	: Mode 1, CH60 Band 2	Humidity	: 54 %
Test date	: Jul. 21, 2019	Atmospheric Pressure	: 1010 hpa

Frequency (MHz)	Factor (dB/m)	Reading (dBuV)	Level (dBuV/m)	Limit (dBuV/m)	Margin (dB)	Detector mode (PK/AVG)	AntPol. H/V
5350.000	1.89	39.36	41.25	74.00	-32.75	peak	H
5350.000	1.89	28.54	30.43	54.00	-23.57	AVG	H
10600.000	13.46	37.33	50.79	74.00	-23.21	peak	H
10600.000	13.46	25.49	38.95	54.00	-15.05	AVG	H
15900.000	25.41	26.90	52.31	74.00	-21.69	peak	H
15900.000	25.41	14.84	40.25	54.00	-13.75	AVG	H
5350.000	1.89	46.18	48.07	74.00	-25.93	peak	V
5350.000	1.89	31.76	33.65	54.00	-20.35	AVG	V
10600.000	13.46	38.68	52.14	74.00	-21.86	peak	V
10600.000	13.46	28.21	41.67	54.00	-12.33	AVG	V
15900.000	25.41	28.90	54.31	74.00	-19.69	peak	V
15900.000	25.41	18.82	44.23	54.00	-9.77	AVG	V

Note: Level = Reading + Factor

Margin = Level – Limit

Factor= Antenna Factor + Cable Loss - Amplifier Factor



Power	:	DC 3.3V	Temperature	:	24 °C
Test Mode	:	Mode 1, CH64 Band 2	Humidity	:	54 %
Test date	:	Jul. 21, 2019	Atmospheric Pressure	:	1010 hpa

Frequency (MHz)	Factor (dB/m)	Reading (dBuV)	Level (dBuV/m)	Limit (dBuV/m)	Margin (dB)	Detector mode (PK/AVG)	AntPol. H/V
5350.000	1.89	39.99	41.88	74.00	-32.12	peak	H
5350.000	1.89	28.60	30.49	54.00	-23.51	AVG	H
10640.000	13.58	37.30	50.88	74.00	-23.12	peak	H
10640.000	13.58	25.24	38.82	54.00	-15.18	AVG	H
15960.000	25.44	27.23	52.67	74.00	-21.33	peak	H
15960.000	25.44	16.94	42.38	54.00	-11.62	AVG	H
5350.000	1.89	60.75	62.64	74.00	-11.36	peak	V
5350.000	1.89	46.60	48.49	54.00	-5.51	AVG	V
10640.000	13.58	38.55	52.13	74.00	-21.87	peak	V
10640.000	13.58	27.74	41.32	54.00	-12.68	AVG	V
15960.000	25.44	28.97	54.41	74.00	-19.59	peak	V
15960.000	25.44	19.13	44.57	54.00	-9.43	AVG	V

Note: Level = Reading + Factor
Margin = Level – Limit
Factor= Antenna Factor + Cable Loss - Amplifier Factor



Power	: DC 3.3V	Temperature	: 24 °C
Test Mode	: Mode 1, CH100 Band 3	Humidity	: 54 %
Test date	: Jul. 21, 2019	Atmospheric Pressure	: 1010 hpa

Frequency (MHz)	Factor (dB/m)	Reading (dBuV)	Level (dBuV/m)	Limit (dBuV/m)	Margin (dB)	Detector mode (PK/AVG)	AntPol. H/V
5460.000	1.99	39.33	41.32	74.00	-32.68	peak	H
5460.000	1.99	28.21	30.20	54.00	-23.80	AVG	H
5470.000	1.99	39.47	41.46	68.20	-26.74	peak	H
11000.000	14.67	35.90	50.57	74.00	-23.43	peak	H
11000.000	14.67	24.57	39.24	54.00	-14.76	AVG	H
16500.000	29.95	23.33	53.28	68.20	-14.92	peak	H
5460.000	1.99	50.03	52.02	74.00	-21.98	peak	V
5460.000	1.99	35.63	37.62	54.00	-16.38	AVG	V
5470.000	1.99	60.93	62.92	68.20	-5.28	peak	V
11000.000	14.67	38.45	53.12	74.00	-20.88	peak	V
11000.000	14.67	27.90	42.57	54.00	-11.43	AVG	V
16500.000	29.95	25.03	54.98	68.20	-13.22	peak	V

Note: Level = Reading + Factor

Margin = Level – Limit

Factor= Antenna Factor + Cable Loss - Amplifier Factor



Power	: DC 3.3V	Temperature	: 24 °C
Test Mode	: Mode 1, CH116 Band 3	Humidity	: 54 %
Test date	: Jul. 21, 2019	Atmospheric Pressure	: 1010 hpa

Frequency (MHz)	Factor (dB/m)	Reading (dBuV)	Level (dBuV/m)	Limit (dBuV/m)	Margin (dB)	Detector mode (PK/AVG)	AntPol. H/V
5460.000	1.99	39.54	41.53	74.00	-32.47	peak	H
5460.000	1.99	28.46	30.45	54.00	-23.55	AVG	H
5470.000	1.99	39.60	41.59	68.20	-26.61	peak	H
5725.000	2.58	39.93	42.51	68.20	-25.69	peak	H
11160.000	15.05	35.98	51.03	74.00	-22.97	peak	H
11160.000	15.05	24.62	39.67	54.00	-14.33	AVG	H
16740.000	29.65	24.09	53.74	68.20	-14.46	peak	H
5460.000	1.99	39.60	41.59	74.00	-32.41	peak	V
5460.000	1.99	28.43	30.42	54.00	-23.58	AVG	V
5470.000	1.99	39.94	41.93	68.20	-26.27	peak	V
5725.000	2.58	39.01	41.59	68.20	-26.61	peak	V
11160.000	15.05	38.19	53.24	74.00	-20.76	peak	V
11160.000	15.05	27.62	42.67	54.00	-11.33	AVG	V
16740.000	29.65	22.19	51.84	68.20	-16.36	peak	V

Note: Level = Reading + Factor
Margin = Level – Limit
Factor= Antenna Factor + Cable Loss - Amplifier Factor



Power	:	DC 3.3V	Temperature	:	24 °C
Test Mode	:	Mode 1, CH140 Band 3	Humidity	:	54 %
Test date	:	Jul. 21, 2019	Atmospheric Pressure	:	1010 hpa

Frequency (MHz)	Factor (dB/m)	Reading (dBuV)	Level (dBuV/m)	Limit (dBuV/m)	Margin (dB)	Detector mode (PK/AVG)	AntPol. H/V
5725.000	2.58	39.86	42.44	68.20	-25.76	peak	H
11400.000	15.62	35.82	51.44	74.00	-22.56	peak	H
11400.000	15.62	24.57	40.19	54.00	-13.81	AVG	H
17100.000	29.73	24.12	53.85	68.20	-14.35	peak	H
5725.000	2.58	62.56	65.14	68.20	-3.06	peak	V
11400.000	15.62	36.86	52.48	74.00	-21.52	peak	V
11400.000	15.62	25.74	41.36	54.00	-12.64	AVG	V
17100.000	29.73	24.78	54.51	68.20	-13.69	peak	V

Note: Level = Reading + Factor

Margin = Level – Limit

Factor= Antenna Factor + Cable Loss - Amplifier Factor



Power	: DC 3.3V	Temperature	: 24 °C
Test Mode	: Mode 1, CH149 Band 4	Humidity	: 54 %
Test date	: Jul. 21, 2019	Atmospheric Pressure	: 1010 hpa

Frequency (MHz)	Factor (dB/m)	Reading (dBuV)	Level (dBuV/m)	Limit (dBuV/m)	Margin (dB)	Detector mode (PK/AVG)	AntPol. H/V
5650.000	2.39	38.84	41.23	68.20	-26.97	peak	H
5700.000	2.52	39.15	41.67	105.20	-63.53	peak	H
5720.000	2.57	48.77	51.34	110.80	-59.46	peak	H
5725.000	2.58	61.79	64.37	122.20	-57.83	peak	H
11490.000	15.84	35.80	51.64	74.00	-22.36	peak	H
11490.000	15.84	24.36	40.20	54.00	-13.80	AVG	H
17235.000	30.26	23.22	53.48	68.20	-14.72	peak	H
5650.000	2.39	39.18	41.57	68.20	-26.63	peak	V
5700.000	2.52	41.57	44.09	105.20	-61.11	peak	V
5720.000	2.57	58.77	61.34	110.80	-49.46	peak	V
5725.000	2.58	69.83	72.41	122.20	-49.79	peak	V
11490.000	15.84	36.90	52.74	74.00	-21.26	peak	V
11490.000	15.84	25.83	41.67	54.00	-12.33	AVG	V
17235.000	30.26	24.60	54.86	68.20	-13.34	peak	V

Note: Level = Reading + Factor
Margin = Level – Limit
Factor= Antenna Factor + Cable Loss - Amplifier Factor



Power	: DC 3.3V	Temperature	: 24 °C
Test Mode	: Mode 1, CH157 Band 4	Humidity	: 54 %
Test date	: Jul. 21, 2019	Atmospheric Pressure	: 1010 hpa

Frequency (MHz)	Factor (dB/m)	Reading (dBuV)	Level (dBuV/m)	Limit (dBuV/m)	Margin (dB)	Detector mode (PK/AVG)	AntPol. H/V
5650.000	2.39	39.22	41.61	68.20	-26.59	peak	H
5700.000	2.52	40.16	42.68	105.20	-62.52	peak	H
5720.000	2.57	40.16	42.73	110.80	-68.07	peak	H
5725.000	2.58	39.22	41.80	122.20	-80.40	peak	H
5850.000	2.89	38.96	41.85	122.20	-80.35	peak	H
5855.000	2.90	39.52	42.42	110.80	-68.38	peak	H
5875.000	2.95	39.23	42.18	105.20	-63.02	peak	H
5925.000	3.07	38.26	41.33	68.20	-26.87	peak	H
11570.000	16.00	35.40	51.40	74.00	-22.60	peak	H
11570.000	16.00	23.87	39.87	54.00	-14.13	AVG	H
17355.000	30.74	22.65	53.39	68.20	-14.81	peak	H
5650.000	2.39	39.37	41.76	68.20	-26.44	peak	V
5700.000	2.52	39.50	42.02	105.20	-63.18	peak	V
5700.000	2.52	39.11	41.63	105.20	-63.57	peak	V
5720.000	2.57	39.57	42.14	110.80	-68.66	peak	V
5725.000	2.58	38.78	41.36	122.20	-80.84	peak	V
5850.000	2.89	39.51	42.40	122.20	-79.80	peak	V
5875.000	2.95	38.47	41.42	105.20	-63.78	peak	V
5925.000	3.07	37.60	40.67	68.20	-27.53	peak	V
11570.000	16.00	36.86	52.86	74.00	-21.14	peak	V
11570.000	16.00	25.69	41.69	54.00	-12.31	AVG	V
17355.000	30.74	23.79	54.53	68.20	-13.67	peak	V

Note: Level = Reading + Factor
Margin = Level – Limit
Factor= Antenna Factor + Cable Loss - Amplifier Factor



Power	: DC 3.3V	Temperature	: 24 °C
Test Mode	: Mode 1, CH165 Band4	Humidity	: 54 %
Test date	: Jul. 21, 2019	Atmospheric Pressure	: 1010 hpa

Frequency (MHz)	Factor (dB/m)	Reading (dBuV)	Level (dBuV/m)	Limit (dBuV/m)	Margin (dB)	Detector mode (PK/AVG)	AntPol. H/V
5850.000	2.89	39.04	41.93	122.20	-80.27	peak	H
5855.000	2.90	39.11	42.01	110.80	-68.79	peak	H
5875.000	2.95	38.39	41.34	105.20	-63.86	peak	H
5925.000	3.07	39.67	42.74	68.20	-25.46	peak	H
11650.000	16.16	35.26	51.42	74.00	-22.58	peak	H
11650.000	16.16	24.07	40.23	54.00	-13.77	AVG	H
17475.000	31.21	22.46	53.67	68.20	-14.53	peak	H
5850.000	2.89	58.06	60.95	122.20	-61.25	peak	V
5855.000	2.90	55.07	57.97	110.80	-52.83	peak	V
5875.000	2.95	39.82	42.77	105.20	-62.43	peak	V
5925.000	3.07	38.48	41.55	68.20	-26.65	peak	V
11650.000	16.16	37.50	53.66	74.00	-20.34	peak	V
11650.000	16.16	25.98	42.14	54.00	-11.86	AVG	V
17475.000	31.21	23.51	54.72	68.20	-13.48	peak	V

Note: Level = Reading + Factor
Margin = Level – Limit
Factor= Antenna Factor + Cable Loss - Amplifier Factor



Power	: DC 3.3V	Temperature	: 24 °C
Test Mode	: Mode 2, CH36 Band 1	Humidity	: 54 %
Test date	: Jul. 21, 2019	Atmospheric Pressure	: 1010 hpa

Frequency (MHz)	Factor (dB/m)	Reading (dBuV)	Level (dBuV/m)	Limit (dBuV/m)	Margin (dB)	Detector mode (PK/AVG)	AntPol. H/V
5150.000	1.73	48.91	50.64	74.00	-23.36	peak	H
5150.000	1.73	34.47	36.20	54.00	-17.80	AVG	H
10360.000	12.85	38.49	51.34	68.20	-16.86	peak	H
15540.000	25.25	27.40	52.65	74.00	-21.35	peak	H
15540.000	25.25	16.12	41.37	54.00	-12.63	AVG	H
5150.000	1.73	60.32	62.05	74.00	-11.95	peak	V
5150.000	1.73	45.87	47.60	54.00	-6.40	AVG	V
10360.000	12.85	40.07	52.92	68.20	-15.28	peak	V
15540.000	25.25	29.40	54.65	74.00	-19.35	peak	V
15540.000	25.25	18.69	43.94	54.00	-10.06	AVG	V

Note: Level = Reading + Factor

Margin = Level – Limit

Factor= Antenna Factor + Cable Loss - Amplifier Factor



Power	: DC 3.3V	Temperature	: 24 °C
Test Mode	: Mode 2, CH44 Band 1	Humidity	: 54 %
Test date	: Jul. 21, 2019	Atmospheric Pressure	: 1010 hpa

Frequency (MHz)	Factor (dB/m)	Reading (dBuV)	Level (dBuV/m)	Limit (dBuV/m)	Margin (dB)	Detector mode (PK/AVG)	AntPol. H/V
5150.000	1.73	39.57	41.30	74.00	-32.70	peak	H
5150.000	1.73	29.95	31.68	54.00	-22.32	AVG	H
5350.000	1.89	39.09	40.98	74.00	-33.02	peak	H
5350.000	1.89	28.86	30.75	54.00	-23.25	AVG	H
10440.000	13.03	38.16	51.19	68.20	-17.01	peak	H
15660.000	25.30	27.63	52.93	74.00	-21.07	peak	H
15660.000	25.30	16.42	41.72	54.00	-12.28	AVG	H
5150.000	1.73	39.62	41.35	74.00	-32.65	peak	V
5150.000	1.73	28.81	30.54	54.00	-23.46	AVG	V
5350.000	1.89	39.44	41.33	74.00	-32.67	peak	V
5350.000	1.89	28.89	30.78	54.00	-23.22	AVG	V
10440.000	13.03	39.68	52.71	68.20	-15.49	peak	V
15660.000	25.30	29.23	54.53	74.00	-19.47	peak	V
15660.000	25.30	19.17	44.47	54.00	-9.53	AVG	V

Note: Level = Reading + Factor
Margin = Level – Limit
Factor= Antenna Factor + Cable Loss - Amplifier Factor



Power	:	DC 3.3V	Temperature	:	24 °C
Test Mode	:	Mode 2, CH48 band 1	Humidity	:	54 %
Test date	:	Jul. 21, 2019	Atmospheric Pressure	:	1010 hpa

Frequency (MHz)	Factor (dB/m)	Reading (dBuV)	Level (dBuV/m)	Limit (dBuV/m)	Margin (dB)	Detector mode (PK/AVG)	AntPol. H/V
5350.000	1.89	38.96	40.85	74.00	-33.15	peak	H
5350.000	1.89	28.78	30.67	54.00	-23.33	AVG	H
10480.000	13.12	38.19	51.31	68.20	-16.89	peak	H
15720.000	25.33	28.28	53.61	74.00	-20.39	peak	H
15720.000	25.33	17.19	42.52	54.00	-11.48	AVG	H
5350.000	1.89	39.46	41.35	74.00	-32.65	peak	V
5350.000	1.89	28.79	30.68	54.00	-23.32	AVG	V
10480.000	13.12	39.21	52.33	68.20	-15.87	peak	V
15720.000	25.33	29.24	54.57	74.00	-19.43	peak	V
15720.000	25.33	18.96	44.29	54.00	-9.71	AVG	V

Note: Level = Reading + Factor

Margin = Level – Limit

Factor= Antenna Factor + Cable Loss - Amplifier Factor



Power	: DC 3.3V	Temperature	: 24 °C
Test Mode	: Mode 2, CH52 Band 2	Humidity	: 54 %
Test date	: Jul. 21, 2019	Atmospheric Pressure	: 1010 hpa

Frequency (MHz)	Factor (dB/m)	Reading (dBuV)	Level (dBuV/m)	Limit (dBuV/m)	Margin (dB)	Detector mode (PK/AVG)	AntPol. H/V
5350.000	1.89	39.34	41.23	74.00	-32.77	peak	H
5350.000	1.89	28.83	30.72	54.00	-23.28	AVG	H
10520.000	13.22	37.50	50.72	68.20	-17.48	peak	H
15780.000	25.36	26.81	52.17	74.00	-21.83	peak	H
15780.000	25.36	15.90	41.26	54.00	-12.74	AVG	H
5350.000	1.89	39.67	41.56	74.00	-32.44	peak	V
5350.000	1.89	28.85	30.74	54.00	-23.26	AVG	V
10520.000	13.22	39.33	52.55	68.20	-15.65	peak	V
15780.000	25.36	29.40	54.76	74.00	-19.24	peak	V
15780.000	25.36	18.83	44.19	54.00	-9.81	AVG	V

Note: Level = Reading + Factor

Margin = Level – Limit

Factor= Antenna Factor + Cable Loss - Amplifier Factor



Power	: DC 3.3V	Temperature	: 24 °C
Test Mode	: Mode 2, CH60 Band 2	Humidity	: 54 %
Test date	: Jul. 21, 2019	Atmospheric Pressure	: 1010 hpa

Frequency (MHz)	Factor (dB/m)	Reading (dBuV)	Level (dBuV/m)	Limit (dBuV/m)	Margin (dB)	Detector mode (PK/AVG)	AntPol. H/V
5350.000	1.89	40.09	41.98	74.00	-32.02	peak	H
5350.000	1.89	28.38	30.27	54.00	-23.73	AVG	H
10600.000	13.46	36.85	50.31	74.00	-23.69	peak	H
10600.000	13.46	25.18	38.64	54.00	-15.36	AVG	H
15900.000	25.41	27.50	52.91	74.00	-21.09	peak	H
15900.000	25.41	15.89	41.30	54.00	-12.70	AVG	H
5350.000	1.89	49.30	51.19	74.00	-22.81	peak	V
5350.000	1.89	33.92	35.81	54.00	-18.19	AVG	V
10600.000	13.46	39.27	52.73	74.00	-21.27	peak	V
10600.000	13.46	27.93	41.39	54.00	-12.61	AVG	V
15900.000	25.41	29.21	54.62	74.00	-19.38	peak	V
15900.000	25.41	19.09	44.50	54.00	-9.50	AVG	V

Note: Level = Reading + Factor
Margin = Level – Limit
Factor= Antenna Factor + Cable Loss - Amplifier Factor



Power	: DC 3.3V	Temperature	: 24 °C
Test Mode	: Mode 2, CH64 Band 2	Humidity	: 54 %
Test date	: Jul. 21, 2019	Atmospheric Pressure	: 1010 hpa

Frequency (MHz)	Factor (dB/m)	Reading (dBuV)	Level (dBuV/m)	Limit (dBuV/m)	Margin (dB)	Detector mode (PK/AVG)	AntPol. H/V
5350.000	1.89	49.25	51.14	74.00	-22.86	peak	H
5350.000	1.89	34.06	35.95	54.00	-18.05	AVG	H
10640.000	13.58	37.20	50.78	74.00	-23.22	peak	H
10640.000	13.58	24.96	38.54	54.00	-15.46	AVG	H
15960.000	25.44	27.64	53.08	74.00	-20.92	peak	H
15960.000	25.44	16.88	42.32	54.00	-11.68	AVG	H
5350.000	1.89	63.42	65.31	74.00	-8.69	peak	V
5350.000	1.89	48.89	50.78	54.00	-3.22	AVG	V
10640.000	13.58	38.78	52.36	74.00	-21.64	peak	V
10640.000	13.58	26.83	40.41	54.00	-13.59	AVG	V
15960.000	25.44	29.33	54.77	74.00	-19.23	peak	V
15960.000	25.44	18.95	44.39	54.00	-9.61	AVG	V

Note: Level = Reading + Factor
Margin = Level – Limit
Factor= Antenna Factor + Cable Loss - Amplifier Factor



Power	: DC 3.3V	Temperature	: 24 °C
Test Mode	: Mode 2, CH100 Band 3	Humidity	: 54 %
Test date	: Jul. 21, 2019	Atmospheric Pressure	: 1010 hpa

Frequency (MHz)	Factor (dB/m)	Reading (dBuV)	Level (dBuV/m)	Limit (dBuV/m)	Margin (dB)	Detector mode (PK/AVG)	AntPol. H/V
5460.000	1.99	40.25	42.24	74.00	-31.76	peak	H
5460.000	1.99	28.43	30.42	54.00	-23.58	AVG	H
5470.000	1.99	40.46	42.45	68.20	-25.75	peak	H
11000.000	14.67	36.69	51.36	74.00	-22.64	peak	H
11000.000	14.67	24.84	39.51	54.00	-14.49	AVG	H
16500.000	29.95	23.14	53.09	68.20	-15.11	peak	H
5460.000	1.99	57.36	59.35	74.00	-14.65	peak	V
5460.000	1.99	43.11	45.10	54.00	-8.90	AVG	V
5470.000	1.99	62.94	64.93	68.20	-3.27	peak	V
11000.000	14.67	38.43	53.10	74.00	-20.90	peak	V
11000.000	14.67	26.96	41.63	54.00	-12.37	AVG	V
16500.000	29.95	24.91	54.86	68.20	-13.34	peak	V

Note: Level = Reading + Factor
Margin = Level – Limit
Factor= Antenna Factor + Cable Loss - Amplifier Factor



Power	: DC 3.3V	Temperature	: 24 °C
Test Mode	: Mode 2, CH116 Band 3	Humidity	: 54 %
Test date	: Jul. 21, 2019	Atmospheric Pressure	: 1010 hpa

Frequency (MHz)	Factor (dB/m)	Reading (dBUV)	Level (dBUV/m)	Limit (dBUV/m)	Margin (dB)	Detector mode (PK/AVG)	AntPol. H/V
5460.000	1.99	39.58	41.57	74.00	-32.43	peak	H
5460.000	1.99	28.66	30.65	54.00	-23.35	AVG	H
5470.000	1.99	39.99	41.98	68.20	-26.22	peak	H
5725.000	2.58	39.34	41.92	68.20	-26.28	peak	H
11160.000	15.05	36.34	51.39	74.00	-22.61	peak	H
11160.000	15.05	24.77	39.82	54.00	-14.18	AVG	H
16740.000	29.65	23.56	53.21	68.20	-14.99	peak	H
5460.000	1.99	40.02	42.01	74.00	-31.99	peak	V
5460.000	1.99	28.60	30.59	54.00	-23.41	AVG	V
5470.000	1.99	39.74	41.73	68.20	-26.47	peak	V
5725.000	2.58	39.70	42.28	68.20	-25.92	peak	V
11160.000	15.05	37.41	52.46	74.00	-21.54	peak	V
11160.000	15.05	26.27	41.32	54.00	-12.68	AVG	V
16740.000	29.65	14.20	43.85	68.20	-24.35	peak	V

Note: Level = Reading + Factor
Margin = Level – Limit
Factor= Antenna Factor + Cable Loss - Amplifier Factor



Power	:	DC 3.3V	Temperature	:	24 °C
Test Mode	:	Mode 2, CH140 Band 3	Humidity	:	54 %
Test date	:	Jul. 21, 2019	Atmospheric Pressure	:	1010 hpa

Frequency (MHz)	Factor (dB/m)	Reading (dBuV)	Level (dBuV/m)	Limit (dBuV/m)	Margin (dB)	Detector mode (PK/AVG)	AntPol. H/V
5725.000	2.58	44.71	47.29	68.20	-20.91	peak	H
11400.000	15.62	35.52	51.14	74.00	-22.86	peak	H
11400.000	15.62	24.30	39.92	54.00	-14.08	AVG	H
17100.000	29.73	23.56	53.29	68.20	-14.91	peak	H
5725.000	2.58	63.77	66.35	68.20	-1.85	peak	V
11400.000	15.62	37.11	52.73	74.00	-21.27	peak	V
11400.000	15.62	25.17	40.79	54.00	-13.21	AVG	V
17100.000	29.73	24.85	54.58	68.20	-13.62	peak	V

Note: Level = Reading + Factor

Margin = Level – Limit

Factor= Antenna Factor + Cable Loss - Amplifier Factor



Power	:	DC 3.3V	Temperature	:	24 °C
Test Mode	:	Mode 2, CH149 Band 4	Humidity	:	54 %
Test date	:	Jul. 21, 2019	Atmospheric Pressure	:	1010 hpa

Frequency (MHz)	Factor (dB/m)	Reading (dBuV)	Level (dBuV/m)	Limit (dBuV/m)	Margin (dB)	Detector mode (PK/AVG)	AntPol. H/V
5650.000	2.39	39.37	41.76	68.20	-26.44	peak	H
5700.000	2.52	45.56	48.08	105.20	-57.12	peak	H
5720.000	2.57	63.17	65.74	110.80	-45.06	peak	H
5725.000	2.58	66.27	68.85	122.20	-53.35	peak	H
11490.000	15.84	35.63	51.47	74.00	-22.53	peak	H
11490.000	15.84	24.02	39.86	54.00	-14.14	AVG	H
17235.000	30.26	22.13	52.39	68.20	-15.81	peak	H
5650.000	2.39	40.87	43.26	68.20	-24.94	peak	V
5700.000	2.52	60.37	62.89	105.20	-42.31	peak	V
5720.000	2.57	70.80	73.37	110.80	-37.43	peak	V
5725.000	2.58	74.70	77.28	122.20	-44.92	peak	V
11490.000	15.84	37.13	52.97	74.00	-21.03	peak	V
11490.000	15.84	25.53	41.37	54.00	-12.63	AVG	V
17235.000	30.26	24.67	54.93	68.20	-13.27	peak	V

Note: Level = Reading + Factor
Margin = Level – Limit
Factor= Antenna Factor + Cable Loss - Amplifier Factor



Power	: DC 3.3V	Temperature	: 24 °C
Test Mode	: Mode 2, CH157 Band 4	Humidity	: 54 %
Test date	: Jul. 21, 2019	Atmospheric Pressure	: 1010 hpa

Frequency (MHz)	Factor (dB/m)	Reading (dBuV)	Level (dBuV/m)	Limit (dBuV/m)	Margin (dB)	Detector mode (PK/AVG)	AntPol. H/V
5650.000	2.39	39.29	41.68	68.20	-26.52	peak	H
5700.000	2.52	39.14	41.66	105.20	-63.54	peak	H
5720.000	2.57	39.21	41.78	110.80	-69.02	peak	H
5725.000	2.58	39.52	42.10	122.20	-80.10	peak	H
5850.000	2.89	39.00	41.89	122.20	-80.31	peak	H
5855.000	2.90	38.62	41.52	110.80	-69.28	peak	H
5875.000	2.95	38.51	41.46	105.20	-63.74	peak	H
5925.000	3.07	38.24	41.31	68.20	-26.89	peak	H
11570.000	16.00	34.83	50.83	74.00	-23.17	peak	H
11570.000	16.00	23.14	39.14	54.00	-14.86	AVG	H
17355.000	30.74	22.23	52.97	68.20	-15.23	peak	H
5650.000	2.39	39.50	41.89	68.20	-26.31	peak	V
5700.000	2.52	39.69	42.21	105.20	-62.99	peak	V
5700.000	2.52	39.34	41.86	105.20	-63.34	peak	V
5720.000	2.57	39.59	42.16	110.80	-68.64	peak	V
5725.000	2.58	39.25	41.83	122.20	-80.37	peak	V
5850.000	2.89	39.06	41.95	122.20	-80.25	peak	V
5875.000	2.95	38.80	41.75	105.20	-63.45	peak	V
5925.000	3.07	38.24	41.31	68.20	-26.89	peak	V
11570.000	16.00	36.87	52.87	74.00	-21.13	peak	V
11570.000	16.00	25.26	41.26	54.00	-12.74	AVG	V
17355.000	30.74	24.09	54.83	68.20	-13.37	peak	V

Note: Level = Reading + Factor
Margin = Level – Limit
Factor= Antenna Factor + Cable Loss - Amplifier Factor



Power	: DC 3.3V	Temperature	: 24 °C
Test Mode	: Mode 2, CH165 Band4	Humidity	: 54 %
Test date	: Jul. 21, 2019	Atmospheric Pressure	: 1010 hpa

Frequency (MHz)	Factor (dB/m)	Reading (dBuV)	Level (dBuV/m)	Limit (dBuV/m)	Margin (dB)	Detector mode (PK/AVG)	AntPol. H/V
5850.000	2.89	53.21	56.10	122.20	-66.10	peak	H
5855.000	2.90	47.62	50.52	110.80	-60.28	peak	H
5875.000	2.95	38.42	41.37	105.20	-63.83	peak	H
5925.000	3.07	38.72	41.79	68.20	-26.41	peak	H
11650.000	16.16	35.15	51.31	74.00	-22.69	peak	H
11650.000	16.16	23.60	39.76	54.00	-14.24	AVG	H
17475.000	31.21	21.96	53.17	68.20	-15.03	peak	H
5850.000	2.89	68.73	71.62	122.20	-50.58	peak	V
5855.000	2.90	66.64	69.54	110.80	-41.26	peak	V
5875.000	2.95	52.44	55.39	105.20	-49.81	peak	V
5925.000	3.07	38.45	41.52	68.20	-26.68	peak	V
11650.000	16.16	36.53	52.69	74.00	-21.31	peak	V
11650.000	16.16	24.42	40.58	54.00	-13.42	AVG	V
17475.000	31.21	23.74	54.95	68.20	-13.25	peak	V

Note: Level = Reading + Factor
Margin = Level – Limit
Factor= Antenna Factor + Cable Loss - Amplifier Factor



Power	: DC 3.3V	Temperature	: 24 °C
Test Mode	: Mode 3, CH38 Band 1	Humidity	: 54 %
Test date	: Jul. 21, 2019	Atmospheric Pressure	: 1010 hpa

Frequency (MHz)	Factor (dB/m)	Reading (dBuV)	Level (dBuV/m)	Limit (dBuV/m)	Margin (dB)	Detector mode (PK/AVG)	AntPol. H/V
5150.000	1.73	47.09	48.82	74.00	-25.18	peak	H
5150.000	1.73	34.65	36.38	54.00	-17.62	AVG	H
10380.000	12.89	37.57	50.46	68.20	-17.74	peak	H
15570.000	25.26	27.92	53.18	74.00	-20.82	peak	H
15570.000	25.26	17.48	42.74	54.00	-11.26	AVG	H
5150.000	1.73	61.53	63.26	74.00	-10.74	peak	V
5150.000	1.73	49.38	51.11	54.00	-2.89	AVG	V
10380.000	12.89	39.54	52.43	68.20	-15.77	peak	V
15570.000	25.26	29.63	54.89	74.00	-19.11	peak	V
15570.000	25.26	19.35	44.61	54.00	-9.39	AVG	V

Note: Level = Reading + Factor

Margin = Level – Limit

Factor= Antenna Factor + Cable Loss - Amplifier Factor



Power	: DC 3.3V	Temperature	: 24 °C
Test Mode	: Mode 3, CH46 Band 1	Humidity	: 54 %
Test date	: Jul. 21, 2019	Atmospheric Pressure	: 1010 hpa

Frequency (MHz)	Factor (dB/m)	Reading (dBuV)	Level (dBuV/m)	Limit (dBuV/m)	Margin (dB)	Detector mode (PK/AVG)	AntPol. H/V
5350.000	1.89	40.74	42.63	74.00	-31.37	peak	H
5350.000	1.89	28.55	30.44	54.00	-23.56	AVG	H
10460.000	13.07	37.74	50.81	68.20	-17.39	peak	H
15690.000	25.32	28.03	53.35	74.00	-20.65	peak	H
15690.000	25.32	17.05	42.37	54.00	-11.63	AVG	H
5350.000	1.89	42.87	44.76	74.00	-29.24	peak	V
5350.000	1.89	30.26	32.15	54.00	-21.85	AVG	V
10460.000	13.07	39.27	52.34	68.20	-15.86	peak	V
15690.000	25.32	29.35	54.67	74.00	-19.33	peak	V
15690.000	25.32	18.96	44.28	54.00	-9.72	AVG	V

Note: Level = Reading + Factor

Margin = Level – Limit

Factor= Antenna Factor + Cable Loss - Amplifier Factor



Power	: DC 3.3V	Temperature	: 24 °C
Test Mode	: Mode 3, CH54 Band 2	Humidity	: 54 %
Test date	: Jul. 21, 2019	Atmospheric Pressure	: 1010 hpa

Frequency (MHz)	Factor (dB/m)	Reading (dBuV)	Level (dBuV/m)	Limit (dBuV/m)	Margin (dB)	Detector mode (PK/AVG)	AntPol. H/V
5350.000	1.89	39.82	41.71	74.00	-32.29	peak	H
5350.000	1.89	28.48	30.37	54.00	-23.63	AVG	H
10540.000	13.28	37.75	51.03	68.20	-17.17	peak	H
15810.000	25.37	27.74	53.11	74.00	-20.89	peak	H
15810.000	25.37	16.57	41.94	54.00	-12.06	AVG	H
5350.000	1.89	53.42	55.31	74.00	-18.69	peak	V
5350.000	1.89	40.79	42.68	54.00	-11.32	AVG	V
10540.000	13.28	38.14	51.42	68.20	-16.78	peak	V
15810.000	25.37	29.02	54.39	74.00	-19.61	peak	V
15810.000	25.37	18.41	43.78	54.00	-10.22	AVG	V

Note: Level = Reading + Factor

Margin = Level – Limit

Factor= Antenna Factor + Cable Loss - Amplifier Factor



Power	: DC 3.3V	Temperature	: 24 °C
Test Mode	: Mode 3, CH62 Band 2	Humidity	: 54 %
Test date	: Jul. 21, 2019	Atmospheric Pressure	: 1010 hpa

Frequency (MHz)	Factor (dB/m)	Reading (dBuV)	Level (dBuV/m)	Limit (dBuV/m)	Margin (dB)	Detector mode (PK/AVG)	AntPol. H/V
5350.000	1.89	56.57	58.46	74.00	-15.54	peak	H
5350.000	1.89	43.43	45.32	54.00	-8.68	AVG	H
10620.000	13.52	37.83	51.35	74.00	-22.65	peak	H
15930.000	25.43	27.88	53.31	74.00	-20.69	peak	H
15930.000	25.43	16.35	41.78	54.00	-12.22	AVG	H
5350.000	1.89	62.49	64.38	74.00	-9.62	peak	V
5350.000	1.89	49.25	51.14	54.00	-2.86	AVG	V
10620.000	13.52	38.85	52.37	74.00	-21.63	peak	V
15930.000	25.43	28.93	54.36	74.00	-19.64	peak	V
15930.000	25.43	18.09	43.52	54.00	-10.48	AVG	V

Note: Level = Reading + Factor

Margin = Level – Limit

Factor= Antenna Factor + Cable Loss - Amplifier Factor



Power	:	DC 3.3V	Temperature	:	24 °C
Test Mode	:	Mode 3, CH102 Band 3	Humidity	:	54 %
Test date	:	Jul. 21, 2019	Atmospheric Pressure	:	1010 hpa

Frequency (MHz)	Factor (dB/m)	Reading (dBuV)	Level (dBuV/m)	Limit (dBuV/m)	Margin (dB)	Detector mode (PK/AVG)	AntPol. H/V
5460.000	1.99	43.65	45.64	74.00	-28.36	peak	H
5460.000	1.99	30.96	32.95	54.00	-21.05	AVG	H
5470.000	1.99	54.39	56.38	68.20	-11.82	peak	H
11020.000	14.72	36.17	50.89	74.00	-23.11	peak	H
11020.000	14.72	23.52	38.24	54.00	-15.76	AVG	H
16530.000	29.91	23.74	53.65	68.20	-14.55	peak	H
5460.000	1.99	51.88	53.87	74.00	-20.13	peak	V
5460.000	1.99	43.67	45.66	54.00	-8.34	AVG	V
5470.000	1.99	61.58	63.57	68.20	-4.63	peak	V
11020.000	14.72	37.44	52.16	74.00	-21.84	peak	V
11020.000	14.72	26.10	40.82	54.00	-13.18	AVG	V
16530.000	29.91	21.72	51.63	68.20	-16.57	peak	V

Note: Level = Reading + Factor
Margin = Level – Limit
Factor= Antenna Factor + Cable Loss - Amplifier Factor



Power	:	DC 3.3V	Temperature	:	24 °C
Test Mode	:	Mode 3, CH110 Band 3	Humidity	:	54 %
Test date	:	Jul. 21, 2019	Atmospheric Pressure	:	1010 hpa

Frequency (MHz)	Factor (dB/m)	Reading (dBuV)	Level (dBuV/m)	Limit (dBuV/m)	Margin (dB)	Detector mode (PK/AVG)	AntPol. H/V
5460.000	1.99	39.04	41.03	74.00	-32.97	peak	H
5460.000	1.99	28.34	30.33	54.00	-23.67	AVG	H
5470.000	1.99	39.96	41.95	68.20	-26.25	peak	H
5725.000	2.58	39.77	42.35	68.20	-25.85	peak	H
11000.000	14.67	36.59	51.26	74.00	-22.74	peak	H
11000.000	14.67	25.14	39.81	54.00	-14.19	AVG	H
16650.000	29.76	23.23	52.99	68.20	-15.21	peak	H
5460.000	1.99	46.51	48.50	74.00	-25.50	peak	V
5460.000	1.99	33.66	35.65	54.00	-18.35	AVG	V
5470.000	1.99	48.65	50.64	68.20	-17.56	peak	V
5725.000	2.58	39.70	42.28	68.20	-25.92	peak	V
11100.000	14.91	37.58	52.49	74.00	-21.51	peak	V
11100.000	14.91	26.28	41.19	54.00	-12.81	AVG	V
16650.000	29.76	25.01	54.77	68.20	-13.43	peak	V

Note: Level = Reading + Factor
Margin = Level – Limit
Factor= Antenna Factor + Cable Loss - Amplifier Factor



Power	: DC 3.3V	Temperature	: 24 °C
Test Mode	: Mode 3, CH134 Band 3	Humidity	: 54 %
Test date	: Jul. 21, 2019	Atmospheric Pressure	: 1010 hpa

Frequency (MHz)	Factor (dB/m)	Reading (dBuV)	Level (dBuV/m)	Limit (dBuV/m)	Margin (dB)	Detector mode (PK/AVG)	AntPol. H/V
5725.000	2.58	40.08	42.66	68.20	-25.54	peak	H
11340.000	15.48	35.75	51.23	74.00	-22.77	peak	H
11340.000	15.48	24.19	39.67	54.00	-14.33	AVG	H
17010.000	29.37	23.87	53.24	68.20	-14.96	peak	H
5725.000	2.58	56.05	58.63	68.20	-9.57	peak	V
11340.000	15.48	37.24	52.72	74.00	-21.28	peak	V
11340.000	15.48	25.28	40.76	54.00	-13.24	AVG	V
17010.000	29.37	25.25	54.62	68.20	-13.58	peak	V

Note: Level = Reading + Factor

Margin = Level – Limit

Factor= Antenna Factor + Cable Loss - Amplifier Factor



Power	:	DC 3.3V	Temperature	:	24 °C
Test Mode	:	Mode 3, CH151 Band 4	Humidity	:	54 %
Test date	:	Jul. 21, 2019	Atmospheric Pressure	:	1010 hpa

Frequency (MHz)	Factor (dB/m)	Reading (dBuV)	Level (dBuV/m)	Limit (dBuV/m)	Margin (dB)	Detector mode (PK/AVG)	AntPol. H/V
5650.000	2.39	38.56	40.95	68.20	-27.25	peak	H
5700.000	2.52	46.39	48.91	105.20	-56.29	peak	H
5720.000	2.57	59.49	62.06	110.80	-48.74	peak	H
5725.000	2.58	63.15	65.73	122.20	-56.47	peak	H
11510.000	15.88	35.90	51.78	74.00	-22.22	peak	H
11510.000	15.88	24.29	40.17	54.00	-13.83	AVG	H
17625.000	32.74	21.07	53.81	68.20	-14.39	peak	H
5650.000	2.39	43.18	45.57	68.20	-22.63	peak	V
5700.000	2.52	60.20	62.72	105.20	-42.48	peak	V
5720.000	2.57	69.75	72.32	110.80	-38.48	peak	V
5725.000	2.58	71.48	74.06	122.20	-48.14	peak	V
11510.000	15.88	36.79	52.67	74.00	-21.33	peak	V
11510.000	15.88	25.90	41.78	54.00	-12.22	AVG	V
17265.000	30.38	24.55	54.93	68.20	-13.27	peak	V

Note: Level = Reading + Factor
Margin = Level – Limit
Factor= Antenna Factor + Cable Loss - Amplifier Factor



Power	: DC 3.3V	Temperature	: 24 °C
Test Mode	: Mode 3, CH159 Band 4	Humidity	: 54 %
Test date	: Jul. 21, 2019	Atmospheric Pressure	: 1010 hpa

Frequency (MHz)	Factor (dB/m)	Reading (dBuV)	Level (dBuV/m)	Limit (dBuV/m)	Margin (dB)	Detector mode (PK/AVG)	AntPol. H/V
5850.000	2.89	40.88	43.77	122.20	-78.43	peak	H
5855.000	2.90	40.10	43.00	110.80	-67.80	peak	H
5875.000	2.95	39.49	42.44	105.20	-62.76	peak	H
5925.000	3.07	38.36	41.43	68.20	-26.77	peak	H
11590.000	16.04	35.39	51.43	74.00	-22.57	peak	H
11590.000	16.04	23.81	39.85	54.00	-14.15	AVG	H
17385.000	30.85	23.08	53.93	68.20	-14.27	peak	H
5850.000	2.89	61.70	64.59	122.20	-57.61	peak	V
5855.000	2.90	57.93	60.83	110.80	-49.97	peak	V
5875.000	2.95	53.65	56.60	105.20	-48.60	peak	V
5925.000	3.07	38.65	41.72	68.20	-26.48	peak	V
11590.000	16.04	37.38	53.42	74.00	-20.58	peak	V
11590.000	16.04	26.25	42.29	54.00	-11.71	AVG	V
17385.000	30.85	24.56	55.41	68.20	-12.79	peak	V

Note: Level = Reading + Factor
Margin = Level – Limit
Factor= Antenna Factor + Cable Loss - Amplifier Factor



Power	: DC 3.3V	Temperature	: 24 °C
Test Mode	: Mode 4, CH42 Band 1	Humidity	: 54 %
Test date	: Jul. 21, 2019	Atmospheric Pressure	: 1010 hpa

Frequency (MHz)	Factor (dB/m)	Reading (dBuV)	Level (dBuV/m)	Limit (dBuV/m)	Margin (dB)	Detector mode (PK/AVG)	AntPol. H/V
5150.000	1.73	53.65	55.38	74.00	-18.62	peak	H
5150.000	1.73	42.74	44.47	54.00	-9.53	AVG	H
5350.000	1.89	41.23	43.12	74.00	-30.88	peak	H
5350.000	1.89	28.76	30.65	54.00	-23.35	AVG	H
10420.000	12.98	38.36	51.34	68.20	-16.86	peak	H
15630.000	25.29	28.45	53.74	74.00	-20.26	peak	H
15630.000	25.29	16.36	41.65	54.00	-12.35	AVG	H
5150.000	1.73	61.02	62.75	74.00	-11.25	peak	V
5150.000	1.73	49.59	51.32	54.00	-2.68	AVG	V
5350.000	1.89	47.23	49.12	74.00	-24.88	peak	V
5350.000	1.89	34.89	36.78	54.00	-17.22	AVG	V
10420.000	12.98	39.86	52.84	68.20	-15.36	peak	V
15630.000	25.29	29.38	54.67	74.00	-19.33	peak	V
15630.000	25.29	18.96	44.25	54.00	-9.75	AVG	V

Note: Level = Reading + Factor
Margin = Level – Limit
Factor= Antenna Factor + Cable Loss - Amplifier Factor



Power	: DC 3.3V	Temperature	: 24 °C
Test Mode	: Mode 4, CH58 Band 2	Humidity	: 54 %
Test date	: Jul. 21, 2019	Atmospheric Pressure	: 1010 hpa

Frequency (MHz)	Factor (dB/m)	Reading (dBuV)	Level (dBuV/m)	Limit (dBuV/m)	Margin (dB)	Detector mode (PK/AVG)	AntPol. H/V
5150.000	1.73	40.61	42.34	74.00	-31.66	peak	H
5150.000	1.73	28.37	30.10	54.00	-23.90	AVG	H
5350.000	1.89	52.46	54.35	74.00	-19.65	peak	H
5350.000	1.89	40.74	42.63	54.00	-11.37	AVG	H
10580.000	13.40	38.27	51.67	68.20	-16.53	peak	H
15870.000	25.40	27.88	53.28	74.00	-20.72	peak	H
15870.000	25.40	16.22	41.62	54.00	-12.38	AVG	H
5150.000	1.73	45.80	47.53	74.00	-26.47	peak	V
5150.000	1.73	32.53	34.26	54.00	-19.74	AVG	V
5350.000	1.89	61.68	63.57	74.00	-10.43	peak	V
5350.000	1.89	49.53	51.42	54.00	-2.58	AVG	V
10580.000	13.40	39.07	52.47	68.20	-15.73	peak	V
15870.000	25.40	29.56	54.96	74.00	-19.04	peak	V
15870.000	25.40	18.89	44.29	54.00	-9.71	AVG	V

Note: Level = Reading + Factor
Margin = Level – Limit
Factor= Antenna Factor + Cable Loss - Amplifier Factor



Power	:	DC 3.3V	Temperature	:	24 °C
Test Mode	:	Mode 4, CH106 band 3	Humidity	:	54 %
Test date	:	Jul. 21, 2019	Atmospheric Pressure	:	1010 hpa

Frequency (MHz)	Factor (dB/m)	Reading (dBuV)	Level (dBuV/m)	Limit (dBuV/m)	Margin (dB)	Detector mode (PK/AVG)	AntPol. H/V
5460.000	1.99	48.68	50.67	74.00	-23.33	peak	H
5460.000	1.99	35.87	37.86	54.00	-16.14	AVG	H
5470.000	1.99	49.58	51.57	68.20	-16.63	peak	H
5725.000	2.58	39.98	42.56	68.20	-25.64	peak	H
11060.000	14.81	36.81	51.62	74.00	-22.38	peak	H
11060.000	14.81	24.41	39.22	54.00	-14.78	AVG	H
16590.000	29.84	23.87	53.71	68.20	-14.49	peak	H
5460.000	1.99	59.39	61.38	74.00	-12.62	peak	V
5460.000	1.99	48.64	50.63	54.00	-3.37	AVG	V
5470.000	1.99	60.54	62.53	68.20	-5.67	peak	V
5725.000	2.58	27.94	30.52	68.20	-37.68	peak	V
11060.000	14.81	37.88	52.69	74.00	-21.31	peak	V
11060.000	14.81	25.81	40.62	54.00	-13.38	AVG	V
16590.000	29.84	25.37	55.21	68.20	-12.99	peak	V

Note: Level = Reading + Factor
Margin = Level – Limit
Factor= Antenna Factor + Cable Loss - Amplifier Factor



Power	: DC 3.3V	Temperature	: 24 °C
Test Mode	: Mode 4, CH122 Band3	Humidity	: 54 %
Test date	: Jul. 21, 2019	Atmospheric Pressure	: 1010 hpa

Frequency (MHz)	Factor (dB/m)	Reading (dBuV)	Level (dBuV/m)	Limit (dBuV/m)	Margin (dB)	Detector mode (PK/AVG)	AntPol. H/V
5460.000	1.99	40.55	42.54	74.00	-31.46	peak	H
5460.000	1.99	28.38	30.37	54.00	-23.63	AVG	H
5470.000	1.99	39.57	41.56	68.20	-26.64	peak	H
5725.000	2.58	39.57	42.15	68.20	-26.05	peak	H
11220.000	15.19	36.76	51.95	74.00	-22.05	peak	H
11220.000	15.19	24.07	39.26	54.00	-14.74	AVG	H
16830.000	29.54	23.90	53.44	68.20	-14.76	peak	H
5460.000	1.99	47.54	49.53	74.00	-24.47	peak	V
5460.000	1.99	34.58	36.57	54.00	-17.43	AVG	V
5470.000	1.99	50.69	52.68	68.20	-15.52	peak	V
5725.000	2.58	53.05	55.63	68.20	-12.57	peak	V
11220.000	15.19	37.48	52.67	74.00	-21.33	peak	V
11220.000	15.19	25.12	40.31	54.00	-13.69	AVG	V
16830.000	29.54	25.37	54.91	68.20	-13.29	peak	V

Note: Level = Reading + Factor
Margin = Level – Limit
Factor= Antenna Factor + Cable Loss - Amplifier Factor



Power	: DC 3.3V	Temperature	: 24 °C
Test Mode	: Mode 4, CH155 Band4	Humidity	: 54 %
Test date	: Jul. 21, 2019	Atmospheric Pressure	: 1010 hpa

Frequency (MHz)	Factor (dB/m)	Reading (dBuV)	Level (dBuV/m)	Limit (dBuV/m)	Margin (dB)	Detector mode (PK/AVG)	AntPol. H/V
5650.000	2.39	43.00	45.39	68.20	-22.81	peak	H
5700.000	2.52	59.10	61.62	105.20	-43.58	peak	H
5720.000	2.57	61.73	64.30	110.80	-46.50	peak	H
5725.000	2.58	62.76	65.34	122.20	-56.86	peak	H
5850.000	2.89	58.97	61.86	122.20	-60.34	peak	H
5855.000	2.90	58.44	61.34	110.80	-49.46	peak	H
5875.000	2.95	52.60	55.55	105.20	-49.65	peak	H
5925.000	3.07	39.93	43.00	68.20	-25.20	peak	H
11550.000	15.96	35.20	51.16	74.00	-22.84	peak	H
11550.000	15.96	23.25	39.21	54.00	-14.79	AVG	H
17325.000	30.62	23.22	53.84	68.20	-14.36	peak	H
5650.000	2.39	53.84	56.23	68.20	-11.97	peak	V
5700.000	2.52	65.15	67.67	105.20	-37.53	peak	V
5700.000	2.52	67.90	70.42	105.20	-34.78	peak	V
5720.000	2.57	69.30	71.87	110.80	-38.93	peak	V
5725.000	2.58	66.64	69.22	122.20	-52.98	peak	V
5850.000	2.89	65.50	68.39	122.20	-53.81	peak	V
5875.000	2.95	59.72	62.67	105.20	-42.53	peak	V
5925.000	3.07	50.18	53.25	68.20	-14.95	peak	V
11550.000	15.96	37.45	53.41	74.00	-20.59	peak	V
11550.000	15.96	25.42	41.38	54.00	-12.62	AVG	V
17325.000	30.62	24.72	55.34	68.20	-12.86	peak	V

Note: Level = Reading + Factor
Margin = Level – Limit
Factor= Antenna Factor + Cable Loss - Amplifier Factor



6.7. Restricted Bands of Operation

Only spurious emissions are permitted in any of the frequency bands listed below:

MHz	MHz	MHz	GHz
0.09000 – 0.11000	16.42000 – 16.42300	399.9 – 410.0	4.500 – 5.150
0.49500 – 0.505**	16.69475 – 16.69525	608.0 – 614.0	5.350 – 5.460
2.17350 – 2.19050	16.80425 – 16.80475	960.0 – 1240.0	7.250 – 7.750
4.12500 – 4.12800	25.50000 – 25.67000	1300.0 – 1427.0	8.025 – 8.500
4.17725 – 4.17775	37.50000 – 38.25000	1435.0 – 1626.5	9.000 – 9.200
4.20725 – 4.20775	73.00000 – 74.60000	1645.5 – 1646.5	9.300 – 9.500
6.21500 – 6.21800	74.80000 – 75.20000	1660.0 – 1710.0	10.600 – 12.700
6.26775 – 6.26825	108.00000 – 121.94000	1718.8 – 1722.2	13.250 – 13.400
6.31175 – 6.31225	123.00000 – 138.00000	2200.0 – 2300.0	14.470 – 14.500
8.29100 – 8.29400	149.90000 – 150.05000	2310.0 – 2390.0	15.350 – 16.200
8.36200 – 8.36600	156.52475 – 156.52525	2483.5 – 2500.0	17.700 – 21.400
8.37625 – 8.38675	156.70000 – 156.90000	2655.0 – 2900.0	22.010 – 23.120
8.41425 – 8.41475	162.01250 – 167.17000	3260.0 – 3267.0	23.600 – 24.000
12.29000 – 12.29300	167.72000 – 173.20000	3332.0 – 3339.0	31.200 – 31.800
12.51975 – 12.52025	240.00000 – 285.00000	3345.8 – 3358.0	36.430 – 36.500
12.57675 – 12.57725	322.00000 – 335.40000	3600.0 – 4400.0	Above 38.6
13.36000 – 13.41000			

** : Until February 1, 1999, this restricted band shall be 0.490-0.510 MHz



7. On Time, Duty Cycle and Measurement methods

7.1. Test Limit

None; for reporting purposes only.

7.2. Test Procedure

KDB 789033 Zero-Span Spectrum Analyzer Method.

7.3. Test Setup Layout

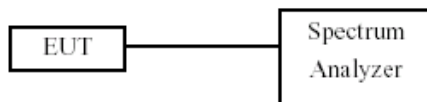

7.4. Test Result and Data

Temperature: 21°C

Humidity: 56%

Test Date: Jul. 21, 2019

Modulation Type	On Time (msec)	Period Time (msec)	Duty Cycle (%)	1/T Minimum VBW(Hz)	Duty Cycle correction Factor (dB)
802.11a	100.00	100.00	100.00%	10.00	0.00
802.11n HT20	100.00	100.00	100.00%	10.00	0.00
802.11n HT40	100.00	100.00	100.00%	10.00	0.00
802.11ac VHT20	100.00	100.00	100.00%	10.00	0.00
802.11ac VHT40	100.00	100.00	100.00%	10.00	0.00
802.11ac VHT80	100.00	100.00	100.00%	10.00	0.00

7.5. Measurement Methods

26 dB and 6dB Emission BW	KDB 789033 D02 v02r01, Section C
99% Occupied BW	KDB 789033 D02 v02r01, Section D
Conducted Output Power	KDB 789033 D02 v02r01, Section E.2.d and E.3.b (Method PM-G)
Power Spectral Density	KDB 789033 D02 v02r01, Section F
Unwanted emissions in restricted bands	KDB 789033 D02 v02r01, Sections G and H
Unwanted emissions in non-restricted bands	KDB 789033 D02 v02r01, Sections G and H



Modulation Standard: 802.11a (6Mbps)



Modulation Standard: 802.11n HT20 (6.5Mbps)

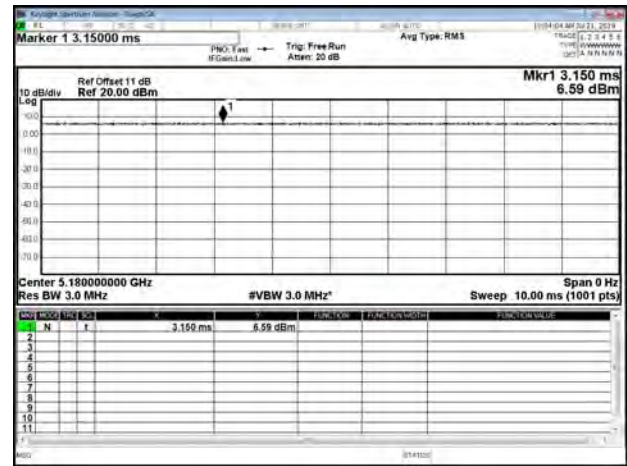

Modulation Standard: 802.11n HT40 (13.5Mbps)

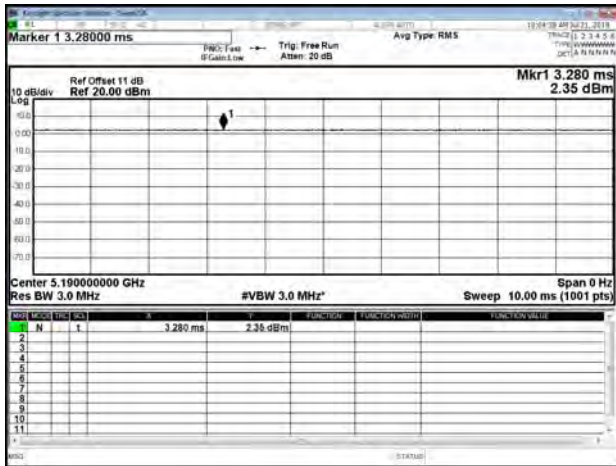

Modulation Standard: 802.11ac VHT20 (29.3Mbps)

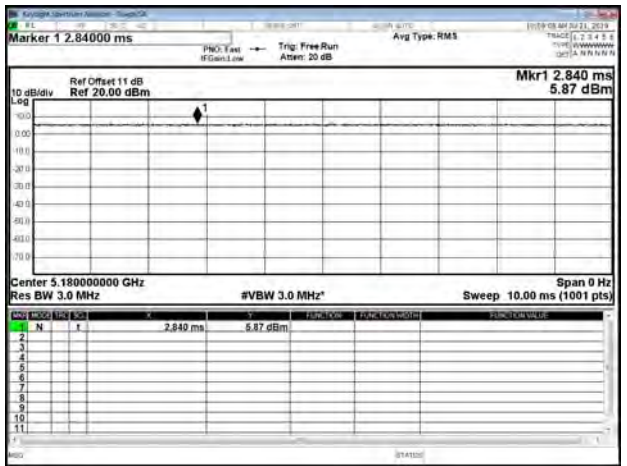

Modulation Standard: 802.11ac VHT40 (13.5Mbps)

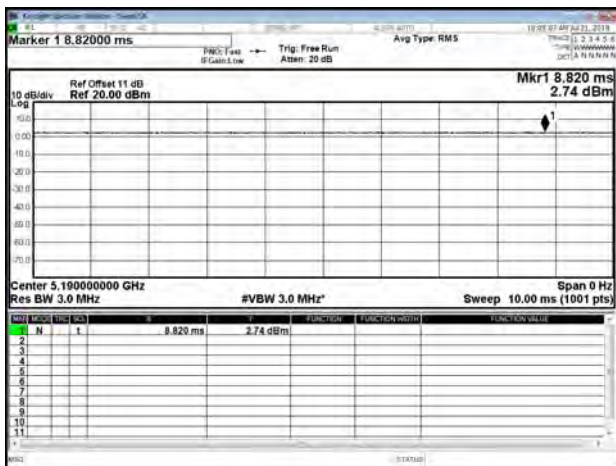

Modulation Standard: 802.11ac VHT80 (29.3Mbps)

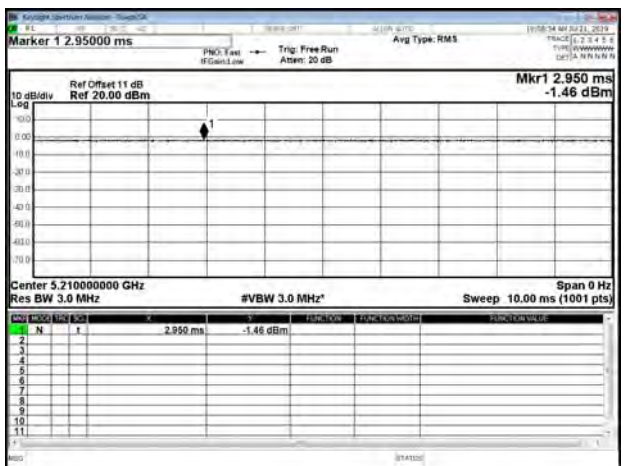



8. 6dB Bandwidth & 99% Bandwidth

8.1. Test Limit

FCC §15.407

The minimum 6 dB bandwidth shall be at least 500 kHz.

8.2. Test Procedure

Reference to 789033 D02 General UNII Test Procedures New Rules v01: The transmitter output is connected to a spectrum analyzer with the RBW set to 100KHz, the VBW $\geq 3 \times$ RBW, peak detector and max hold.

8.3. Test Setup Layout

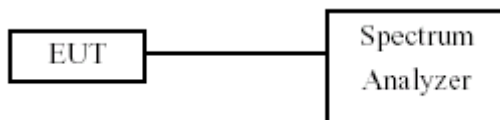



8.4. Test Result and Data (6dB Bandwidth)

Temperature: 21°C

Humidity: 56%

Test Date: Jul. 21, 2019

In the 5.8G Band

Modulation Type	Channel	Frequency (MHz)	6dB Bandwidth (MHz)		Minimum Limit (MHz)
			Chain 1	Chain 2	
802.11a	149	5745	16.55	16.51	0.50
	157	5785	16.53	16.51	0.50
	165	5825	16.53	16.52	0.50
802.11ac VHT20	149	5745	17.71	17.74	0.50
	157	5785	17.75	17.75	0.50
	165	5825	17.76	17.74	0.50
802.11ac VHT40	155	5755	36.47	36.44	0.50
	159	5795	36.46	36.46	0.50
802.11ac VHT80	155	5775	76.49	76.42	0.50



8.5. Test Result and Data (99% Bandwidth)

Temperature: 21°C

Humidity: 56%

Test Date: Jul. 21, 2019

In the 5.8G Band

Modulation Type	Channel	Frequency (MHz)	99% Bandwidth (MHz)	
			Chain 1	Chain 2
802.11a	149	5745	16.41	16.39
	157	5785	16.40	16.40
	165	5825	16.41	16.40
802.11ac VHT20	149	5745	17.59	17.58
	157	5785	17.59	17.59
	165	5825	17.60	17.58
802.11ac VHT40	155	5755	36.19	36.13
	159	5795	36.13	36.07
802.11ac VHT80	155	5775	75.27	75.15



6dB Bandwidth
Chain 1
Modulation Standard: 802.11a
CH149

Modulation Standard: 802.11ac,VHT20
CH149

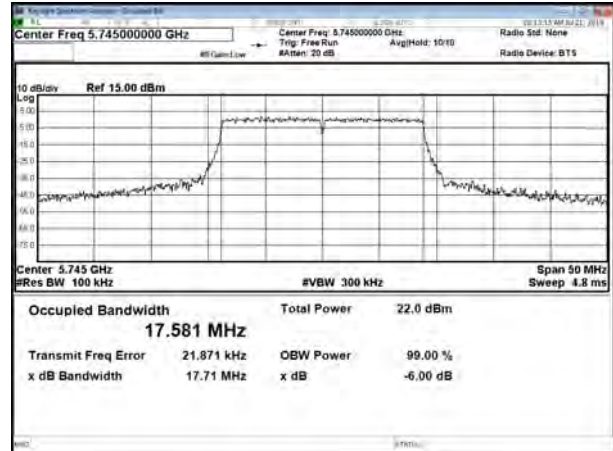
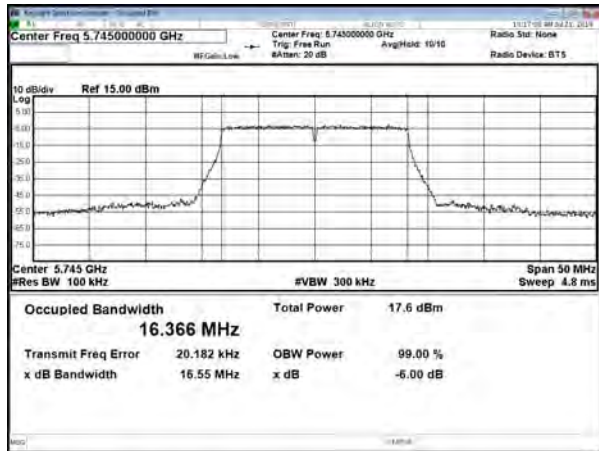

CH157

CH157

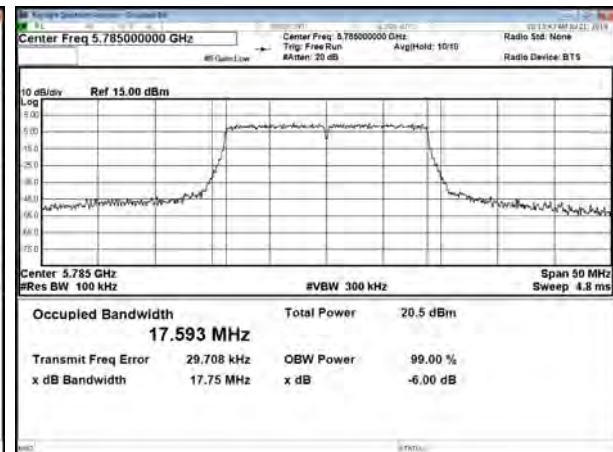
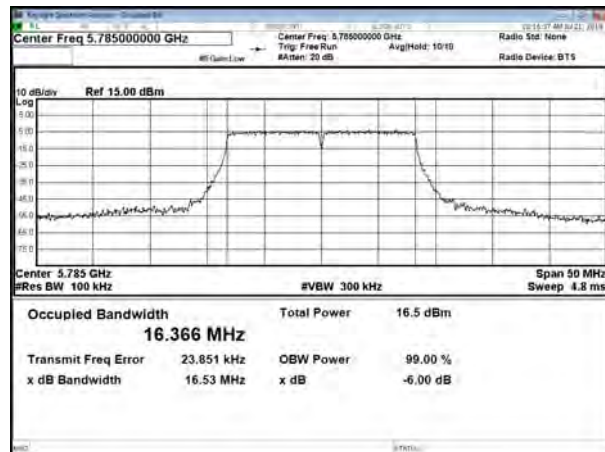

CH165

CH165

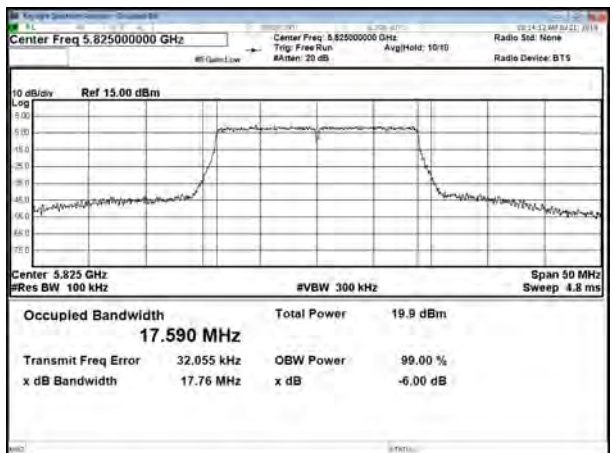
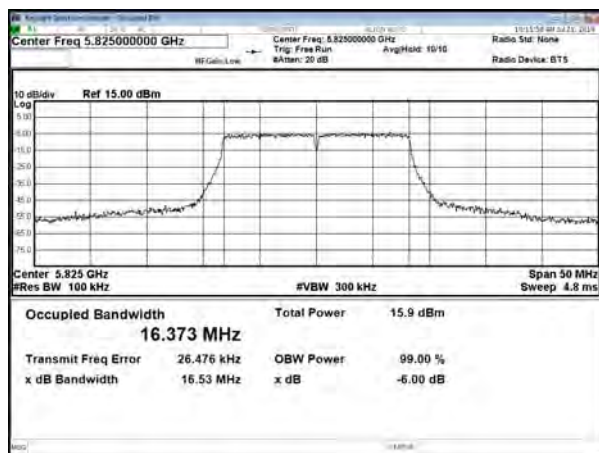



Modulation Standard: 802.11ac,VHT20
CH151

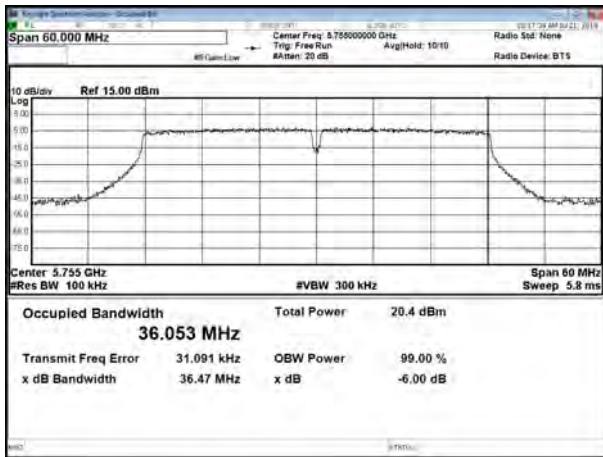

Chain 2
Modulation Standard: 802.11a
CH149

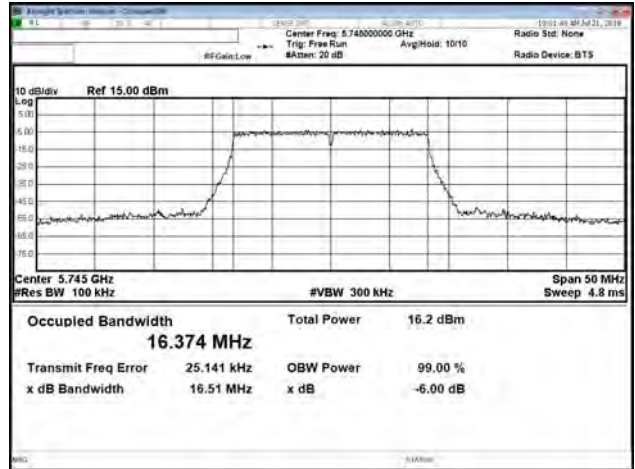

CH159

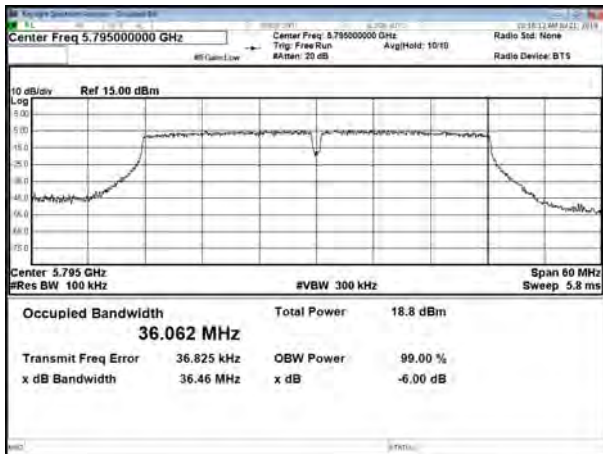

CH157

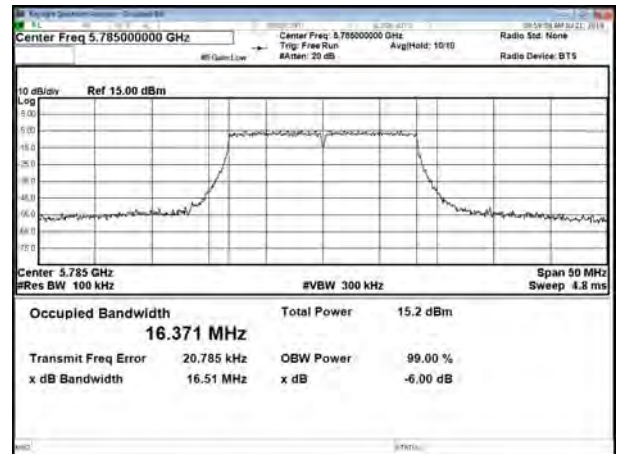

Modulation Standard: 802.11ac,VHT80
CH155

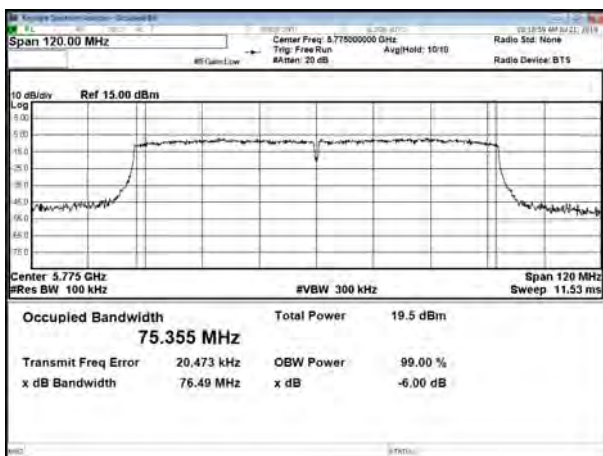

CH165

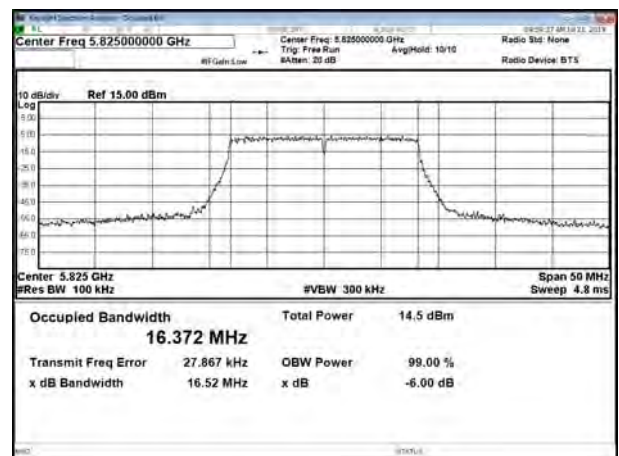



Modulation Standard: 802.11ac,VHT20
CH149

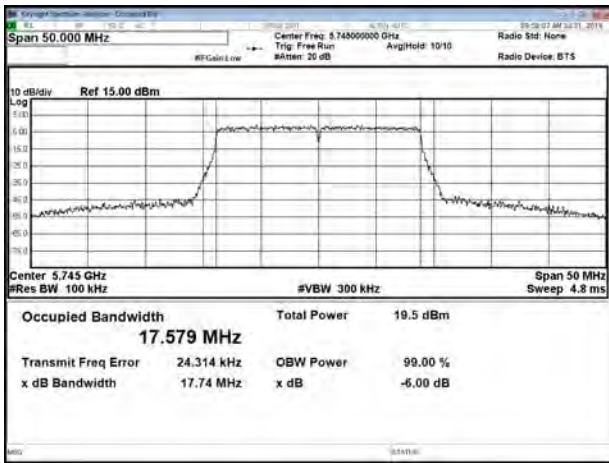

Modulation Standard: 802.11ac,VHT40
CH151

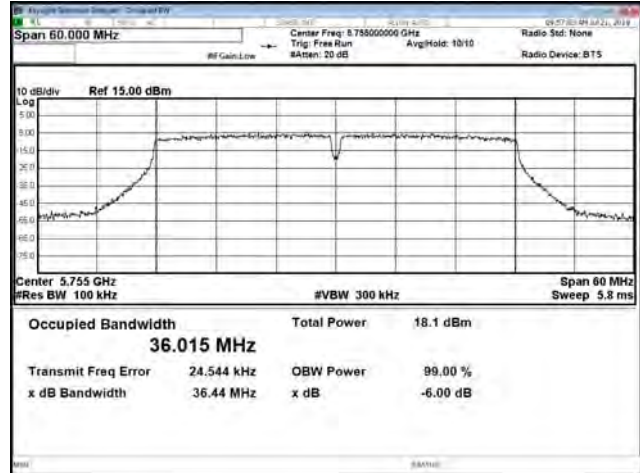

CH157

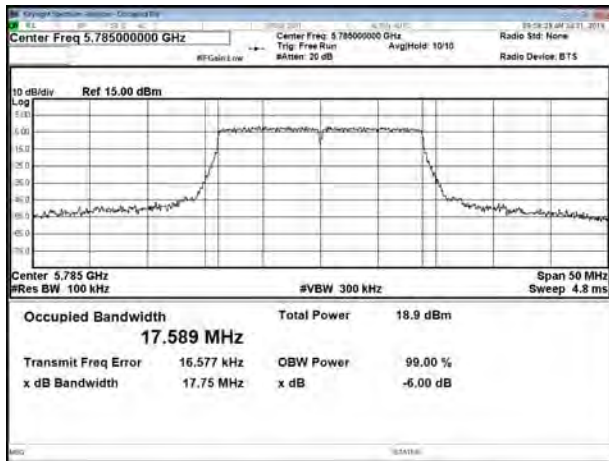

CH159



Modulation Standard: 802.11ac,VHT80

CH165

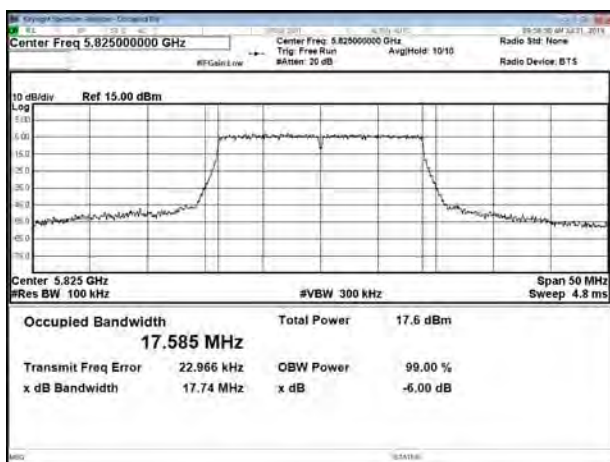

CH155

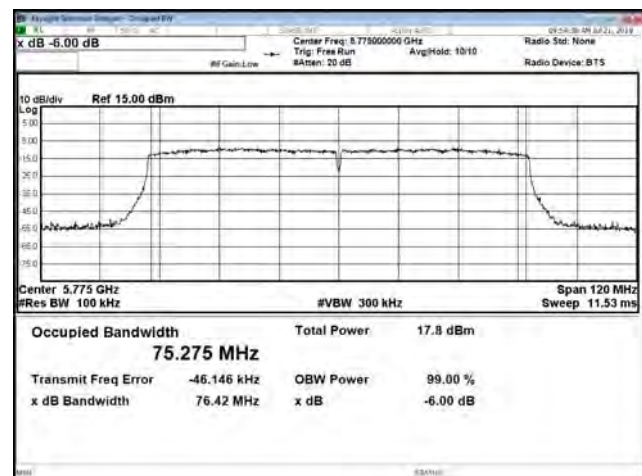



99% Bandwidth
Chain 1
Modulation Standard: 802.11a
CH149

Modulation Standard: 802.11ac,VHT20
CH149

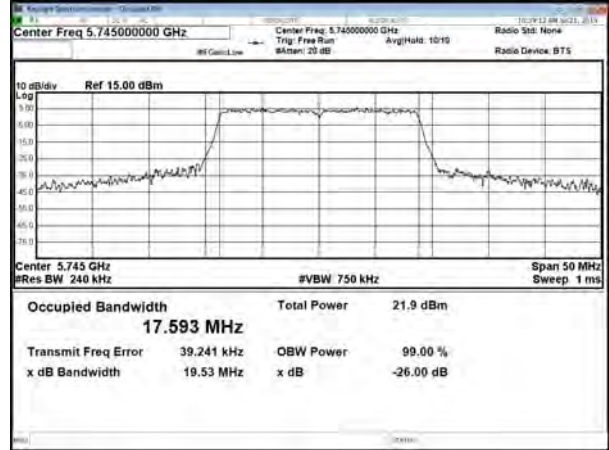
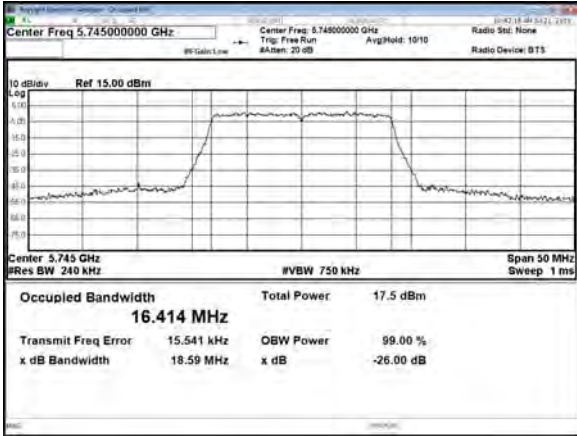

CH157

CH157

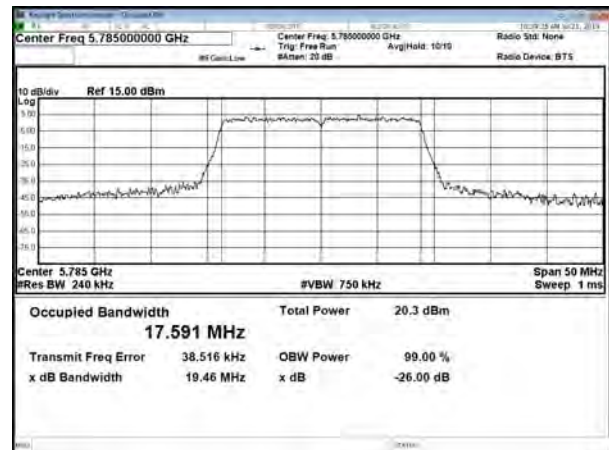
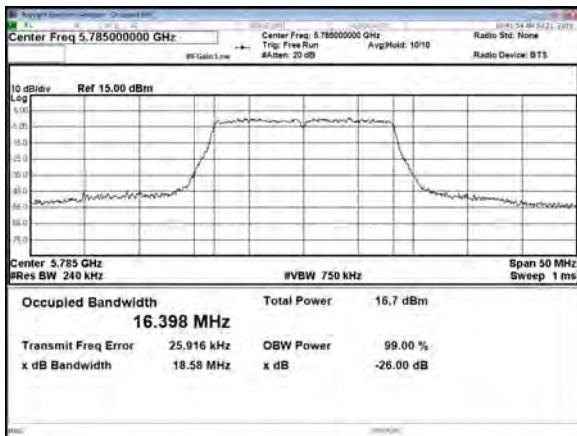

CH165

CH165

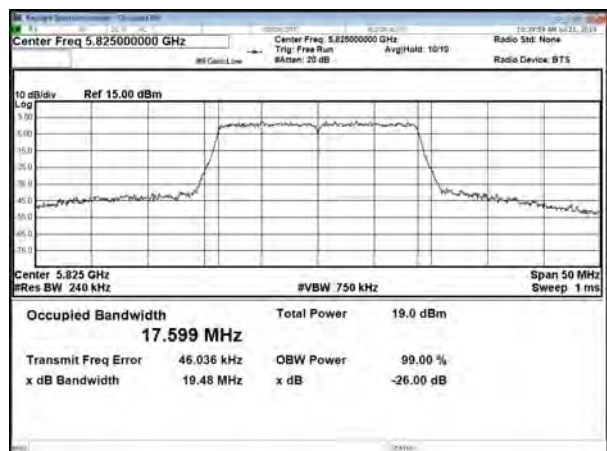
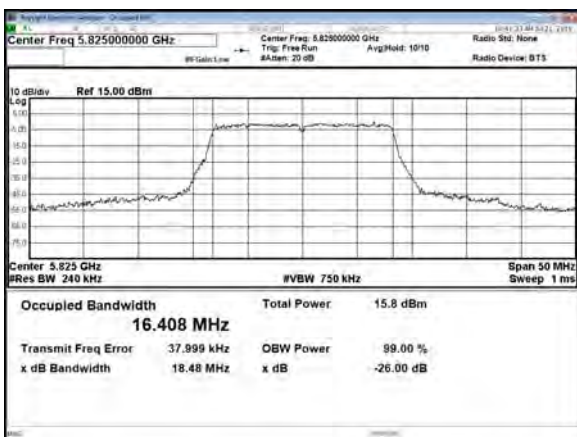



Modulation Standard: 802.11ac,VHT40
CH151

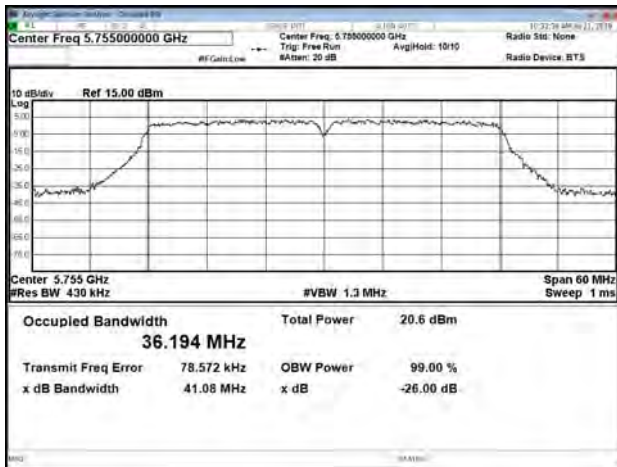

Chain 2
Modulation Standard: 802.11a
CH149

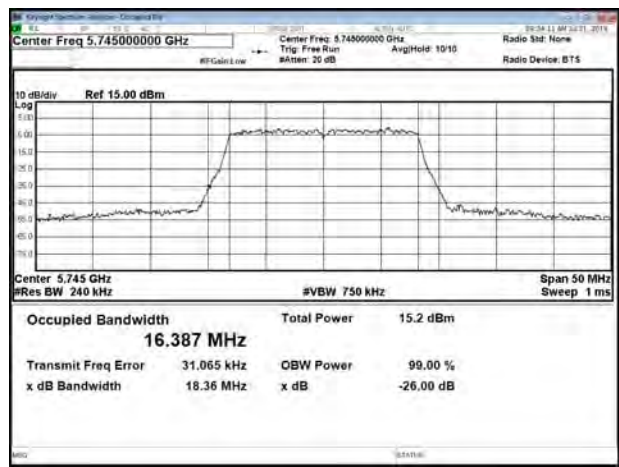

CH159

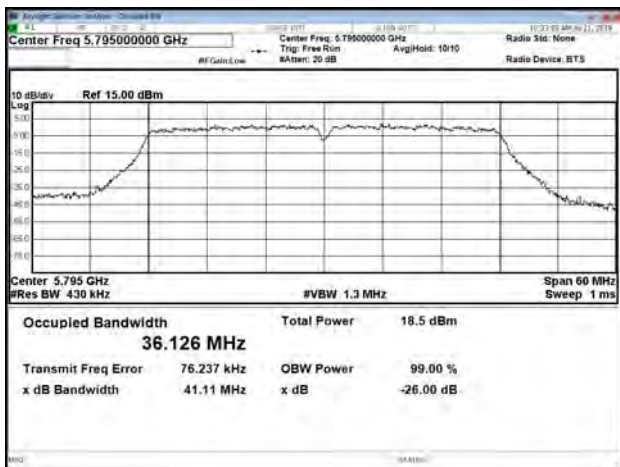

CH157

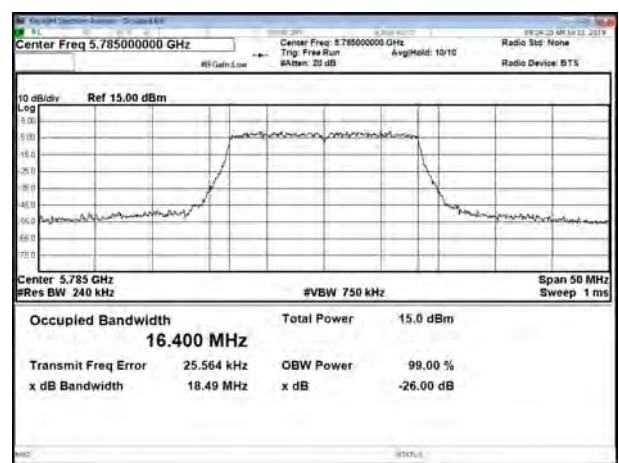

Modulation Standard: 802.11ac,VHT80
CH155

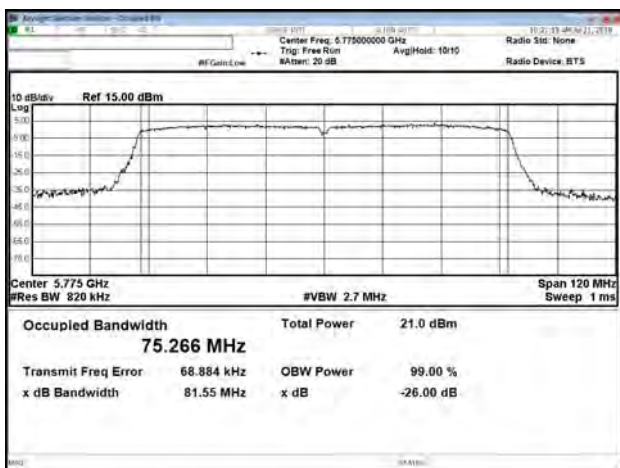

CH165

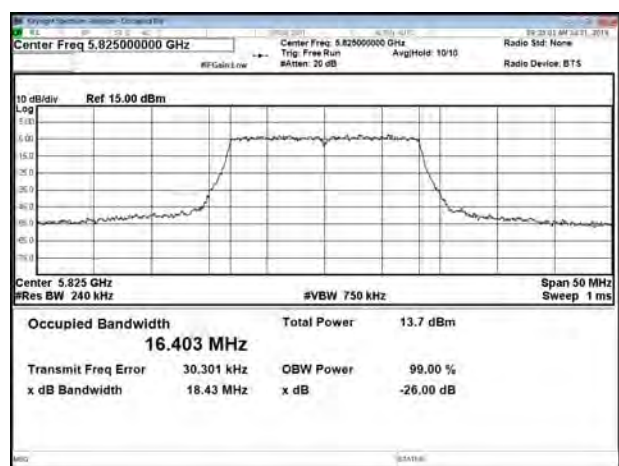



Modulation Standard: 802.11ac,VHT20
CH149

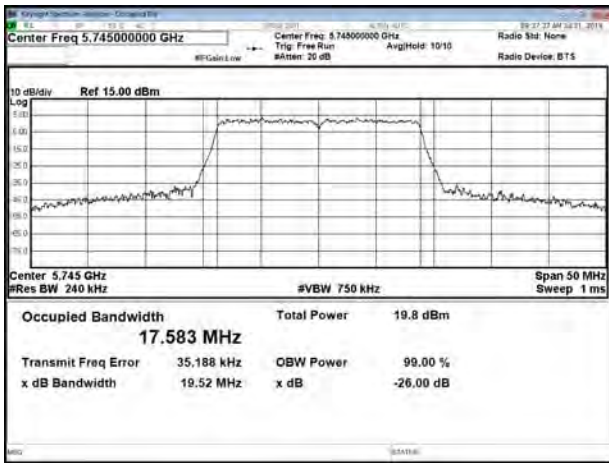

Modulation Standard: 802.11ac,VHT40
CH151

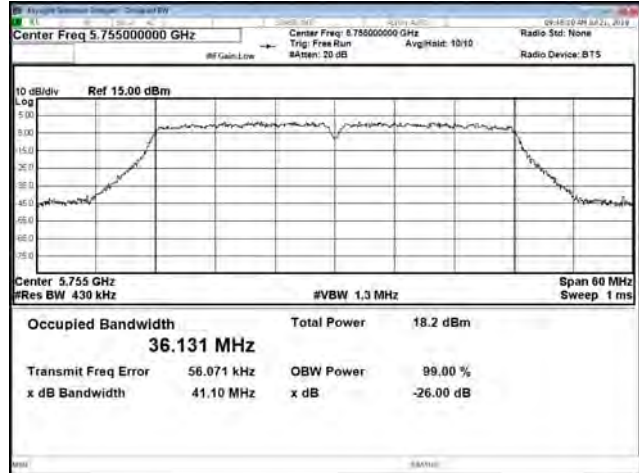

CH157



CH159

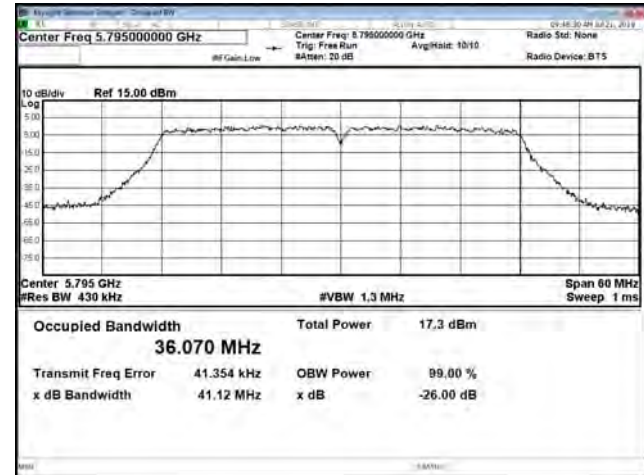

Modulation Standard: 802.11ac,VHT80
CH155

CH165

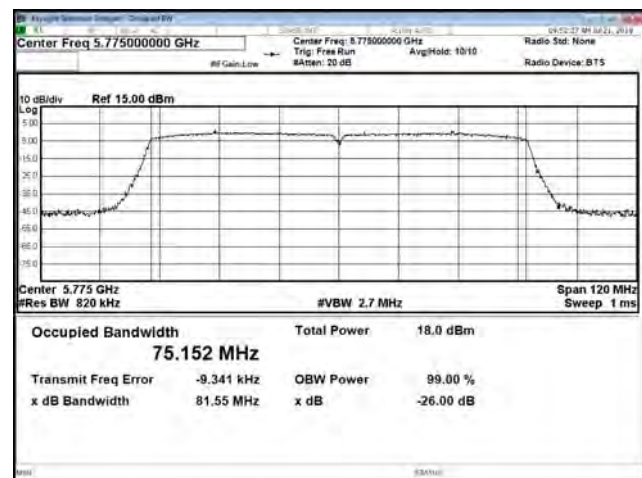



9. 26dB Bandwidth & 99% Bandwidth

9.1. Test Limit

None; for reporting purposes only.

9.2. Test Procedure

Reference to 789033 D02 General UNII Test Procedures New Rules v01: The transmitter output is connected to a spectrum analyzer with the RBW = approximately 1% of the emission bandwidth, the VBW $\geq 3 \times$ RBW, peak detector and max hold.

9.3. Test Setup Layout

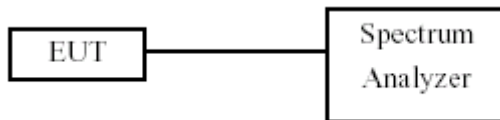

9.4. Test Result and Data

Temperature: 21°C

Humidity: 56%

Test Date: Jul. 21, 2019

In the 5.2G Band

Modulation Type	Channel	Frequency (MHz)	26dB Bandwidth (MHz)		99% Occupied Bandwidth (MHz)	
			Chain 1	Chain 2	Chain 1	Chain 2
802.11a	36	5180	18.43	18.55	16.401	16.401
	44	5220	18.47	18.43	16.394	16.392
	48	5240	18.47	18.52	16.396	16.393
802.11ac VHT20	36	5180	19.54	19.6	17.586	17.596
	44	5220	19.42	19.6	17.589	17.588
	48	5240	19.48	19.51	17.6	17.591
802.11ac VHT40	38	5190	40.83	40.68	36.086	36.086
	46	5230	41.13	40.93	36.06	36.086
802.11ac VHT80	42	5210	81.04	81.16	74.967	75.068

In the 5.3G Band

Modulation Type	Channel	Frequency (MHz)	26dB Bandwidth (MHz)		99% Occupied Bandwidth (MHz)	
			Chain 1	Chain 2	Chain 1	Chain 2
802.11a	52	5260	18.49	18.59	16.415	16.392
	60	5300	18.53	18.48	16.394	16.39
	64	5320	18.6	18.6	16.389	16.394
802.11ac VHT20	52	5260	19.6	19.49	17.586	17.585
	60	5300	19.6	19.51	17.598	17.59
	64	5320	19.55	19.49	17.596	17.582
802.11ac VHT40	54	5270	41.11	41.28	36.066	36.073
	62	5310	41.2	41.12	36.067	36.099
802.11ac VHT80	58	5290	81.11	81.12	75.069	75.089



In the 5.5G Band

Modulation Type	Channel	Frequency (MHz)	26dB Bandwidth (MHz)		99% Occupied Bandwidth (MHz)	
			Chain 1	Chain 2	Chain 1	Chain 2
802.11a	100	5500	18.49	18.53	16.405	16.398
	116	5580	18.53	18.42	16.414	16.408
	140	5700	18.61	18.5	16.423	16.399
802.11ac VHT20	100	5500	19.51	19.48	17.596	17.588
	116	5580	19.47	19.56	17.606	17.595
	140	5700	19.49	19.64	17.592	17.585
802.11ac VHT40	102	5510	41.06	40.99	36.079	36.111
	110	5550	41.55	41.1	36.15	36.133
	134	5670	41.04	41.03	36.116	36.105
802.11ac VHT80	106	5530	81.69	81.63	75.39	75.327



26dB Bandwidth & 99% Bandwidth
5.2G Band:
Chain 1
Modulation Standard: 802.11a
CH36

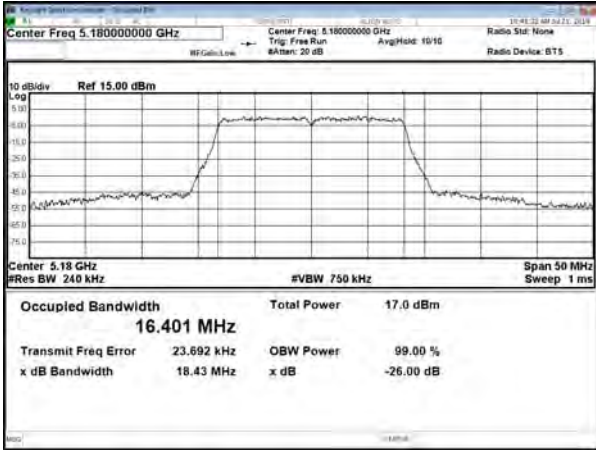

Modulation Standard: 802.11ac,VHT20
CH36

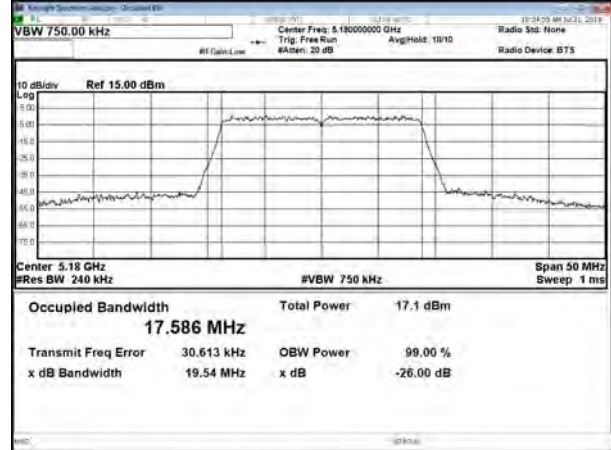

CH44

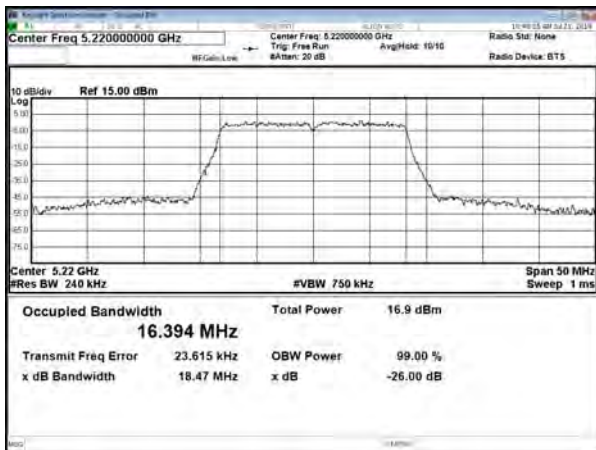

CH44

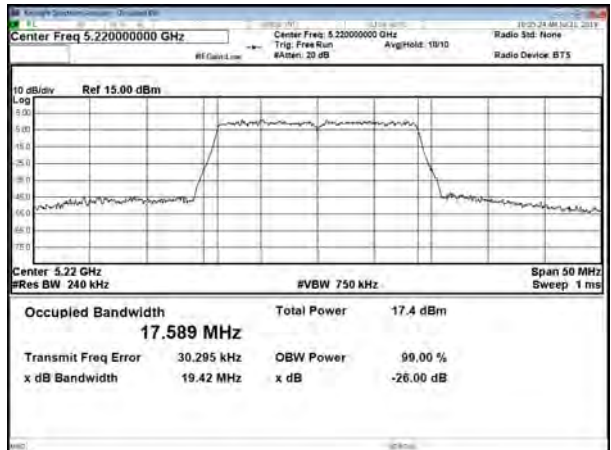

CH48

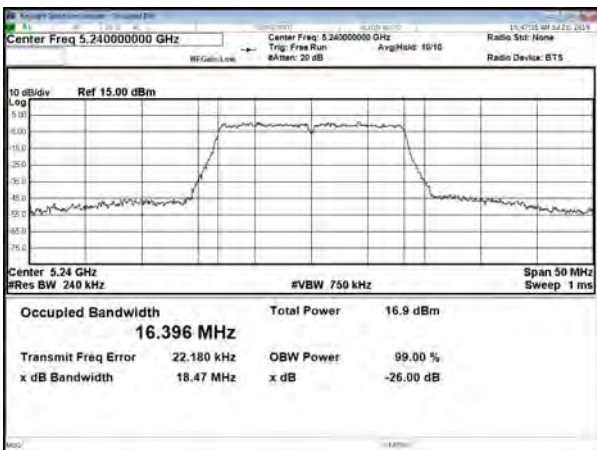

CH48

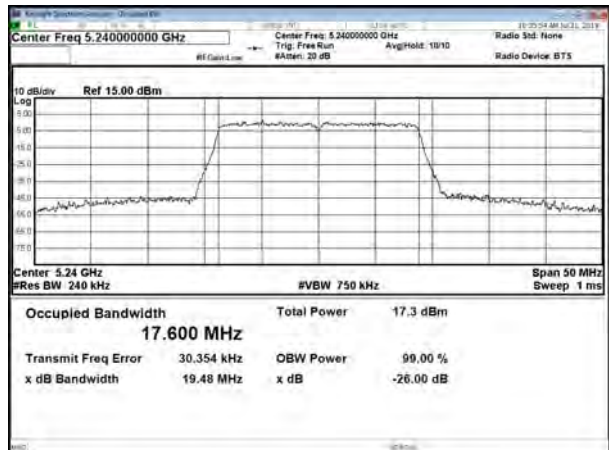



Modulation Standard: 802.11ac,VHT40
CH38

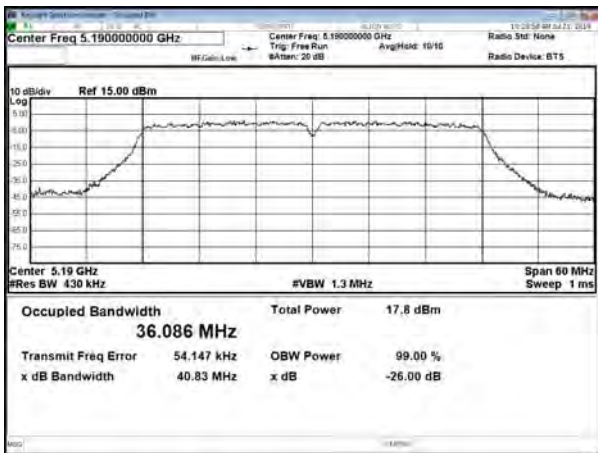

Chain 2
Modulation Standard: 802.11a
CH36

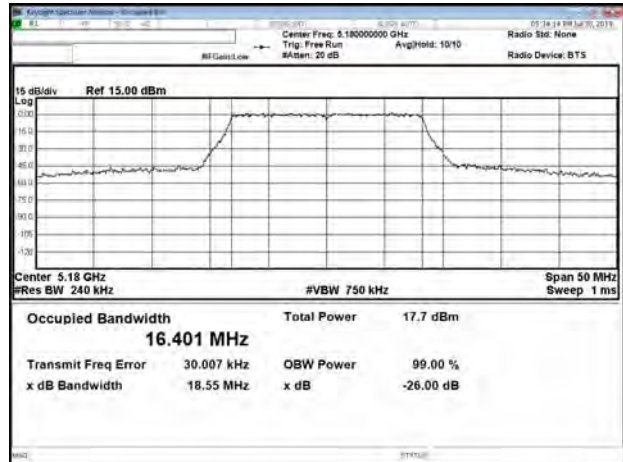

CH46



CH44

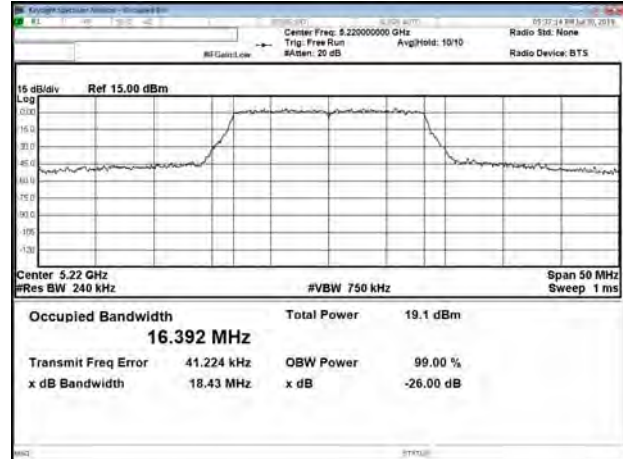

Modulation Standard: 802.11ac,VHT80 (58.5Mbps)

CH42

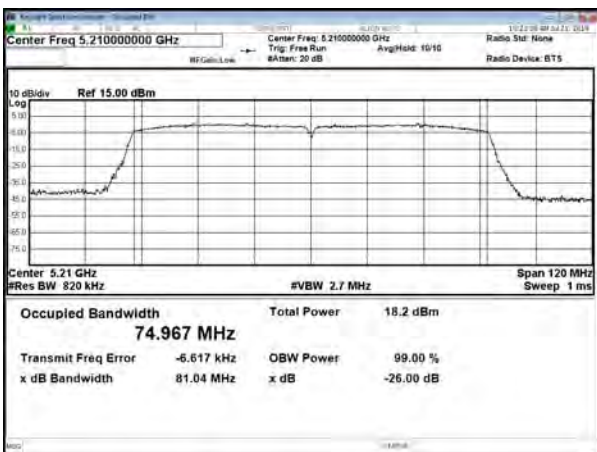

CH48

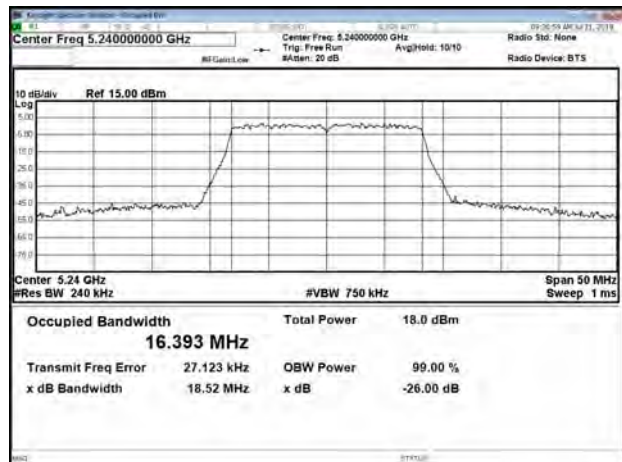



Modulation Standard: 802.11ac,VHT20
CH36

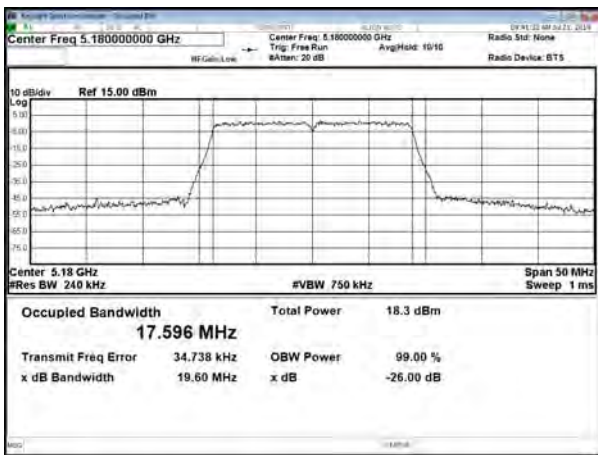

Modulation Standard: 802.11ac,VHT40
CH38

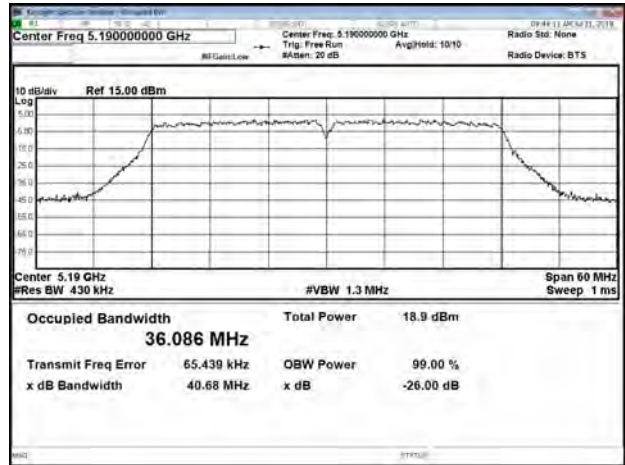

CH44

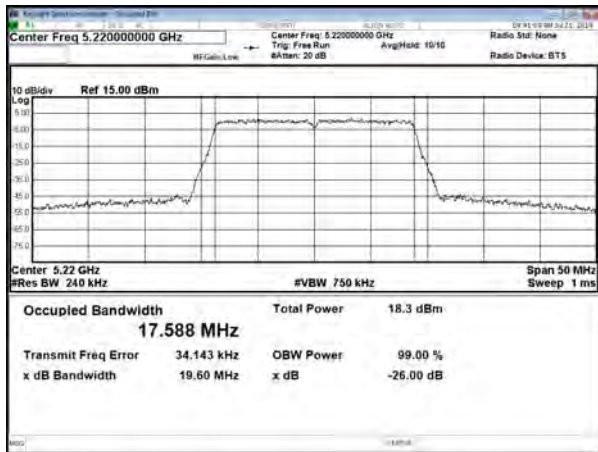

CH46

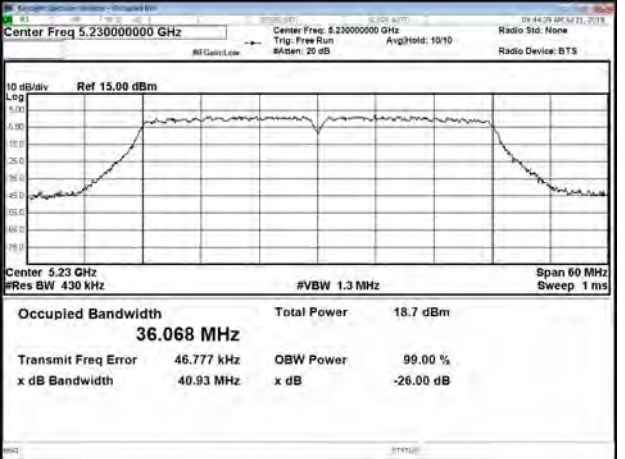

Modulation Standard: 802.11ac,VHT80

CH48

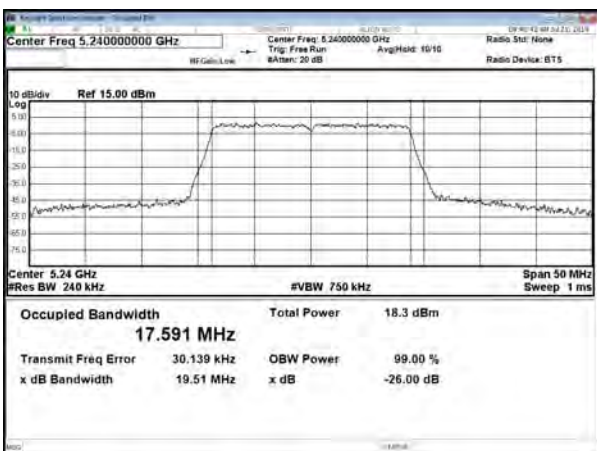

CH42

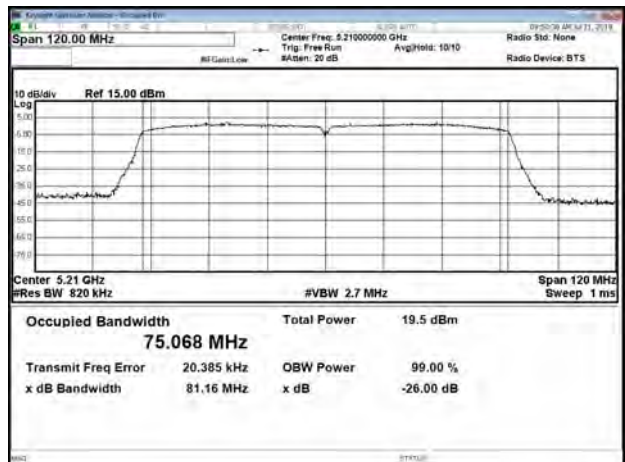



5.3G Band:
Chain 1
Modulation Standard: 802.11a
CH52

Modulation Standard: 802.11ac,VHT20
CH52

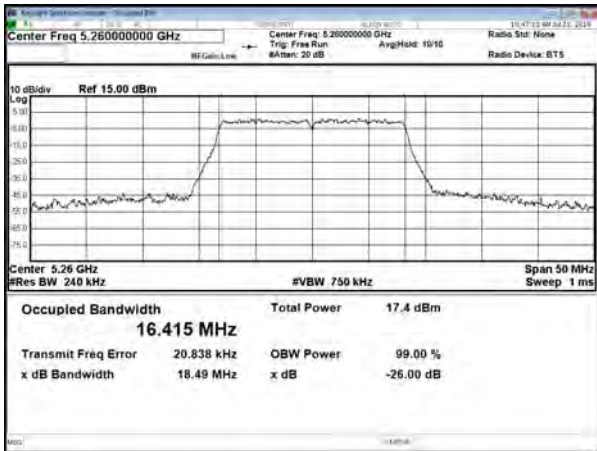

CH60

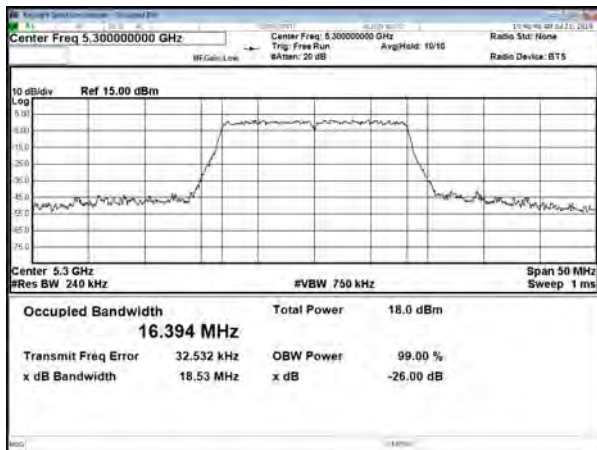

CH60

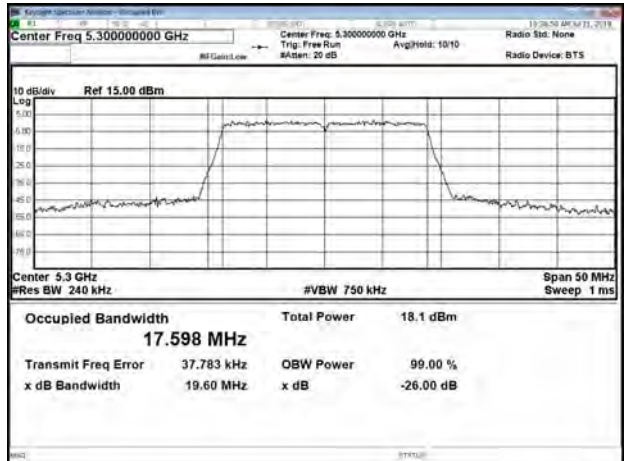

CH64

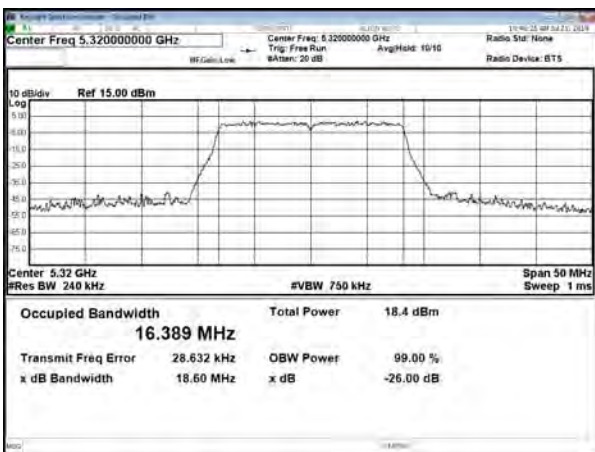

CH64

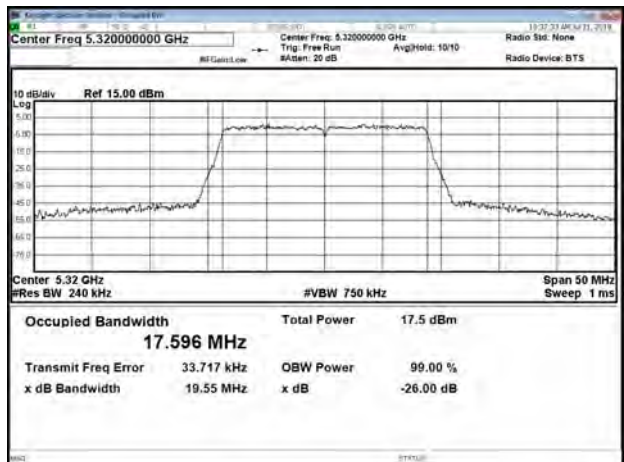



Modulation Standard: 802.11ac,VHT40
CH54

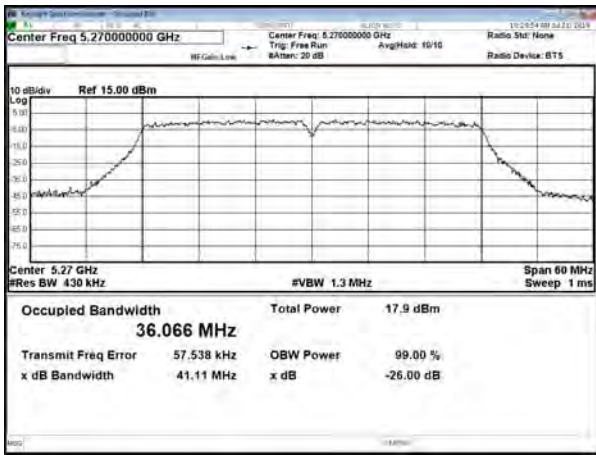

Chain 2
Modulation Standard: 802.11a
CH52

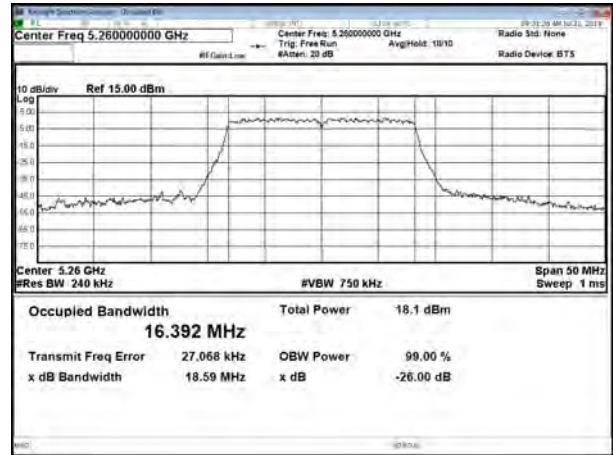

CH62

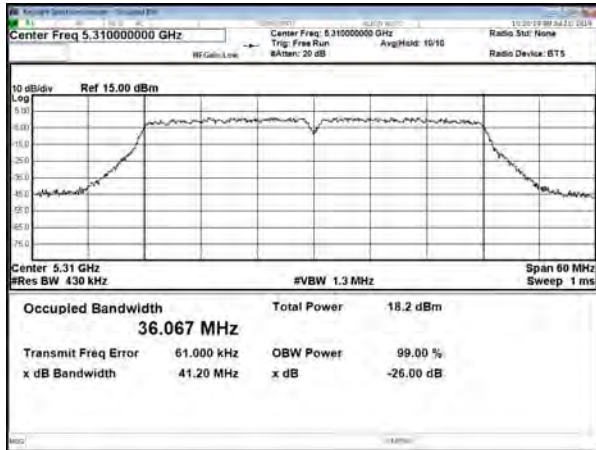

CH60

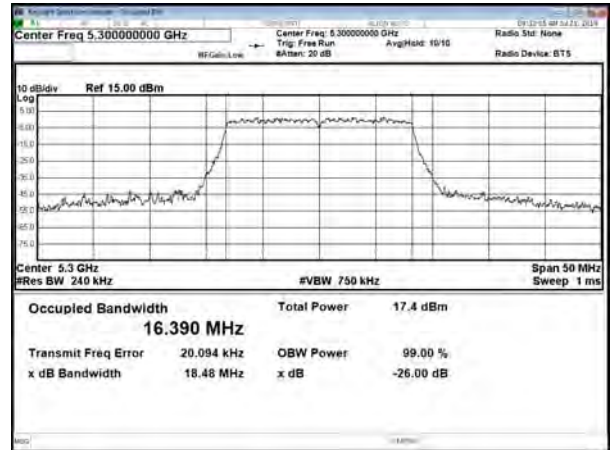

Modulation Standard: 802.11ac,VHT80
CH58



CH64

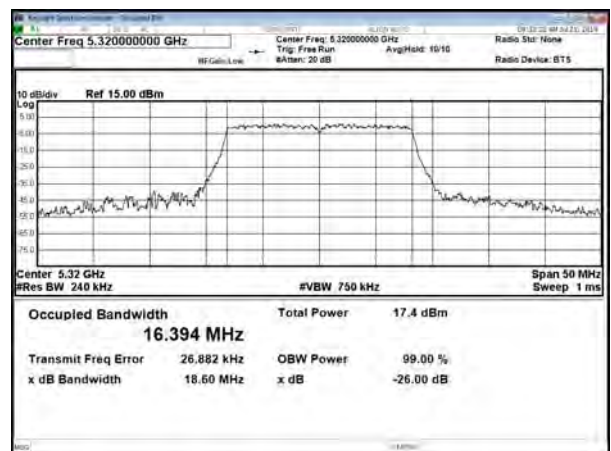



Modulation Standard: 802.11ac,VHT20
CH52

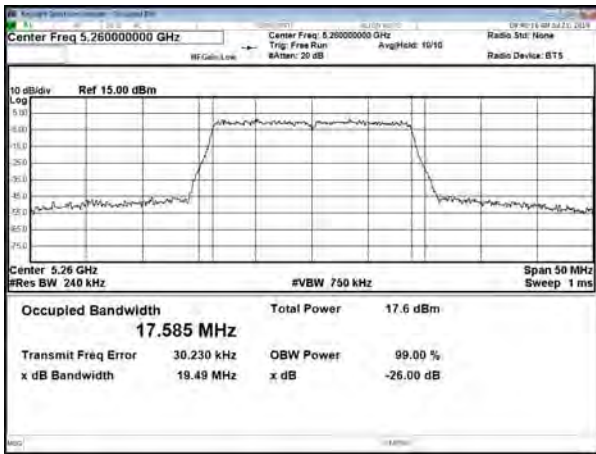

Modulation Standard: 802.11ac,VHT40
CH54

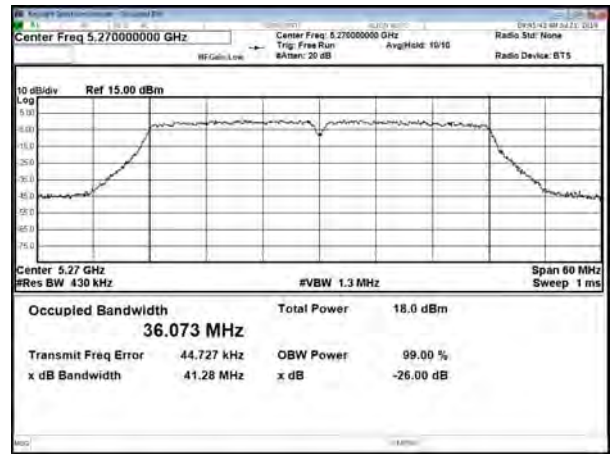

CH60

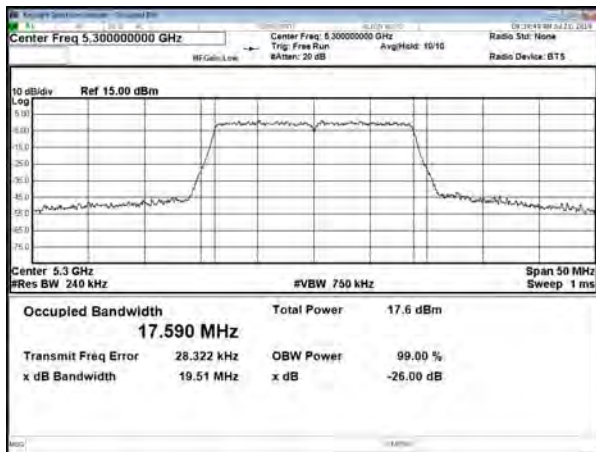

CH62

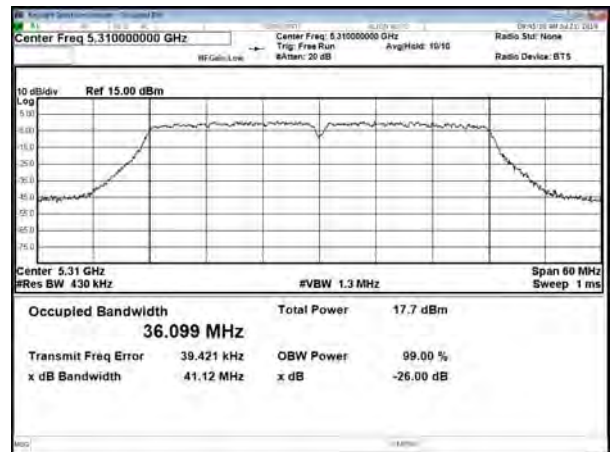

Modulation Standard: 802.11ac,VHT80

CH64

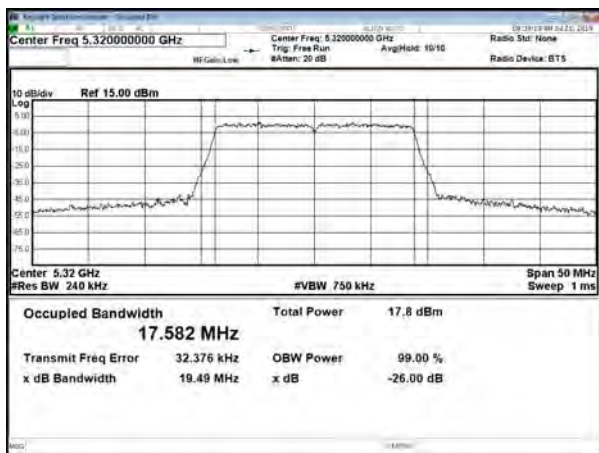

CH58

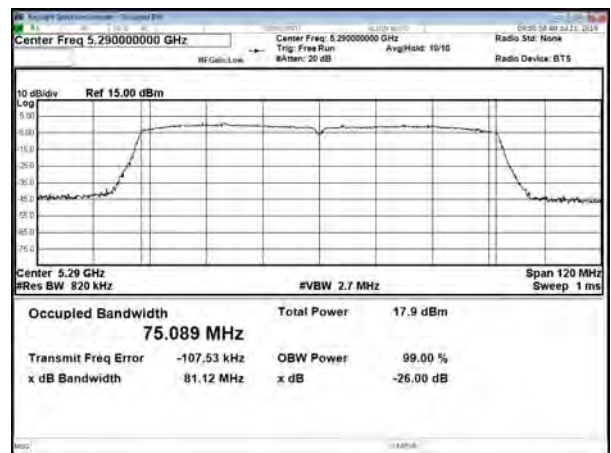



5.5G Band:
Chain 1
Modulation Standard: 802.11a
CH100

Modulation Standard: 802.11ac,VHT20
CH100

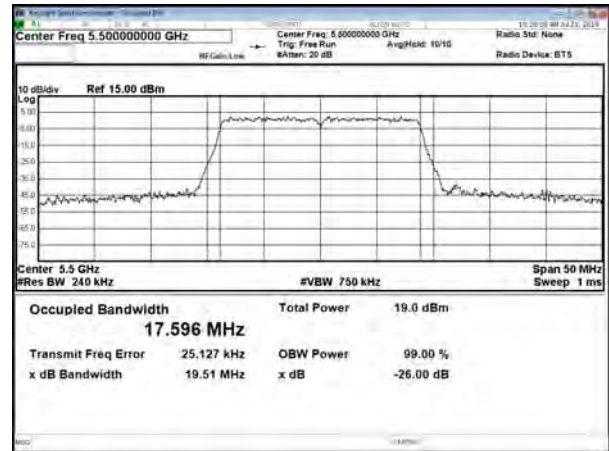
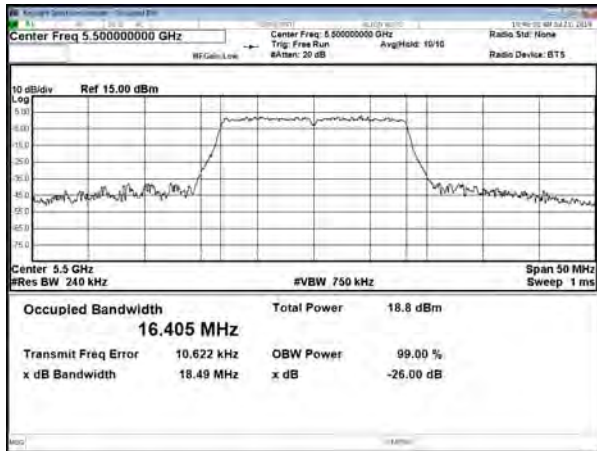

CH116

CH116

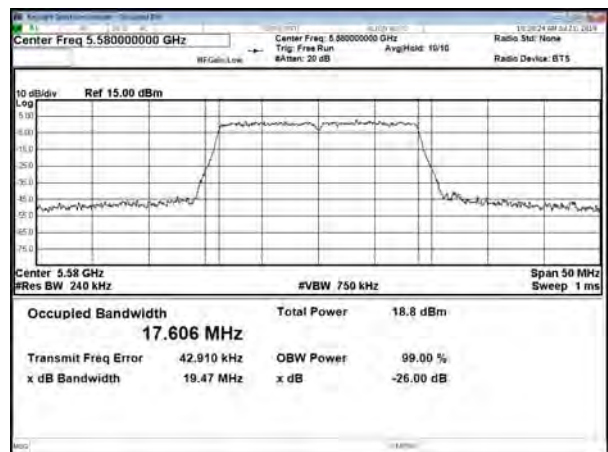
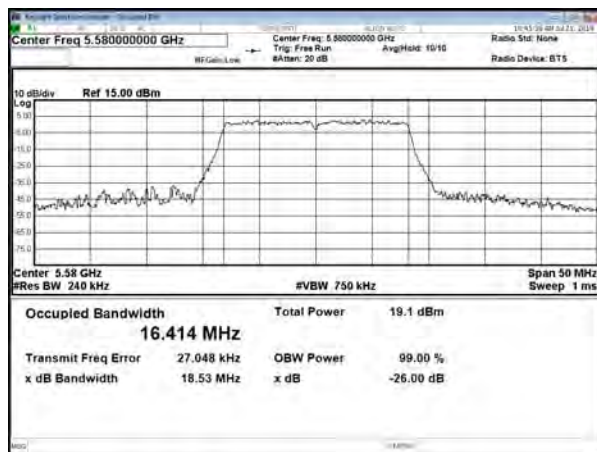

CH140

CH140

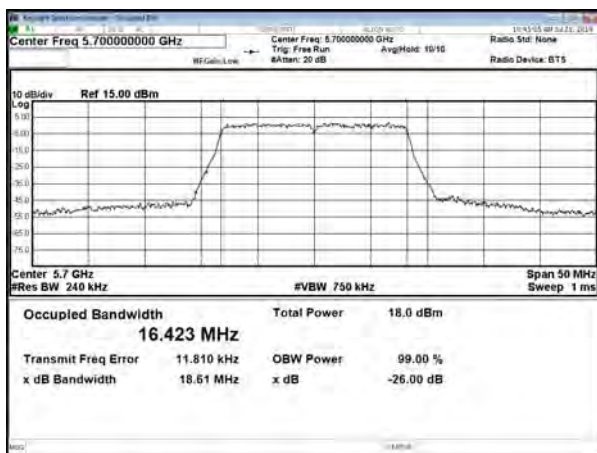



Modulation Standard: 802.11ac,VHT40
CH102

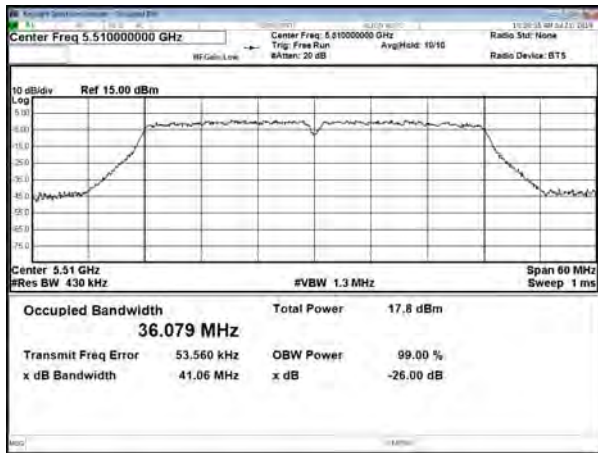

Modulation Standard: 802.11ac,VHT80
CH106

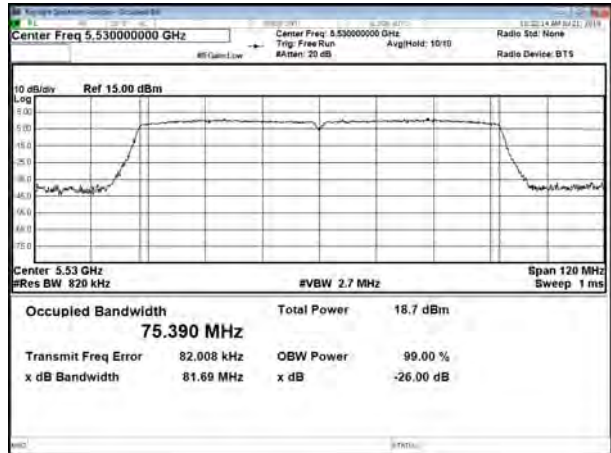

CH110

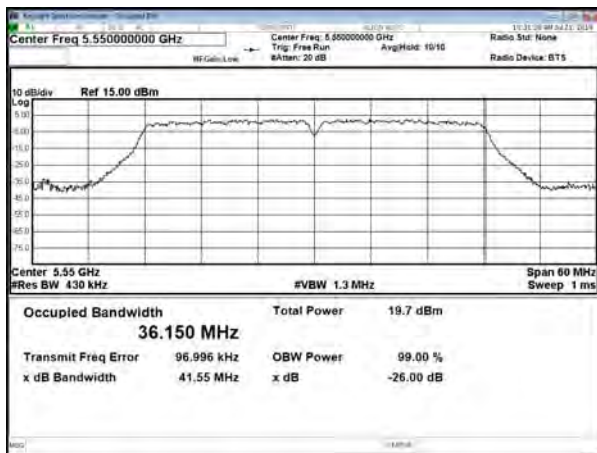

CH122



CH134





Chain 2
Modulation Standard: 802.11a
CH100

Modulation Standard: 802.11ac,VHT20
CH100

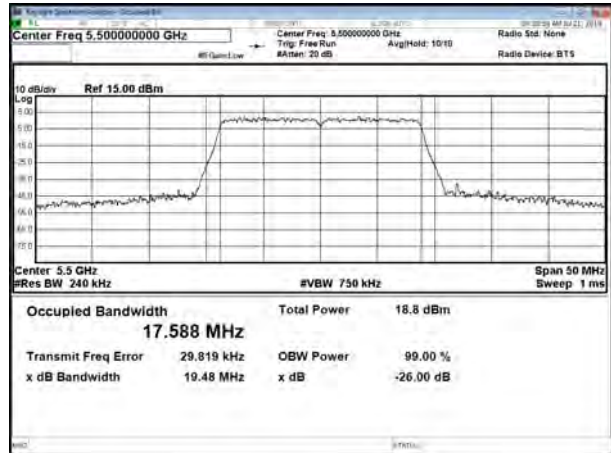
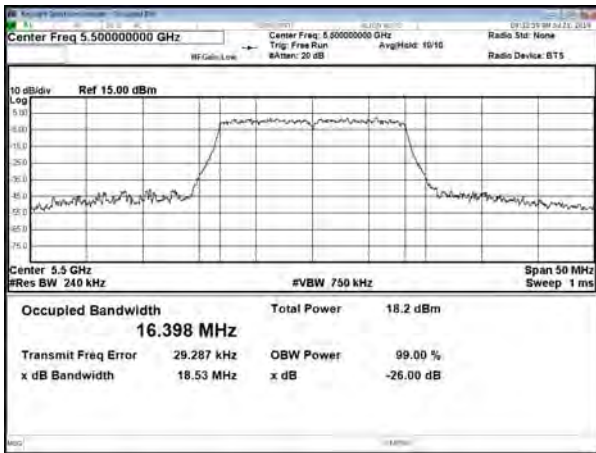

CH116

CH116

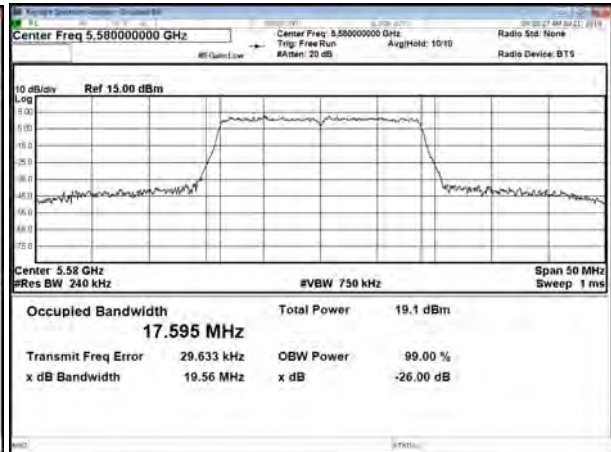
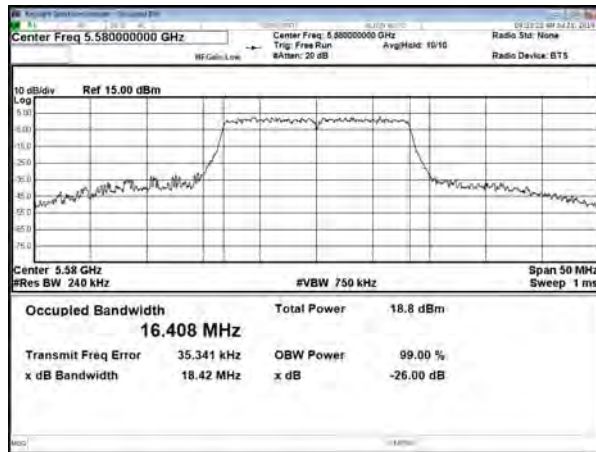

CH140

CH140

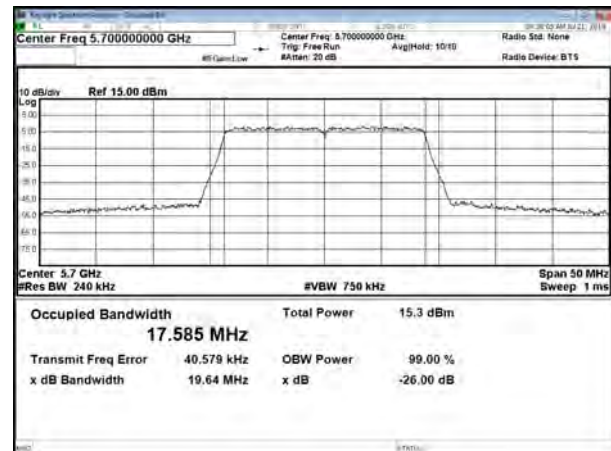



Modulation Standard: 802.11ac,VHT40
CH102

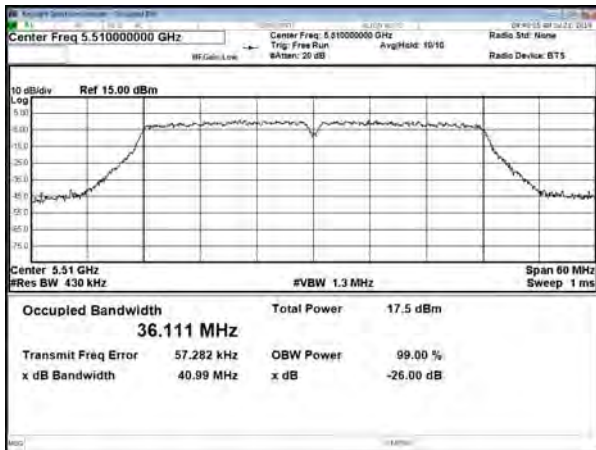

Modulation Standard: 802.11ac,VHT80
CH106

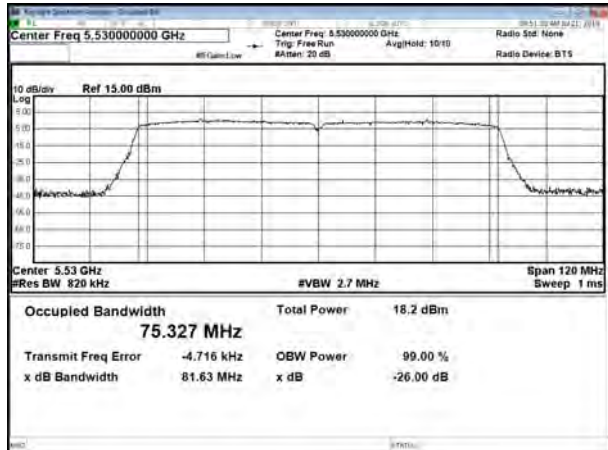

CH110



CH122

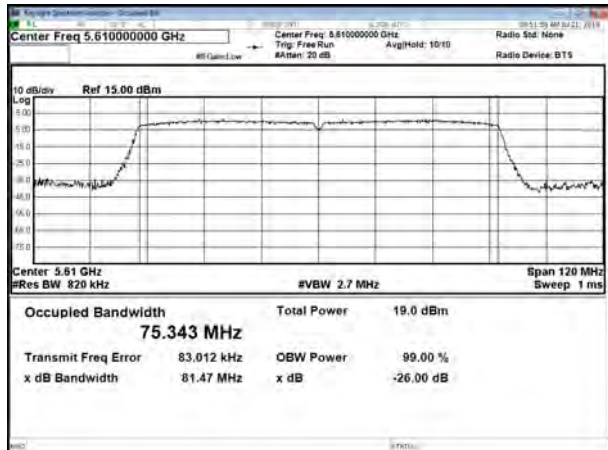

CH134

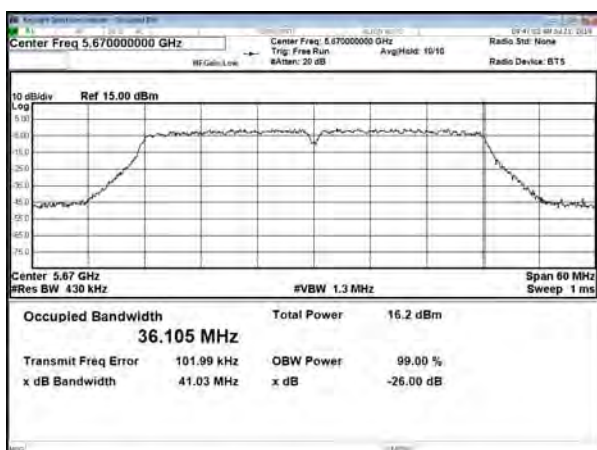



10. Average Power

10.1. Test Limit

Output Power:

Frequency Band	Limit	
<input checked="" type="checkbox"/> 5.15~5.25GHz		
	Operating Mode	
<input type="checkbox"/>	Outdoor access point	The maximum conducted output power over the frequency band of operation shall not exceed 1 W (30dBm) provided the maximum antenna gain does not exceed 6 dBi. If transmitting antennas of directional gain greater than 6 dBi are used, both the maximum conducted output power and the maximum power spectral density shall be reduced by the amount in dB that the directional gain of the antenna exceeds 6 dBi. The maximum e.i.r.p. at any elevation angle above 30degrees as measured from the horizon must not exceed 125 mW (21 dBm).
<input type="checkbox"/>	Indoor access point	The maximum conducted output power over the frequency band of operation shall not exceed 1 W (30dBm) provided the maximum antenna gain does not exceed 6 dBi. If transmitting antennas of directional gain greater than 6 dBi are used, both the maximum conducted output power and the maximum power spectral density shall be reduced by the amount in dB that the directional gain of the antenna exceeds 6 dBi.
<input type="checkbox"/>	Fixed point-to-point access points	The maximum conducted output power over the frequency band of operation shall not exceed 1 W (30dBm). Fixed point-to-point U-NII devices may employ antennas with directional gain up to 23 dBi without any corresponding reduction in the maximum conducted output power or maximum power spectral density. For fixed point-to-point transmitters that employ a directional antenna gain greater than 23 dBi, a 1 dB reduction in maximum conducted output power and maximum power spectral density is required for each 1 dB of antenna gain in excess of 23 dBi.
<input checked="" type="checkbox"/>	client devices	The maximum conducted output power over the frequency band of operation shall not exceed 250 mW (24dBm) provided the maximum antenna gain does not exceed 6 dBi. If transmitting antennas of directional gain greater than 6 dBi are used, both the maximum conducted output power and the maximum power spectral density shall be reduced by the amount in dB that the directional gain of the antenna exceeds 6 dBi.



Frequency Band		Limit
<input checked="" type="checkbox"/>	5.25-5.35 GHz	The maximum conducted output power over the frequency bands of operation shall not exceed the lesser of 250 mW (24dBm) or 11 dBm 10 log B, where B is the 26 dB emission bandwidth in megahertz. If transmitting antennas of directional gain greater than 6 dBi are used, both the maximum conducted output power and the maximum power spectral density shall be reduced by the amount in dB that the directional gain of the antenna exceeds 6 dBi.
<input checked="" type="checkbox"/>	5.470-5.725 GHz	
<input checked="" type="checkbox"/>	5.725~5.85 GHz	

10.2. Test Procedure

The transmitter output is connected to a power meter.

The cable assembly insertion loss of 11 dB (including 10 dB pad and 1 dB cable) was entered as an offset in the power meter to allow for direct reading of power.

10.3. Test Setup Layout

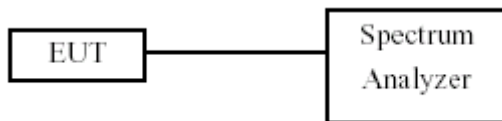

**10.4. Test Result and Data**

Temperature: 21°C

Humidity: 56%

Test Date: Jul. 20, 2019

In the 5.2G Band

Modulation Type	Channel	Frequency (MHz)	Avg Power Output (dBm)		Total Power (dBm)	Total Power (mW)	Power Limit (dBm)
			Chain 1	Chain 2			
802.11a	36	5180	11.09	12.64	14.94	31.218	24.00
	44	5220	11.70	11.90	14.81	30.279	24.00
	48	5240	11.28	11.77	14.54	28.459	24.00
802.11an HT20	36	5180	10.64	12.33	14.58	28.688	24.00
	44	5220	10.51	12.16	14.42	27.690	24.00
	48	5240	10.77	12.15	14.52	28.346	24.00
802.11an HT40	38	5190	11.41	11.99	14.72	29.648	24.00
	46	5230	11.20	12.08	14.67	29.326	24.00
802.11ac VHT20	36	5180	10.83	12.47	14.74	29.766	24.00
	44	5220	10.77	12.26	14.59	28.767	24.00
	48	5240	10.95	12.26	14.66	29.272	24.00
802.11ac VHT40	38	5190	11.44	12.10	14.79	30.150	24.00
	46	5230	11.22	12.14	14.71	29.612	24.00
802.11ac VHT80	42	5210	10.97	12.00	14.53	28.352	24.00

In the 5.3G Band

Modulation Type	Channel	Frequency (MHz)	Avg Power Output (dBm)		Total Power (dBm)	Total Power (mW)	Power Limit (dBm)
			Chain 1	Chain 2			
802.11a	52	5260	11.39	11.61	14.51	28.260	24.00
	60	5300	11.91	11.08	14.53	28.347	24.00
	64	5320	12.1	11.21	14.69	29.431	24.00
802.11an HT20	52	5260	11.17	11.70	14.45	27.883	24.00
	60	5300	11.54	11.44	14.50	28.188	24.00
	64	5320	11.98	11.39	14.71	29.548	24.00
802.11an HT40	54	5270	11.53	11.03	14.30	26.900	24.00
	62	5310	12.63	11.28	15.02	31.751	24.00
802.11ac VHT20	52	5260	11.29	11.86	14.59	28.805	24.00
	60	5300	11.76	11.52	14.65	29.187	24.00
	64	5320	12.03	11.45	14.76	29.922	24.00
802.11ac VHT40	54	5270	11.72	11.26	14.51	28.225	24.00
	62	5310	12.79	11.39	15.16	32.783	24.00
802.11ac VHT80	58	5290	12.06	10.62	14.41	27.604	24.00

**In the 5.5G Band**

Modulation Type	Channel	Frequency (MHz)	Avg Power Output (dBm)		Total Power (dBm)	Total Power (mW)	Power Limit (dBm)
			Chain 1	Chain 2			
802.11a	100	5500	12.74	11.99	15.39	34.606	24.00
	116	5580	13.74	12.73	16.27	42.409	24.00
	140	5700	11.99	8.74	13.67	23.294	24.00
802.11an HT20	100	5500	13.26	12.62	15.96	39.465	24.00
	116	5580	12.54	13.17	15.88	38.696	24.00
	140	5700	11.42	8.71	13.28	21.298	24.00
802.11an HT40	102	5510	11.38	11.20	14.30	26.923	24.00
	110	5550	13.01	13.24	16.14	41.085	24.00
	134	5670	11.85	10.05	14.05	25.427	24.00
802.11ac VHT20	100	5500	13.38	12.32	15.89	38.838	24.00
	116	5580	12.60	13.40	16.03	40.075	24.00
	140	5700	11.52	8.94	13.43	22.025	24.00
802.11ac VHT40	102	5510	11.60	11.39	14.51	28.226	24.00
	110	5550	13.19	13.93	16.59	45.562	24.00
	134	5670	11.90	10.11	14.11	25.745	24.00
802.11ac VHT80	106	5530	11.70	10.57	14.18	26.194	24.00
	122	5610	12.17	11.74	14.97	31.410	24.00

In the 5.8G Band

Modulation Type	Channel	Frequency (MHz)	Avg Power Output (dBm)		Total Power (dBm)	Total Power (mW)	Power Limit (dBm)
			Chain 1	Chain 2			
802.11a	149	5745	11.59	9.30	13.60	22.933	30.00
	157	5785	10.84	9.13	13.08	20.319	30.00
	165	5825	9.09	7.69	11.46	13.985	30.00
802.11an HT20	149	5745	15.33	12.66	17.21	52.569	30.00
	157	5785	14.16	12.47	16.41	43.722	30.00
	165	5825	13.75	11.31	15.71	37.234	30.00
802.11an HT40	151	5755	13.99	11.89	16.08	40.514	30.00
	159	5795	12.44	10.87	14.74	29.757	30.00
802.11ac VHT20	149	5745	15.47	13.22	17.50	56.226	30.00
	157	5785	14.40	12.53	16.58	45.448	30.00
	165	5825	13.82	11.45	15.81	38.063	30.00
802.11ac VHT40	151	5755	14.09	12.03	16.19	41.604	30.00
	159	5795	12.64	10.90	14.87	30.668	30.00
802.11ac VHT80	155	5775	12.69	11.38	15.09	32.318	30.00



11. PPSD

11.1. Test Limit

PSD:

Frequency Band		Limit
<input checked="" type="checkbox"/>	5.15~5.25GHz	
	Operating Mode	
<input type="checkbox"/>	Outdoor access point	17 dBm/MHz
<input type="checkbox"/>	Indoor access point	17 dBm/MHz
<input type="checkbox"/>	Fixed point-to-point access points	17 dBm/MHz
<input checked="" type="checkbox"/>	Mobile and portable client devices	11 dBm/MHz
<input checked="" type="checkbox"/>	5.725~5.85 GHz	11 dBm/MHz
<input checked="" type="checkbox"/>	5.470-5.725 GHz	11 dBm/MHz
<input checked="" type="checkbox"/>	5.725~5.85 GHz	30 dBm/500kHz

11.2. Test Procedure

Reference to KDB789033 D02 General UNII Test Procedures New Rules v02r01

11.3. Test Setup Layout

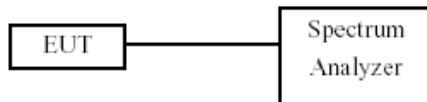

**11.4. Test Result and Data**

Temperature: 21°C

Humidity: 56%

Test Date: Jul. 20, 2019

In the 5.2G Band

Modulation Type	CH	Freq. (MHz)	Meas PPSD (dBm/MHz)		Sum chain (dBm)	Duty Cycle CF(dB)	Total Corr'd PPSD (dBm/MHz)	PPSD Limit (dBm/MHz)
			Chain 1	Chain 2				
802.11a	36	5180	0.406	0.774	3.60	0.00	3.60	10.46
	44	5220	-0.044	0.515	3.25	0.00	3.25	10.46
	48	5240	0.062	0.992	3.56	0.00	3.56	10.46
802.11ac VHT20	36	5180	-0.564	0.927	3.26	0.00	3.26	10.46
	44	5220	-0.458	0.386	2.99	0.00	2.99	10.46
	48	5240	-0.118	0.115	3.01	0.00	3.01	10.46
802.11ac VHT40	38	5190	-2.467	-1.718	0.93	0.00	0.93	10.46
	46	5230	-3.024	-2.181	0.43	0.00	0.43	10.46
802.11ac VHT80	42	5210	-6.178	-5.222	-2.66	0.00	-2.66	10.46

Note: PPSD Limit:11-(6.54-6)=10.46dBm/MHz

In the 5.3G Band

Modulation Type	CH	Freq. (MHz)	Meas PPSD (dBm/MHz)		Sum chain (dBm)	Duty Cycle CF(dB)	Total Corr'd PPSD (dBm/MHz)	PPSD Limit (dBm/MHz)
			Chain 1	Chain 2				
802.11a	52	5260	-0.026	0.668	3.35	0.00	3.35	10.46
	60	5300	0.536	0	3.29	0.00	3.29	10.46
	64	5320	0.66	0.131	3.41	0.00	3.41	10.46
802.11ac VHT20	52	5260	0.306	-0.112	3.11	0.00	3.11	10.46
	60	5300	0.511	-0.744	2.94	0.00	2.94	10.46
	64	5320	0.401	0.008	3.22	0.00	3.22	10.46
802.11ac VHT40	54	5270	-2.66	-2.897	0.23	0.00	0.23	10.46
	62	5310	-2.101	-3.316	0.34	0.00	0.34	10.46
802.11ac VHT80	58	5290	-5.808	-6.11	-2.95	0.00	-2.95	10.46

Note: PPSD Limit:11-(6.54-6)=10.46dBm/MHz

**In the 5.5G Band**

Modulation Type	CH	Freq. (MHz)	Meas PPSD (dBm/MHz)		Sum chain (dBm)	Duty Cycle CF(dB)	Total Corr'd PPSD (dBm/MHz)	PPSD Limit (dBm/MHz)
			Chain 1	Chain 2				
802.11a	100	5500	1.3	1.412	4.37	0.00	4.37	10.75
	116	5580	1.908	2.504	5.23	0.00	5.23	10.75
	140	5700	0.653	-1.408	2.75	0.00	2.75	10.75
802.11ac VHT20	100	5500	1.214	1.219	4.23	0.00	4.23	10.75
	116	5580	1.176	2.204	4.73	0.00	4.73	10.75
	140	5700	-0.216	-1.865	2.05	0.00	2.05	10.75
802.11ac VHT40	102	5510	-2.775	-2.98	0.13	0.00	0.13	10.75
	110	5550	-1.008	-1.051	1.98	0.00	1.98	10.75
	134	5670	-2.117	-4.201	-0.02	0.00	-0.02	10.75
802.11ac VHT80	106	5530	-6.215	-6.058	-3.13	0.00	-3.13	10.75
	122	5610	-4.671	-5.41	-2.01	0.00	-2.01	10.75

Note: PPSD Limit:11-(6.25-6)=10.75dBm/MHz

In the 5.8G Band

Modulation Type	CH	Freq. (MHz)	Meas PPSD (dBm/MHz)		Sum chain (dBm)	Duty Cycle CF(dB)	10log(500K Hz/RBW) CF (dB)	Total Corr'd PPSD (dBm/500kHz)	PPSD Limit (dBm/500kHz)
			Chain 1	Chain 2					
802.11a	149	5745	0.42	-1.133	2.72	0.00	-3.01	-0.29	28.63
	157	5785	-1.015	-1.801	1.62	0.00	-3.01	-1.39	28.63
	165	5825	-2.297	-2.75	0.49	0.00	-3.01	-2.52	28.63
802.11ac VHT20	149	5745	3.837	2.257	6.13	0.00	-3.01	3.12	28.63
	157	5785	3.223	1.865	5.61	0.00	-3.01	2.60	28.63
	165	5825	1.968	0.72	4.40	0.00	-3.01	1.39	28.63
802.11ac VHT40	155	5755	-0.226	-2.314	1.86	0.00	-3.01	-1.15	28.63
	159	5795	-1.714	-3.102	0.66	0.00	-3.01	-2.35	28.63
802.11ac VHT80	155	5775	-4.019	-5.559	-1.71	0.00	-3.01	-4.72	28.63

Note: PPSD Limit:30-(7.37-6)=28.63dBm/MHz



5.2G Band:

Chain 1

Modulation Standard: 802.11a
CH36

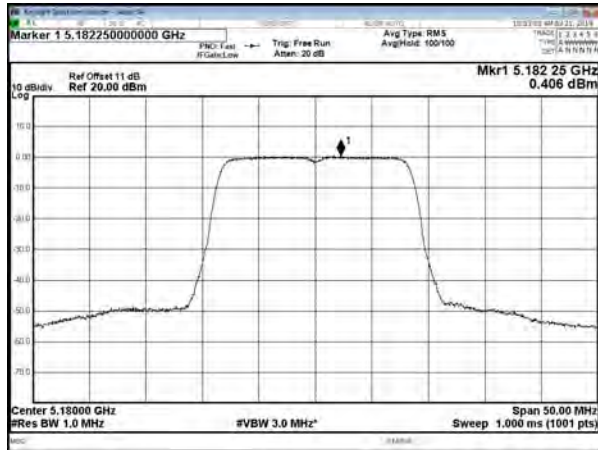

Modulation Standard: 802.11ac, VHT20
CH36

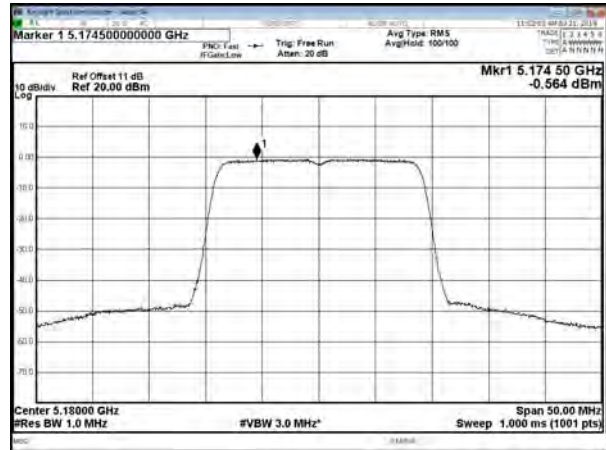

CH44

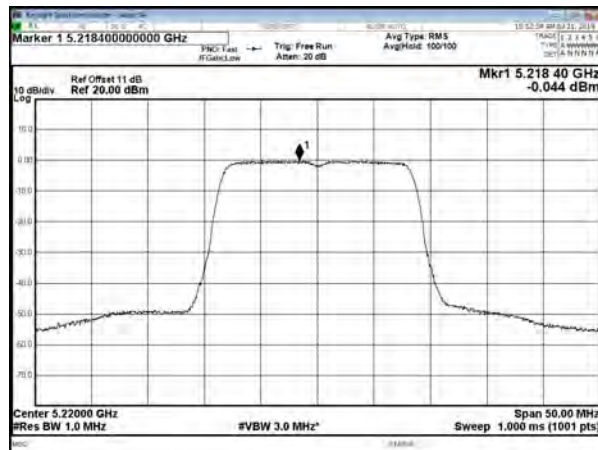

CH44

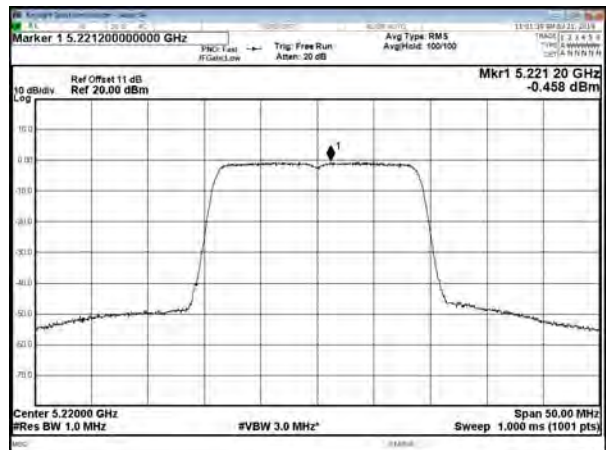

CH48

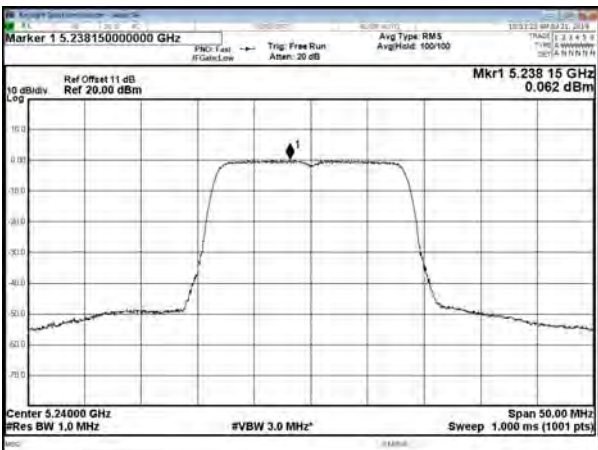

CH48

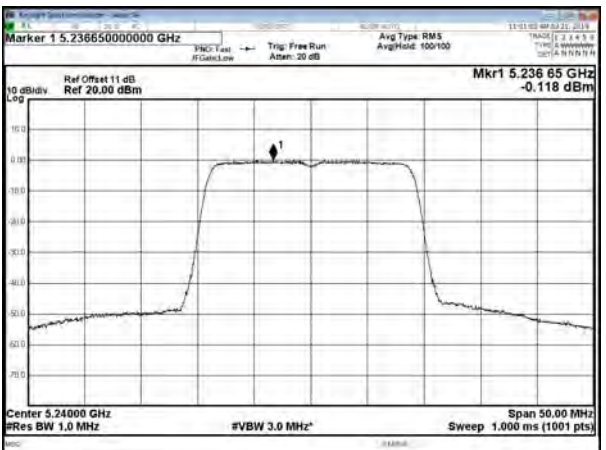



Modulation Standard: 802.11ac,VHT40
CH38

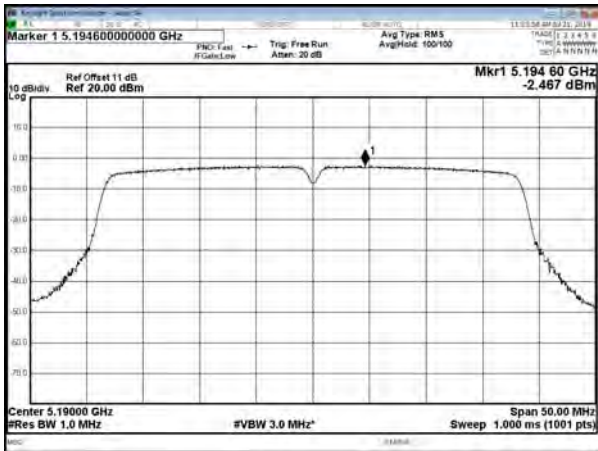

Chain 2
Modulation Standard: 802.11a
CH36

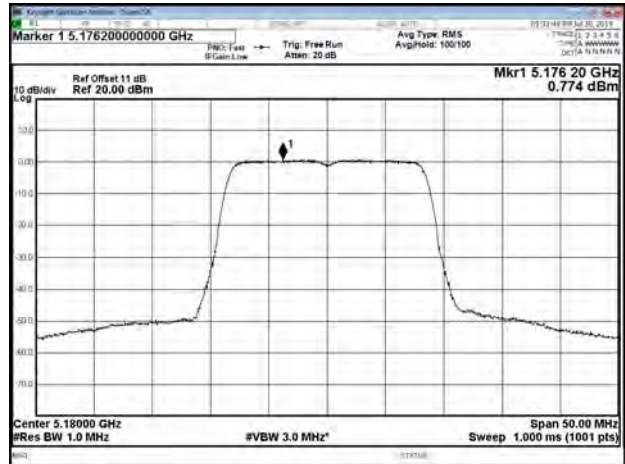

CH46

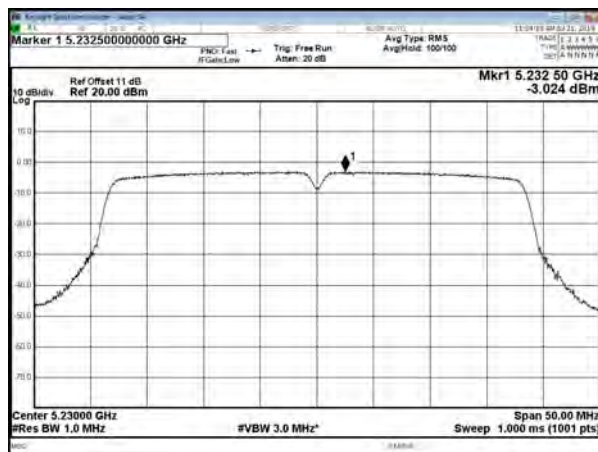

CH44

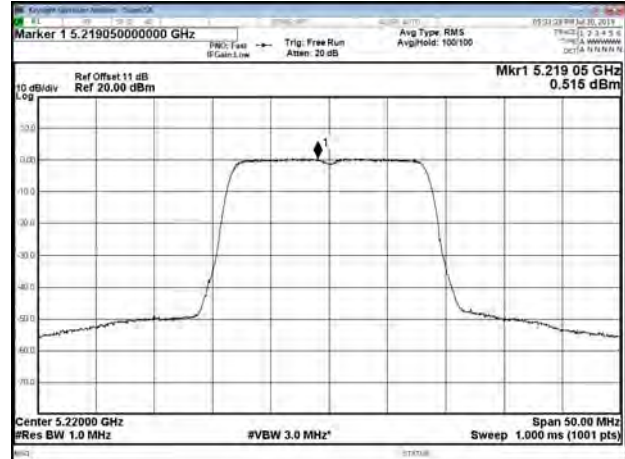

Modulation Standard: 802.11ac,VHT80
CH42

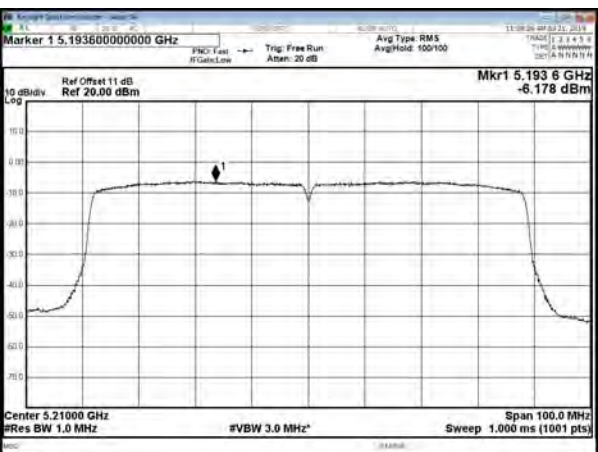

CH48

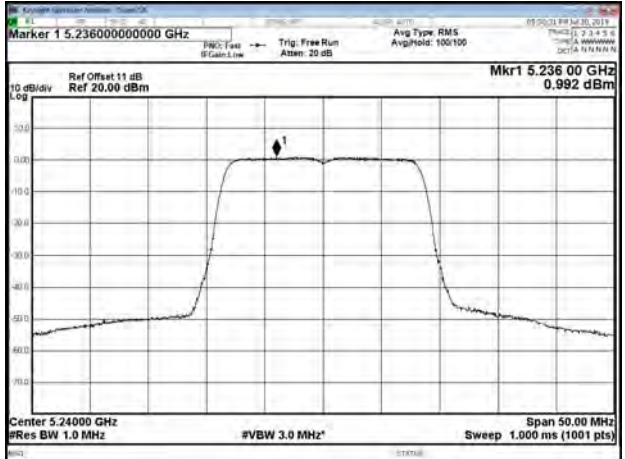



Modulation Standard: 802.11ac,VHT20
CH36

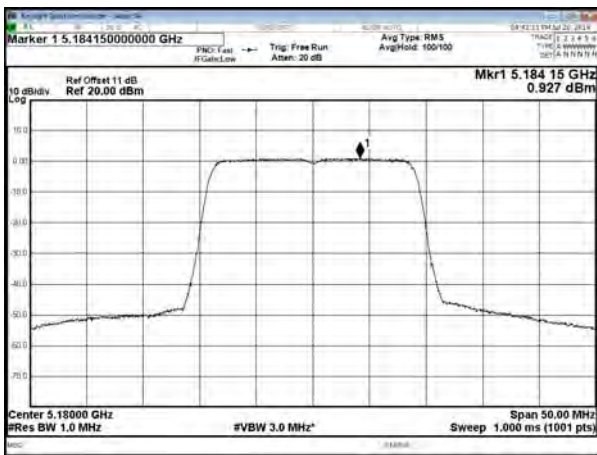

Modulation Standard: 802.11ac,VHT40
CH38

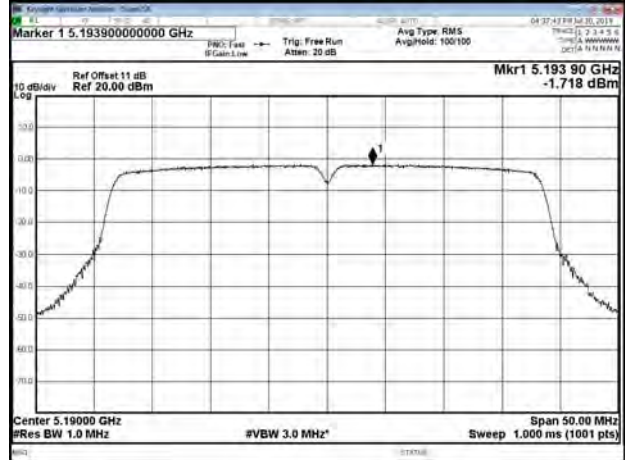

CH44

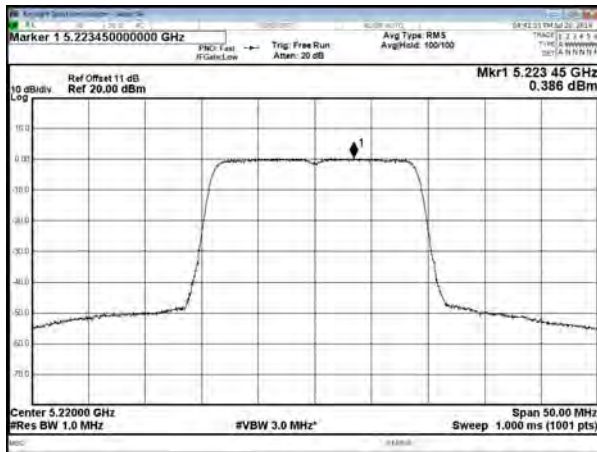

CH46

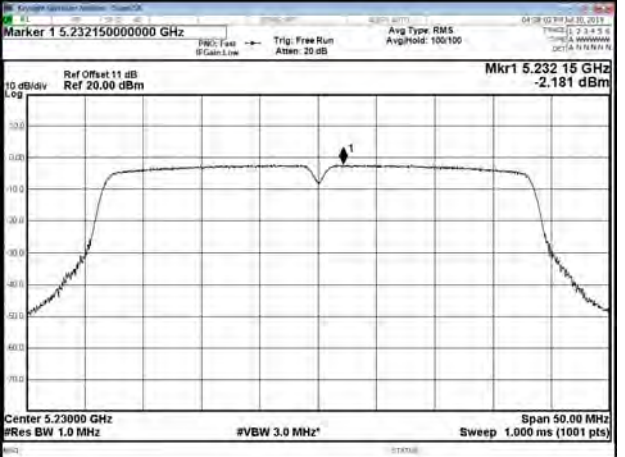

Modulation Standard: 802.11ac,VHT80

CH48

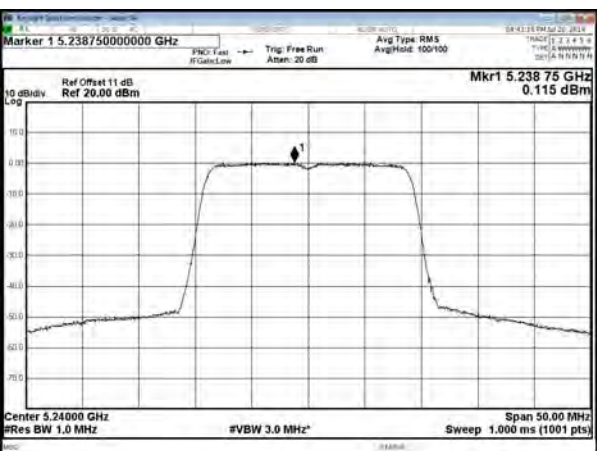

CH42

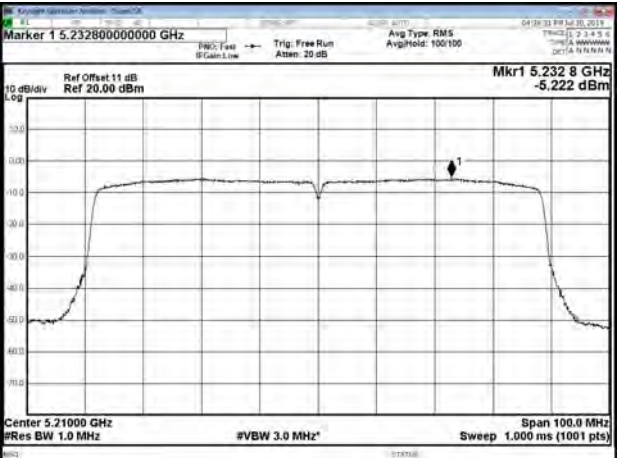



5.3G Band:
Chain 1
Modulation Standard: 802.11a
CH52

Modulation Standard: 802.11ac,VHT20
CH52

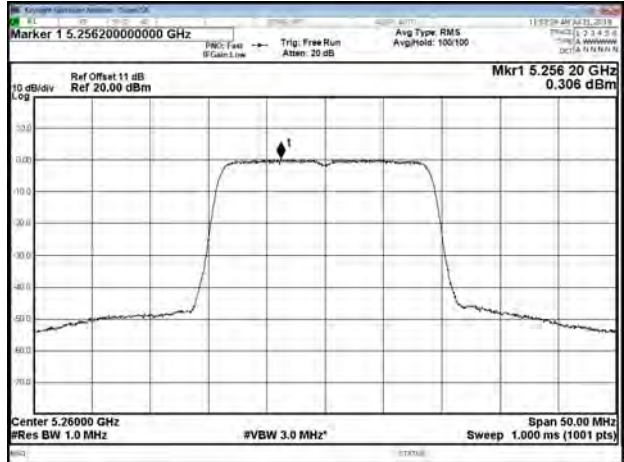
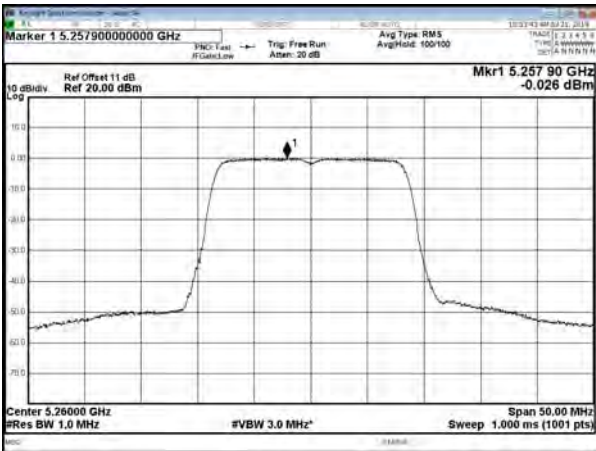

CH60

CH60

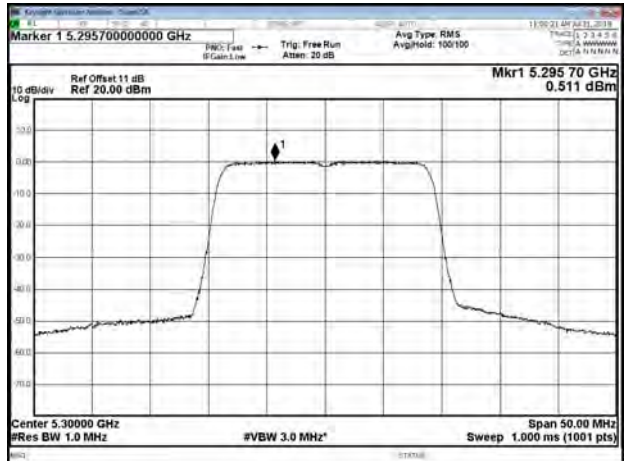
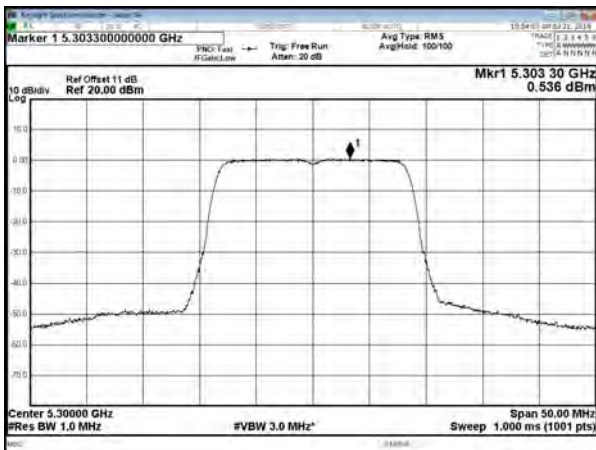

CH64

CH64

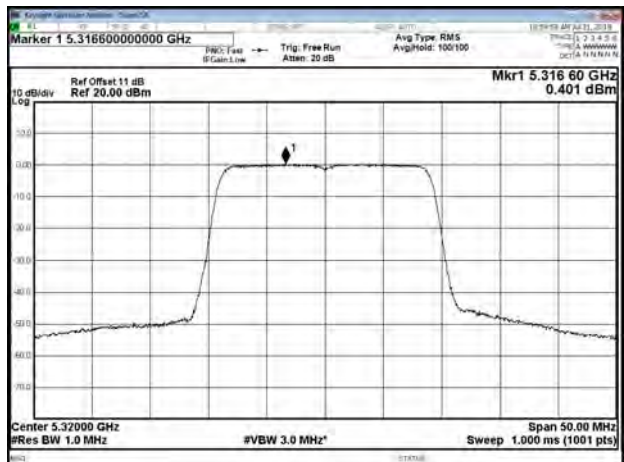
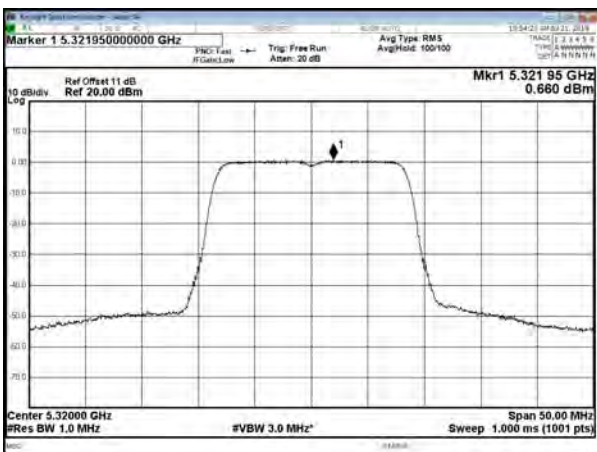



Modulation Standard: 802.11ac,VHT40
CH54

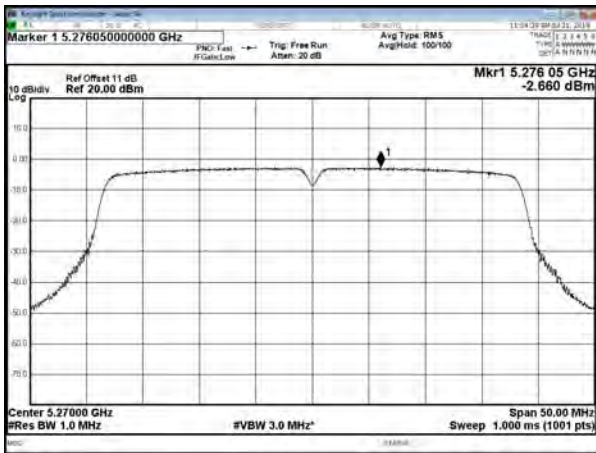

Chain 2
Modulation Standard: 802.11a
CH52

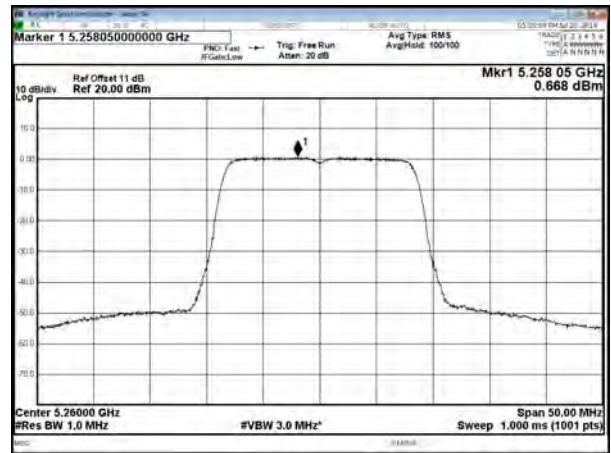

CH62

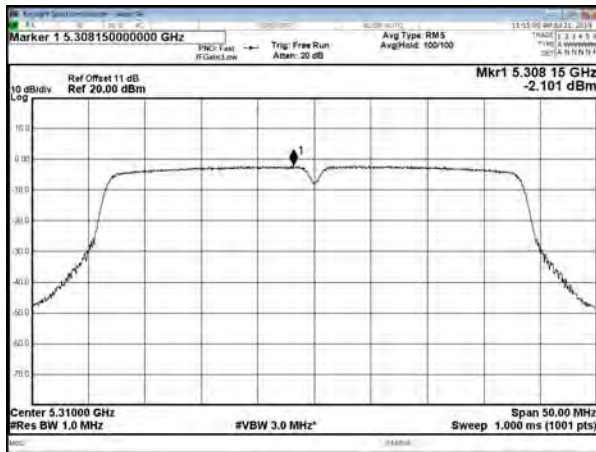

CH60

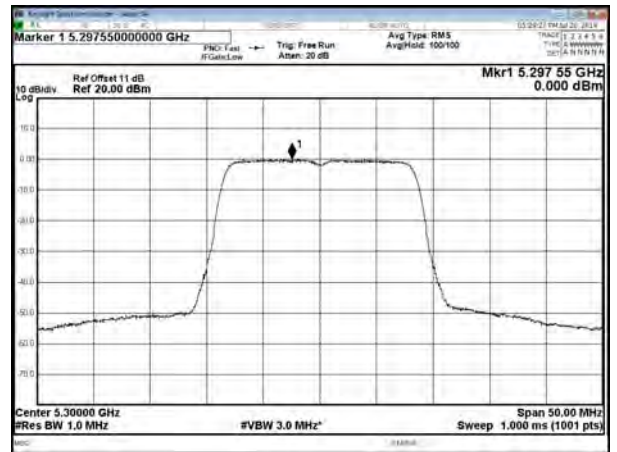

Modulation Standard: 802.11ac,VHT80
CH58

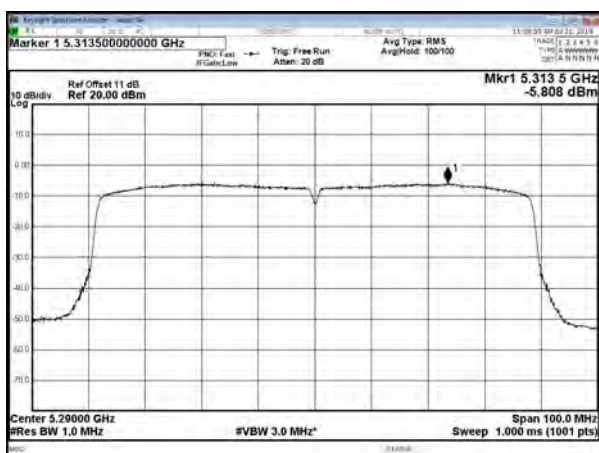

CH64

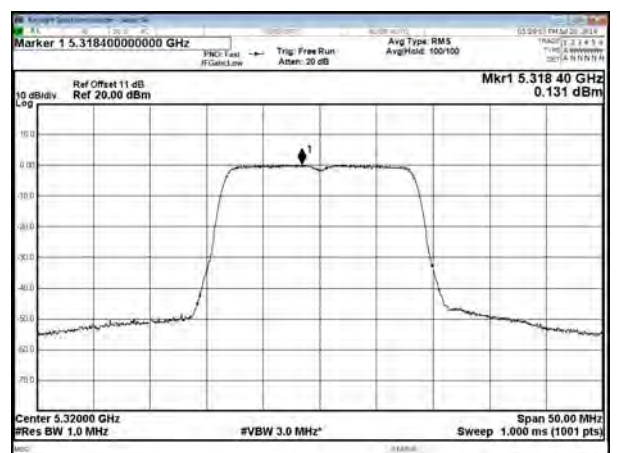



Modulation Standard: 802.11ac,VHT20
CH52

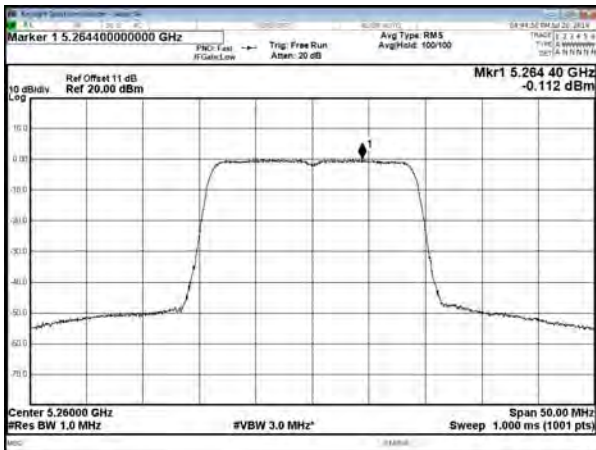

Modulation Standard: 802.11ac,VHT40
CH54

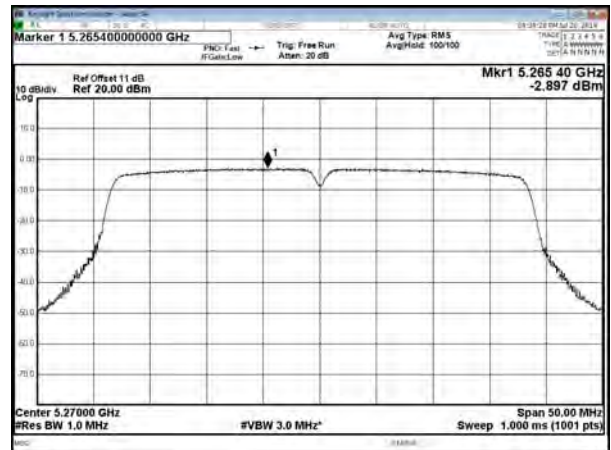

CH60

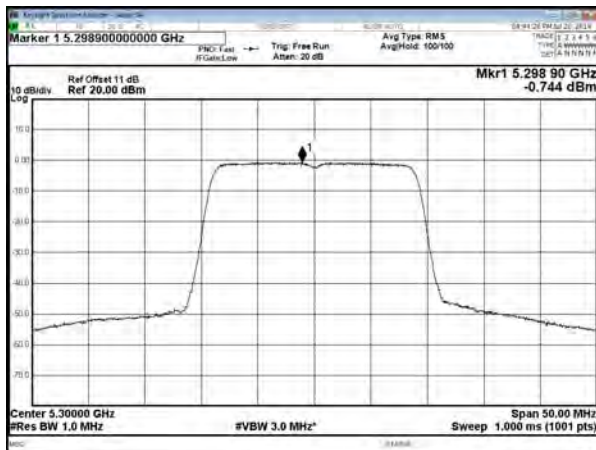

CH62

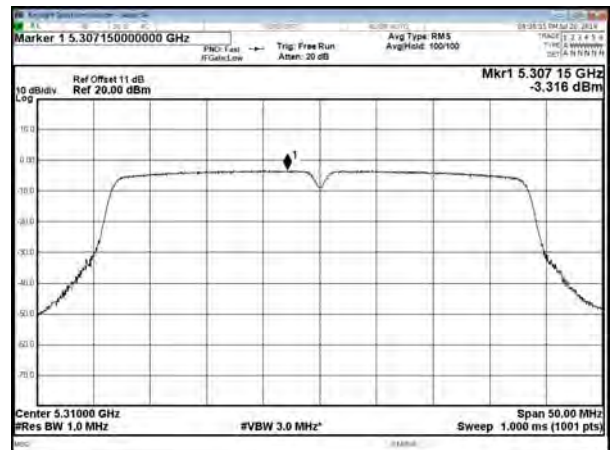

CH64

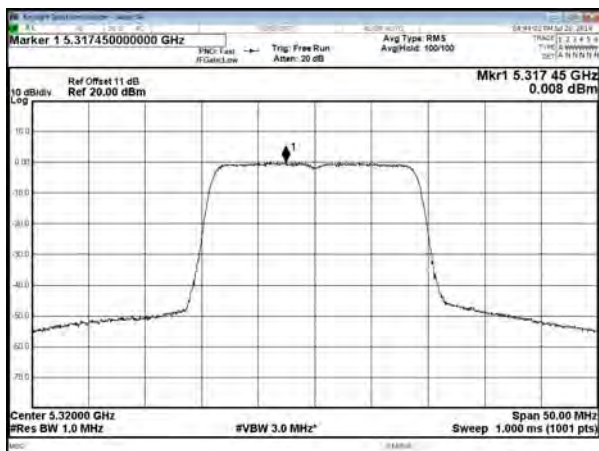

Modulation Standard: 802.11ac,VHT80
CH58

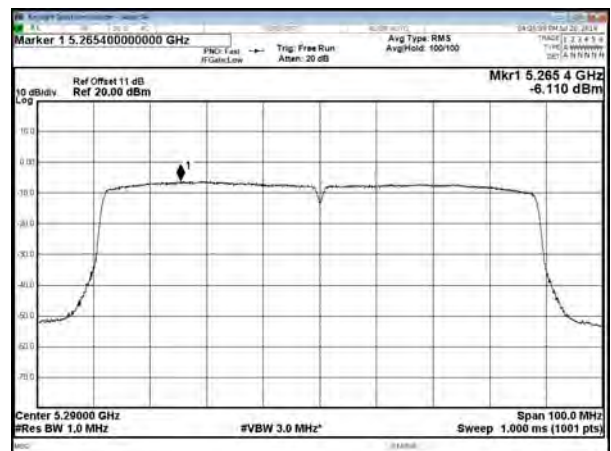



5.5G Band:
Chain 1
Modulation Standard: 802.11a
CH100

Modulation Standard: 802.11ac,VHT20
CH100

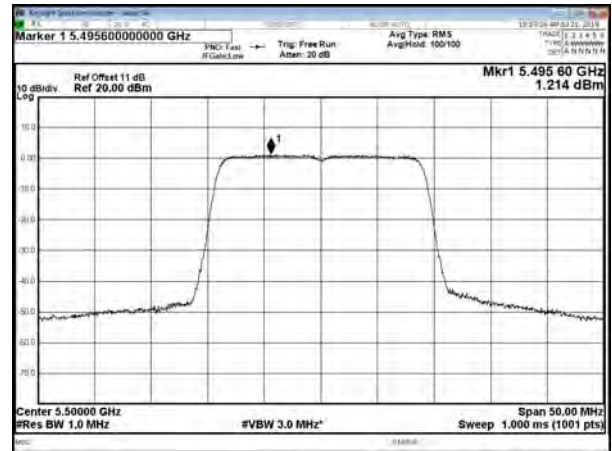
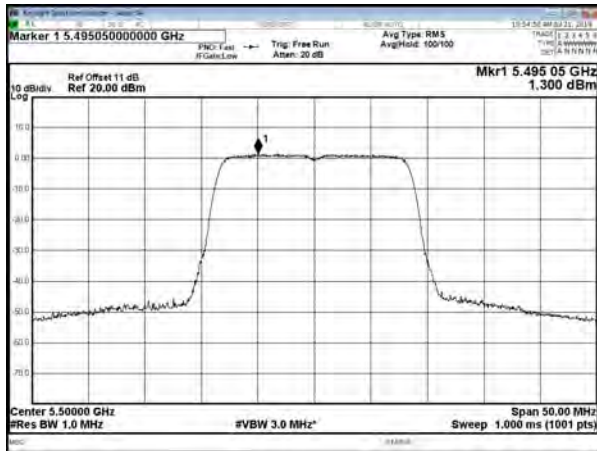

CH116

CH116

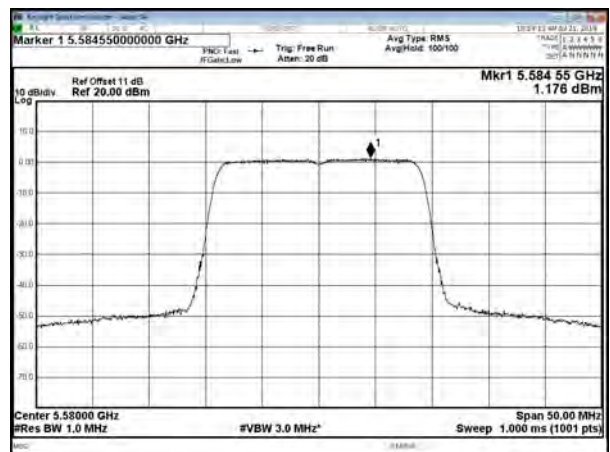
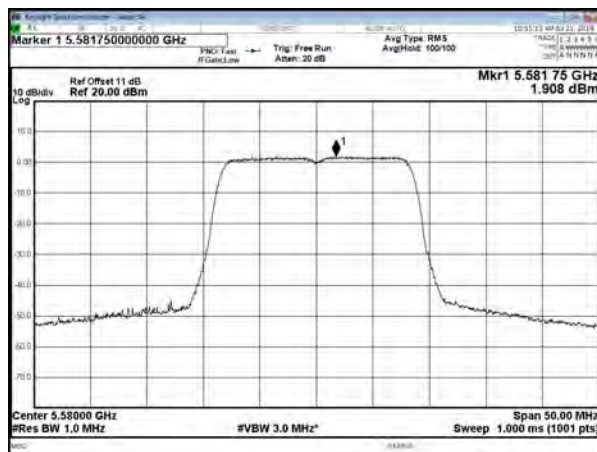

CH140

CH140

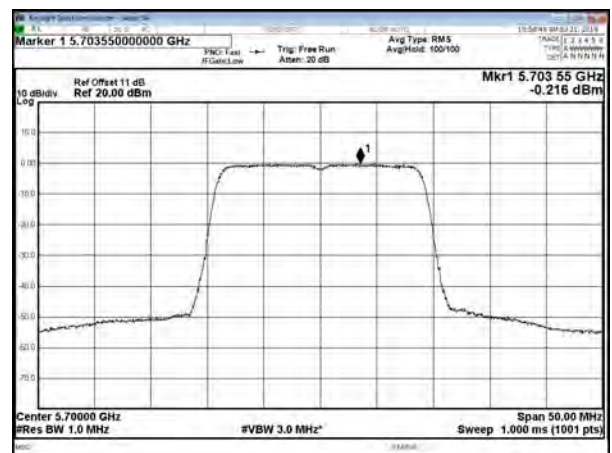
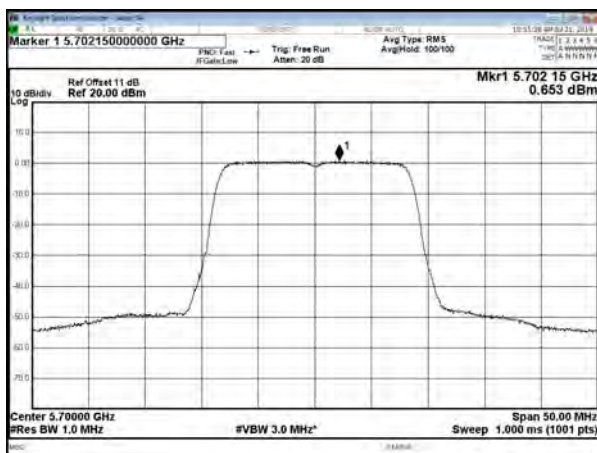



Modulation Standard: 802.11ac,VHT40
CH102

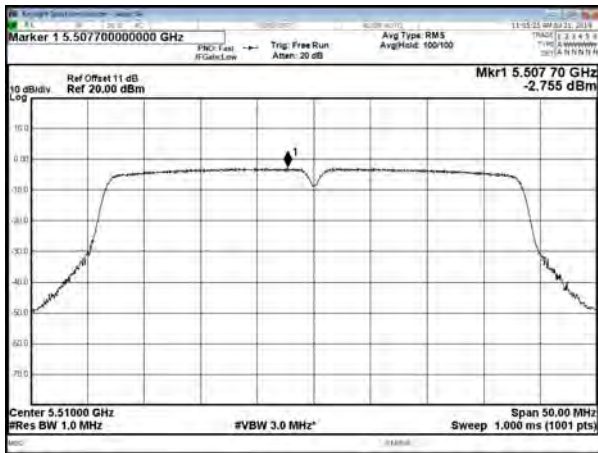

Modulation Standard: 802.11ac,VHT80
CH106

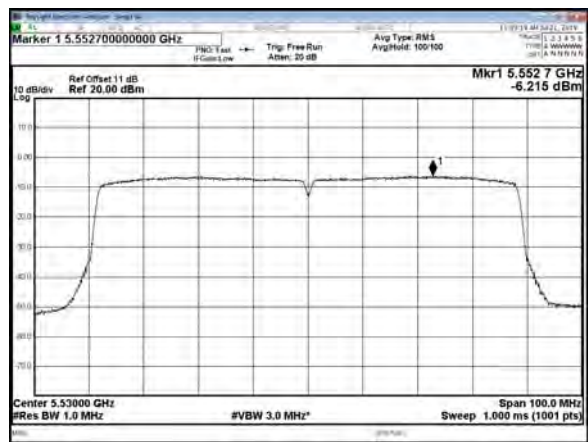

CH110

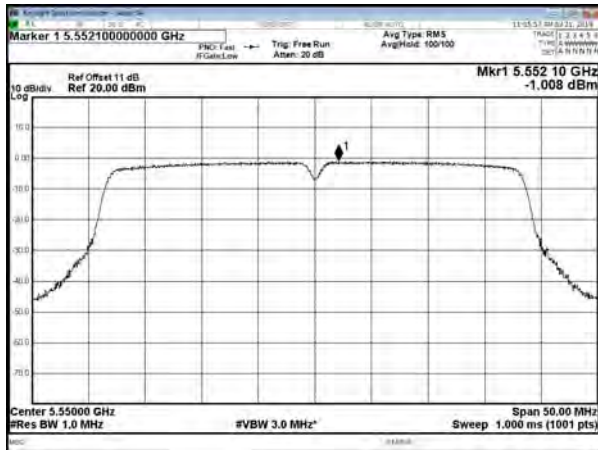

CH122

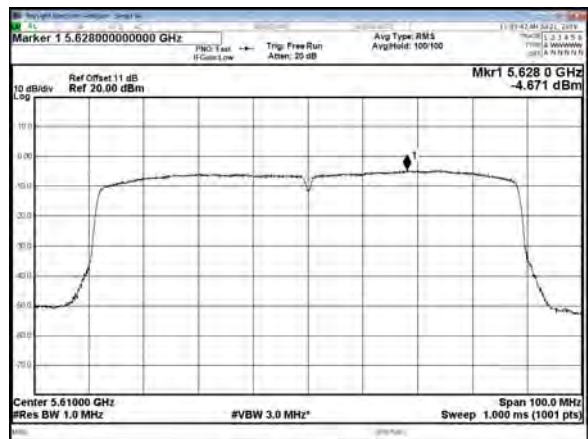

CH134

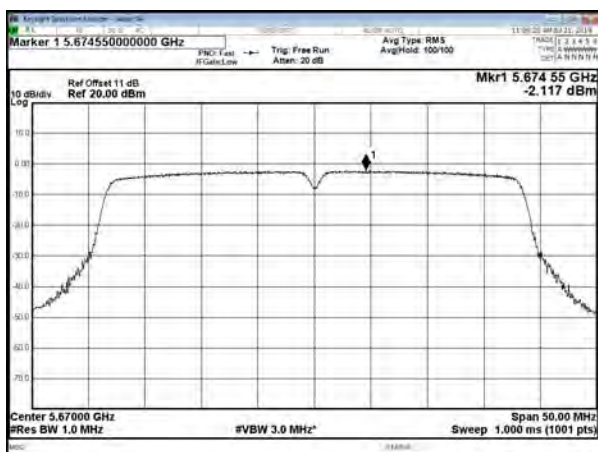



Chain 2
Modulation Standard: 802.11a
CH100

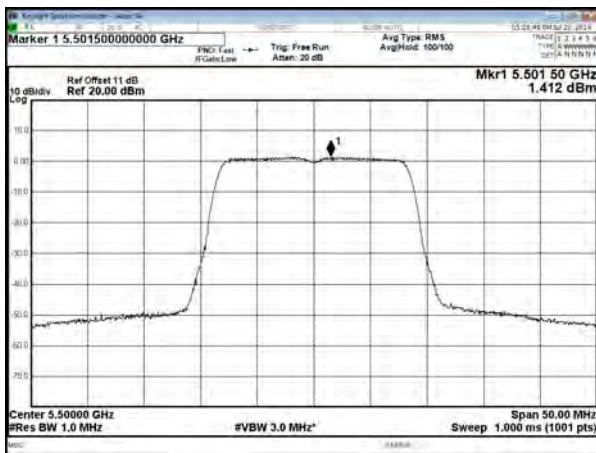

Modulation Standard: 802.11ac,VHT20
CH100

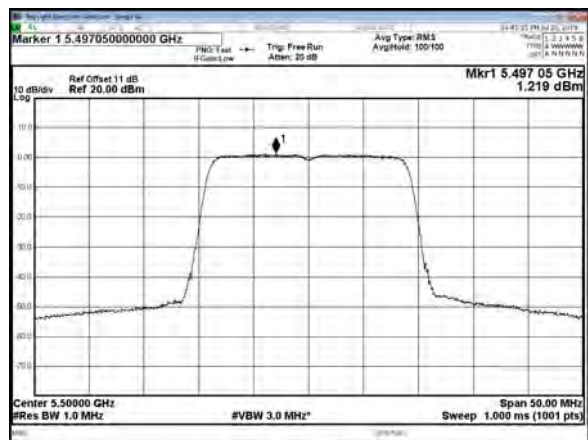

CH116

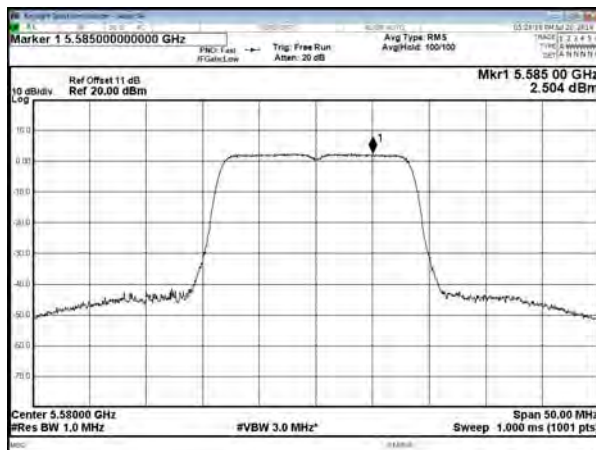

CH116

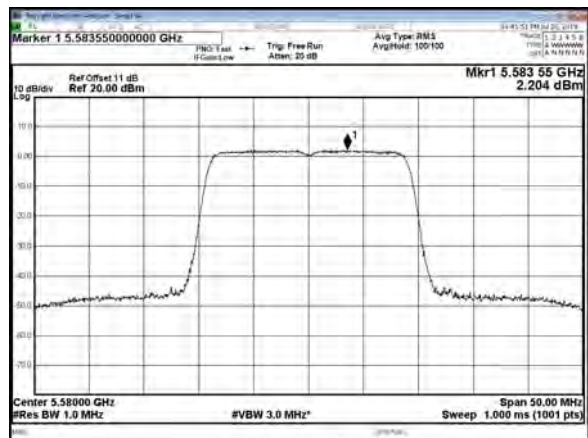

CH140

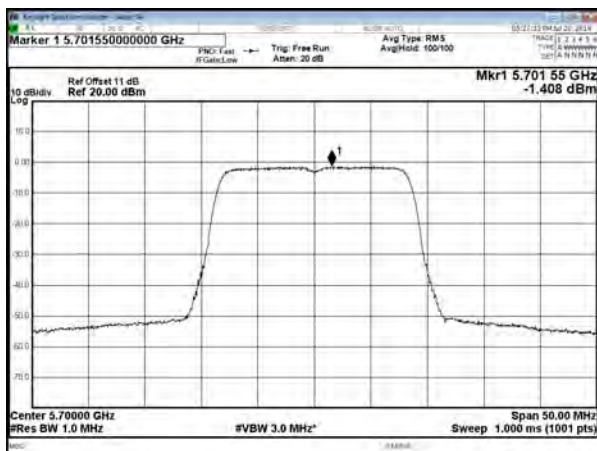

CH140

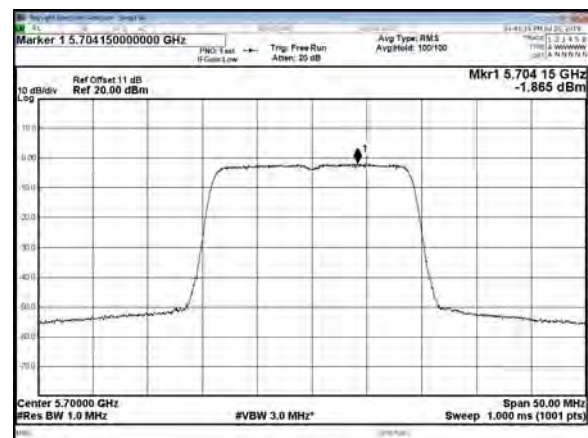



Modulation Standard: 802.11ac,VHT40
CH102

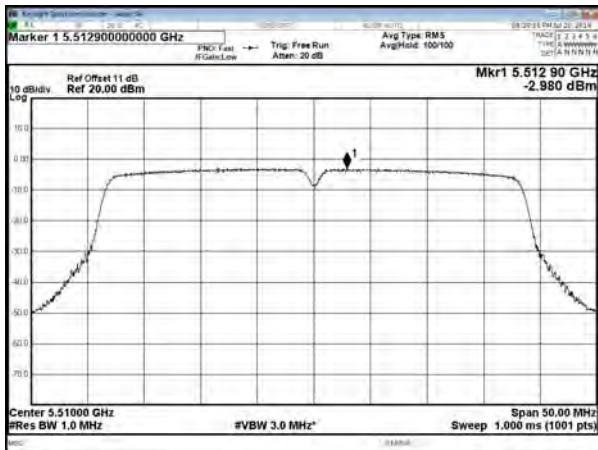

Modulation Standard: 802.11ac,VHT80
CH106

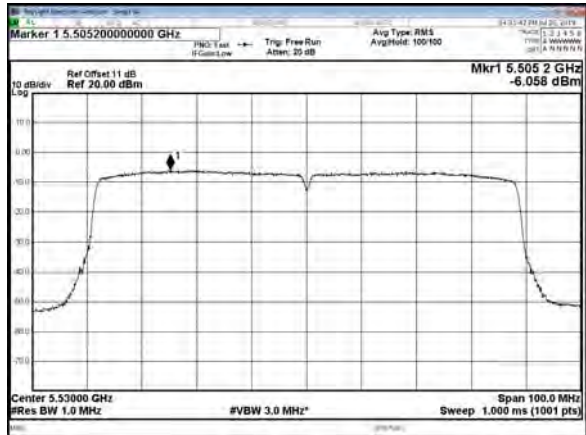

CH110

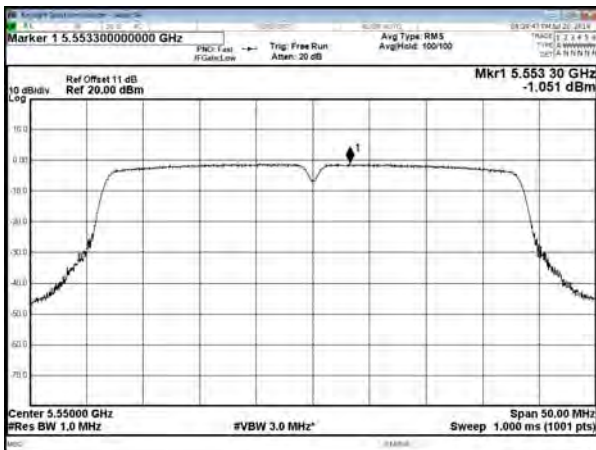

CH122

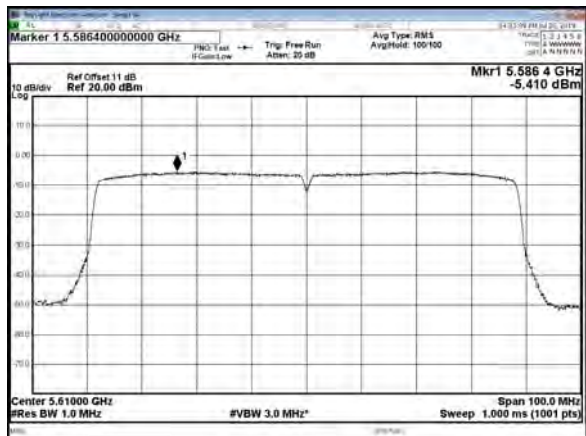

CH134

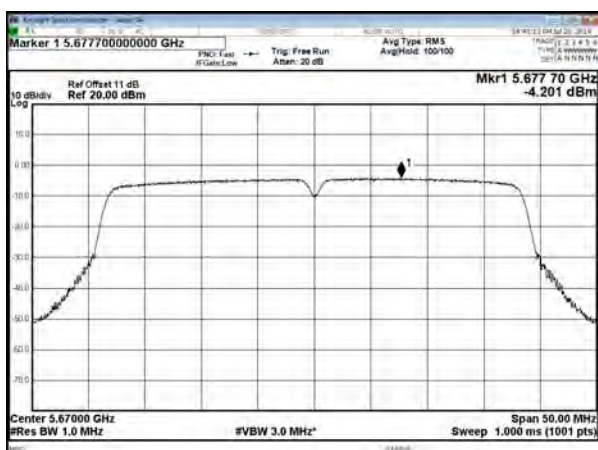



5.8G Band:
Chain 1
Modulation Standard: 802.11a
CH149

Modulation Standard: 802.11ac,VHT20
CH149

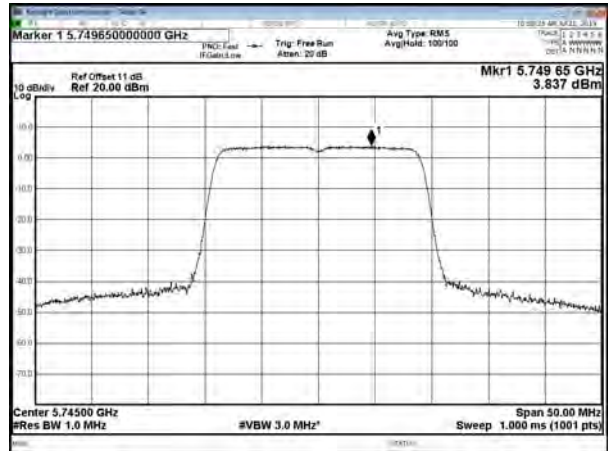
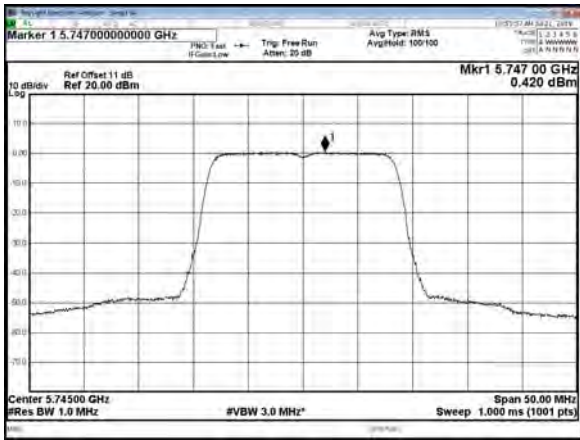

CH157

CH157

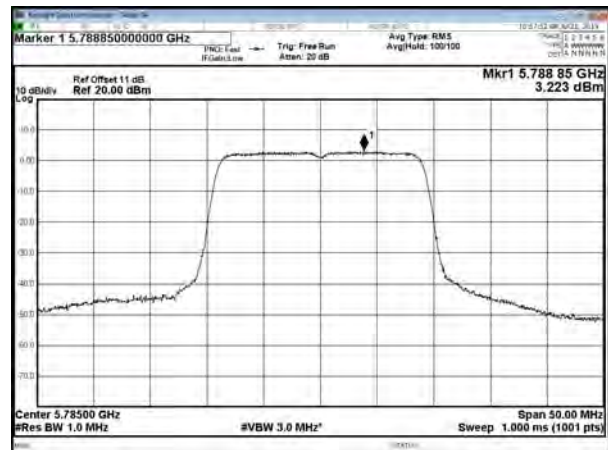
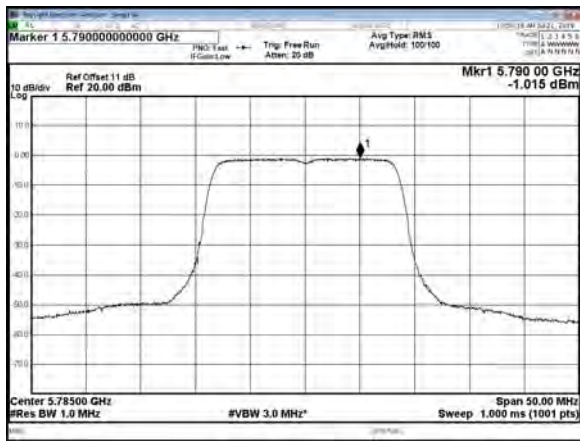

CH165

CH165

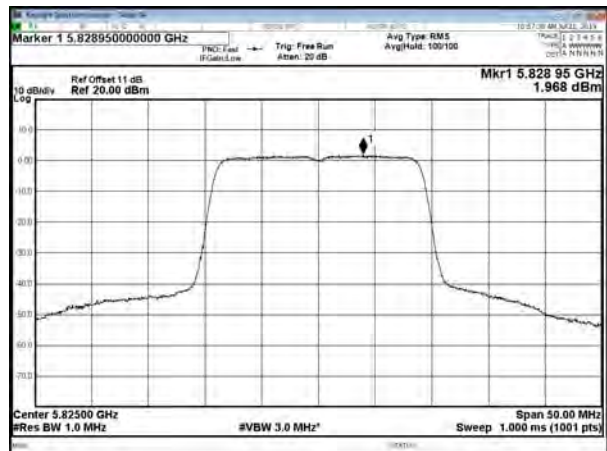
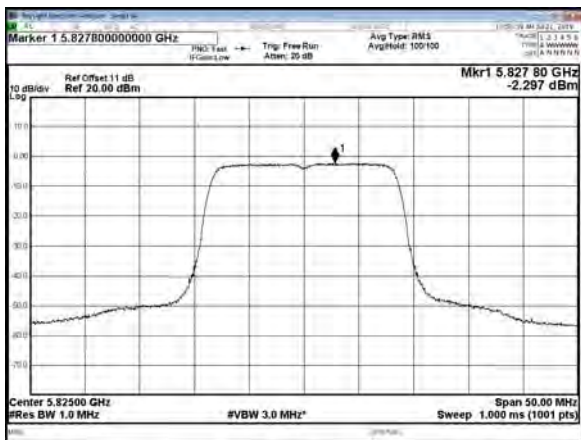



Modulation Standard: 802.11ac,VHT40
CH151

Chain 2
Modulation Standard: 802.11a
CH149

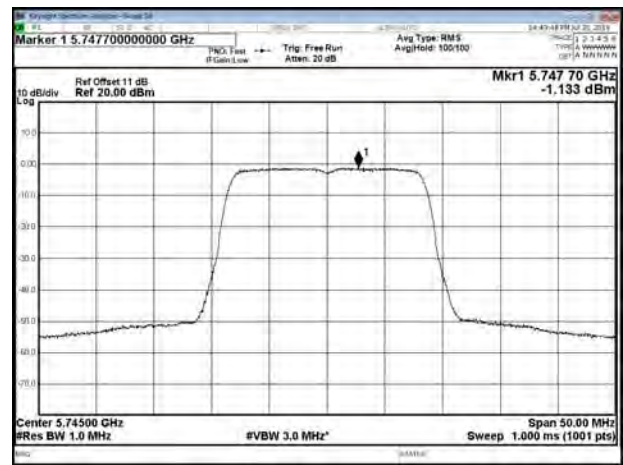
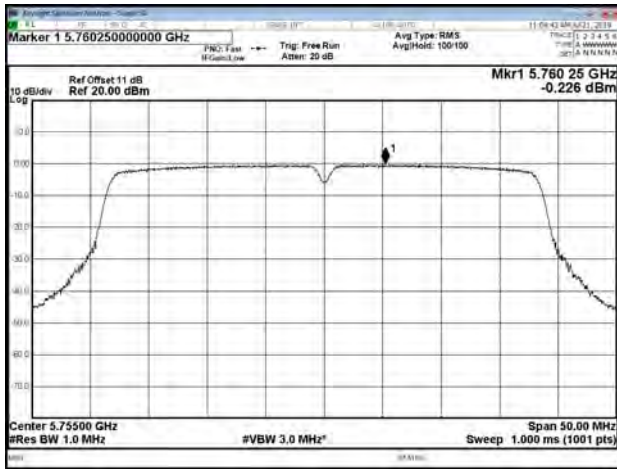

CH159

CH157

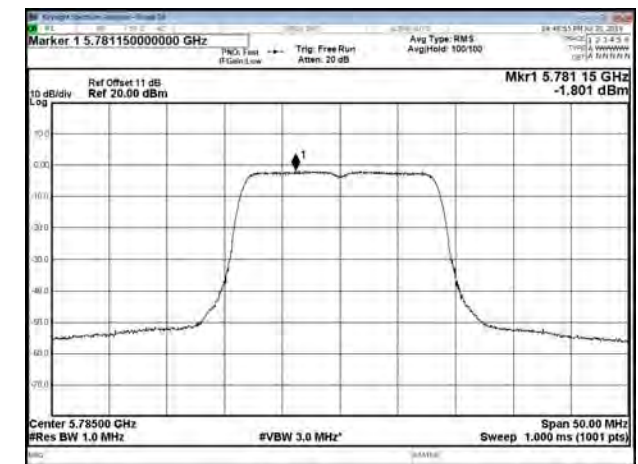
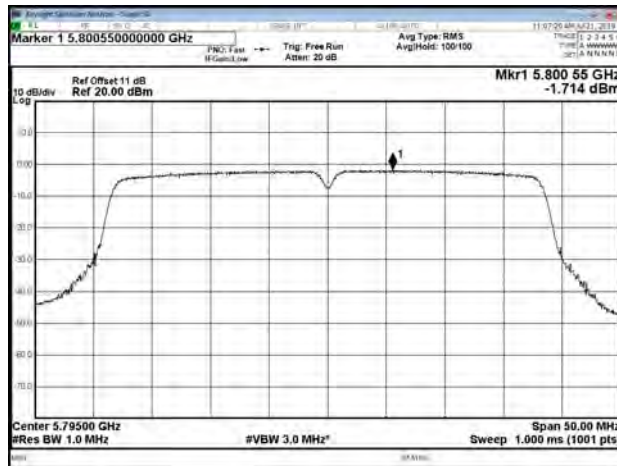

Modulation Standard: 802.11ac,VHT80
CH155

CH165

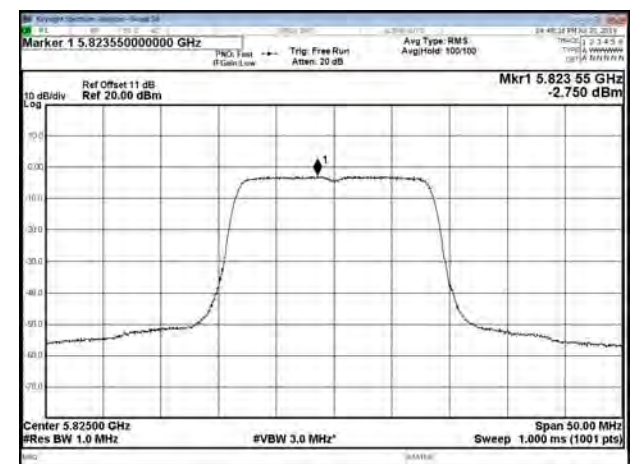
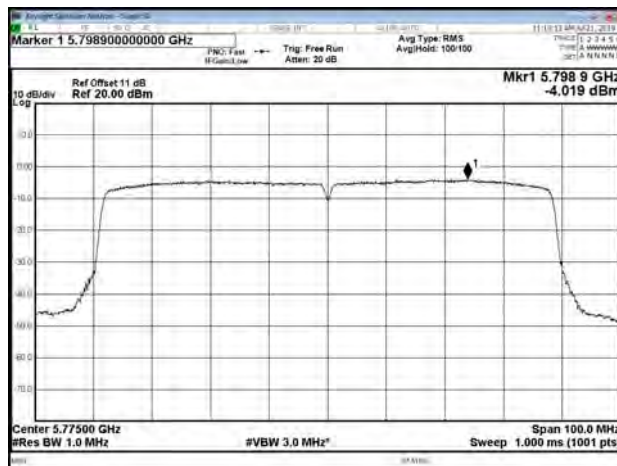



Modulation Standard: 802.11ac,VHT20
CH149

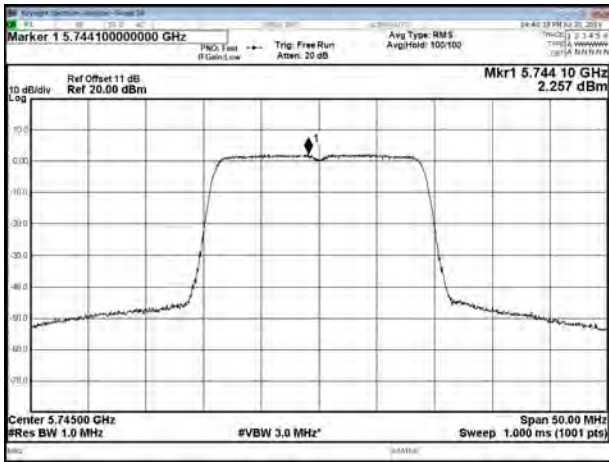

Modulation Standard: 802.11ac,VHT40
CH151

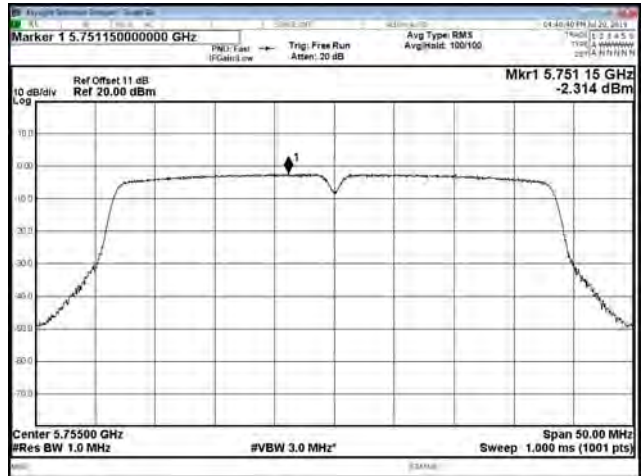

CH157

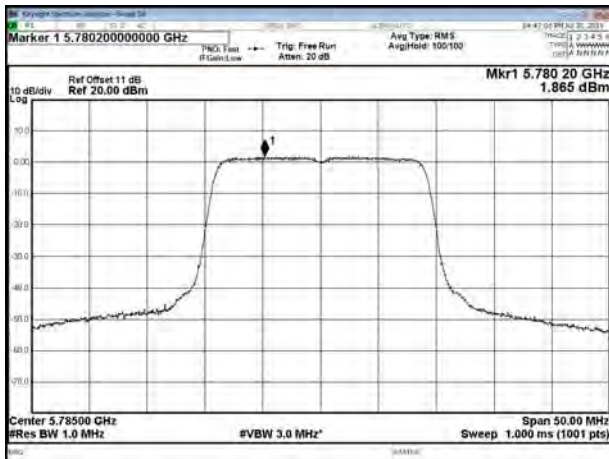

CH159

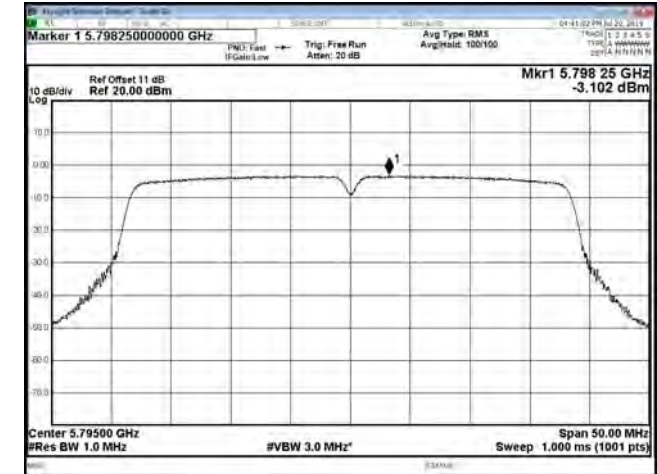

CH165

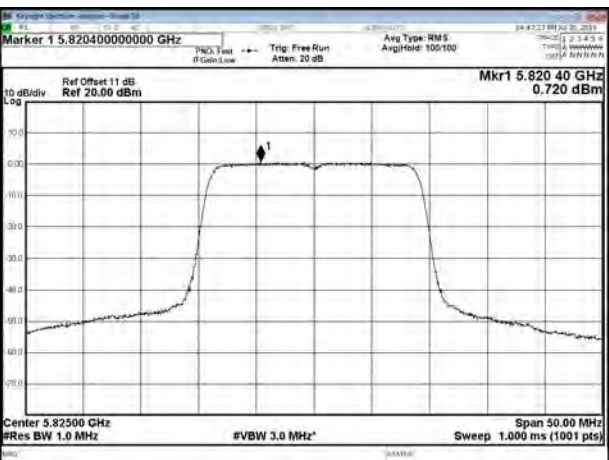

Modulation Standard: 802.11ac,VHT80

CH155

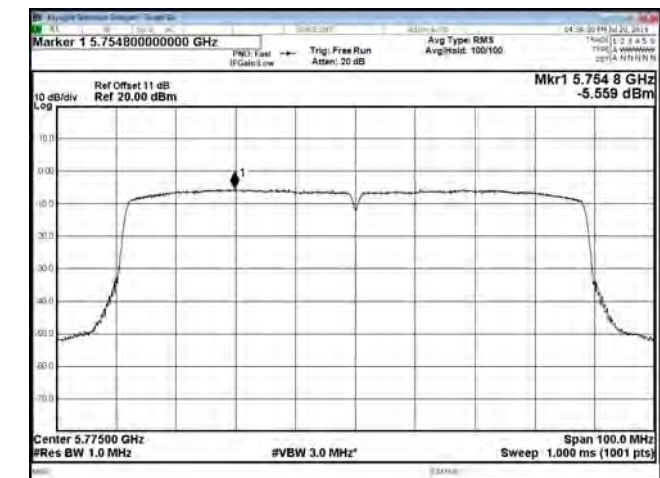



12. Frequency Stability

12.1. Test Procedure

1. The EUT was placed inside the Temperature and Humidity chamber.
2. The transmitter output was connected to spectrum analyzer.
3. Turn the EUT on and couple its output to a spectrum analyzer.
4. Turn the EUT off and set the chamber to the highest temperature specified.
5. Allow sufficient time (approximately 30 min) for the temperature of the chamber to stabilize, turn the EUT on and measure the operating frequency after 2, 5, and 10 minutes.
6. Repeat step 2 and 3 with the temperature chamber set to the lowest temperature.
7. The test chamber was allowed to stabilize at +20 degree C for a minimum of 30 minutes. The supply voltage was then adjusted on the EUT from 85% to 115% and the frequency record.

12.2. Test Setup Layout

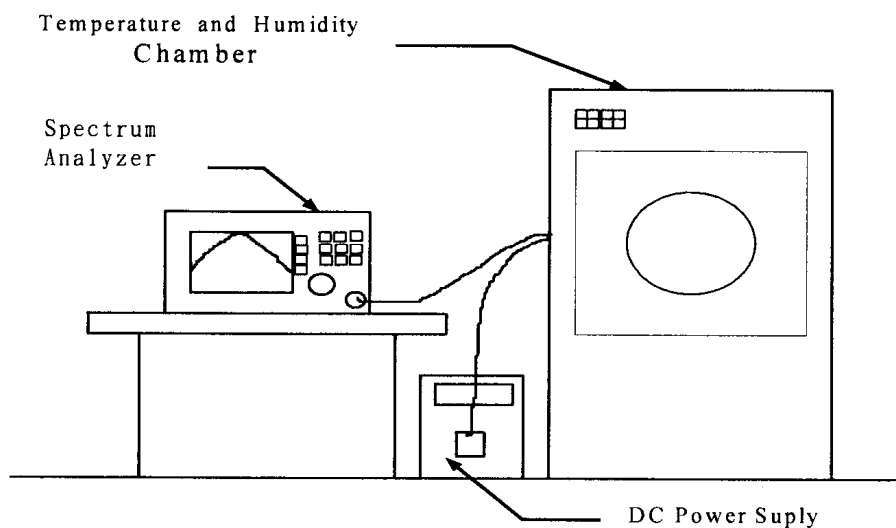



12.3.Test Result and Data

Temperature: 21°C

Humidity: 58%

Test Date: Jul. 20, 2019

Operating frequency: 5240 MHz							
Temp	Power supply	2 minute		5 minute		10 minute	
(°C)	(V)	(MHz)	(%)	(MHz)	(%)	(MHz)	(%)
40	3.6	5240.0912	0.001740	5240.1554	0.002966	5240.1556	0.029695
	3.3	5240.0924	0.001763	5240.1556	0.002969	5240.1554	0.029656
	3.0	5240.0928	0.001771	5240.1552	0.002962	5240.1548	0.029542
30	3.6	5240.0866	0.001653	5240.1542	0.002943	5240.1532	0.029237
	3.3	5240.0854	0.001630	5240.1543	0.002945	5240.1540	0.029389
	3.0	5240.0863	0.001647	5240.1546	0.002950	5240.1538	0.029351
20	3.6	5240.0543	0.001036	5240.1504	0.002870	5240.1512	0.028855
	3.3	5240.0462	0.000882	5240.1526	0.002912	5240.1496	0.028550
	3.0	5240.0512	0.000977	5240.1518	0.002897	5240.1524	0.029084
10	3.6	5240.0424	0.000809	5240.1052	0.002008	5240.1120	0.021374
	3.3	5240.0436	0.000832	5240.1048	0.002000	5240.1124	0.021450
	3.0	5240.0428	0.000817	5240.1046	0.001996	5240.1088	0.020763
0	3.6	5240.0242	0.000462	5240.0684	0.001305	5240.0712	0.013588
	3.3	5240.0257	0.000490	5240.0688	0.001313	5240.0698	0.013321
	3.0	5240.0264	0.000504	5240.0696	0.001328	5240.0692	0.013206

Limit:

Manufacturers of U-NII devices are responsible for ensuring frequency stability such that an emission is maintained within the band of operation under all conditions of normal operation as specified in the users manual.



13. Automatically Discontinue Transmission

13.1.Limit of Automatically Discontinue Transmission

The device shall automatically discontinue transmission in case of either absence of information to transmit or operational failure. These provisions are not intended to preclude the transmission of control or signaling information or the use of repetitive codes used by certain digital technologies to complete frame or burst intervals. Applicants shall include in their application for equipment authorization to describe how this requirement is met.

13.2.Test Result of Automatically Discontinue Transmission

While the EUT is not transmitting any information, the EUT can automatically discontinue transmission and become standby mode for power saving. The EUT can detect the controlling signal of ACK message transmitting from remote device and verify whether it shall resend or discontinue transmission.



14. Dynamic Frequency Selection

14.1. List of Measurement and Examinations

EUT Applicability of DFS requirements and Frequency Range

Operation Mode		Operating Frequency Range	
		5250-5350MHz	5470-5725MHz (5600MHz-5650MHz will be disable)
Master	--	--	--
Client without radar detection	√	√	√
Client with radar detection	--	--	--

DEVICES WITH RADAR DETECTION

MAXIMUM TRANSMIT POWER	VALUE (SEE Note 1 and 2)
≥ 200 milliwatt	-64 dBm
EIRP < 200 milliwatt and power spectral density < 10 dBm/MHz	-62 dBm
EIRP < 200 milliwatt that do not meet the power spectral density requirement	-64 dBm

Note 1: This is the level at the input of the receiver assuming a 0 dBi receive antenna.
 Note 2: Throughout these test procedures an additional 1 dB has been added to the amplitude of the test transmission waveforms to account for variations in measurement equipment. This will ensure that the test signal is at or above the detection threshold level to trigger a DFS response.
 Note3: EIRP is based on the highest antenna gain. For MIMO devices refer to KDB Publication 662911

Table1: Applicability of DFS requirements prior to use of a channel

REQUIREMENT RADAR	OPERATIONAL MODE		
	MASTER	CLIENT WITHOUT RADAR DETECTION	CLIENT WITH RADAR DETECTION
Non-Occupancy Period	V	V _{Note}	V
DFS Detection Threshold	V	Not required	V
Channel Availability Check Time	V	Not required	Not required
U-NII Detection Bandwidth	V	Not required	V

Note: Regarding KDB 905462 D03 Client Without DFS New Rules section (b)(5/6),
 If the client moves with the master, the device is considered compliant if nothing appears in the client non-occupancy period test. For devices that shut down (rather than moving channels), no beacons should appear. An analyzer plot that contains a single 30-minute sweep on the original channel.

**Table2: Applicability of DFS requirements during normal operation**

REQUIREMENT RADAR	OPERATIONAL MODE		
	MASTER	CLIENT WITHOUT RADAR DETECTION	CLIENT WITH RADAR DETECTION
DFS Detection Threshold	√	Not required	√
Channel Closing Transmission Time	√	√	√
Channel Move Time	√	√	√
U-NII Detection Bandwidth	√	Not required	√

Additional requirements for devices with multiple bandwidth modes	Master or Client with radar detection	Client without radar detection
U-NII Detection Bandwidth and Statistical Performance Check	All BW modes must be tested	Not required
Channel Move Time and Channel Closing Transmission Time	Test using widest BW mode available	Test using the widest BW mode available for the link
All other	Any single BW mode	Not required

Note: Frequencies selected for statistical performance check (Section 7.8.4) should include several frequencies within the radar detection bandwidth and frequencies near the edge of the radar detection bandwidth. For 802.11 devices it is suggested to select frequencies in each of the bonded 20 MHz channels and the channel center frequency.



14.2. Test Setup

Setup for Master with injection at the Master

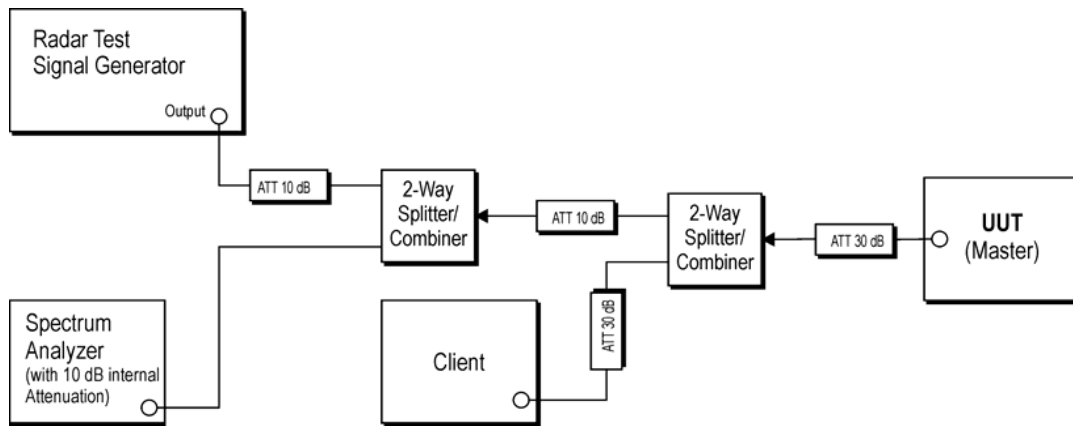

Figure 1: Example Conducted Setup where UUT is a Master and Radar Test Waveforms are injected into the Master

Setup for Client with injection at the Master

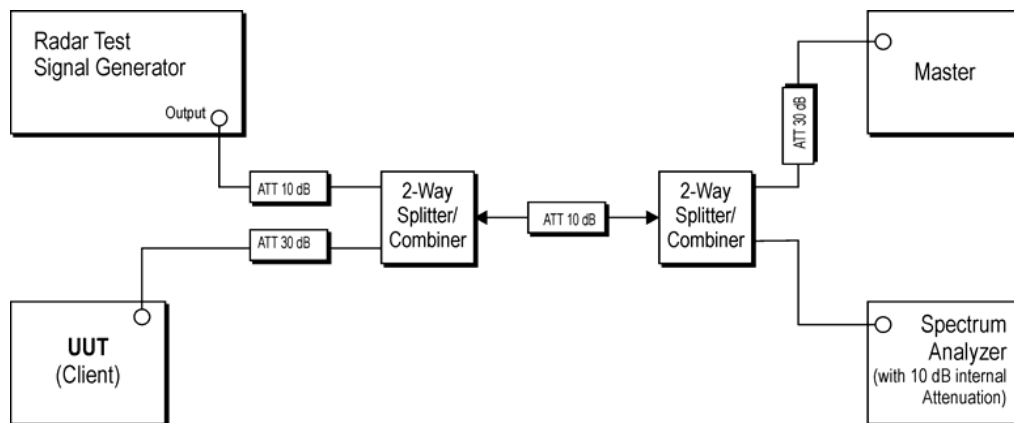

Figure 2: Example Conducted Setup where UUT is a Client and Radar Test Waveforms are injected into the Master



Setup for Client with injection at the Client

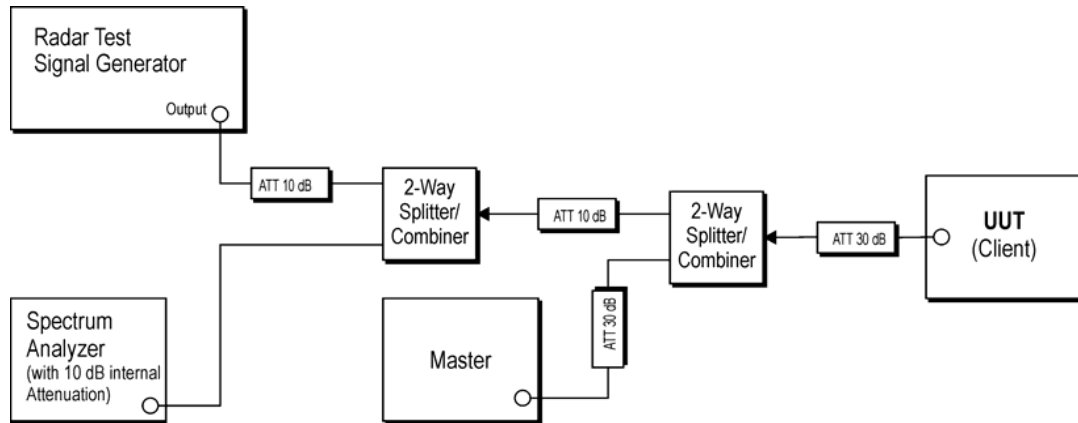

Figure 3: Example Conducted Setup where UUT is a Client and Radar Test Waveforms are injected into the Client



14.3. Non-Occupancy Period

The Channel Shutdown is defined as the process initiated by the RLAN device immediately after a radar signal has been detected on an Operating Channel.

The master device shall instruct all associated slave devices to stop transmitting on this channel, which they shall do within the Channel Move Time.

Slave devices with a Radar Interference Detection function, shall stop their own transmissions within the Channel Move Time.

The aggregate duration of all transmissions of the RLAN device on this channel during the Channel Move Time shall be limited to the Channel Closing Transmission Time. The aggregate duration of all transmissions shall not include quiet periods in between transmissions.

14.3.1. Test Limit

Radar Test Signal	Master (min)	Client (min)
0	> 30	> 30

14.3.2. Channel Loading

Timing plots are required with calculations demonstrating a minimum channel loading of approximately 17% or greater. For example, channel loading can be estimated by setting the spectrum analyzer for zero span and approximate the Time On/ (Time On + Off Time). This can be done with any appropriate channel BW and modulation type

Modulation Standard: 802.11ac VHT20

Time On/ (Time On + Off Time) = 6.318ms/15.522ms=40.7%

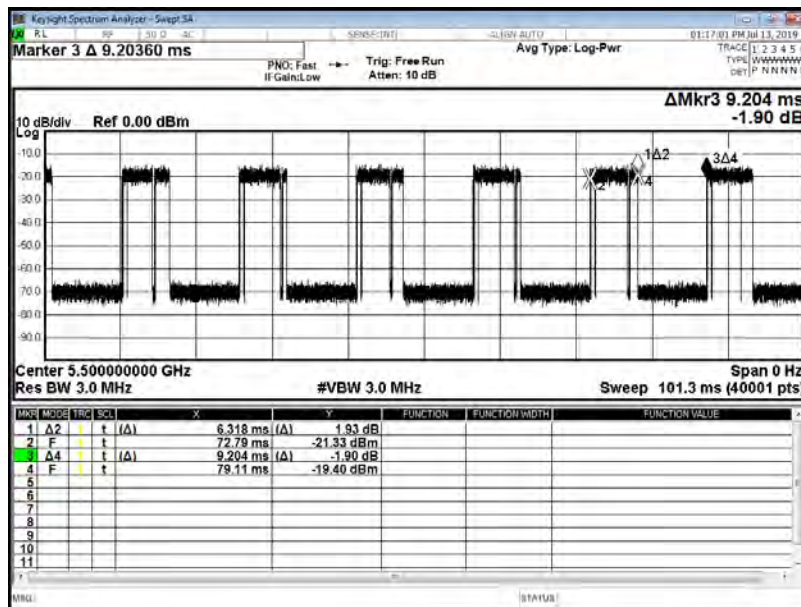



Modulation Standard: 802.11ac VHT80

Time On/ (Time On + Off Time) = 5.938ms/15.628ms=38%

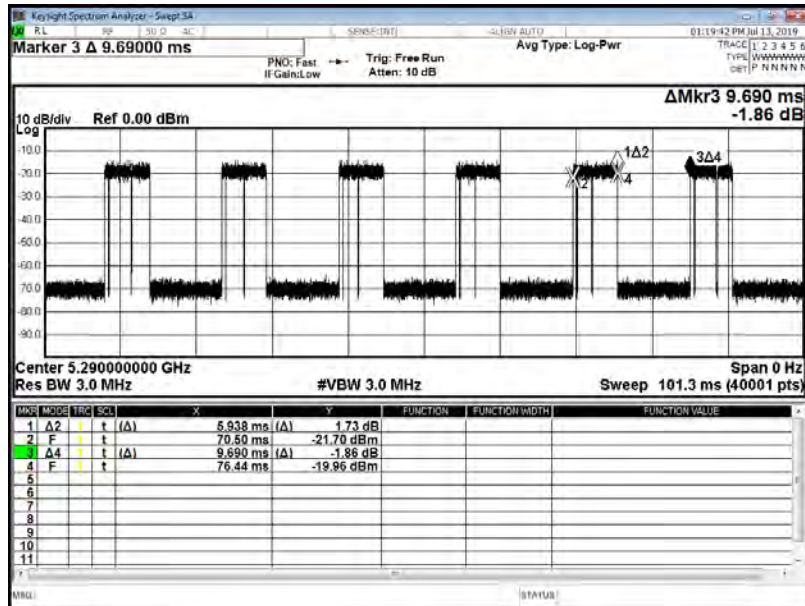



14.3.3. Test Result of Non-Occupancy Period

Modulation Standard: 802.11ac VHT20

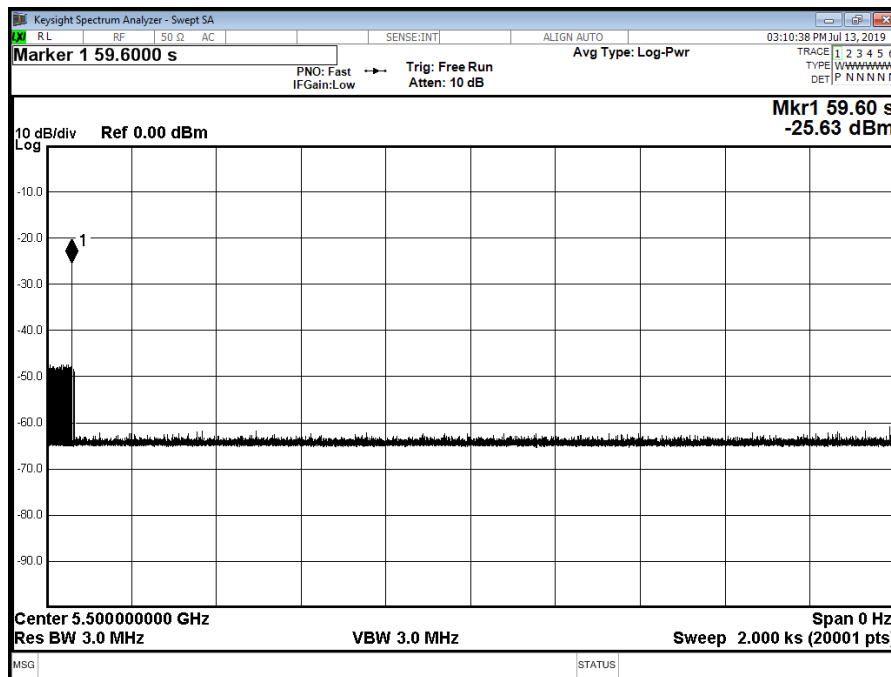

Modulation Standard: 802.11ac VHT80

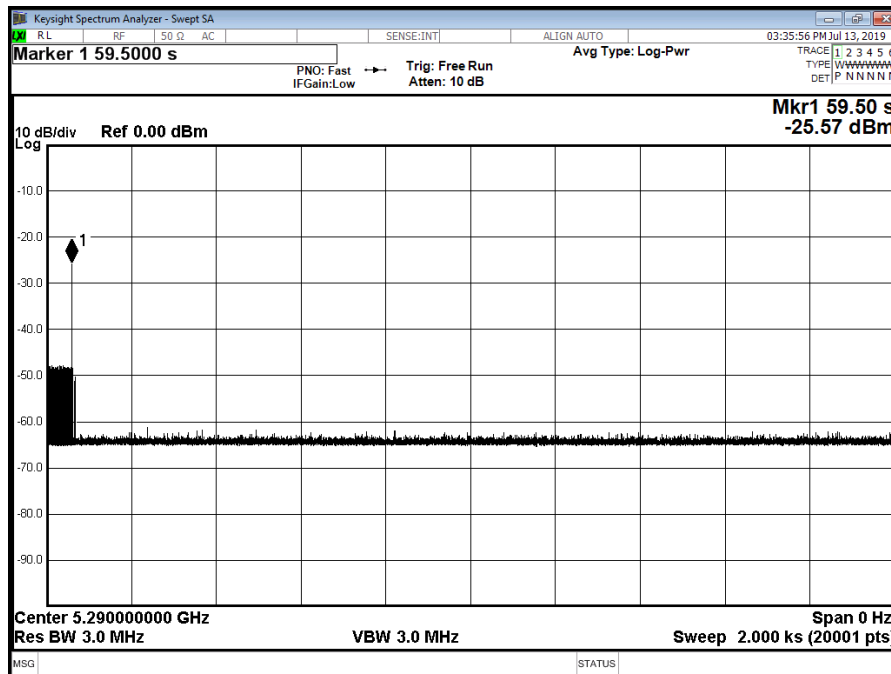



14.4.DFS Detection Threshold

DFS Detection Threshold is the level used by the DFS mechanism to detect radar interference.

14.4.1. Test Limit

Limits Clause 4.7.2.1.2

DFS Detection Thresholds for Master Devices and Client Devices with Radar Detection

MAXIMUM TRANSMIT POWER	VALUE (SEE Note 1 and 2)
≥ 200 milliwatt	-64 dBm
EIRP < 200 milliwatt and power spectral density < 10 dBm/MHz	-62 dBm
EIRP < 200 milliwatt that do not meet the power spectral density requirement	-64 dBm

Note 1: This is the level at the input of the receiver assuming a 0 dBi receive antenna.
 Note 2: Throughout these test procedures an additional 1 dB has been added to the amplitude of the test transmission waveforms to account for variations in measurement equipment. This will ensure that the test signal is at or above the detection threshold level to trigger a DFS response.
 Note3: EIRP is based on the highest antenna gain. For MIMO devices refer to KDB Publication 662911

14.4.2. Test Result of DFS Detection Threshold

EIRP < 200 milliwatt and power spectral density < 10 dBm/MHz, Radar 0 VALUE -62dBm

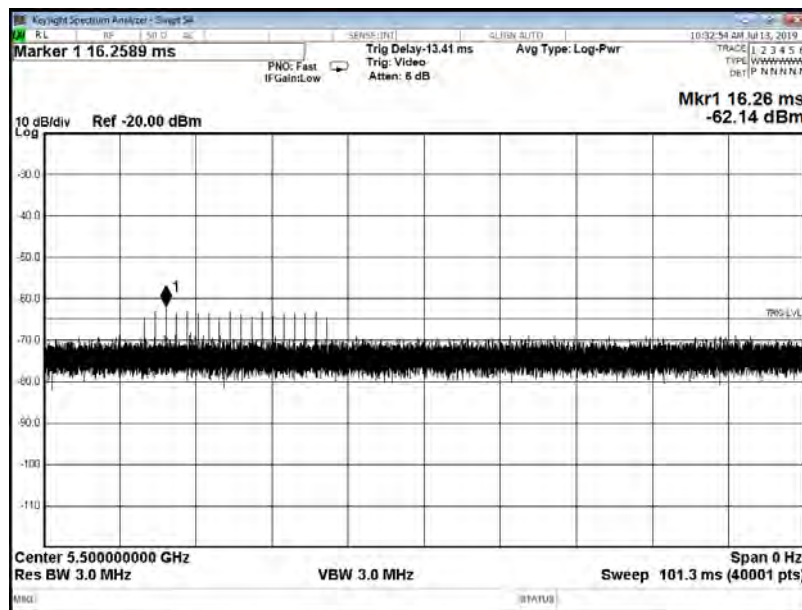



14.5.Channel Availability Check

The Channel Availability Check is defined as the mechanism by which an RLAN device checks a channel for the presence of radar signals.

There shall be no transmissions by the device within the channel being checked during this process. If no radars have been detected, the channel becomes an Available Channel valid for a period of time.

The RLAN shall only start transmissions on Available Channels.

At power-up, the RLAN is assumed to have no Available Channels.

14.5.1. Test Limit

Limits Clause 4.7.2.1.2

Table D.2: DFS requirement values

Parameter	Value
Channel Availability Check	> 60s

14.5.2. Test Result of Channel Availability Check

Not required



14.6.U-NII Detection Bandwidth

14.6.1. Test Limit

Limits Clause 4.7.2.1.2 Table D.2: DFS requirement values

Parameter	Value
U-NII Detection Bandwidth	Minimum 100% of the U-NII 99% transmission
Note : During the U-NII Detection Bandwidth detection test, radar type 0 should be used. For each frequency step the minimum percentage of detection is 90 percent. Measurements are performed with no data traffic.	

14.6.2. Test Result of U-NII Detection Bandwidth

Not required



14.7.Uniform Spreading

The UUT will select channel by random mode and remember this channel when detect radar signal, so that will select unused channel by random mode.

14.7.1. Test Result of Uniform Spreading

Not required



14.8.In-Service Monitoring

The In-Service Monitoring is defined as the process by which an RLAN monitors the Operating Channel for the presence of radar signals.

14.8.1. Test Limit

Parameter	Value
Channel Move Time	< 10 s (See Note 1)
Channel Closing Transmission Time	< 200 ms+ an aggregate of 60 milliseconds over remaining 10 second period. (See Notes 1 and Notes 2.)
Note 1: Channel Move Time and the Channel Closing Transmission Time should be performed with Radar Type 0. The measurement timing begins at the end of the Radar Type 0 burst. Note 2: The Channel Closing Transmission Time is comprised of 200 milliseconds starting at the beginning of the Channel Move Time plus any additional intermittent control signals required to facilitate a Channel move (an aggregate of 60 milliseconds) during the remainder of the 10 second period. The aggregate duration of control signals will not count quiet periods in between transmissions.	

Limits Clause 4.7.2.2.2

The In-Service Monitoring shall be used to continuously monitor an Operating Channel.

The In-Service-Monitoring shall start immediately after the RLAN has started transmissions on an Operating Channel.



14.8.2. Test Result of In-Service Monitoring

Signal 0 at 5500MHz, ac VHT20

	Value	Limit
Channel Move Time	7.7135s	<10 s
Channel Closing Transmission Time	15.19ms	< 200 ms

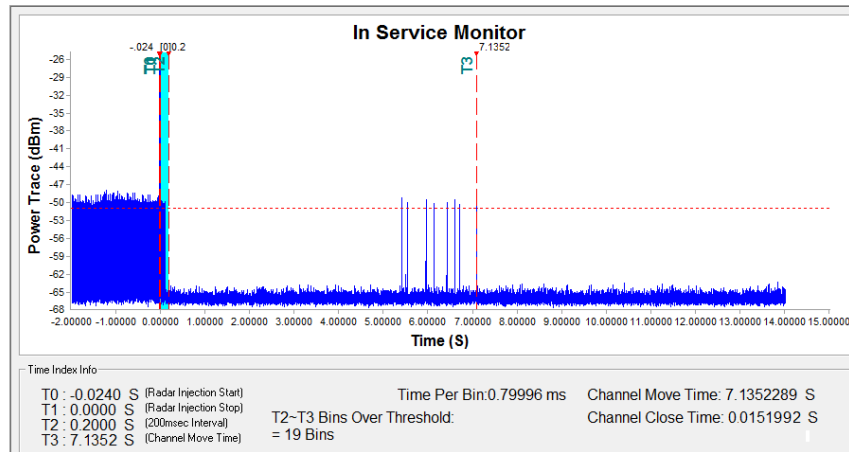

Signal 0 at 5290MHz, ac VHT80

	Value	Limit
Channel Move Time	5.2166s	<10 s
Channel Closing Transmission Time	8.80ms	< 200 ms

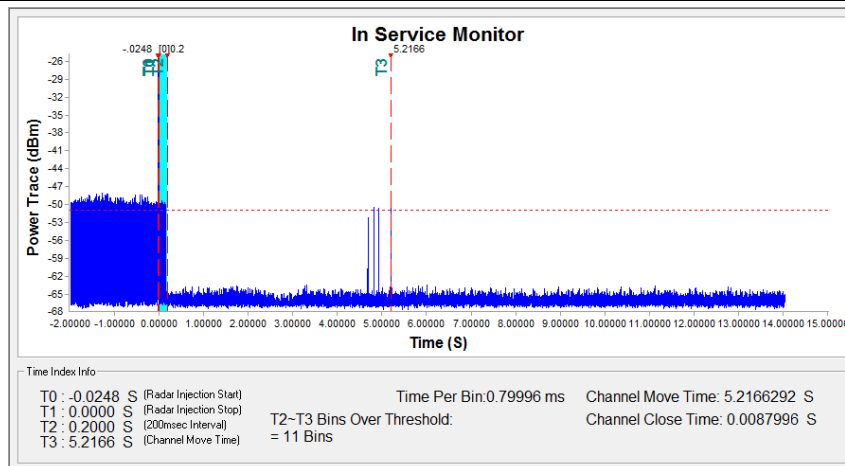

14.9. Statistical Performance Check

Not required



14.10. EUT Setup Photos

Radar Calibration Setup Photo

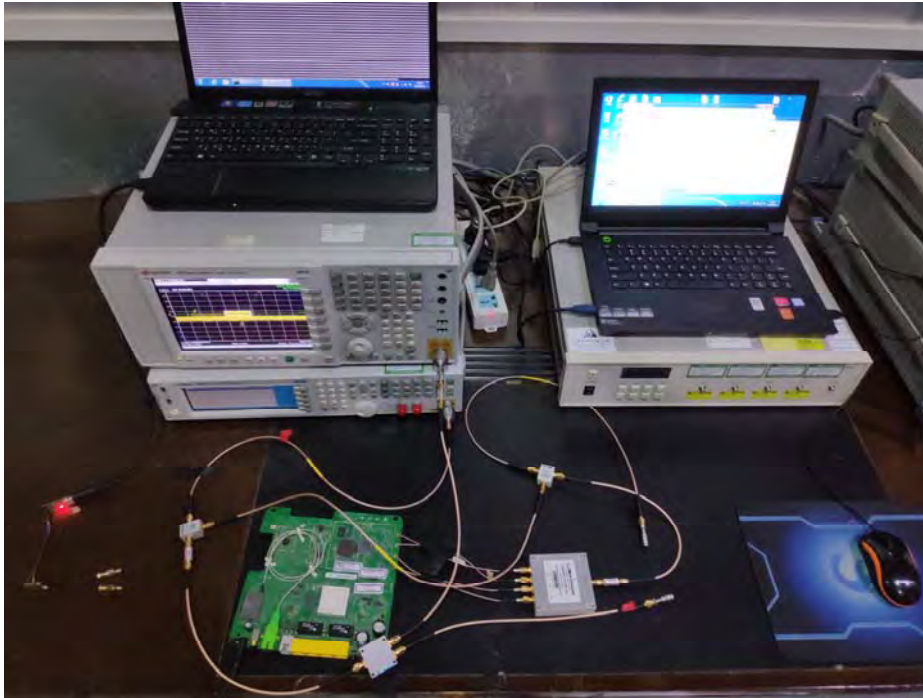

Test Setup Photo

