



FCC TEST REPORT

According to

CFR47 §15.247

Applicant : Guangzhou Shirui Electronics Co.,Ltd.
 Address : 192 Kezhu Road, Sciencetech Park, Guangzhou Economic & Technology
 Development District, Guangzhou,Guangdong,China
 Manufacturer : Guangzhou Shirui Electronics Co.,Ltd.
 Address : 192 Kezhu Road, Sciencetech Park, Guangzhou Economic & Technology
 Development District, Guangzhou,Guangdong,China
 Equipment : WiFi/BT Module
 Model No. : WF-R22C-USA1
 Brand : seewo
 FCC ID : 2AFG6-WF-R22C-USA1
 Test Period : Jul. 04, 2019~ Jul. 25, 2019

- The test result refers exclusively to the test presented test model / sample.
- Without written approval of **CerpPASS Technology (Suzhou) Co., Ltd.**, the test. report shall not be reproduced except in full.
- The test report must not be used by the clients to claim product certification approval by any agency of the Government.

I **HEREBY CERTIFY THAT :**

The measurements shown in this test report were made in accordance with the procedures given in **ANSI C63.10 – 2013& FCC Part15.247** and the energy emitted by this equipment was **passed**.

Approved by:

Miro Chueh
EMC/RF Manager

Laboratory Accreditation:

CerpPASS Technology Corporation Test Laboratory

TAF LAB Code: 1439

CerpPASS Technology (SuZhou) Co., Ltd.

A2LA LAB Code: 4981.01



Table of Contents

1. Summary of Test Procedure and Test Results	5
1.1 Applicable Standards.....	5
2. Test Configuration of Equipment under Test	6
2.1 Feature of Equipment under Test.....	6
2.2 Carrier Frequency of Channels.....	6
2.3 Test Manner.....	6
2.4 Description of Test System.....	6
2.5 General Information of Test.....	7
2.6 Measurement Uncertainty.....	8
3. Test Equipment and Ancillaries Used for Tests	9
4. Antenna Requirements	10
4.1 Standard Applicable.....	10
4.2 Antenna Construction and Directional Gain.....	10
5. Test of Conducted Emission	11
5.1 Test Limit.....	11
5.2 Test Procedures.....	11
5.3 Typical Test Setup.....	11
5.4 Test Result and Data.....	12
6. Test of Radiated Emission	14
6.1 Test Limit.....	14
6.2 Test Procedures.....	14
6.3 Typical Test Setup.....	15
6.4 Test Result and Data (9KHz ~ 30MHz).....	16
6.5 Test Result and Data (30MHz ~ 1GHz).....	16
6.6 Test Result and Data (1GHz ~ 25GHz).....	17
6.7 Restricted Bands of Operation.....	23
6.8 Restrict Band Emission Measurement Data.....	24
7. Test of Spurious Emission (Conducted)	26
7.1 Test Limit.....	26
7.2 Test Procedure.....	26
7.3 Test Setup Layout.....	26
7.4 Test Result and Data.....	27
8. 6dB Bandwidth Measurement Data	29
8.1 Test Limit.....	29
8.2 Test Procedures.....	29
8.3 Test Setup Layout.....	29
8.4 Test Result and Data.....	30
9. Maximum Peak Output Power	32
9.1 Test Limit.....	32
9.2 Test Procedure.....	32
9.3 Test Setup Layout.....	32
9.4 Test Result and Data.....	33
10. Power Spectral Density	34
10.1 Test Limit.....	34



10.2	Test Procedure	34
10.3	Test Setup Layout.....	34
10.4	Test Result and Data	35



History of this test report

Original.

Additional attachment as following record:

Attachment No.	Issue Date	Description
TEFQ1907135	Aug. 03, 2019	Original

Report Type	Description
<input checked="" type="checkbox"/> Original report	NA
<input type="checkbox"/> Derivative Report	NA



1. Summary of Test Procedure and Test Results

1.1 Applicable Standards

FCC Rule	Description of Test	Result
FCC CFR Title 47 Part 15 Subpart C: Section 15.203/15.247 (b)	Antenna Requirement	Pass
FCC CFR Title 47 Part 15 Subpart C: Section 15.207	AC Power Line Conducted Emission	Pass
FCC CFR Title 47 Part 15 Subpart C: Section 15.205/15.209; Part2 section 2.1051, 2.1053, 2.1057	Spurious Emission(Radiated)	Pass
FCC CFR Title 47 Part 15 Subpart C: Section 15.247(d); Part2 section 2.1051 and 2.1057	Spurious Emission(Conducted)	Pass
FCC CFR Title 47 Part 15 Subpart C: Section 15.247(a)(2); Part2 section 2.1049	6dB Bandwidth	Pass
FCC CFR Title 47 Part 15 Subpart C: Section 15.247(b); Part2 section 2.1046	Maximum Peak Output Power	Pass
FCC CFR Title 47 Part 15 Subpart C: Section 15.247(e)	Power Spectral Density	Pass



2. Test Configuration of Equipment under Test

2.1 Feature of Equipment under Test

Product	WiFi/BT Module
Test Model	WF-R22C-USA1
Model Discrepancy	N/A
Frequency Range	2402~2480MHz
Number of Channels	40
Modulation	GFSK (Bluetooth low energy)
Data Rates	BT4.2: 1Mbps BT5.0: 2Mbps
EUT Power Rating:	Input: 3.3VDC

Note: for more details, please refer to the User's manual of the EUT.

2.2 Carrier Frequency of Channels

Channel	Frequency (MHz)	Channel	Frequency (MHz)	Channel	Frequency (MHz)
*00	2402	14	2430	28	2458
01	2404	15	2432	29	2460
02	2406	16	2434	30	2462
03	2408	17	2436	31	2464
04	2410	18	2438	32	2466
05	2412	*19	2440	33	2468
06	2414	20	2442	34	2470
07	2416	21	2444	35	2472
08	2418	22	2446	36	2474
09	2420	23	2448	37	2476
10	2422	24	2450	38	2478
11	2424	25	2452	*39	2480
12	2426	26	2454	--	--
13	2428	27	2456	--	--

Note: Channels remarked * are selected to perform test.

2.3 Test Manner

Test Manner	
a	During testing, the interface cables and equipment positions were varied according to 47 CFR, Part 2, Part 15
b	An executive program, " RTLBTAPP.exe ", under WIN 7 was executed to transmit and receive data via Bluetooth. Adjust the EUT at the test mode and the test channel. Then test. Test Mode:Mode 1: GFSK

2.4 Description of Test System

No	Device	Manufacturer	Model No.	Description
1	Notebook	SONY	PCG-71811P	R33021

Use Cable:

No.	Cable	Quantity	Description
A	DC Cable	1	1.7m Non Shielding



2.5 General Information of Test

<input type="checkbox"/>	Test Site	CerpPASS Technology Corporation Test Laboratory Address: No.10, Ln. 2, Lianfu St., Luzhu Dist., Taoyuan City 33848, Taiwan (R.O.C.) Tel:+886-3-3226-888 Fax:+886-3-3226-881 Address: No.68-1, Shihbachongsi, Shihding Township, New Taipei City 223, Taiwan, R.O.C. Tel: +886-2-2663-8582
	TAF	1439
	FCC	TW1079, TW1061
	IC	4934E-1, 4934E-2
	VCCI	T-2205 for Telecommunication Test C-4663 for Conducted emission test R-4399, R-4218 for Radiated emission test G-812, G-813 for radiated disturbance above 1GHz
<input checked="" type="checkbox"/>	Test Site	CerpPASS Technology (Suzhou) Co.,Ltd Address: No.66,Tangzhuang Road, Suzhou Industrial Park, Jiangsu 215006, China Tel: +86-512-6917-5888 Fax: +86-512-6917-5666
	CNAS	L5515
	FCC	CN1243
	A2LA	4981.01
	IC	7290A-1, 7290A-2
VCCI	T-1945 for Telecommunication Test C-2919 for Conducted emission test R-2670 for Radiated emission test G-227 for radiated disturbance above 1GHz	



2.6 Measurement Uncertainty

ISO/IEC 17025 requires that an estimate of the measurement uncertainties associated with the emissions test results be included in the report. The measurement uncertainties given below are based on a 95% confidence level (based on a coverage factor (k=2)).

RF Conducted Measurement

Test Item		Uncertainty	Limit
Radio Frequency		$\pm 8.7 \times 10^{-7}$	$\pm 1 \times 10^{-5}$
RF output power, conducted		$\pm 0.63 \text{dB}$	$\pm 1.5 \text{dB}$
Power density, conducted		$\pm 1.21 \text{dB}$	$\pm 3 \text{dB}$
Unwanted emissions, conducted	30-1000MHz	$\pm 0.51 \text{dB}$	$\pm 3 \text{dB}$
	1-25GHz	$\pm 0.67 \text{dB}$	$\pm 3 \text{dB}$
All emissions, radiated	30-1000MHz	$\pm 2.28 \text{dB}$	$\pm 6 \text{dB}$
	1-25GHz	$\pm 2.59 \text{dB}$	$\pm 6 \text{dB}$
Temperature		$\pm 0.8^\circ\text{C}$	$\pm 1^\circ\text{C}$
Humidity		$\pm 3\%$	$\pm 5\%$
DC and low frequency voltages		$\pm 3\%$	$\pm 3\%$



3. Test Equipment and Ancillaries Used for Tests

Instrument/Ancillary	Manufacturer	Model No.	Serial No.	Calibration Date	Valid Date.
EMI Receiver	R&S	ESCI3	100563	2019.06.21	2020.06.20
LISN	Schwarzbeck	NSLK 8127	8127-920	2018.09.25	2019.09.24
Pulse Limiter	R&S	ESH3-Z2	100529	2019.03.11	2020.03.10
Software	Farad	Ez-EMC	ver.ct3a1	N/A	N/A

Instrument/Ancillary	Manufacturer	Model No.	Serial No.	Calibration Date	Valid Date.
Bilog Antenna	Sunol	JB1	A072414-2 -2	2019.07.13	2020.07.13
EMI Receiver	R&S	ESCI3	101183	2019.06.28	2020.06.27
EMI Receiver	R&S	ESCI7	100968	2018.07.30	2019.07.29
Preamplifier	EM Electronics corp.	EM330	60618	2019.03.11	2020.03.10
Horn Antenna	Schwarzbeck	BBHA9120 D	9120D-619	2019.07.13	2020.07.13
Horn Antenna	Schwarzbeck	BBHA9170	9170-348	2019.06.23	2020.06.22
Spectrum Analyzer	R&S	FSP40	100324	2019.07.13	2020.07.12
Preamplifier	EMCI	EMCI 030-00-3230	SN016723	2019.03.11	2020.03.10
Preamplifier	EM Electronics corp.	EM01G18G	SN060714	2019.03.23	2020.03.22
Spectrum Analyzer	KEYSIGHT	N9010A	MY53400169	2018.08.25	2019.08.24
Software	E3	AUDIX	Version: 8.14.806b	N/A	N/A



4. Antenna Requirements

4.1 Standard Applicable

For intentional device, according to FCC 47 CFR Section 15.203, an intentional radiator shall be designed to ensure that no antenna other than that furnished by the responsible party shall be used with the device.

And according to FCC 47 CFR Section 15.247 (b), if transmitting antennas of directional gain greater than 6dBi are used, the power shall be reduced by the amount in dB that the directional gain of the antenna exceeds 6dBi.

4.2 Antenna Construction and Directional Gain

Antenna	Peak Gain
Dipole Antenna	3.18dBi



5. Test of Conducted Emission

5.1 Test Limit

Conducted Emissions were measured from 150 kHz to 30 MHz with a bandwidth of 9 KHz on the 120 VAC power and return leads of the EUT according to the methods defined in ANSI C63.10-2013. The EUT was placed on a nonmetallic stand in a shielded room 0.8 meters above the ground plane as shown in section 6.2.2. The interface cables and equipment positioning were varied within limits of reasonable applications to determine the position produced maximum conducted emissions.

Frequency (MHz)	Quasi Peak (dB μ V)	Average (dB μ V)
0.15 – 0.5	66-56*	56-46*
0.5 – 5.0	56	46
5.0 – 30.0	60	50

*Decreases with the logarithm of the frequency.

5.2 Test Procedures

The EUT was setup according to ANSI C63.10, 2013 and tested according to DTS test procedure of Oct 2014 KDB558074 for compliance to FCC 47CFR 15.247 requirements. The EUT was placed on a platform of nominal size, 1 m by 1.5 m, raised 80 cm above the conducting ground plane. The vertical conducting plane was located 40 cm to the rear of the EUT. All other surfaces of EUT were at least 80 cm from any other grounded conducting surface. The EUT and simulators are connected to the main power through a line impedance stabilization network (LISN). The LISN provides a 50 ohm /50uH coupling impedance for the measuring equipment. The peripheral devices are also connected to the main power through a LISN. (Please refer to the block diagram of the test setup and photographs) Each current-carrying conductor of the EUT power cord, except the ground (safety) conductor, was individually connected through a LISN to the input power source. The excess length of the power cord between the EUT and the LISN receptacle were folded back and forth at the center of the lead to form a bundle not exceeding 40 cm in length. Conducted emissions were investigated over the frequency range from 0.15MHz to 30MHz using a receiver bandwidth of 9kHz.

5.3 Typical Test Setup

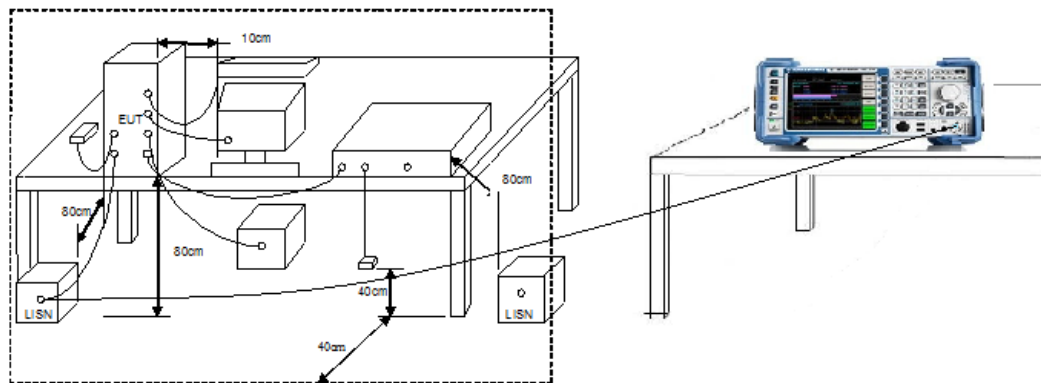



5.4 Test Result and Data

Test Mode :	Normal Link		
AC Power :	AC 120V/60Hz	Phase:	LINE
Temperature :	26°C	Humidity:	60%
Pressure(mbar) :	1002	Date:	2019-07-22

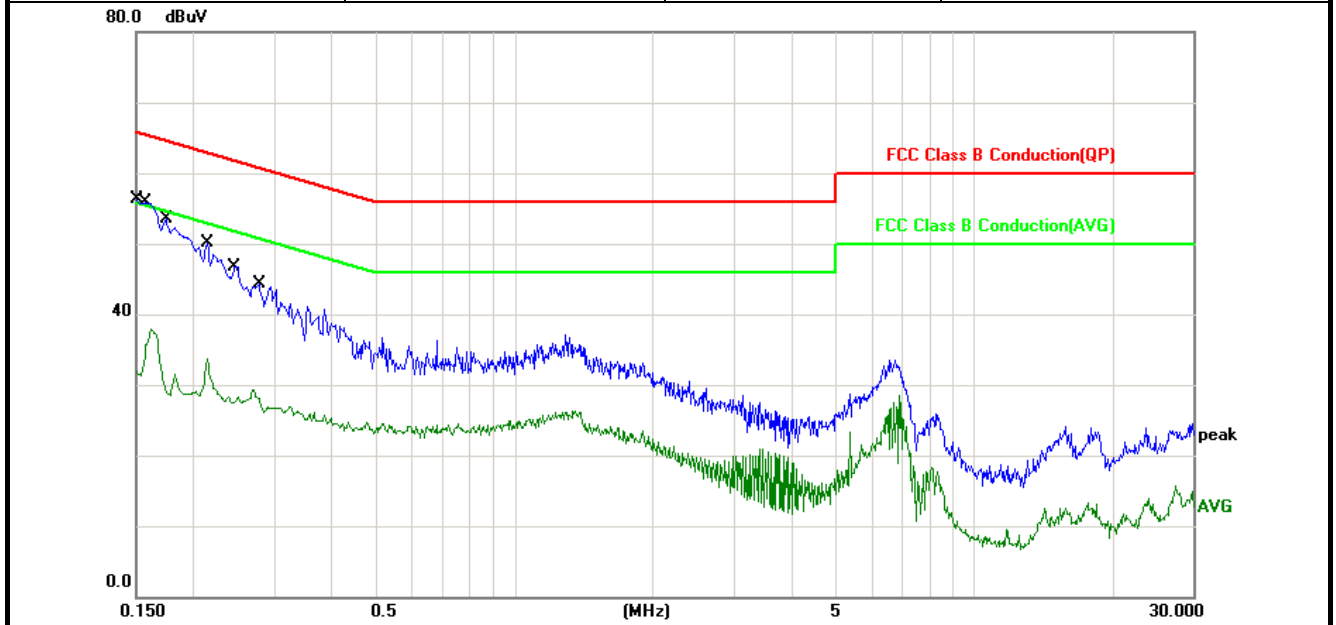

No.	Frequency (MHz)	Factor (dB)	Reading (dBuV)	Level (dBuV)	Limit (dBuV)	Margin (dB)	Detector
1	0.1500	10.06	39.37	49.43	65.99	-16.56	QP
2	0.1500	10.06	20.73	30.79	55.99	-25.20	AVG
3	0.1580	10.06	38.45	48.51	65.56	-17.05	QP
4	0.1580	10.06	24.43	34.49	55.56	-21.07	AVG
5	0.1740	10.06	36.37	46.43	64.76	-18.33	QP
6	0.1740	10.06	19.99	30.05	54.76	-24.71	AVG
7	0.2140	10.05	32.31	42.36	63.04	-20.68	QP
8	0.2140	10.05	21.26	31.31	53.04	-21.73	AVG
9	0.2460	10.03	29.15	39.18	61.89	-22.71	QP
10	0.2460	10.03	17.67	27.70	51.89	-24.19	AVG
11	0.2779	10.02	27.02	37.04	60.88	-23.84	QP
12	0.2779	10.02	17.22	27.24	50.88	-23.64	AVG

Note: Measurement Level = Reading Level + Correct Factor



Test Mode :	Normal Link		
AC Power :	AC 120V/60Hz	Phase:	NEUTRAL
Temperature :	26°C	Humidity:	60%
Pressure(mbar) :	1002	Date:	2019-07-22

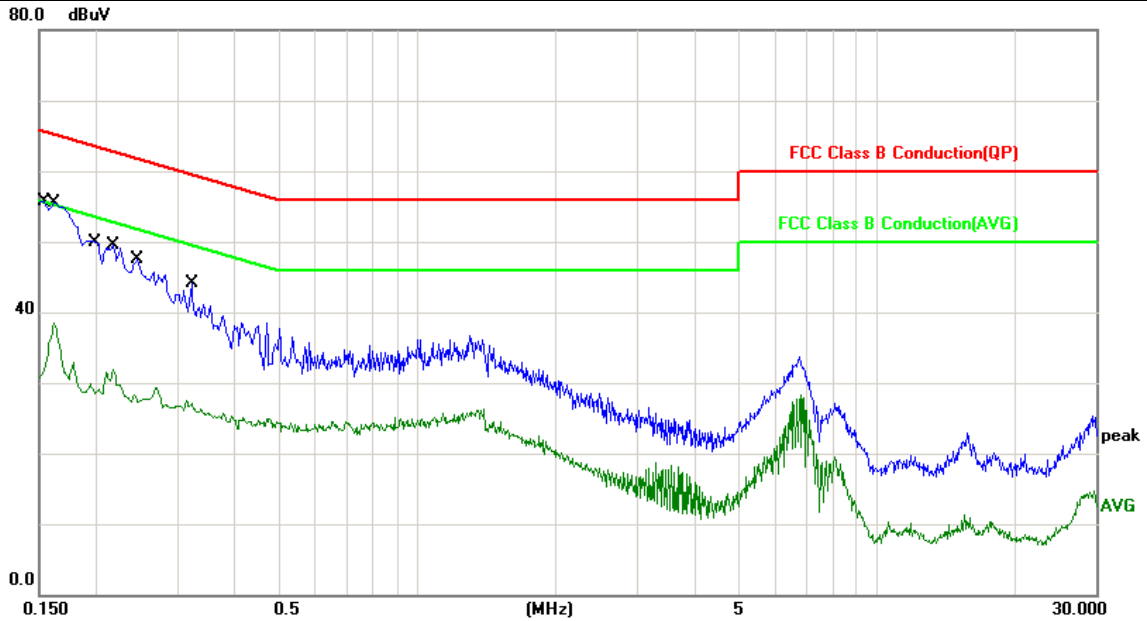

No.	Frequency (MHz)	Factor (dB)	Reading (dBuV)	Level (dBuV)	Limit (dBuV)	Margin (dB)	Detector
1	0.1539	10.06	39.52	49.58	65.78	-16.20	QP
2	0.1539	10.06	21.22	31.28	55.78	-24.50	AVG
3	0.1620	10.06	39.00	49.06	65.36	-16.30	QP
4	0.1620	10.06	26.93	36.99	55.36	-18.37	AVG
5	0.2007	10.06	33.10	43.16	63.58	-20.42	QP
6	0.2007	10.06	18.82	28.88	53.58	-24.70	AVG
7	0.2180	10.05	32.31	42.36	62.89	-20.53	QP
8	0.2180	10.05	21.76	31.81	52.89	-21.08	AVG
9	0.2460	10.03	28.95	38.98	61.89	-22.91	QP
10	0.2460	10.03	17.68	27.71	51.89	-24.18	AVG
11	0.3220	9.99	24.44	34.43	59.65	-25.22	QP
12	0.3220	9.99	16.59	26.58	49.65	-23.07	AVG



6. Test of Radiated Emission

6.1 Test Limit

In any 100kHz bandwidth outside the frequency band in which the spread spectrum or digitally modulated intentional radiator is operating, the radio frequency power that is produced by the intentional radiator shall be at least 20dB below that in the 100kHz bandwidth within the band that contains the highest level of the desired power, based on either an RF conducted or a radiated measurement. If the transmitter measurement is based on the maximum conducted output power, the attenuation required under this paragraph shall be 30dB instead of 20dB. In addition, radiated emissions which fall in section 15.205(a) the restricted bands must also comply with the radiated emission limit specified in section 15.209(a).

Frequency (MHz)	Field Strength (microvolt/meter)	Measurement Distance (meters)
0.009 ~ 0.490	2400/F(kHz)	300
0.490 ~ 1.705	24000/F(kHz)	30
1.705 ~ 30.0	30	30
30 ~ 88	100	3
88 ~ 216	150	3
216 ~ 960	200	3
Above 960	500	3

6.2 Test Procedures

- The EUT was placed on a rotatable table top 0.8 meter above ground.
- The EUT was set 3 meters from the interference receiving antenna which was mounted on the top of a variable height antenna tower.
- The table was rotated 360 degrees to determine the position of the highest radiation.
- The antenna is a broadband antenna and its height is varied between one meter and four meters above ground to find the maximum value of the field strength both horizontal polarization and vertical polarization of the antenna are set to make the measurement.
- For each suspected emission the EUT was arranged to its worst case and then tune the antenna tower (from 1 M to 4 M) and turn table (from 0 degree to 360 degrees) to find the maximum reading.
- Set the test-receiver system to Peak or CISPR quasi-peak Detect Function and specified bandwidth with Maximum Hold Mode.
- If the emission level of the EUT in peak mode was 3 dB lower than the limit specified, then testing will be stopped and peak values of EUT will be reported, otherwise, the emissions which do not have 3 dB margin will be repeated one by one using the quasi-peak method and reported.
- For testing above 1GHz, the emission level of the EUT in peak mode was 20dB lower than average limit (that means the emission level in peak mode also complies with the limit in average mode), then testing will be stopped and peak values of EUT will be reported, otherwise, the emissions will be measured in average mode again and reported.
- "Cone of radiation" has been considered to be 3dB bandwidth of the measurement antenna.



6.3 Typical Test Setup

Below 30MHz Test Setup

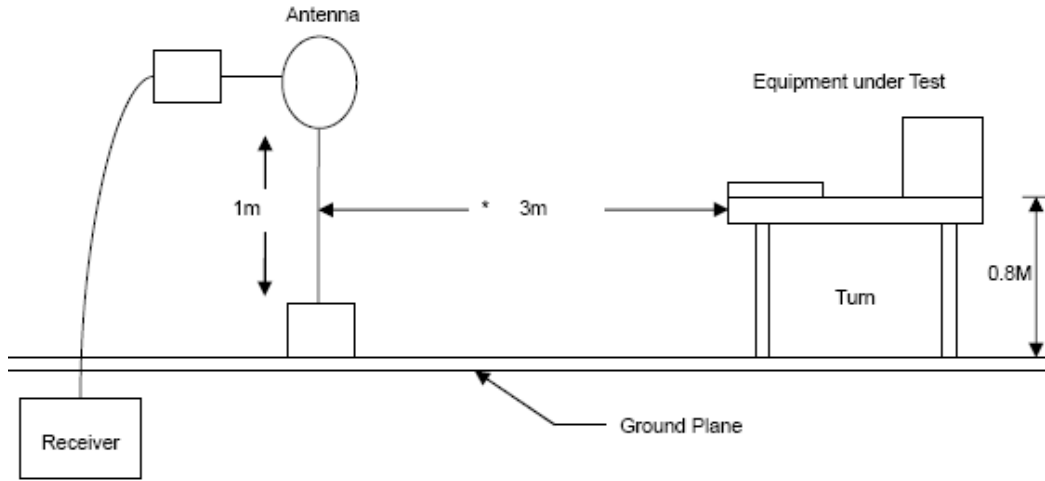

30M - 1GHz Test Setup

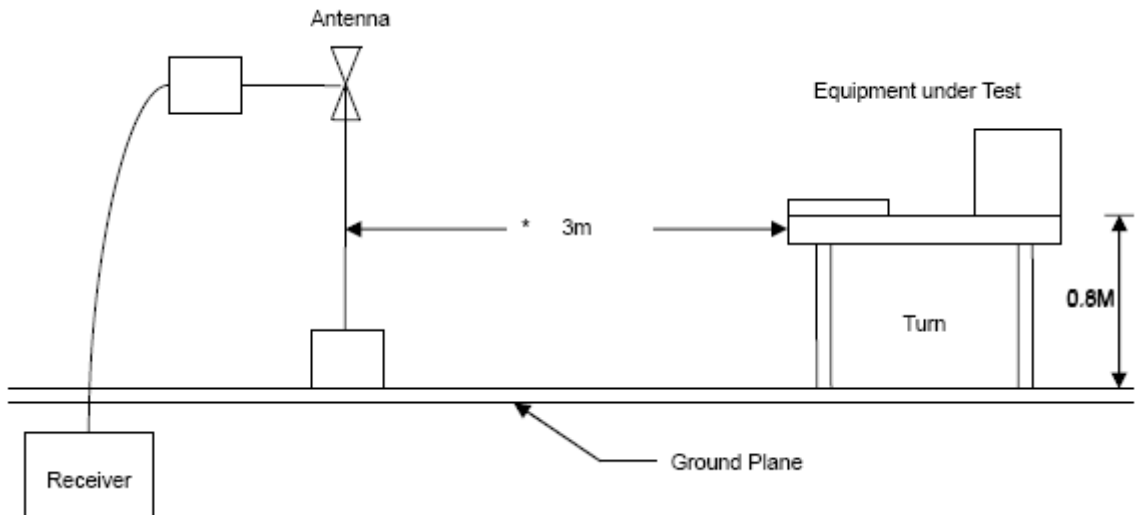

Above 1GHz Test Setup

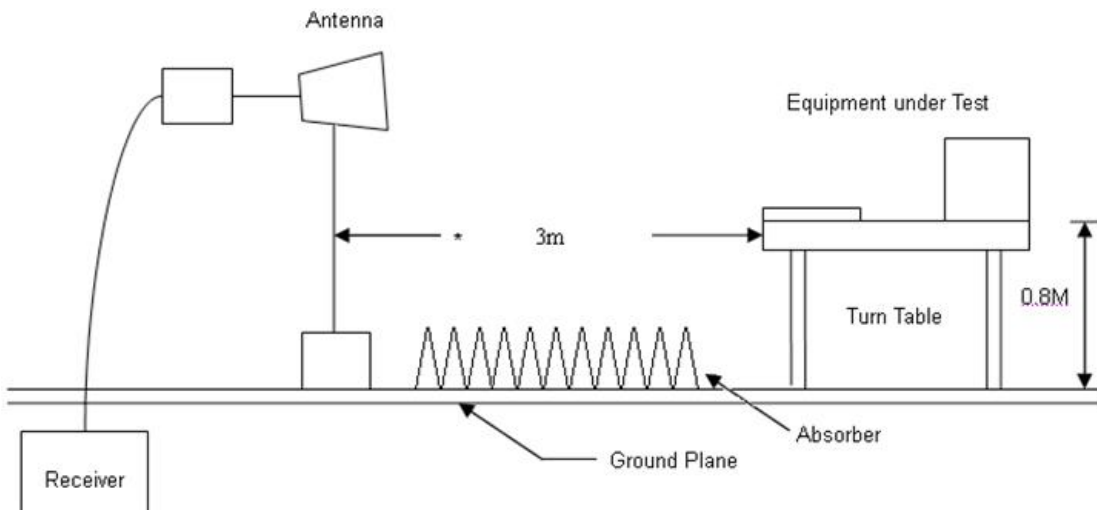

**6.4 Test Result and Data (9KHz ~ 30MHz)**

The 9kHz-30MHz spurious emission is under limit 20dB more.

6.5 Test Result and Data (30MHz ~ 1GHz)

Power	: DC 3.3V	Temperature	: 24 °C
Test Mode	: Normal Link	Humidity	: 54 %
Test date	: Jul. 14, 2019	Atmospheric Pressure	: 1010 hpa

Frequency (MHz)	Correct Factor (dB)	Reading level (dBuV)	Measure Level (dBuV/m)	Limit 3m (dBuV/m)	Safe Margin (dB)	Detector mode (PK/QP)	AntPol. H/V
119.2400	-10.36	46.27	35.91	43.50	-7.59	peak	H
208.4800	-9.62	45.89	36.27	43.50	-7.23	QP	H
239.5200	-7.03	47.65	40.62	46.00	-5.38	QP	H
275.4100	-6.75	46.32	39.57	46.00	-6.43	QP	H
482.0200	-2.03	41.04	39.01	46.00	-6.99	peak	H
762.3500	0.96	33.13	34.09	46.00	-11.91	peak	H
32.9099	-7.38	40.69	33.31	40.00	-6.69	peak	V
206.5399	-8.63	44.58	35.95	43.50	-7.55	peak	V
238.5500	-8.81	46.39	37.58	46.00	-8.42	peak	V
276.3798	-10.63	46.33	35.70	46.00	-10.30	peak	V
481.0500	-1.97	36.54	34.57	46.00	-11.43	peak	V
689.6000	-2.25	37.57	35.32	46.00	-10.68	peak	V

Note: Level = Reading + Factor

Margin = Level – Limit

Factor= Antenna Factor + Cable Loss - Amplifier Factor

**6.6 Test Result and Data (1GHz ~ 25GHz)****Bluetooth (LE), 1Mbps**

Power	: DC 3.3V	Temperature	: 24 °C
Test Mode1	2402MHz	Humidity	: 54 %
Test date	: Jul. 14, 2019	Atmospheric Pressure	: 1010 hpa

Frequency (MHz)	Correct Factor (dB)	Reading level (dBuV)	Measure Level (dBuV/m)	Limit 3m (dBuV/m)	Safe Margin (dB)	Detector mode (PK/AVG)	AntPol. H/V
3266.667	-4.83	44.97	40.14	74.00	-33.86	peak	H
4230.000	-0.72	42.28	41.56	74.00	-32.44	peak	H
4804.000	1.23	40.03	41.26	74.00	-32.74	peak	H
5788.333	2.74	38.19	40.93	74.00	-33.07	peak	H
6553.333	3.63	38.51	42.14	74.00	-31.86	peak	H
7206.000	5.88	35.89	41.77	74.00	-32.23	peak	H
3210.000	-5.13	44.74	39.61	74.00	-34.39	peak	V
3946.667	-2.07	40.87	38.80	74.00	-35.20	peak	V
4804.000	1.23	40.14	41.37	74.00	-32.63	peak	V
5533.333	2.10	38.22	40.32	74.00	-33.68	peak	V
6525.000	3.54	38.43	41.97	74.00	-32.03	peak	V
7206.000	5.88	37.12	43.00	74.00	-31.00	peak	V

Note: Level = Reading + Factor

Margin = Level – Limit

Factor= Antenna Factor + Cable Loss - Amplifier Factor



Power	: DC 3.3V	Temperature	: 24 °C
Test Mode1	2440MHz	Humidity	: 54 %
Test date	: Jul. 14, 2019	Atmospheric Pressure	: 1010 hpa

Frequency (MHz)	Correct Factor (dB)	Reading level (dBuV)	Measure Level (dBuV/m)	Limit 3m (dBuV/m)	Safe Margin (dB)	Detector mode (PK/AVG)	AntPol. H/V
3975.000	-1.98	41.47	39.49	74.00	-34.51	peak	H
4400.000	0.15	39.69	39.84	74.00	-34.16	peak	H
4880.000	1.37	40.03	41.40	74.00	-32.60	peak	H
6156.667	3.32	37.97	41.29	74.00	-32.71	peak	H
6780.000	4.37	36.87	41.24	74.00	-32.76	peak	H
7320.000	6.33	36.25	42.58	74.00	-31.42	peak	H
4003.333	-1.87	40.96	39.09	74.00	-34.91	peak	V
4428.333	0.29	38.85	39.14	74.00	-34.86	peak	V
4880.000	1.37	39.22	40.59	74.00	-33.41	peak	V
5731.667	2.59	37.30	39.89	74.00	-34.11	peak	V
6241.667	3.36	37.95	41.31	74.00	-32.69	peak	V
7320.000	6.33	35.61	41.94	74.00	-32.06	peak	V

Note: Level = Reading + Factor

Margin = Level – Limit

Factor= Antenna Factor + Cable Loss - Amplifier Factor



Power	: DC 3.3V	Temperature	: 24 °C
Test Mode1	2480MHz	Humidity	: 54 %
Test date	: Jul. 14, 2019	Atmospheric Pressure	: 1010 hpa

Frequency (MHz)	Correct Factor (dB)	Reading level (dBuV)	Measure Level (dBuV/m)	Limit 3m (dBuV/m)	Safe Margin (dB)	Detector mode (PK/AVG)	AntPol. H/V
3946.667	-2.07	41.14	39.07	74.00	-34.93	peak	H
4428.333	0.29	39.85	40.14	74.00	-33.86	peak	H
4960.000	1.52	38.37	39.89	74.00	-34.11	peak	H
6128.333	3.31	38.66	41.97	74.00	-32.03	peak	H
6921.667	4.83	36.35	41.18	74.00	-32.82	peak	H
7440.000	6.80	35.69	42.49	74.00	-31.51	peak	H
4003.333	-1.87	40.96	39.09	74.00	-34.91	peak	V
4541.667	0.74	40.58	41.32	74.00	-32.68	peak	V
4960.000	1.52	39.63	41.15	74.00	-32.85	peak	V
6100.000	3.30	37.08	40.38	74.00	-33.62	peak	V
6695.000	4.09	36.73	40.82	74.00	-33.18	peak	V
7440.000	6.80	35.91	42.71	74.00	-31.29	peak	V

Note: Level = Reading + Factor
Margin = Level – Limit
Factor= Antenna Factor + Cable Loss - Amplifier Factor



Bluetooth (LE), 2Mbps

Power	: DC 3.3V	Temperature	: 24 °C
Test Mode1	2402MHz	Humidity	: 54 %
Test date	: Aug. 03, 2019	Atmospheric Pressure	: 1010 hpa

Frequency (MHz)	Correct Factor (dB)	Reading level (dBuV)	Measure Level (dBuV/m)	Limit 3m (dBuV/m)	Safe Margin (dB)	Detector mode (PK/AVG)	AntPol. H/V
3861.667	-2.36	41.87	39.51	74.00	-34.49	peak	H
4804.000	1.23	40.12	41.35	74.00	-32.65	peak	H
5561.667	2.17	38.31	40.48	74.00	-33.52	peak	H
6015.000	3.27	37.62	40.89	74.00	-33.11	peak	H
6723.333	4.18	38.40	42.58	74.00	-31.42	peak	H
7206.000	5.88	36.17	42.05	74.00	-31.95	peak	H
3493.333	-3.64	42.79	39.15	74.00	-34.85	peak	V
3918.333	-2.17	41.68	39.51	74.00	-34.49	peak	V
4804.000	1.23	40.12	41.35	74.00	-32.65	peak	V
5448.333	1.98	38.24	40.22	74.00	-33.78	peak	V
6156.667	3.32	36.90	40.22	74.00	-33.78	peak	V
7206.000	5.88	37.18	43.06	74.00	-30.94	peak	V

Note: Level = Reading + Factor
Margin = Level – Limit
Factor= Antenna Factor + Cable Loss - Amplifier Factor



Power	: DC 3.3V	Temperature	: 24 °C
Test Mode1	2440MHz	Humidity	: 54 %
Test date	: Aug. 03, 2019	Atmospheric Pressure	: 1010 hpa

Frequency (MHz)	Correct Factor (dB)	Reading level (dBuV)	Measure Level (dBuV/m)	Limit 3m (dBuV/m)	Safe Margin (dB)	Detector mode (PK/AVG)	AntPol. H/V
3748.333	-2.75	41.75	39.00	74.00	-35.00	peak	H
4116.667	-1.29	39.76	38.47	74.00	-35.53	peak	H
4880.000	1.37	39.95	41.32	74.00	-32.68	peak	H
5930.000	3.09	37.29	40.38	74.00	-33.62	peak	H
6666.667	4.00	37.10	41.10	74.00	-32.90	peak	H
7320.000	6.33	36.24	42.57	74.00	-31.43	peak	H
3578.333	-3.33	42.51	39.18	74.00	-34.82	peak	V
3946.667	-2.07	40.37	38.30	74.00	-35.70	peak	V
4880.000	1.37	39.54	40.91	74.00	-33.09	peak	V
6043.333	3.28	36.76	40.04	74.00	-33.96	peak	V
6270.000	3.37	37.07	40.44	74.00	-33.56	peak	V
7320.000	6.33	35.92	42.25	74.00	-31.75	peak	V

Note: Level = Reading + Factor

Margin = Level – Limit

Factor= Antenna Factor + Cable Loss - Amplifier Factor



Power	: DC 3.3V	Temperature	: 24 °C
Test Mode1	2480MHz	Humidity	: 54 %
Test date	: Aug. 03, 2019	Atmospheric Pressure	: 1010 hpa

Frequency (MHz)	Correct Factor (dB)	Reading level (dBuV)	Measure Level (dBuV/m)	Limit 3m (dBuV/m)	Safe Margin (dB)	Detector mode (PK/AVG)	AntPol. H/V
3323.333	-4.53	41.58	37.05	74.00	-36.95	peak	H
3890.000	-2.27	40.03	37.76	74.00	-36.24	peak	H
4960.000	1.52	38.74	40.26	74.00	-33.74	peak	H
5930.000	3.09	37.29	40.38	74.00	-33.62	peak	H
6355.000	3.40	37.47	40.87	74.00	-33.13	peak	H
7440.000	6.80	35.87	42.67	74.00	-31.33	peak	H
3181.667	-5.27	45.54	40.27	74.00	-33.73	peak	V
4088.333	-1.44	40.59	39.15	74.00	-34.85	peak	V
4960.000	1.52	40.21	41.73	74.00	-32.27	peak	V
6043.333	3.28	36.26	39.54	74.00	-34.46	peak	V
6468.333	3.45	36.43	39.88	74.00	-34.12	peak	V
7440.000	6.80	36.10	42.90	74.00	-31.10	peak	V

Note: Level = Reading + Factor

Margin = Level – Limit

Factor= Antenna Factor + Cable Loss - Amplifier Factor



6.7 Restricted Bands of Operation

Only spurious emissions are permitted in any of the frequency bands listed below:

MHz	MHz	MHz	GHz
0.09000 – 0.11000	16.42000 – 16.42300	399.9 – 410.0	4.500 – 5.250
0.49500 – 0.505**	16.69475 – 16.69525	608.0 – 614.0	5.350 – 5.460
2.17350 – 2.19050	16.80425 – 16.80475	960.0 – 1240.0	7.250 – 7.750
4.12500 – 4.12800	25.50000 – 25.67000	1300.0 – 1427.0	8.025 – 8.500
4.17725 – 4.17775	37.50000 – 38.25000	1435.0 – 1626.5	9.000 – 9.200
4.20725 – 4.20775	73.00000 – 74.60000	1645.5 – 1646.5	9.300 – 9.500
6.21500 – 6.21800	74.80000 – 75.20000	1660.0 – 1710.0	10.600 – 12.700
6.26775 – 6.26825	108.00000 – 121.94000	1718.8 – 1722.2	13.250 – 13.400
6.31175 – 6.31225	123.00000 – 138.00000	2200.0 – 2300.0	14.470 – 14.500
8.29100 – 8.29400	149.90000 – 150.05000	2310.0 – 2390.0	15.350 – 16.200
8.36200 – 8.36600	156.52475 – 156.52525	2483.5 – 2500.0	17.700 – 21.400
8.37625 – 8.38675	156.70000 – 156.90000	2655.0 – 2900.0	22.010 – 23.120
8.41425 – 8.41475	162.01250 – 167.17000	3260.0 – 3267.0	23.600 – 24.000
12.29000 – 12.29300	167.72000 – 173.20000	3332.0 – 3339.0	31.200 – 31.800
12.51975 – 12.52025	240.00000 – 285.00000	3345.8 – 3358.0	36.430 – 36.500
12.57675 – 12.57725	322.00000 – 335.40000	3600.0 – 4400.0	Above 38.6
13.36000 – 13.41000			

** : Until February 1, 1999, this restricted band shall be 0.490-0.510 MHz

**6.8 Restrict Band Emission Measurement Data**

Test Date : Jul. 14, 2019
 Temperature : 24 °C
 Humidity : 52 %
 Atmospheric Pressure : 1023 hPa

Modulation Standard:GFSK Bluetooth (LE), 1Mbps

Channel 00		Fundamental Frequency: 2402 MHz					
Frequency (MHz)	Factor (dB/m)	Reading (dBuV)	Level (dBuV/m)	Limit (dBuV/m)	Margin (dB)	Det.	Ant-Pol H/V
2390.000	-10.05	47.00	36.95	74.00	-37.05	peak	H
2390.000	-10.05	35.90	25.85	54.00	-28.15	AVG	H
2390.000	-10.05	47.56	37.51	74.00	-36.49	peak	V
2390.000	-10.05	36.84	26.79	54.00	-27.21	AVG	V
Channel 39		Fundamental Frequency: 2480 MHz					
2483.500	-9.65	47.64	37.99	74.00	-36.01	peak	H
2483.500	-9.65	35.47	25.82	54.00	-28.18	AVG	H
2483.500	-9.65	45.90	36.25	74.00	-37.75	peak	V
2483.500	-9.65	35.54	25.89	54.00	-28.11	AVG	V

Notes:

1. Result = Meter Reading + Factor
2. Factor = Antenna Factor + Cable Loss – Amplifier
3. The resolution bandwidth of test receiver/spectrum analyzer is 1MHz and video bandwidth is 3 MHz (detector peak mode) for Peak detection at frequency above 1GHz.
4. The resolution bandwidth of test receiver/spectrum analyzer is 1MHz and video bandwidth is 3 MHz (detector sample mode) for Average detection at frequency above 1GHz



Test Date : Aug. 03, 2019
 Temperature : 24 °C
 Humidity : 52 %
 Atmospheric Pressure : 1023 hPa

Modulation Standard:GFSK Bluetooth (LE), 2Mbps

Channel 00				Fundamental Frequency: 2402 MHz			
Frequency (MHz)	Factor (dB/m)	Reading (dBuV)	Level (dBuV/m)	Limit (dBuV/m)	Margin (dB)	Det.	Ant-Pol H/V
2390.000	-10.05	47.08	37.03	74.00	-36.97	peak	H
2390.000	-10.05	35.69	25.64	54.00	-28.36	AVG	H
2390.000	-10.05	47.47	37.42	74.00	-36.58	peak	V
2390.000	-10.05	35.94	25.89	54.00	-28.11	AVG	V
Channel 39				Fundamental Frequency: 2480 MHz			
2483.500	-9.65	49.77	40.12	74.00	-33.88	peak	H
2483.500	-9.65	35.52	25.87	54.00	-28.13	AVG	H
2483.500	-9.65	50.90	41.25	74.00	-32.75	peak	V
2483.500	-9.65	35.79	26.14	54.00	-27.86	AVG	V

Notes:

1. Result = Meter Reading + Factor
2. Factor = Antenna Factor + Cable Loss – Amplifier
3. The resolution bandwidth of test receiver/spectrum analyzer is 1MHz and video bandwidth is 3 MHz (detector peak mode) for Peak detection at frequency above 1GHz.
4. The resolution bandwidth of test receiver/spectrum analyzer is 1MHz and video bandwidth is 3 MHz (detector sample mode) for Average detection at frequency above 1GHz



7. Test of Spurious Emission (Conducted)

7.1 Test Limit

Below 30dB of the highest emission level of operating band (In 100 kHz Resolution Bandwidth)

7.2 Test Procedure

KDB 558074 D01 DTS Meas Guidance v03r05

1. Reference level measurement

- (a) Set instrument center frequency to DTS channel center frequency
- (b) Set the span to ≥ 1.5 times the DTS bandwidth
- (c) Set the RBW = 100 kHz
- (d) Set the VBW $\geq 3 \times$ RBW
- (e) Detector = peak
- (f) Sweep time = auto couple
- (g) Trace mode = max hold
- (h) Allow trace to fully stabilize

2. Emission level measurement

- (a) Set the center frequency and span to encompass frequency range to be measured
- (b) RBW = 100kHz
- (c) VBW = 300kHz
- (d) Detector = Peak
- (e) Trace mode = max hold
- (f) Sweep time = auto couple
- (g) The trace was allowed to stabilize

7.3 Test Setup Layout

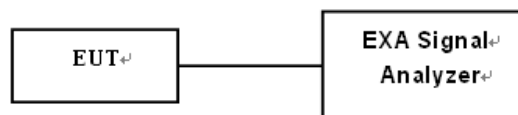



7.4 Test Result and Data
Bluetooth (LE), 1Mbps

Modulation Standard	Channel	Frequency (MHz)	Test Result
GFSK	0	2402	PASS
	19	2440	PASS
	39	2480	PASS

Modulation Type: GFSK
Channel 00

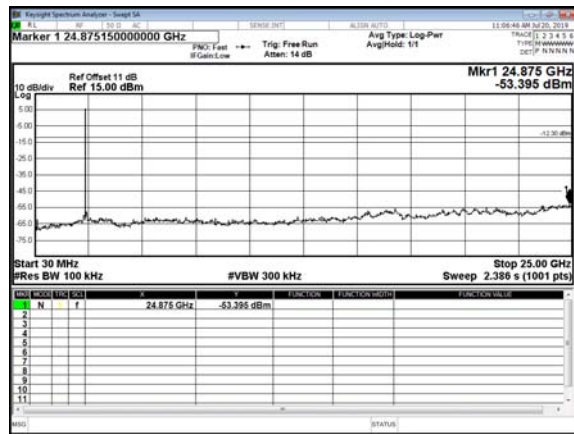
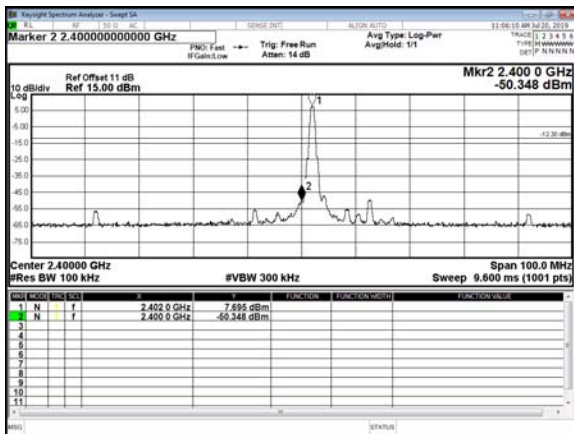

CH19

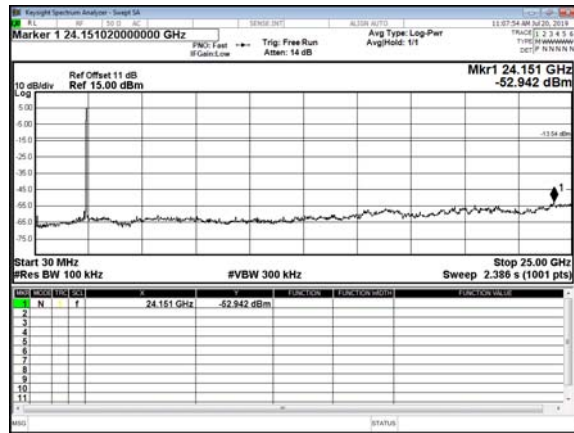
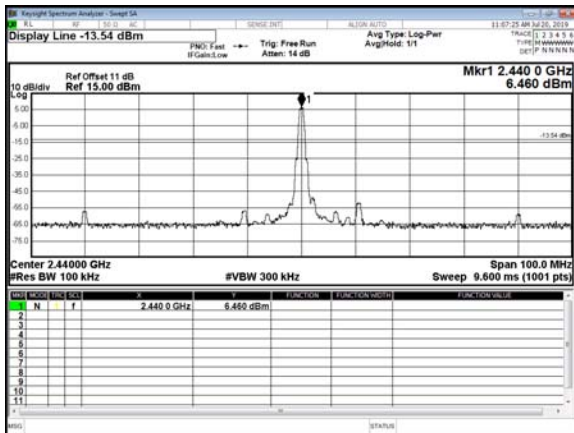

CH39

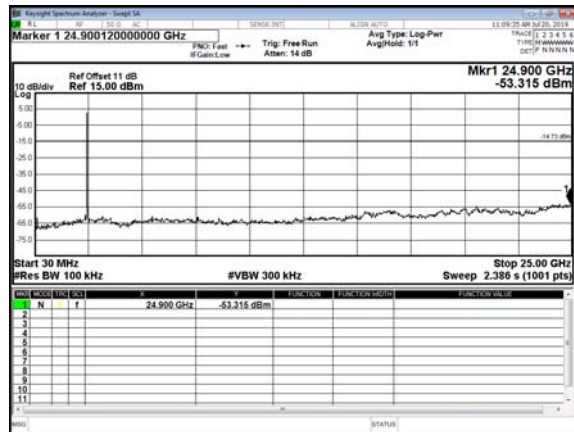
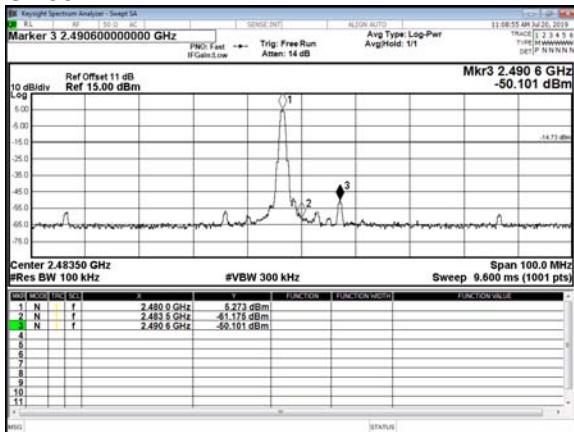



Bluetooth (LE),2Mbps

Modulation Standard	Channel	Frequency (MHz)	Test Result
GFSK	0	2402	PASS
	19	2440	PASS
	39	2480	PASS

Modulation Type: GFSK
Channel 00

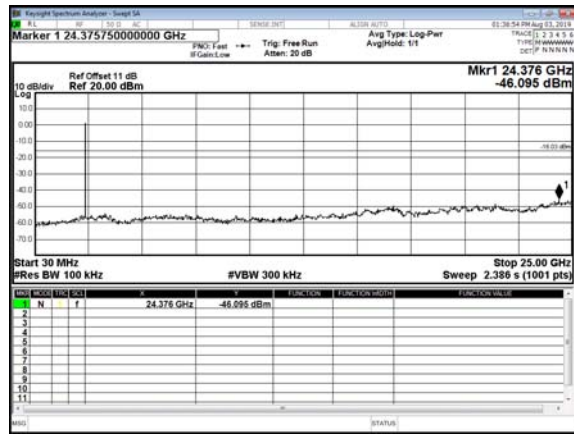
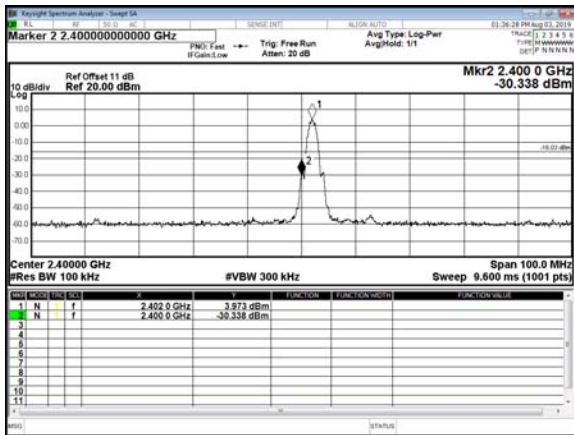

CH19

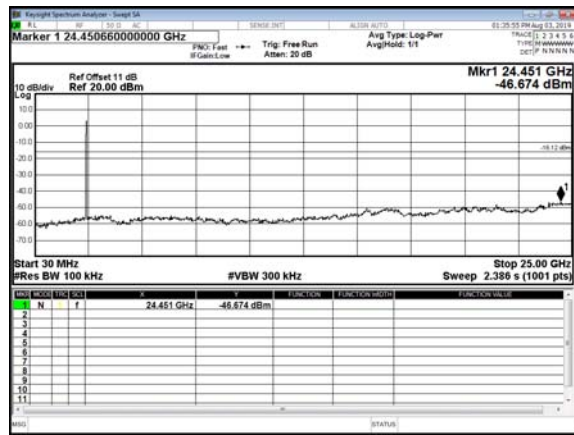
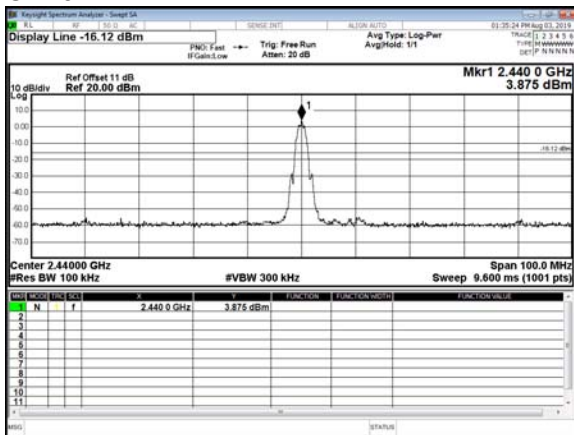

CH39

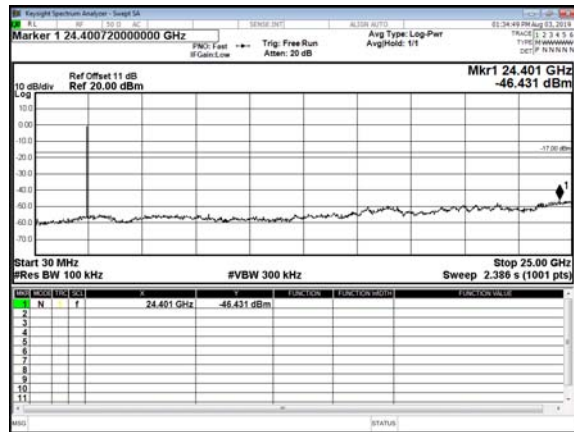
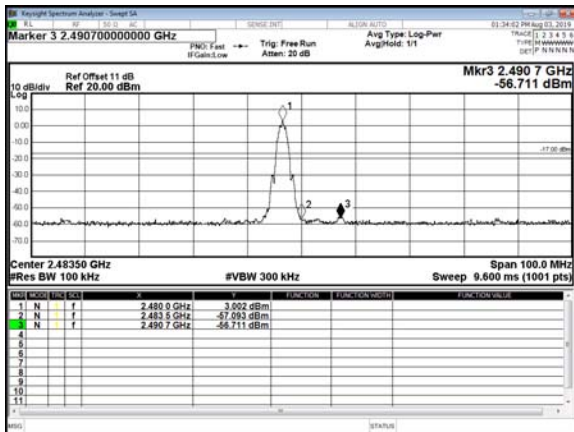



8. 6dB Bandwidth Measurement Data

8.1 Test Limit

The minimum of 6dB Bandwidth Measurement is 0.5 MHz.

8.2 Test Procedures

- a. The transmitter output was connected to the spectrum analyzer.
- b. Set RBW of spectrum analyzer to 100 KHz and VBW to 300 KHz.
- c. Set spectrum analyzer X dB to 6 dB.
- d. Set spectrum analyzer peak detector with maximum hold.

8.3 Test Setup Layout

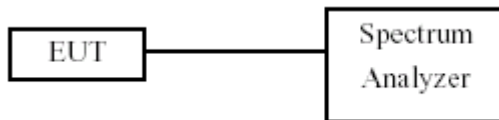



8.4 Test Result and Data

Bluetooth (LE), 1Mbps

Test Date: Jul. 20, 2019

Temperature: 23 °C

Atmospheric pressure: 1087 hPa

Humidity: 54 %

Modulation Type	Channel	Frequency (MHz)	6dB Bandwidth (KHz)
GFSK	00	2402	668.20
	19	2440	667.70
	39	2480	667.90

Modulation Standard: GFSK (1Mbps)
Channel: 00

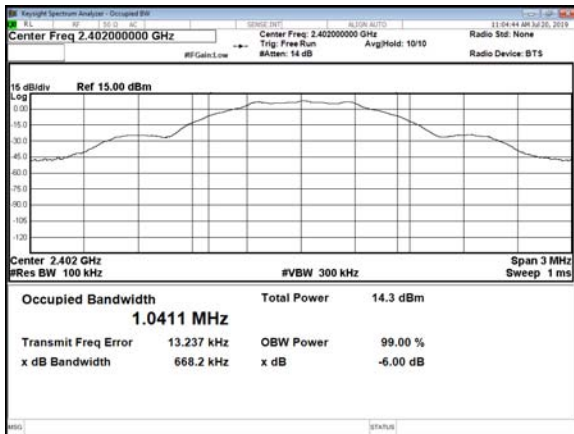

Modulation Standard: GFSK (1Mbps)
Channel: 19

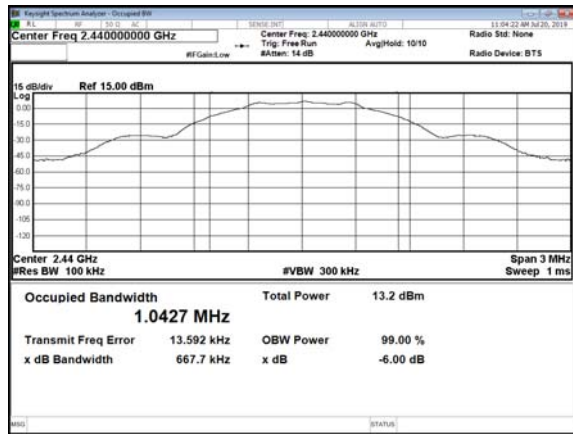

Modulation Standard: GFSK (1Mbps)
Channel: 39





Bluetooth (LE),2Mbps

Test Date: Jul. 20, 2019

Temperature: 23 °C

Atmospheric pressure: 1087 hPa

Humidity: 54 %

Modulation Type	Channel	Frequency (MHz)	6dB Bandwidth (KHz)
GFSK	00	2402	1137.0
	19	2440	1131.0
	39	2480	1129.0

Modulation Standard: GFSK (1Mbps)
Channel: 00

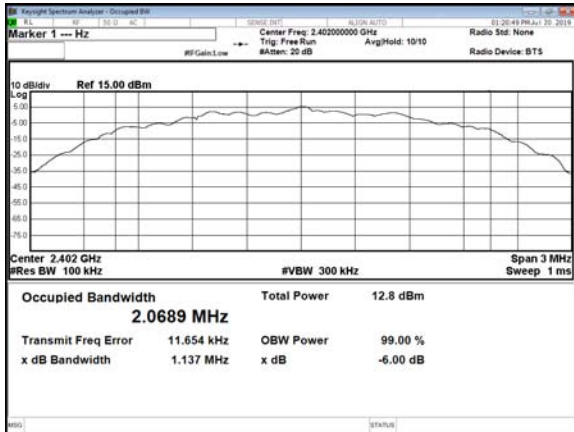

Modulation Standard: GFSK (1Mbps)
Channel: 19

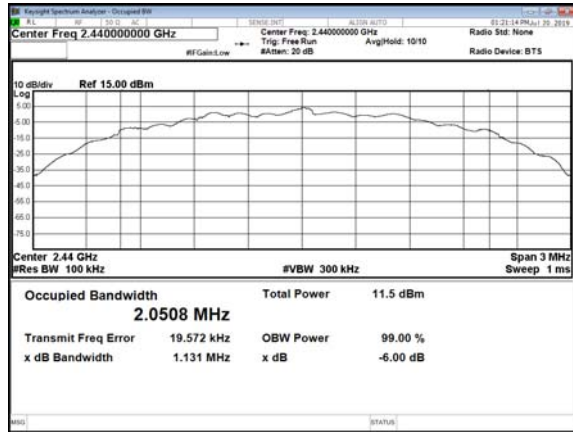

Modulation Standard: GFSK (1Mbps)
Channel: 39

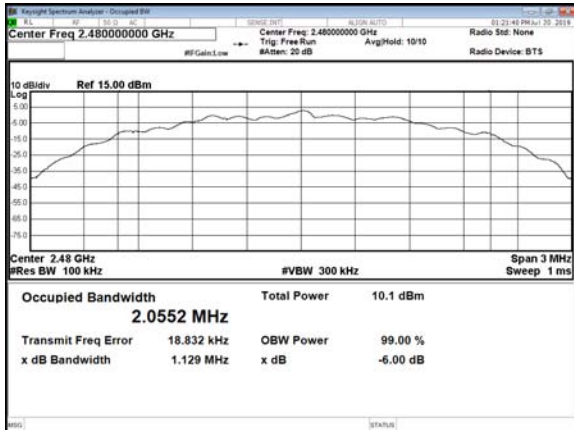



9. Maximum Peak Output Power

9.1 Test Limit

The Maximum Peak Output Power Measurement is 30dBm.

9.2 Test Procedure

Test procedure refers to KDB 558074 D01 DTS Meas Guidance v03r05 Peak power meter method.

The antenna port (RF output) of the EUT was connected to the input (RF input) of a power meter. Power was read directly from the meter and cable loss connection was added to the reading to obtain power at the EUT antenna terminal. The EUT Output Power was set to maximum to produce the worse case test result.

9.3 Test Setup Layout

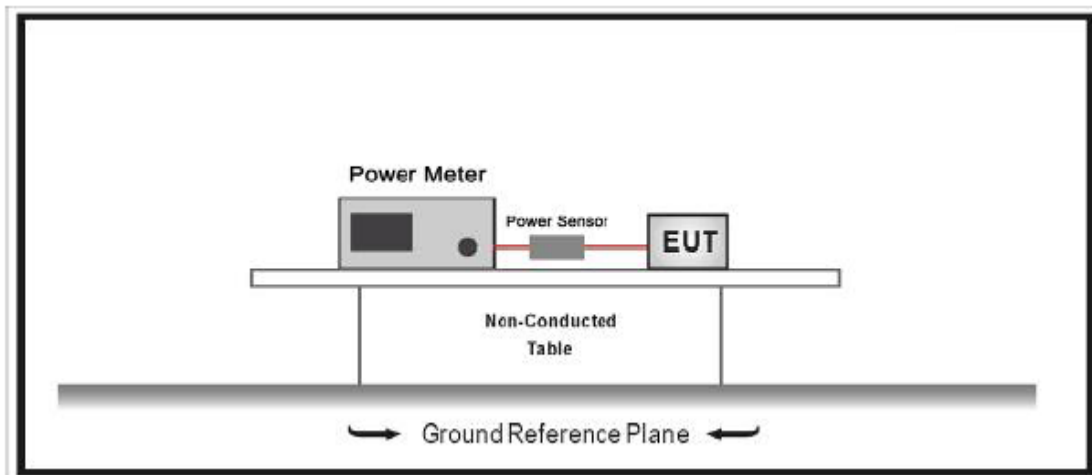



9.4 Test Result and Data

Test Date:Jul. 20, 2019

Temperature: 23°C

Atmospheric pressure: 1087 hPa

Humidity: 54%

Bluetooth (LE),1Mbps

Modulation Standard	Channel	Frequency (MHz)	Power Output (dBm)	Peak Power Output (mW)
GFSK	00	2402	8.81	7.603
	19	2440	7.74	5.943
	39	2480	6.41	4.375

Test Date:Jul. 20, 2019

Temperature: 23°C

Atmospheric pressure: 1087 hPa

Humidity: 54%

Bluetooth (LE),2Mbps

Modulation Standard	Channel	Frequency (MHz)	Power Output (dBm)	Peak Power Output (mW)
GFSK	00	2402	7.41	5.508
	19	2440	6.14	4.111
	39	2480	4.82	3.034



10. Power Spectral Density

10.1 Test Limit

The Maximum of Power Spectral Density Measurement is 8dBm.

10.2 Test Procedure

- a. The transmitter output was connected to spectrum analyzer.
- b. The spectrum analyzer's resolution bandwidth were set at 3KHz RBW and 30KHz VBW as that of the fundamental frequency. Set the sweep time=auto couple.
- c. The power spectral density was measured and recorded.

10.3 Test Setup Layout

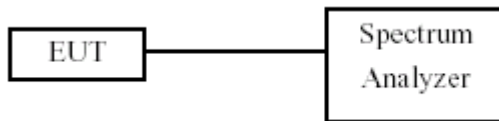



10.4 Test Result and Data

Test Date:Jul. 20 2019

Temperature: 23°C

Atmospheric pressure: 1087 hPa

Humidity: 54%

Bluetooth (LE),1Mbps

Modulation Standard	Channel	Frequency (MHz)	Maximum Power Density of 3 kHz Bandwidth (dBm)
GFSK	00	2402	-8.799
	19	2440	-9.349
	39	2480	-10.94

Modulation Standard: GFSK (1Mbps)
Channel: 00

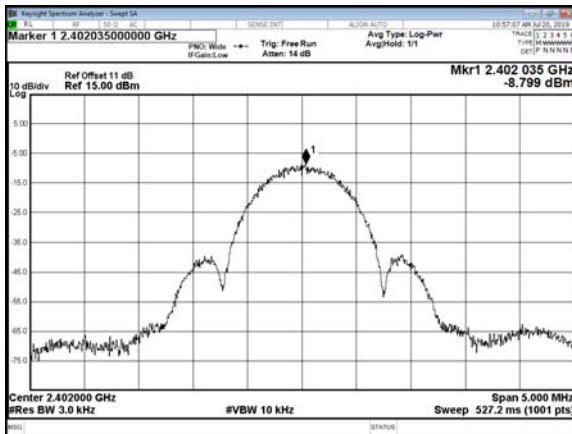

Modulation Standard: GFSK (1Mbps)
Channel: 19

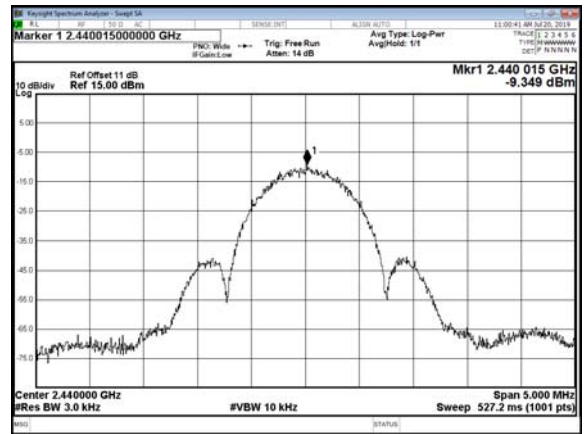

Modulation Standard: GFSK (1Mbps)
Channel: 39

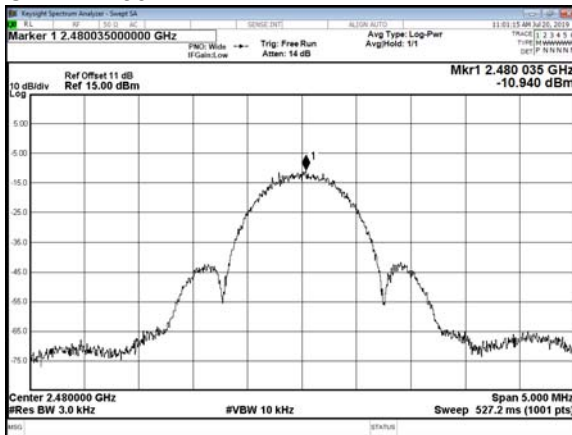



Test Date:Jul. 20 2019

Temperature: 23°C

Atmospheric pressure: 1087 hPa

Humidity: 54%

Bluetooth (LE),2Mbps

Modulation Standard	Channel	Frequency (MHz)	Maximum Power Density of 3 kHz Bandwidth (dBm)
GFSK	00	2402	-13.113
	19	2440	-13.851
	39	2480	-15.345

Modulation Standard: GFSK (1Mbps)
Channel: 00

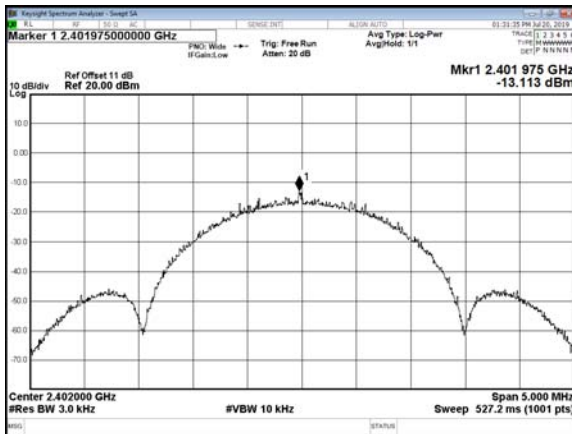

Modulation Standard: GFSK (1Mbps)
Channel: 19

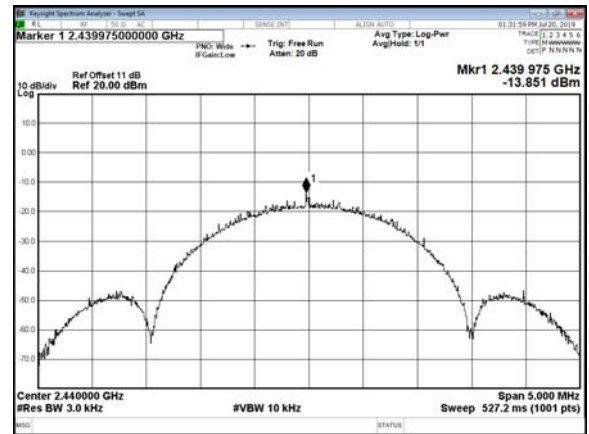

Modulation Standard: GFSK (1Mbps)
Channel: 39

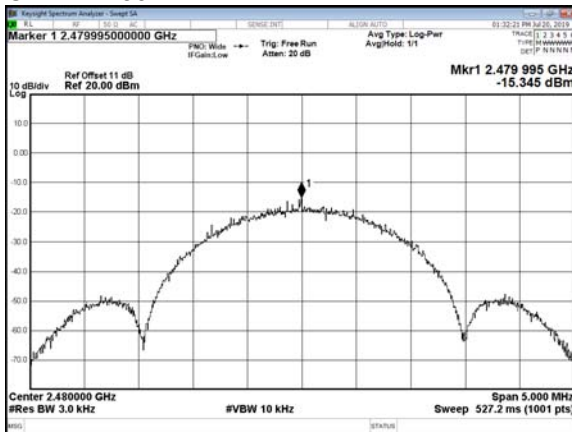

----- End of the report -----