



FCC TEST REPORT

According to

CFR47 §15.247

Applicant : Guangzhou Shirui Electronics Co.,Ltd.
Address : 192 Kezhu Road, Sciencetech Park, Guangzhou Economic & Technology Development District, Guangzhou,Guangdong,China
Manufacturer : Guangzhou Shirui Electronics Co.,Ltd.
Address : 192 Kezhu Road, Sciencetech Park, Guangzhou Economic & Technology Development District, Guangzhou,Guangdong,China
Equipment : WiFi/BT Module
Model No. : WF-R22C-USA1
Brand : seewo
FCC ID : 2AFG6-WF-R22C-USA1
Test Period : Jul. 04, 2019~ Jul. 25, 2019

- The test result refers exclusively to the test presented test model / sample.
- Without written approval of **Cerpass Technology (Suzhou) Co., Ltd.**, the test report shall not be reproduced exc- ept in full.
- The test report must not be used by the clients to claim product certification approval by any agency of the Government.

I **HEREBY** CERTIFY THAT :

The measurements shown in this test report were made in accordance with the procedures given in **ANSI C63.10 – 2013& FCC Part15.247** and the energy emitted by this equipment was **passed**.

Approved by:

Miro Chueh
EMC/RF Manager

Laboratory Accreditation:

Cerpass Technology Corporation Test Laboratory

**TAF LAB Code: 1439**

Cerpass Technology (SuZhou) Co., Ltd.

**A2LA LAB Code: 4981.01**



Contents

1. Report of Measurements and Examinations	5
2. General Info.....	6
2.1 Description of EUT.....	6
2.2 Carrier Frequency of Channels.....	7
2.3 The Worst Case Configuration.....	7
2.4 Test Mode & Test Software	8
2.5 Description of Test System	8
3. General Information of Test Site	9
3.1 Information of Test Site	9
3.2 Measuring Equipment.....	10
3.3 Measurement Uncertainty.....	11
4. AC Conducted Emission Measurement	13
4.1 Test Limit.....	13
4.2 Test Procedures	13
4.3 Typical Test Setup.....	13
4.4 Test Result and Data.....	14
5. Radiated Emission Measurement.....	16
5.1 Test Limit.....	16
5.2 Test Standard	17
5.3 Test Procedures.....	17
5.4 Typical Test Setup	17
5.5 Test Result and Data.....	19
6. 20dB Bandwidth Measurement	39
6.1 Test Limit.....	39
6.2 Test Standard	39
6.3 Test Setup	39
6.4 Test Setup Layout	39
6.5 Test Result and Data.....	40
7. Channel Carrier Frequencies Separation Measurement	43
7.1 Test Limit.....	43
7.2 Test Standard	43
7.3 Test Setup	43
7.4 Test Setup Layout	43
7.5 Test Result and Data.....	44
8. Dwell Time Measurement.....	46
8.1 Test Limit.....	46
8.2 Test Standard	46
8.3 Test Setup	46
8.4 Test Setup Layout	46
8.5 Test Result and Data.....	47
9. Number of Hopping Channels Measurement	52
9.1 Test Limit.....	52
9.2 Test Standard	52



9.3 Test Setup 52

9.4 Test Setup Layout 52

9.5 Test Result and Data 53

10. Peak Output Power Measurement 54

10.1 Test Limit 54

10.2 Test Standard 54

10.3 Test Setup 54

10.4 Test Setup Layout 55

10.5 Test Result and Data 56

11. Conducted Spurious Emissions Measurement 59

11.1 Limit 59

11.2 Test Procedure 60

11.3 Test Setup 60

11.4 Test Result 61

12. Radiated Emission Band Edge Measurement 66

12.1 Limit 66

12.2 Test Procedure 66

12.3 Test Setup 67

12.4 Test Result 68



History of this Test Report

Report No.	Version	Issue Date	Description
SEFB1907135	Rev 01	Jul. 25, 2019	Original



1. Report of Measurements and Examinations

FCC Rule	Description of Test	Result
§ 15.203	. Antenna Requirement	Pass
§ 15.207(a)	. Conducted Emission	Pass
§ 15.209(a)	. Radiated Emission	Pass
§ 15.247(a)(1)	. Channel Carrier Frequencies Separation	Pass
§ 15.247(a)(1)	. 20dB Bandwidth Measurement	Pass
§ 15.247(a)(1)	. Dwell Time	Pass
§ 15.247(b)	. Number of Hopping Channels	Pass
§ 15.247(b)	. Peak Output Power Measurement Data	Pass
§ 15.247(d)	. Band Edges Measurement Data	Pass



2. General Info

2.1 Description of EUT

Product name	WiFi/BT Module
Model No.	WF-R22C-USA1
Model Discrepancy	N/A
Power supply	DC3.3V
Frequency Range	2402~2480MHz
Number of Channels	79
Modulation	GFSK (1Mbps), $\pi/4$ DQPSK (2Mbps) and 8DPSK (3Mbps)
Data Rates	Bluetooth: 1, 2, 3Mbps,
Antenna Spec.	Dipole Antenna with 3.18dBi

Note: For more details, please refer to the User's manual of the EUT.



2.2 Carrier Frequency of Channels

Bluetooth Working Frequency of Each Channel:							
Channel	Frequency	Channel	Frequency	Channel	Frequency	Channel	Frequency
00	2402 MHz	01	2403 MHz	02	2404 MHz	03	2405 MHz
04	2406 MHz	05	2407 MHz	06	2408 MHz	07	2409 MHz
08	2410 MHz	09	2411 MHz	10	2412 MHz	11	2413 MHz
12	2414 MHz	13	2415 MHz	14	2416 MHz	15	2417 MHz
16	2418 MHz	17	2419 MHz	18	2420 MHz	19	2421 MHz
20	2422 MHz	21	2423 MHz	22	2424 MHz	23	2425 MHz
24	2426 MHz	25	2427 MHz	26	2428 MHz	27	2429 MHz
28	2430 MHz	29	2431 MHz	30	2432 MHz	31	2433 MHz
32	2434 MHz	33	2435 MHz	34	2436 MHz	35	2437 MHz
36	2438 MHz	37	2439 MHz	38	2440 MHz	39	2441 MHz
40	2442 MHz	41	2443 MHz	42	2444 MHz	43	2445 MHz
44	2446 MHz	45	2447 MHz	46	2448 MHz	47	2449 MHz
48	2450 MHz	49	2451 MHz	50	2452 MHz	51	2453 MHz
52	2454 MHz	53	2455 MHz	54	2456 MHz	55	2457 MHz
56	2458 MHz	57	2459 MHz	58	2460 MHz	59	2461 MHz
60	2462 MHz	61	2463 MHz	62	2464 MHz	63	2465 MHz
64	2466 MHz	65	2467 MHz	66	2468 MHz	67	2469 MHz
68	2470 MHz	69	2471 MHz	70	2472 MHz	71	2473 MHz
72	2474 MHz	73	2475 MHz	74	2476 MHz	75	2477 MHz
76	2478 MHz	77	2479 MHz	78	2480 MHz	N/A	N/A

2.3 The Worst Case Configuration

Data rate Configuration:

Test Mode	
DH5	√
2DH5	√
3DH5	√



2.4 Test Mode & Test Software

- a. During testing, the interface cables and equipment positions were varied according to ANSI C63.10
- b. The complete test system included support units and EUT for RF test.
- c. Run the test software “**BT:RTLBAPP.exe**”.
- d. The following test mode was performed for conduction and radiation test:
Test Mode 1: GFSK: CH 00: 2402MHz, CH 39: 2441MHz, CH 78: 2480MHz.
Test Mode 2: $\pi/4$ DQPSK : CH 00: 2402MHz, CH 39: 2441MHz, CH 78: 2480MHz.
Test Mode 3: 8DPSK: CH 00: 2402MHz, CH 39: 2441MHz, CH 78: 2480MHz.

2.5 Description of Test System

No	Device	Manufacturer	Model No.	Description
1	Notebook	SONY	PCG-71811P	R33021

Use Cable:

No.	Cable	Quantity	Description
1	USB Cable	1	1.7m Shielding



3. General Information of Test Site

3.1 Information of Test Site

<input type="checkbox"/>	Test Site	CerpPASS Technology Corporation Test Laboratory Address: No.10, Ln. 2, Lianfu St., Luzhu Dist., Taoyuan City 33848, Taiwan (R.O.C.) Tel:+886-3-3226-888 Fax:+886-3-3226-881 Address: No.68-1, Shihbachongsi, Shihding Township, New Taipei City 223, Taiwan, R.O.C. Tel: +886-2-2663-8582
	TAF	1439
	FCC	TW1079, TW1061
	IC	4934E-1, 4934E-2
	VCCI	T-2205 for Telecommunication Test C-4663 for Conducted emission test R-4399, R-4218 for Radiated emission test G-812, G-813 for radiated disturbance above 1GHz
<input checked="" type="checkbox"/>	Test Site	CerpPASS Technology (Suzhou) Co.,Ltd Address: No.66,Tangzhuang Road, Suzhou Industrial Park, Jiangsu 215006, China Tel: +86-512-6917-5888 Fax: +86-512-6917-5666
	CNAS	L5515
	FCC	CN1243
	A2LA	4981.01
	IC	7290A-1, 7290A-2
	VCCI	T-1945 for Telecommunication Test C-2919 for Conducted emission test R-2670 for Radiated emission test G-227 for radiated disturbance above 1GHz



3.2 Measuring Equipment

Instrument/Ancillary	Manufacturer	Model No.	Serial No.	Calibration Date	Valid Date.
EMI Receiver	R&S	ESCI3	100563	2019.06.21	2020.06.20
LISN	Schwarzbeck	NSLK 8127	8127-920	2018.09.25	2019.09.24
Pulse Limiter	R&S	ESH3-Z2	100529	2019.03.11	2020.03.10
Software	Farad	Ez-EMC	ver.ct3a1	N/A	N/A

Instrument/Ancillary	Manufacturer	Model No.	Serial No.	Calibration Date	Valid Date.
Bilog Antenna	Sunol	JB1	A072414-2 -2	2019.07.13	2020.07.13
EMI Receiver	R&S	ESCI3	101183	2019.06.28	2020.06.27
EMI Receiver	R&S	ESCI7	100968	2018.07.30	2019.07.29
Preamplifier	EM Electronics corp.	EM330	60618	2019.03.11	2020.03.10
Horn Antenna	Schwarzbeck	BBHA9120 D	9120D-619	2019.07.13	2020.07.13
Horn Antenna	Schwarzbeck	BBHA9170	9170-348	2019.06.23	2020.06.22
Spectrum Analyzer	R&S	FSP40	100324	2019.07.13	2020.07.12
Preamplifier	EMCI	EMCI 030-00-3230	SN016723	2019.03.11	2020.03.10
Preamplifier	EM Electronics corp.	EM01G18G	SN060714	2019.03.23	2020.03.22
Spectrum Analyzer	KEYSIGHT	N9010A	MY53400169	2018.08.25	2019.08.24
Software	E3	AUDIX	Version: 8.14.806b	N/A	N/A



3.3 Measurement Uncertainty

ISO/IEC 17025 requires that an estimate of the measurement uncertainties associated with the emissions test results be included in the report. The measurement uncertainties given below are based on a 95% confidence level (based on a coverage factor (k=2)).

RF Conducted Measurement

Test Item		Uncertainty	Limit
Radio Frequency		$\pm 8.7 \times 10^{-7}$	$\pm 1 \times 10^{-5}$
RF output power, conducted		$\pm 0.63\text{dB}$	$\pm 1.5\text{dB}$
Power density, conducted		$\pm 1.21\text{dB}$	$\pm 3\text{dB}$
Unwanted emissions, conducted	30-1000MHz	$\pm 0.51\text{dB}$	$\pm 3\text{dB}$
	1-12.75GHz	$\pm 0.67\text{dB}$	$\pm 3\text{dB}$
All emissions, radiated	30-1000MHz	$\pm 2.28\text{dB}$	$\pm 6\text{dB}$
	1-12.75GHz	$\pm 2.59\text{dB}$	$\pm 6\text{dB}$
Temperature		$\pm 0.8^\circ\text{C}$	$\pm 1^\circ\text{C}$
Humidity		$\pm 3\%$	$\pm 5\%$
DC and low frequency voltages		$\pm 3\%$	$\pm 3\%$

AC Conducted Measurement

Measurement	Frequency	Uncertainty
Conducted emissions(LINE)	9KHz-30MHz	+/- 0.7738 dB
Conducted emissions(NEUTRAL)	9KHz-30MHz	+/- 0.7886 dB
Conducted emissions(10Mbps)	150KHz-30MHz	+/- 1.3013dB
Conducted emissions(100Mbps)	150KHz-30MHz	+/- 1.3197 dB
Conducted emissions(1000Mbps)	150KHz-30MHz	+/- 1.2987 dB

Radiated Measurement

Measurement	Polarity	Frequency	Uncertainty
Radiated emissions	Horizontal	below 1GHz	+/- 3.8936 dB
	Vertical	below 1GHz	+/- 3.8928 dB
	Horizontal	above 1GHz	+/- 5.18858dB
	Vertical	above 1GHz	+/- 5.18928 dB



4. AC Conducted Emission Measurement

4.1 Test Limit

Conducted Emissions were measured from 150 kHz to 30 MHz with a bandwidth of 9 KHz on the 120 VAC power and return leads of the EUT according to the methods defined in ANSI C63.10-2013 Section 6.2. The EUT was placed on a nonmetallic stand in a shielded room 0.8 meters above the ground plane as shown in section 6.2.2. The interface cables and equipment positioning were varied within limits of reasonable applications to determine the position produced maximum conducted emissions.

Frequency (MHz)	Quasi Peak (dB μ V)	Average (dB μ V)
0.15 – 0.5	66-56*	56-46*
0.5 – 5.0	56	46
5.0 – 30.0	60	50

*Decreases with the logarithm of the frequency.

4.2 Test Procedures

- The EUT was placed 0.4 meter from the conducting wall of the shielding room was kept at least 80 centimeters from any other grounded conducting surface.
- Connect EUT to the power mains through a line impedance stabilization network (LISN).
- All the support units are connecting to the other LISN.
- The LISN provides 50 ohm coupling impedance for the measuring instrument.
- The FCC states that a 50 ohm, 50 micro-Henry LISN should be used.
- Both sides of AC line were checked for maximum conducted interference.
- The frequency range from 150 kHz to 30 MHz was searched.
- Set the test-receiver system to Peak Detect Function and Specified Bandwidth with Maximum Hold Mode.

4.3 Typical Test Setup

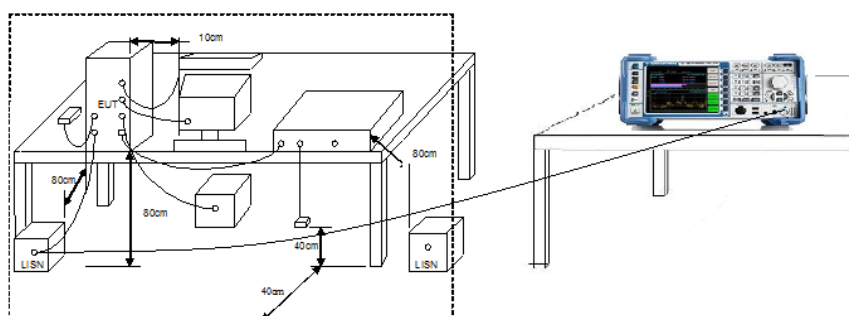



4.4 Test Result and Data

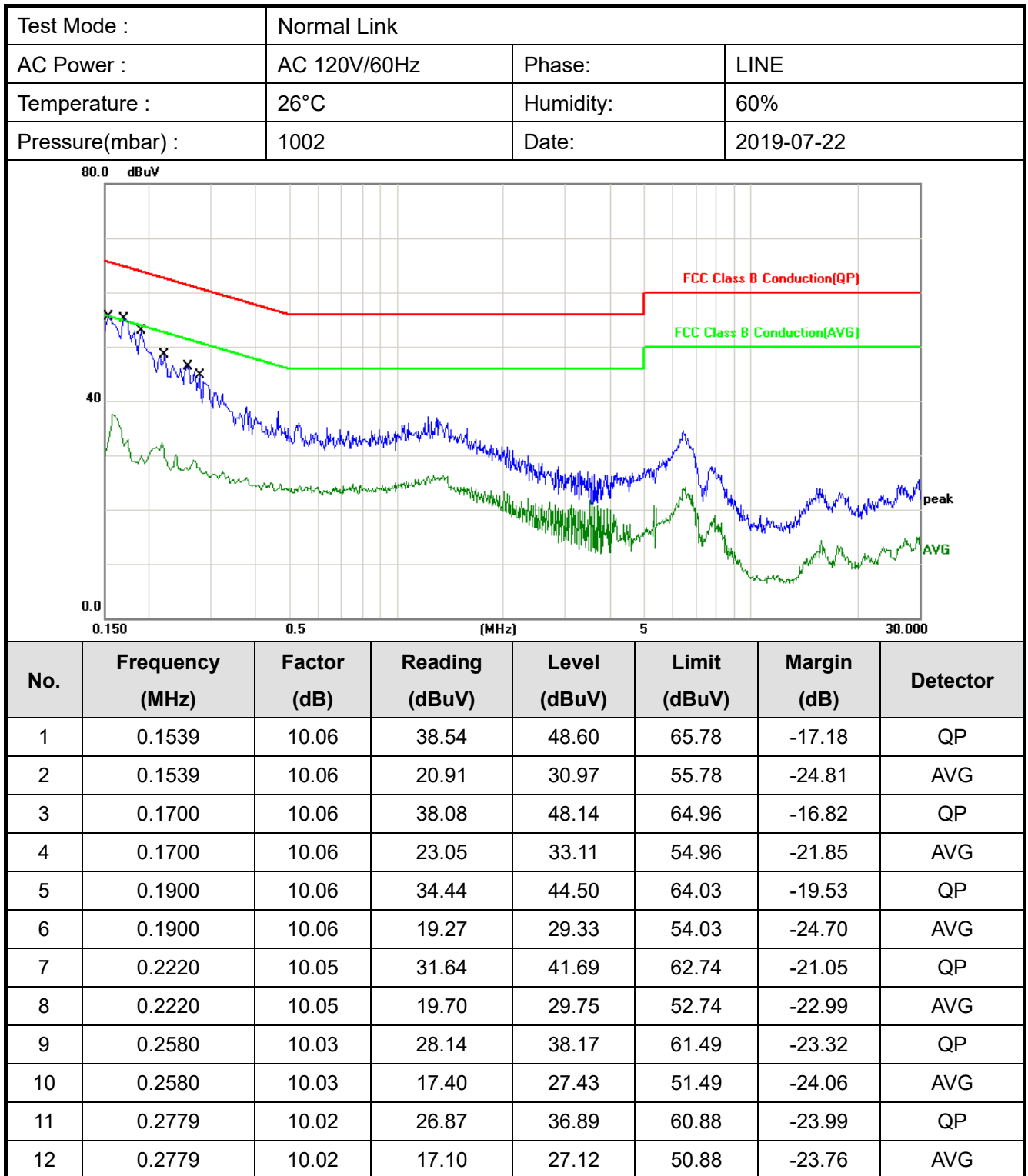

Note: Measurement Level = Reading Level + Correct Factor



Test Mode :	Normal Link		
AC Power :	AC 120V/60Hz	Phase:	NEUTRAL
Temperature :	26°C	Humidity:	60%
Pressure(mbar) :	1002	Date:	2019-07-22

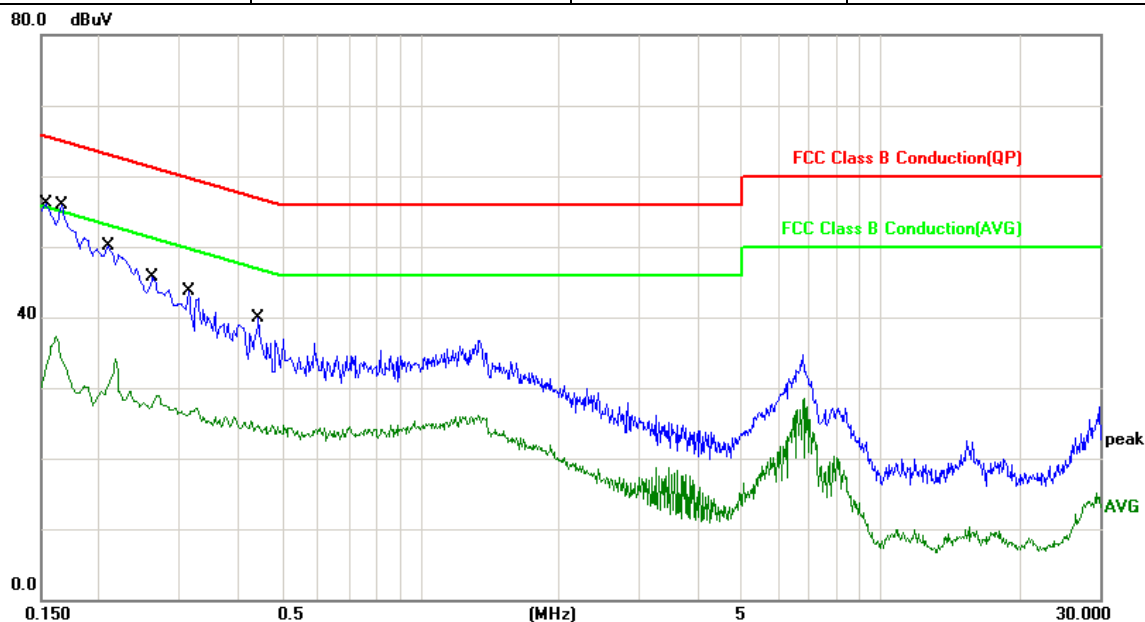

No.	Frequency (MHz)	Factor (dB)	Reading (dBuV)	Level (dBuV)	Limit (dBuV)	Margin (dB)	Detector
1	0.1539	10.06	38.42	48.48	65.78	-17.30	QP
2	0.1539	10.06	21.56	31.62	55.78	-24.16	AVG
3	0.1660	10.06	38.35	48.41	65.15	-16.74	QP
4	0.1660	10.06	25.31	35.37	55.15	-19.78	AVG
5	0.2100	10.05	32.02	42.07	63.20	-21.13	QP
6	0.2100	10.05	19.92	29.97	53.20	-23.23	AVG
7	0.2620	10.02	27.51	37.53	61.36	-23.83	QP
8	0.2620	10.02	17.50	27.52	51.36	-23.84	AVG
9	0.3140	10.00	24.05	34.05	59.86	-25.81	QP
10	0.3140	10.00	16.14	26.14	49.86	-23.72	AVG
11	0.4460	9.92	20.17	30.09	56.95	-26.86	QP
12	0.4460	9.92	14.21	24.13	46.95	-22.82	AVG



5. Radiated Emission Measurement

5.1 Test Limit

In any 100kHz bandwidth outside the frequency band in which the spread spectrum or digitally modulated intentional radiator is operating, the radio frequency power that is produced by the intentional radiator shall be at least 20dB below that in the 100kHz bandwidth within the band that contains the highest level of the desired power, based on either an RF conducted or a radiated measurement. If the transmitter measurement is based on the maximum conducted output power, the attenuation required under this paragraph shall be 30dB instead of 20dB. In addition, radiated emissions which fall in section 15.205(a) the restricted bands must also comply with the radiated emission limit specified in section 15.209(a).

FREQUENCIES (MHz)	FIELD STRENGTH (micro volts/meter)	MEASUREMENT DISTANCE (meters)
0.009~0.490	2400/F(kHz)	300
0.490~1.705	24000/F(kHz)	30
1.705~30.0	30	30
30~88	100	3
88~216	150	3
216~960	200	3
Above 960	500	3

For unintentional device, according to CISPR PUB.22, for Class B digital devices, the general requirement of field strength of radiated emissions from intentional radiators at a distance of 10 meters shall not exceed the above table.

Frequency (MHz)	Distance Meters	Radiated (dB μ V/ M)
30-230	10	30
230-1000	10	37



5.2 Test Standard

ANSI C63.10-2013-Section 6.10.5

5.3 Test Procedures

- a. The EUT was placed on a rotatable table top 0.8 meter for frequency below 1GHz and 1.5meter for frequency above 1GHz above ground.
- b. The EUT was set 3 meters from the interference receiving antenna which was mounted on the top of a variable height antenna tower.
- c. The table was rotated 360 degrees to determine the position of the highest radiation.
- d. The antenna is a broadband antenna and its height is varied between one meter and four meters above ground to find the maximum value of the field strength both horizontal polarization and vertical polarization of the antenna are set to make the measurement.
- e. For each suspected emission the EUT was arranged to its worst case and then tune the antenna tower (from 1 M to 4 M) and turn table (from 0 degree to 360 degrees) to find the maximum reading.
- f. Set the test-receiver system to Peak or CISPR quasi-peak Detect Function and specified bandwidth with Maximum Hold Mode.
- g. If the emission level of the EUT in peak mode was 3 dB lower than the limit specified, then testing will be stopped and peak values of EUT will be reported, otherwise, the emissions which do not have 3 dB margin will be repeated one by one using the quasi-peak method and reported.
- h. For testing above 1GHz, the emission level of the EUT in peak mode was 20dB lower than average limit (that means the emission level in peak mode also complies with the limit in average mode), then testing will be stopped and peak values of EUT will be reported, otherwise, the emissions will be measured in average mode again and reported.

5.4 Typical Test Setup

9kHz~30MHz Test Setup

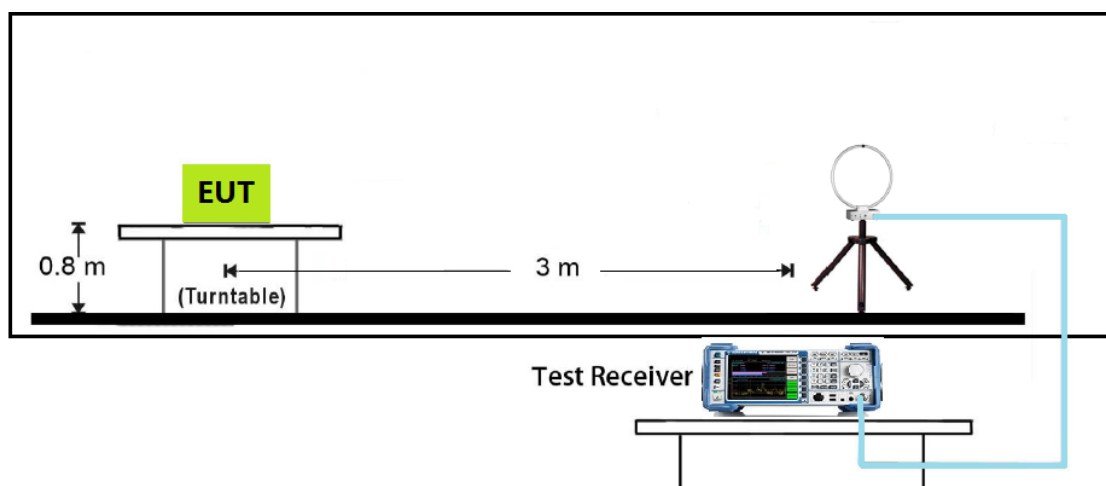



Below 1GHz Test Setup

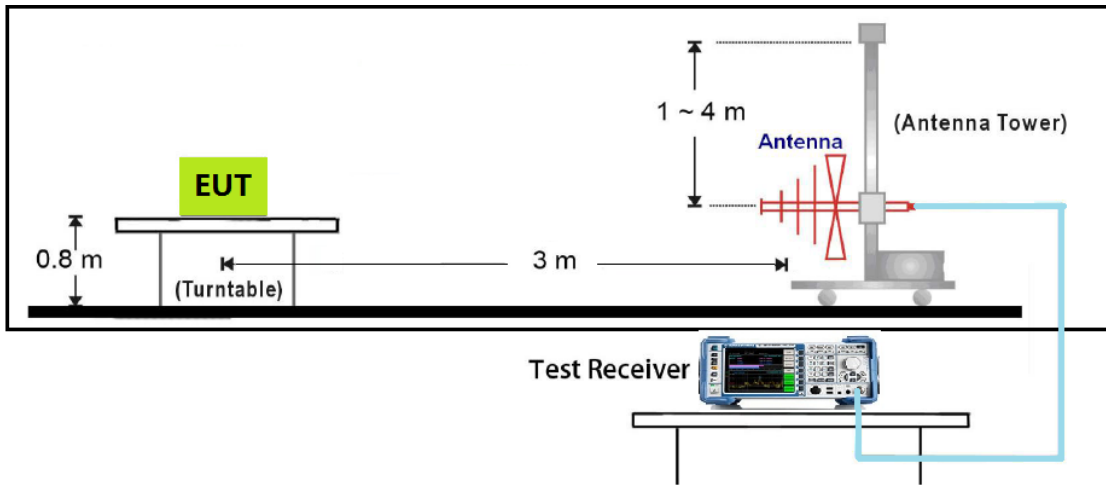

1GHz~18GHz Test Setup

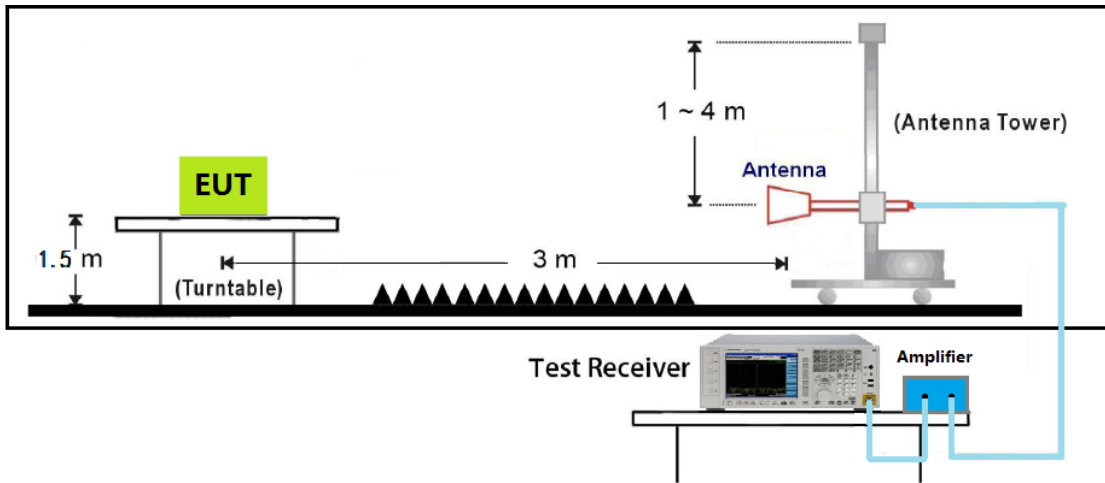

18GHz~40GHz Test Setup

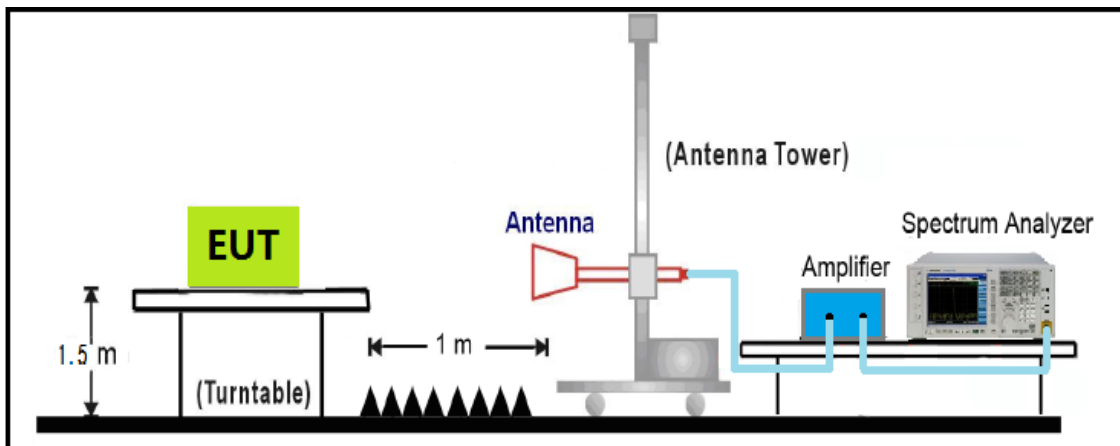



5.5 Test Result and Data

The 9kHz-30MHz spurious emission is under limit 20dB more.

Below 1GHz

Power	: DC 3.3V	Pol/Phase	: Horizontal
Test Mode	: Mode 1	Temperature	: 18 °C
Test Date	: Jul. 21, 2019	Humidity	: 49 %
Memo	: CH 00	Atmospheric Pressure	: 1008 hpa

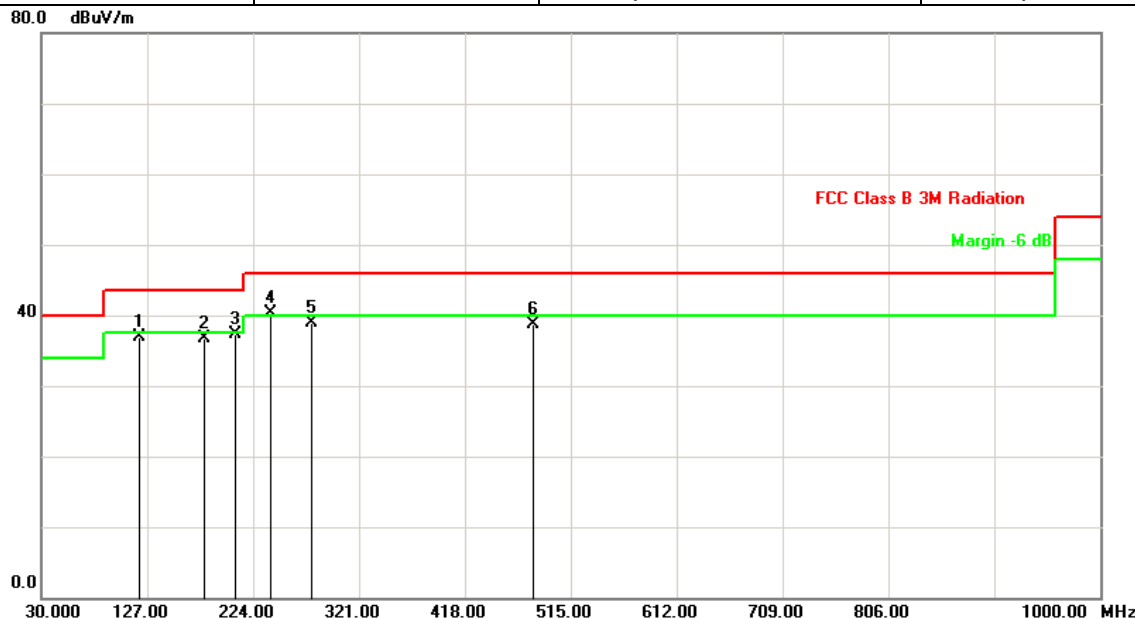

No.	Frequency (MHz)	Factor (dB/m)	Reading (dBuV)	Level (dBuV/m)	Limit (dBuV/m)	Margin (dB)	Det.	Height (cm)	Azimuth (deg)
1	119.2400	-10.36	47.22	36.86	43.50	-6.64	peak	100	57
2	179.3800	-9.97	46.59	36.62	43.50	-6.88	peak	200	103
3	207.5100	-9.62	46.85	37.23	43.50	-6.27	QP	241	68
4	240.4900	-6.98	47.20	40.22	46.00	-5.78	QP	237	116
5	277.3500	-6.51	45.36	38.85	46.00	-7.15	QP	164	78
6	481.0500	-1.97	40.77	38.80	46.00	-7.20	peak	200	159

Note: Level = Reading + Factor

Margin = Level – Limit

Factor= Antenna Factor + Cable Loss - Amplifier Factor



Power	: DC 3.3V	Pol/Phase	: VERTICAL
Test Mode	: Mode 1	Temperature	: 18 °C
Test Date	: Jul. 21, 2019	Humidity	: 49 %
Memo	: CH 00	Atmospheric Pressure	: 1008 hpa

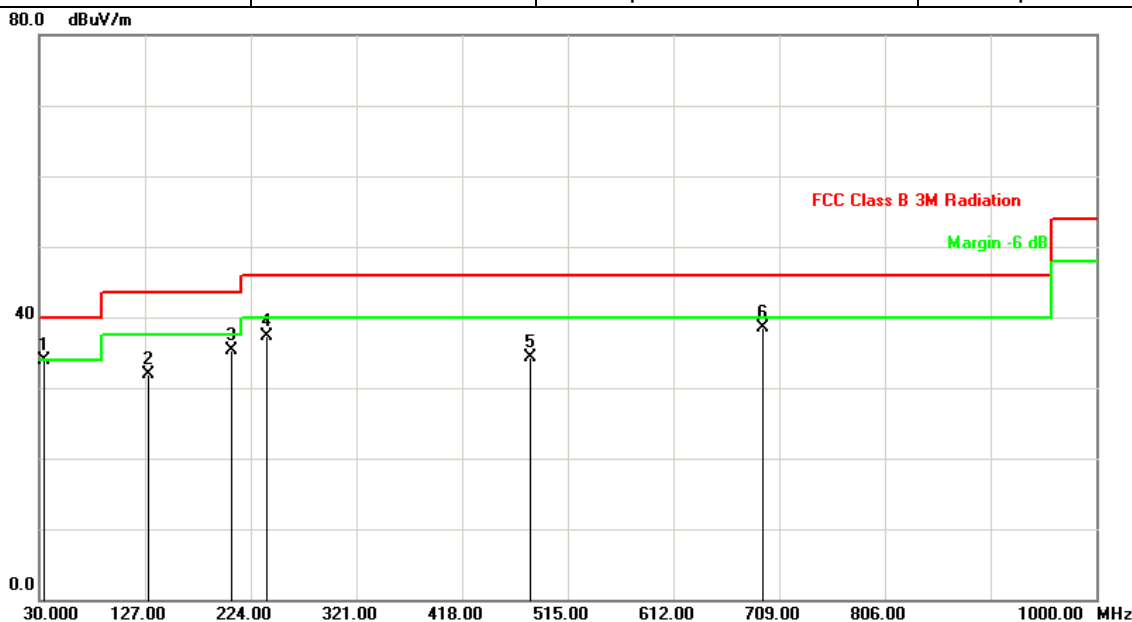

No.	Frequency (MHz)	Factor (dB/m)	Reading (dBuV)	Level (dBuV/m)	Limit (dBuV/m)	Margin (dB)	Det.	Height (cm)	Azimuth (deg)
1	33.8800	-7.99	41.88	33.89	40.00	-6.11	peak	100	67
2	129.9100	-11.12	43.12	32.00	43.50	-11.50	peak	100	102
3	206.5399	-8.63	43.86	35.23	43.50	-8.27	peak	100	59
4	238.5500	-8.81	46.11	37.30	46.00	-8.70	peak	100	203
5	481.0500	-1.97	36.26	34.29	46.00	-11.71	peak	100	158
6	693.4800	-2.22	40.64	38.42	46.00	-7.58	peak	100	12

Note: Level = Reading + Factor
 Margin = Level – Limit
 Factor= Antenna Factor + Cable Loss - Amplifier Factor



Radiated Emission above 1GHz:

Power	: DC 3.3V	Pol/Phase	: HORIZONTAL
Test Mode	: Mode 1	Temperature	: 25 °C
Test Date	: Jul. 14, 2019	Humidity	: 52 %
Memo	: CH 00	Atmospheric Pressure	: 1010 hpa

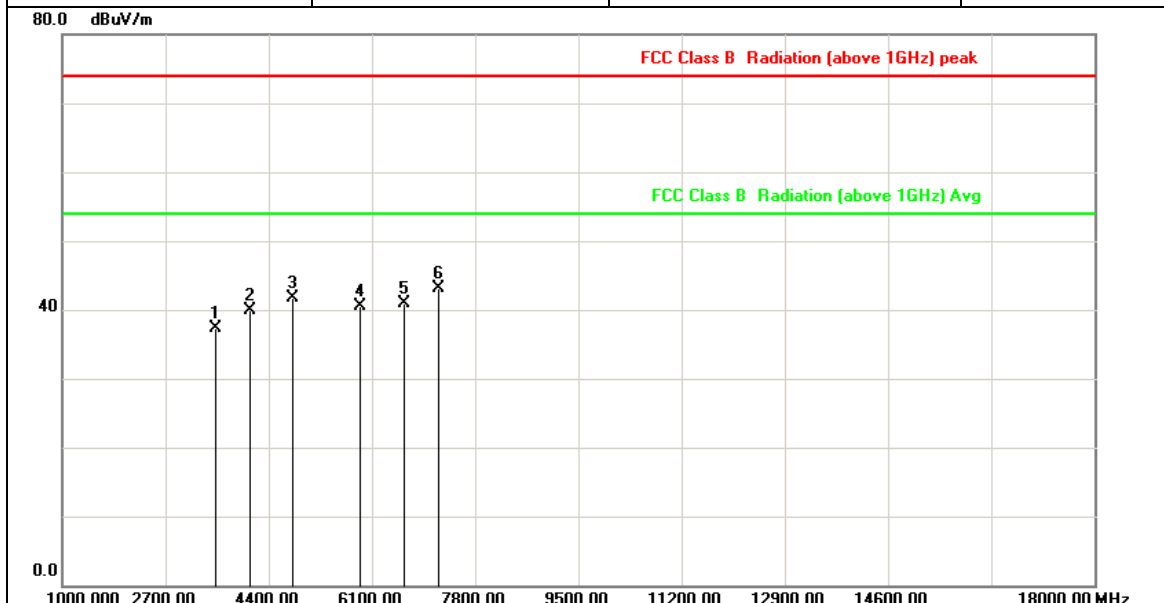

No.	Frequency (MHz)	Factor (dB/m)	Reading (dBuV)	Level (dBuV/m)	Limit (dBuV/m)	Margin (dB)	Detector
1	3521.667	-3.53	40.86	37.33	74.00	-36.67	peak
2	4088.333	-1.44	41.39	39.95	74.00	-34.05	peak
3	4804.000	1.23	40.51	41.74	74.00	-32.26	peak
4	5901.667	3.02	37.52	40.54	74.00	-33.46	peak
5	6638.333	3.91	37.00	40.91	74.00	-33.09	peak
6	7206.000	5.88	37.17	43.05	74.00	-30.95	peak

Note: Level = Reading + Factor
 Margin = Level – Limit
 Factor= Antenna Factor + Cable Loss - Amplifier Factor



Power	: DC 3.3V	Pol/Phase	: Vertical
Test Mode	: Mode 1	Temperature	: 25 °C
Test Date	: Jul. 14, 2019	Humidity	: 52 %
Memo	: CH 00	Atmospheric Pressure	: 1010 hpa

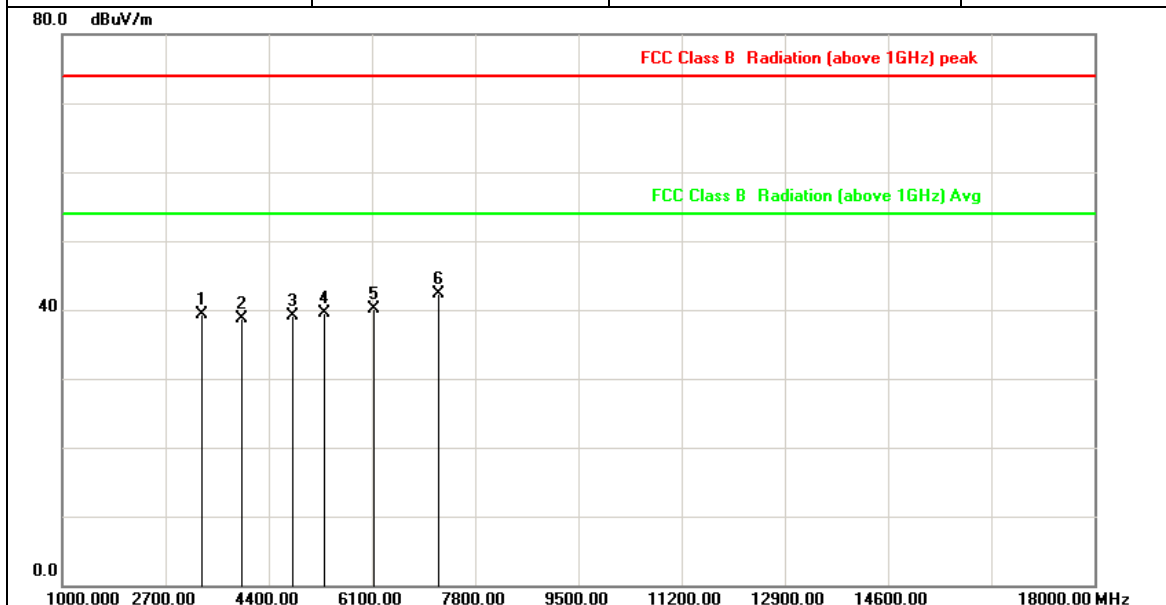

No.	Frequency (MHz)	Factor (dB/m)	Reading (dBuV)	Level (dBuV/m)	Limit (dBuV/m)	Margin (dB)	Detector
1	3295.000	-4.68	44.00	39.32	74.00	-34.68	peak
2	3946.667	-2.07	40.83	38.76	74.00	-35.24	peak
3	4804.000	1.23	37.78	39.01	74.00	-34.99	peak
4	5306.667	1.86	37.74	39.60	74.00	-34.40	peak
5	6128.333	3.31	36.83	40.14	74.00	-33.86	peak
6	7206.000	5.88	36.45	42.33	74.00	-31.67	peak

Note: Level = Reading + Factor
Margin = Level – Limit
Factor= Antenna Factor + Cable Loss - Amplifier Factor



Power	: DC 3.3V	Pol/Phase	: HORIZONTAL
Test Mode	: Mode 1	Temperature	: 25 °C
Test Date	: Jul. 14, 2019	Humidity	: 52 %
Memo	: CH 39	Atmospheric Pressure	: 1010 hpa

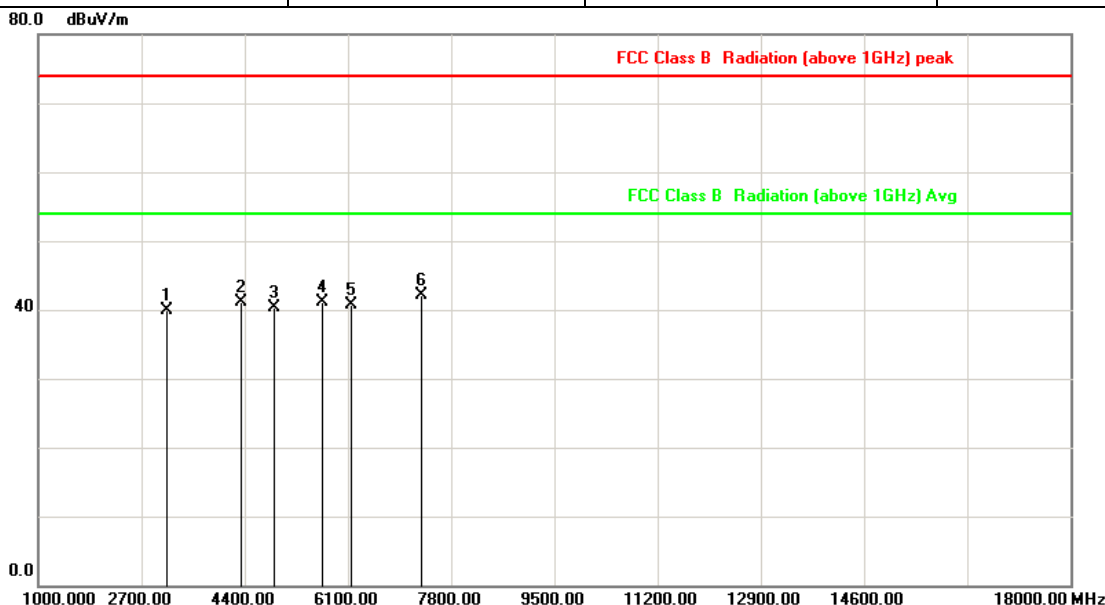

No.	Frequency (MHz)	Factor (dB/m)	Reading (dBuV)	Level (dBuV/m)	Limit (dBuV/m)	Margin (dB)	Detector
1	3125.000	-5.57	45.39	39.82	74.00	-34.18	peak
2	4343.333	-0.14	41.24	41.10	74.00	-32.90	peak
3	4882.000	1.38	38.97	40.35	74.00	-33.65	peak
4	5675.000	2.45	38.70	41.15	74.00	-32.85	peak
5	6156.667	3.32	37.37	40.69	74.00	-33.31	peak
6	7323.000	6.34	35.74	42.08	74.00	-31.92	peak

Note: Level = Reading + Factor

Margin = Level – Limit

Factor= Antenna Factor + Cable Loss - Amplifier Factor



Power	: DC 3.3V	Pol/Phase	: Vertical
Test Mode	: Mode 1	Temperature	: 25 °C
Test Date	: Jul. 14, 2019	Humidity	: 52 %
Memo	: CH 39	Atmospheric Pressure	: 1010 hpa

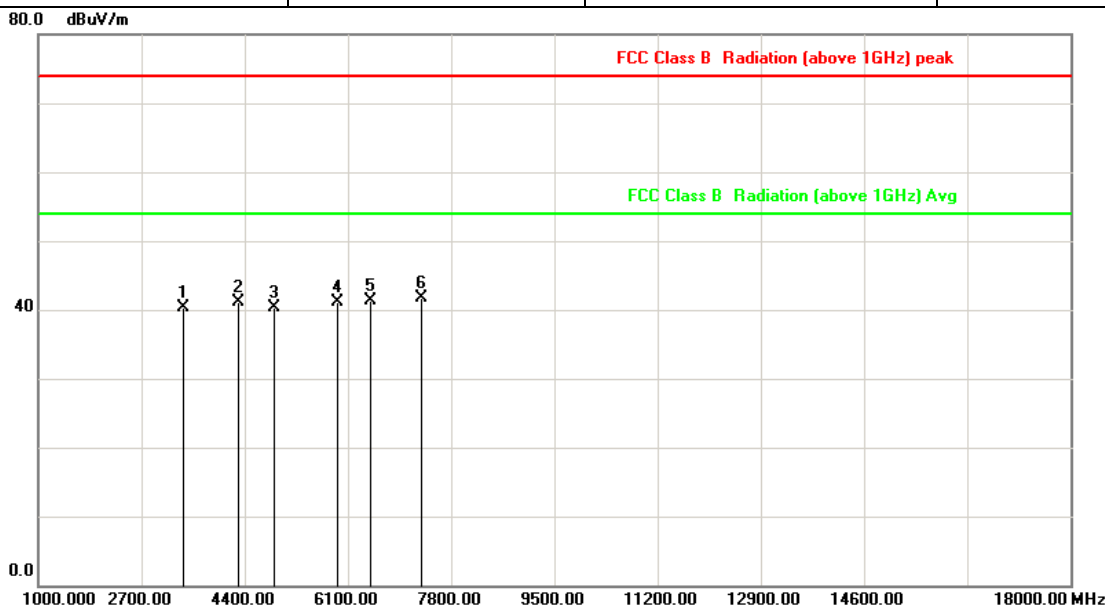

No.	Frequency (MHz)	Factor (dB/m)	Reading (dBuV)	Level (dBuV/m)	Limit (dBuV/m)	Margin (dB)	Detector
1	3380.000	-4.23	44.47	40.24	74.00	-33.76	peak
2	4286.667	-0.43	41.54	41.11	74.00	-32.89	peak
3	4882.000	1.38	38.99	40.37	74.00	-33.63	peak
4	5930.000	3.09	38.00	41.09	74.00	-32.91	peak
5	6468.333	3.45	37.82	41.27	74.00	-32.73	peak
6	7323.000	6.34	35.44	41.78	74.00	-32.22	peak

Note: Level = Reading + Factor
 Margin = Level – Limit
 Factor= Antenna Factor + Cable Loss - Amplifier Factor



Power	: DC 3.3V	Pol/Phase	: HORIZONTAL
Test Mode	: Mode 1	Temperature	: 25 °C
Test Date	: Jul. 14, 2019	Humidity	: 52 %
Memo	: CH 78	Atmospheric Pressure	: 1010 hpa

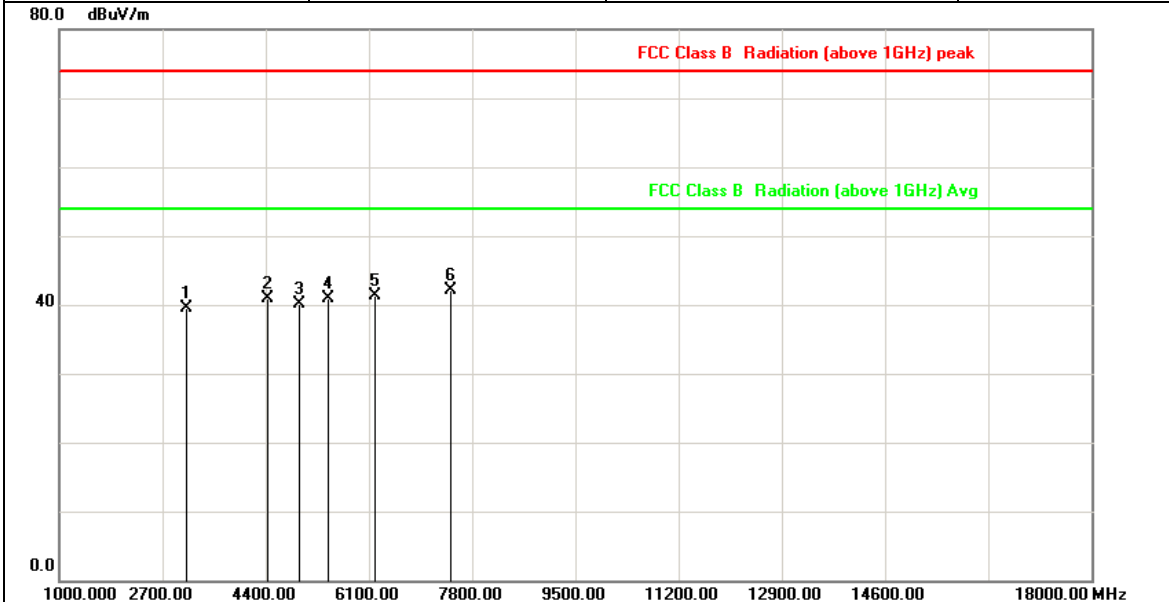

No.	Frequency (MHz)	Factor (dB/m)	Reading (dBuV)	Level (dBuV/m)	Limit (dBuV/m)	Margin (dB)	Detector
1	3096.667	-5.72	45.29	39.57	74.00	-34.43	peak
2	4428.333	0.29	40.67	40.96	74.00	-33.04	peak
3	4960.000	1.52	38.58	40.10	74.00	-33.90	peak
4	5420.000	1.95	38.90	40.85	74.00	-33.15	peak
5	6213.333	3.35	37.99	41.34	74.00	-32.66	peak
6	7440.000	6.80	35.30	42.10	74.00	-31.90	peak

Note: Level = Reading + Factor
Margin = Level – Limit
Factor= Antenna Factor + Cable Loss - Amplifier Factor



Power	: DC 3.3V	Pol/Phase	: Vertical
Test Mode	: Mode 1	Temperature	: 25 °C
Test Date	: Jul. 14, 2019	Humidity	: 52 %
Memo	: CH 78	Atmospheric Pressure	: 1010 hpa

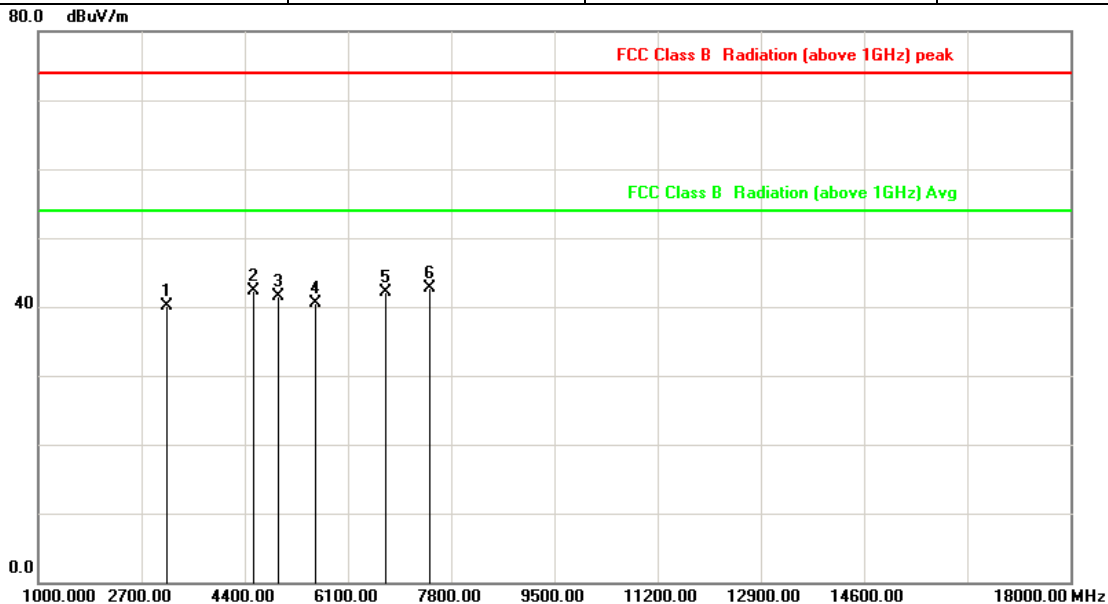

No.	Frequency (MHz)	Factor (dB/m)	Reading (dBuV)	Level (dBuV/m)	Limit (dBuV/m)	Margin (dB)	Detector
1	3125.000	-5.57	45.67	40.10	74.00	-33.90	peak
2	4541.667	0.74	41.64	42.38	74.00	-31.62	peak
3	4960.000	1.52	40.06	41.58	74.00	-32.42	peak
4	5561.667	2.17	38.26	40.43	74.00	-33.57	peak
5	6723.333	4.18	37.85	42.03	74.00	-31.97	peak
6	7440.000	6.80	35.94	42.74	74.00	-31.26	peak

Note: Level = Reading + Factor
 Margin = Level – Limit
 Factor= Antenna Factor + Cable Loss - Amplifier Factor



Power	: DC 3.3V	Pol/Phase	: HORIZONTAL
Test Mode	: Mode 2	Temperature	: 25 °C
Test Date	: Jul. 14, 2019	Humidity	: 52 %
Memo	: CH 00	Atmospheric Pressure	: 1010 hpa

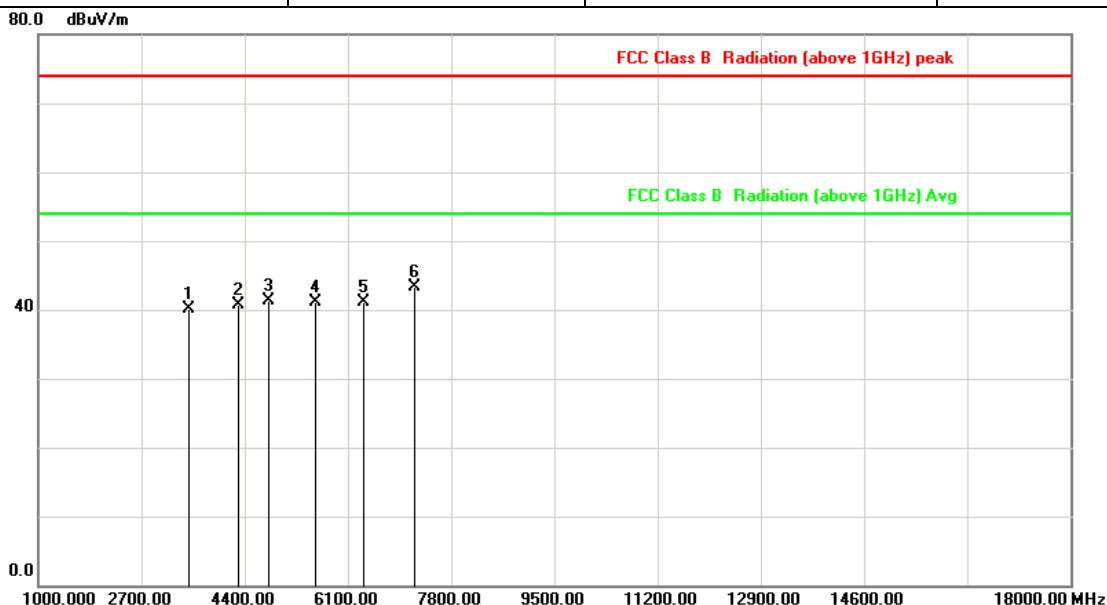

No.	Frequency (MHz)	Factor (dB/m)	Reading (dBuV)	Level (dBuV/m)	Limit (dBuV/m)	Margin (dB)	Detector
1	3493.333	-3.64	43.75	40.11	74.00	-33.89	peak
2	4286.667	-0.43	41.22	40.79	74.00	-33.21	peak
3	4804.000	1.23	40.02	41.25	74.00	-32.75	peak
4	5561.667	2.17	38.99	41.16	74.00	-32.84	peak
5	6355.000	3.40	37.68	41.08	74.00	-32.92	peak
6	7206.000	5.88	37.35	43.23	74.00	-30.77	peak

Note: Level = Reading + Factor

Margin = Level – Limit

Factor= Antenna Factor + Cable Loss - Amplifier Factor



Power	: DC 3.3V	Pol/Phase	: Vertical
Test Mode	: Mode 2	Temperature	: 25 °C
Test Date	: Jul. 14, 2019	Humidity	: 52 %
Memo	: CH 00	Atmospheric Pressure	: 1010 hpa

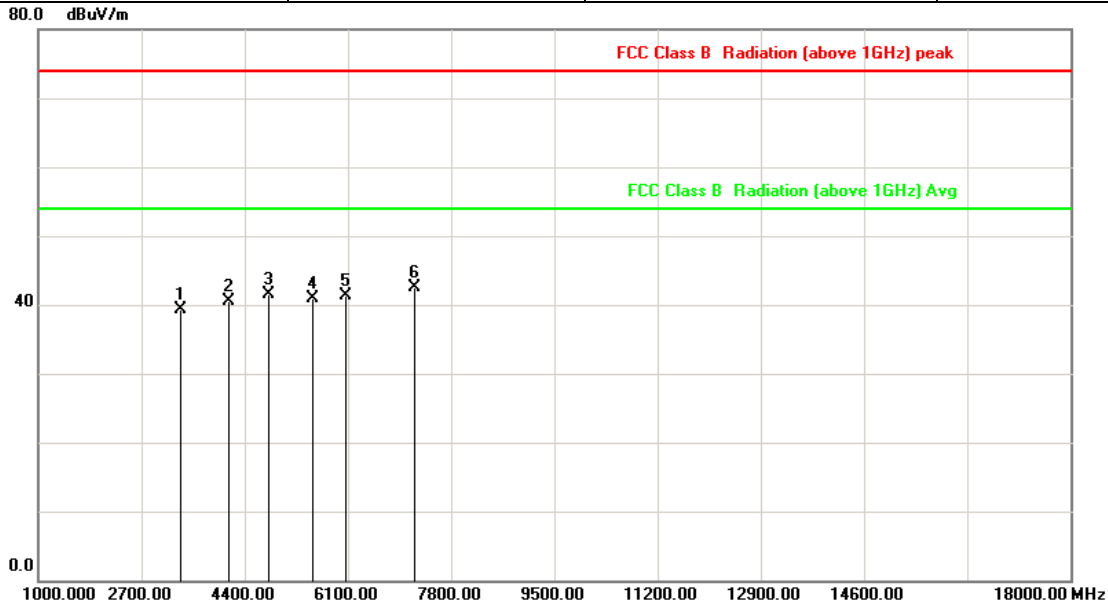

No.	Frequency (MHz)	Factor (dB/m)	Reading (dBuV)	Level (dBuV/m)	Limit (dBuV/m)	Margin (dB)	Detector
1	3351.667	-4.38	43.68	39.30	74.00	-34.70	peak
2	4145.000	-1.15	41.75	40.60	74.00	-33.40	peak
3	4804.000	1.23	40.29	41.52	74.00	-32.48	peak
4	5533.333	2.10	38.82	40.92	74.00	-33.08	peak
5	6071.667	3.29	37.98	41.27	74.00	-32.73	peak
6	7206.000	5.88	36.60	42.48	74.00	-31.52	peak

Note: Level = Reading + Factor
 Margin = Level – Limit
 Factor= Antenna Factor + Cable Loss - Amplifier Factor



Power	: DC 3.3V	Pol/Phase	: HORIZONTAL
Test Mode	: Mode 2	Temperature	: 25 °C
Test Date	: Jul. 14, 2019	Humidity	: 52 %
Memo	: CH 39	Atmospheric Pressure	: 1010 hpa

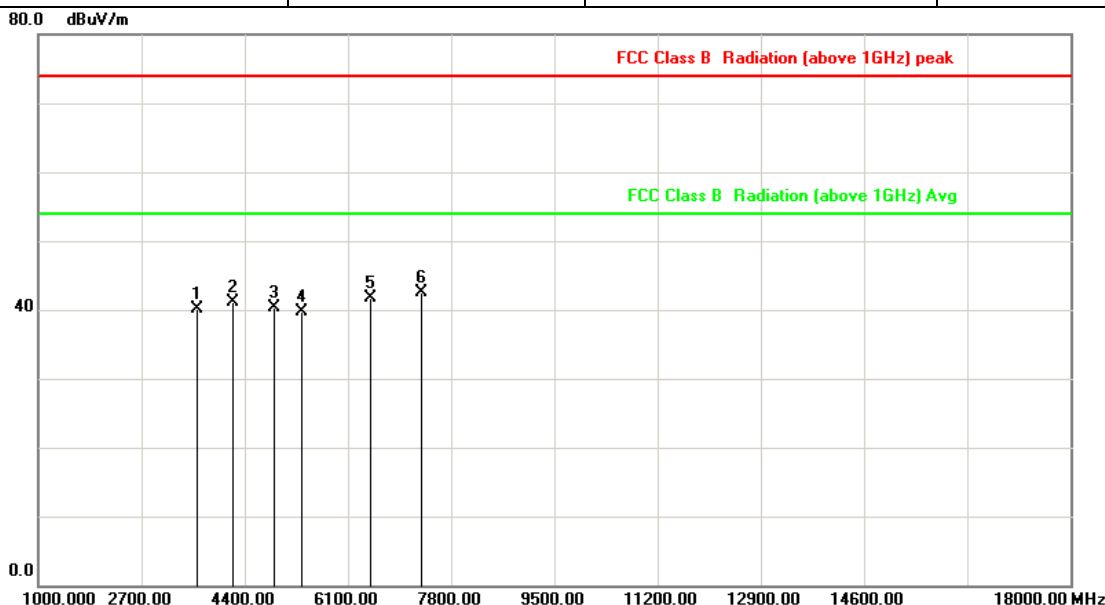

No.	Frequency (MHz)	Factor (dB/m)	Reading (dBuV)	Level (dBuV/m)	Limit (dBuV/m)	Margin (dB)	Detector
1	3606.667	-3.24	43.28	40.04	74.00	-33.96	peak
2	4201.667	-0.86	41.97	41.11	74.00	-32.89	peak
3	4882.000	1.38	38.92	40.30	74.00	-33.70	peak
4	5335.000	1.88	37.79	39.67	74.00	-34.33	peak
5	6468.333	3.45	38.23	41.68	74.00	-32.32	peak
6	7323.000	6.34	36.14	42.48	74.00	-31.52	peak

Note: Level = Reading + Factor

Margin = Level – Limit

Factor= Antenna Factor + Cable Loss - Amplifier Factor



Power	: DC 3.3V	Pol/Phase	: Vertical
Test Mode	: Mode 2	Temperature	: 25 °C
Test Date	: Jul. 14, 2019	Humidity	: 52 %
Memo	: CH 39	Atmospheric Pressure	: 1010 hpa

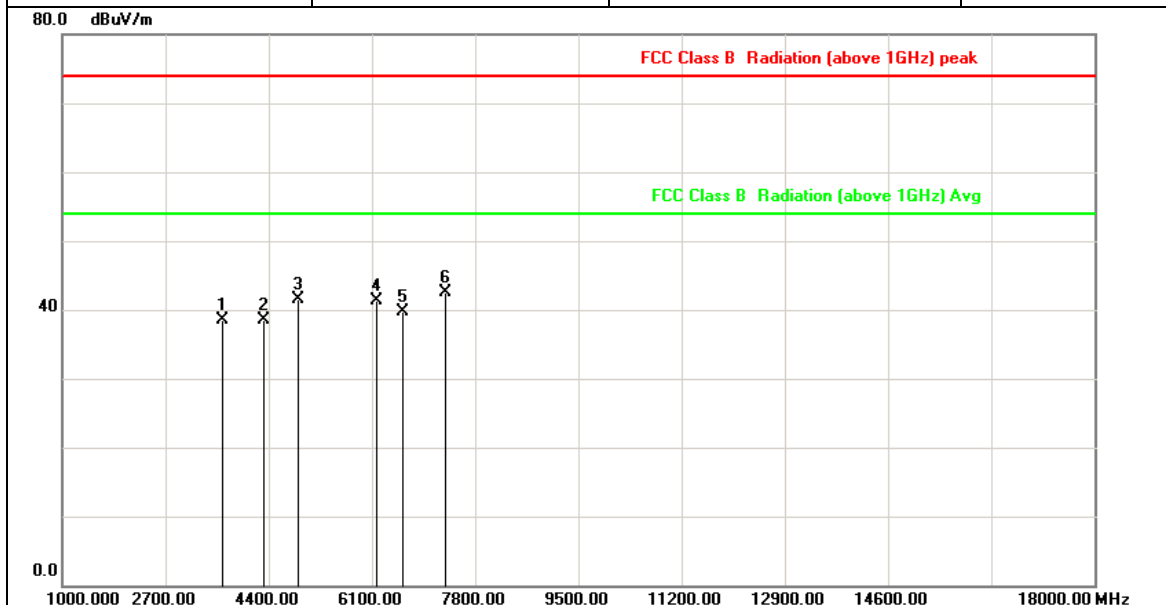

No.	Frequency (MHz)	Factor (dB/m)	Reading (dBuV)	Level (dBuV/m)	Limit (dBuV/m)	Margin (dB)	Detector
1	3635.000	-3.14	41.61	38.47	74.00	-35.53	peak
2	4315.000	-0.28	38.83	38.55	74.00	-35.45	peak
3	4882.000	1.38	40.20	41.58	74.00	-32.42	peak
4	6185.000	3.33	38.02	41.35	74.00	-32.65	peak
5	6610.000	3.82	35.80	39.62	74.00	-34.38	peak
6	7323.000	6.34	36.18	42.52	74.00	-31.48	peak

Note: Level = Reading + Factor
Margin = Level – Limit
Factor= Antenna Factor + Cable Loss - Amplifier Factor



Power	: DC 3.3V	Pol/Phase	: HORIZONTAL
Test Mode	: Mode 2	Temperature	: 25 °C
Test Date	: Jul. 14, 2019	Humidity	: 52 %
Memo	: CH 78	Atmospheric Pressure	: 1010 hpa

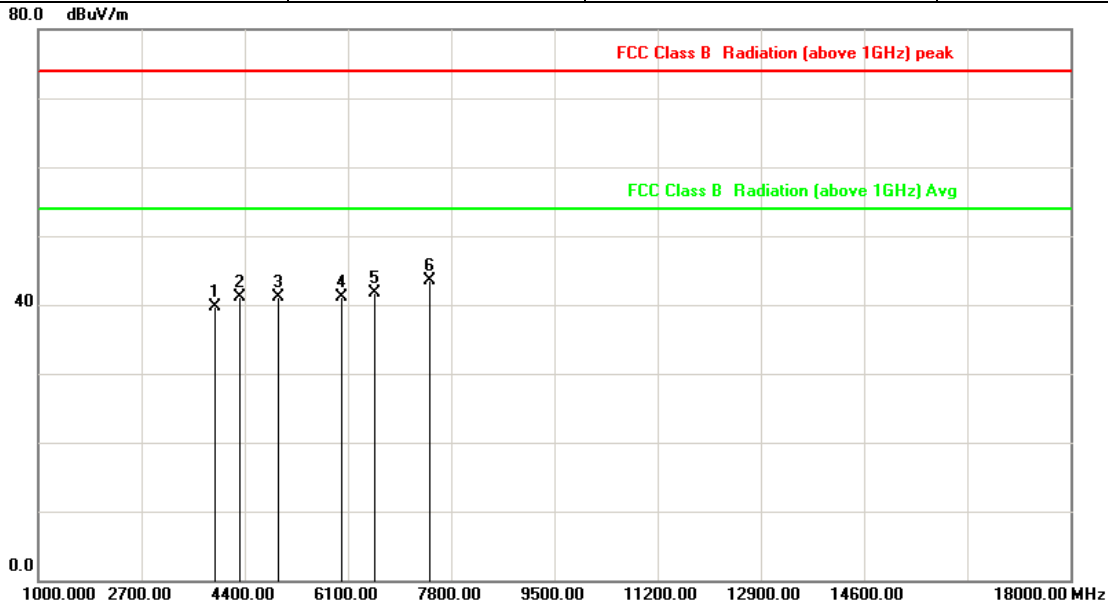

No.	Frequency (MHz)	Factor (dB/m)	Reading (dBuV)	Level (dBuV/m)	Limit (dBuV/m)	Margin (dB)	Detector
1	3918.333	-2.17	41.87	39.70	74.00	-34.30	peak
2	4315.000	-0.28	41.48	41.20	74.00	-32.80	peak
3	4960.000	1.52	39.57	41.09	74.00	-32.91	peak
4	5986.667	3.23	37.82	41.05	74.00	-32.95	peak
5	6553.333	3.63	38.12	41.75	74.00	-32.25	peak
6	7440.000	6.80	36.63	43.43	74.00	-30.57	peak

Note: Level = Reading + Factor

Margin = Level – Limit

Factor= Antenna Factor + Cable Loss - Amplifier Factor



Power	: DC 3.3V	Pol/Phase	: Vertical
Test Mode	: Mode 2	Temperature	: 25 °C
Test Date	: Jul. 14, 2019	Humidity	: 52 %
Memo	: CH 78	Atmospheric Pressure	: 1010 hpa

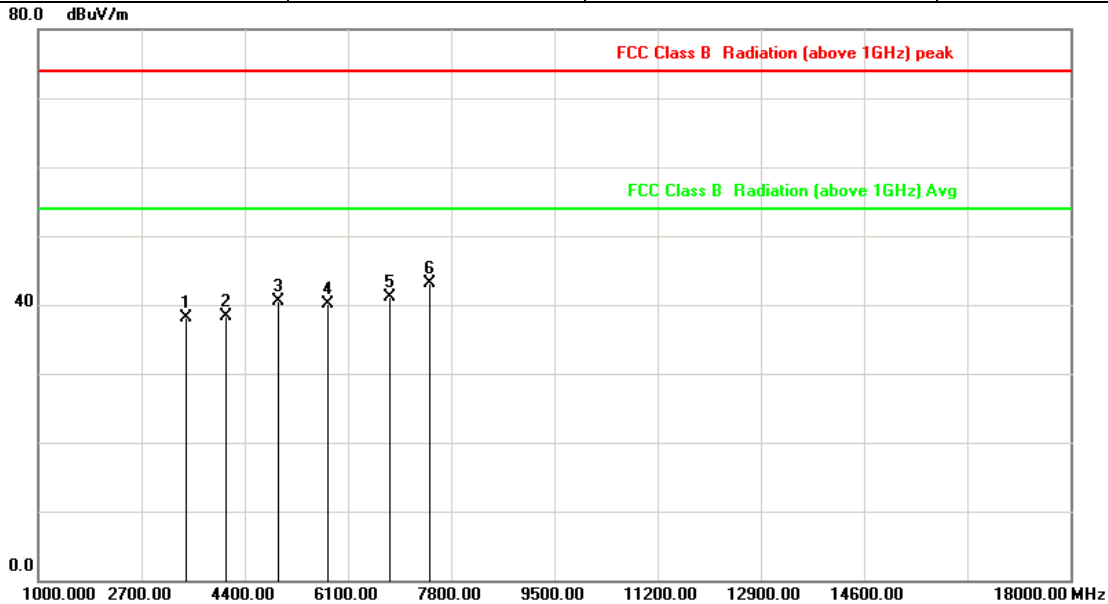

No.	Frequency (MHz)	Factor (dB/m)	Reading (dBuV)	Level (dBuV/m)	Limit (dBuV/m)	Margin (dB)	Detector
1	3436.667	-3.93	41.99	38.06	74.00	-35.94	peak
2	4088.333	-1.44	39.80	38.36	74.00	-35.64	peak
3	4960.000	1.52	38.97	40.49	74.00	-33.51	peak
4	5760.000	2.66	37.48	40.14	74.00	-33.86	peak
5	6780.000	4.37	36.75	41.12	74.00	-32.88	peak
6	7440.000	6.80	36.29	43.09	74.00	-30.91	peak

Note: Level = Reading + Factor
 Margin = Level – Limit
 Factor= Antenna Factor + Cable Loss - Amplifier Factor



Power	: DC 3.3V	Pol/Phase	: HORIZONTAL
Test Mode	: Mode 3	Temperature	: 25 °C
Test Date	: Jul. 14, 2019	Humidity	: 52 %
Memo	: CH 00	Atmospheric Pressure	: 1010 hpa

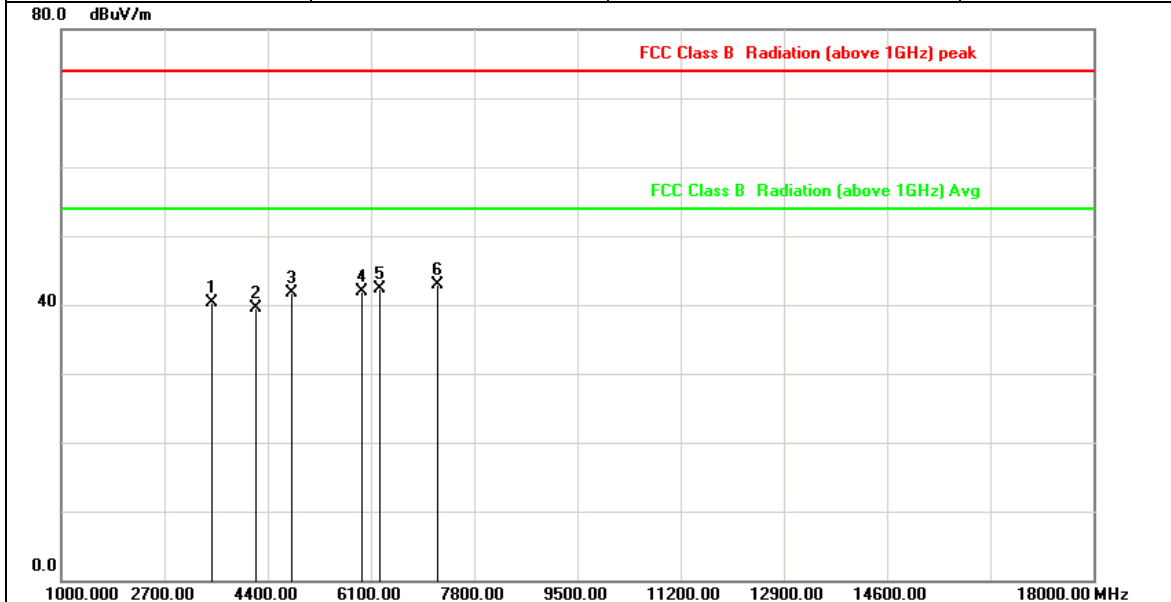

No.	Frequency (MHz)	Factor (dB/m)	Reading (dBuV)	Level (dBuV/m)	Limit (dBuV/m)	Margin (dB)	Detector
1	3493.333	-3.64	43.88	40.24	74.00	-33.76	peak
2	4201.667	-0.86	40.39	39.53	74.00	-34.47	peak
3	4804.000	1.23	40.49	41.72	74.00	-32.28	peak
4	5958.333	3.16	38.76	41.92	74.00	-32.08	peak
5	6241.667	3.36	38.96	42.32	74.00	-31.68	peak
6	7206.000	5.88	37.12	43.00	74.00	-31.00	peak

Note: Level = Reading + Factor
Margin = Level – Limit
Factor= Antenna Factor + Cable Loss - Amplifier Factor



Power	: DC 3.3V	Pol/Phase	: Vertical
Test Mode	: Mode 3	Temperature	: 25 °C
Test Date	: Jul. 14, 2019	Humidity	: 52 %
Memo	: CH 00	Atmospheric Pressure	: 1010 hpa

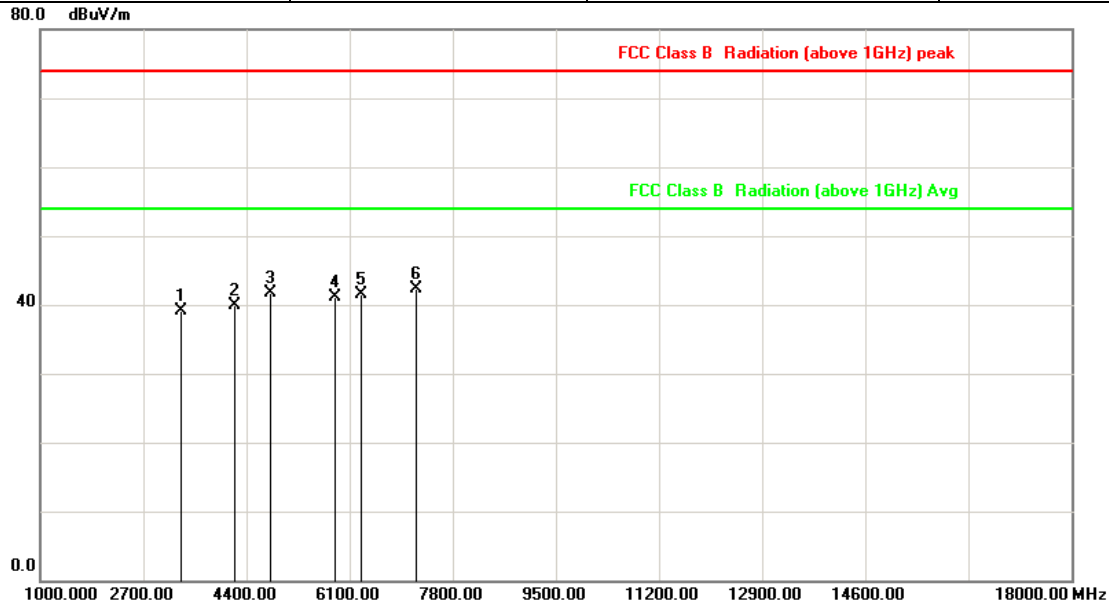

No.	Frequency (MHz)	Factor (dB/m)	Reading (dBuV)	Level (dBuV/m)	Limit (dBuV/m)	Margin (dB)	Detector
1	3323.333	-4.53	43.73	39.20	74.00	-34.80	peak
2	4201.667	-0.86	40.81	39.95	74.00	-34.05	peak
3	4804.000	1.23	40.57	41.80	74.00	-32.20	peak
4	5873.333	2.95	38.08	41.03	74.00	-32.97	peak
5	6298.333	3.38	38.16	41.54	74.00	-32.46	peak
6	7206.000	5.88	36.42	42.30	74.00	-31.70	peak

Note: Level = Reading + Factor
 Margin = Level – Limit
 Factor= Antenna Factor + Cable Loss - Amplifier Factor



Power	: DC 3.3V	Pol/Phase	: HORIZONTAL
Test Mode	: Mode 3	Temperature	: 25 °C
Test Date	: Jul. 14, 2019	Humidity	: 52 %
Memo	: CH 39	Atmospheric Pressure	: 1010 hpa

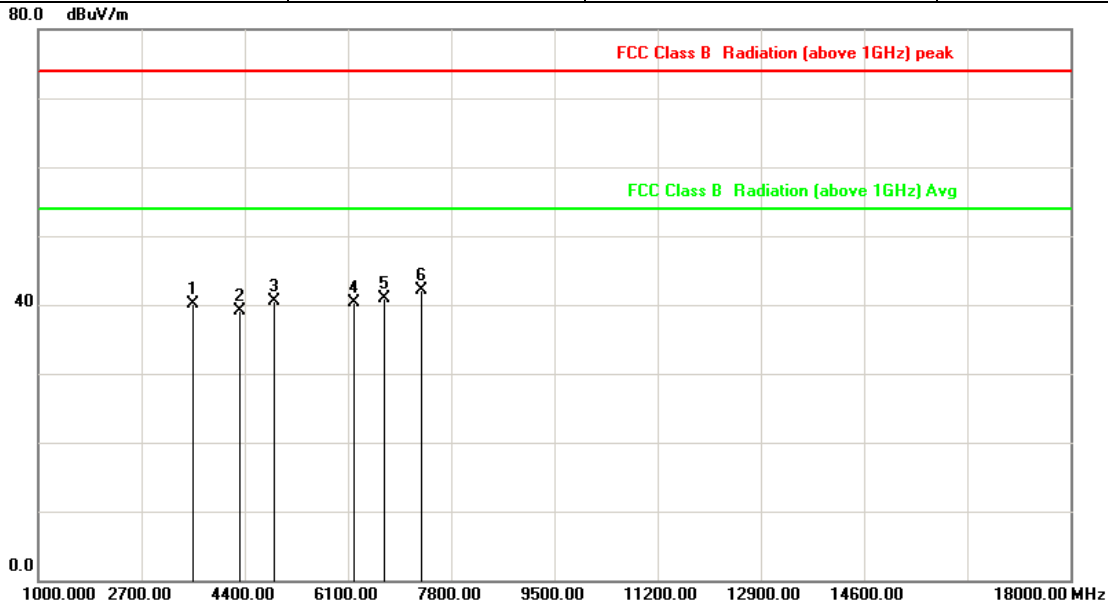

No.	Frequency (MHz)	Factor (dB/m)	Reading (dBuV)	Level (dBuV/m)	Limit (dBuV/m)	Margin (dB)	Detector
1	3550.000	-3.43	43.59	40.16	74.00	-33.84	peak
2	4315.000	-0.28	39.32	39.04	74.00	-34.96	peak
3	4882.000	1.38	39.22	40.60	74.00	-33.40	peak
4	6213.333	3.35	37.00	40.35	74.00	-33.65	peak
5	6695.000	4.09	36.88	40.97	74.00	-33.03	peak
6	7323.000	6.34	35.81	42.15	74.00	-31.85	peak

Note: Level = Reading + Factor

Margin = Level – Limit

Factor= Antenna Factor + Cable Loss - Amplifier Factor



Power	: DC 3.3V	Pol/Phase	: Vertical
Test Mode	: Mode 3	Temperature	: 25 °C
Test Date	: Jul. 14, 2019	Humidity	: 52 %
Memo	: CH 39	Atmospheric Pressure	: 1010 hpa

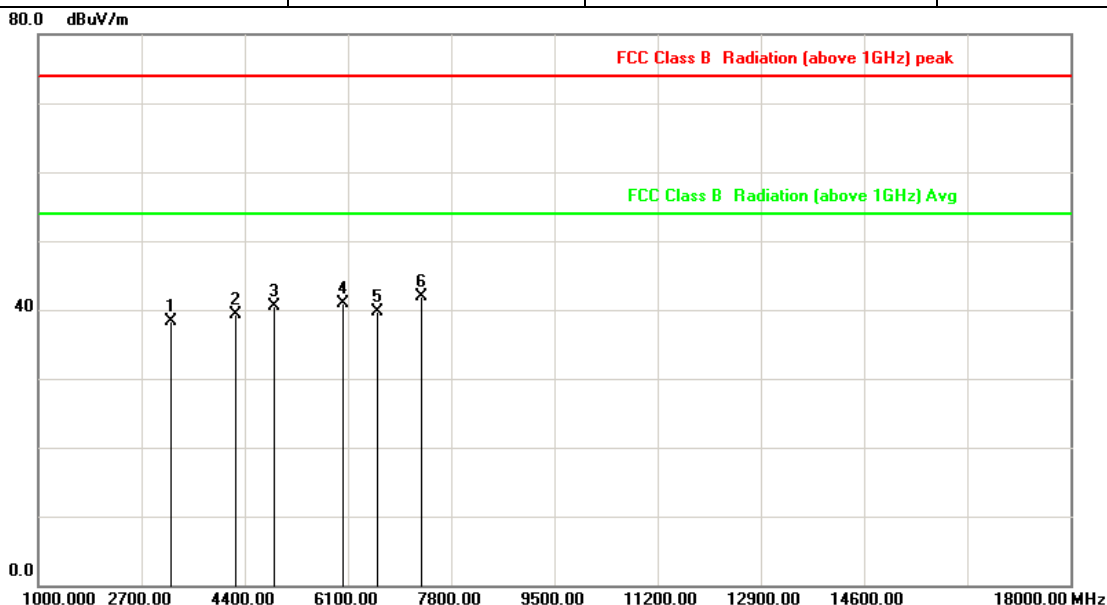

No.	Frequency (MHz)	Factor (dB/m)	Reading (dBuV)	Level (dBuV/m)	Limit (dBuV/m)	Margin (dB)	Detector
1	3181.667	-5.27	43.51	38.24	74.00	-35.76	peak
2	4258.333	-0.57	39.96	39.39	74.00	-34.61	peak
3	4882.000	1.38	39.18	40.56	74.00	-33.44	peak
4	6015.000	3.27	37.57	40.84	74.00	-33.16	peak
5	6581.667	3.72	36.07	39.79	74.00	-34.21	peak
6	7323.000	6.34	35.62	41.96	74.00	-32.04	peak

Note: Level = Reading + Factor
 Margin = Level – Limit
 Factor= Antenna Factor + Cable Loss - Amplifier Factor



Power	: DC 3.3V	Pol/Phase	: HORIZONTAL
Test Mode	: Mode 3	Temperature	: 25 °C
Test Date	: Jul. 14, 2019	Humidity	: 52 %
Memo	: CH 78	Atmospheric Pressure	: 1010 hpa

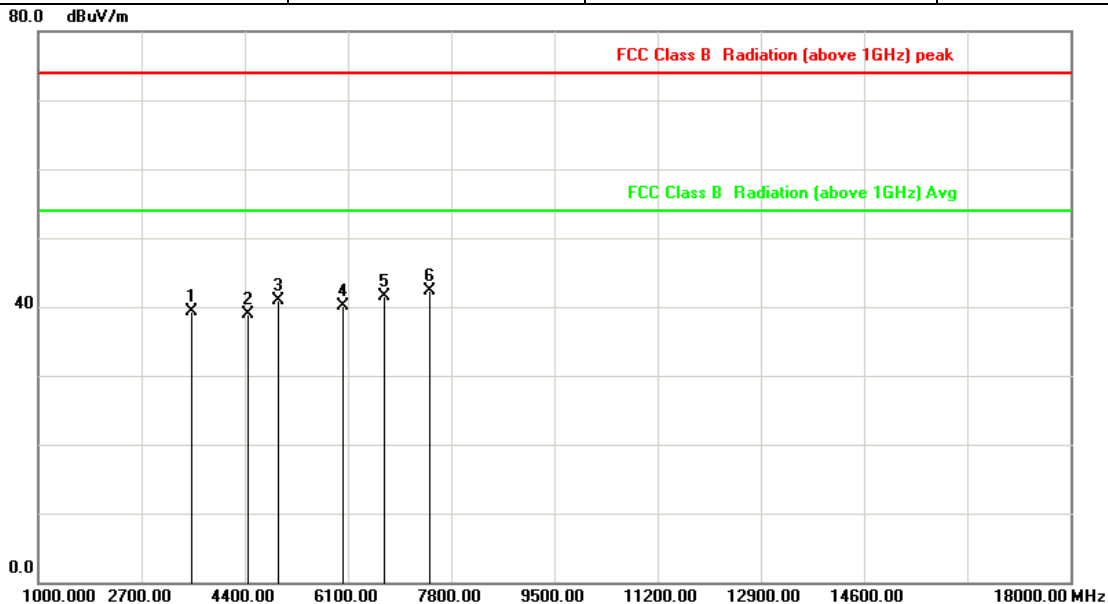

No.	Frequency (MHz)	Factor (dB/m)	Reading (dBuV)	Level (dBuV/m)	Limit (dBuV/m)	Margin (dB)	Detector
1	3521.667	-3.53	42.86	39.33	74.00	-34.67	peak
2	4456.667	0.44	38.37	38.81	74.00	-35.19	peak
3	4960.000	1.52	39.45	40.97	74.00	-33.03	peak
4	6015.000	3.27	36.90	40.17	74.00	-33.83	peak
5	6695.000	4.09	37.38	41.47	74.00	-32.53	peak
6	7440.000	6.80	35.43	42.23	74.00	-31.77	peak

Note: Level = Reading + Factor
 Margin = Level – Limit
 Factor= Antenna Factor + Cable Loss - Amplifier Factor



Power	: DC 3.3V	Pol/Phase	: Vertical
Test Mode	: Mode 3	Temperature	: 25 °C
Test Date	: Jul. 14, 2019	Humidity	: 52 %
Memo	: CH 78	Atmospheric Pressure	: 1010 hpa

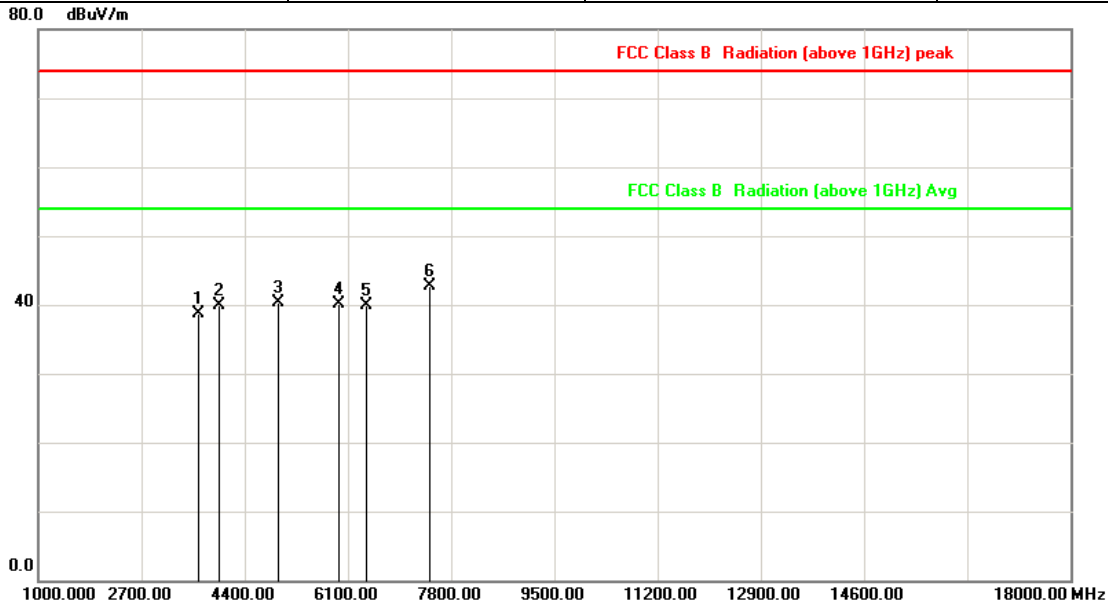

No.	Frequency (MHz)	Factor (dB/m)	Reading (dBuV)	Level (dBuV/m)	Limit (dBuV/m)	Margin (dB)	Detector
1	3635.000	-3.14	41.78	38.64	74.00	-35.36	peak
2	3975.000	-1.98	41.79	39.81	74.00	-34.19	peak
3	4960.000	1.52	38.76	40.28	74.00	-33.72	peak
4	5958.333	3.16	36.95	40.11	74.00	-33.89	peak
5	6411.667	3.42	36.58	40.00	74.00	-34.00	peak
6	7440.000	6.80	35.87	42.67	74.00	-31.33	peak

Note: Level = Reading + Factor
 Margin = Level – Limit
 Factor= Antenna Factor + Cable Loss - Amplifier Factor



6. 20dB Bandwidth Measurement

6.1 Test Limit

Frequency hopping systems shall have hopping channel carrier frequencies separated by a minimum of 25 kHz or the 20 dB bandwidth of the hopping channel, whichever is greater. Alternatively, frequency hopping systems operating in the 2400–2483.5 MHz band may have hopping channel carrier frequencies that are separated by 25 kHz or two-thirds of the 20 dB bandwidth of the hopping channel, whichever is greater, provided the systems operate with an output power no greater than 125mW.

6.2 Test Standard

ANSI C63.10-2013- Section 7.8.7

6.3 Test Setup

1. Set RBW \geq 1% of the 20dB bandwidth
2. VBW \geq 3 \times RBW
3. Span = approximately 2 to 3 times the 20dB bandwidth, centered on a hopping channel
4. Detector = Peak
5. Trace mode = max hold
6. Sweep = auto couple
7. Allow the trace to stabilize
8. Measure the maximum width of the emission that is constrained by the frequencies associated with the two outermost amplitude points (upper and lower frequencies) that are attenuated by 20dB relative to the maximum level measured in the fundamental emission

6.4 Test Setup Layout

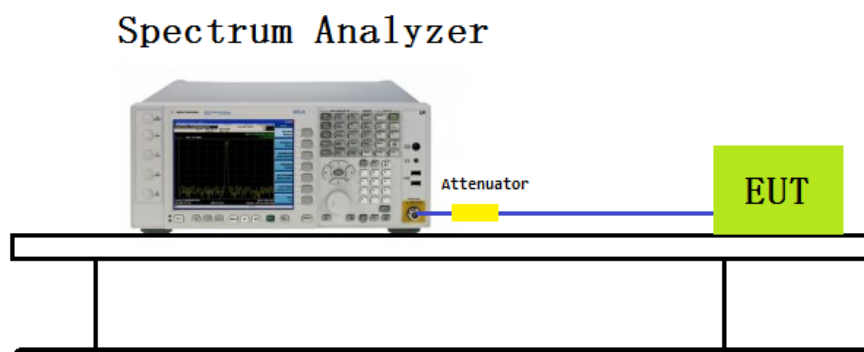



6.5 Test Result and Data

Test Item	Occupied Bandwidth
Test Mode	Mode 1: Transmitter DH5

Channel No.	Frequency(MHz)	20dB Bandwidth(kHz)
00	2402	956.5
39	2441	955.3
78	2480	955.2

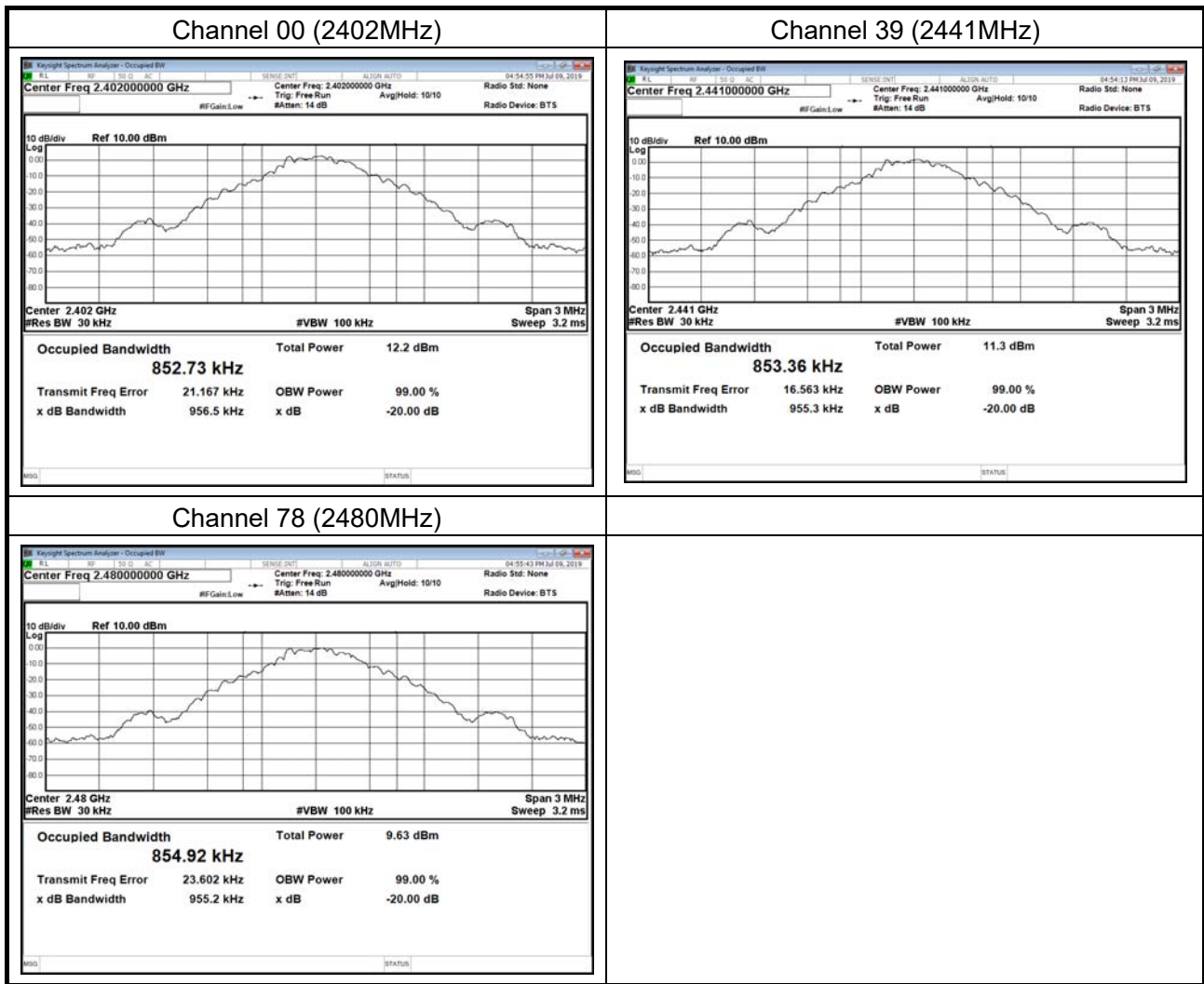



Test Item	Occupied Bandwidth
Test Mode	Mode 2: Transmitter 2DH5

Channel No.	Frequency(MHz)	20dB Bandwidth(kHz)
00	2402	1278
39	2441	1277
78	2480	1279

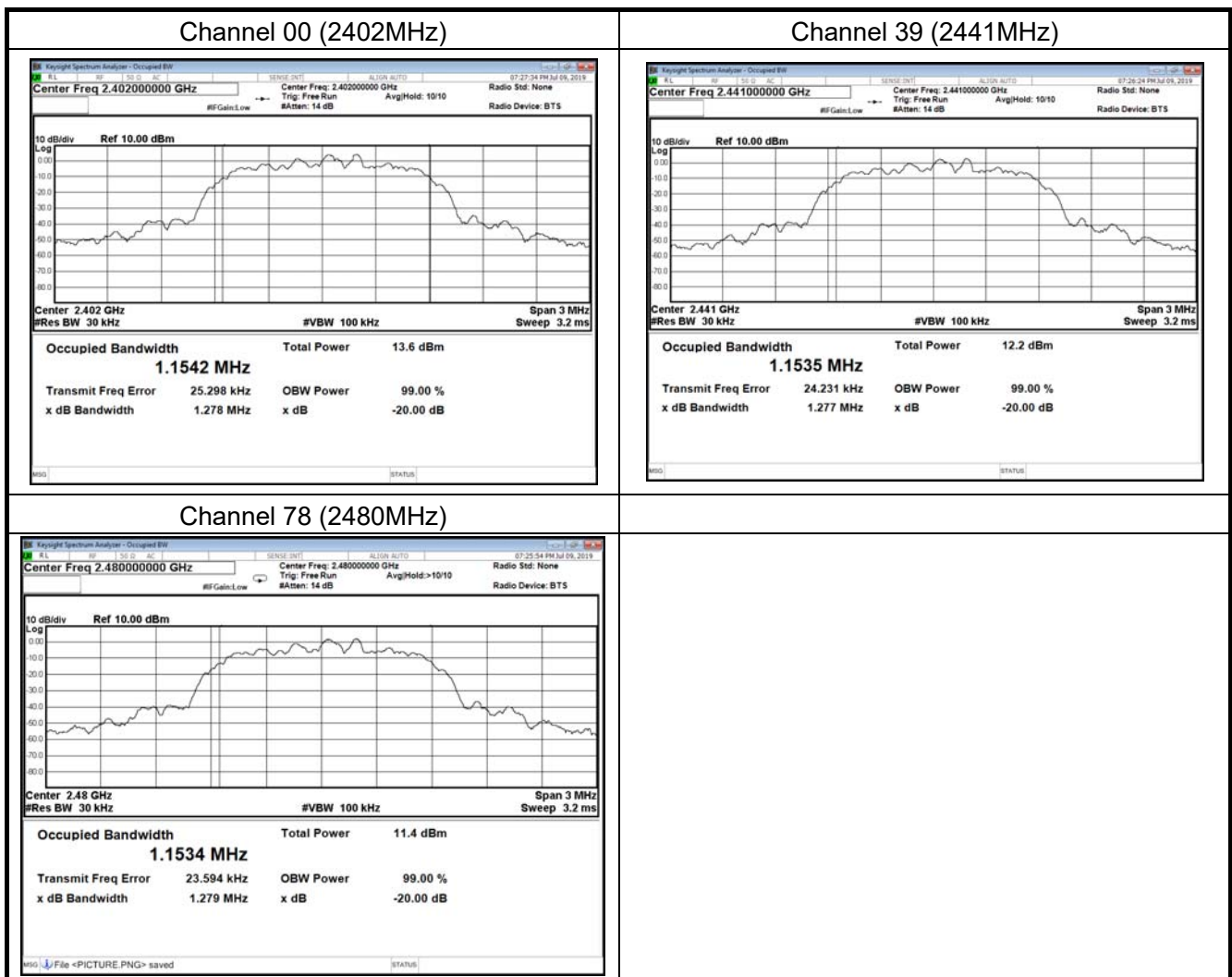



Test Item	Occupied Bandwidth
Test Mode	Mode 3: Transmitter 3DH5

Channel No.	Frequency(MHz)	20dB Bandwidth(kHz)
00	2402	1292
39	2441	1292
78	2480	1292

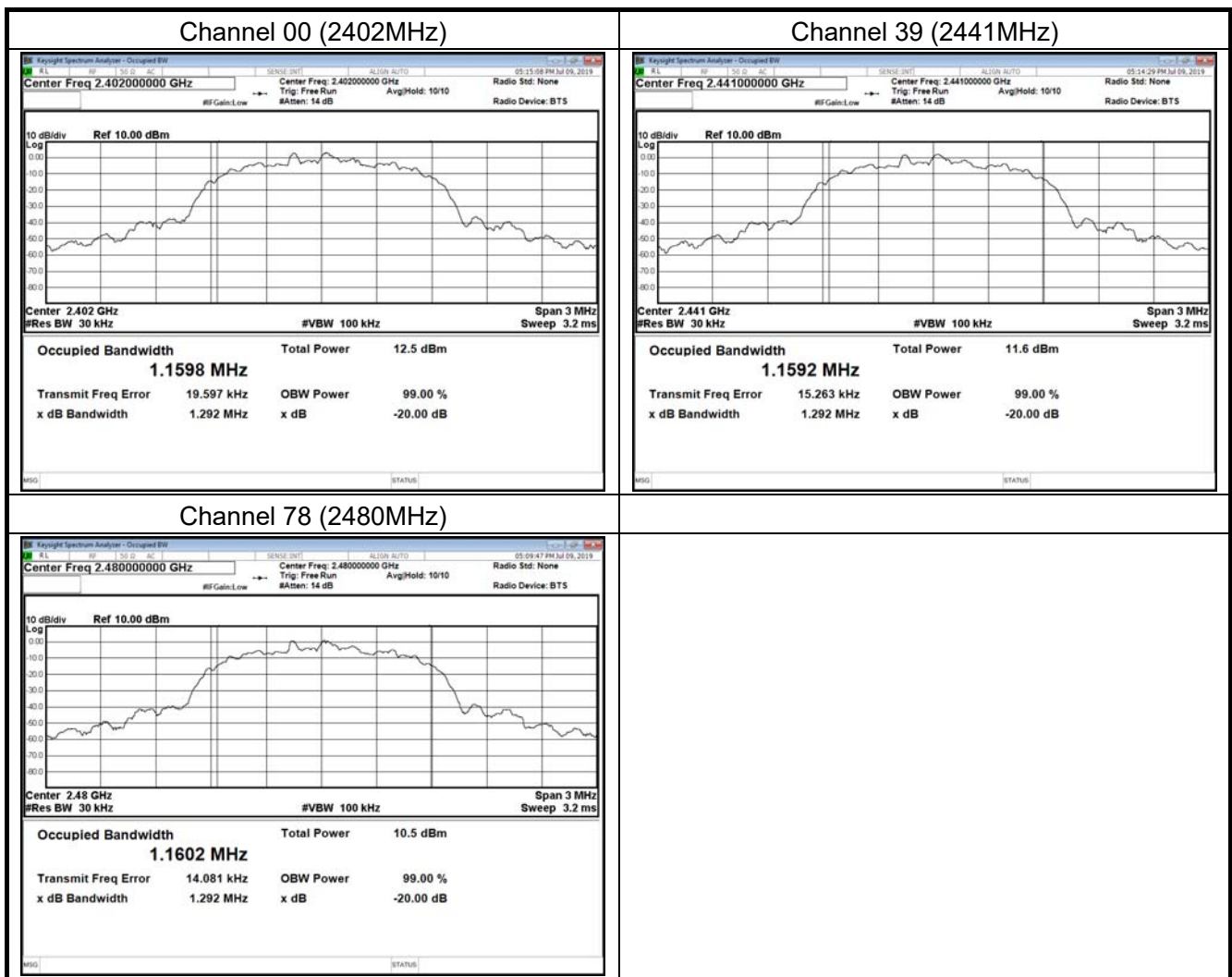



7. Channel Carrier Frequencies Separation Measurement

7.1 Test Limit

Frequency hopping systems shall have hopping channel carrier frequencies separated by a minimum of 25 kHz or the 20 dB bandwidth of the hopping channel, whichever is greater.

7.2 Test Standard

ANSI C63.10-2013- Section 7.8.2

7.3 Test Setup

The EUT shall have its hopping function enabled. Use the following spectrum analyzer settings:

- Span: Wide enough to capture the peaks of two adjacent channels.
- RBW: Start with the RBW set to approximately 30% of the channel spacing; adjust as necessary to best identify the center of each individual channel.
- Video (or average) bandwidth (VBW) \geq RBW
- Sweep: Auto
- Detector function: Peak
- Trace: Max hold
- Allow the trace to stabilize

Use the marker-delta function to determine the separation between the peaks of the adjacent channels. Compliance of an EUT with the appropriate regulatory limit shall be determined. A plot of the data shall be included in the test report.

7.4 Test Setup Layout

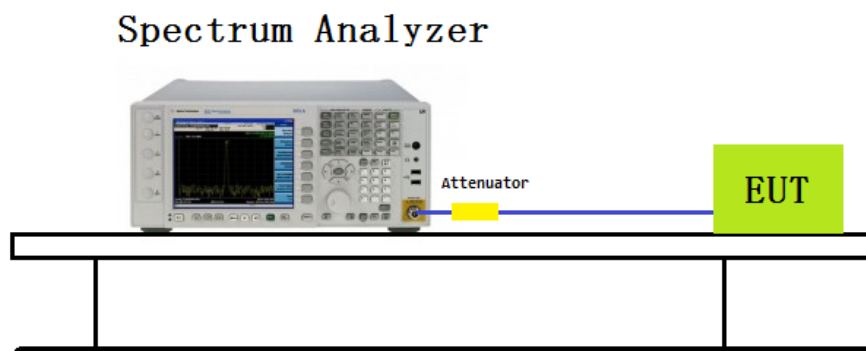



7.5 Test Result and Data

Test Item	:	Channel Carrier Frequency Separation
Test Mode	:	Mode 1: Transmitter DH5

Channel No.	Frequency (MHz)	Carrier Frequency Separation (kHz)	Limit (kHz)	Result
00	2402	1000	>25 kHz or 2/3 of 20 dB BW	Pass
39	2441	1000	>25 kHz or 2/3 of 20 dB BW	Pass
78	2480	1000	>25 kHz or 2/3 of 20 dB BW	Pass

Test Item	:	Carrier Frequency Separation
Test Mode	:	Mode 2: Transmitter 2DH5

Channel No.	Frequency (MHz)	Carrier Frequency Separation(kHz)	Limit (kHz)	Result
00	2402	1000	>25 kHz or 2/3 of 20 dB BW	Pass
39	2441	1000	>25 kHz or 2/3 of 20 dB BW	Pass
78	2480	1000	>25 kHz or 2/3 of 20 dB BW	Pass

Test Item	:	Carrier Frequency Separation
Test Mode	:	Mode 3: Transmitter 3DH5

Channel No.	Frequency (MHz)	Carrier Frequency Separation(kHz)	Limit (kHz)	Result
00	2402	1000	>25 kHz or 2/3 of 20 dB BW	Pass
39	2441	1000	>25 kHz or 2/3 of 20 dB BW	Pass
78	2480	1000	>25 kHz or 2/3 of 20 dB BW	Pass



Modulation Standard: GFSK (1Mbps)

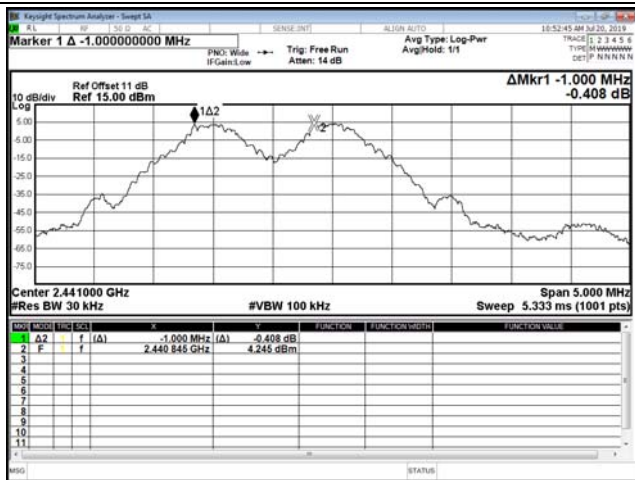

Modulation Standard: π/4 DQPSK (2Mbps)

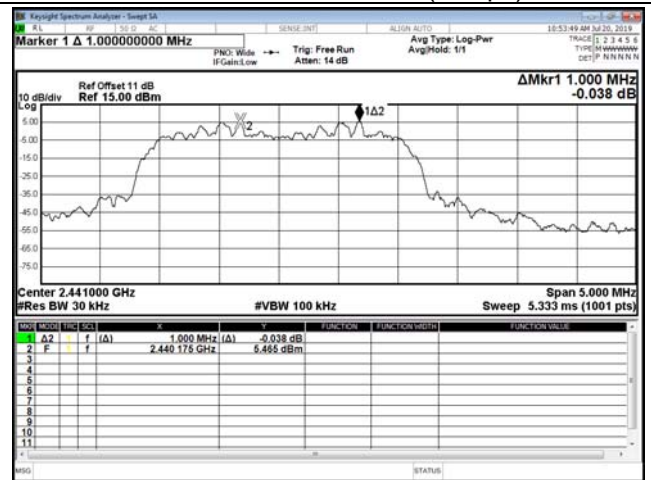

Modulation Standard: 8DPSK (3Mbps)
Channel: 78

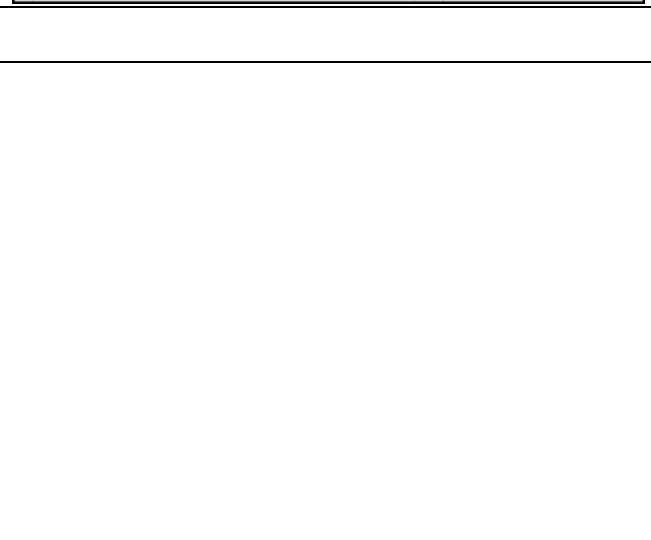
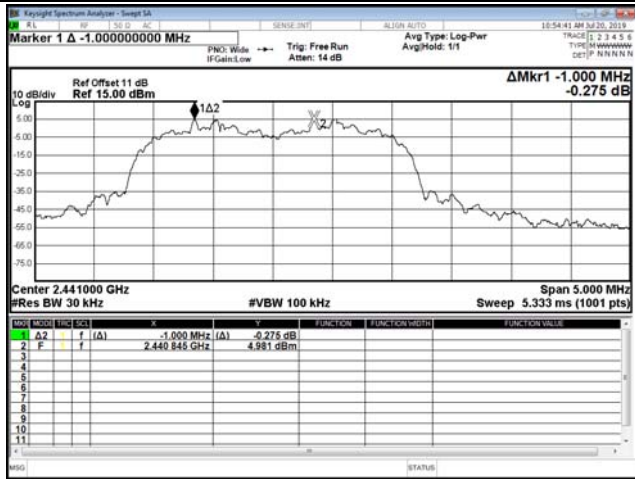



8. Dwell Time Measurement

8.1 Test Limit

The average time of occupancy on any channel shall not be greater than 0.4 seconds within a period of 0.4 seconds multiplied by the number of hopping channels employed.

8.2 Test Standard

ANSI C63.10-2013- Section 7.8.3

8.3 Test Setup

The EUT shall have its hopping function enabled. Use the following spectrum analyzer settings:

- Span: Zero span, centered on a hopping channel.
- RBW shall be \leq channel spacing and where possible RBW should be set $\gg 1 / T$, where T is the expected dwell time per channel.
- Sweep: As necessary to capture the entire dwell time per hopping channel; where possible use a video trigger and trigger delay so that the transmitted signal starts a little to the right of the start of the plot. The trigger level might need slight adjustment to prevent triggering when the system hops on an adjacent channel; a second plot might be needed with a longer sweep time to show two successive hops on a channel.
- Detector function: Peak
- Trace: Max hold

8.4 Test Setup Layout

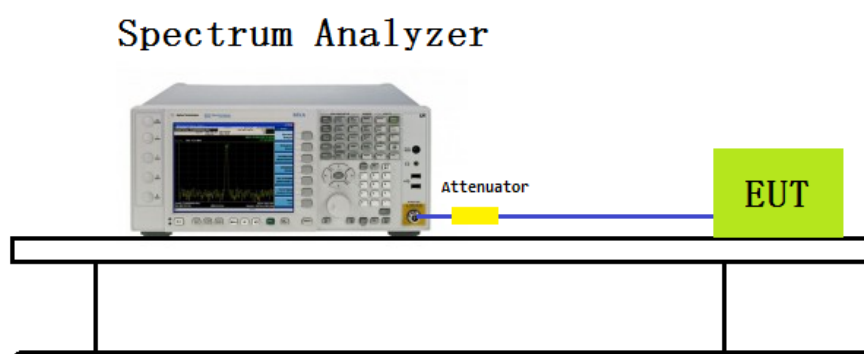



8.5 Test Result and Data

Test Date : Jul. 19, 2019 Temperature : 22C
 Atmospheric pressure : 1017 hPa Humidity : 60 %
 Test Period = 0.4 (second/ channel) x 79 Channel = 31.6 sec

Modulation Standard: GFSK(1Mbps)

DH 1

Pulse Time (ms)	Total of Dwell (ms)	Period Time (s)	Limit (ms)	Result
0.384	122.88	31.6	400	PASS

Remark: Total of Dwell = pulse Time * (1600/2) / 79 * Period Time

DH 3

Pulse Time (ms)	Total of Dwell (ms)	Period Time (s)	Limit (ms)	Result
1.64	262.40	31.6	400	PASS

Remark: Total of Dwell = pulse Time * (1600/4) / 79 * Period Time

DH 5

Pulse Time (ms)	Total of Dwell (ms)	Period Time (s)	Limit (ms)	Result
2.885	307.73	31.6	400	PASS

Remark: Total of Dwell = pulse Time * (1600/6) / 79 * Period Time

Modulation Standard: $\pi/4$ DQPSK(2Mbps)

DH 1

Pulse Time (ms)	Total of Dwell (ms)	Period Time (s)	Limit (ms)	Result
0.393	125.76	31.6	400	PASS

Remark: Total of Dwell = pulse Time * (1600/2) / 79 * Period Time

DH 3

Pulse Time (ms)	Total of Dwell (ms)	Period Time (s)	Limit (ms)	Result
1.64	262.40	31.6	400	PASS

Remark: Total of Dwell = pulse Time * (1600/4) / 79 * Period Time

DH 5

Pulse Time (ms)	Total of Dwell (ms)	Period Time (s)	Limit (ms)	Result
2.89	308.27	31.6	400	PASS

Remark: Total of Dwell = pulse Time * (1600/6) / 79 * Period Time



Modulation Standard: 8DPSK(3Mbps)

DH 1

Pulse Time (ms)	Total of Dwell (ms)	Period Time (s)	Limit (ms)	Result
0.39	124.8	31.6	400	PASS

Remark: Total of Dwell = pulse Time * (1600/2) / 79 * Period Time

DH 3

Pulse Time (ms)	Total of Dwell (ms)	Period Time (s)	Limit (ms)	Result
1.645	263.20	31.6	400	PASS

Remark: Total of Dwell = pulse Time * (1600/4) / 79 * Period Time

DH 5

Pulse Time (ms)	Total of Dwell (ms)	Period Time (s)	Limit (ms)	Result
2.895	308.80	31.6	400	PASS

Remark: Total of Dwell = pulse Time * (1600/6) / 79 * Period Time



Modulation Standard: GFSK (1Mbps)
DH1

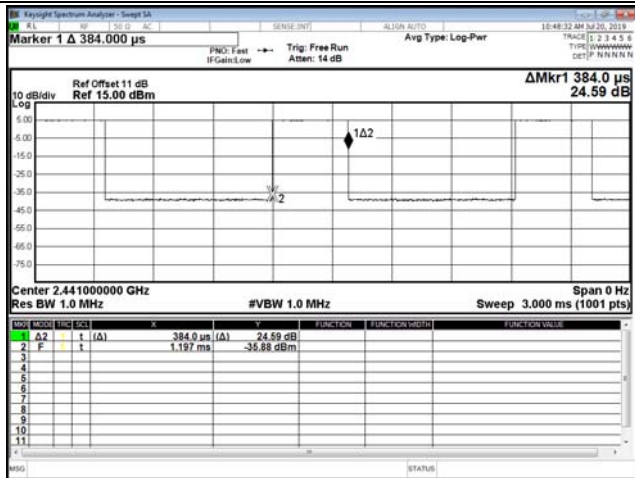

Modulation Standard: GFSK (1Mbps)
DH3

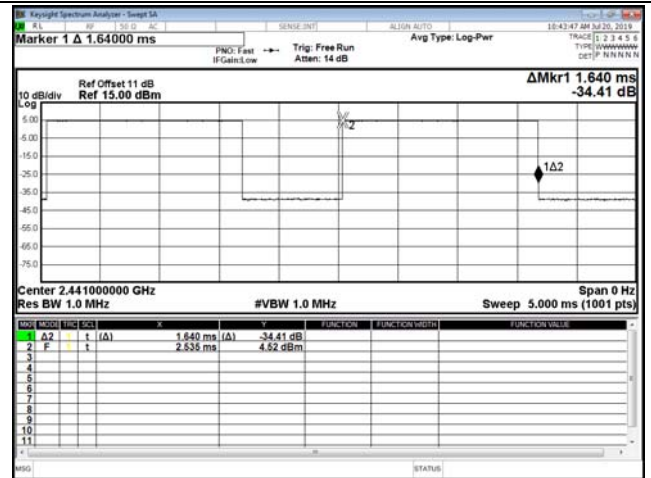

Modulation Standard: GFSK (1Mbps)
DH5

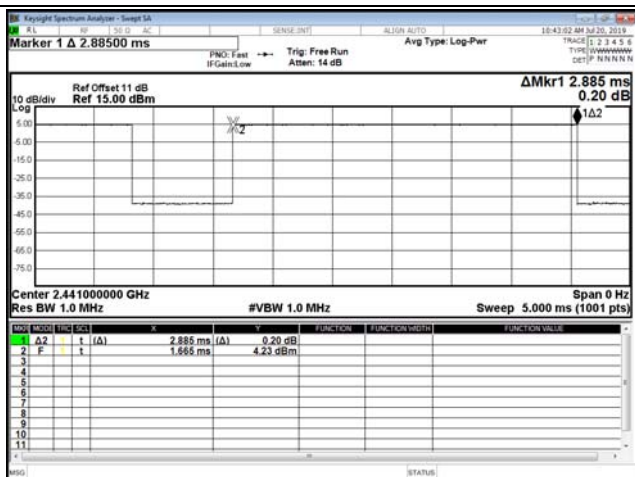

Modulation Standard: π/4 DQPSK (2Mbps)
DH1

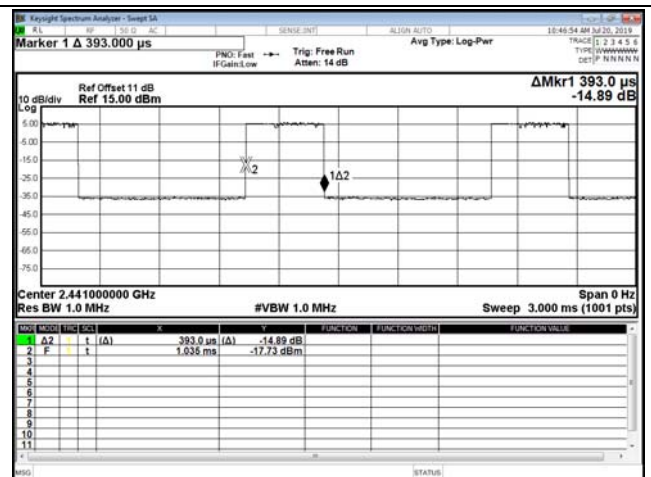

Modulation Standard: π/4 DQPSK (2Mbps)
DH3

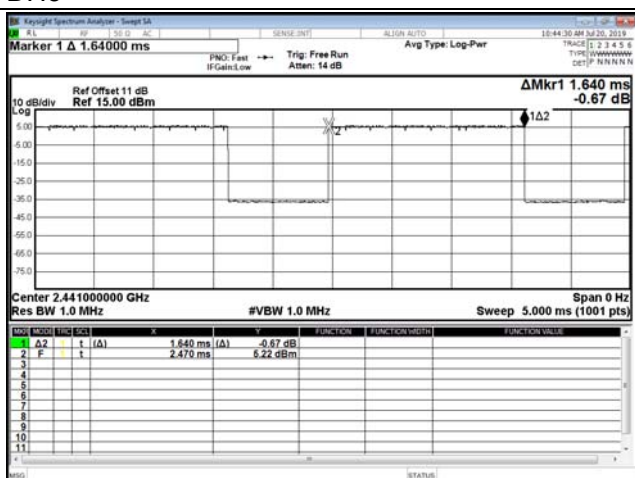

Modulation Standard: π/4 DQPSK (2Mbps)
DH5

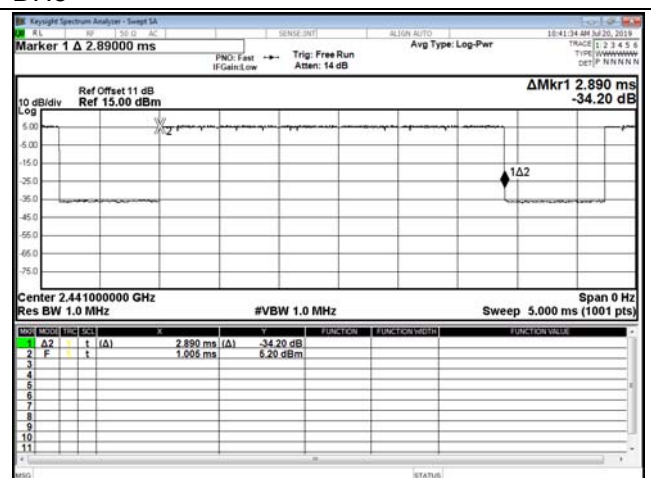



Modulation Standard: 8DPSK (3Mbps)
DH1

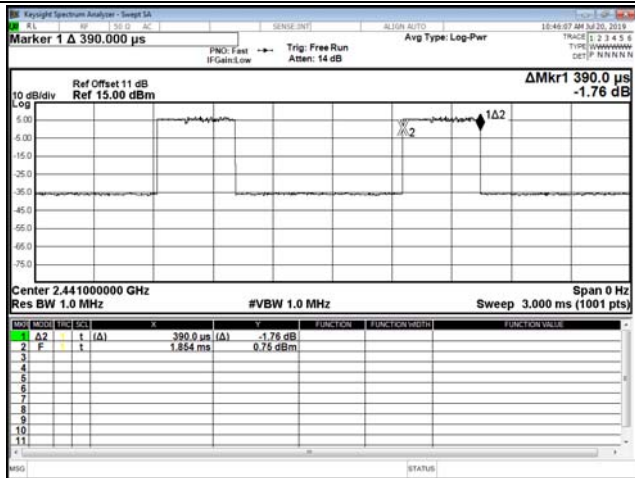

Modulation Standard: 8DPSK (3Mbps)
DH3

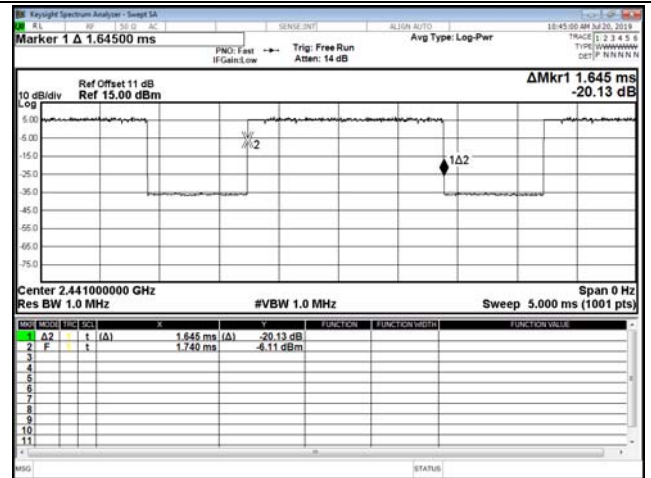

Modulation Standard: 8DPSK (3Mbps)
DH5

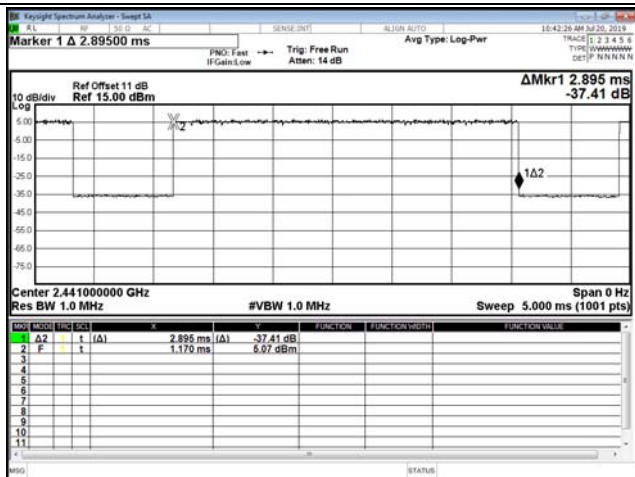



Test Period = 0.4 (second/ channel) x 20 Channel = 8 sec

Modulation Type	Frequency (MHz)	Length of transmission time (ms)	Number of transmission in a 8 (20 Hopping*0.4)	Dwell Time (ms)	Limit (ms)
AFH (DH1)	2402-2421	0.393	160	62.88	400
AFH (DH3)	2402-2421	1.65	80	132.00	400
AFH (DH5)	2402-2421	2.895	53.33	154.39	400

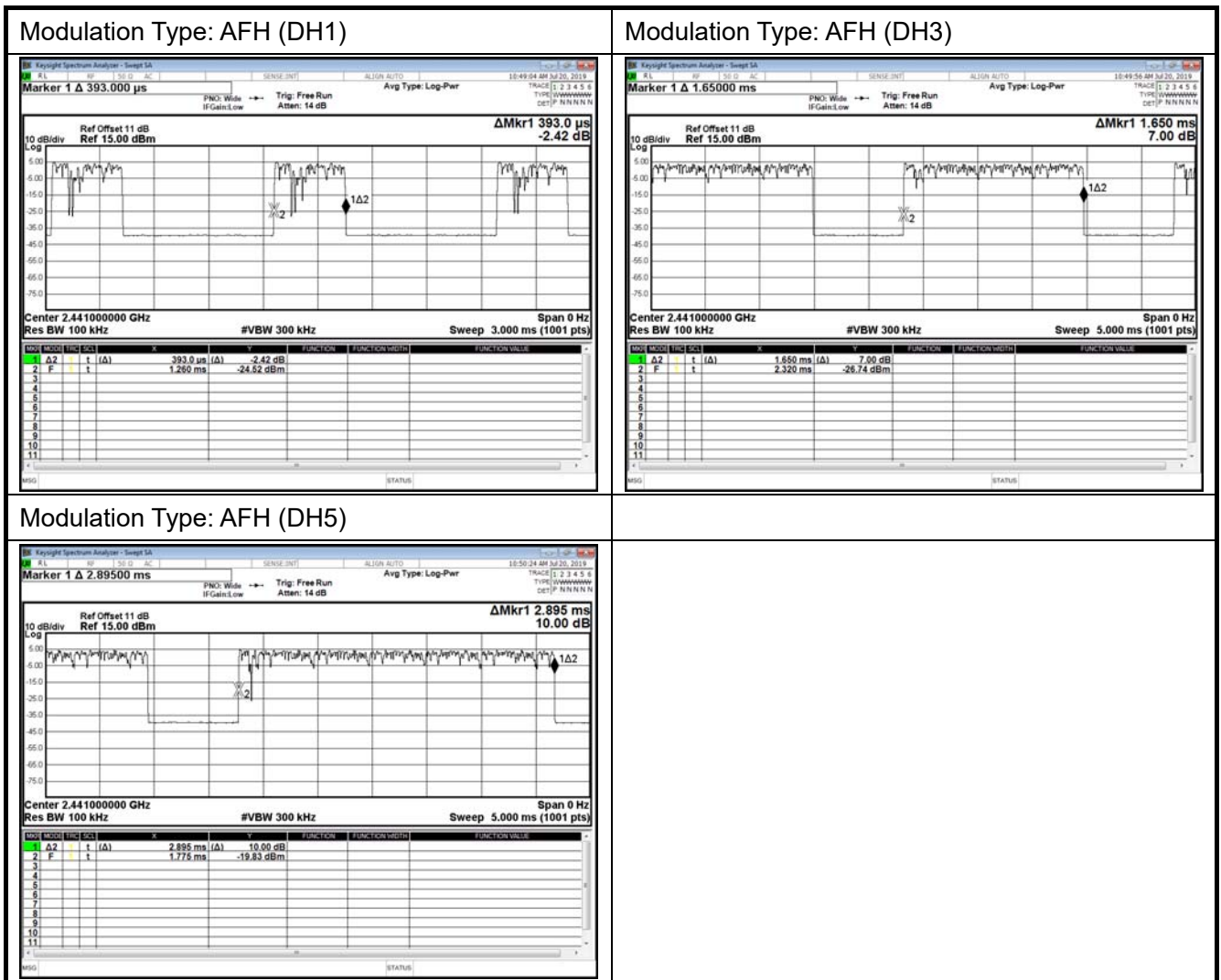



9. Number of Hopping Channels Measurement

9.1 Test Limit

Frequency hopping systems in the 2400 ~ 2483.5 MHz band shall use at least 15 channels.

9.2 Test Standard

ANSI C63.10-2013- Section 7.8.3

9.3 Test Setup

The EUT shall have its hopping function enabled. Use the following spectrum analyzer settings:

- Span: The frequency band of operation. Depending on the number of channels the device supports, it may be necessary to divide the frequency range of operation across multiple spans, to allow the individual channels to be clearly seen.
- RBW: To identify clearly the individual channels, set the RBW to less than 30% of the channel spacing or the 20 dB bandwidth, whichever is smaller.
- VBW \geq RBW
- Sweep: Auto
- Detector function: Peak
- Trace: Max hold
- Allow the trace to stabilize

9.4 Test Setup Layout

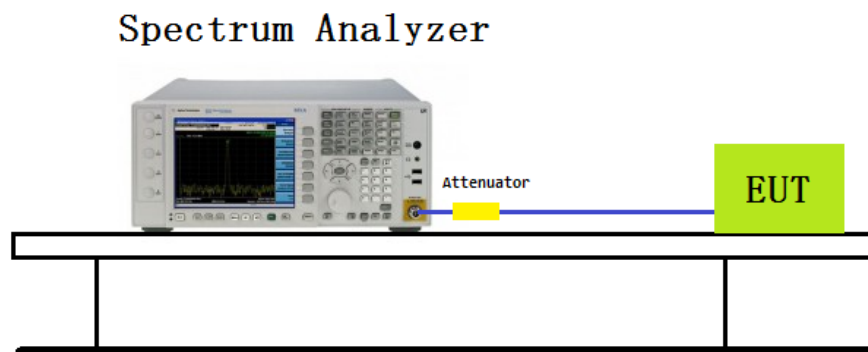



9.5 Test Result and Data

Test Item	:	Number of Hopping Frequencies
-----------	---	-------------------------------

Test Mode	Frequency Band (MHz)	Number of Hopping Frequencies	Limit	Result
Mode 1: Transmitter DH5	2400 - 2483.5	79	>15	Pass
Mode 2: Transmitter DH5	2400 - 2483.5	79	>15	Pass
Mode 3: Transmitter DH5	2400 - 2483.5	79	>15	Pass





10. Peak Output Power Measurement

10.1 Test Limit

The Maximum Peak Output Power Measurement is 125mW (20.97dBm).

10.2 Test Standard

ANSI C63.10-2013- Section 7.8.5

10.3 Test Setup

Spectrum analyzer method

a) Use the following spectrum analyzer settings:

- 1) Span: Approximately five times the 20 dB bandwidth, centered on a hopping channel.
 - 2) RBW > 20 dB bandwidth of the emission being measured.
 - 3) VBW \geq RBW.
 - 4) Sweep: Auto.
 - 5) Detector function: Peak.
 - 6) Trace: Max hold.
- b) Allow trace to stabilize.
- c) Use the marker-to-peak function to set the marker to the peak of the emission.
- d) The indicated level is the peak output power, after any corrections for external attenuators and cables.
- e) A plot of the test results and setup description shall be included in the test report

Peak power meter method

The antenna port (RF output) of the EUT was connected to the input (RF input) of a power meter. Power was read directly from the meter and cable loss connection was added to the reading to obtain power at the EUT antenna terminal. The EUT Output Power was set to maximum to produce the worse case test result.



10.4 Test Setup Layout

Spectrum Analyzer

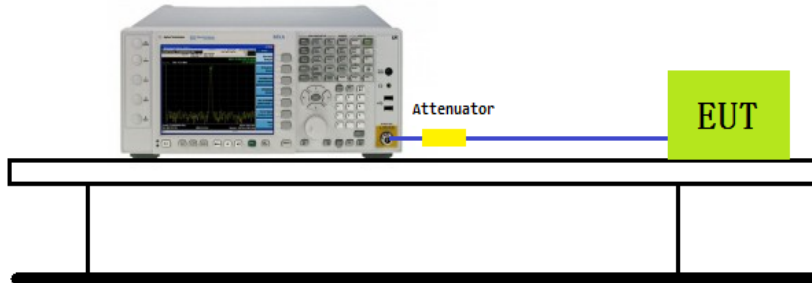



10.5 Test Result and Data

Test Item	:	Peak Output Power
Test Mode	:	Mode 1: Transmitter DH5

Channel No.	Frequency (MHz)	Measurement Power Output (dBm)	Limit (dBm)	Result
0	2402	5.36	20.97	Pass
39	2441	4.30	20.97	Pass
78	2480	2.30	20.97	Pass

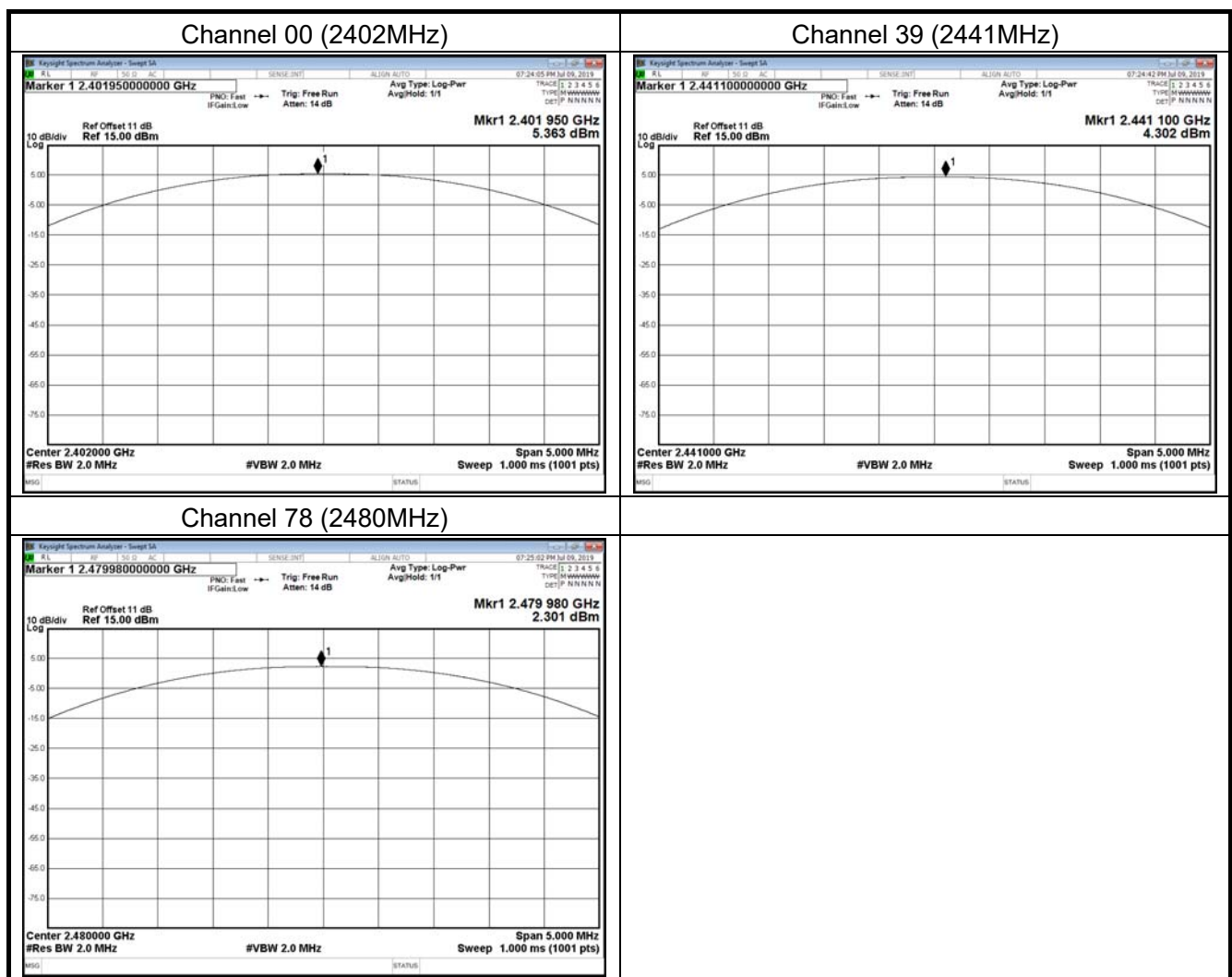



Test Item	:	Peak Output Power
Test Mode	:	Mode 2: Transmitter 2DH5

Channel No.	Frequency (MHz)	Measurement Power Output (dBm)	Limit (dBm)	Result
0	2402	7.80	20.97	Pass
39	2441	6.36	20.97	Pass
78	2480	5.32	20.97	Pass

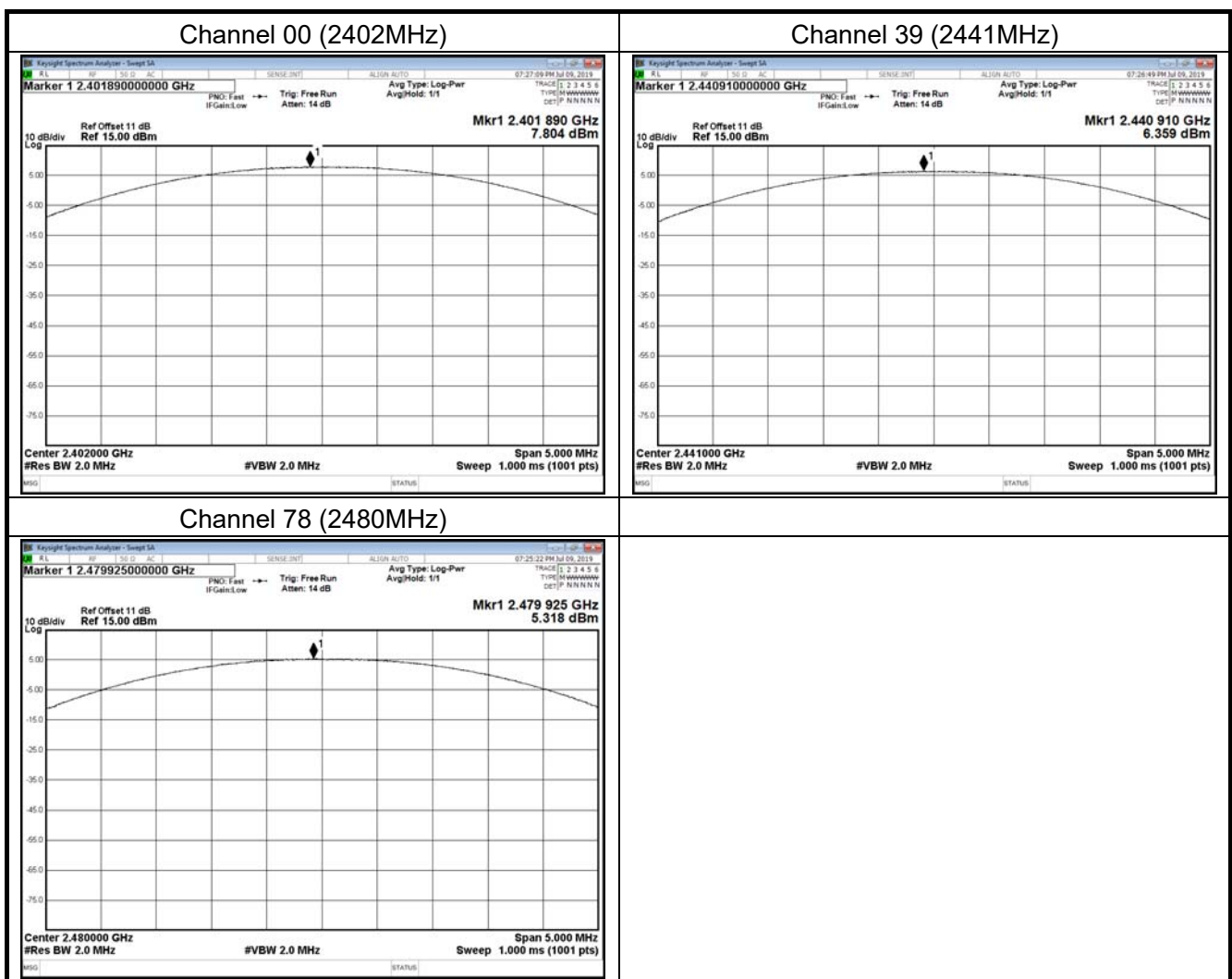



Test Item	:	Peak Output Power
Test Mode	:	Mode 3: Transmitter 3DH5

Channel No.	Frequency (MHz)	Measurement Power Output (dBm)	Limit (dBm)	Result
0	2402	7.90	20.97	Pass
39	2441	6.72	20.97	Pass
78	2480	5.53	20.97	Pass

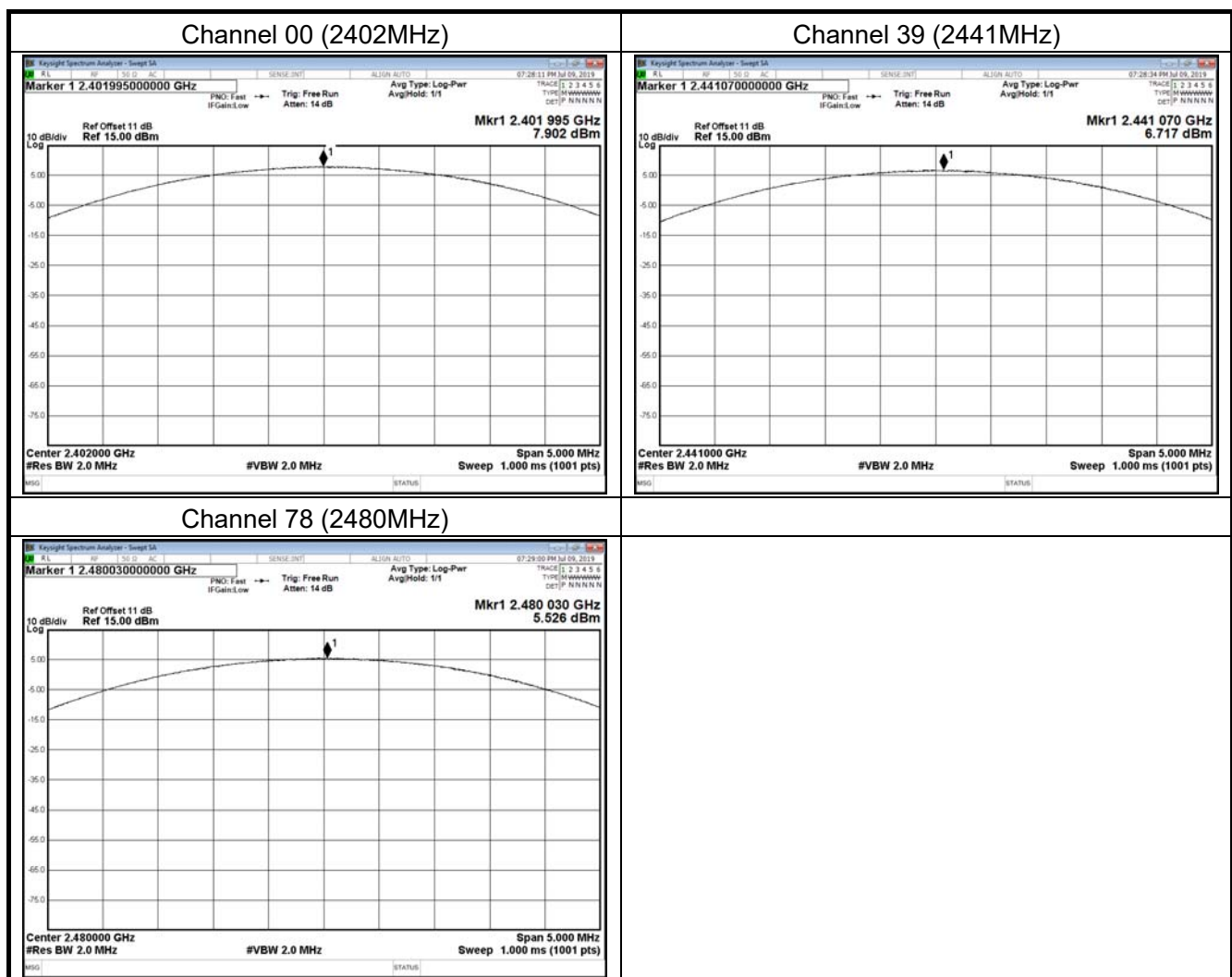



11. Conducted Spurious Emissions Measurement

11.1 Limit

In any 100 kHz bandwidth outside the frequency band in which the spread spectrum or digitally modulated intentional radiator is operating, the radio frequency power that is produced by the intentional radiator shall be at least 20 dB below that in the 100 kHz bandwidth within the band that contains the highest level of the desired power, based on either an RF conducted or a radiated measurement, provided the transmitter demonstrates compliance with the peak conducted or a radiated measurement, provided the transmitter demonstrates compliance with the peak conducted power limits. If the transmitter complies with the conducted power limits based on the use of RMS averaging over a time interval, the attenuation required under this paragraph shall be 30 dB instead of 20 dB. Attenuation below the general limits specified in Section 15.209(a) of FCC part 15 is not required.



11.2 Test Procedure

According to ANSI C63.10: 2013.

Use the following spectrum analyzer settings:

Span = wide enough to capture the peak level of the in-band emission and all spurious emissions (e.g., harmonics) from the lowest frequency generated in the EUT up through the 10th harmonic. Typically, several plots are required to cover this entire span.

RBW = 100 kHz

VBW \geq RBW

Sweep = auto

Detector function = peak

Trace = max hold

Allow the trace to stabilize. Set the marker on the peak of any spurious emission recorded. The level displayed must comply with the limit specified in this section.

11.3 Test Setup

Spectrum Analyzer

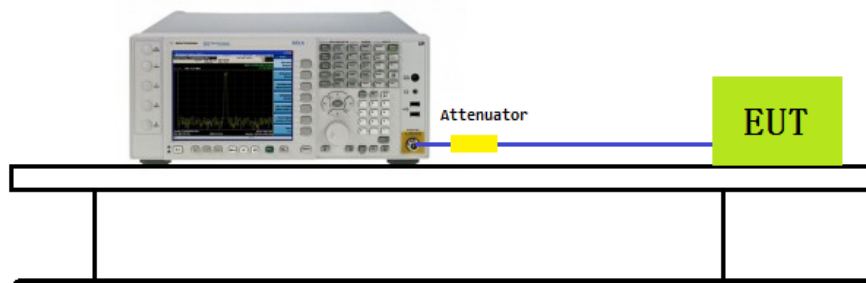



11.4 Test Result

Single test

Modulation Standard: GFSK (1Mbps)

Channel: 00

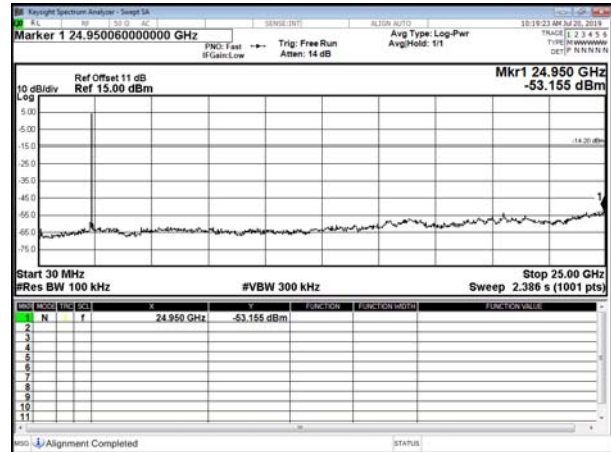
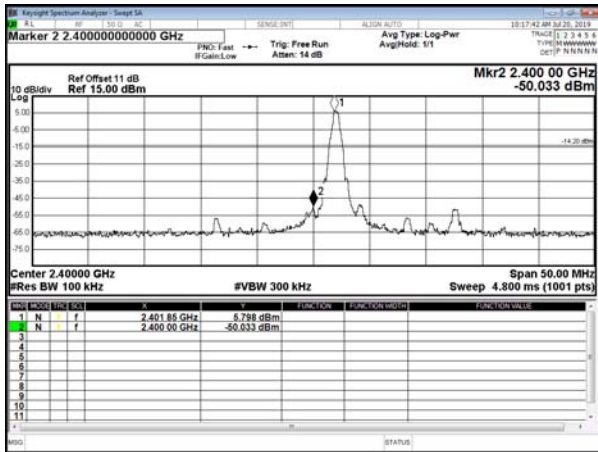

Modulation Standard: GFSK (1Mbps)

Channel: 39

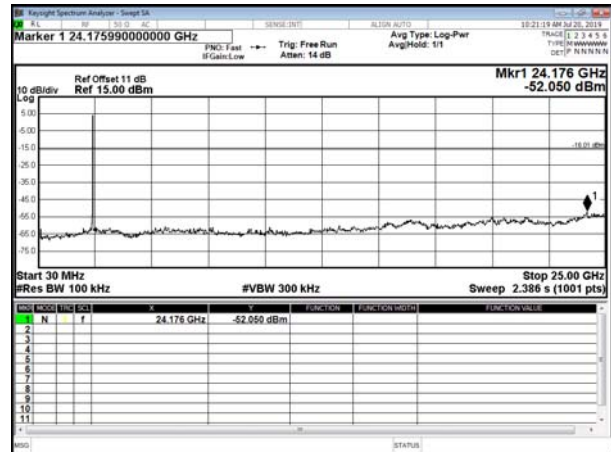
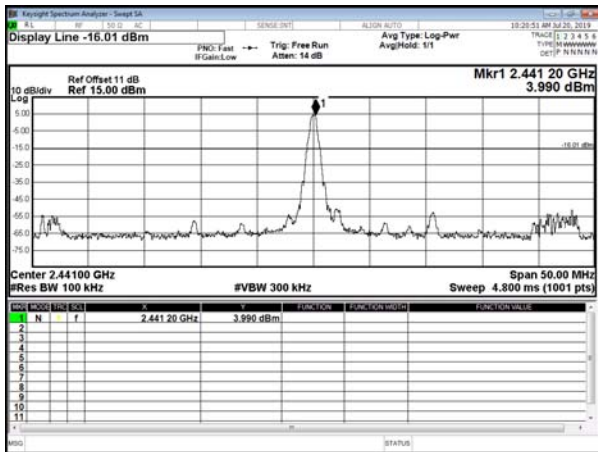

Modulation Standard: GFSK (1Mbps)

Channel: 78

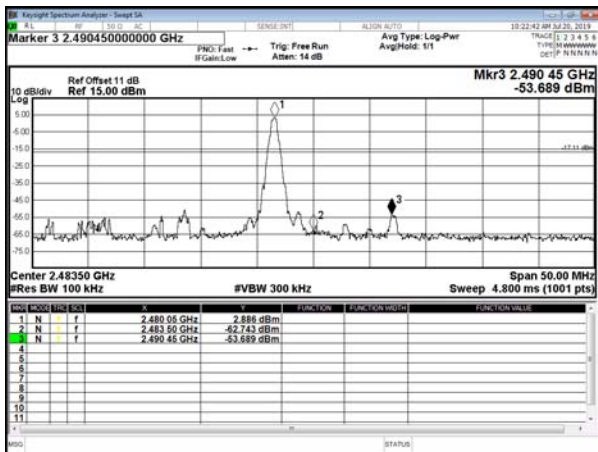



Modulation Standard: $\pi/4$ DQPSK (2Mbps)

Channel: 00

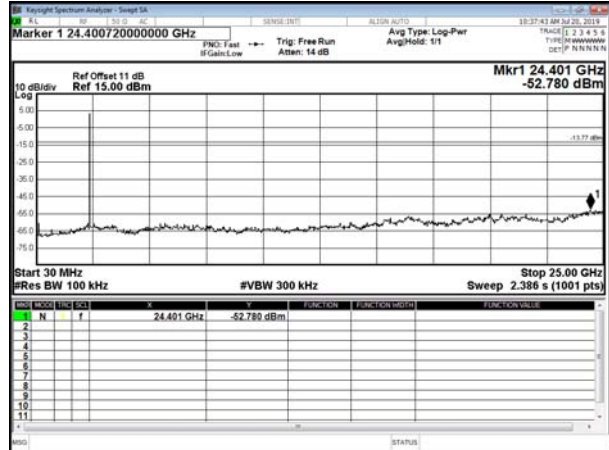
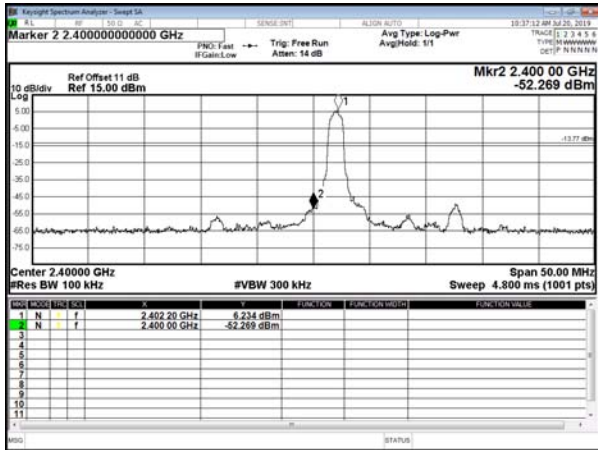

Modulation Standard: $\pi/4$ DQPSK (2Mbps)

Channel: 39

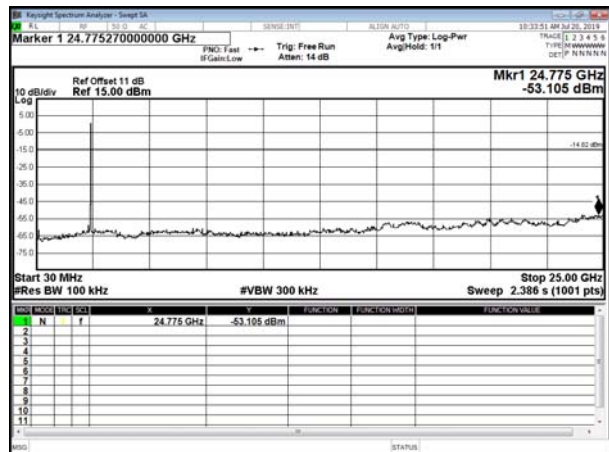
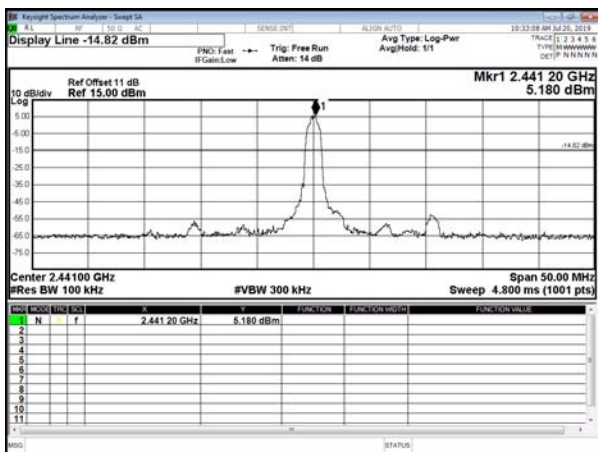

Modulation Standard: $\pi/4$ DQPSK (2Mbps)

Channel: 78

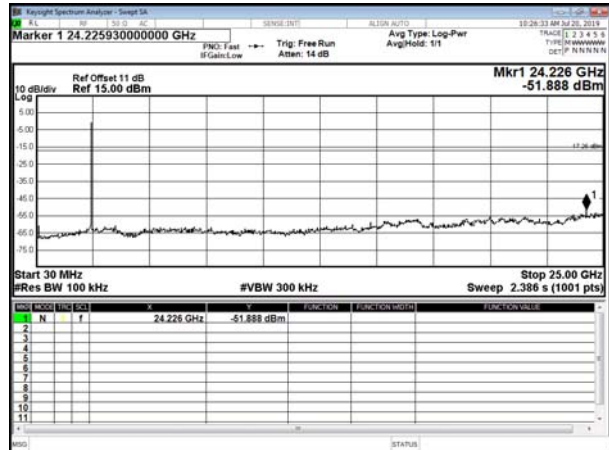
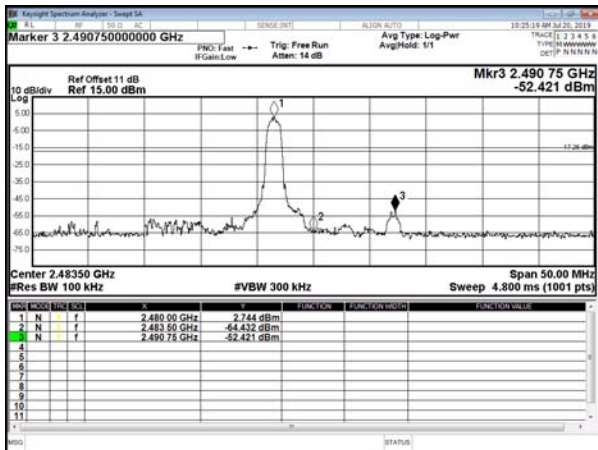



Modulation Standard: 8DPSK (3Mbps)
Channel: 00

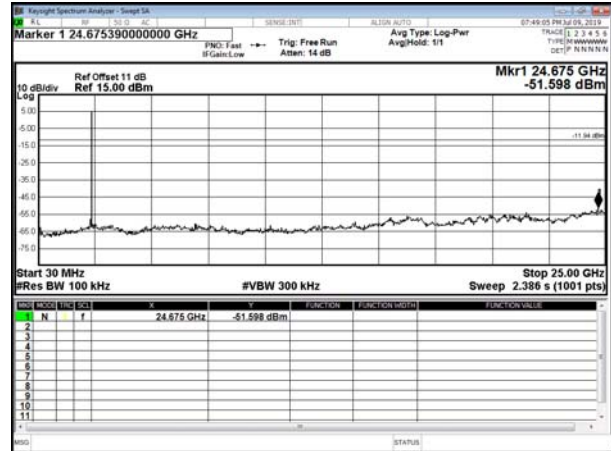
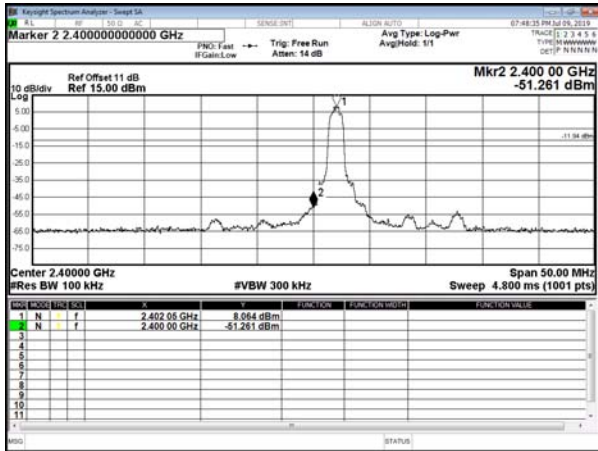

Modulation Standard: 8DPSK (3Mbps)
Channel: 39

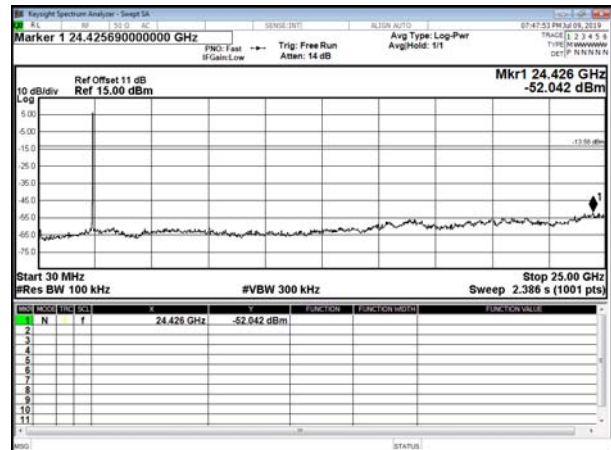
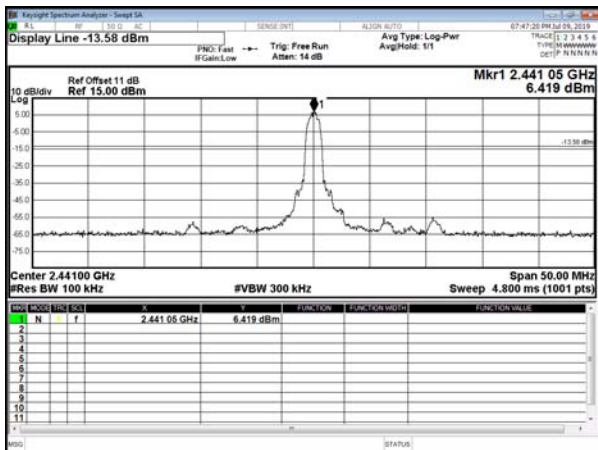

Modulation Standard: 8DPSK (3Mbps)
Channel: 78

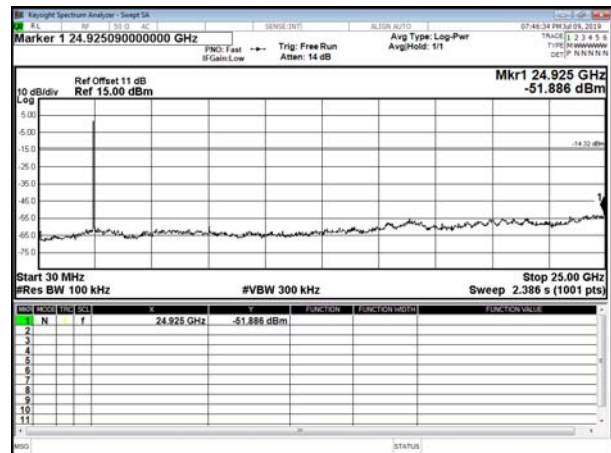
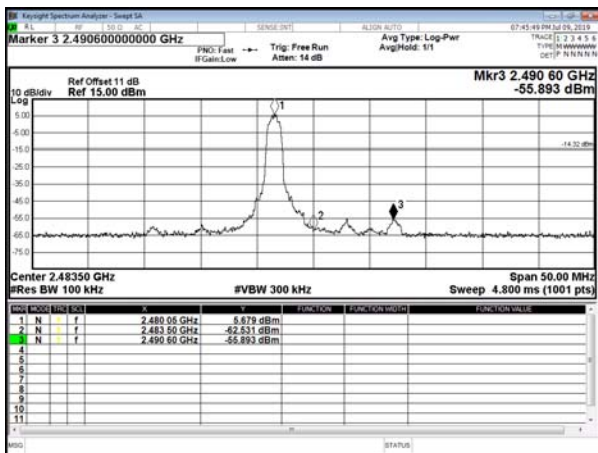



Hopping test

Modulation Standard: GFSK (1Mbps)

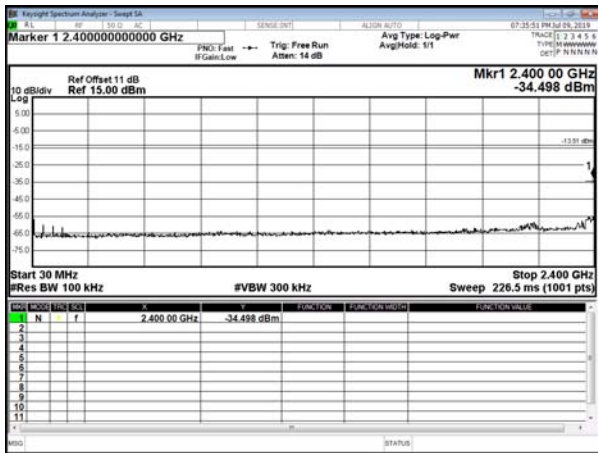

Modulation Standard: GFSK (1Mbps)

Modulation Standard: GFSK (1Mbps)

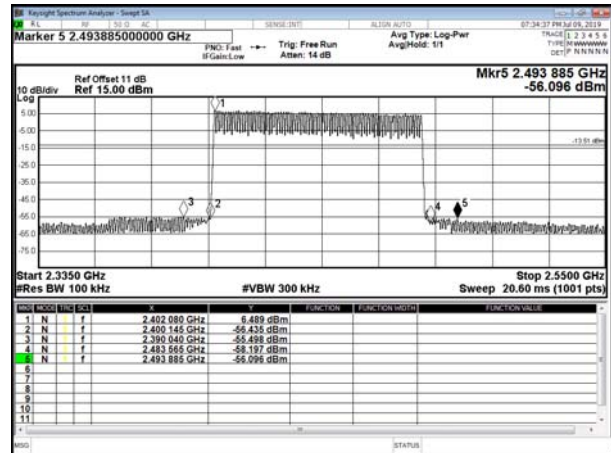

Modulation Standard: $\pi/4$ DQPSK (2Mbps)

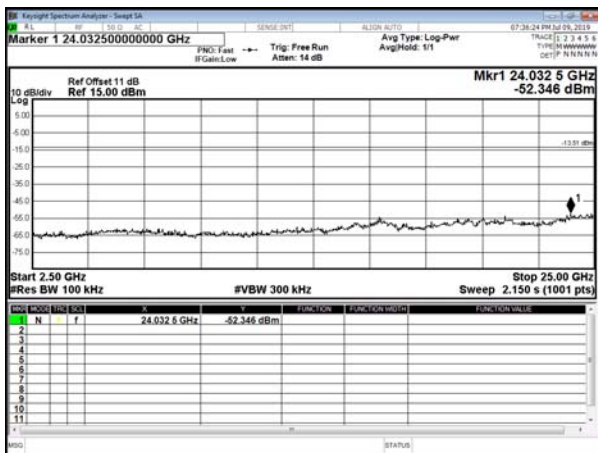

Modulation Standard: $\pi/4$ DQPSK (2Mbps)
Channel: 39

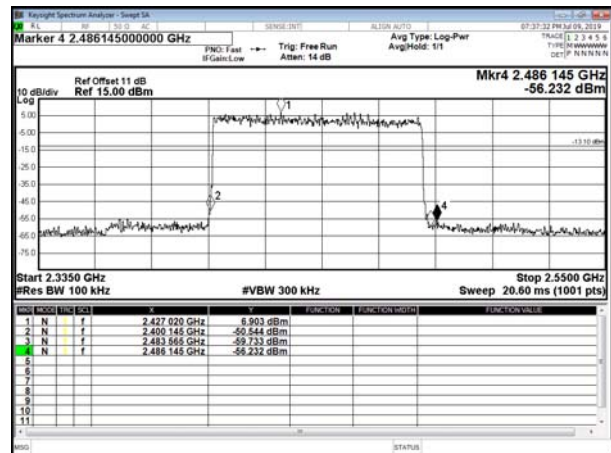

Modulation Standard: $\pi/4$ DQPSK (2Mbps)
Channel: 78

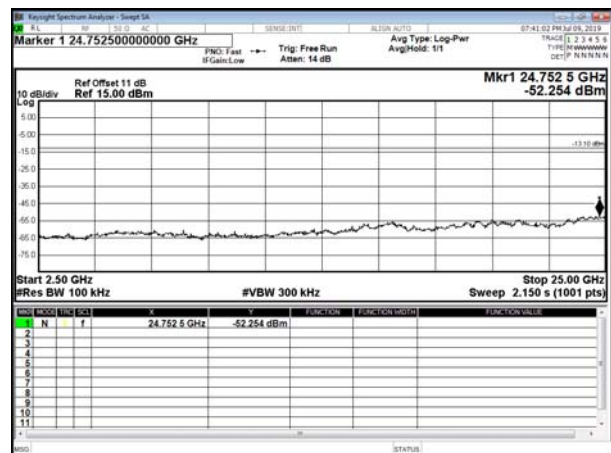
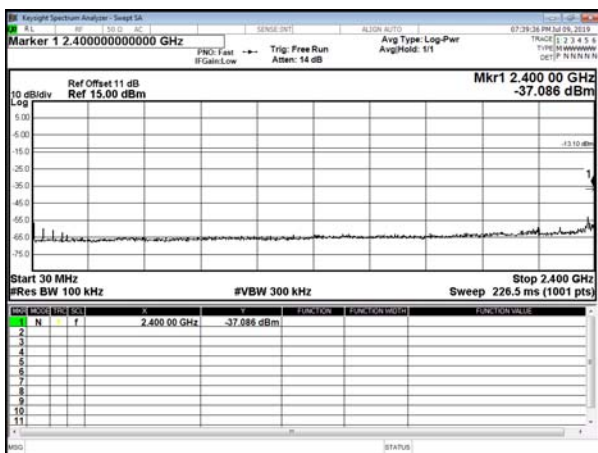



Modulation Standard: 8DPSK (3Mbps)
Channel: 00

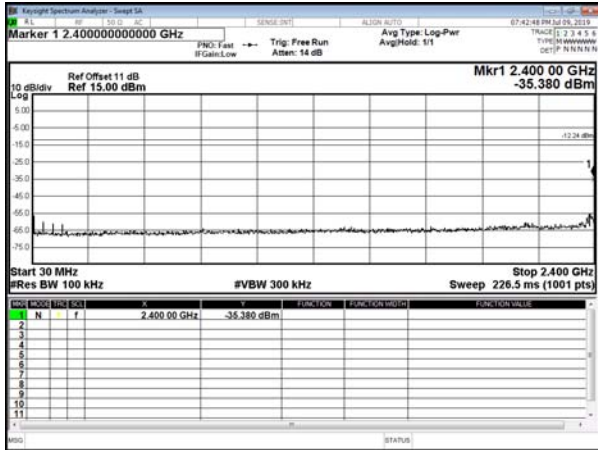

Modulation Standard: 8DPSK (3Mbps)
Channel: 39

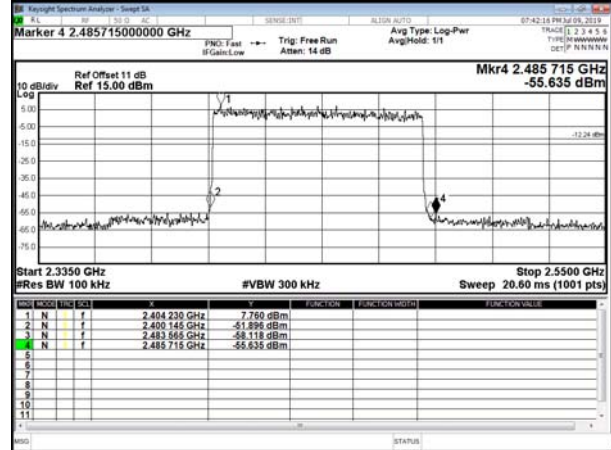

Modulation Standard: 8DPSK (3Mbps)
Channel: 78

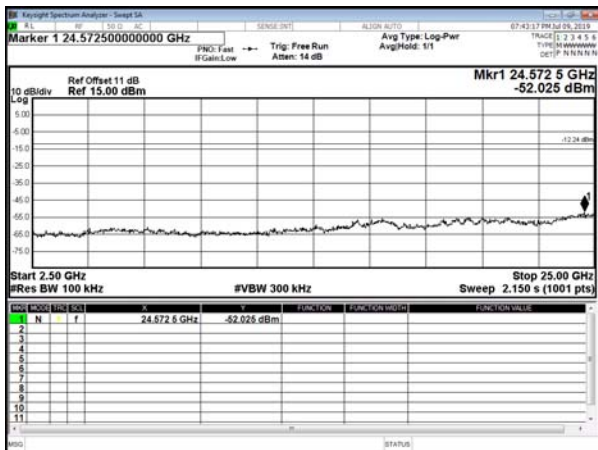



12. Radiated Emission Band Edge Measurement

12.1 Limit

Radiated emissions which fall in the restricted bands, as defined in Section 15.205(a) of FCC part 15, must also comply with the radiated emission limits specified in Section 15.209(a) of FCC part 15.

12.2 Test Procedure

According to ANSI C63.10: 2013.

This test is required for any spurious emission or modulation product that falls in a Restricted Band, as defined in Section 15.205 of FCC part 15. It must be performed with the highest gain of each type of antenna proposed for use with the EUT. Use the following spectrum analyzer settings:

Span = wide enough to fully capture the emission being measured

RBW = 1 MHz for $f \geq 1$ GHz, 100 kHz for $f < 1$ GHz

VBW \geq RBW

Sweep = auto

Detector function = peak

Trace = max hold

Follow the guidelines in ANSI C63.10 with respect to maximizing the emission by rotating the EUT, measuring the emission while the EUT is situated in three orthogonal planes (if appropriate), adjusting the measurement antenna height and polarization, etc. A pre-amp and a high pass filter are required for this test, in order to provide the measuring system with sufficient sensitivity. Allow the trace to stabilize. The peak reading of the emission, after being corrected by the antenna factor, cable loss, pre-amp gain, etc., is the peak field strength, which must comply with the limit specified in Section 15.35(b) of FCC part 15.

Now set the VBW to 10 Hz, while maintaining all of the other instrument settings. This peak level, once corrected, must comply with the limit specified in Section 15.209 of FCC Part 15. If the dwell time per channel of the hopping signal is less than 100 ms, then the reading obtained with the 10 Hz VBW may be further adjusted by a "duty cycle correction factor", derived from $20\log(\text{dwell time}/100 \text{ ms})$, in an effort to demonstrate compliance with the 15.209 limit of FCC part 15.

If the emission on which a radiated measurement must be made is located at the edge of the authorized band of operation, then the alternative "marker-delta" method may be employed.



12.3 Test Setup

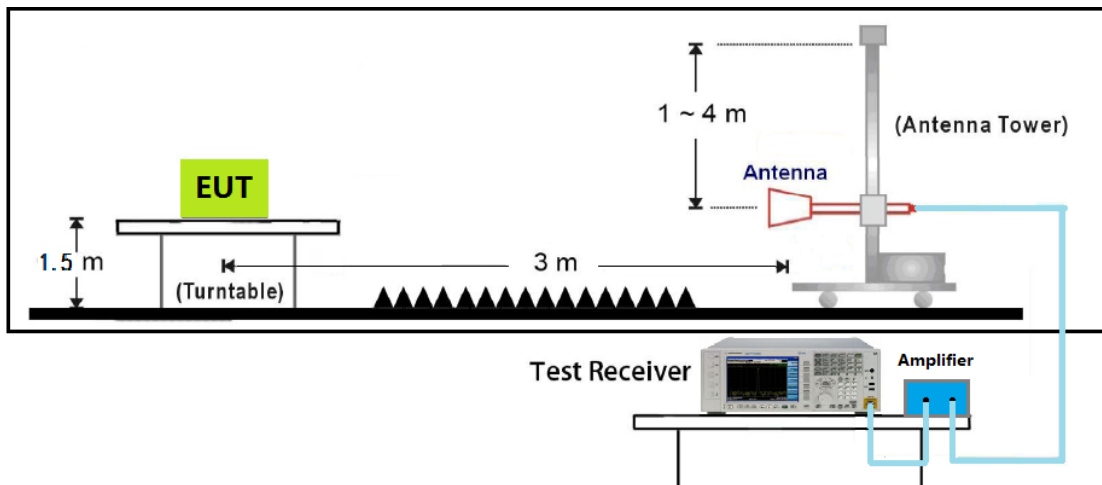



12.4 Test Result

Power	: DC 3.3V	Pol/Phase	: VERTICAL
Test Mode	: GFSK, CH00	Temperature	: 25 °C
Test date	: Jul. 14, 2019	Humidity	: 55 %

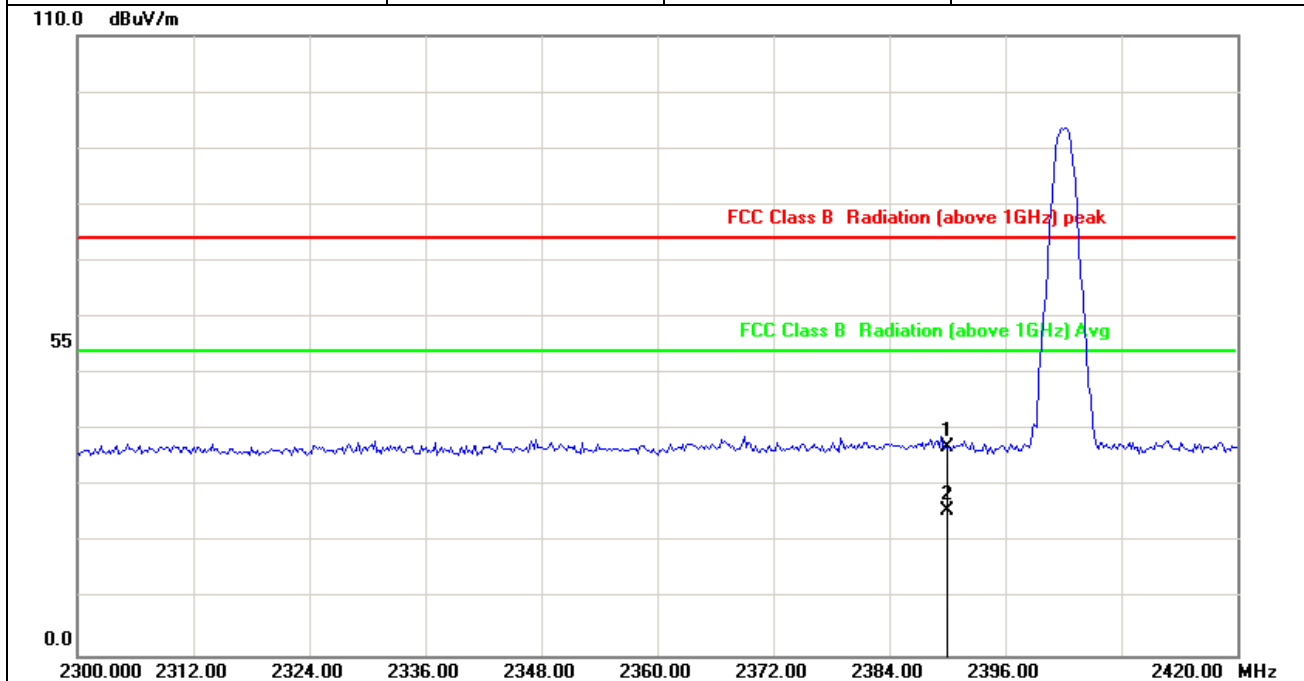

No.	Frequency (MHz)	Factor (dB/m)	Reading (dBuV)	Level (dBuV/m)	Limit (dBuV/m)	Margin (dB)	Detector
1	2390.000	-10.05	47.17	37.12	74.00	-36.88	peak
2	2390.000	-10.05	35.72	25.67	54.00	-28.33	AVG

Note: Level=Reading +Factor.
Margin=Level-Limit.



Power	: DC 3.3V	Pol/Phase	: Horizontal
Test Mode	: GFSK, CH00	Temperature	: 25 °C
Test date	: Jul. 14, 2019	Humidity	: 55 %

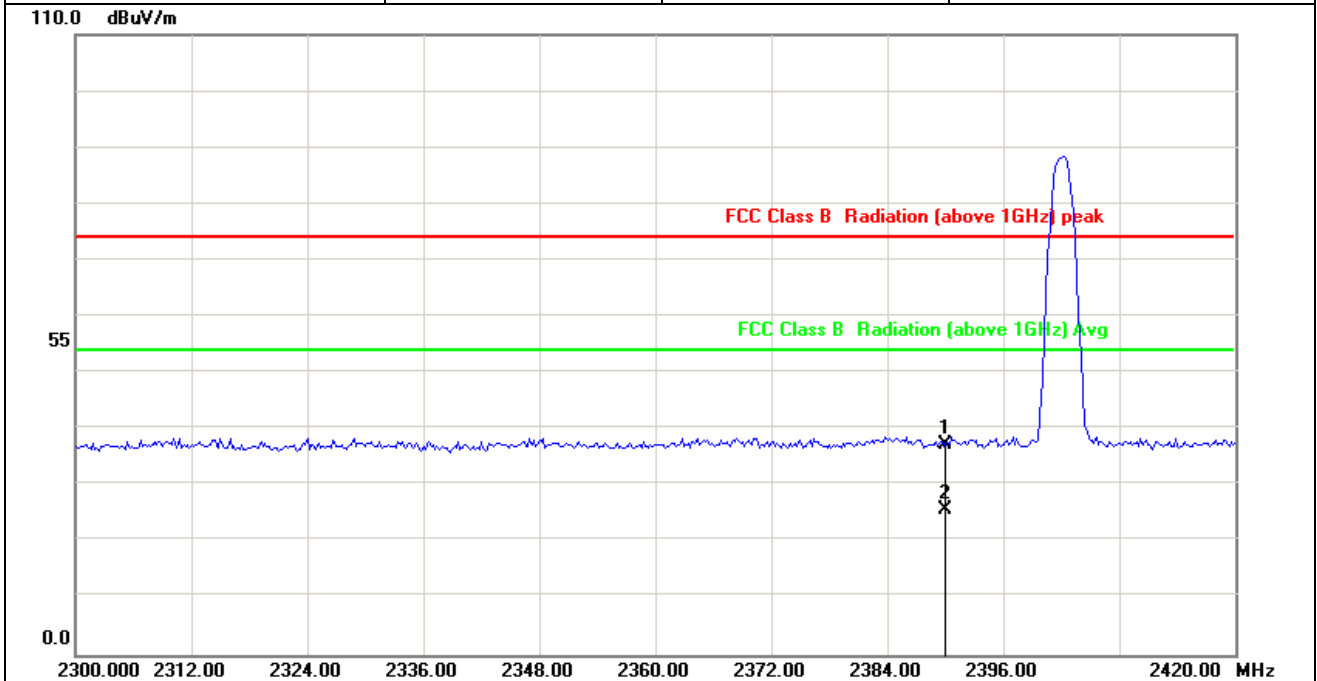

No.	Frequency (MHz)	Factor (dB/m)	Reading (dBuV)	Level (dBuV/m)	Limit (dBuV/m)	Margin (dB)	Detector
1	2390.000	-10.05	47.29	37.24	74.00	-36.76	peak
2	2390.000	-10.05	35.80	25.75	54.00	-28.25	AVG

Note: Level=Reading +Factor.
Margin=Level-Limit.



Power	: DC 3.3V	Pol/Phase	: VERTICAL
Test Mode	: GFSK, CH78	Temperature	: 25 °C
Test date	: Jul. 14, 2019	Humidity	: 55 %

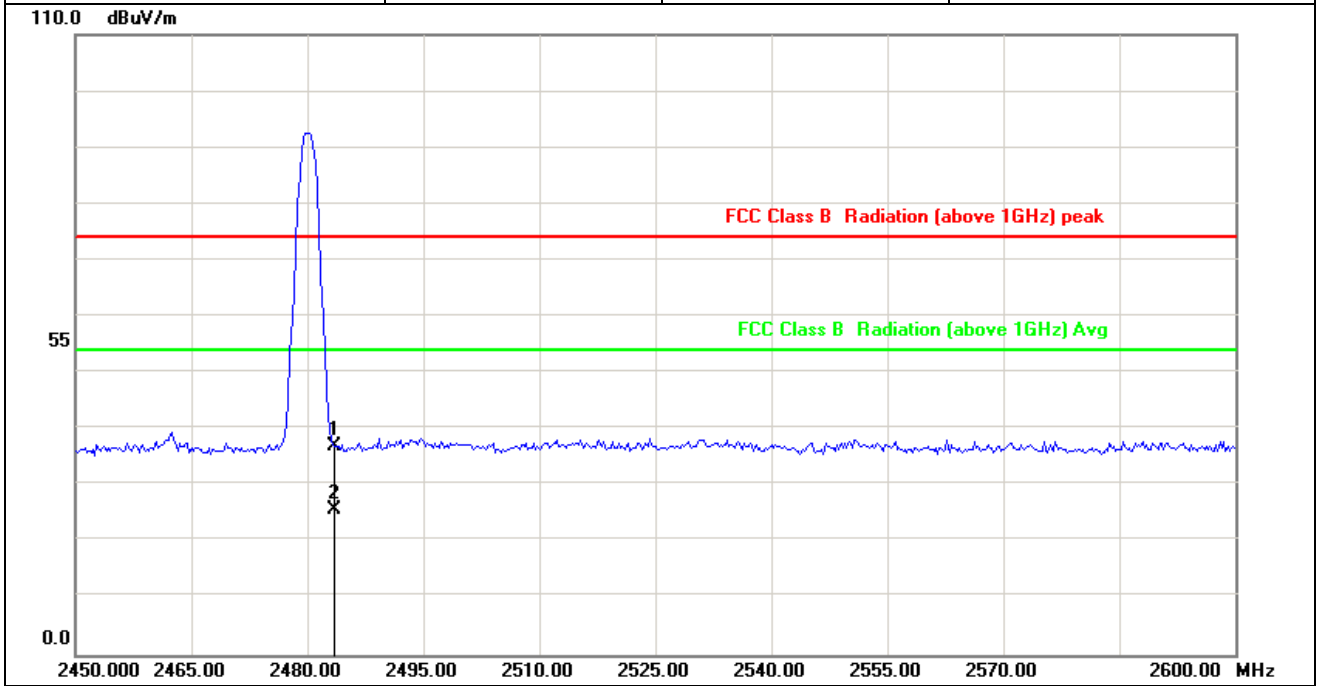

No.	Frequency (MHz)	Factor (dB/m)	Reading (dBuV)	Level (dBuV/m)	Limit (dBuV/m)	Margin (dB)	Detector
1	2483.500	-9.65	46.75	37.10	74.00	-36.90	peak
2	2483.500	-9.65	35.42	25.77	54.00	-28.23	AVG

Note: Level=Reading +Factor.
Margin=Level-Limit.



Power	: DC 3.3V	Pol/Phase	: Horizontal
Test Mode	: GFSK, CH78	Temperature	: 25 °C
Test date	: Jul. 14, 2019	Humidity	: 55 %

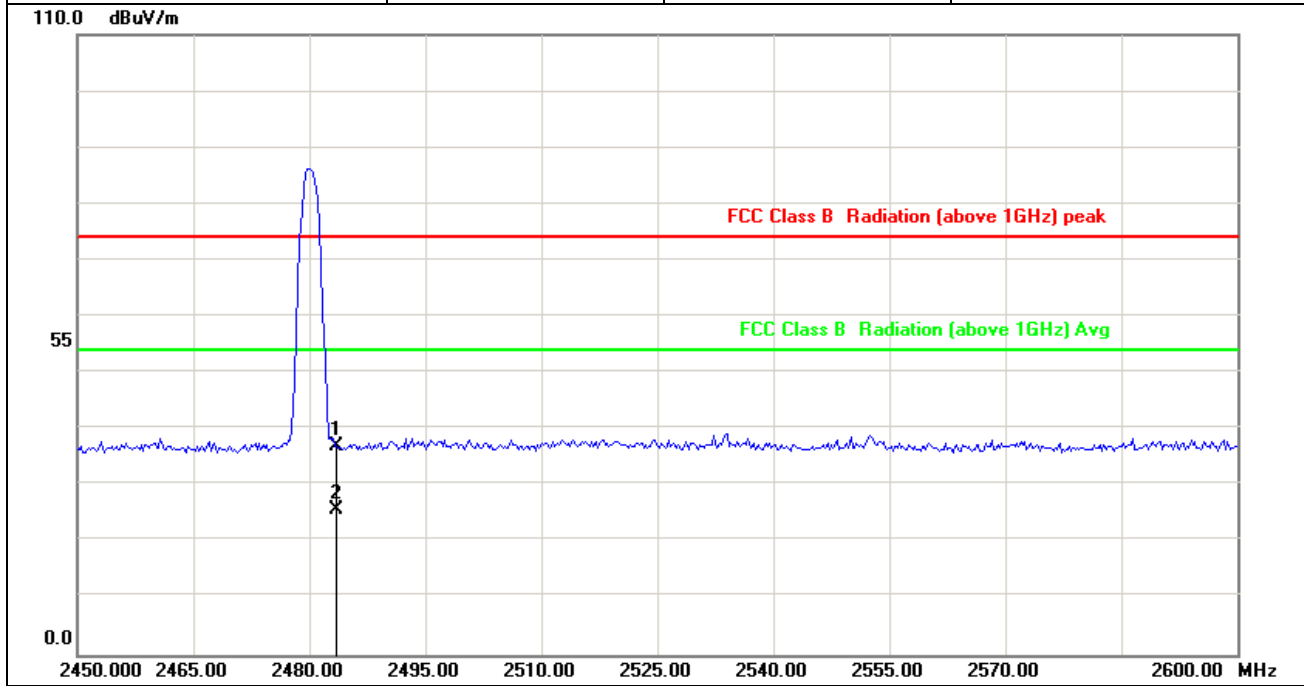

No.	Frequency (MHz)	Factor (dB/m)	Reading (dBuV)	Level (dBuV/m)	Limit (dBuV/m)	Margin (dB)	Detector
1	2483.500	-9.65	46.74	37.09	74.00	-36.91	peak
2	2483.500	-9.65	35.36	25.71	54.00	-28.29	AVG

Note: Level=Reading +Factor.
Margin=Level-Limit.



Power	: DC 3.3V	Pol/Phase	: VERTICAL
Test Mode	: $\pi/4$ DQPSK, CH00	Temperature	: 25 °C
Test date	: Jul. 14, 2019	Humidity	: 55 %

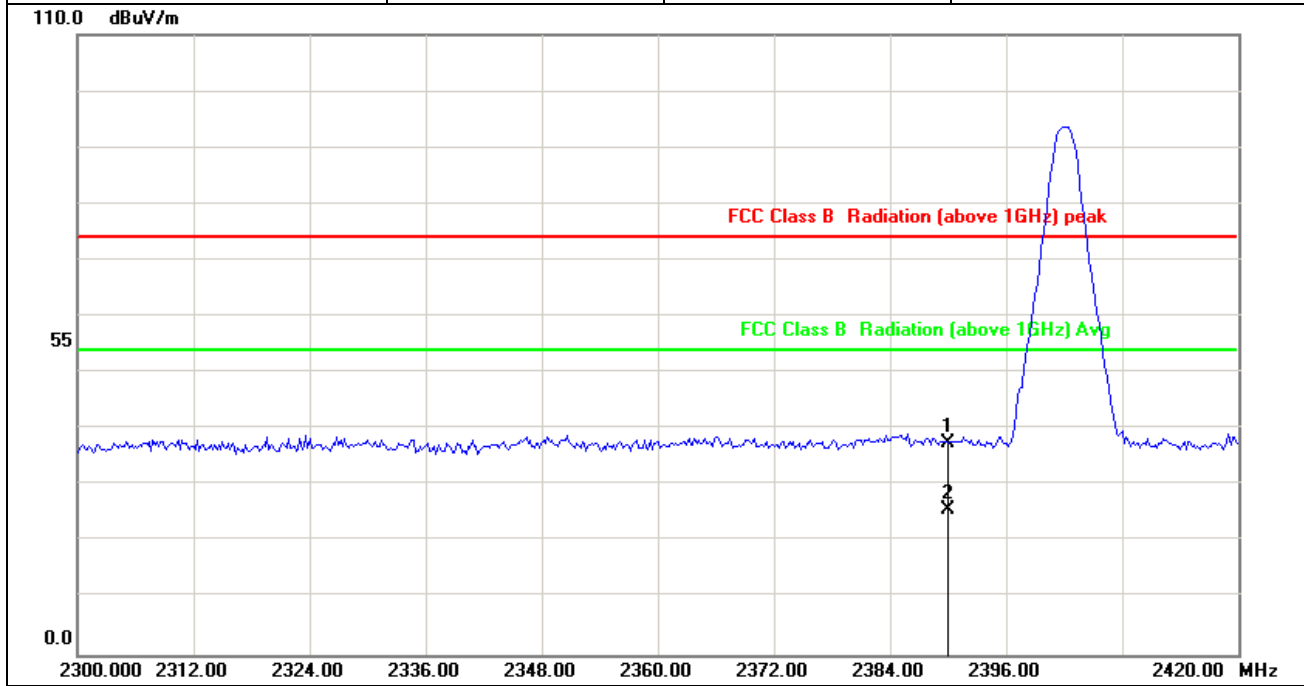

No.	Frequency (MHz)	Factor (dB/m)	Reading (dBuV)	Level (dBuV/m)	Limit (dBuV/m)	Margin (dB)	Detector
1	2390.000	-10.05	47.65	37.60	74.00	-36.40	peak
2	2390.000	-10.05	35.68	25.63	54.00	-28.37	AVG

Note: Level=Reading +Factor.
Margin=Level-Limit.



Power	: DC 3.3V	Pol/Phase	: Horizontal
Test Mode	: $\pi/4$ DQPSK, CH00	Temperature	: 25 °C
Test date	: Jul. 14, 2019	Humidity	: 55 %

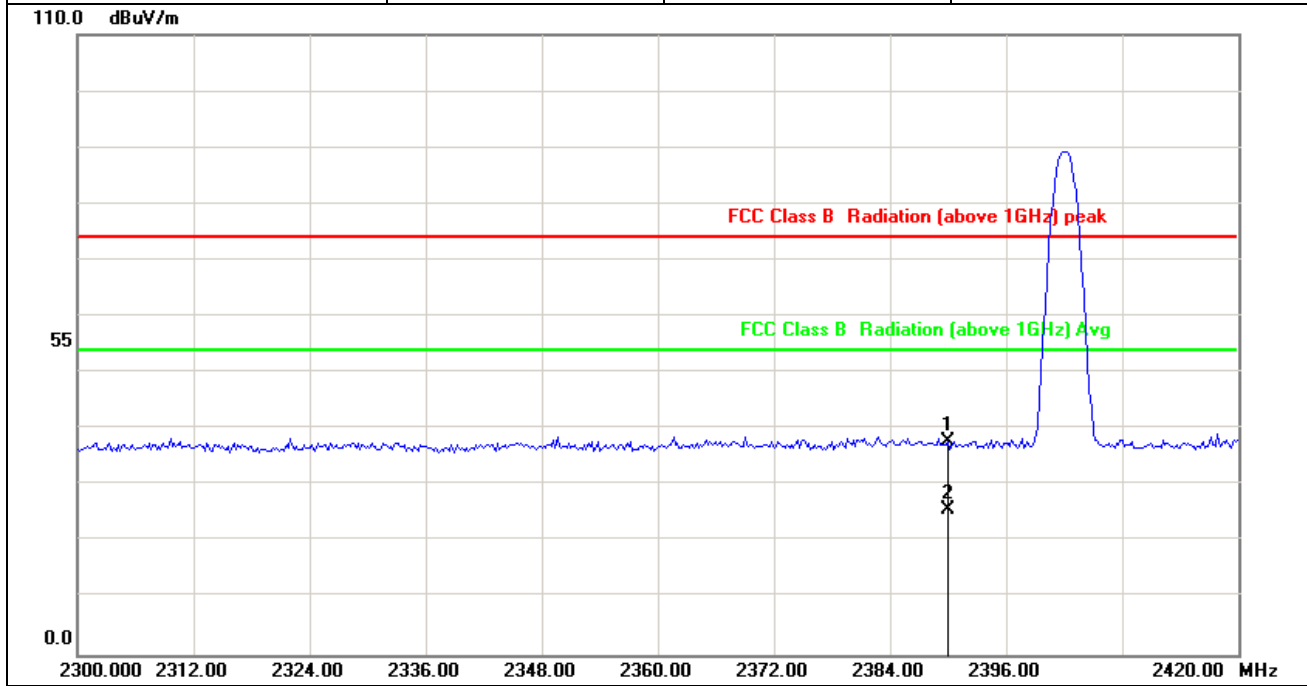

No.	Frequency (MHz)	Factor (dB/m)	Reading (dBuV)	Level (dBuV/m)	Limit (dBuV/m)	Margin (dB)	Detector
1	2390.000	-10.05	47.99	37.94	74.00	-36.06	peak
2	2390.000	-10.05	35.74	25.69	54.00	-28.31	AVG

Note: Level=Reading +Factor.
Margin=Level-Limit.



Power	: DC 3.3V	Pol/Phase	: VERTICAL
Test Mode	: $\pi/4$ DQPSK, CH78	Temperature	: 25 °C
Test date	: Jul. 14, 2019	Humidity	: 55 %

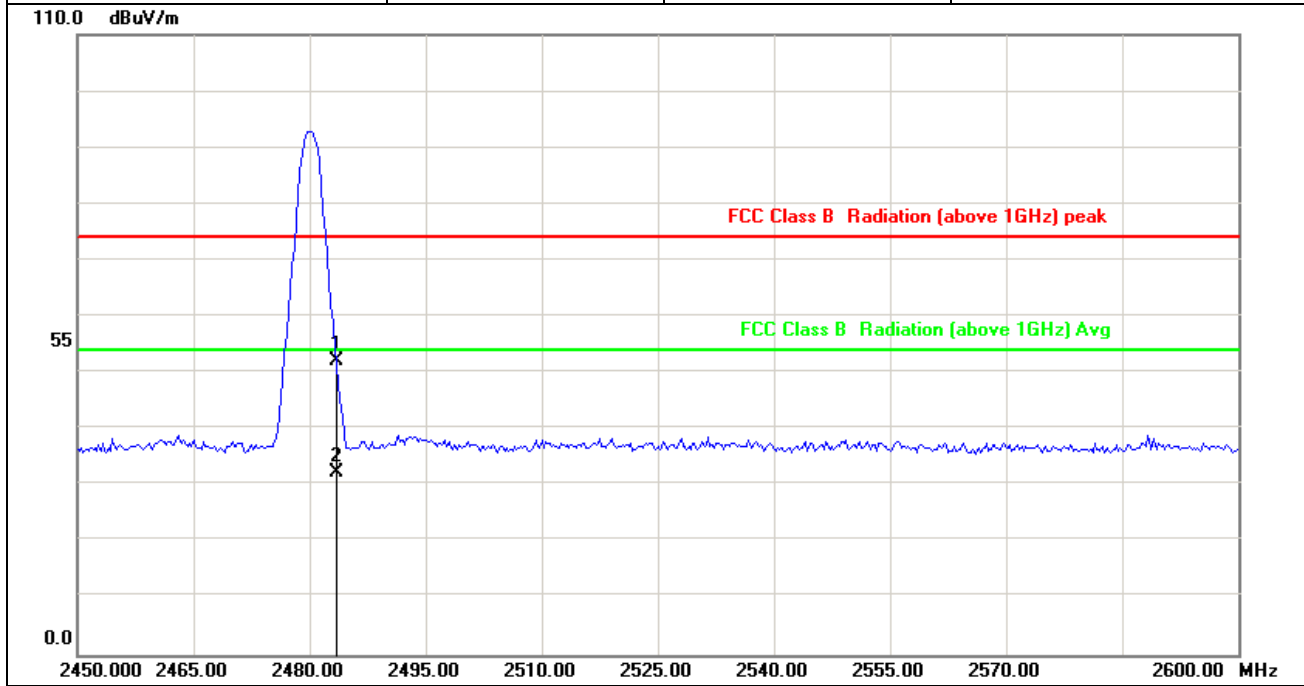

No.	Frequency (MHz)	Factor (dB/m)	Reading (dBuV)	Level (dBuV/m)	Limit (dBuV/m)	Margin (dB)	Detector
1	2483.500	-9.65	61.83	52.18	74.00	-21.82	peak
2	2483.500	-9.65	41.96	32.31	54.00	-21.69	AVG

Note: Level=Reading +Factor.
Margin=Level-Limit.



Power	: DC 3.3V	Pol/Phase	: Horizontal
Test Mode	: $\pi/4$ DQPSK, CH78	Temperature	: 25 °C
Test date	: Jul. 14, 2019	Humidity	: 55 %

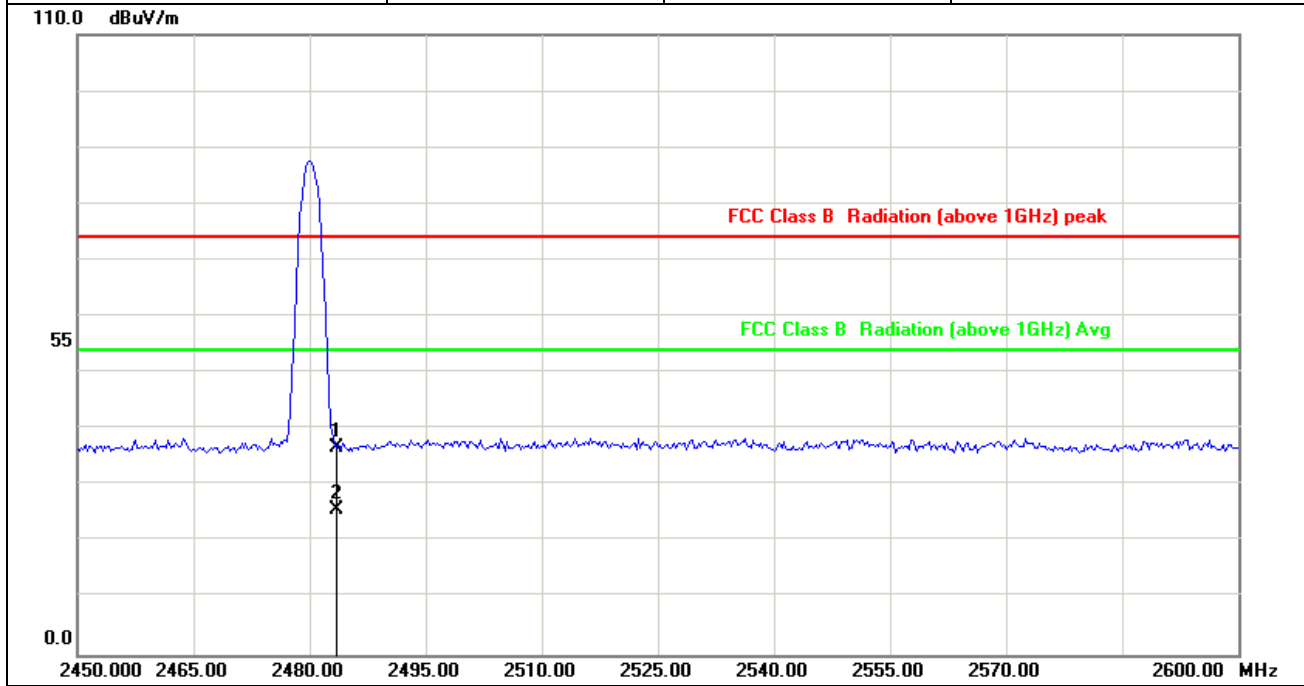

No.	Frequency (MHz)	Factor (dB/m)	Reading (dBuV)	Level (dBuV/m)	Limit (dBuV/m)	Margin (dB)	Detector
1	2483.500	-9.65	46.39	36.74	74.00	-37.26	peak
2	2483.500	-9.65	35.46	25.81	54.00	-28.19	AVG

Note: Level=Reading +Factor.
Margin=Level-Limit.



Power	: DC 3.3V	Pol/Phase	: VERTICAL
Test Mode	: 8DPSK, CH00	Temperature	: 25 °C
Test date	: Jul. 14, 2019	Humidity	: 55 %

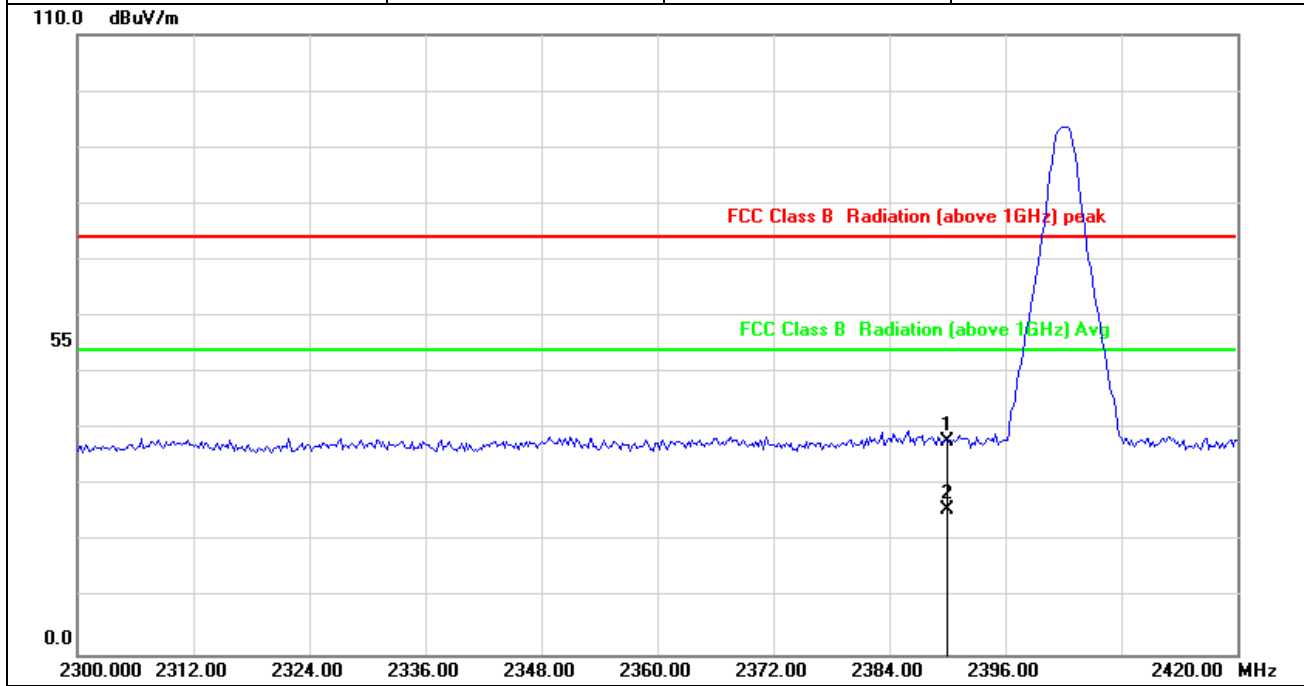

No.	Frequency (MHz)	Factor (dB/m)	Reading (dBuV)	Level (dBuV/m)	Limit (dBuV/m)	Margin (dB)	Detector
1	2390.000	-10.05	47.75	37.70	74.00	-36.30	peak
2	2390.000	-10.05	35.87	25.82	54.00	-28.18	AVG

Note: Level=Reading +Factor.
Margin=Level-Limit.



Power	: DC 3.3V	Pol/Phase	: Horizontal
Test Mode	: 8DPSK, CH00	Temperature	: 25 °C
Test date	: Jul. 14, 2019	Humidity	: 55 %

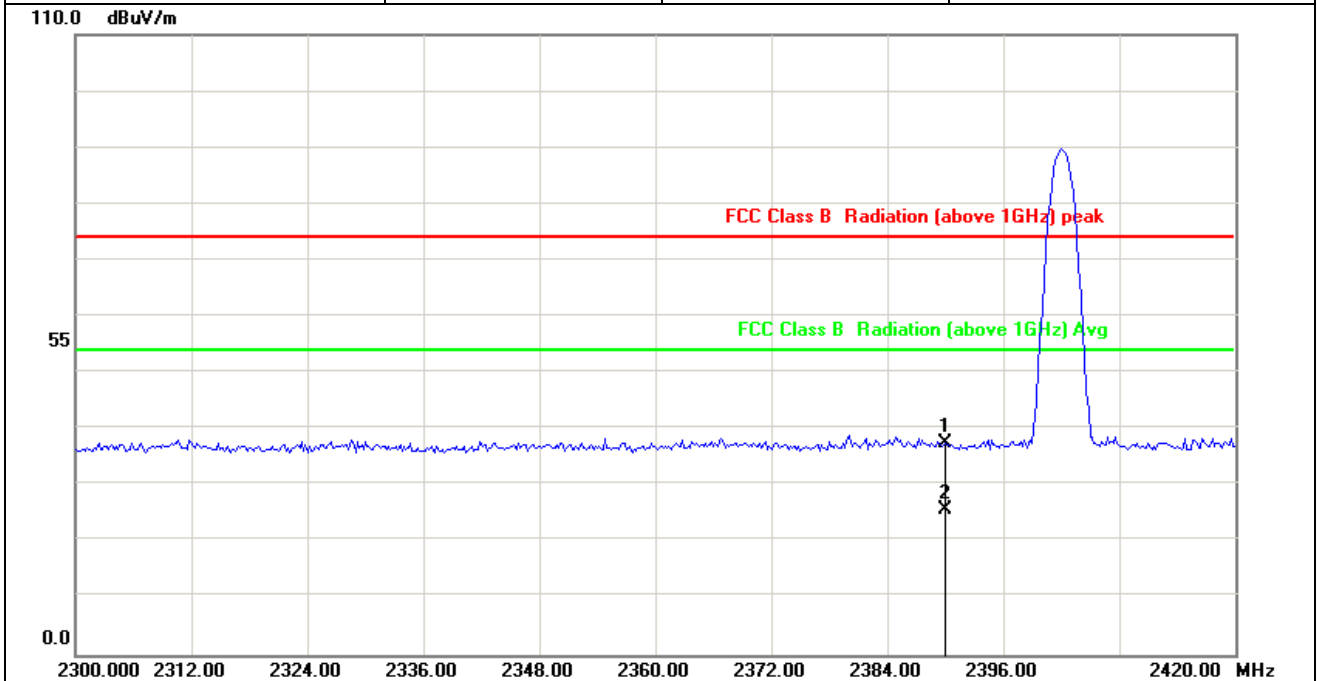

No.	Frequency (MHz)	Factor (dB/m)	Reading (dBuV)	Level (dBuV/m)	Limit (dBuV/m)	Margin (dB)	Detector
1	2390.000	-10.05	47.70	37.65	74.00	-36.35	peak
2	2390.000	-10.05	35.84	25.79	54.00	-28.21	AVG

Note: Level=Reading +Factor.
Margin=Level-Limit.



Power	: DC 3.3V	Pol/Phase	: VERTICAL
Test Mode	: 8DPSK, CH78	Temperature	: 25 °C
Test date	: Jul. 14, 2019	Humidity	: 55 %

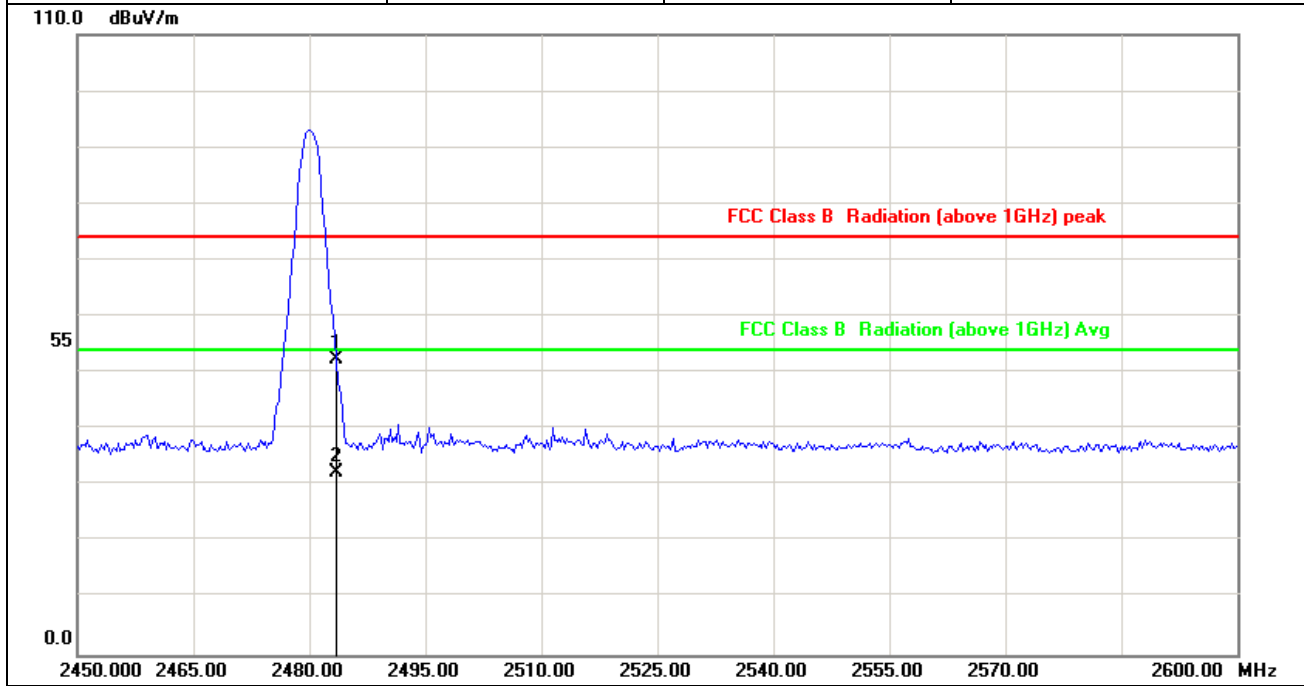

No.	Frequency (MHz)	Factor (dB/m)	Reading (dBuV)	Level (dBuV/m)	Limit (dBuV/m)	Margin (dB)	Detector
1	2483.500	-9.65	62.05	52.40	74.00	-21.60	peak
2	2483.500	-9.65	42.07	32.42	54.00	-21.58	AVG

Note: Level=Reading +Factor.
Margin=Level-Limit.



Power	: DC 3.3V	Pol/Phase	: Horizontal
Test Mode	: 8DPSK, CH78	Temperature	: 25 °C
Test date	: Jul. 14, 2019	Humidity	: 55 %

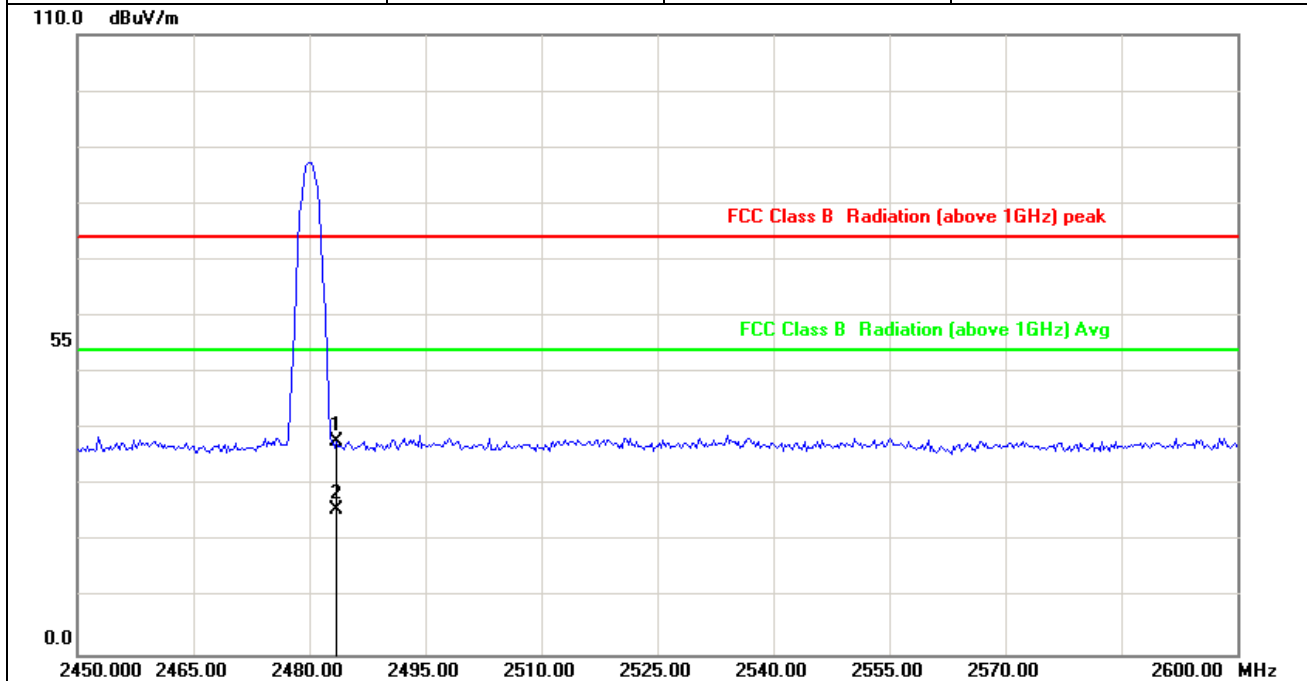

No.	Frequency (MHz)	Factor (dB/m)	Reading (dBuV)	Level (dBuV/m)	Limit (dBuV/m)	Margin (dB)	Detector
1	2483.500	-9.65	47.38	37.73	74.00	-36.27	peak
2	2483.500	-9.65	35.44	25.79	54.00	-28.21	AVG

Note: Level=Reading +Factor.
Margin=Level-Limit.

_____ The End _____