



FCC AND ISED CERTIFICATION TEST REPORT

Applicant:	Guangzhou Shirui Electronics Co.,Ltd
Address:	192 Kezhu Road, Sciencetech Park, Guangzhou Economic & Technology Development District, Guangzhou, China
Manufacturer:	Guangzhou Shirui Electronics Co.,Ltd
Address:	192 Kezhu Road, Sciencetech Park, Guangzhou Economic & Technology Development District, Guangzhou, China
Product Description:	Interactive Intelligent Panel
Brand Name:	NA
Tested Model:	CH65GC, CH75GC
FCC ID:	2AFG6-CHXXGC
IC:	22166-CHXXGC
Report No.:	JCF240923023-008
Received Date:	Sep. 18, 2024
Tested Date:	Sep. 18, 2024 - Oct. 25, 2024
Issued Date:	Oct. 25, 2024
Test Standards:	FCC Rules and Regulations Part 15 Subpart C, RSS-247 Issue 3 August 2023
Test Procedure:	ANSI C63.10:2013, RSS-Gen Issue 5 A2, Feb. 2021
Test Result:	Pass
Prepared By:	
<i>Kennys Zhang</i>	
<u>Kennys Zhang/Engineer</u>	Date: Oct. 25, 2024
Reviewed By:	
<i>Roger Li</i>	
<u>Roger Li/Engineer</u>	Date: Oct. 25, 2024
Approved By:	
<i>Talent Zhang</i>	
<u>Talent Zhang/Engineer</u>	Date: Oct. 25, 2024

Note: The test results in this report apply exclusively to the tested model / sample. Without written approval of Guangzhou Jingce Testing Technology Co., Ltd. the test report shall not be reproduced except in full.

Report Revise Record

Report Version	Revise Time	Issued Date	Valid Version	Notes
V1.0	/	Oct. 25, 2024	Original Report	/

TABLE OF CONTENTS

1. Test Report Declare	5
2. Summary of Test Results	6
3. Test Laboratory	6
4. Equipment Under Test	7
4.1. Description of EUT	7
4.2. Channel List	7
4.3. Test Channel Configuration	7
4.4. Test environment conditions	8
4.5. The Worse Case Power Setting Parameter	8
4.6. Description of Available Antennas	8
5. Description of Test Setup	8
5.1. Accessory	8
5.2. Support Equipment	8
5.3. Test Setup	8
5.4. Setup Diagram for Tests	8
6. Measurement Uncertainty	9
7. Measuring Instrument and Software Used	9
8. On Time and Duty Cycle	11
8.1. Block diagram of test setup	11
8.2. Limits	11
8.3. Procedure	11
8.4. Results	11
8.5. Original test data	11
9. 6 dB DTS Bandwidth and 99 % Bandwidth	14
9.1. Block diagram of test setup	14
9.2. Limits	14
9.3. Test Procedure	14
9.4. Results	14
9.5. Original test data	15
10. Peak Conducted Output Power	19
10.1. Block diagram of test setup	19
10.2. Limits	19
10.3. Test Procedure	19
10.4. Results	19
10.5. Original test data	20
11. Power Spectral Density	22
11.1. Block diagram of test setup	22
11.2. Limits	22
11.3. Test Procedure	22
11.4. Results	22
11.5. Original test data	22
12. Conducted Bandedge and Spurious Emissions	25
12.1. Block diagram of test setup	25
12.2. Limits	25
12.3. Test Procedure	25
12.4. Results	25
12.5. Original test data	26
13. Radiated Emission	34
13.1. Block diagram of test setup	34
13.2. Limit	35
13.3. Test Procedure	36
13.4. Results	38

- 13.5. Original test data 38
- 14. AC Power Line Conducted Emissions 39**
 - 14.1. Block diagram of test setup 39
 - 14.2. Limits 39
 - 14.3. Test procedure 39
 - 14.4. Test result 40
 - 14.5. Original test data 40
- 15. Antenna Requirements 41**
 - 15.1. Limits 41
 - 15.2. Result 41
- APPENDIX A – Radiated Emission Below 1GHz Test Data 42**
- APPENDIX B – Radiated Emission Above 1GHz Test Data 46**
- APPENDIX C – AC Power Line Conducted Emission Test Data 74**

1. Test Report Declare

Applicant:	Guangzhou Shirui Electronics Co.,Ltd
Address:	192 Kezhu Road, Scientech Park, Guangzhou Economic & Technology Development District, Guangzhou, China
Manufacturer:	Guangzhou Shirui Electronics Co.,Ltd
Address:	192 Kezhu Road, Scientech Park, Guangzhou Economic & Technology Development District, Guangzhou, China
Product Name:	Interactive Intelligent Panel
Brand Name:	NA
Model Name:	CH65GC, CH75GC
Difference Description:	Compare with CH65GC, CH75GC only the appearance, size ,LCD panel ,T-CON board and power main board are different, others completely the same.

We Declare:

The equipment described above is tested by Guangzhou Jingce Testing Technology Co., Ltd. and in the configuration tested the equipment complied with the standards specified above. The test results are contained in this test report and Guangzhou Jingce Testing Technology Co., Ltd. is assumed of full responsibility for the accuracy and completeness of these tests except as provided information by clients.

2. Summary of Test Results

Summary of Test Results			
Clause	Test Items	FCC/ISED Rules	Test Results
1	6 dB Bandwidth and 99 % Occupied Bandwidth	FCC Part 15.247 (a) (2) RSS-247 Clause 5.2 (a) ISED RSS-Gen Clause 6.7	Pass
2	Peak Conducted Output Power	FCC Part 15.247 (b) (3) RSS-247 Clause 5.4 (d)	Pass
3	Power Spectral Density	FCC Part 15.247 (e) RSS-247 Clause 5.2 (b)	Pass
4	Conducted Bandedge and Spurious Emission	FCC Part 15.247 (d) RSS-247 Clause 5.5	Pass
5	Radiated Bandedge and Spurious Emission	FCC Part 15.247 (d) FCC Part 15.209 FCC Part 15.205 RSS-247 Clause 5.5 RSS-GEN Clause 8.9	Pass
6	Conducted Emission Test For AC Power Port	FCC Part 15.207 RSS-GEN Clause 8.8	Pass
7	Antenna Requirement	FCC Part 15.203 RSS-GEN Clause 6.8	Pass

Note: All models' RF hardware and software, including modules, crystal oscillator, antenna, function exactly the same. According to the pretest results, the differences between the models only affect the results of the Radiated Emission (30MHz-40GHz) and Power Line Conducted Emissions. Therefore, in addition to the two test projects, the test results of two models (CH65GC, CH75GC) were recorded, and the test results of the remaining projects were only recorded for the worst model, CH65GC.

3. Test Laboratory

Guangzhou Jingce Testing Technology Co., Ltd.

Add.: No.10, Hefeng No.1 street, Huangpu District, Guangzhou, Guangdong, People's Republic of China

Association for Laboratory Accreditation(A2LA). Certificate Number: 6594.03

FCC Designation Number: CN1381. Test Firm Registration Number: 486550

IC Test Firm Registration Number: 31808

Conformity Assessment Body identifier: CN0173

4. Equipment Under Test

4.1. Description of EUT

EUT Name:	Interactive Intelligent Panel
Model Number:	CH65GC, CH75GC
EUT Function Description:	Please refer to user manual of this device
Power Supply:	100-240V~ 50/60Hz 3.5A
Hardware Version:	N/A
Software Version:	N/A
Radio Specification:	Bluetooth V5.4
Operation Frequency:	2402 MHz - 2480 MHz
Modulation:	GFSK
Data Rate:	1Mbps, 2Mbps,
Antenna Type:	SMA Antenna, MAX. Gain: 4.06 dBi

Note 1: EUT is the ab. of equipment under test.

Note 2: The antenna gain is declared by the customer and the laboratory is not responsible for the accuracy of the antenna gain.

4.2. Channel List

Channel	Frequency (MHz)	Channel	Frequency (MHz)	Channel	Frequency (MHz)	Channel	Frequency (MHz)
0	2402	11	2424	22	2446	33	2468
1	2404	12	2426	23	2448	34	2470
2	2406	13	2428	24	2450	35	2472
3	2408	14	2430	25	2452	36	2474
4	2410	15	2432	26	2454	37	2476
5	2412	16	2434	27	2456	38	2478
6	2414	17	2436	28	2458	39	2480
7	2416	18	2438	29	2460	/	/
8	2418	19	2440	30	2462	/	/
9	2420	20	2442	31	2464	/	/
10	2422	21	2444	32	2468	/	/

4.3. Test Channel Configuration

Tested mode, channel, information		
Mode	Channel	Frequency (MHz)
GFSK	LCH:CH0	2402
	MCH:CH19	2440
	HCH:CH39	2480

4.4. Test environment conditions

During the measurement the environmental conditions were within the listed ranges:

Temperature range:	21-25 °C
Humidity range:	40-75%
Pressure range:	86-106 kPa

4.5. The Worse Case Power Setting Parameter

The Worse Case Power Setting Parameter under 2400 ~ 2483.5MHz Band				
Test Software		MobaXterm		
Modulation Type	Transmit Antenna Number	Test Software Setting Value		
		CH 00	CH 39	CH 78
GFSK 1M	1	Default	Default	Default
GFSK 2M	1	Default	Default	Default

4.6. Description of Available Antennas

Test Mode	Transmit and Receive Mode	Description
GFSK	<input checked="" type="checkbox"/> 1TX, 1RX	Antenna 1 can be used as transmitting/receiving antenna.

5. Description of Test Setup

5.1. Accessory

Description of Accessories	Manufacturer	Model Number	Description	Remark
N/A	N/A	N/A	N/A	N/A

5.2. Support Equipment

Equipment	Brand Name	Model Name	P/N
PC	Lenovo	T480	/

5.3. Test Setup

The EUT can work in Fixed Frequency mode.

5.4. Setup Diagram for Tests



6. Measurement Uncertainty

Where relevant, the following measurement uncertainty levels have been estimated for tests performed on the apparatus:

Test Item	Uncertainty
AC Power Conduction emission	1.37 dB
All Radiated emissions	5.4dB
Conducted emissions	3.09 dB
Occupied Channel Bandwidth	1.1%
Conducted Output power	0.82dB
Power Spectral Density	0.82dB

Note: This uncertainty represents an expanded uncertainty expressed at approximately the 95 % confidence level using a coverage factor of $k = 2$.

7. Measuring Instrument and Software Used

TS Test System						
Used	Equipment	Manufacturer	Model No.	Serial No.	Last Cal.	Due. Date
<input checked="" type="checkbox"/>	Spectrum Analyzer	Keysight	N9030B	MY56320512	Aug. 22, 2024	Aug. 21, 2025
<input checked="" type="checkbox"/>	Vector Signal Generator	Keysight	N5182B	MY57300334	Aug. 22, 2024	Aug. 21, 2025
<input checked="" type="checkbox"/>	Signal Generator	Keysight	N5171B	MY57280639	Aug. 22, 2024	Aug. 21, 2025
<input checked="" type="checkbox"/>	DC POWER	Keysight	E342A	MY59020356	Aug. 29, 2024	Aug. 28, 2025
<input checked="" type="checkbox"/>	Incubator thermometer	GWS	EL-02JA	21107288	Aug. 15, 2024	Aug. 14, 2025
<input checked="" type="checkbox"/>	Control unit(Power sensor)	Tonscend	JS0806-2	/	Aug. 23, 2024	Aug. 22, 2025
<input checked="" type="checkbox"/>	Spectrum Analyzer	Keysight	N9020B	MY60112206	Sep. 11, 2024	Sep. 10, 2025
<input checked="" type="checkbox"/>	Control unit(Power sensor)	Tonscend	JS0806-2	21H8060465	Aug. 22, 2024	Aug. 21, 2025
<input checked="" type="checkbox"/>	Spectrum Analyzer	Keysight	N9020B	MY60112811	Aug. 23, 2024	Aug. 22, 2025
<input checked="" type="checkbox"/>	Signal Generator	Keysight	N5173B	MY62220145	Aug. 23, 2024	Aug. 22, 2025
<input checked="" type="checkbox"/>	Vector Signal Generator	Keysight	N5182B	MY61252859	Aug. 22, 2024	Aug. 21, 2025
<input checked="" type="checkbox"/>	DC POWER	Keysight	E3642A	MY40005294	Aug. 30, 2024	Aug. 29, 2025
<input checked="" type="checkbox"/>	Control unit(Power sensor)	Tonscend	JS0806-2	24F80620865	Aug. 23, 2024	Aug. 22, 2025
Software						
Used	Description	Manufacturer	Name		Version	
<input checked="" type="checkbox"/>	Test software	Tonscend	JS1120-3		V3.3.10	
RSE Test System						
Used	Equipment	Manufacturer	Model No.	Serial No.	Last Cal.	Due. Date
<input checked="" type="checkbox"/>	EMI Receiver	R&S	ESR26	101424	Sep. 14, 2024	Sep. 13, 2025
<input checked="" type="checkbox"/>	Hybrid Antenna	Schwarzbeck	VULB9163	01416	May. 22, 2024	May. 21, 2025

<input checked="" type="checkbox"/>	Horn Antenna 1	Schwarzbeck	BBHA 9120 D	02910	Sep. 11, 2024	Sep. 10, 2025
<input checked="" type="checkbox"/>	Horn Antenna 2	ETS	BBHA 9170	1090	Sep. 11, 2024	Sep. 10, 2025
<input checked="" type="checkbox"/>	loop-antenna	Schwarzbeck	FMZB 1513-60	00030	Jan. 14, 2024	Jan. 13, 2025
<input checked="" type="checkbox"/>	Test path	/	Path2: WIFI-2.4G 1-3GHz	/	Aug. 23, 2024	Aug. 22, 2025
<input checked="" type="checkbox"/>	Test path	/	Path7: ALL PASS 1-18GHz	/	Aug. 23, 2024	Aug. 22, 2025
<input checked="" type="checkbox"/>	Test path	/	Path9: 3GHz High PASS 3-18GHz	/	Aug. 23, 2024	Aug. 22, 2025
<input checked="" type="checkbox"/>	Test path	/	Path16: 30MHz-1GHz ALL PASS NO AMP	/	Aug. 23, 2024	Aug. 22, 2025
<input checked="" type="checkbox"/>	Signal Pre-Amplifier	ETS	3116C-PA	00217677	Sep. 06, 2024	Sep. 05, 2025
<input checked="" type="checkbox"/>	3m Fully-anechoic Chamber	YIHENG	9m*6m*6m	001	Sep. 05, 2023	Sep. 04, 2026
Software						
Used	Description	Manufacturer	Name		Version	
<input checked="" type="checkbox"/>	Test software	Tonscend	TS+		V5.0.0.0	
Conducted Emission Test For AC Power Port						
Used	Equipment	Manufacturer	Model No.	Serial No.	Last Cal.	Due. Date
<input checked="" type="checkbox"/>	LISN	R&S	ENV216	102509	Aug. 22, 2024	Aug. 21, 2025
<input checked="" type="checkbox"/>	EMI Receiver	R&S	ESR	102154	Aug. 22, 2024	Aug. 21, 2025
Software						
Used	Description	Manufacturer	Name		Version	
<input checked="" type="checkbox"/>	Test software	EZ	EZ-EMC		EMEC-3A1	
Other Instrument						
Used	Equipment	Manufacturer	Model No.	Serial No.	Last Cal.	Due. Date
<input checked="" type="checkbox"/>	Temperature & Humidity	Temperature	HTC-1	/	Sep. 04, 2024	Sep. 03, 2025

8. On Time and Duty Cycle

8.1. Block diagram of test setup

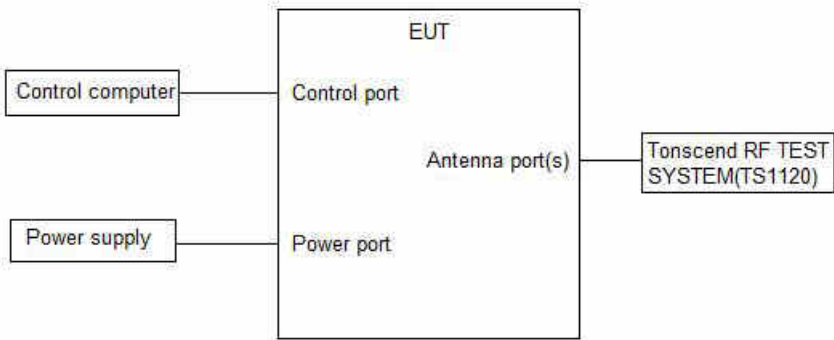

8.2. Limits

None; for reporting purposes only

8.3. Procedure

KDB 558074 Zero-Span Spectrum Analyzer Method

8.4. Results

Test Mode	Ant.	Freq. (MHz)	ON Time (ms)	Period (ms)	Duty Cycle (%)	Duty Cycle Factor(dB)
BLE_1M	Ant1	2402	2.12	2.50	84.80	0.72
		2440	2.13	2.50	85.20	0.70
		2480	2.12	2.50	84.80	0.72
BLE_2M	Ant1	2402	1.06	1.87	56.68	2.47
		2440	1.07	1.88	56.91	2.45
		2480	1.07	1.88	56.91	2.45

Note: Duty Cycle Correction Factor = 10log(1/x).

Where: x is Duty Cycle(Linear)

Where: T is On Time (transmit duration)

If that calculated VBW is not available on the analyzer, then the next higher value should be used.

8.5. Original test data

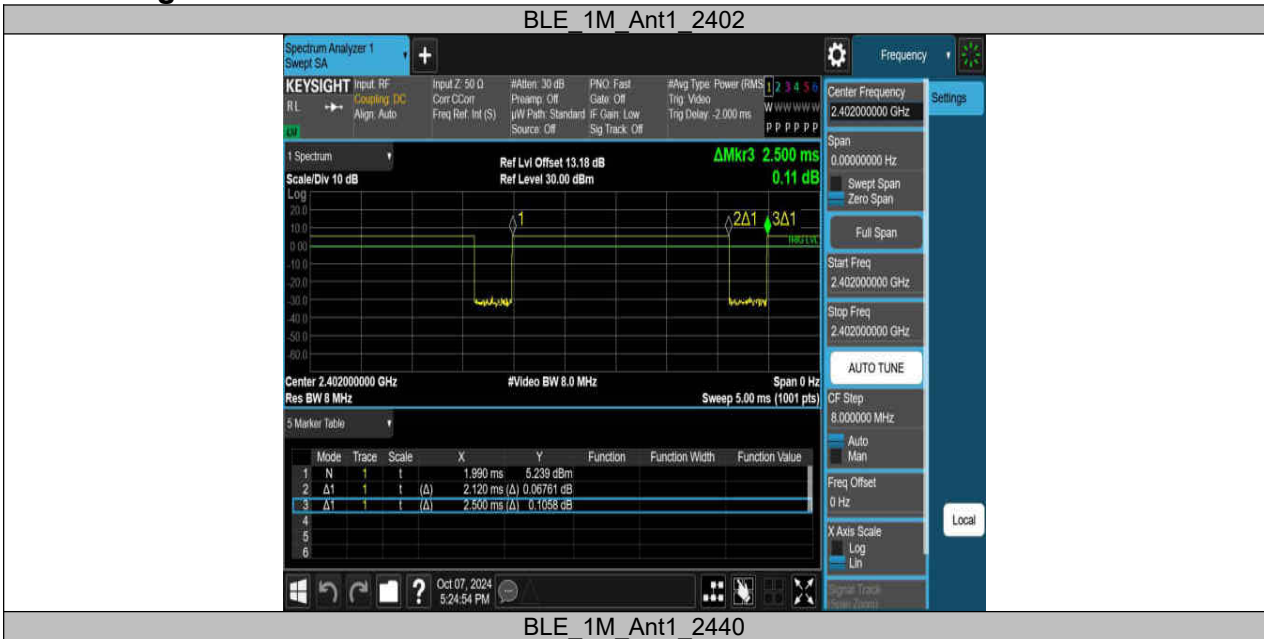

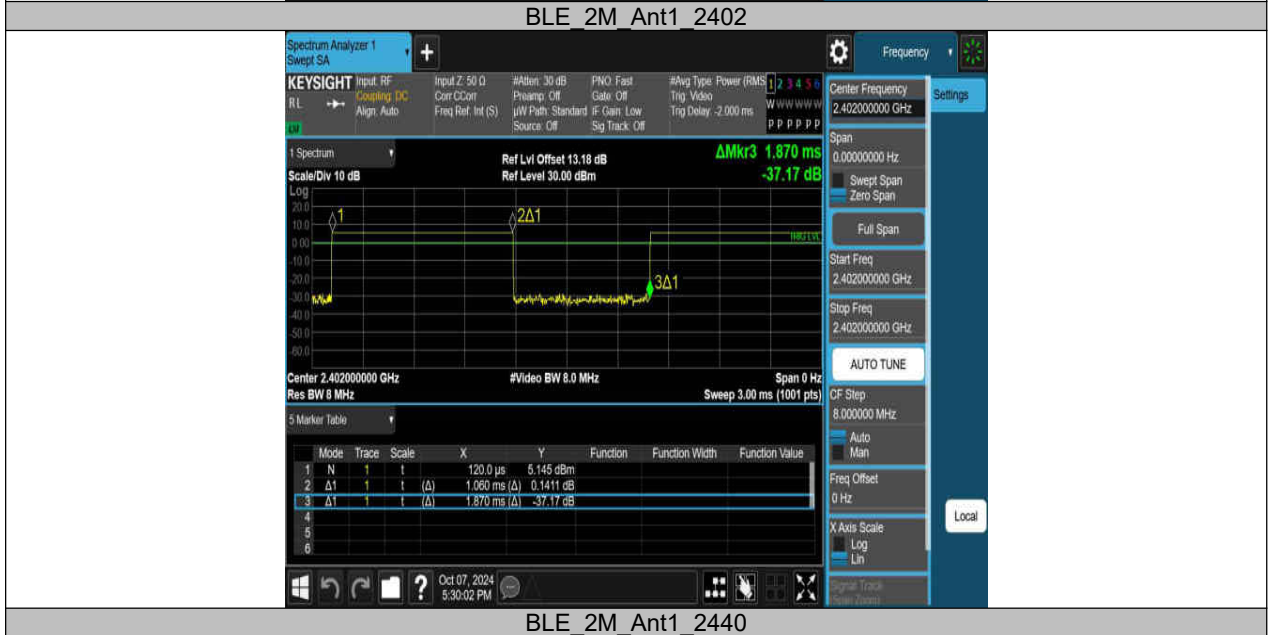



BLE 2M Ant1 2480



9. 6 dB DTS Bandwidth and 99 % Bandwidth

9.1. Block diagram of test setup

Same as section 8.1

9.2. Limits

CFR 47FCC Part15 (15.247) Subpart C ISED RSS-247 ISSUE 3			
Section	Test Item	Limit	Frequency Range (MHz)
CFR 47 FCC 15.247(a)(2) ISED RSS-247 5.2 (a)	6 dB Bandwidth	>= 500 kHz	2400-2483.5
ISED RSS-Gen Clause 6.7	99 % Occupied Bandwidth	For reporting purposes only.	2400-2483.5

9.3. Test Procedure

Connect the UUT to the spectrum analyzer and use the following settings:

Center Frequency	The center frequency of the channel under test
Detector	Peak
RBW	For 6 dB Bandwidth :100 kHz For 99 % Occupied Bandwidth :1 % to 5 % of the occupied bandwidth
VBW	For 6 dB Bandwidth : $\geq 3 \times$ RBW For 99 % Occupied Bandwidth : $\geq 3 \times$ RBW
Trace	Max hold
Sweep	Auto couple

Allow the trace to stabilize and measure the maximum width of the emission that is constrained by the frequencies associated with the two outermost amplitude points (upper and lower frequencies) that are attenuated by 6 dB/99 % relative to the maximum level measured in the fundamental emission.

9.4. Results

Test Mode	Ant.	Freq. (MHz)	DTS BW (MHz)	FL (MHz)	FH (MHz)	Limit (MHz)	Verdict
BLE_1M	Ant1	2402	0.676	2401.628	2402.304	0.5	PASS
		2440	0.652	2439.648	2440.300	0.5	PASS
		2480	0.664	2479.636	2480.300	0.5	PASS
BLE_2M	Ant1	2402	1.260	2401.308	2402.568	0.5	PASS
		2440	1.260	2439.300	2440.560	0.5	PASS
		2480	1.244	2479.312	2480.556	0.5	PASS

Test Mode	Antenna	Frequency (MHz)	OCB (MHz)	FL(MHz)	FH(MHz)	Limit(MHz)	Verdict
BLE_1M	Ant1	2402	1.0286	2401.4587	2402.4873	---	---
		2440	1.0255	2439.4580	2440.4835	---	---
		2480	1.0262	2479.4568	2480.4830	---	---
BLE_2M	Ant1	2402	2.0521	2400.9631	2403.0152	---	---
		2440	2.0442	2438.9625	2441.0067	---	---
		2480	2.0545	2478.9614	2481.0159	---	---

9.5. Original test data

6 dB bandwidth:



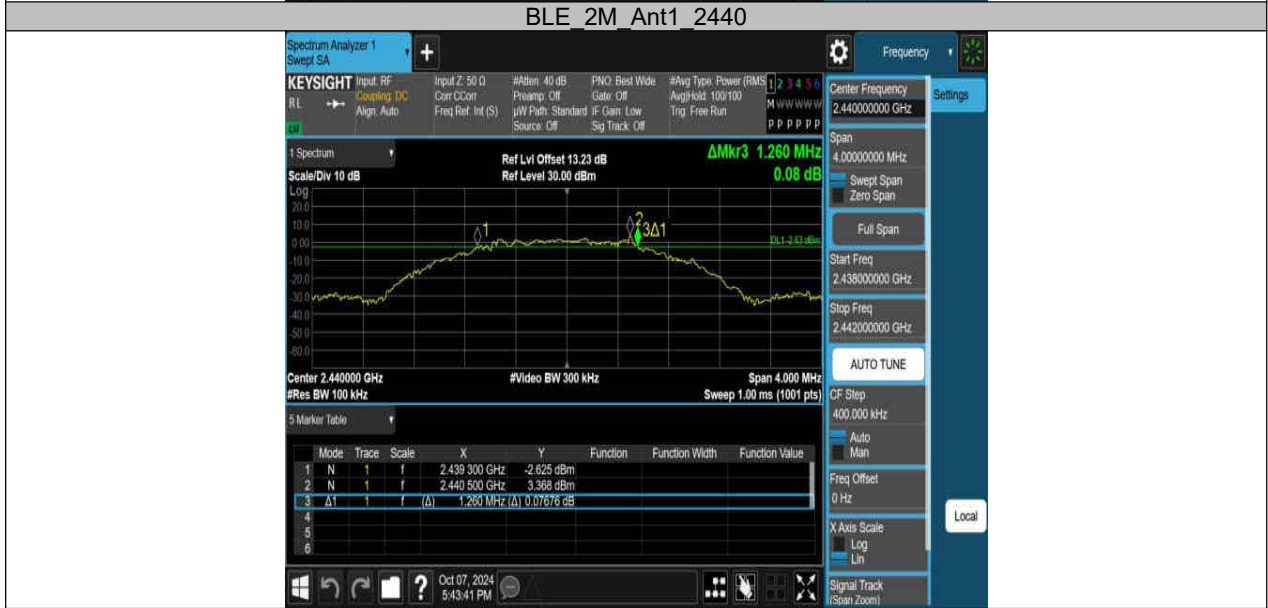

99% bandwidth



BLE 2M Ant1 2402



10. Peak Conducted Output Power

10.1. Block diagram of test setup

Same as section 8.1

10.2. Limits

CFR 47 FCC Part15 (15.247) Subpart C ISED RSS-247 ISSUE 3			
Section	Test Item	Limit	Frequency Range (MHz)
CFR 47 FCC 15.247(b)(3) ISED RSS-247 5.4 (d)	Peak Output Power	1 watt or 30 dBm	2400 - 2483.5

10.3. Test Procedure

Connect EUT's antenna output to spectrum analyzer by RF cable.

99% Bandwidth set the spectrum analyzer as follows:

RBW:	30 kHz
VBW:	100 kHz
Detector Mode:	Peak
Sweep time:	auto
Trace mode	Max hold

6 dB Bandwidth set the spectrum analyzer as follows:

RBW:	100 kHz
VBW:	300 kHz
Detector Mode:	Peak
Sweep time:	auto
Trace mode	Max hold

Allow the trace to stabilize, measure the 6 dB and 99% bandwidth of signal.

10.4. Results

Test Mode	Ant.	Freq (MHz)	Conducted Peak Power (dBm)	Conducted Limit (dBm)	EIRP (dBm)	EIRP Limit (dBm)	Verdict
BLE_1M	Ant1	2402	5.46	≤30	9.52	≤36	PASS
		2440	5.41	≤30	9.47	≤36	PASS
		2480	5.03	≤30	9.09	≤36	PASS
BLE_2M	Ant1	2402	5.43	≤30	9.49	≤36	PASS
		2440	5.31	≤30	9.37	≤36	PASS
		2480	4.92	≤30	8.98	≤36	PASS

10.5. Original test data

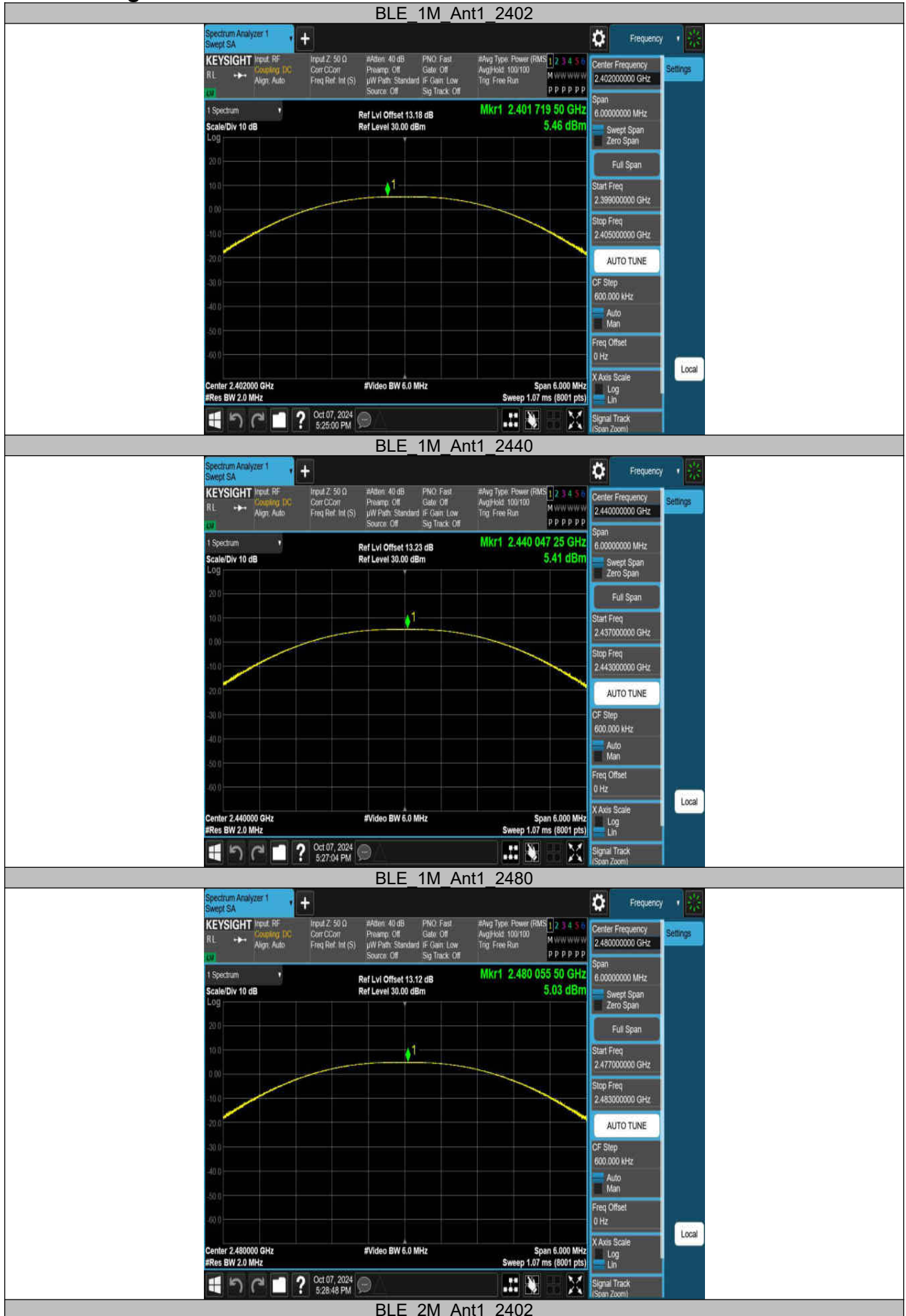

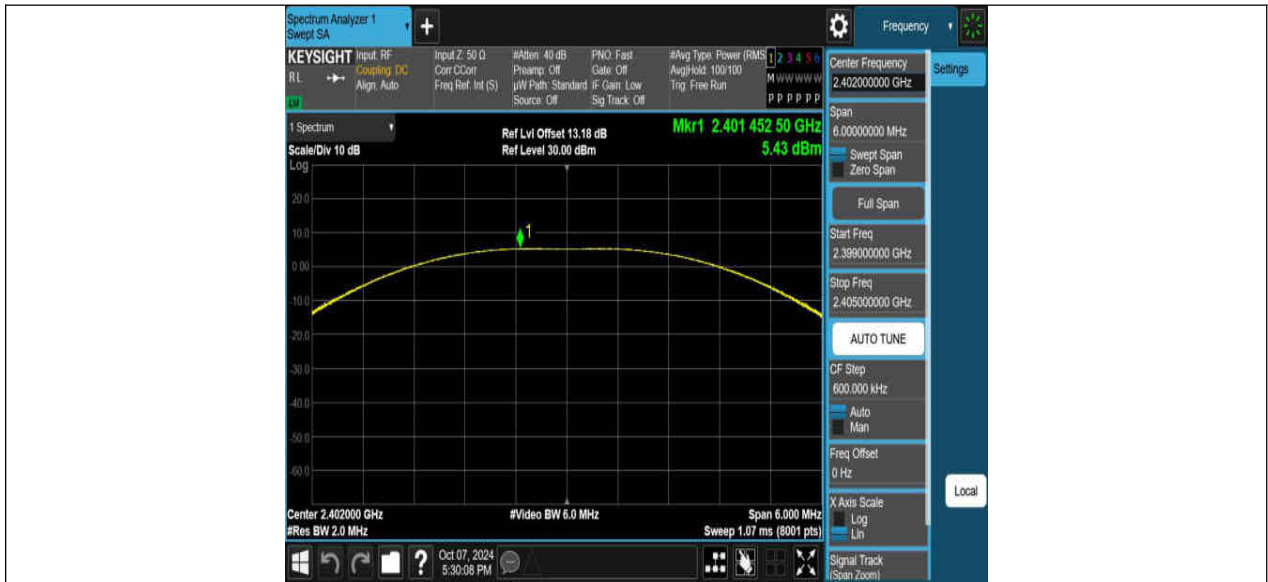

11. Power Spectral Density

11.1. Block diagram of test setup

Same as section 8.1

11.2. Limits

CFR 47 FCC Part15 (15.247) Subpart C ISED RSS-247 ISSUE 3			
Section	Test Item	Limit	Frequency Range (MHz)
CFR 47 FCC §15.247 (e) ISED RSS-247 5.2 (b)	Power Spectral Density	8 dBm in any 3 kHz band	2400 - 2483.5

11.3. Test Procedure

Connect the UUT to the spectrum analyzer and use the following settings:

Center Frequency	The center frequency of the channel under test
Detector	Peak
RBW	$3 \text{ kHz} \leq \text{RBW} \leq 100 \text{ kHz}$
VBW	$\geq 3 \times \text{RBW}$
Span	1.5 x DTS bandwidth
Trace	Max hold
Sweep time	Auto couple.

Allow trace to fully stabilize and use the peak marker function to determine the maximum amplitude level within the RBW.

If measured value exceeds limit, reduce RBW (no less than 3 kHz) and repeat.

11.4. Results

Test Mode	Ant.	Freq. (MHz)	Result (dBm/3kHz)	Limit (dBm/3kHz)	Verdict
BLE_1M	Ant1	2402	-11.40	≤ 8.00	PASS
		2440	-11.44	≤ 8.00	PASS
		2480	-11.91	≤ 8.00	PASS
BLE_2M	Ant1	2402	-14.37	≤ 8.00	PASS
		2440	-14.35	≤ 8.00	PASS
		2480	-14.80	≤ 8.00	PASS

11.5. Original test data





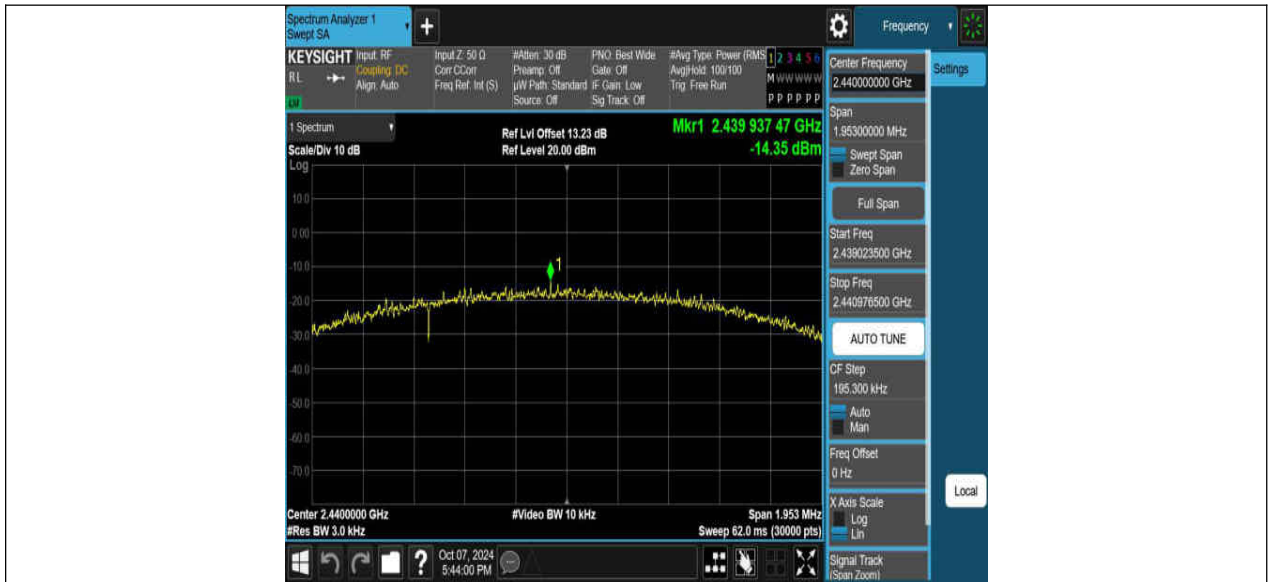

BLE 2M Ant1 2480

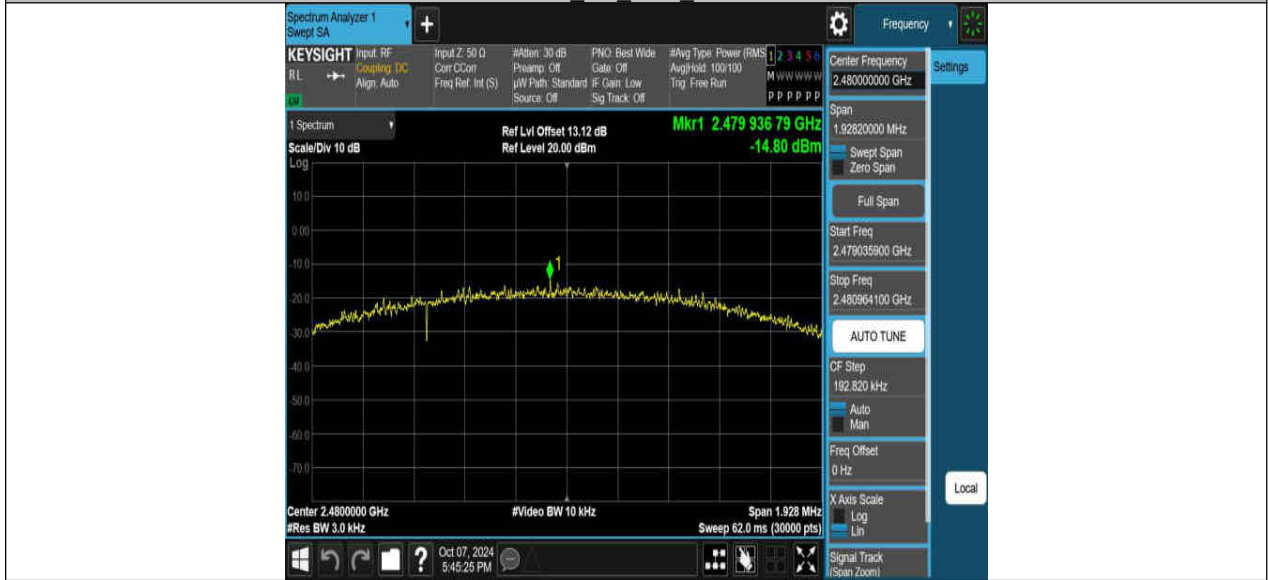

12. Conducted Bandedge and Spurious Emissions

12.1. Block diagram of test setup

Same as section 8.1

12.2. Limits

CFR 47 FCC Part15 (15.247) Subpart C ISED RSS-247 ISSUE 3		
Section	Test Item	Limit
CFR 47 FCC §15.247 (d) ISED RSS-247 5.5	Conducted Band edge and Spurious Emissions	at least 20 dB below that in the 100 kHz bandwidth within the band that contains the highest level of the desired power

12.3. Test Procedure

Center Frequency	The center frequency of the channel under test
Detector	Peak
RBW	100 kHz
VBW	$\geq 3 \times \text{RBW}$
Span	$\geq 1.5 \times \text{DTS bandwidth}$
Trace	Max hold
Sweep time	Auto couple

Connect the UUT to the spectrum analyzer and use the following settings:

Use the peak marker function to determine the maximum peak power level to establish the reference level.

Span	Set the center frequency and span to encompass frequency range to be measured
Detector	Peak
RBW	100 kHz
VBW	$\geq 3 \times \text{RBW}$
measurement points	$\geq \text{span}/\text{RBW}$
Trace	Max hold
Sweep time	Auto couple

Use the peak marker function to determine the maximum amplitude level.

12.4. Results

Band edge

Test Mode	Ant.	Ch Name	Freq. (MHz)	Ref Level (dBm)	Result (dBm)	Limit (dBm)	Verdict
BLE_1M	Ant1	Low	2402	4.23	-46.17	≤ -15.77	PASS
		High	2480	3.54	-45.24	≤ -16.46	PASS
BLE_2M	Ant1	Low	2402	2.16	-28.92	≤ -17.84	PASS
		High	2480	3.29	-46.21	≤ -16.71	PASS

Spurious Emissions

Test Mode	Ant.	Freq. (MHz)	Freq Range (MHz)	Ref Level (dBm)	Result (dBm)	Limit (dBm)	Verdict
BLE_1M	Ant1	2402	Reference	3.43	3.43	---	PASS
			30~1000	3.43	-57.81	≤-16.57	PASS
			1000~26500	3.43	-45.73	≤-16.57	PASS
		2440	Reference	3.64	3.64	---	PASS
			30~1000	3.64	-58.45	≤-16.36	PASS
			1000~26500	3.64	-44.11	≤-16.36	PASS
		2480	Reference	3.09	3.09	---	PASS
			30~1000	3.09	-58.08	≤-16.91	PASS
			1000~26500	3.09	-43.72	≤-16.91	PASS
BLE_2M	Ant1	2402	Reference	1.80	1.80	---	PASS
			30~1000	1.80	-59.15	≤-18.2	PASS
			1000~26500	1.80	-47.08	≤-18.2	PASS
		2440	Reference	1.95	1.95	---	PASS
			30~1000	1.95	-58.83	≤-18.05	PASS
			1000~26500	1.95	-46.79	≤-18.05	PASS
		2480	Reference	1.03	1.03	---	PASS
			30~1000	1.03	-58.46	≤-18.97	PASS
			1000~26500	1.03	-48.93	≤-18.97	PASS

12.5. Original test data

Band edge:

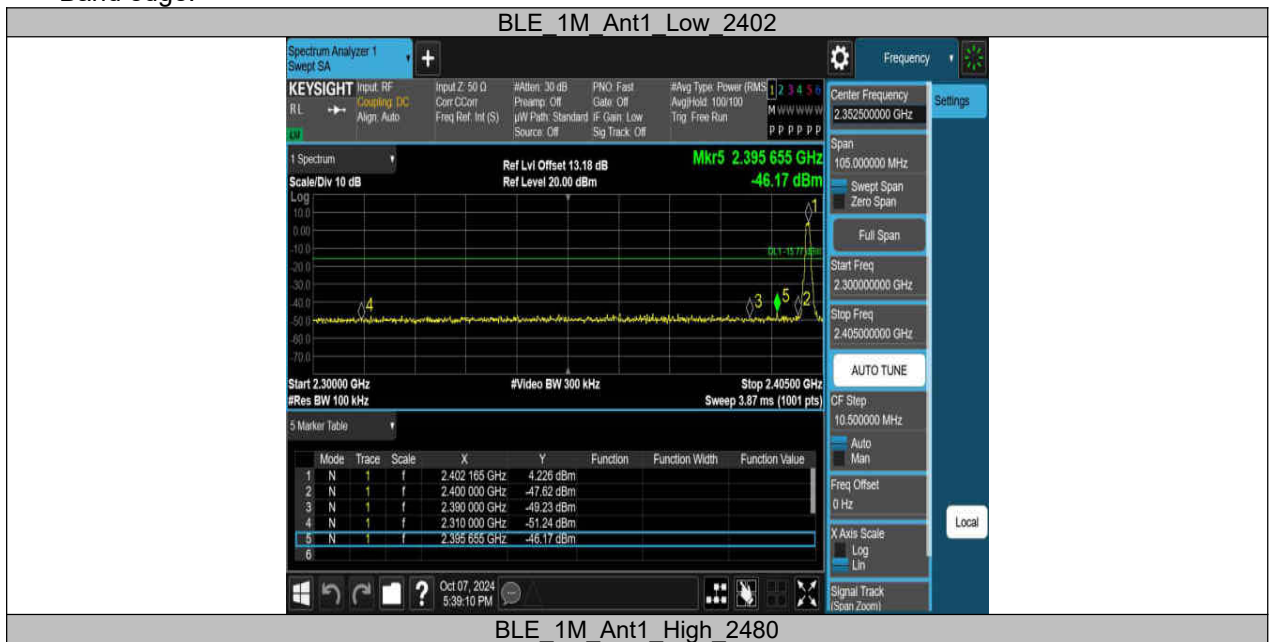

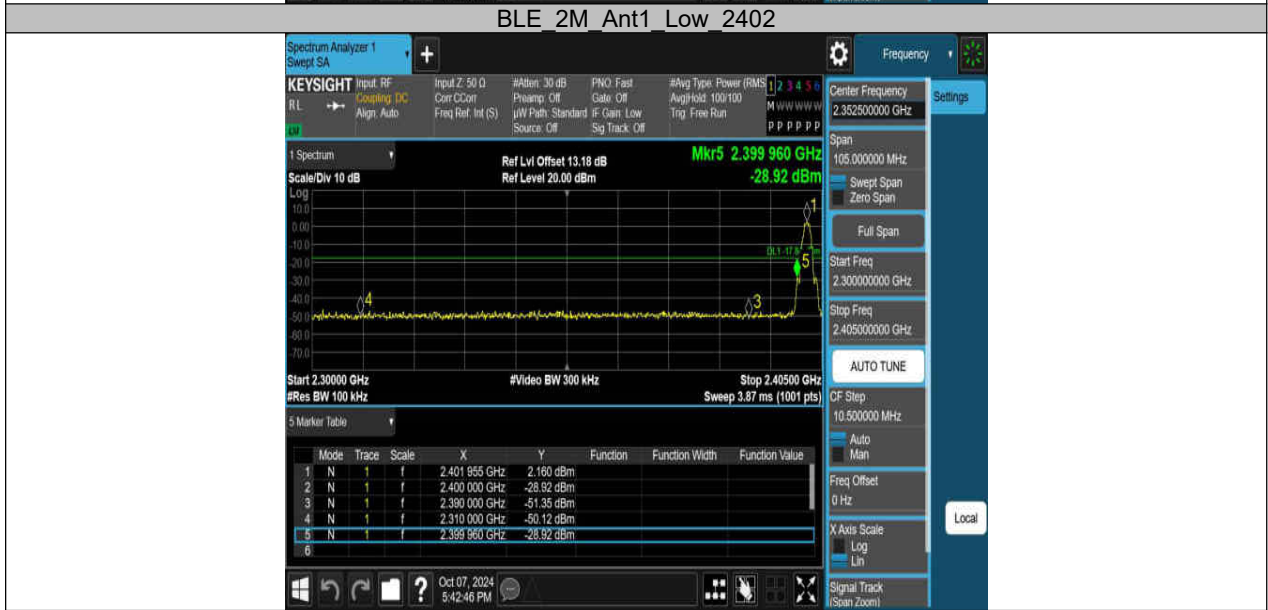

Spurious Emissions:

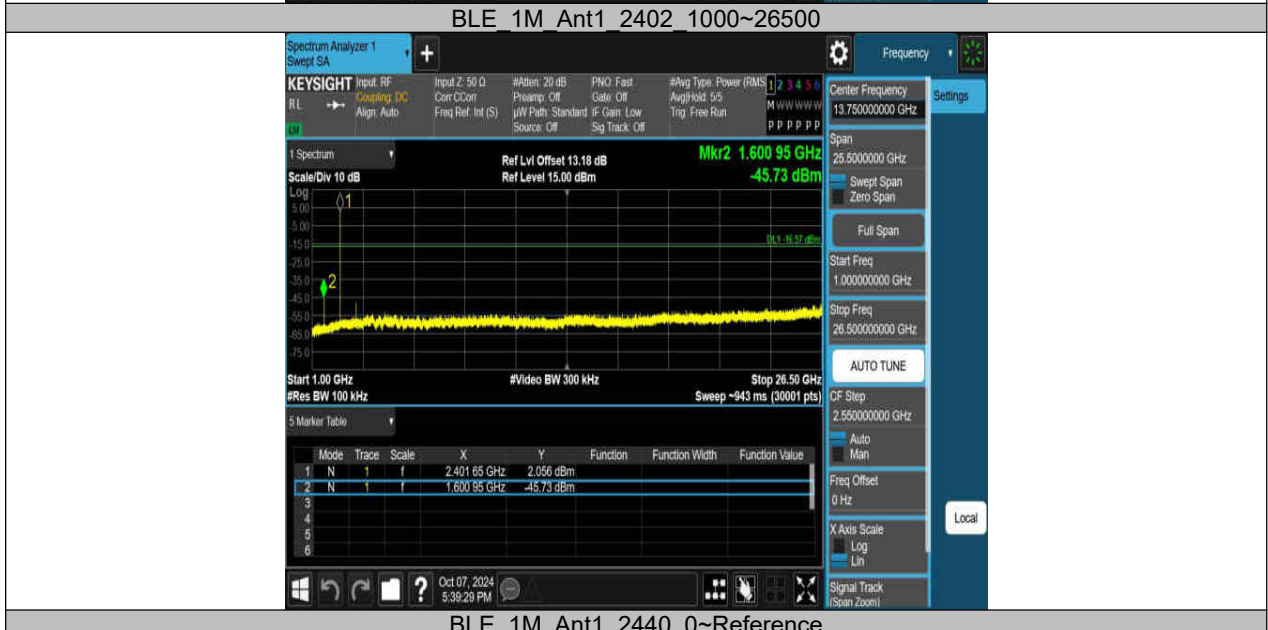
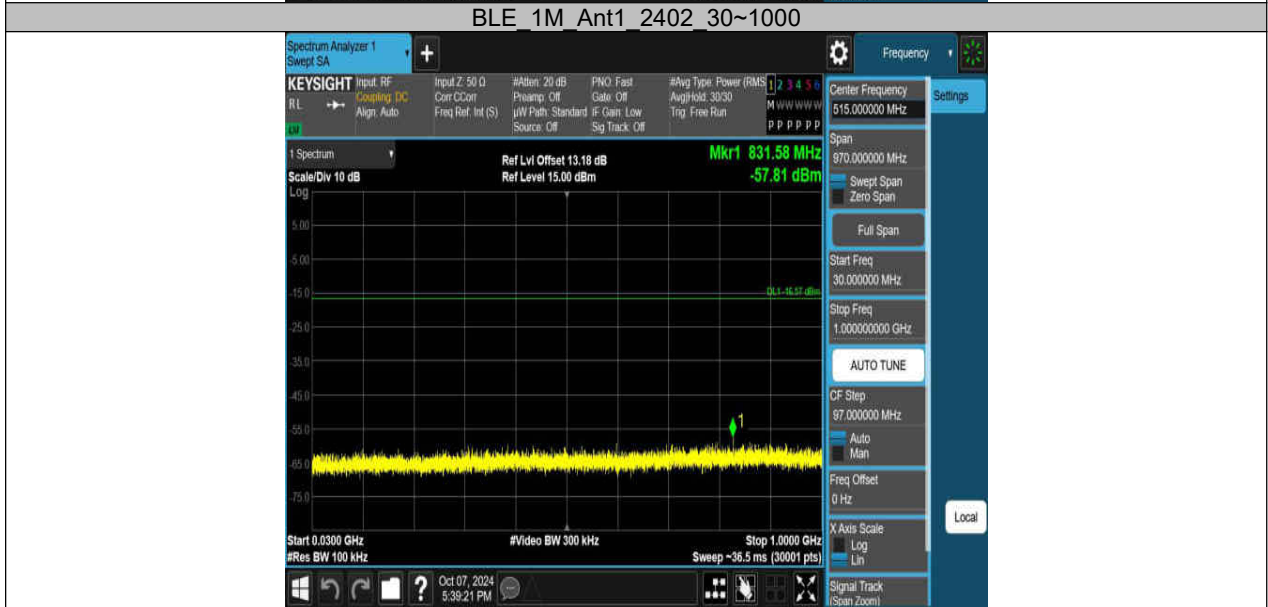



BLE 1M Ant1 2440 30~1000



BLE 1M Ant1 2440 1000~26500



BLE 1M Ant1 2480 0~Reference



BLE 1M Ant1 2480 30~1000



BLE 1M Ant1 2480 1000~26500



BLE 2M Ant1 2402 0~Reference

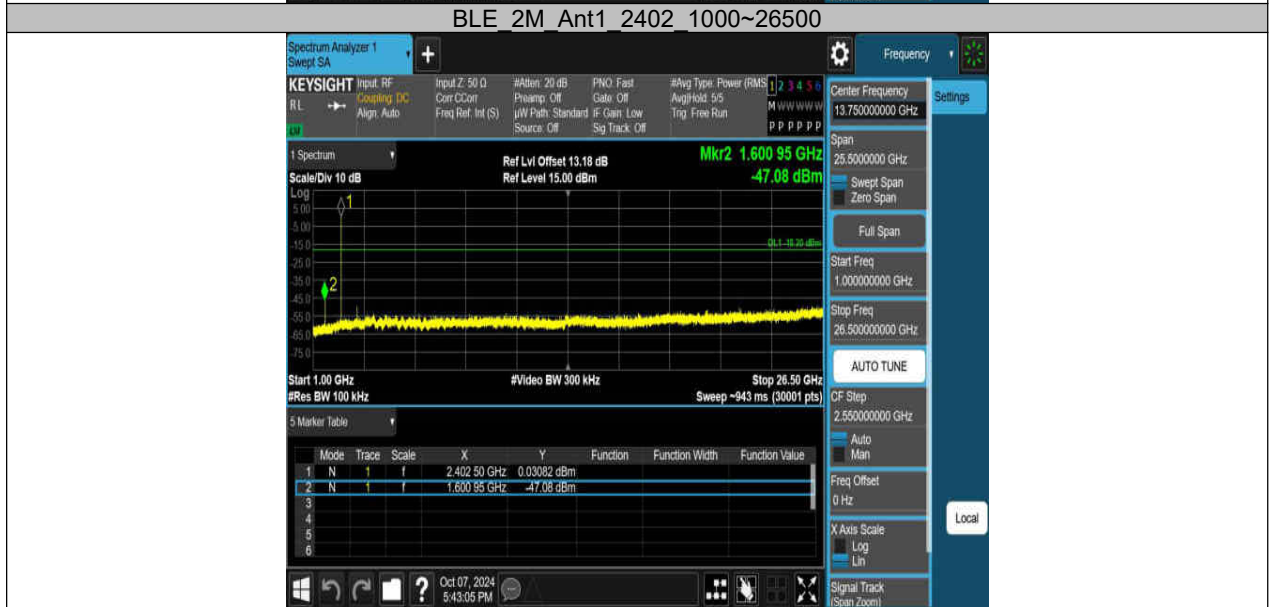
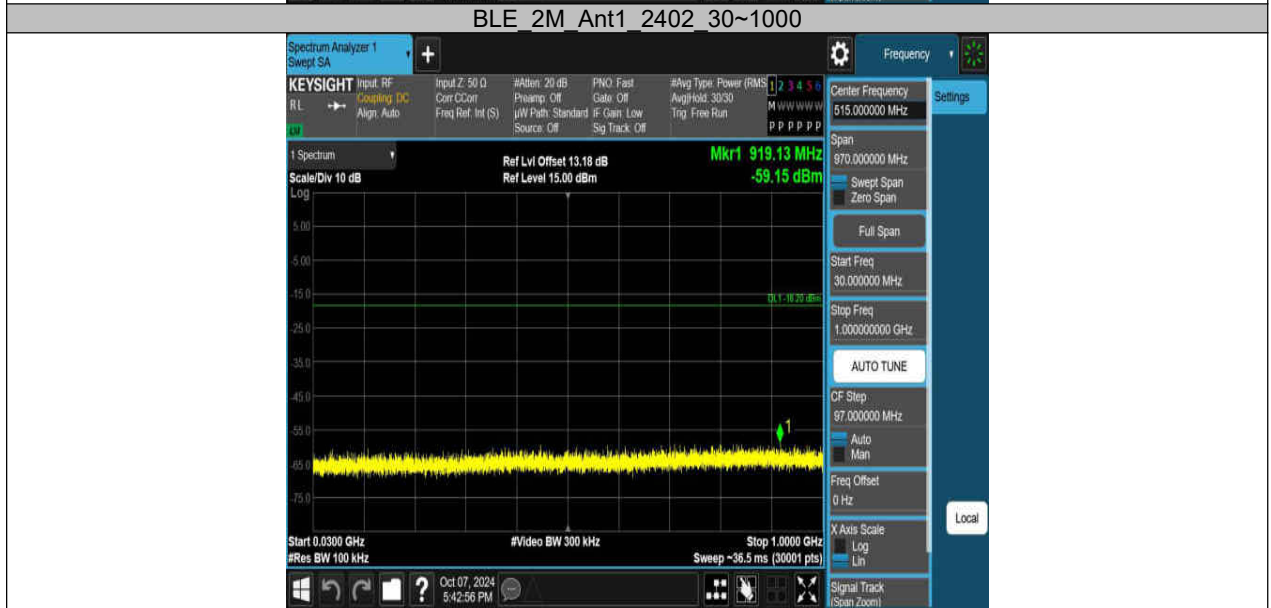



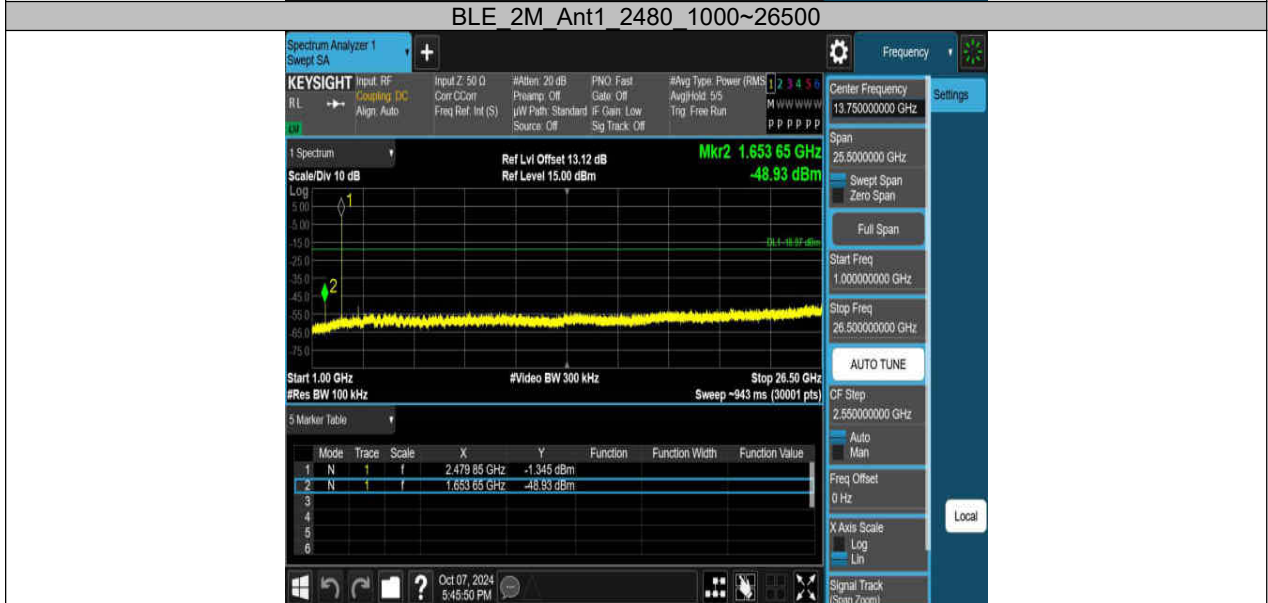
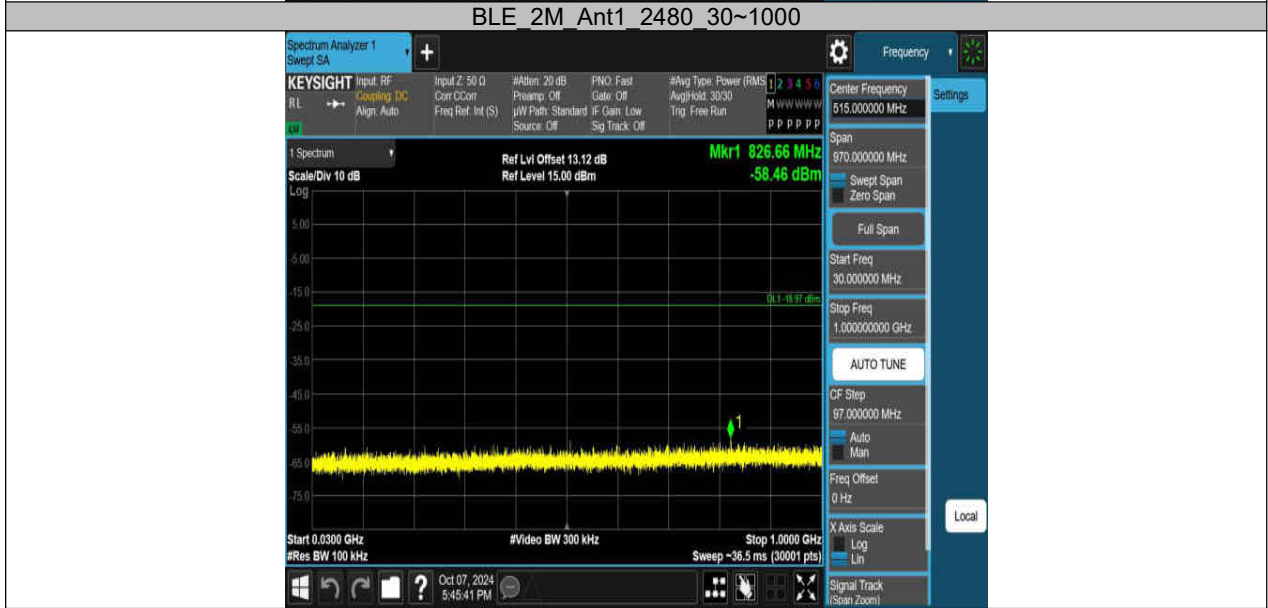

13. Radiated Emission

13.1. Block diagram of test setup

In 3m Anechoic Chamber, test setup diagram for 9kHz - 30MHz:

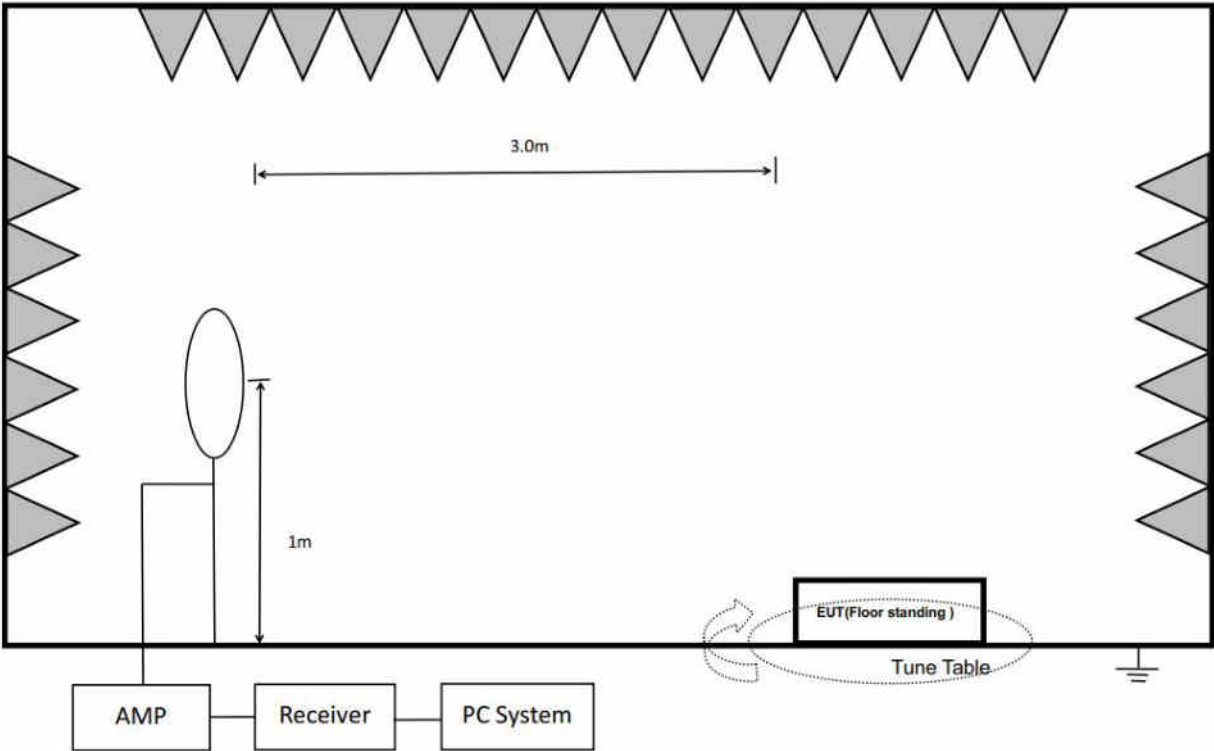

In 3m Anechoic Chamber, test setup diagram for 30 MHz - 1 GHz:

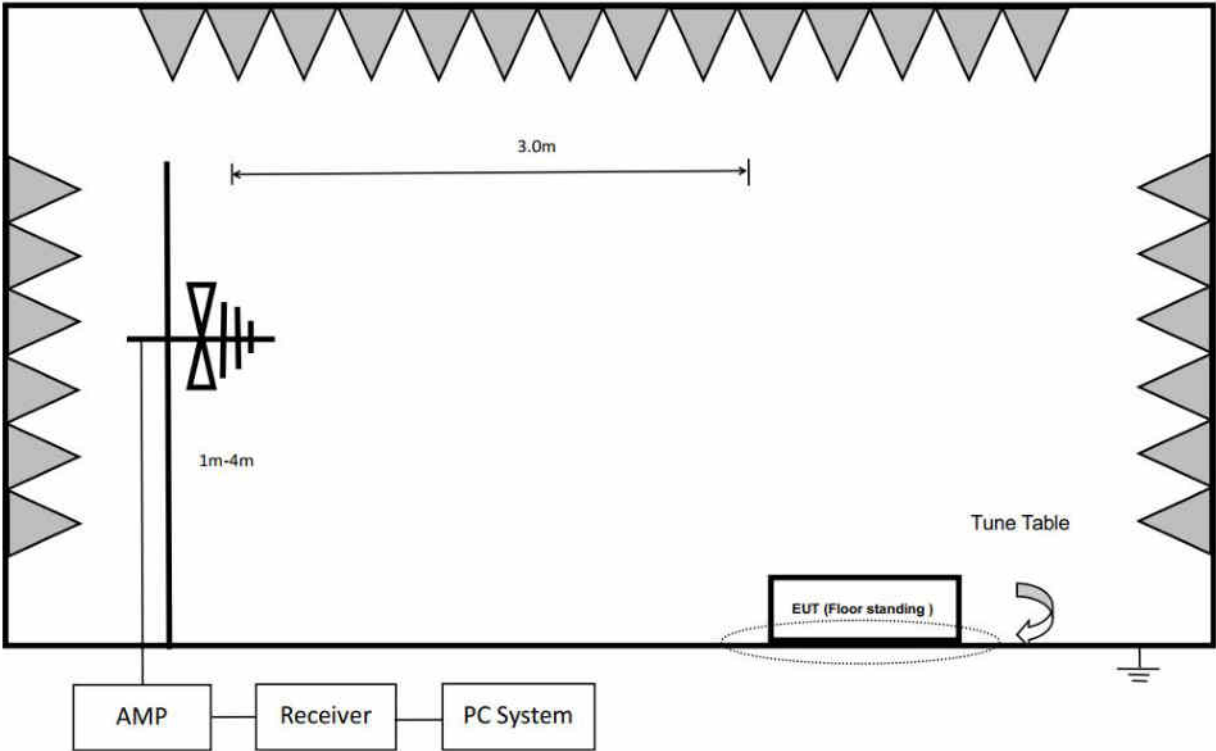

In 3m Anechoic Chamber, test setup diagram for frequency above 1 GHz:

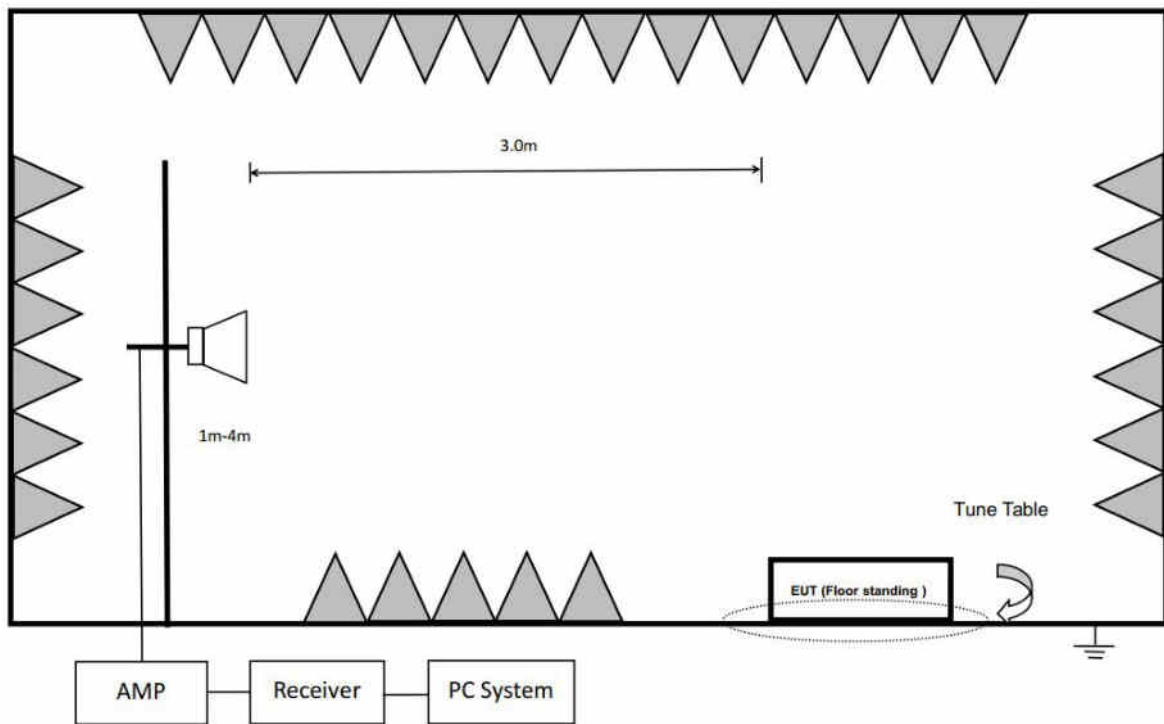

Note: For harmonic emissions test an appropriate high pass filter was inserted in the input port of AMP.

13.2. Limit

(1) FCC 15.205 Restricted frequency band

MHz	MHz	MHz	GHz
0.090-0.110	16.42-16.423	399.9-410	4.5-5.15
10.495-0.505	16.69475-16.69525	608-614	5.35-5.46
2.1735-2.1905	16.80425-16.80475	960-1240	7.25-7.75
4.125-4.128	25.5-25.67	1300-1427	8.025-8.5
4.1772&4.17775	37.5-38.25	1435-1626.5	9.0-9.2
4.2072&4.20775	73-74.6	1645.5-1646.5	9.3-9.5
6.215-6.218	74.8-75.2	1660-1710	10.6-12.7
6.26775-6.26825	108-121.94	1718.8-1722.2	13.25-13.4
6.31175-6.31225	123-138	2200-2300	14.47-14.5
8.291-8.294	149.9-150.05	2310-2390	15.35-16.2
8.362-8.366	156.52475-156.52525	2483.5-2500	17.7-21.4
8.37625-8.38675	156.7-156.9	2690-2900	22.01-23.12
8.41425-8.41475	162.0125-167.17	3260-3267	23.6-24.0
12.29-12.293	167.72-173.2	3332-3339	31.2-31.8
12.51975-12.52025	240-285	3345.8-3358	36.43-36.5
12.57675-12.57725	322-335.4	3600-4400	(²)
13.36-13.41			

¹Until February 1, 1999, this restricted band shall be 0.490-0.510 MHz.

²Above 38.6

(2) FCC 15.209 Limit.

Frequency MHz	Distance Meters	Field Strengths Limit	
		$\mu\text{V}/\text{m}$	$\text{dB}(\mu\text{V})/\text{m}$
0.009 ~ 0.490	300	2400/F(kHz)	67.6-20log(F)
0.490 ~ 1.705	30	24000/F(kHz)	87.6-20log(F)
1.705 ~ 30.0	30	30	29.54
30 ~ 88	3	100	40.0
88 ~ 216	3	150	43.5
216~960	3	200	46.0
960~1000	3	500	54.0
Above 1000	3	74.0 $\text{dB}(\mu\text{V})/\text{m}$ (Peak) 54.0 $\text{dB}(\mu\text{V})/\text{m}$ (Average)	

Note: (1) At frequencies at or above 30 MHz, measurements may be performed at a distance other than what is specified provided: measurements are not made in the near field except where it can be shown that near field measurements are appropriate due to the characteristics of the device; and it can be demonstrated that the signal levels needed to be measured at the distance employed can be detected by the measurement equipment. Measurements shall not be performed at a distance greater than 30 meters unless it can be further demonstrated that measurements at a distance of 30 meters or less are impractical. When performing measurements at a distance other than that specified, the results shall be extrapolated to the specified distance using an extrapolation factor of 20 dB/decade (inverse linear-distance for field strength measurements; inverse-linear-distance-squared for power density measurements).

(2) At frequencies below 30 MHz, measurements may be performed at a distance closer than that specified in the regulations; however, an attempt should be made to avoid making measurements in the near field. Pending the development of an appropriate measurement procedure for measurements performed below 30 MHz, when performing measurements at a closer distance than specified, the results shall be extrapolated to the specified distance by either making measurements at a minimum of two distances on at least one radial to determine the proper extrapolation factor or by using the square of an inverse linear distance extrapolation factor (40 dB/decade). This paragraph (f) shall not apply to Access BPL devices operating below 30 MHz.

About Restricted bands of operation please refer to RSS-Gen section 8.10 and FCC § 15.205(a),

13.3. Test Procedure

Below 30 MHz:

The setting of the spectrum Analyzer

RBW	300 Hz (From 9 kHz to 0.15 MHz)/ 10 kHz (From 0.15 MHz to 30 MHz)
VBW	1 kHz (From 9 kHz to 0.15 MHz)/ 30 kHz (From 0.15 MHz to 30 MHz)
Sweep	Auto
Trace	Max hold

1. The testing follows the guidelines in ANSI C63.10-2013

2. The EUT was arranged to its worst case and then turntable (from 0 degree to 360 degrees) to find the maximum reading. A pre-amp and a high pass filter are used for the test in order to get better signal level. Both Horizontal, Face-on and Face-off polarizations of the antenna are set to make the measurement.

3. The EUT and all cables shall be insulated, if required, from the ground plane by up to 12mm of insulating material.

4. The EUT was set 3 meters from the interference receiving antenna, which was mounted on the top of 1 meter height antenna tower.

5. The radiated emission limits are based on measurements employing a CISPR quasi-peak detector except for the frequency bands 9-90 kHz, 110-490 kHz and above 1000 MHz. Radiated emission limits in these three bands are based on measurements employing an average detector.

6. For measurement below 1 GHz, the initial step in collecting conducted emission data is a spectrum analyzer peak detector mode pre-scanning the measurement frequency range. Significant peaks are

then marked and then Quasi Peak detector mode re-measured. If the emission level of the EUT measured by the peak detector is 3 dB lower than the applicable limit, the peak emission level will be reported. Otherwise, the emission measurement will be repeated using the quasi-peak detector and reported.

7. Although these tests were performed other than open field site, adequate comparison measurements were confirmed against 30m open field site. Therefore, sufficient tests were made to demonstrate that the alternative site produces results that correlate with the ones of tests made in an open field site based on KDB 414788.

Below 1 GHz and above 30 MHz:

The setting of the spectrum Analyzer

RBW	100 kHz
VBW	300 kHz
Sweep	Auto
Trace	Max hold

1. The testing follows the guidelines in ANSI C63.10-2013.

2. The EUT was arranged to its worst case and then tune the antenna tower (from 1 m to 4 m) and turntable (from 0 degree to 360 degrees) to find the maximum reading. A pre-amp and a high pass filter are used for the test in order to get better signal level. Both horizontal and vertical polarizations of the antenna are set to make the measurement.

3. The EUT and all cables shall be insulated, if required, from the ground plane by up to 12mm of insulating material.

4. The EUT was set 3 meters from the interference receiving antenna, which was mounted on the top of a variable height antenna tower.

5. For measurement below 1GHz, the initial step in collecting conducted emission data is a spectrum analyzer peak detector mode pre-scanning the measurement frequency range. Significant peaks are then marked and then Quasi Peak detector mode re-measured. If the emission level of the EUT measured by the peak detector is 3 dB lower than the applicable limit, the peak emission level will be reported. Otherwise, the emission measurement will be repeated using the quasi-peak detector and reported.

Above 1 GHz:

RBW	1 MHz
VBW	PEAK: 3 MHz AVG: see note 6
Sweep	Auto
Detector	Peak
Trace	Max hold

1. The testing follows the guidelines in ANSI C63.10-2013.

2. The EUT was arranged to its worst case and then tune the antenna tower (from 1 m to 4 m) and turntable (from 0 degree to 360 degrees) to find the maximum reading. A pre-amp and a high pass filter are used for the test in order to get better signal level. Both horizontal and vertical polarizations of the antenna are set to make the measurement.

3. The EUT and all cables shall be insulated, if required, from the ground plane by up to 12mm of insulating material.

4. The EUT was set 3 meters from the interference receiving antenna, which was mounted on the top of a variable height antenna tower.

5. For measurement above 1GHz, the emission measurement will be measured by the peak detector. This peak level, once corrected, must comply with the limit specified in Section 15.209.

6. For measurements above 1 GHz the resolution bandwidth is set to 1 MHz, then the video bandwidth is set to 3 MHz for peak measurements and 1 MHz resolution bandwidth with 1/T video bandwidth with peak detector for AVG measurements. For the Duty Cycle please refer to clause 8.1.ON TIME AND DUTY CYCLE.

7. Restriction band: Investigated frequency range from 2310 MHz to 2410 MHz and 2470MHz to 2500 MHz.

All restriction band should comply with 15.209, other emission should be at least 20 dB below the fundamental.

Note 1: For all radiated test, EUT in each of three orthogonal axis emissions had been tested, but only the worst case (X axis) data recorded in the report.

Note 2: The EUT does not support simultaneous transmission.

Note 3: The EUT was fully exercised with external accessories during the test. In the case of multiple accessory external ports, an external accessory shall be connected to one of each type of port.

13.4. Results

Pass. (See below detailed test result)

All the emissions except fundamental emission from 9 kHz to 25 GHz were comply with 15.209 limits.

Note1: According exploratory test, the emission levels are 20 dB below the limit detected from 9 kHz to 30 MHz, so the final test was performed with frequency range from 30 MHz to 26 GHz and recorded in below.

Note2: For emissions below 1 GHz, according exploratory explorer test, when change Tx mode and channel, have no distinct influence on emissions level, so for emissions below 1 GHz, the final test was only performed with EUT working in GFSK, Tx 2480 MHz mode.

Note3: For emissions above 1 GHz. If peak results comply with AV limit, AV Result is deemed to comply with AV limit.

13.5. Original test data

Below 1 GHz and above 30 MHz test data Refer to appendix A

Above 1 GHz test data Refer to appendix B

14. AC Power Line Conducted Emissions

14.1. Block diagram of test setup

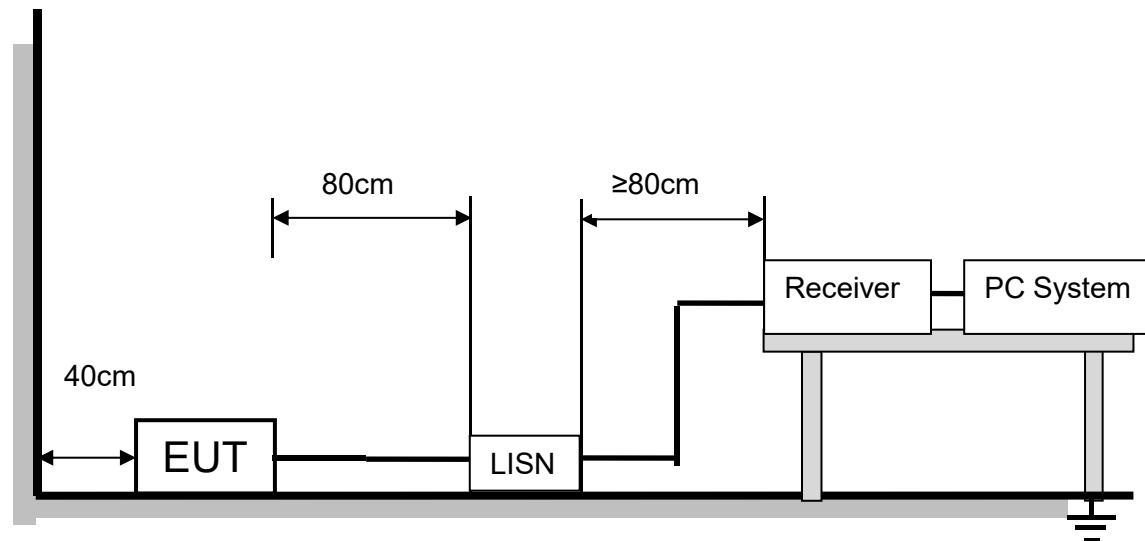

The EUT and all cables shall be insulated, if required, from the ground plane by up to 12mm of insulating material. The vertical conducting wall of shielding is located 40 cm to the rear of the EUT. The power line of the EUT is connected to the AC mains through an Artificial Mains Network (A.M.N.). A EMI Measurement Receiver (R&S Test Receiver ESR3) is used to test the emissions from both sides of AC line. According to the requirements in Section 6.2 of ANSI C63.10-2013. Conducted emissions from the EUT measured in the frequency range between 0.15 MHz and 30 MHz using CISPR Quasi-Peak and average detector mode. The bandwidth of EMI test receiver is set at 9 kHz.

The arrangement of the equipment is installed to meet the standards and operating in a manner, which tends to maximize its emission characteristics in a normal application.

14.2. Limits

Please refer to CFR 47 FCC § 15.207 (a) and ISED RSS-Gen Clause 8.8.

Frequency (MHz)	Quasi-peak	Average
0.15 -0.5	66 - 56 *	56 - 46 *
0.50 -5.0	56.00	46.00
5.0 -30.0	60.00	50.00

Note 1: * Decreasing linearly with logarithm of frequency.

Note 2: The lower limit shall apply at the transition frequencies.

14.3. Test procedure

The EUT and all cables shall be insulated, if required, from the ground plane by up to 12mm of insulating material.

Configuration EUT to simulate typical usage as described in clause 2.4 and test equipment as described in clause 10.2 of this report.

All I/O cables were positioned to simulate typical actual usage as per ANSI C63.10.

All support equipment power received from a second LISN.

Emissions were measured on each current carrying line of the EUT using an EMI Test Receiver connected to the LISN powering the EUT.

The Receiver scanned from 150 kHz to 30 MHz for emissions in each of the test modes.

During the above scans, the emissions were maximized by cable manipulation.

The test mode(s) described in clause 2.4 were scanned during the preliminary test.

After the preliminary scan, we found the test mode producing the highest emission level.

The EUT configuration and worse cable configuration of the above highest emission levels were recorded for reference of the final test.

EUT and support equipment were set up on the test bench as per the configuration with highest emission level in the preliminary test.

A scan was taken on both power lines, Neutral and Line, recording at least the six highest emissions.

Emission frequency and amplitude were recorded into a computer in which correction factors were used to calculate the emission level and compare reading to the applicable limit.

The test data of the worst-case condition(s) was recorded.

The bandwidth of test receiver is set at 9 kHz.

14.4. Test result

Pass. (See below detailed test result)

Note1: All emissions not reported below are too low against the prescribed limits.

Note2: Pre-test AC conducted emission at both voltage AC 120V/60Hz and AC 240V/50Hz, recorded worse case.

14.5. Original test data

AC Power Line Conducted Emission Test Data Refer to appendix C

15. Antenna Requirements

15.1. Limits

Please refer to FCC § 15.203

An intentional radiator shall be designed to ensure that no antenna other than that furnished by the responsible party shall be used with the device. The use of a permanently attached antenna or of an antenna that uses a unique coupling to the intentional radiator shall be considered sufficient to comply with the provisions of this section. The manufacturer may design the unit so that a broken antenna can be replaced by the user, but the use of a standard antenna jack or electrical connector is prohibited.

Please refer to FCC § 15.247(b)(4)

The conducted output power limit specified in paragraph (b) of this section is based on the use of antennas with directional gains that do not exceed 6 dBi. Except as shown in paragraph (c) of this section, if transmitting antennas of directional gain greater than 6 dBi are used, the conducted output power from the intentional radiator shall be reduced below the stated values in paragraphs (b)(1), (b)(2), and (b)(3) of this section, as appropriate, by the amount in dB that the directional gain of the antenna exceeds 6 dBi.

15.2. Result

The antenna used for this product is SMA antenna and that no antenna other than that furnished by the responsible party shall be used with the device, the maximum peak gain of the transmit antenna is 4.06 dBi

APPENDIX A – Radiated Emission Below 1GHz Test Data Test Report

Project Information			
Customer:			
EUT:			
Model:	CH65GC	SN:	
Mode:	BLE1M_2480	Voltage:	AC120V/60Hz
Environment:	Temp: 25°C; Humi:60%	Engineer:	Fly Liao
Remark:	power set:default		
Test Standard: FCC PART 15 C			

Start of Test:2024-10-13 16:42:39

Test Graph



Final Data List									
NO.	Frequency (MHz)	Factor (dB/m)	QP Value (dBµV/m)	QP Limit (dBµV/m)	QP Margin (dB)	Height (cm)	Angle (°)	Polarity	Verdict
1	70.1660	17.67	22.37	40.00	17.63	100	65	Horizontal	PASS
2	132.4525	16.90	28.66	43.50	14.84	100	346	Horizontal	PASS
3	186.9774	19.13	26.50	43.50	17.00	100	48	Horizontal	PASS
4	221.1282	21.13	29.10	46.00	16.90	100	29	Horizontal	PASS
5	497.4395	27.86	35.16	46.00	10.84	100	296	Horizontal	PASS
6	678.8658	30.94	35.55	46.00	10.45	100	277	Horizontal	PASS

Test Report

Project Information			
Customer:			
EUT:			
Model:	CH65GC	SN:	
Mode:	BLE1M_2480	Voltage:	230V/50Hz
Environment:	Temp: 25°C; Humi:60%	Engineer:	Fly Liao
Remark:	power set:default		
Test Standard: FCC PART 15 C			

Start of Test:2024-10-13 16:43:25

Test Graph

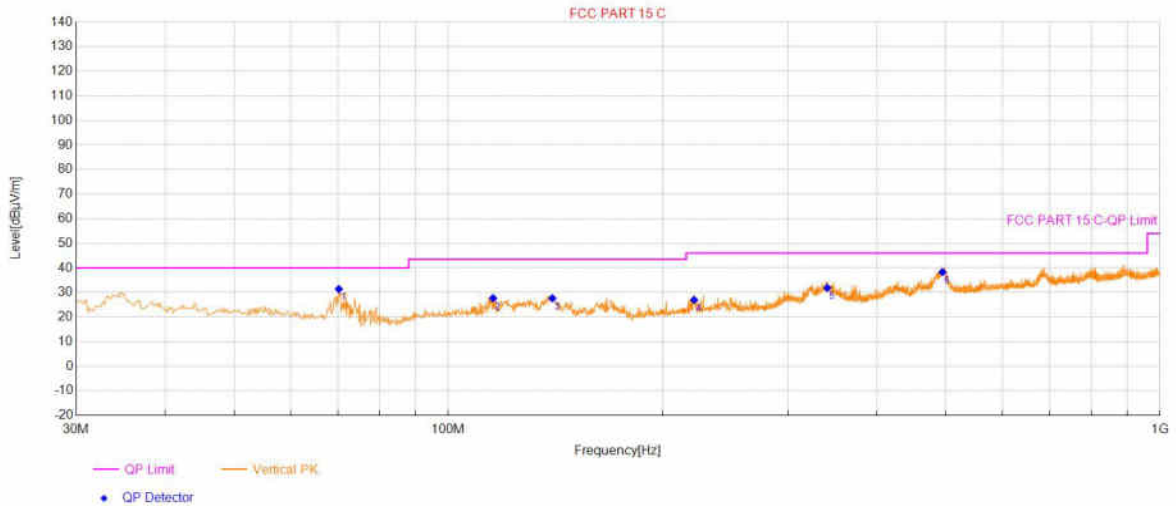

Final Data List

NO.	Frequency (MHz)	Factor (dB/m)	QP Value (dBµV/m)	QP Limit (dBµV/m)	QP Margin (dB)	Height (cm)	Angle (°)	Polarity	Verdict
1	70.1660	17.67	31.43	40.00	8.57	100	328	Vertical	PASS
2	115.5711	18.67	27.67	43.50	15.83	100	1	Vertical	PASS
3	140.0200	16.71	27.67	43.50	15.83	100	283	Vertical	PASS
4	221.5163	21.14	27.01	46.00	18.99	100	328	Vertical	PASS
5	340.8502	24.63	31.90	46.00	14.10	100	18	Vertical	PASS
6	494.7229	27.78	38.31	46.00	7.69	100	0	Vertical	PASS

Test Report

Project Information			
Customer:			
EUT:			
Model:	CH75GC	SN:	
Mode:	BLE1M_2480	Voltage:	AC120V/60Hz
Environment:	Temp: 25°C; Humi:60%	Engineer:	Fly Liao
Remark:	power set:default		
Test Standard: FCC PART 15 C			

Start of Test:2024-10-15 11:17:05

Test Graph

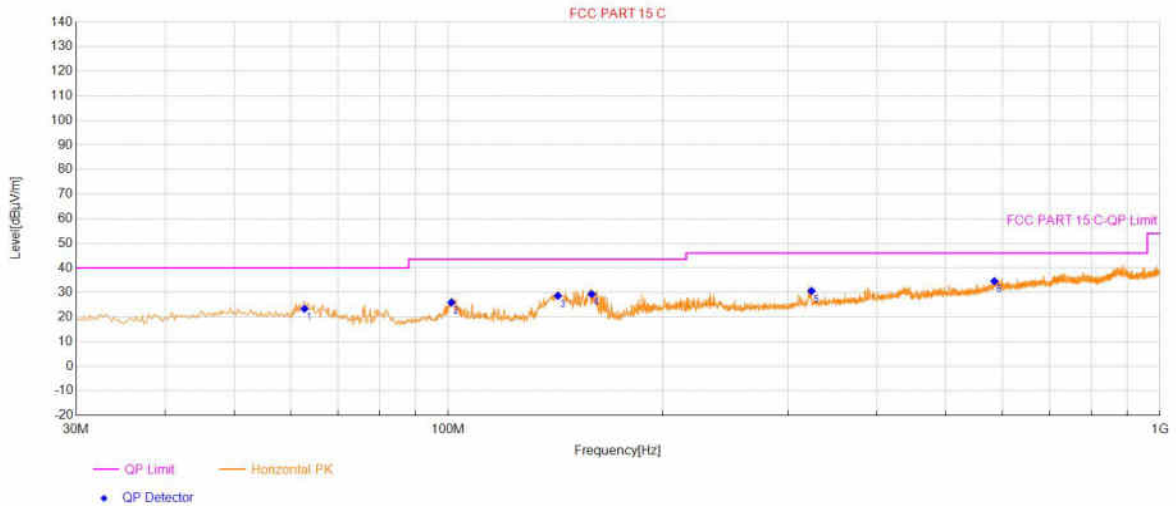

Final Data List

NO.	Frequency (MHz)	Factor (dB/m)	QP Value (dBµV/m)	QP Limit (dBµV/m)	QP Margin (dB)	Height (cm)	Angle (°)	Polarity	Verdict
1	62.7926	19.58	23.38	40.00	16.62	100	103	Horizontal	PASS
2	101.0182	19.91	25.91	43.50	17.59	100	360	Horizontal	PASS
3	142.5425	16.80	28.62	43.50	14.88	100	165	Horizontal	PASS
4	159.0358	17.50	29.35	43.50	14.15	100	50	Horizontal	PASS
5	323.7748	23.98	30.62	46.00	15.38	100	298	Horizontal	PASS
6	585.1450	29.92	34.57	46.00	11.43	100	360	Horizontal	PASS

Test Report

Project Information			
Customer:			
EUT:			
Model:	CH75GC	SN:	
Mode:	BLE1M_2480	Voltage:	AC120V/60Hz
Environment:	Temp: 25°C; Humi:60%	Engineer:	Fly Liao
Remark:	power set:default		
Test Standard: FCC PART 15 C			

Start of Test:2024-10-15 11:17:50

Test Graph

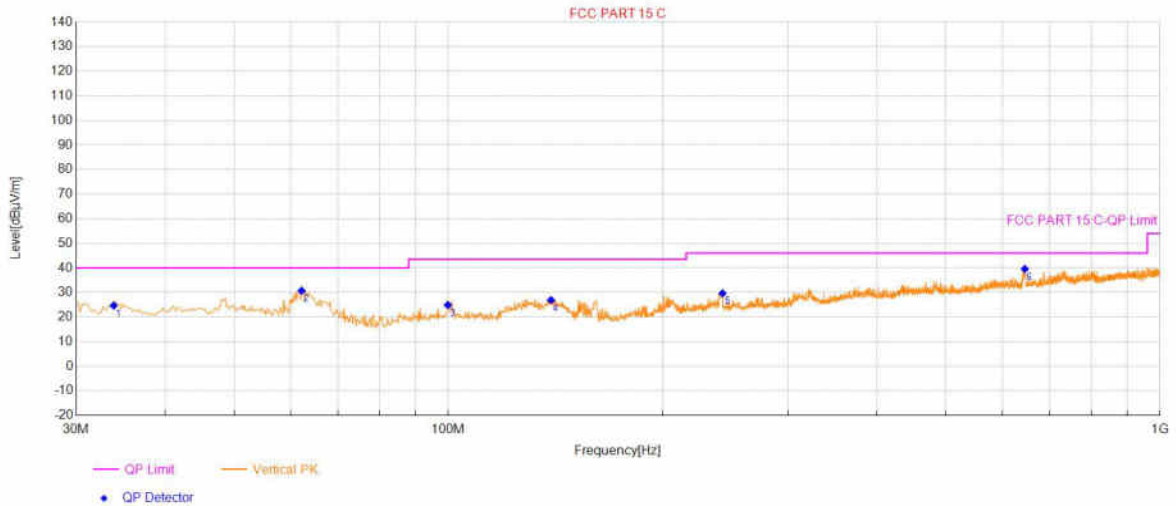

Final Data List

NO.	Frequency (MHz)	Factor (dB/m)	QP Value (dBµV/m)	QP Limit (dBµV/m)	QP Margin (dB)	Height (cm)	Angle (°)	Polarity	Verdict
1	33.8808	17.67	24.70	40.00	15.30	100	194	Vertical	PASS
2	62.2104	19.73	30.71	40.00	9.29	100	5	Vertical	PASS
3	99.8540	19.92	24.89	43.50	18.61	100	0	Vertical	PASS
4	139.4379	16.72	26.92	43.50	16.58	100	266	Vertical	PASS
5	242.8606	21.76	29.68	46.00	16.32	100	328	Vertical	PASS
6	645.6851	30.69	39.58	46.00	6.42	100	19	Vertical	PASS

APPENDIX B – Radiated Emission Above 1GHz Test Data Test Report

Project Information			
Customer:			
EUT:			
Model:	CH65GC	SN:	
Mode:	BLE1M_2402	Voltage:	AC120V/60Hz
Environment:	Temp: 25°C; Humi:60%	Engineer:	Fly Liao
Remark:	power set:default		
Test Standard: FCC PART 15 C			

Start of Test:2024-10-13 15:12:38

Test Graph

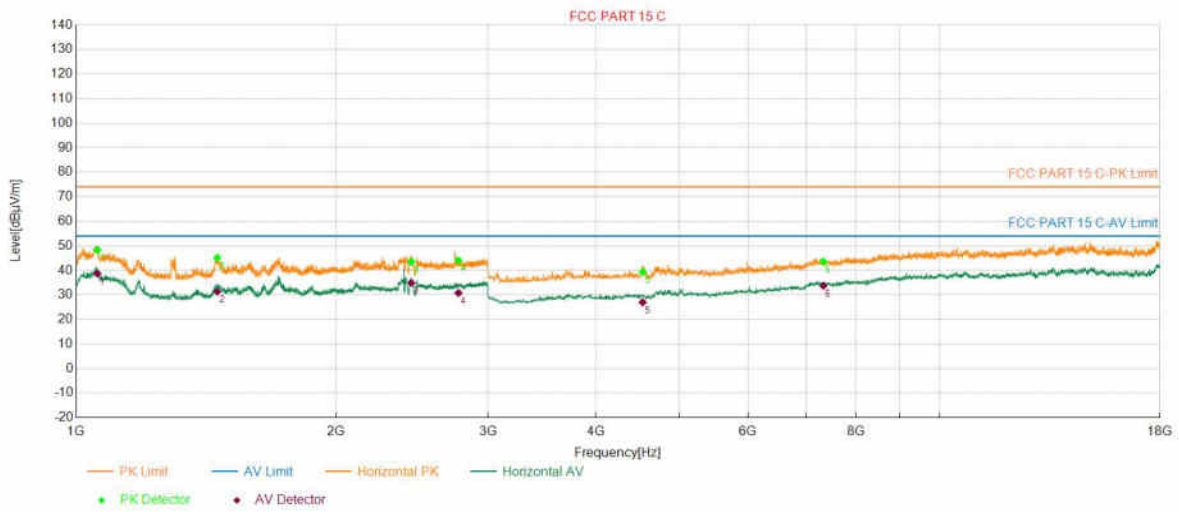

PK Final Data List											
NO.	Frequency (MHz)	Factor (dB/m)	PK Value (dBµV/m)	PK Limit (dBµV/m)	PK Margin (dB)	AV Value (dBµV/m)	AV Limit (dBµV/m)	AV Margin (dB)	Height (cm)	Angle (°)	Polarity
1	1058.4117	-1.16	48.34	74.00	25.66	38.67	54.00	15.33	150	151	Horizontal
2	1456.8914	-0.02	45.11	74.00	28.89	31.34	54.00	22.66	150	58	Horizontal
3	2444.2889	6.43	43.54	74.00	30.46	34.90	54.00	19.10	150	360	Horizontal
4	2771.9544	6.25	44.11	74.00	29.89	30.82	54.00	23.18	150	215	Horizontal
5	4530.3061	-6.27	39.37	74.00	34.63	27.02	54.00	26.98	150	114	Horizontal
6	7335.8672	3.21	43.54	74.00	30.46	33.72	54.00	20.28	150	343	Horizontal

Test Report

Project Information			
Customer:			
EUT:			
Model:	CH65GC	SN:	
Mode:	BLE1M_2402	Voltage:	AC120V/60Hz
Environment:	Temp: 25°C; Humi:60%	Engineer:	Fly Liao
Remark:	power set:default		
Test Standard: FCC PART 15 C			

Start of Test:2024-10-13 15:14:07

Test Graph

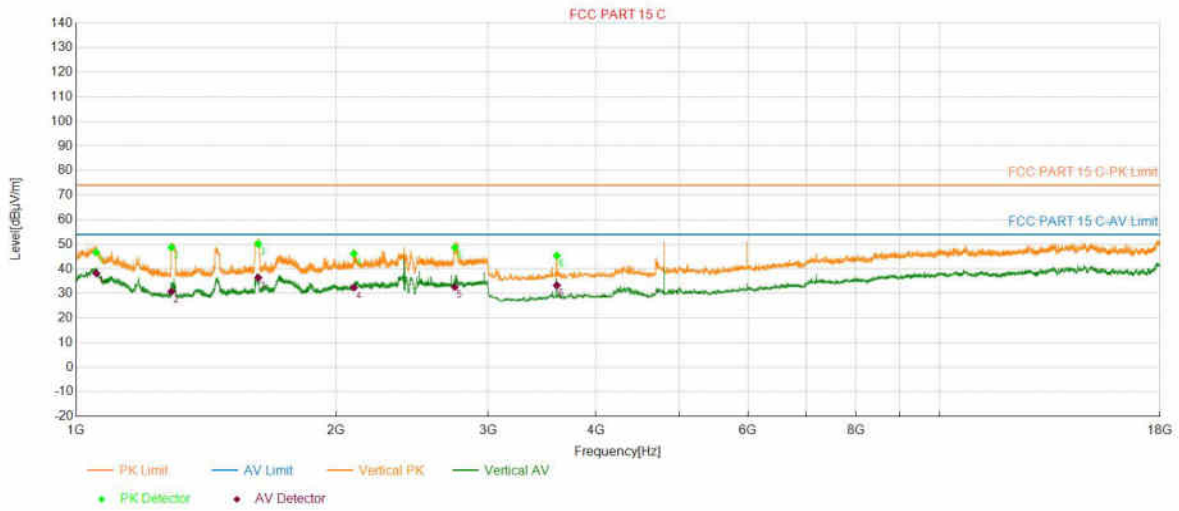

PK Final Data List											
NO.	Frequency (MHz)	Factor (dB/m)	PK Value (dBµV/m)	PK Limit (dBµV/m)	PK Margin (dB)	AV Value (dBµV/m)	AV Limit (dBµV/m)	AV Margin (dB)	Height (cm)	Angle (°)	Polarity
1	1055.2110	-1.16	46.64	74.00	27.36	38.21	54.00	15.79	150	193	Vertical
2	1289.6579	-0.42	48.73	74.00	25.27	30.85	54.00	23.15	150	352	Vertical
3	1625.3251	0.41	50.13	74.00	23.87	36.45	54.00	17.55	150	359	Vertical
4	2097.8196	2.93	46.18	74.00	27.82	32.42	54.00	21.58	150	8	Vertical
5	2745.1490	6.12	48.69	74.00	25.31	32.65	54.00	21.35	150	17	Vertical
6	3603.1206	-10.06	45.36	74.00	28.64	33.32	54.00	20.68	150	83	Vertical

Test Report

Project Information			
Customer:			
EUT:			
Model:	CH65GC	SN:	
Mode:	BLE1M_2440	Voltage:	AC120V/60Hz
Environment:	Temp: 25°C; Humi:60%	Engineer:	Fly Liao
Remark:	power set:default		
Test Standard: FCC PART 15 C			

Start of Test:2024-10-13 15:16:20

Test Graph

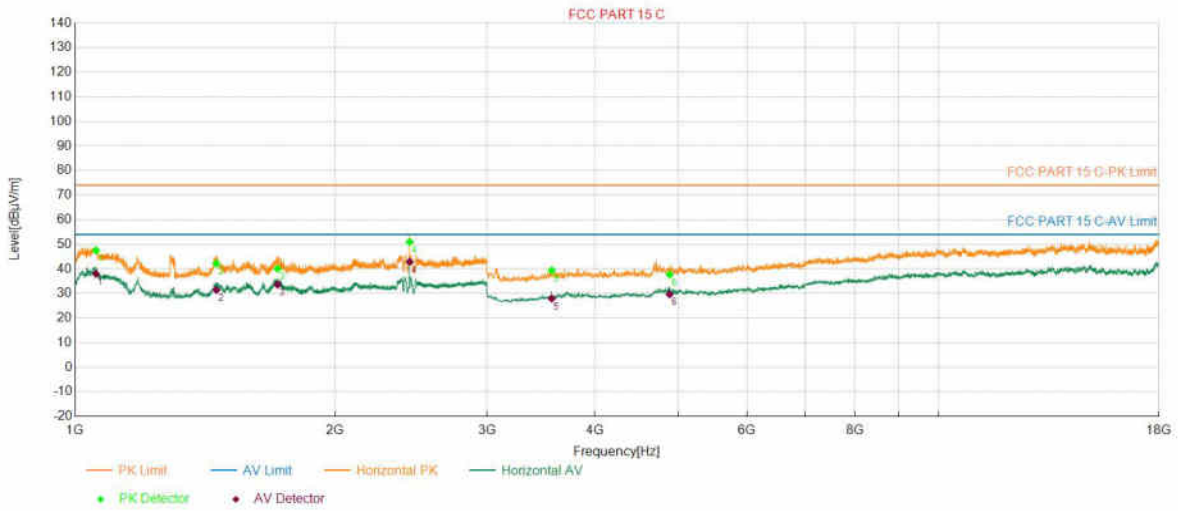

PK Final Data List											
NO.	Frequency (MHz)	Factor (dB/m)	PK Value (dBµV/m)	PK Limit (dBµV/m)	PK Margin (dB)	AV Value (dBµV/m)	AV Limit (dBµV/m)	AV Margin (dB)	Height (cm)	Angle (°)	Polarity
1	1057.2114	-1.16	47.51	74.00	26.49	37.96	54.00	16.04	150	151	Horizontal
2	1457.2915	-0.02	42.16	74.00	31.84	31.44	54.00	22.56	150	58	Horizontal
3	1715.7431	0.34	40.11	74.00	33.89	33.62	54.00	20.38	150	224	Horizontal
4	2440.2881	6.45	50.97	74.00	23.03	42.88	54.00	11.12	150	111	Horizontal
5	3564.1128	-10.02	39.36	74.00	34.64	27.97	54.00	26.03	150	228	Horizontal
6	4881.3763	-4.43	37.73	74.00	36.27	29.68	54.00	24.32	150	218	Horizontal

Test Report

Project Information			
Customer:			
EUT:			
Model:	CH65GC	SN:	
Mode:	BLE1M_2440	Voltage:	AC120V/60Hz
Environment:	Temp: 25°C; Humi:60%	Engineer:	Fly Liao
Remark:	power set:default		
Test Standard: FCC PART 15 C			

Start of Test:2024-10-13 15:17:49

Test Graph

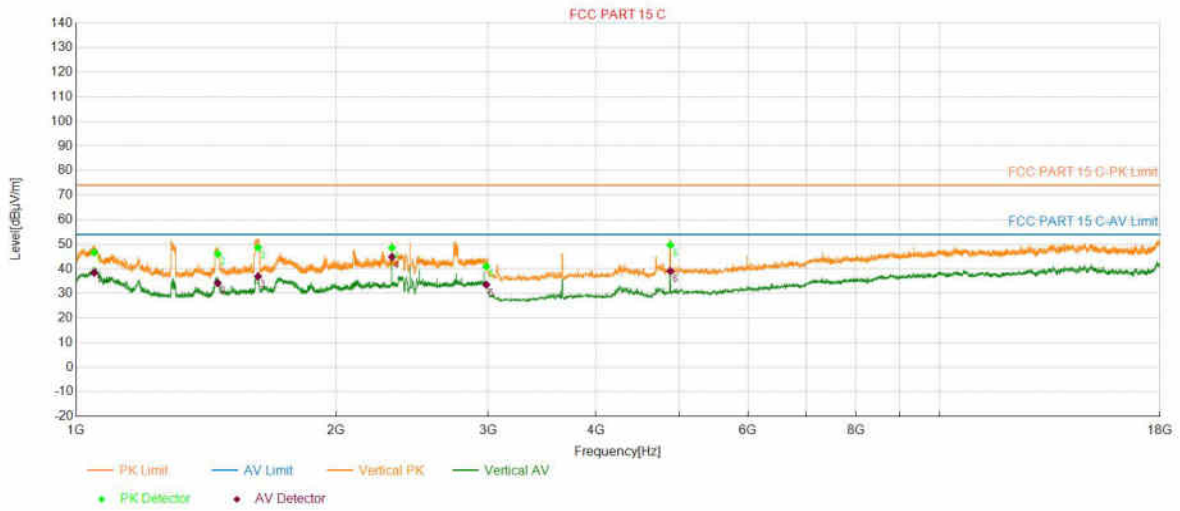

PK Final Data List											
NO.	Frequency (MHz)	Factor (dB/m)	PK Value (dBµV/m)	PK Limit (dBµV/m)	PK Margin (dB)	AV Value (dBµV/m)	AV Limit (dBµV/m)	AV Margin (dB)	Height (cm)	Angle (°)	Polarity
1	1049.6099	-1.17	46.64	74.00	27.36	38.46	54.00	15.54	150	193	Vertical
2	1458.8918	-0.02	46.05	74.00	27.95	34.23	54.00	19.77	150	193	Vertical
3	1624.5249	0.42	48.66	74.00	25.34	36.97	54.00	17.03	150	359	Vertical
4	2322.2645	3.96	48.58	74.00	25.42	44.90	54.00	9.10	150	277	Vertical
5	2985.1970	7.66	41.04	74.00	32.96	33.56	54.00	20.44	150	215	Vertical
6	4878.3757	-4.46	49.71	74.00	24.29	39.12	54.00	14.88	150	83	Vertical

Test Report

Project Information			
Customer:			
EUT:			
Model:	CH65GC	SN:	
Mode:	BLE1M_2480	Voltage:	AC120V/60Hz
Environment:	Temp: 25°C; Humi:60%	Engineer:	Fly Liao
Remark:	power set:default		
Test Standard: FCC PART 15 C			

Start of Test:2024-10-13 15:19:48

Test Graph

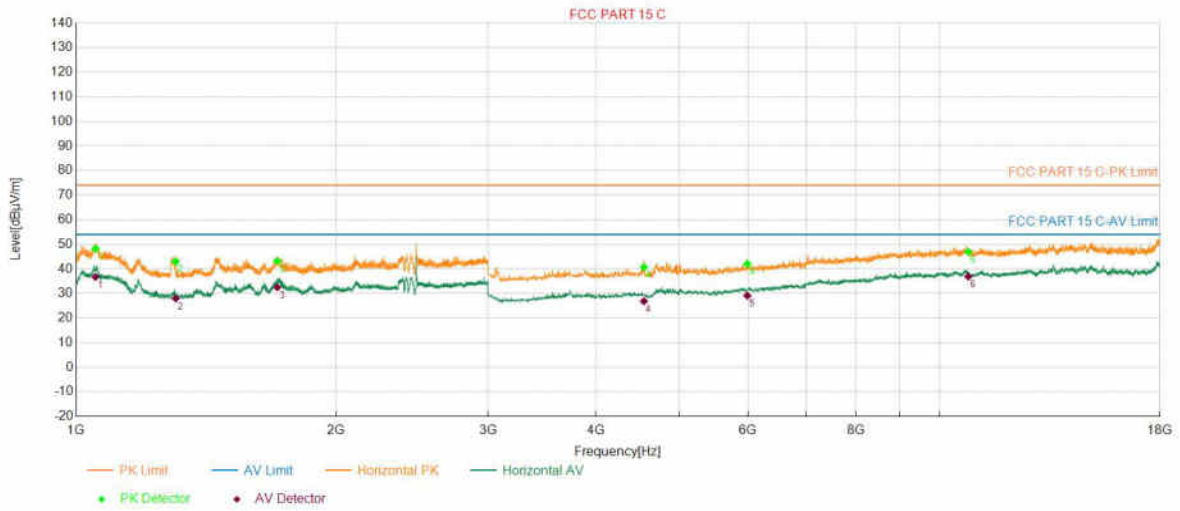

PK Final Data List											
NO.	Frequency (MHz)	Factor (dB/m)	PK Value (dBµV/m)	PK Limit (dBµV/m)	PK Margin (dB)	AV Value (dBµV/m)	AV Limit (dBµV/m)	AV Margin (dB)	Height (cm)	Angle (°)	Polarity
1	1052.8106	-1.17	48.24	74.00	25.76	36.73	54.00	17.27	150	152	Horizontal
2	1304.4609	-0.38	43.02	74.00	30.98	27.98	54.00	26.02	150	195	Horizontal
3	1709.7419	0.34	43.20	74.00	30.80	32.55	54.00	21.45	150	217	Horizontal
4	4545.3091	-6.30	40.73	74.00	33.27	26.88	54.00	27.12	150	114	Horizontal
5	5988.5977	-0.73	42.07	74.00	31.93	29.12	54.00	24.88	150	39	Horizontal
6	10795.5591	10.16	46.94	74.00	27.06	36.88	54.00	17.12	150	18	Horizontal

Test Report

Project Information			
Customer:			
EUT:			
Model:	CH65GC	SN:	
Mode:	BLE1M_2480	Voltage:	AC120V/60Hz
Environment:	Temp: 25°C; Humi:60%	Engineer:	Fly Liao
Remark:	power set:default		
Test Standard: FCC PART 15 C			

Start of Test:2024-10-13 15:21:18

Test Graph

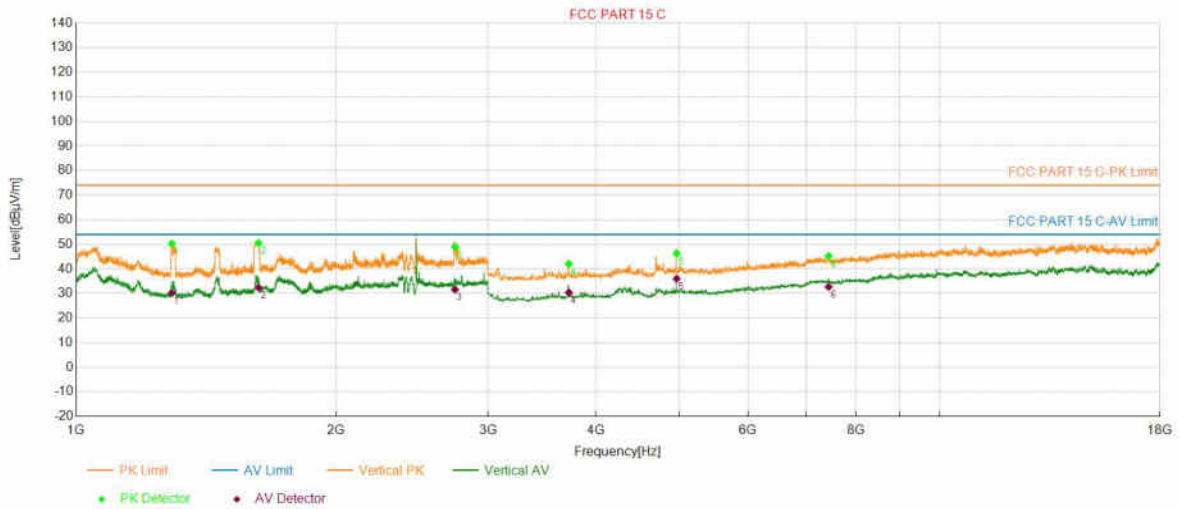

PK Final Data List											
NO.	Frequency (MHz)	Factor (dB/m)	PK Value (dBµV/m)	PK Limit (dBµV/m)	PK Margin (dB)	AV Value (dBµV/m)	AV Limit (dBµV/m)	AV Margin (dB)	Height (cm)	Angle (°)	Polarity
1	1290.8582	-0.41	50.27	74.00	23.73	30.22	54.00	23.78	150	351	Vertical
2	1626.5253	0.41	50.52	74.00	23.48	32.39	54.00	21.61	150	358	Vertical
3	2745.9492	6.12	48.95	74.00	25.05	31.63	54.00	22.37	150	17	Vertical
4	3720.1440	-9.13	42.03	74.00	31.97	30.42	54.00	23.58	150	104	Vertical
5	4959.3919	-4.16	46.29	74.00	27.71	36.02	54.00	17.98	150	72	Vertical
6	7437.8876	3.18	45.23	74.00	28.77	32.69	54.00	21.31	150	104	Vertical

Test Report

Project Information			
Customer:			
EUT:			
Model:	CH75GC	SN:	
Mode:	BLE1M_2402	Voltage:	AC120V/60Hz
Environment:	Temp: 25°C; Humi:60%	Engineer:	Fly Liao
Remark:	power set:default		
Test Standard: FCC PART 15 C			

Start of Test:2024-10-15 10:29:48

Test Graph

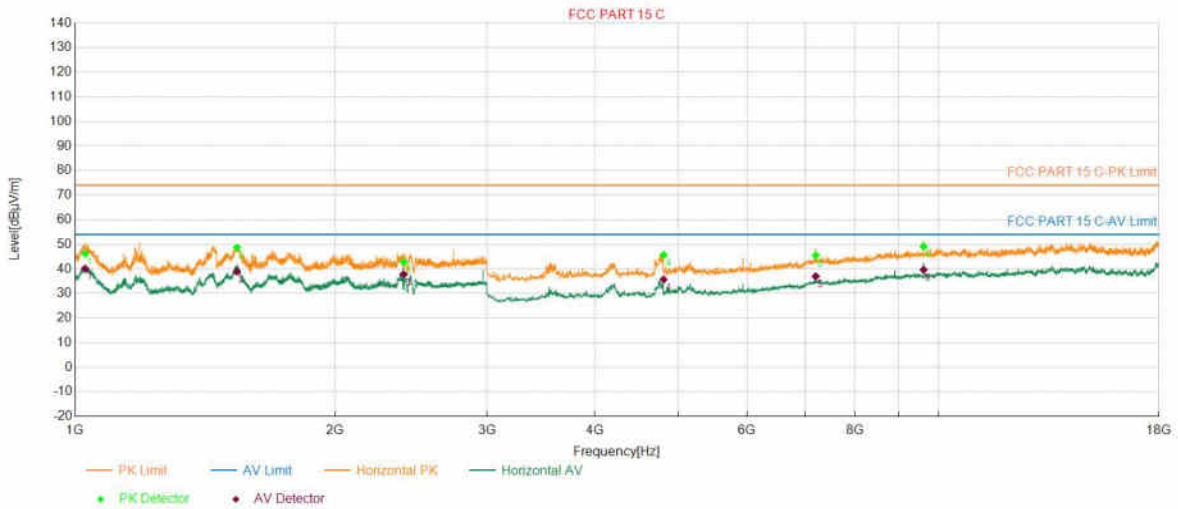

PK Final Data List											
NO.	Frequency (MHz)	Factor (dB/m)	PK Value (dBµV/m)	PK Limit (dBµV/m)	PK Margin (dB)	AV Value (dBµV/m)	AV Limit (dBµV/m)	AV Margin (dB)	Height (cm)	Angle (°)	Polarity
1	1027.2054	-1.22	46.17	74.00	27.83	40.07	54.00	13.93	150	121	Horizontal
2	1539.3079	0.21	48.67	74.00	25.33	38.94	54.00	15.06	150	81	Horizontal
3	2401.8804	6.74	42.78	74.00	31.22	37.77	54.00	16.23	150	205	Horizontal
4	4803.3607	-5.02	45.63	74.00	28.37	35.69	54.00	18.31	150	41	Horizontal
5	7206.8414	3.36	45.50	74.00	28.50	36.97	54.00	17.03	150	114	Horizontal
6	9607.3215	7.90	49.18	74.00	24.82	39.68	54.00	14.32	150	126	Horizontal

Test Report

Project Information			
Customer:			
EUT:			
Model:	CH75GC	SN:	
Mode:	BLE1M_2402	Voltage:	AC120V/60Hz
Environment:	Temp: 25°C; Humi:60%	Engineer:	Fly Liao
Remark:	power set:default		
Test Standard: FCC PART 15 C			

Start of Test:2024-10-15 10:31:18

Test Graph

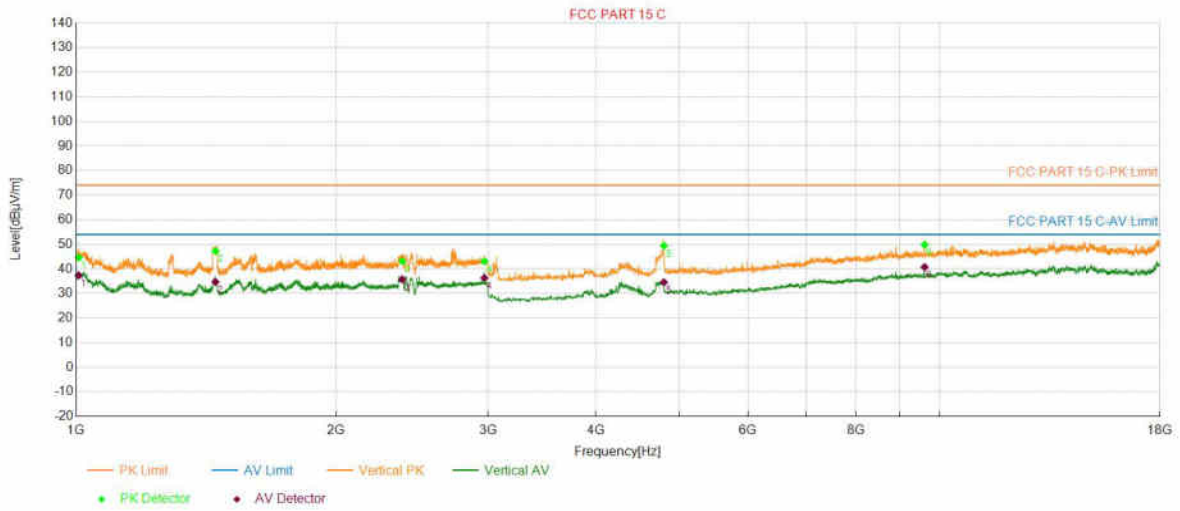

PK Final Data List											
NO.	Frequency (MHz)	Factor (dB/m)	PK Value (dBµV/m)	PK Limit (dBµV/m)	PK Margin (dB)	AV Value (dBµV/m)	AV Limit (dBµV/m)	AV Margin (dB)	Height (cm)	Angle (°)	Polarity
1	1006.8014	-1.27	44.62	74.00	29.38	37.38	54.00	16.62	150	2	Vertical
2	1450.0900	-0.03	47.25	74.00	26.75	34.72	54.00	19.28	150	360	Vertical
3	2385.8772	6.91	43.13	74.00	30.87	35.72	54.00	18.28	150	2	Vertical
4	2970.3941	7.57	43.08	74.00	30.92	36.31	54.00	17.69	150	2	Vertical
5	4794.3589	-5.08	49.42	74.00	24.58	34.57	54.00	19.43	150	93	Vertical
6	9607.3215	7.90	49.85	74.00	24.15	40.77	54.00	13.23	150	114	Vertical

Test Report

Project Information			
Customer:			
EUT:			
Model:	CH75GC	SN:	
Mode:	BLE1M_2440	Voltage:	AC120V/60Hz
Environment:	Temp: 25°C; Humi:60%	Engineer:	Fly Liao
Remark:	power set:default		
Test Standard: FCC PART 15 C			

Start of Test:2024-10-15 10:33:32

Test Graph

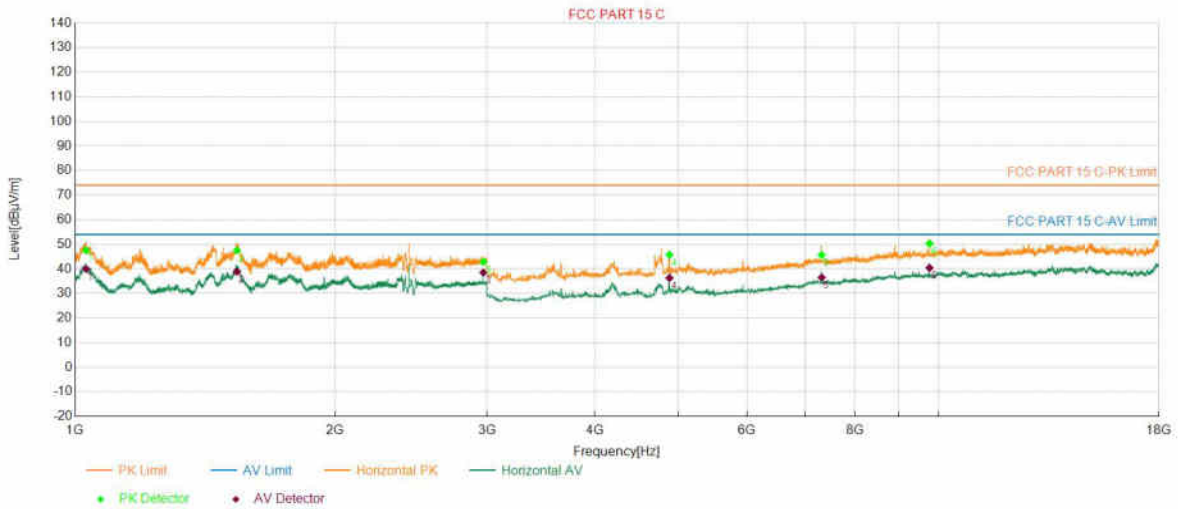

PK Final Data List											
NO.	Frequency (MHz)	Factor (dB/m)	PK Value (dBµV/m)	PK Limit (dBµV/m)	PK Margin (dB)	AV Value (dBµV/m)	AV Limit (dBµV/m)	AV Margin (dB)	Height (cm)	Angle (°)	Polarity
1	1029.6059	-1.22	47.55	74.00	26.45	39.99	54.00	14.01	150	120	Horizontal
2	1539.3079	0.21	47.53	74.00	26.47	38.90	54.00	15.10	150	87	Horizontal
3	2970.3941	7.57	42.88	74.00	31.12	38.55	54.00	15.45	150	87	Horizontal
4	4878.3757	-4.46	45.77	74.00	28.23	36.32	54.00	17.68	150	59	Horizontal
5	7320.8642	3.21	45.63	74.00	28.37	36.51	54.00	17.49	150	117	Horizontal
6	9760.3521	8.45	50.28	74.00	23.72	40.43	54.00	13.57	150	117	Horizontal

Test Report

Project Information			
Customer:			
EUT:			
Model:	CH75GC	SN:	
Mode:	BLE1M_2440	Voltage:	AC120V/60Hz
Environment:	Temp: 25°C; Humi:60%	Engineer:	Fly Liao
Remark:	power set:default		
Test Standard: FCC PART 15 C			

Start of Test:2024-10-15 10:35:05

Test Graph

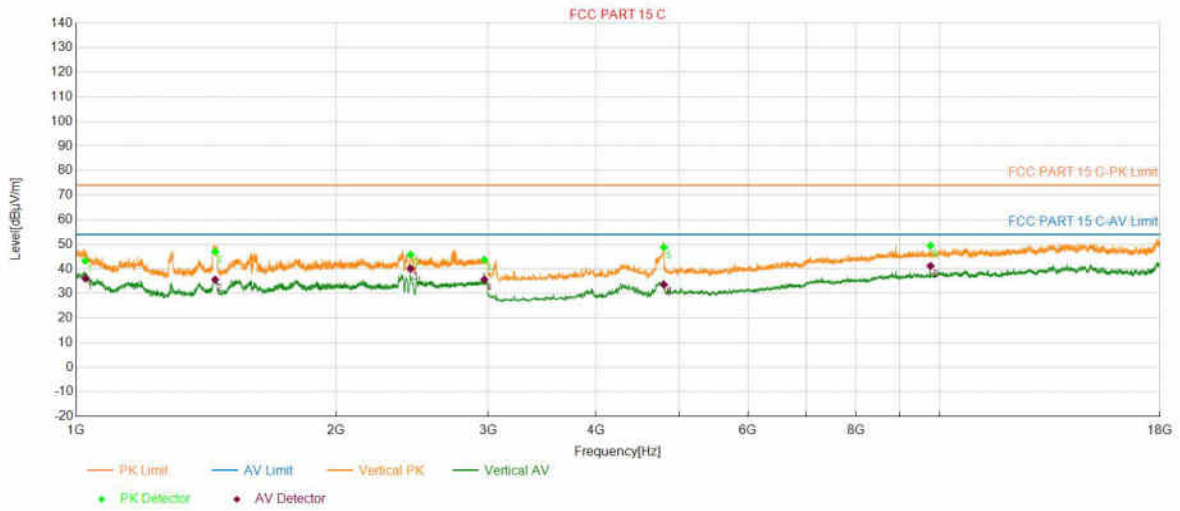

PK Final Data List											
NO.	Frequency (MHz)	Factor (dB/m)	PK Value (dBµV/m)	PK Limit (dBµV/m)	PK Margin (dB)	AV Value (dBµV/m)	AV Limit (dBµV/m)	AV Margin (dB)	Height (cm)	Angle (°)	Polarity
1	1024.8050	-1.23	43.27	74.00	30.73	36.15	54.00	17.85	150	348	Vertical
2	1448.8898	-0.04	46.96	74.00	27.04	35.64	54.00	18.36	150	359	Vertical
3	2439.8880	6.46	45.74	74.00	28.26	40.11	54.00	13.89	150	106	Vertical
4	2970.3941	7.57	43.70	74.00	30.30	35.74	54.00	18.26	150	2	Vertical
5	4794.3589	-5.08	48.77	74.00	25.23	33.60	54.00	20.40	150	95	Vertical
6	9760.3521	8.45	49.44	74.00	24.56	41.20	54.00	12.80	150	107	Vertical

Test Report

Project Information			
Customer:			
EUT:			
Model:	CH75GC	SN:	
Mode:	BLE1M_2480	Voltage:	AC120V/60Hz
Environment:	Temp: 25°C; Humi:60%	Engineer:	Fly Liao
Remark:	power set:default		
Test Standard: FCC PART 15 C			

Start of Test:2024-10-15 10:37:10

Test Graph

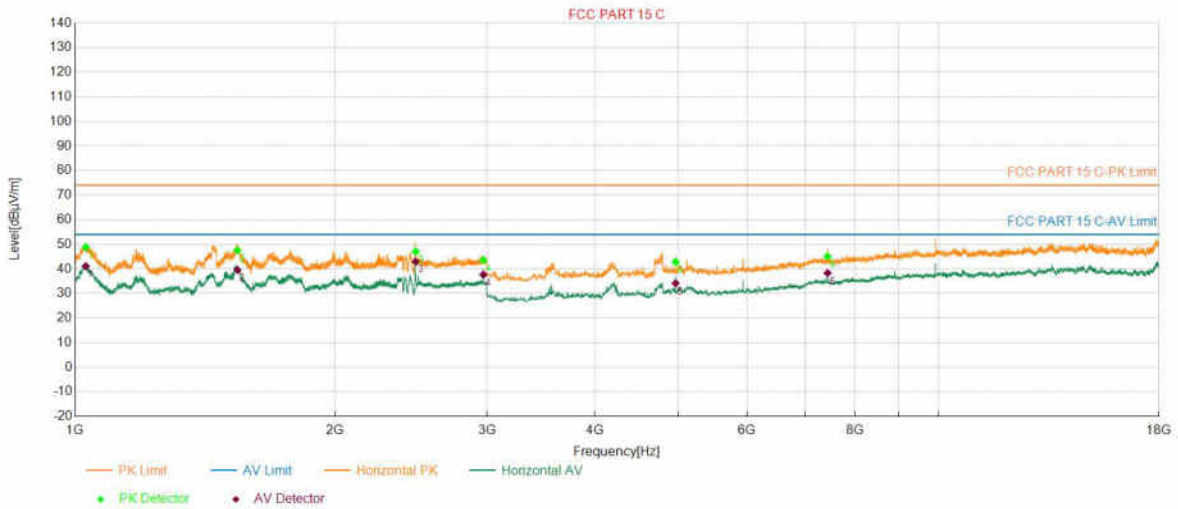

PK Final Data List											
NO.	Frequency (MHz)	Factor (dB/m)	PK Value (dBµV/m)	PK Limit (dBµV/m)	PK Margin (dB)	AV Value (dBµV/m)	AV Limit (dBµV/m)	AV Margin (dB)	Height (cm)	Angle (°)	Polarity
1	1028.8058	-1.22	48.80	74.00	25.20	41.12	54.00	12.88	150	115	Horizontal
2	1541.7083	0.22	47.57	74.00	26.43	39.56	54.00	14.44	150	84	Horizontal
3	2479.8960	6.17	47.06	74.00	26.94	43.00	54.00	11.00	150	248	Horizontal
4	2970.3941	7.57	43.59	74.00	30.41	37.66	54.00	16.34	150	84	Horizontal
5	4959.3919	-4.16	42.83	74.00	31.17	34.16	54.00	19.84	150	55	Horizontal
6	7437.8876	3.18	45.10	74.00	28.90	38.33	54.00	15.67	150	117	Horizontal

Test Report

Project Information			
Customer:			
EUT:			
Model:	CH75GC	SN:	
Mode:	BLE1M_2480	Voltage:	AC120V/60Hz
Environment:	Temp: 25°C; Humi:60%	Engineer:	Fly Liao
Remark:	power set:default		
Test Standard: FCC PART 15 C			

Start of Test:2024-10-15 10:38:40

Test Graph

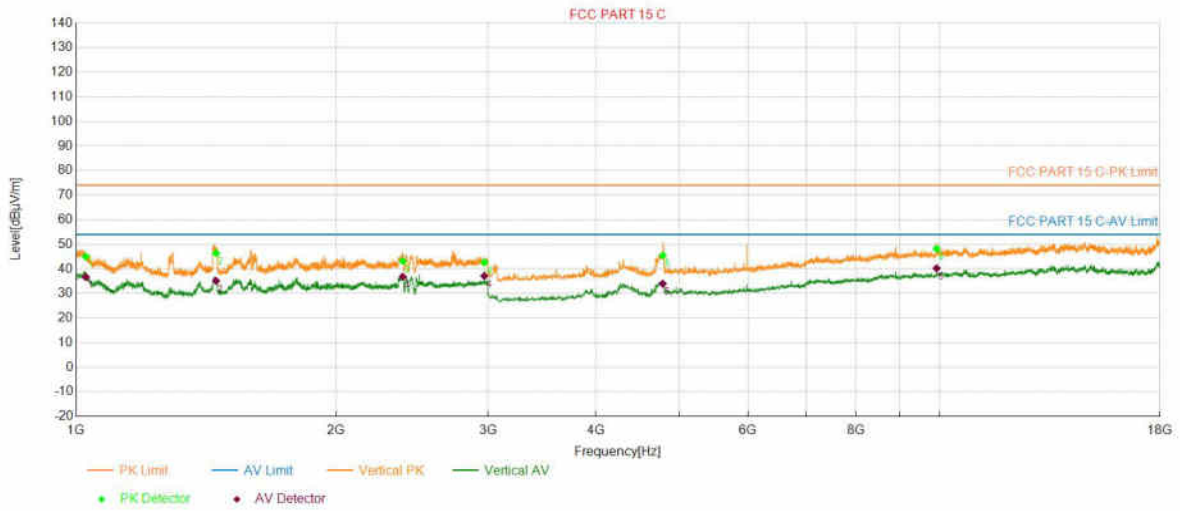

PK Final Data List											
NO.	Frequency (MHz)	Factor (dB/m)	PK Value (dBµV/m)	PK Limit (dBµV/m)	PK Margin (dB)	AV Value (dBµV/m)	AV Limit (dBµV/m)	AV Margin (dB)	Height (cm)	Angle (°)	Polarity
1	1026.0052	-1.23	45.03	74.00	28.97	36.68	54.00	17.32	150	348	Vertical
2	1452.0904	-0.03	46.40	74.00	27.60	35.13	54.00	18.87	150	358	Vertical
3	2389.4779	6.87	43.22	74.00	30.78	36.85	54.00	17.15	150	360	Vertical
4	2969.9940	7.56	42.63	74.00	31.37	37.13	54.00	16.87	150	2	Vertical
5	4779.3559	-5.16	45.42	74.00	28.58	33.98	54.00	20.02	150	102	Vertical
6	9919.3839	8.46	48.21	74.00	25.79	40.24	54.00	13.76	150	114	Vertical

Test Report

Project Information			
Customer:			
EUT:			
Model:	CH65GC	SN:	
Mode:	BLE1M_2402	Voltage:	AC120V/60Hz
Environment:	Temp: 25°C; Humi:60%	Engineer:	Fly Liao
Remark:	power set:default		
Test Standard: FCC Part15 C			

Start of Test:2024-10-13 15:45:22

Test Graph

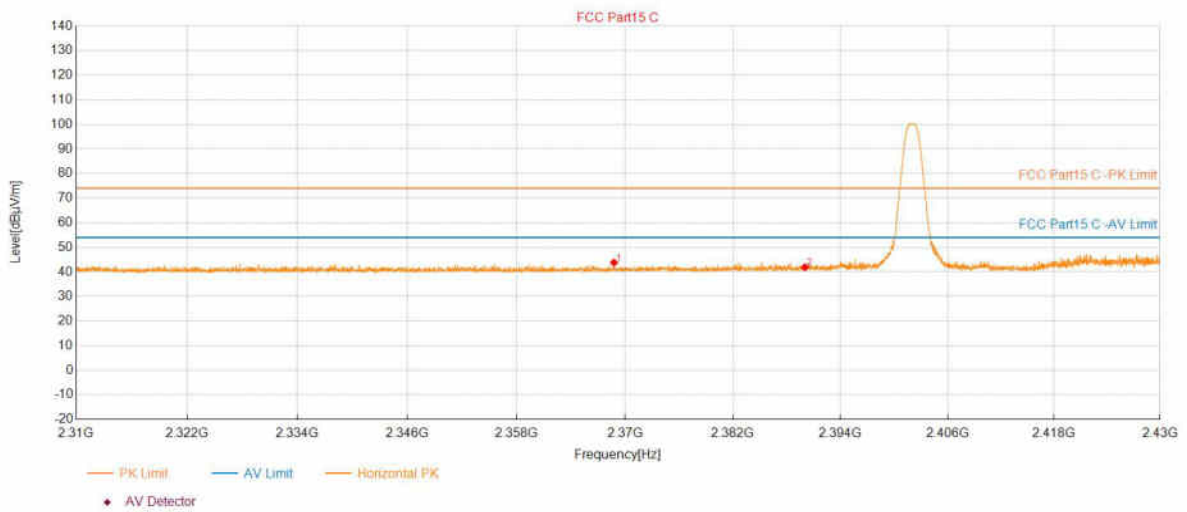

Suspected Data List							
NO.	Frequency (MHz)	Level (dBµV/m)	Limit (dBµV/m)	Margin (dB)	Height (cm)	Angle (°)	Polarity
1	2368.7878	43.78	74.00	30.22	150	107	Horizontal
2	2390.0080	41.90	74.00	32.10	150	152	Horizontal

Test Report

Project Information			
Customer:			
EUT:			
Model:	CH65GC	SN:	
Mode:	BLE1M_2402	Voltage:	AC120V/60Hz
Environment:	Temp: 25°C; Humi:60%	Engineer:	Fly Liao
Remark:	power set:default		
Test Standard: FCC Part15 C			

Start of Test:2024-10-13 15:46:20

Test Graph

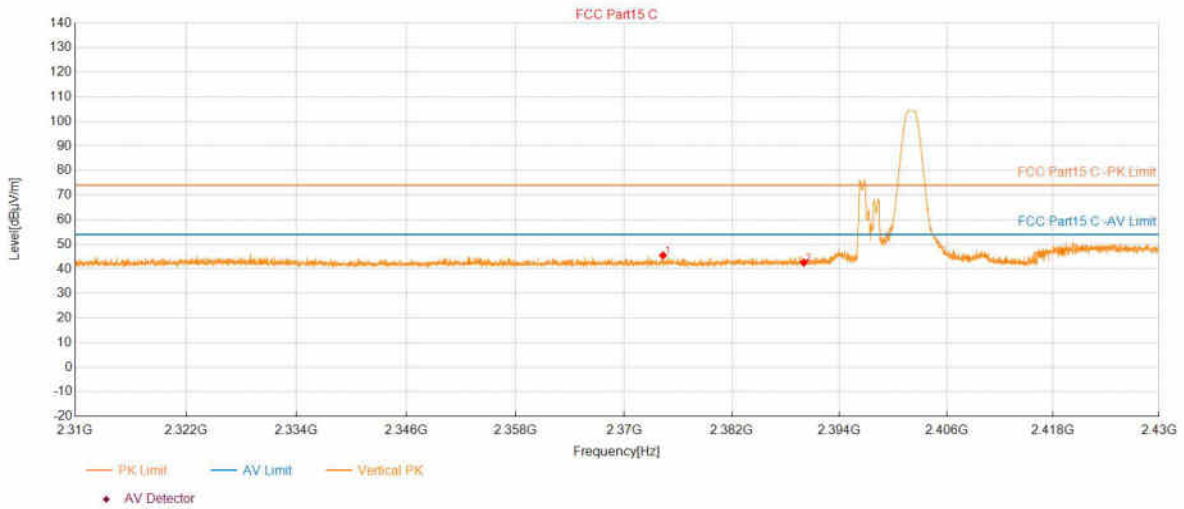

Suspected Data List							
NO.	Frequency (MHz)	Level (dBµV/m)	Limit (dBµV/m)	Margin (dB)	Height (cm)	Angle (°)	Polarity
1	2374.3329	45.51	74.00	28.49	150	5	Vertical
2	2390.0080	42.55	74.00	31.45	150	110	Vertical

Test Report

Project Information			
Customer:			
EUT:			
Model:	CH65GC	SN:	
Mode:	BLE1M_2480	Voltage:	AC120V/60Hz
Environment:	Temp: 25°C; Humi:60%	Engineer:	Fly Liao
Remark:	power set:default		
Test Standard: FCC Part15 C			

Start of Test:2024-10-13 15:48:39

Test Graph

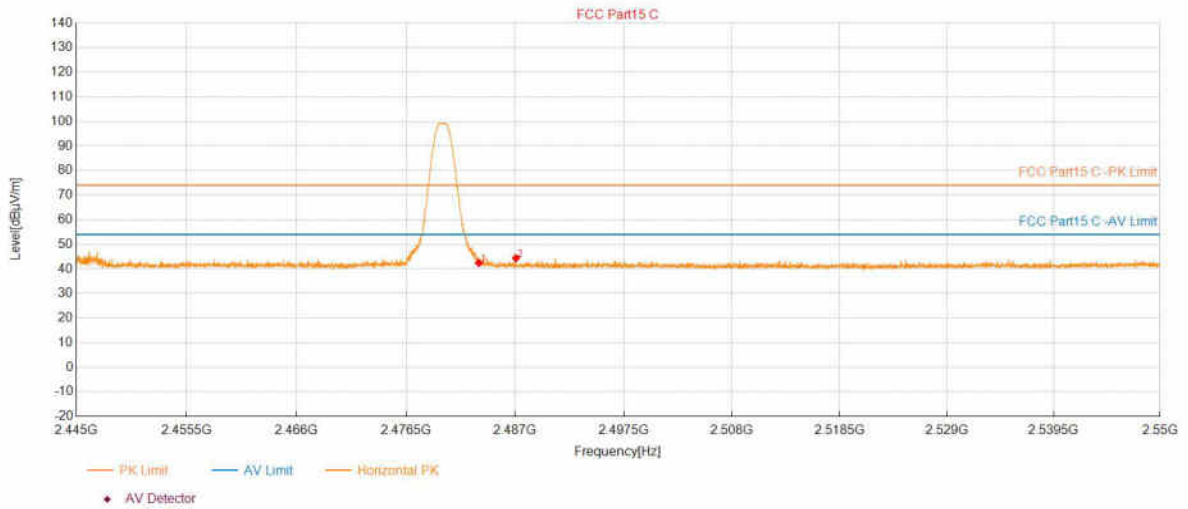

Suspected Data List							
NO.	Frequency (MHz)	Level (dBµV/m)	Limit (dBµV/m)	Margin (dB)	Height (cm)	Angle (°)	Polarity
1	2483.5007	42.44	74.00	31.56	150	132	Horizontal
2	2487.0714	44.37	74.00	29.63	150	125	Horizontal

Test Report

Project Information			
Customer:			
EUT:			
Model:	CH65GC	SN:	
Mode:	BLE1M_2480	Voltage:	AC120V/60Hz
Environment:	Temp: 25°C; Humi:60%	Engineer:	Fly Liao
Remark:	power set:default		
Test Standard: FCC Part15 C			

Start of Test:2024-10-13 15:49:26

Test Graph

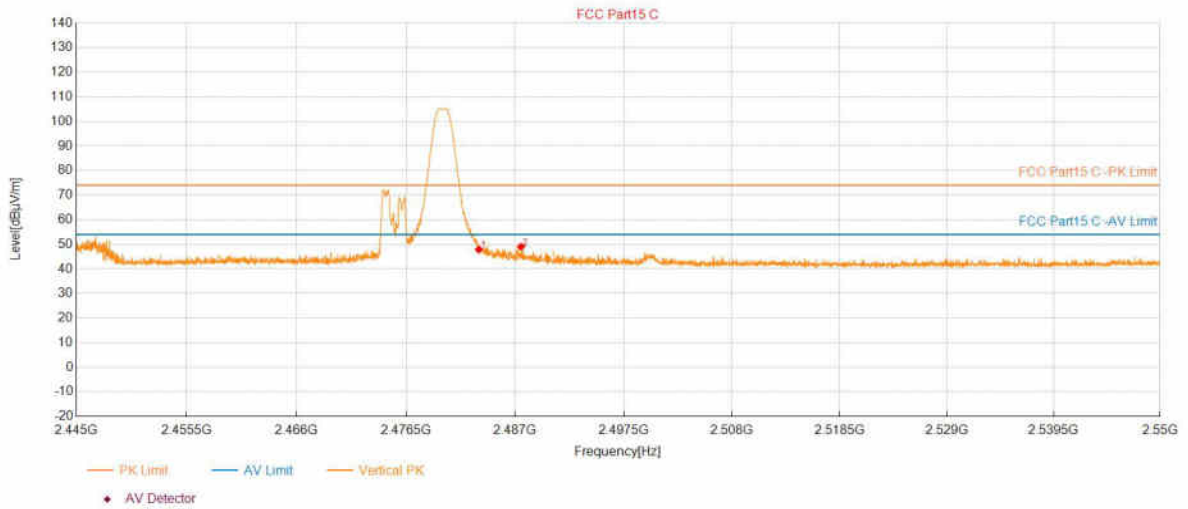

Suspected Data List							
NO.	Frequency (MHz)	Level (dBµV/m)	Limit (dBµV/m)	Margin (dB)	Height (cm)	Angle (°)	Polarity
1	2483.5007	47.89	74.00	26.11	150	114	Vertical
2	2487.5545	49.02	74.00	24.98	150	95	Vertical

Test Report

Project Information			
Customer:			
EUT:			
Model:	CH65GC	SN:	
Mode:	BLE2M_2402	Voltage:	AC120V/60Hz
Environment:	Temp: 25°C; Humi:60%	Engineer:	Fly Liao
Remark:	power set:default		
Test Standard: FCC Part15 C			

Start of Test:2024-10-13 15:51:33

Test Graph

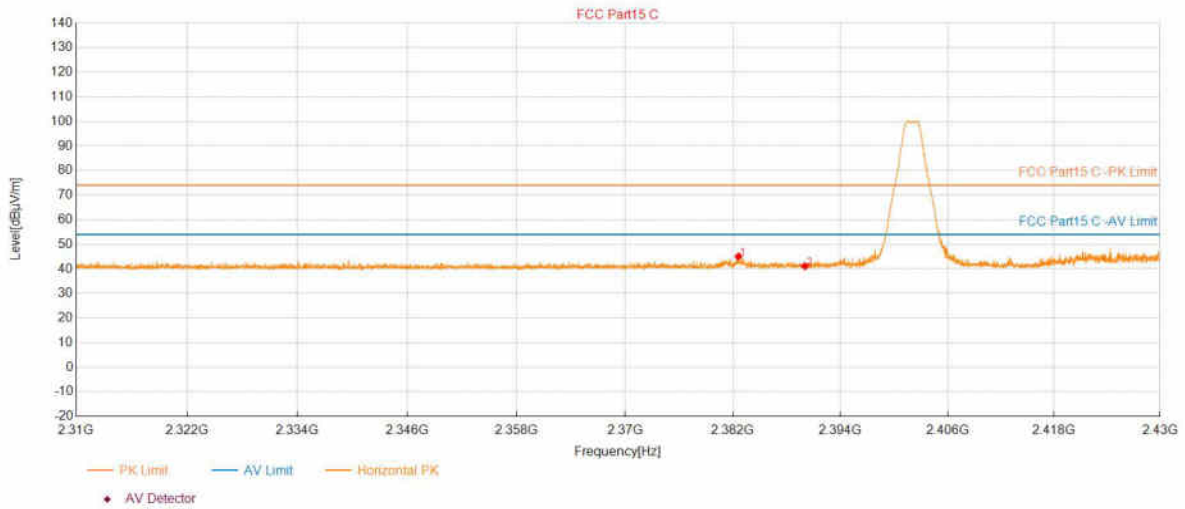

Suspected Data List							
NO.	Frequency (MHz)	Level (dBµV/m)	Limit (dBµV/m)	Margin (dB)	Height (cm)	Angle (°)	Polarity
1	2382.6145	45.09	74.00	28.91	150	107	Horizontal
2	2390.0080	41.12	74.00	32.88	150	206	Horizontal

Test Report

Project Information			
Customer:			
EUT:			
Model:	CH65GC	SN:	
Mode:	BLE2M_2402	Voltage:	AC120V/60Hz
Environment:	Temp: 25°C; Humi:60%	Engineer:	Fly Liao
Remark:	power set:default		
Test Standard: FCC Part15 C			

Start of Test:2024-10-13 15:52:23

Test Graph

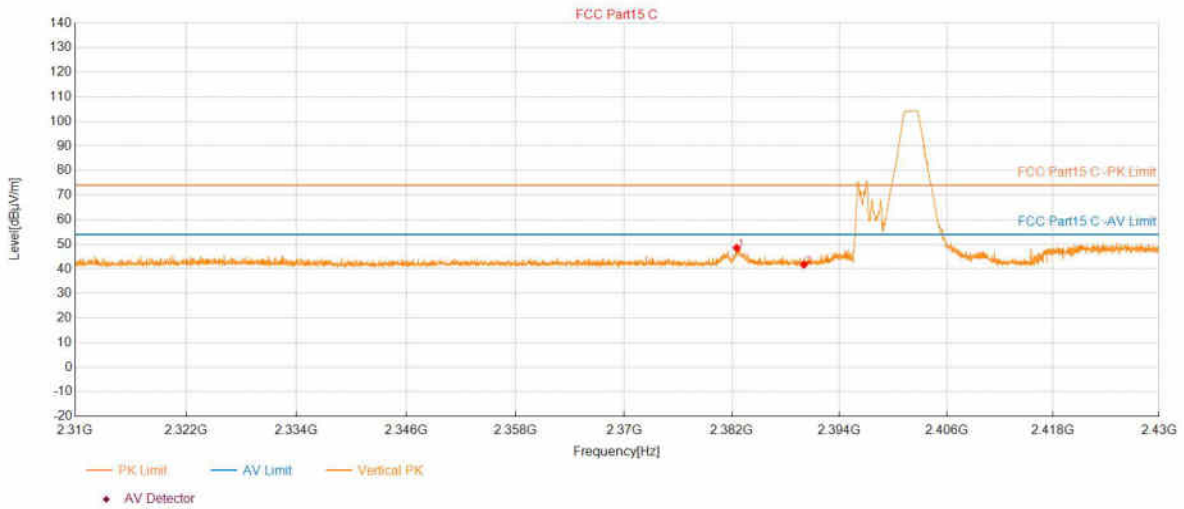

Suspected Data List							
NO.	Frequency (MHz)	Level (dBµV/m)	Limit (dBµV/m)	Margin (dB)	Height (cm)	Angle (°)	Polarity
1	2382.5185	48.53	74.00	25.47	150	109	Vertical
2	2390.0080	41.73	74.00	32.27	150	357	Vertical

Test Report

Project Information			
Customer:			
EUT:			
Model:	CH65GC	SN:	
Mode:	BLE2M_2480	Voltage:	AC120V/60Hz
Environment:	Temp: 25°C; Humi:60%	Engineer:	Fly Liao
Remark:	power set:default		
Test Standard: FCC Part15 C			

Start of Test:2024-10-13 15:54:02

Test Graph

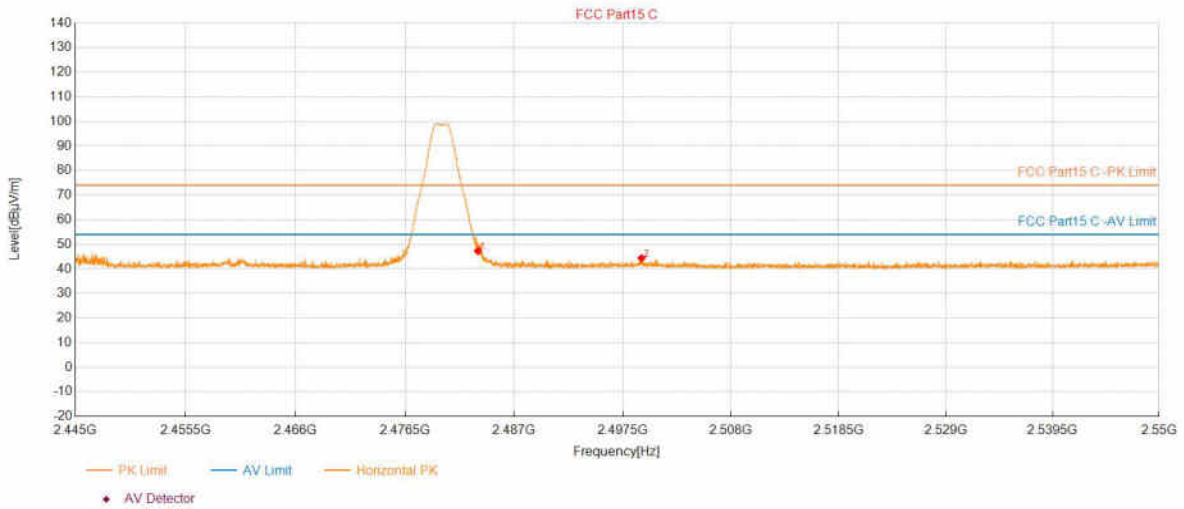

Suspected Data List							
NO.	Frequency (MHz)	Level (dBµV/m)	Limit (dBµV/m)	Margin (dB)	Height (cm)	Angle (°)	Polarity
1	2483.5007	47.28	74.00	26.72	150	120	Horizontal
2	2499.3169	44.39	74.00	29.61	150	111	Horizontal

Test Report

Project Information			
Customer:			
EUT:			
Model:	CH65GC	SN:	
Mode:	BLE2M_2480	Voltage:	AC120V/60Hz
Environment:	Temp: 25°C; Humi:60%	Engineer:	Fly Liao
Remark:	power set:default		
Test Standard: FCC Part15 C			

Start of Test:2024-10-13 15:54:49

Test Graph

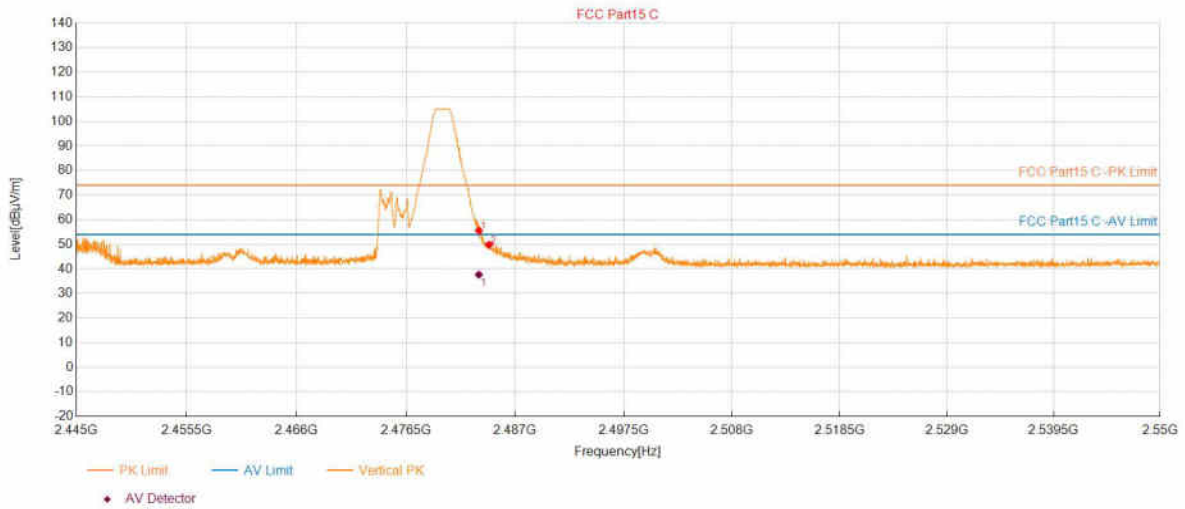

Suspected Data List							
NO.	Frequency (MHz)	Level (dBµV/m)	Limit (dBµV/m)	Margin (dB)	Height (cm)	Angle (°)	Polarity
1	2483.5007	55.59	74.00	18.41	150	86	Vertical
2	2484.4879	49.82	74.00	24.18	150	95	Vertical

PK Final Data List								
NO.	Frequency (MHz)	Factor (dB/m)	AV Value (dBµV/m)	AV Limit (dBµV/m)	AV Margin (dB)	Height (cm)	Angle (°)	Polarity
1	2483.5007	3.98	37.66	54.00	16.34	150	86	Vertical

Test Report

Project Information			
Customer:			
EUT:			
Model:	CH75GC	SN:	
Mode:	BLE1M_2402	Voltage:	AC120V/60Hz
Environment:	Temp: 25°C; Humi:60%	Engineer:	Fly Liao
Remark:	power set:default		
Test Standard: FCC Part15 C			

Start of Test:2024-10-15 11:00:40

Test Graph

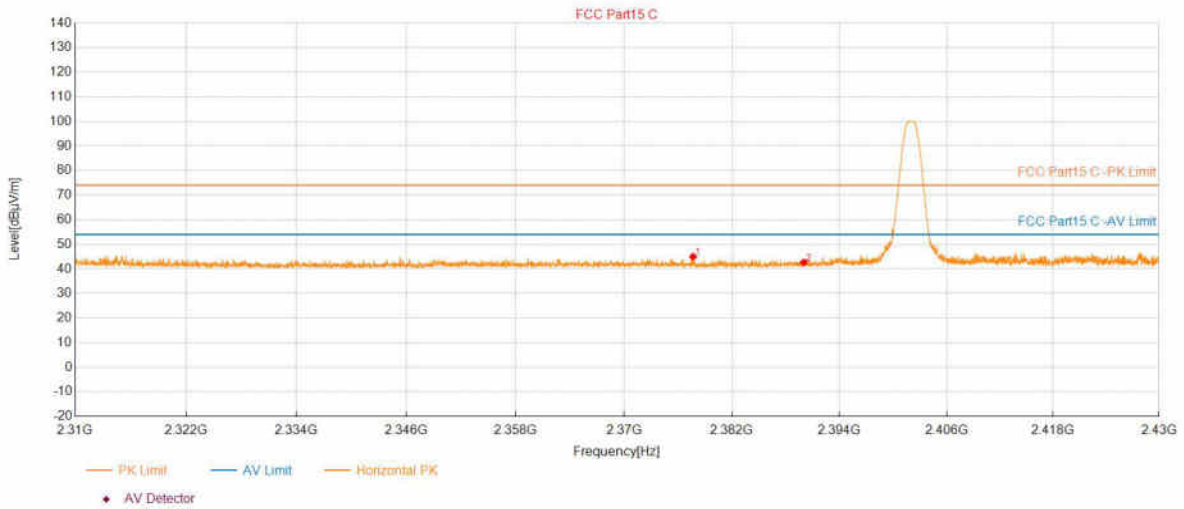

Suspected Data List							
NO.	Frequency (MHz)	Level (dBµV/m)	Limit (dBµV/m)	Margin (dB)	Height (cm)	Angle (°)	Polarity
1	2377.6695	44.95	74.00	29.05	150	98	Horizontal
2	2390.0080	42.57	74.00	31.43	150	214	Horizontal

Test Report

Project Information			
Customer:			
EUT:			
Model:	CH75GC	SN:	
Mode:	BLE1M_2402	Voltage:	AC120V/60Hz
Environment:	Temp: 25°C; Humi:60%	Engineer:	Fly Liao
Remark:	power set:default		
Test Standard: FCC Part15 C			

Start of Test:2024-10-15 11:01:30

Test Graph

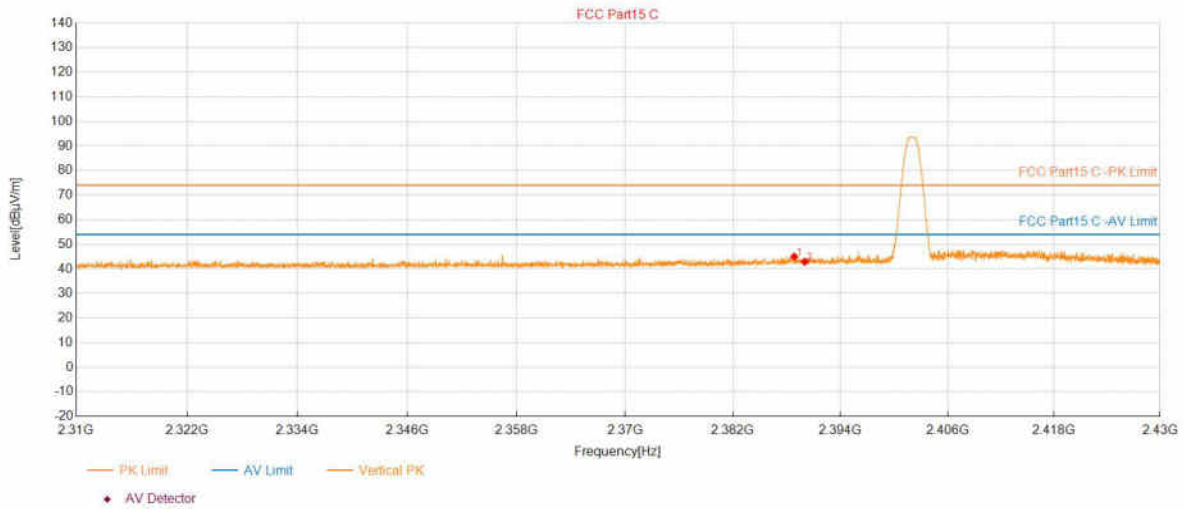

Suspected Data List							
NO.	Frequency (MHz)	Level (dBµV/m)	Limit (dBµV/m)	Margin (dB)	Height (cm)	Angle (°)	Polarity
1	2388.8318	45.01	74.00	28.99	150	0	Vertical
2	2390.0080	42.89	74.00	31.11	150	0	Vertical

Test Report

Project Information			
Customer:			
EUT:			
Model:	CH75GC	SN:	
Mode:	BLE1M_2480	Voltage:	AC120V/60Hz
Environment:	Temp: 25°C; Humi:60%	Engineer:	Fly Liao
Remark:	power set:default		
Test Standard: FCC Part15 C			

Start of Test:2024-10-15 11:03:12

Test Graph

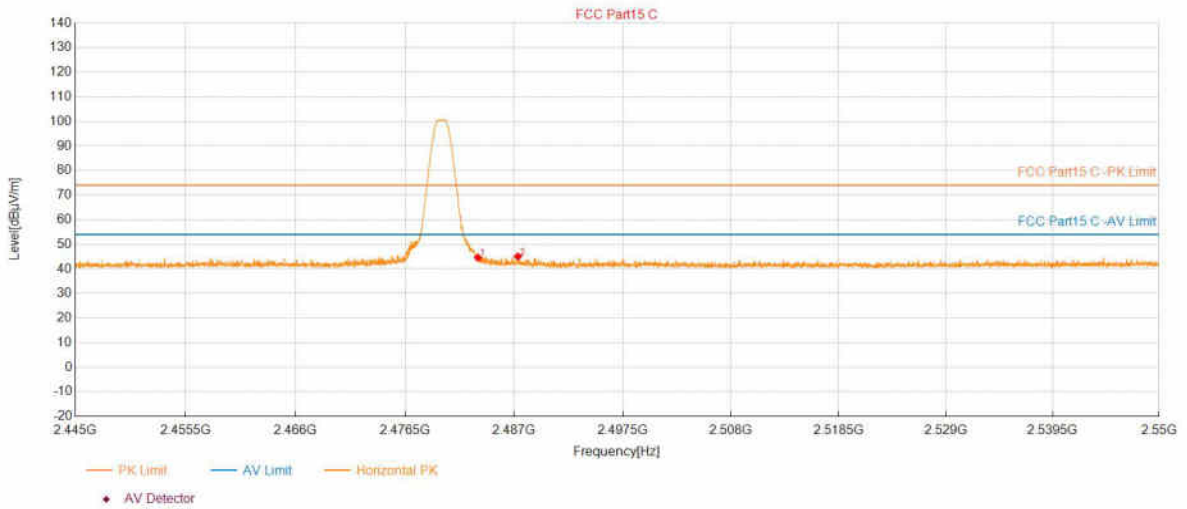

Suspected Data List							
NO.	Frequency (MHz)	Level (dBµV/m)	Limit (dBµV/m)	Margin (dB)	Height (cm)	Angle (°)	Polarity
1	2483.5007	44.61	74.00	29.39	150	62	Horizontal
2	2487.3445	45.01	74.00	28.99	150	238	Horizontal

Test Report

Project Information			
Customer:			
EUT:			
Model:	CH75GC	SN:	
Mode:	BLE1M_2480	Voltage:	AC120V/60Hz
Environment:	Temp: 25°C; Humi:60%	Engineer:	Fly Liao
Remark:	power set:default		
Test Standard: FCC Part15 C			

Start of Test:2024-10-15 11:03:59

Test Graph

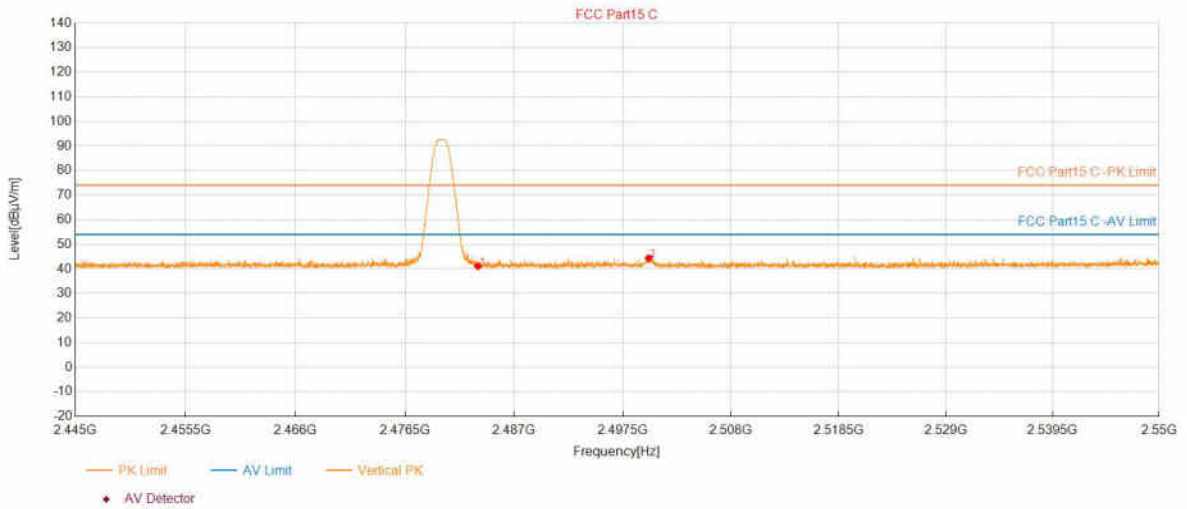

Suspected Data List							
NO.	Frequency (MHz)	Level (dBµV/m)	Limit (dBµV/m)	Margin (dB)	Height (cm)	Angle (°)	Polarity
1	2483.5007	41.12	74.00	32.88	150	222	Vertical
2	2500.0100	44.35	74.00	29.65	150	27	Vertical

Test Report

Project Information			
Customer:			
EUT:			
Model:	CH75GC	SN:	
Mode:	BLE2M_2402	Voltage:	AC120V/60Hz
Environment:	Temp: 25°C; Humi:60%	Engineer:	Fly Liao
Remark:	power set:default		
Test Standard: FCC Part15 C			

Start of Test:2024-10-15 11:05:49

Test Graph

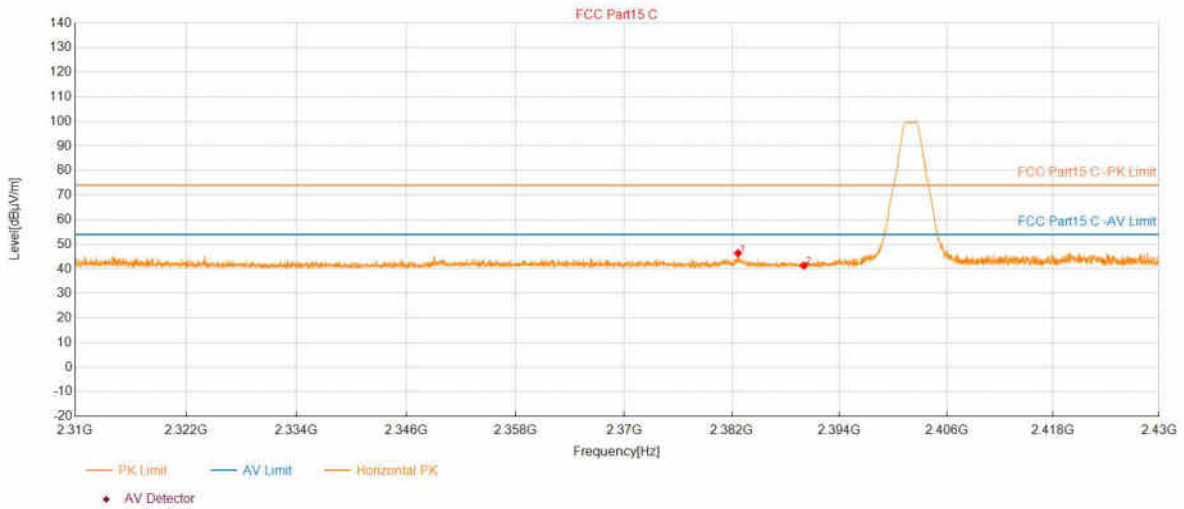

Suspected Data List							
NO.	Frequency (MHz)	Level (dBµV/m)	Limit (dBµV/m)	Margin (dB)	Height (cm)	Angle (°)	Polarity
1	2382.6625	46.41	74.00	27.59	150	212	Horizontal
2	2390.0080	41.33	74.00	32.67	150	359	Horizontal

Test Report

Project Information			
Customer:			
EUT:			
Model:	CH75GC	SN:	
Mode:	BLE2M_2402	Voltage:	AC120V/60Hz
Environment:	Temp: 25°C; Humi:60%	Engineer:	Fly Liao
Remark:	power set:default		
Test Standard: FCC Part15 C			

Start of Test:2024-10-15 11:06:40

Test Graph

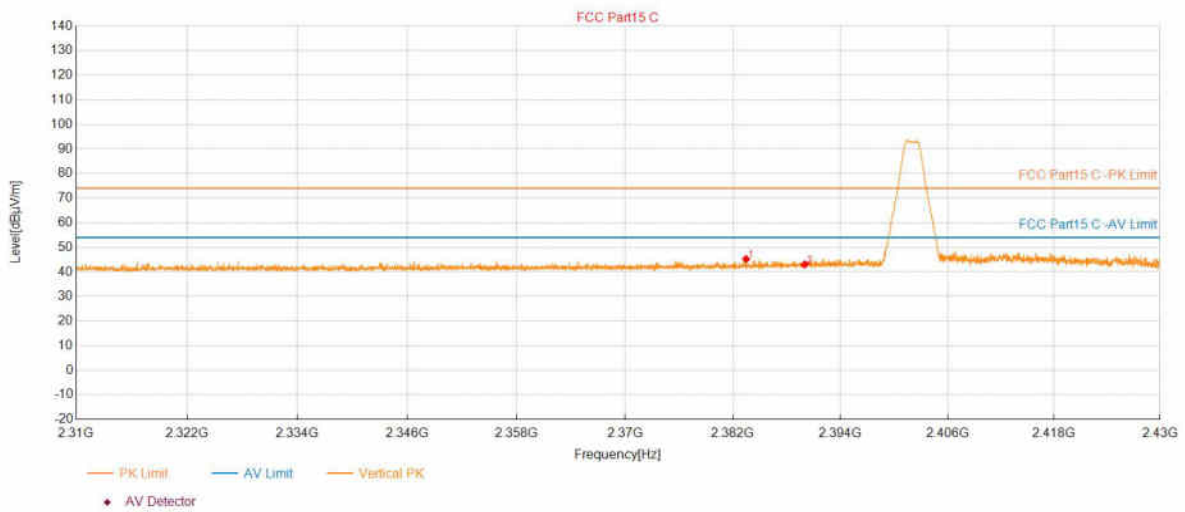

Suspected Data List							
NO.	Frequency (MHz)	Level (dBµV/m)	Limit (dBµV/m)	Margin (dB)	Height (cm)	Angle (°)	Polarity
1	2383.4547	45.26	74.00	28.74	150	1	Vertical
2	2390.0080	43.03	74.00	30.97	150	0	Vertical

Test Report

Project Information			
Customer:			
EUT:			
Model:	CH75GC	SN:	
Mode:	BLE2M_2480	Voltage:	AC120V/60Hz
Environment:	Temp: 25°C; Humi:60%	Engineer:	Fly Liao
Remark:	power set:default		
Test Standard: FCC Part15 C			

Start of Test:2024-10-15 11:08:08

Test Graph

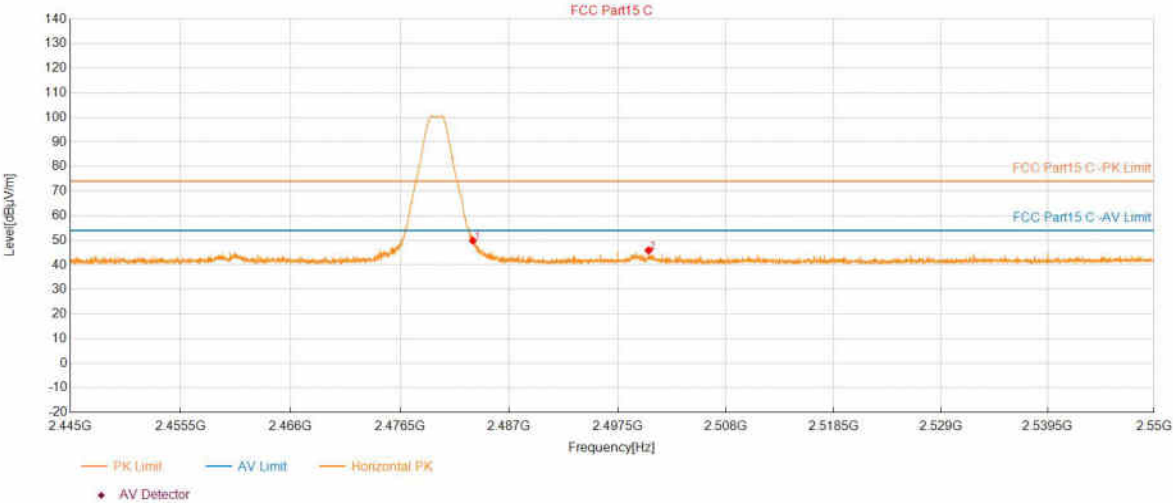

Suspected Data List							
NO.	Frequency (MHz)	Level (dBµV/m)	Limit (dBµV/m)	Margin (dB)	Height (cm)	Angle (°)	Polarity
1	2483.5007	49.82	74.00	24.18	150	238	Horizontal
2	2500.4931	45.92	74.00	28.08	150	53	Horizontal

Test Report

Project Information			
Customer:			
EUT:			
Model:	CH75GC	SN:	
Mode:	BLE2M_2480	Voltage:	AC120V/60Hz
Environment:	Temp: 25°C; Humi:60%	Engineer:	Fly Liao
Remark:	power set:default		
Test Standard: FCC Part15 C			

Start of Test:2024-10-15 11:08:55

Test Graph

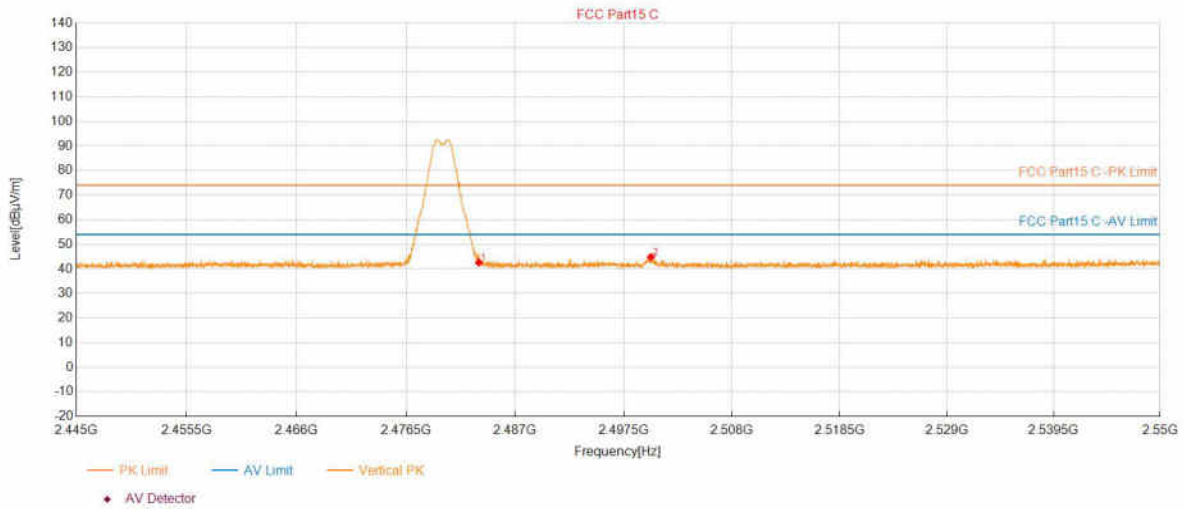

Suspected Data List							
NO.	Frequency (MHz)	Level (dBµV/m)	Limit (dBµV/m)	Margin (dB)	Height (cm)	Angle (°)	Polarity
1	2483.5007	42.55	74.00	31.45	150	220	Vertical
2	2500.1360	44.82	74.00	29.18	150	309	Vertical

APPENDIX C – AC Power Line Conducted Emission Test Data

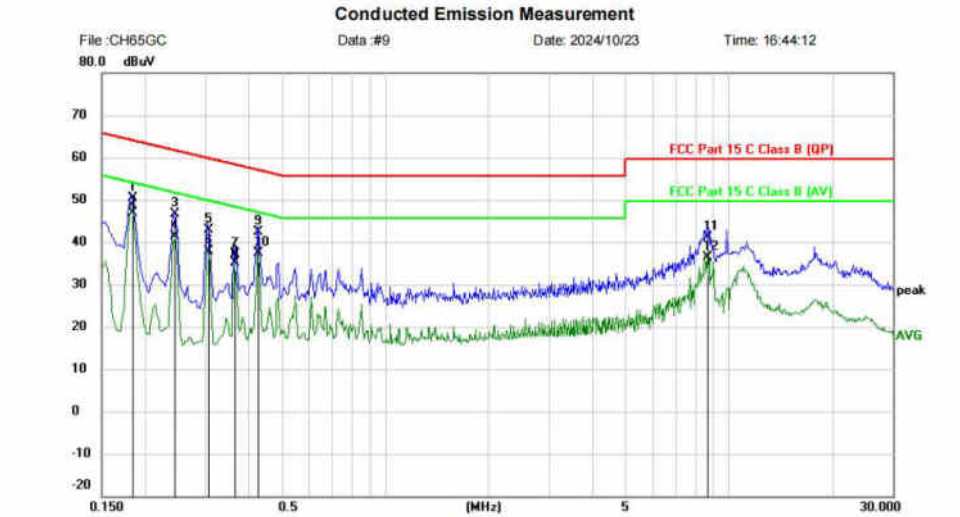

File :CH65GC Data :#9 Date: 2024/10/23 Time: 16:44:12
 Site Phase: **N** Temperature: 26
 Limit: FCC Part 15 C Class B (QP) Power: AC 120V/60Hz Humidity: 60 %
 EUT:
 M/N: CH65GC
 Mode: BLE
 Note:

No. Mk.	Freq. MHz	Reading Level dBuV	Correct Factor dB	Measurement dBuV	Limit dBuV	Over dB	Detector	Comment
1	0.1839	40.89	9.54	50.43	64.31	-13.88	QP	
2 *	0.1839	37.34	9.54	46.88	54.31	-7.43	AVG	
3	0.2443	36.95	9.56	46.51	61.95	-15.44	QP	
4	0.2443	31.76	9.56	41.32	51.95	-10.63	AVG	
5	0.3052	33.39	9.57	42.96	60.10	-17.14	QP	
6	0.3052	28.35	9.57	37.92	50.10	-12.18	AVG	
7	0.3667	27.57	9.58	37.15	58.58	-21.43	QP	
8	0.3667	25.60	9.58	35.18	48.58	-13.40	AVG	
9	0.4270	32.88	9.59	42.47	57.31	-14.84	QP	
10	0.4270	27.68	9.59	37.27	47.31	-10.04	AVG	
11	8.6756	31.21	9.95	41.16	60.00	-18.84	QP	
12	8.6756	26.50	9.95	36.45	50.00	-13.55	AVG	

Conducted Emission Measurement

File : CH65GC Data : #10 Date : 2024/10/23 Time : 16:49:27

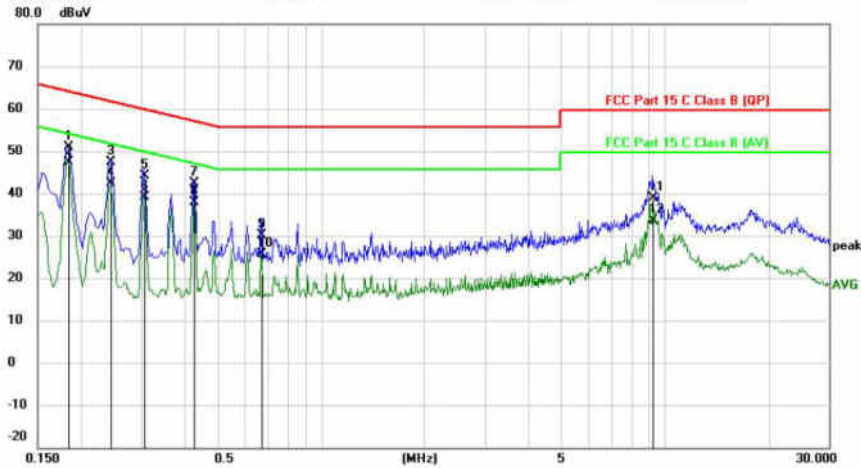

Site: Phase: **L1** Temperature: 26
 Limit: FCC Part 15 C Class B (QP) Power: AC 120V/60Hz Humidity: 60 %
 EUT:
 M/N: CH65GC
 Mode: BLE
 Note:

No. Mk.	Freq. MHz	Reading Level dBuV	Correct Factor dB	Measure- ment dBuV	Limit		Detector	Comment
					dBuV	dB		
1	0.1835	41.24	9.55	50.79	64.33	-13.54	QP	
2 *	0.1835	37.92	9.55	47.47	54.33	-6.86	AVG	
3	0.2443	37.75	9.57	47.32	61.95	-14.63	QP	
4	0.2443	32.80	9.57	42.37	51.95	-9.58	AVG	
5	0.3057	34.53	9.58	44.11	60.09	-15.98	QP	
6	0.3057	29.54	9.58	39.12	50.09	-10.97	AVG	
7	0.4269	32.81	9.60	42.41	57.31	-14.90	QP	
8	0.4269	28.27	9.60	37.87	47.31	-9.44	AVG	
9	0.6715	20.63	9.61	30.24	56.00	-25.76	QP	
10	0.6715	15.95	9.61	25.56	46.00	-20.44	AVG	
11	9.2190	28.82	9.95	38.77	60.00	-21.23	QP	
12	9.2190	23.80	9.95	33.75	50.00	-16.25	AVG	

Conducted Emission Measurement

File: CH75GC Data #12 Date: 2024/10/24 Time: 14:08:32

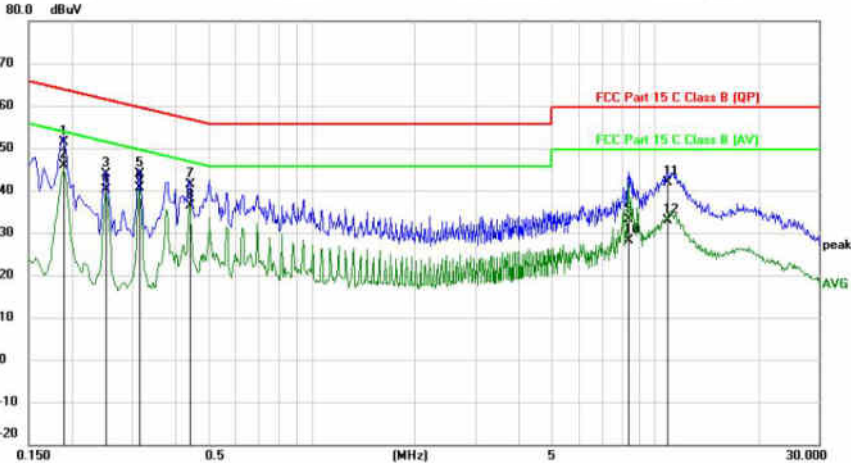

Site: _____ Phase: **L1** Temperature: 26
 Limit: FCC Part 15 C Class B (QP) Power: AC 120V/60Hz Humidity: 60 %
 EUT: _____
 M/N: CH75GC
 Mode: BLE
 Note: _____

No.	Mk.	Freq.	Reading Level	Correct Factor	Measurement	Limit	Over	Detector	Comment
		MHz	dBuV	dB	dBuV	dBuV	dB		
1		0.1889	41.73	9.55	51.28	64.08	-12.80	QP	
2	*	0.1889	36.35	9.55	45.90	54.08	-8.18	AVG	
3		0.2514	34.32	9.57	43.89	61.71	-17.82	QP	
4		0.2514	30.54	9.57	40.11	51.71	-11.60	AVG	
5		0.3154	34.40	9.58	43.98	59.83	-15.85	QP	
6		0.3154	31.02	9.58	40.60	49.83	-9.23	AVG	
7		0.4413	31.75	9.60	41.35	57.04	-15.69	QP	
8		0.4413	26.75	9.60	36.35	47.04	-10.69	AVG	
9		8.3333	23.11	9.93	33.04	60.00	-26.96	QP	
10		8.3333	18.26	9.93	28.19	50.00	-21.81	AVG	
11		10.7948	31.85	9.99	41.84	60.00	-18.16	QP	
12		10.7948	23.00	9.99	32.99	50.00	-17.01	AVG	

Conducted Emission Measurement

File :CH75GC Data #13 Date: 2024/10/24 Time: 14:12:24

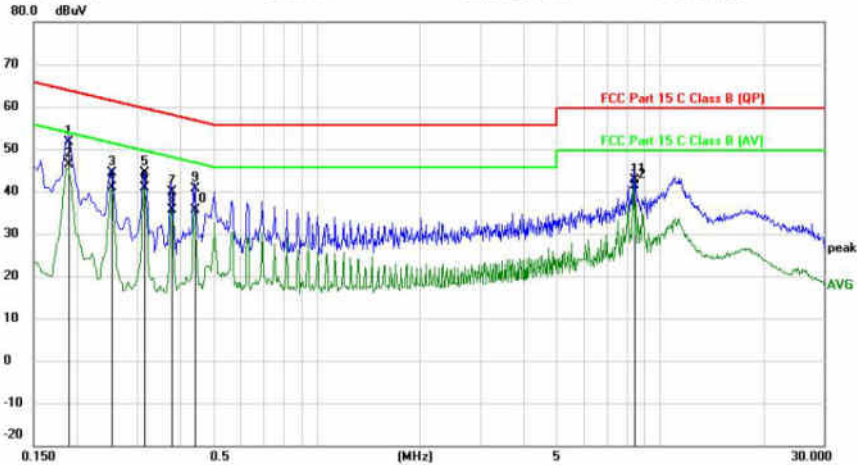

Site: Phase: **N** Temperature: 26
 Limit: FCC Part 15 C Class B (QP) Power: AC 120V/60Hz Humidity: 60 %
 EUT:
 M/N: CH75GC
 Mode: BLE
 Note:

No. Mk.	Freq. MHz	Reading Level dBuV	Correct Factor dB	Measure- ment dBuV	Limit dBuV	Over dB	Detector	Comment
1	0.1897	41.98	9.55	51.53	64.05	-12.52	QP	
2 *	0.1897	36.76	9.55	46.31	54.05	-7.74	AVG	
3	0.2525	34.91	9.57	44.48	61.67	-17.19	QP	
4	0.2525	31.25	9.57	40.82	51.67	-10.85	AVG	
5	0.3149	34.73	9.57	44.30	59.84	-15.54	QP	
6	0.3149	31.41	9.57	40.98	49.84	-8.86	AVG	
7	0.3787	30.38	9.58	39.96	58.31	-18.35	QP	
8	0.3787	26.12	9.58	35.70	48.31	-12.61	AVG	
9	0.4422	30.95	9.59	40.54	57.02	-16.48	QP	
10	0.4422	26.04	9.59	35.63	47.02	-11.39	AVG	
11	8.3695	32.63	9.93	42.56	60.00	-17.44	QP	
12	8.3695	31.51	9.93	41.44	50.00	-8.56	AVG	

END OF REPORT