

# SWIT<sup>®</sup>

SWIT Electronics Co., Ltd.

Ver: A

---

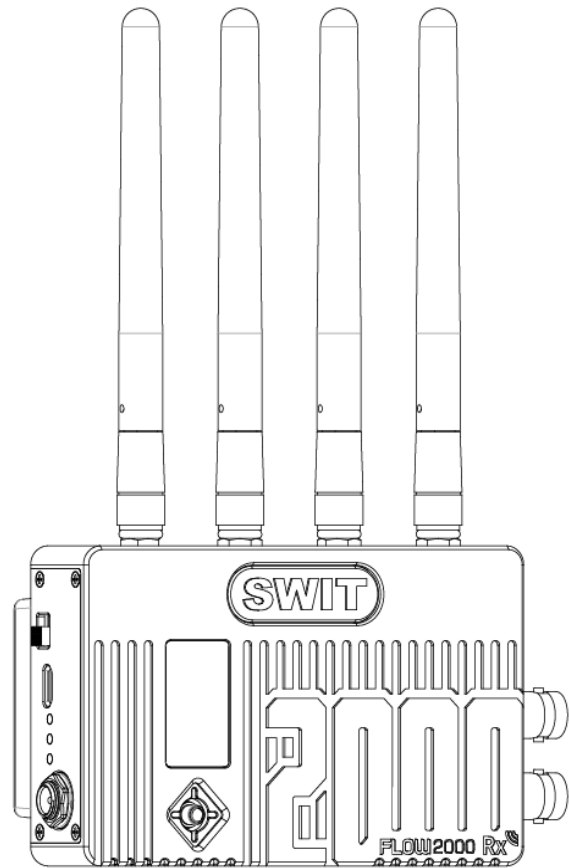
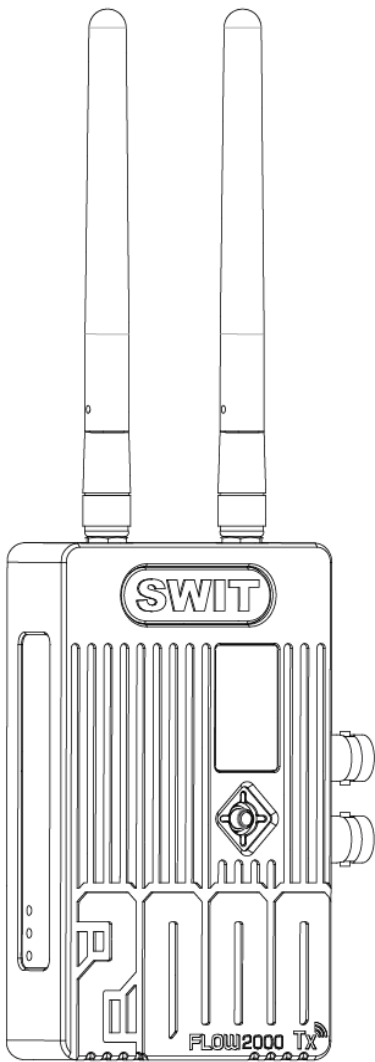

## User Manual

Please read this user manual  
throughout before using

## Preface

1. All internal technologies of this product are protected, including device, software and trademark. Reproduction in whole or in part without written permission is prohibited.
2. All brands and trademarks of SWIT Electronics Co., Ltd. are protected and other relative trademarks in this user manual are the property of their respective owners.
3. Due to constant effort of product development, SWIT reserves the right to make changes and improvements to the product described in this manual without prior notice.
4. The warranty period of this product is two years, and does not cover the following:
  - (1) Physical damage to the products
  - (2) Any damage or breakdown caused by use, maintenance, or storage not according to the user manual's introductions.
  - (3) The attenuation of signal quality resulting from being used in any special environments.
  - (4) Any damage caused by not powering the product by package supplied power adaptor.
  - (5) Any damage or breakdown not caused by the product's design, workmanship, manufacturing, quality, or unauthorized repairs or parts replacement or other operations.
5. For any suggestions and requirements on this products, please contact us through

---

### **SWIT Electronics Co., Ltd.**

Address: 10 Heng Tong Road, Xin'gang Economic and Technological Development Zone,

Nanjing 210038 China

Phone: +86-25-85805753

Fax: +86-25-85805296

Email: [contact@swit.cc](mailto:contact@swit.cc)

Website: <http://www.swit.cc>

## Safety Precautions

**Please follow the safety precautions before using. The following conditions are not covered by warranty.**

1. Unauthorized repairs or other Unauthorized operations.
2. Inappropriate placement including but not limited to lighting, fire, exposure to rain, water or gas.
3. Using the wrong power supply.



### Warning

- Do not get any liquid inside the products
- Do not block the ventilation openings or put substances inside, in order to avoid short circuit, fire or electric shock.
- Do not place the product in the rain or moisture to avoid electric shock or fire.



### Danger

- Switch the power off before connecting other devices.
- Power socket: Make sure the power socket under the voltage range of the product to avoid short circuit, electric shock and fire.
- Power cable: Make sure the power cable is not pressed or tightened by any items or weights.
- Power Load: Do not exceed the load on the wall outlet, extension cable or other porous receptacle to avoid fire or electric shock.
- Lightning: Disconnect the power cable if it is lightning or not using in a long period of time.

### Working Environment

- Please don't lay the product on any unstable place to avoid fallen damage.
- Please don't use the product in a place overheating, undercooling or with lots of moisture, or near by strong magnetic devices.
- Please don't lay the product on metal shelf, in order to ensure the effective wireless transmission.

### Packing list

This wireless system includes below accessories:

- |                  |               |                 |                                       |
|------------------|---------------|-----------------|---------------------------------------|
| 1. Transmitter   | 2.Receiver    | 3.Antenna*6     | 4.D-tap to lockable pole cable (0.6m) |
| 5. Power adaptor | 6.User manual | 7.Warranty card | 8. Articulating arm trestle           |

## 1. Product Introduction

FLOW2000 includes transmitter and receiver, adopts the latest encrypted transmission technology, and supports SDI and HDMI wirelessly transmitted in 600 meters scale (Line-of-Sight), 2 channels SDI/HDMI digital video transmission, auto pairing and OLED display. FLOW2000 is equipped with DC power connector, compact size, portable, and the receiving signal is very stable.

## 2. Features

### ◆ HD/SD-SDI and HDMI transmission

Support up to 1080p 50/60Hz SDI & HDMI wireless transmission.

### ◆ 600 meters transmission distance

In open outdoor area, the effective transmission distance is approx. 600 meters (line of sight).

### ◆ Wireless frequency

The system adopts 5180~5220MHz and 5760~5820MHz wireless frequency band(FLOW2000 Tx).

Channel	Frequency (MHz)	Channel	Frequency (MHz)
00	5180MHz	04	5780MHz
01	5200MHz	05	5800MHz
02	5220MHz	06	5820MHz
03	5760MHz	/	/

The system adopts 5182.5~5222.5MHz and 5762.5~5822.5MHz wireless frequency band(FLOW2000 Rx ).

Channel	Frequency (MHz)	Channel	Frequency (MHz)
00	5182.5	04	5782.5
01	5202.5	05	5802.5
02	5222.5	06	5822.5
03	5762.5	/	/

### ◆ Pairing mode

Support auto pairing connection and manual switching of frequency points. Support one transmitter to multi-receiver mode.

### ◆ OLED Display

Display the current working parameter, such as signal format, wireless channel, signal strength, and so on.

### ◆ Encryption

Support AES 128-bit encryption to protect the transmission.

### ◆ All-Metal Shell

Both the transmitter and receiver adopt metal shell which is durable and solid.

### ◆ All hardware design

The wireless system is hardware and plug-and-play designed, without installing software, easy to set up.

### Remark:

1. The transmission distance may be different, and depend on surroundings, radio wave conditions, buildings, etc., the 600 meters transmission distance may be not guaranteed.
2. The wireless transmission might be interrupted if there're many other devices of 5GHz wireless bandwidth Used in the same location.
3. Signal reception may be affected by the position, height and angle of devices. If reception video is not stable, please physically adjust placement for the optimized signal.
4. Set the antennas straight up and set receiver higher to enhance the transmission efficiency.
5. The product offers the AES 128-bit encryption to protect the wireless transmission. Please still be aware of the intentional signal interception from third person. Do not use it for important communication.

### 3. Appearance Instruction

#### Transmitter FLOW2000

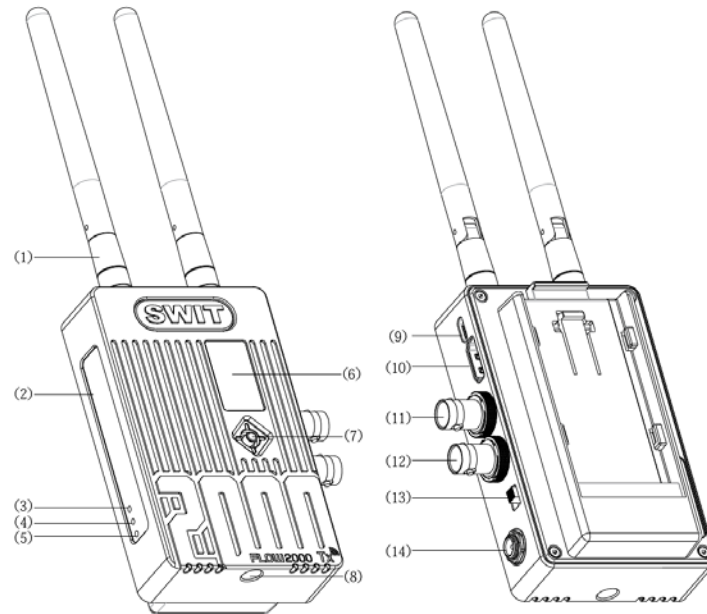

- (1) **Antenna**
- (2) **Product label**
- (3) **Link:** Wireless status indicator
- (4) **Video:** Video signal indicator
- (5) **Power:** Power status indicator
- (6) **OLED:** 0.96-inch OLED
- (7) **Five-direction switch:** Five-direction adjustment button (adjust the display menu to switch and confirm in five directions: up, down, left, right, and vertical)
- (8) **Installation thread:** 1/4"-20 thread. Use the package supplied articulating arm trestle to install the device to the camera.
- (9) **USB:** Micro USB, software upgrade interface
- (10) **HDMI in:** HDMI input (HDMI-A type connector)
- (11) **Battery plate:** "F" plates can be used. We recommend SWIT batteries like: S-8972, S-8970, S-8770, S-8975 compatible with SONY "L" series NP-F770/970.
- (12) **SDI LOOP:** SDI Loop out (BNC connector)
- (13) **SDI in:** SDI input (BNC connector)
- (14) **ON/OFF:** Power switch
- (15) **DC in:** Support DC 7-34V voltage input, 5.5mm (outer diameter) /2.1mm (inner diameter). Outside: negative, Inside: positive

## The description of LED status indicator

### Receiver FLOW2000

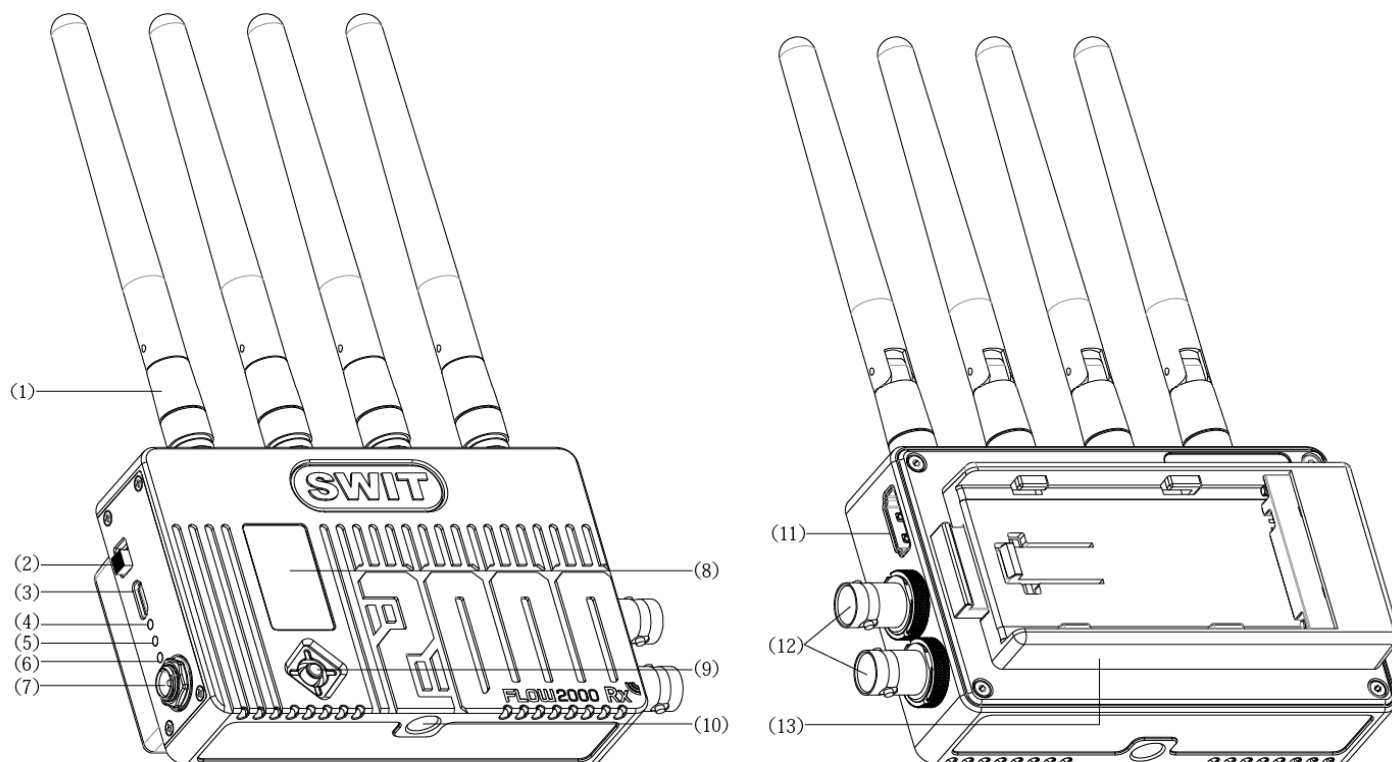

- (1) **Antenna**
- (2) **ON/OFF:** Power switch
- (3) **USB:** Micro USB, software upgrade interface
- (4) **Link:** Wireless status indicator
- (5) **Video:** Video signal indicator
- (6) **Power:** Power status indicator
- (7) **DC in:** Support DC 7-34V voltage input, 5.5mm (outer diameter) /2.1mm (inner diameter). Outside: negative, Inside: positive
- (8) **OLED:** 0.96-inch OLED
- (9) **Five-direction switch:** Five-direction adjustment button. (adjust the display menu to switch and confirm in five directions up, down, left, right, and vertical)
- (10) **Installation thread:** 1/4"-20 thread, Use the package supplied articulating arm trestle to install the device to the camera
- (11) **HDMI OUT:** HDMI output (HDMI-A type connector)
- (12) **SDI out:** SDI output (BNC connector)

Device	LED indicator	Status	Description
FLOW2000 Transmitter	Power	Constant On	Power connected and switched on
		Off	Power disconnected and switched off
	Video	Constant On	There is recognizable video signal input
		Flash	There is no recognizable video signal input
	Link	Constant On	The wireless network connection is normal
		Flash	The wireless network connection is abnormal

- (13) **Battery plate:** "F" plates can be used. We recommend SWIT batteries like: S-8972, S-8970, S-8770, S-8975 compatible with SONY "L" series NP-F770/970.

## The description of LED status indicator

### 4. OLED Display

#### Boot Screen

(When Tx and Rx both have no signal connection, Tx and Rx display the same. Fig.1)

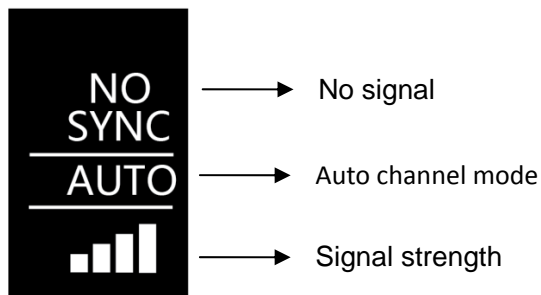

Fig.1

#### Main Screen

(When Tx and Rx have normal signal connection, Tx and Rx display the same. Fig.2)

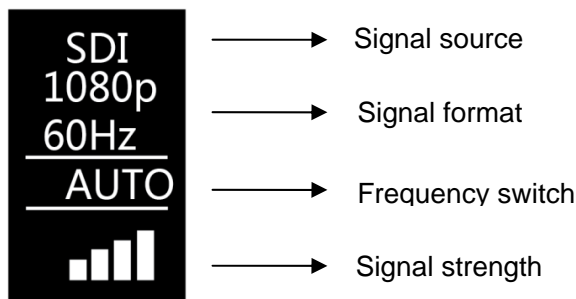

Fig.2

Remark: Channel switch is adjusted up or down by the red five-direction adjustment button under OLED, 7 wireless channels in total.

#### Switch Screen

a : (Transmitter : Push the red five-direction adjustment key at the bottom of the display screen. Fig 3 and Fig 5)

b : (Receiver : Push the red five-direction adjustment key at the bottom of the display screen . Fig 4 and Fig 5)

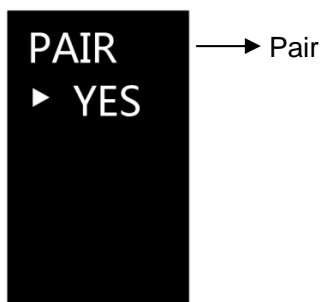

Fig.3

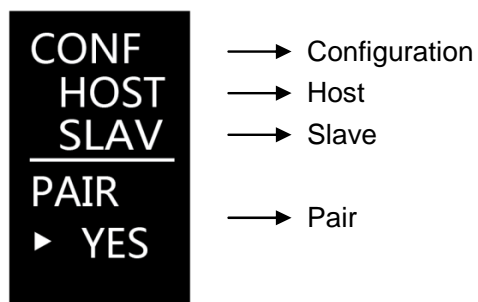

Fig.4

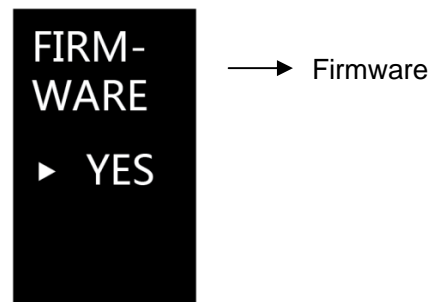

Fig.5

Remark:

1. The transmitter and receiver display different contents in the configuration setting interface: the transmitter only displays "PAIR", and the receiver displays "CONF", "PAIR" (Fig 3 , Fig 4).
2. In one transmitter to one receiver mode, receiver setting is "HOST" mode. In one transmitter to multi-receivers mode, one receiver setting is "HOST" mode, other receivers are all been set in "SLAV" mode. In one transmitter to multi-receivers mode, the "HOST" mode receiver must be on.
3. The setting default options of receiver "CONF" is "HOST". To set the "HOST" mode, push the five- direction

Device	LED indicator	Status	Description
FLOW2000 Receiver	Power	Constant On	Power connected and switched on
		Off	Power disconnected and switched off
	Video	Constant On	There is recognizable video signal input
		Flash	There is no recognizable video signal input
	Link	Constant On	The wireless network connection is normal
		Flash	The wireless network connection is abnormal

switch up and down, select "HOST" and press the five- direction switch. At the bottom of the screen, "PLEASE

REBOOT" prompts to REBOOT. After that, setting is ok.

4. To set several receivers to receive signal from one transmitter simultaneously (one transmitter to multi-receivers mode), we need to set all receivers except for "HOST" mode to "SLAV" mode, and then, push the five- direction switch up and down, select "SLAV" and press the five- direction switch. At the bottom of the screen, "PLEASE REBOOT" prompts to REBOOT. After that, setting is ok. The receiver which have been set to "SLAV" mode also need to be paired with corresponding transmitter, see details in manual "6. Pairing".

5. Support firmware upgrade via USB.

6. Both transmitter and receiver support manual switching of frequency points.

## 5. Setup connection

(1) Connect the SDI in/HDMI in interface of the FLOW2000 transmitter to the SDI out/HDMI out of the camera or video output device.

(2) Connect the SDI out/HDMI out interface of the FLOW2000 receiver to the SDI in/HDMI in of the monitor or switch station.

(3) Connect the Power supply of FLOW2000 transmitter and receiver, the "Power" light will light up, the OLED screen will display " WAIT..." , and then jump to the boot interface, as shown in figure 1. Start the machine and wait for a period of time. The transmitter and receiver have recognizable signal input and establish connection, and the "Link" and "Video" lights are constant on. If the transmitter and receiver have recognizable signal input but fail to establish a connection, the "Link" light will flash.

Remark:

1. When the FLOW2000 transmitter and receiver are powered, the power switch need to be set to "ON" .

2. FLOW2000 transmitter supports SDI input and HDMI input, and it will automatically detect the interface with input video.

If both SDI and HDMI have input signal, it will give priority to SDI video, and the corresponding receiver SDI/HDMI output interface output signal simultaneously.

## 6. Pairing

(1)Connect the "SDI in/HDMI in" interface of the FLOW2000 transmitter to the camera or video output device.

(2)Connect the SDI out/HDMI out interface of the FLOW2000 receiver to the SDI in/HDMI in of the monitor or switch station.

(3)Connect the FLOW2000 transmitter and receiver power supply, The "Power" light is on, waiting for the interface to jump to the main interface.

(4)Push the five-direction adjustment keys of the transmitter and receiver respectively to the right to the "PAIR" interface, the pairing interface of the transmitter shown in Fig 6; push down the five-direction adjustment key of the receiver to select "YES", as shown in Fig 7. Then press down the five-direction adjustment keys of the transmitter and receiver respectively to select "YES" to confirm the pairing. During the pairing, the "Link" lights of the transmitter and receiver flash quickly.

(5)After pairing successfully, the "Link" indicator stops flashing and enters the encrypted transmission state.



Fig.6



Fig.7

Remark:

1. When pairing, the transmitter and receiver need to be paired at the same time.

2. During normal use, ensure that the wireless device used has been paired and successfully paired.

3. The paired transmitter and receiver will be automatically connected after booting up. It is no need to pair again.

4. Please keep the transmitter and receiver in distance of 1-2m to avoid pairing failure.

5. Please do not use more than 4 groups of device under the same environment to avoid interference.



6. In one transmitter to multi-receivers mode, when "SLAV" mode receiver and transmitter are paired, the "HOST" mode receiver must be powered on.

## 7. The way to get the best effective of Wireless Transmission

(1)Set the antenna on both transmitter and receiver vertically straight up, no request to spread. If installed flat, still keep the antenna vertically straight up to extend transmission distance and stabilize transmission quality. (Fig.9)

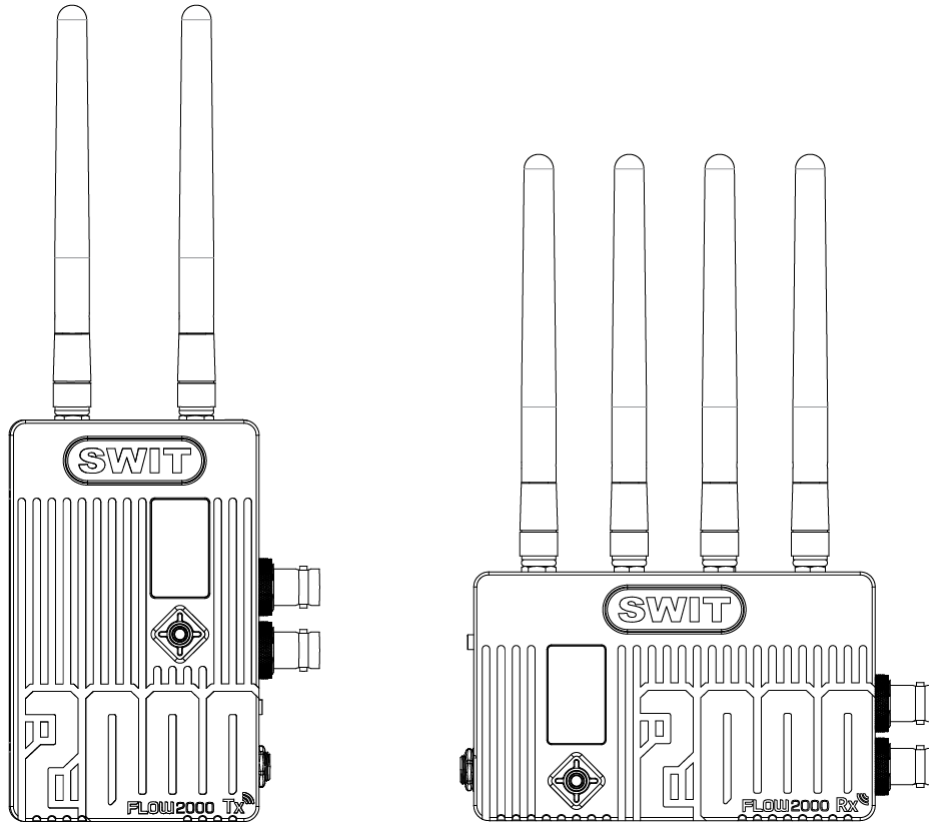
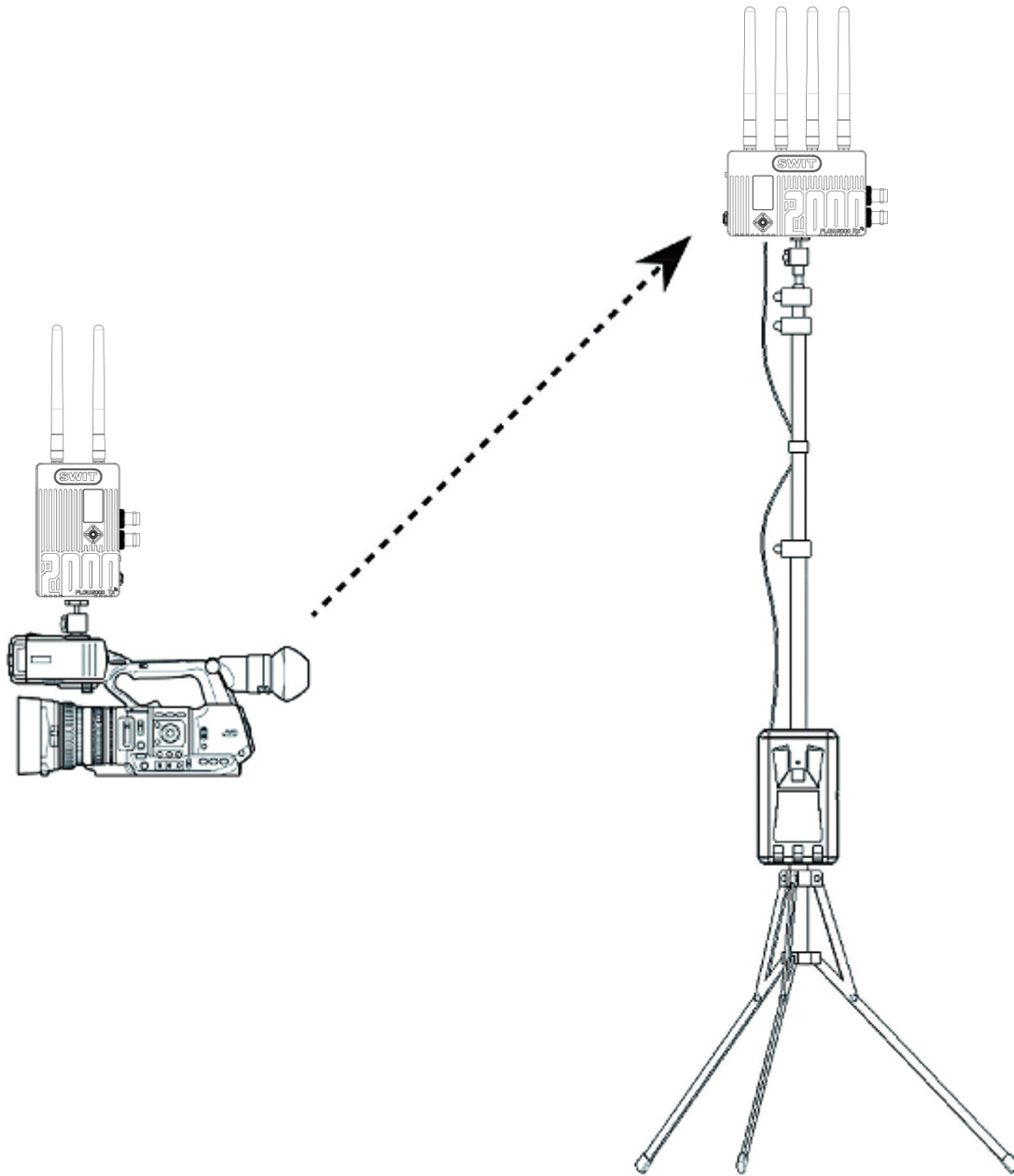
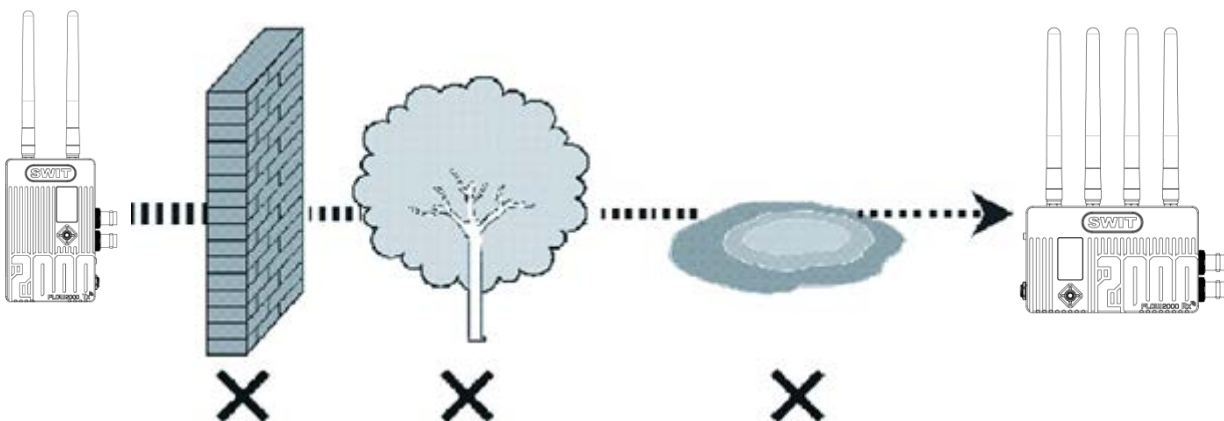

Fig.9

(2) Set the receiver as high as possible to avoid interference.



(3) Avoid walls, trees and water to reduce signal attenuation.



## 8. Trouble shooting

If the receiver failed to output video correctly, the possible causes are as below; please find the solution from following chart:

The receiving video	Possible causes	Solution
No display	The transmitter receiver is not powered on	Check power connection and switch on the transmitter and receiver
	The antennas are not installed properly and screwed tightly	Install the antennas properly and screw tightly of both transmitter and receiver
	Bad connection of video cable	Check video cable connection of both transmitter and receiver
	Video format is not supported	Change the output video format of the camera
Poor Video quality	Bad connection with video cable	Reconnect reliably
	The wireless transmission is disturbed by environment	Wait for 1 minute or reboot the transmitter and receiver
	The transmission distance is out of effective range	Close the transmitter to the receiver

## 9. Specification

Model	FLOW2000T Transmitter	FLOW2000R Receiver
Input	SDI×1、HDMI×1	/
Output	SDI×1	HDMI×1、SDI×2
Video format	1080I (60 / 59.94 / 50) / 1080PsF (24 / 23.98) / 720P (60 / 59.94 / 50) / 1080P (60 / 59.94 / 50 / 30 / 29.97 / 25 / 24 / 23.98)	
Wireless frequency	5180~5220MHz and 5760~5820MHz	
modulation mode	OFDM Support 16QAM, 64QAM, QPSK, BPSK modulation mode	
transmission distance	600m (Line of sight)	
Power consumption	≤8W	≤8W
Transmitting power	/	/
Human-Machine Interaction	0.96-inch OLED Monitor, Five-direction adjustment button	
Input voltage	DC / Battery: 7~34V	DC / Battery : 7~34V
Working environment	Temperature : 0℃~+40℃	
Dimension(without antenna and plate)	66×106.5×24.7 (mm)	106.5×66×24.7 (mm)
Net weight(without antenna)	236.0g	245.0g

## **FCC Statement**

Any Changes or modifications not expressly approved by the party responsible for compliance could void the user's authority to operate the equipment.

This device complies with part 15 of the FCC Rules. Operation is subject to the following two conditions:

- (1) This device may not cause harmful interference, and
- (2) This device must accept any interference received, including interference that may cause undesired operation.

### **FCC Radiation Exposure Statement:**

This equipment complies with FCC radiation exposure limits set forth for an uncontrolled environment .This equipment should be installed and operated with minimum distance 20cm between the radiator& your body.

Note : This equipment has been tested and found to comply with the limits for a Class B digital device, pursuant to part 15 of the FCC Rules. These limits are designed to provide reasonable protection against harmful interference in a residential installation. This equipment generates,uses and can radiate radio frequency energy and, if not installed and used in accordance with the instructions, may cause harmful interference to radio communications. However, there is no guarantee that interference will not occur in a particular installation. If this equipment does cause harmful interference to radio or television reception, which can be determined by turning the equipment off and on, the user is encouraged to try to correct the interference by one or more of the following measures:

- Reorient or relocate the receiving antenna.
- Increase the separation between the equipment and receiver.
- Connect the equipment into an outlet on a circuit different from that to which the receiver is connected.
- Consult the dealer or an experienced radio/TV technician for help.