

TEST REPORT

Application No.: SHEM1806004764CR
FCC ID: 2AFF6009PIUAM
Applicant: Adam Hall GmbH
Address of Applicant: Adam-Hall-Str. 1, 61267 Neu-Anspach, Germany
Manufacturer: Adam Hall GmbH
Address of Manufacturer: Adam-Hall-Str. 1, 61267 Neu-Anspach, Germany
Factory: Speaker Electronic (Jiashan) Co., Ltd
Address of Factory: No. 8 Development Zone Road, Huimin Sub-district, Jiashan County, Zhejiang, 314112, P.R. China

Equipment Under Test (EUT):

EUT Name: Active PA Box
Model No.: MAUI®P900
Trade mark: LD SYSTEMS
Standard(s) : 47 CFR Part 15, Subpart C 15.247
Date of Receipt: 2019-06-14
Date of Test: 2019-08-27 to 2019-08-29
Date of Issue: 2019-09-06

Test Result:	Pass*
---------------------	--------------

* In the configuration tested, the EUT complied with the standards specified above.

Parlam Zhan

Parlam Zhan
E&E Section Manager

The manufacturer should ensure that all products in series production are in conformity with the product sample detailed in this report. If the product in this report is used in any configuration other than that detailed in the report, the manufacturer must ensure the new system complies with all relevant standards. Any mention of SGS International Electrical Approvals or testing done by SGS International Electrical Approvals in connection with, distribution or use of the product described in this report must be approved by SGS International Electrical Approvals in writing.



Unless otherwise agreed in writing, this document is issued by the Company subject to its General Conditions of Service printed overleaf, available on request or accessible at <http://www.sgs.com/en/Terms-and-Conditions.aspx> and, for electronic format documents, subject to Terms and Conditions for Electronic Documents at <http://www.sgs.com/en/Terms-and-Conditions/Terms-e-Documents.aspx>. Attention is drawn to the limitation of liability, indemnification and jurisdiction issues defined therein. Any holder of this document is advised that information contained hereon reflects the Company's findings at the time of its intervention only and within the limits of Client's instructions, if any. The Company's sole responsibility is to its Client and this document does not exonerate parties to a transaction from exercising all their rights and obligations under the transaction documents. This document cannot be reproduced except in full, without prior written approval of the Company. Any unauthorized alteration, forgery or falsification of the content or appearance of this document is unlawful and offenders may be prosecuted to the fullest extent of the law. Unless otherwise stated the results shown in this test report refer only to the sample(s) tested and such sample(s) are retained for 30 days only.

Attention: To check the authenticity of testing /inspection report & certificate, please contact us at telephone: (86-755) 8307 1443, or email: CN.Doccheck@sgs.com

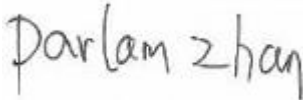

Revision Record			
Version	Description	Date	Remark
00	Original	2019-09-06	/

Authorized for issue by:			
			
		<hr/>	
		Bill Wu / Project Engineer	
			
		<hr/>	
		Parlam Zhan /Reviewer	



2 Test Summary

Radio Spectrum Technical Requirement				
Item	Standard	Method	Requirement	Result
Antenna Requirement	47 CFR Part 15, Subpart C 15.247	N/A	47 CFR Part 15, Subpart C 15.203 & 15.247(c)	Pass
Other requirements Frequency Hopping Spread Spectrum System Hopping Sequence	47 CFR Part 15, Subpart C 15.247	N/A	47 CFR Part 15, Subpart C 15.247(a)(1),(g),(h)	Pass

Radio Spectrum Matter Part				
Item	Standard	Method	Requirement	Result
Conducted Emissions at AC Power Line (150kHz-30MHz)	47 CFR Part 15, Subpart C 15.247	ANSI C63.10 (2013) Section 6.2	47 CFR Part 15, Subpart C 15.207	Pass
Conducted Peak Output Power	47 CFR Part 15, Subpart C 15.247	ANSI C63.10 (2013) Section 7.8.5	47 CFR Part 15, Subpart C 15.247(b)(1)	Pass
20dB Bandwidth	47 CFR Part 15, Subpart C 15.247	ANSI C63.10 (2013) Section 7.8.7	47 CFR Part 15, Subpart C 15.247(a)(1)	Pass
Carrier Frequencies Separation	47 CFR Part 15, Subpart C 15.247	ANSI C63.10 (2013) Section 7.8.2	47 CFR Part 15, Subpart C 15.247a(1)	Pass
Hopping Channel Number	47 CFR Part 15, Subpart C 15.247	ANSI C63.10 (2013) Section 7.8.3	47 CFR Part 15, Subpart C 15.247a(1)(iii)	Pass
Dwell Time	47 CFR Part 15, Subpart C 15.247	ANSI C63.10 (2013) Section 7.8.4	47 CFR Part 15, Subpart C 15.247a(1)(iii)	Pass
Conducted Band Edges Measurement	47 CFR Part 15, Subpart C 15.247	ANSI C63.10 (2013) Section 7.8.6	47 CFR Part 15, Subpart C 15.247(d)	Pass
Conducted Spurious Emissions	47 CFR Part 15, Subpart C 15.247	ANSI C63.10 (2013) Section 7.8.8	47 CFR Part 15, Subpart C 15.247(d)	Pass
Radiated Emissions which fall in the restricted bands	47 CFR Part 15, Subpart C 15.247	ANSI C63.10 (2013) Section 6.10.5	47 CFR Part 15, Subpart C 15.205 & 15.209	Pass
Radiated Spurious Emissions	47 CFR Part 15, Subpart C 15.247	ANSI C63.10 (2013) Section 6.4,6.5,6.6	47 CFR Part 15, Subpart C 15.205 & 15.209	Pass



3 Contents

	Page
1 COVER PAGE.....	1
2 TEST SUMMARY.....	3
3 CONTENTS.....	4
4 GENERAL INFORMATION	6
4.1 DETAILS OF E.U.T.....	6
4.2 DESCRIPTION OF SUPPORT UNITS.....	6
4.3 MEASUREMENT UNCERTAINTY	6
4.4 TEST LOCATION	7
4.5 TEST FACILITY	7
4.6 DEVIATION FROM STANDARDS	7
4.7 ABNORMALITIES FROM STANDARD CONDITIONS	7
5 EQUIPMENT LIST	8
6 RADIO SPECTRUM TECHNICAL REQUIREMENT	9
6.1 ANTENNA REQUIREMENT	9
6.1.1 <i>Test Requirement:</i>	9
6.1.2 <i>Conclusion:</i>	9
6.2 OTHER REQUIREMENTS FREQUENCY HOPPING SPREAD SPECTRUM SYSTEM HOPPING SEQUENCE	10
6.2.1 <i>Test Requirement:</i>	10
6.2.2 <i>Conclusion:</i>	10
7 RADIO SPECTRUM MATTER TEST RESULTS	11
7.1 CONDUCTED EMISSIONS AT AC POWER LINE (150kHz-30MHz).....	11
7.1.1 <i>E.U.T. Operation</i>	11
7.1.2 <i>Test Setup Diagram</i>	11
7.1.3 <i>Measurement Procedure and Data</i>	12
7.2 CONDUCTED PEAK OUTPUT POWER	15
7.2.1 <i>E.U.T. Operation</i>	15
7.2.2 <i>Test Setup Diagram</i>	15
7.2.3 <i>Measurement Procedure and Data</i>	15
7.3 20dB BANDWIDTH.....	16
7.3.1 <i>E.U.T. Operation</i>	16
7.3.2 <i>Test Setup Diagram</i>	16
7.3.3 <i>Measurement Procedure and Data</i>	16
7.4 CARRIER FREQUENCIES SEPARATION	17
7.4.1 <i>E.U.T. Operation</i>	17
7.4.2 <i>Test Setup Diagram</i>	17
7.4.3 <i>Measurement Procedure and Data</i>	17
7.5 HOPPING CHANNEL NUMBER	18
7.5.1 <i>E.U.T. Operation</i>	18
7.5.2 <i>Test Setup Diagram</i>	18
7.5.3 <i>Measurement Procedure and Data</i>	18
7.6 DWELL TIME	19
7.6.1 <i>E.U.T. Operation</i>	19
7.6.2 <i>Test Setup Diagram</i>	19
7.6.3 <i>Measurement Procedure and Data</i>	19
7.7 CONDUCTED BAND EDGES MEASUREMENT	20
7.7.1 <i>E.U.T. Operation</i>	21
7.7.2 <i>Test Setup Diagram</i>	21



7.7.3	Measurement Procedure and Data	21
7.8	CONDUCTED SPURIOUS EMISSIONS	22
7.8.1	E.U.T. Operation	22
7.8.2	Test Setup Diagram	22
7.8.3	Measurement Procedure and Data	22
7.9	RADIATED EMISSIONS WHICH FALL IN THE RESTRICTED BANDS.....	23
7.9.1	E.U.T. Operation	23
7.9.2	Test Setup Diagram	24
7.9.3	Measurement Procedure and Data	25
7.10	RADIATED SPURIOUS EMISSIONS	44
7.10.1	E.U.T. Operation	45
7.10.2	Test Setup Diagram	46
7.10.3	Measurement Procedure and Data.....	47
8	TEST SETUP PHOTOGRAPHS.....	51
9	EUT CONSTRUCTIONAL DETAILS.....	51

4 General Information

4.1 Details of E.U.T.

Power supply:	AC 100-120/200-240V,50/60Hz
Test voltage:	AC 120V/60Hz
Cable:	AC Cable 1.8m
Antenna Gain	2dBi
Antenna Type	Dipole Antenna
Channel Spacing	1MHz
Modulation Type	GFSK, $\pi/4$ DQPSK, 8DPSK
Number of Channels	79
Operation Frequency	2402MHz to 2480MHz
Spectrum Spread Technology	Frequency Hopping Spread Spectrum(FHSS)

4.2 Description of Support Units

Description	Manufacturer	Model No.	Serial No.
BT test board	/	Test Plate 2	/
Laptop	LENOVO	R400	/

4.3 Measurement Uncertainty

No.	Item	Measurement Uncertainty
1	Radio Frequency	7.25×10^{-8}
2	Timeout	2s
3	Duty cycle	0.37%
4	Occupied Bandwidth	3%
5	RF conducted power	0.75dB
6	RF power density	2.84dB
7	Conducted Spurious emissions	0.75dB
8	RF Radiated power	4.5dB (Below 1GHz)
		4.8dB (Above 1GHz)
9	Radiated Spurious emission test	4.2dB (Below 30MHz)
		4.4dB (30MHz-1GHz)
		4.6dB (1GHz-18GHz)
		5.2dB (Above 18GHz)
10	Temperature test	1°C
11	Humidity test	3%
12	Supply voltages	1.5%
13	Time	3%

Note: The measurement uncertainty represents an expanded uncertainty expressed at approximately the 95% confidence level using a coverage factor of $k=2$.



4.4 Test Location

All tests were performed at:

SGS-CSTC Standards Technical Services (Shanghai) Co., Ltd. E&E Lab
588 West Jindu Road, Xinqiao, Songjiang, 201612 Shanghai, China
Tel: +86 21 6191 5666 Fax: +86 21 6191 5678

No tests were sub-contracted.

4.5 Test Facility

The test facility is recognized, certified, or accredited by the following organizations:

• **CNAS (No. CNAS L0599)**

CNAS has accredited SGS-CSTC Standards Technical Services (Shanghai) Co., Ltd. to ISO/IEC 17025:2005 General Requirements for the Competence of Testing and Calibration Laboratories (CNAS-CL01 Accreditation Criteria for the Competence of Testing and Calibration Laboratories) for the competence in the field of testing.

• **NVLAP (Certificate No. 201034-0)**

SGS-CSTC Standards Technical Services (Shanghai) Co., Ltd. is accredited by the National Voluntary Laboratory Accreditation Program(NVLAP). Certificate No. 201034-0.

• **FCC –Designation Number: CN5033**

SGS-CSTC Standards Technical Services (Shanghai) Co., Ltd. has been recognized as an accredited testing laboratory.

Designation Number: CN5033. Test Firm Registration Number: 479755.

• **Industry Canada (IC) – IC Assigned Code: 8617A**

The 3m Semi-anechoic chamber of SGS-CSTC Standards Technical Services (Shanghai) Co., Ltd. has been registered by Certification and Engineering Bureau of Industry Canada for radio equipment testing with Registration No.: 8617A-1.

• **VCCI (Member No.: 3061)**

The 3m Semi-anechoic chamber and Shielded Room of SGS-CSTC Standards Technical Services (Shanghai) Co., Ltd. has been registered in accordance with the Regulations for Voluntary Control Measures with Registration No.: R-13868, C-14336, T-12221, G-10830 respectively.

4.6 Deviation from Standards

None

4.7 Abnormalities from Standard Conditions

None

5 Equipment List

Equipment	Manufacturer	Model No	Inventory No	Cal Date	Cal Due Date
Conducted Emission at AC Power Line					
EMI test receiver	R&S	ESR7	SHEM162-1	2018-12-20	2019-12-19
LISN	Schwarzbeck	NSLK8127	SHEM061-1	2018-12-20	2019-12-19
LISN	EMCO	3816/2	SHEM019-1	2018-12-20	2019-12-19
Pulse limiter	R&S	ESH3-Z2	SHEM029-1	2018-12-20	2019-12-19
CE test Cable	/	CE01	/	2018-12-26	2019-12-25
Conducted Test					
Spectrum Analyzer	R&S	FSP-30	SHEM002-1	2018-12-20	2019-12-19
Spectrum Analyzer	Agilent	N9020A	SHEM181-1	2019-08-13	2020-08-12
Signal Generator	R&S	SMR20	SHEM006-1	2019-08-13	2020-08-12
Signal Generator	Agilent	N5182A	SHEM182-1	2019-08-13	2020-08-12
Communication Tester	R&S	CMW270	SHEM183-1	2019-08-13	2020-08-12
Switcher	Tonscend	JS0806	SHEM184-1	2019-08-13	2020-08-12
Power Sensor	Keysight	U2021XA * 4	SHEM184-1	2019-08-13	2020-08-12
Splitter	Anritsu	MA1612A	SHEM185-1	/	/
Coupler	e-meca	803-S-1	SHEM186-1	/	/
High-low Temp Cabinet	Suzhou Zhihe	TL-40	SHEM087-1	2019-08-13	2020-08-12
AC Power Stabilizer	WOCEN	6100	SHEM045-1	2018-12-26	2019-12-25
DC Power Supply	QJE	QJ30003SII	SHEM046-1	2018-12-26	2019-12-25
Conducted test Cable	/	RF01~RF04	/	2018-12-26	2019-12-25
Radiated Test					
EMI test Receiver	R&S	ESU40	SHEM051-1	2018-12-20	2019-12-19
Spectrum Analyzer	R&S	FSP-30	SHEM002-1	2018-12-20	2019-12-19
Loop Antenna (9kHz-30MHz)	Schwarzbeck	FMZB1519	SHEM135-1	2017-04-10	2020-04-09
Antenna (25MHz-2GHz)	Schwarzbeck	VULB9168	SHEM048-1	2017-02-28	2020-02-27
Antenna (25MHz-3GHz)	Schwarzbeck	HL562	SHEM010-1	2017-02-28	2020-02-27
Horn Antenna (1-8GHz)	Schwarzbeck	HF906	SHEM009-1	2017-10-24	2020-10-23
Horn Antenna (1-18GHz)	Schwarzbeck	BBHA9120D	SHEM050-1	2017-01-14	2020-01-13
Horn Antenna (14-40GHz)	Schwarzbeck	BBHA 9170	SHEM049-1	2017-12-03	2020-12-02
Pre-amplifier (9kHz-2GHz)	CLAVIIO	BDLNA-0001	SHEM164-1	2019-08-13	2020-08-12
Pre-amplifier (1-18GHz)	CLAVIIO	BDLNA-0118	SHEM050-2	2019-08-13	2020-08-12
High-amplifier (14-40GHz)	Schwarzbeck	10001	SHEM049-2	2018-12-20	2019-12-19
Signal Generator	R&S	SMR40	SHEM058-1	2019-08-13	2020-08-12
Band Filter	LORCH	9BRX-875/X150	SHEM156-1	/	/
Band Filter	LORCH	13BRX-1950/X500	SHEM083-2	/	/
Band Filter	LORCH	5BRX-2400/X200	SHEM155-1	/	/
Band Filter	LORCH	5BRX-5500/X1000	SHEM157-2	/	/
High pass Filter	Wainwright	WHK3.0/18G	SHEM157-1	/	/
High pass Filter	Wainwright	WHKS1700	SHEM157-3	/	/
Semi/Fully Anechoic	ST	11*6*6M	SHEM078-2	2017-07-22	2020-07-21
RE test Cable	/	RE01, RE02, RE06	/	2018-12-26	2019-12-25

6 Radio Spectrum Technical Requirement

6.1 Antenna Requirement

6.1.1 Test Requirement:

47 CFR Part 15, Subpart C 15.203 & 15.247(c)

6.1.2 Conclusion

Standard Requirement:

An intentional radiator shall be designed to ensure that no antenna other than that furnished by the responsible party shall be used with the device. The use of a permanently attached antenna or of an antenna that uses a unique coupling to the intentional radiator, the manufacturer may design the unit so that a broken antenna can be replaced by the user, but the use of a standard antenna jack or electrical connector is prohibited.

15.247(b) (4) requirement:

The conducted output power limit specified in paragraph (b) of this section is based on the use of antennas with directional gains that do not exceed 6 dBi. Except as shown in paragraph (c) of this section, if transmitting antennas of directional gain greater than 6 dBi are used, the conducted output power from the intentional radiator shall be reduced below the stated values in paragraphs (b)(1), (b)(2), and (b)(3) of this section, as appropriate, by the amount in dB that the directional gain of the antenna exceeds 6 dBi.

EUT Antenna:

The antenna is Dipole antenna and no consideration of replacement. The best case gain of the antenna is 2dBi.

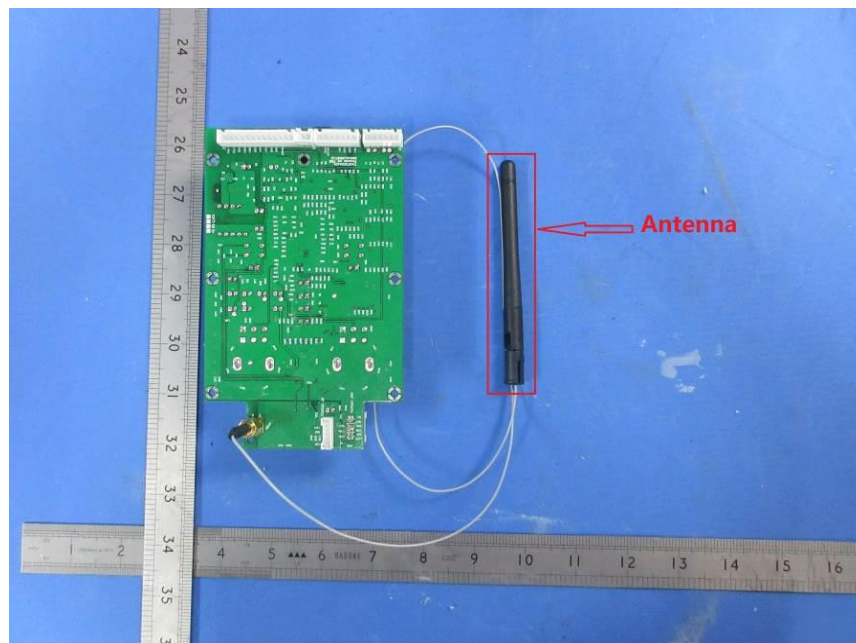



6.2 Other requirements Frequency Hopping Spread Spectrum System Hopping Sequence

6.2.1 Test Requirement:

47 CFR Part 15, Subpart C 15.247(a)(1),(g),(h)

6.2.2 Conclusion

Standard Requirement:

The system shall hop to channel frequencies that are selected at the system hopping rate from a Pseudorandom ordered list of hopping frequencies. Each frequency must be used equally on the average by each transmitter. The system receivers shall have input bandwidths that match the hopping channel bandwidths of their corresponding transmitters and shall shift frequencies in synchronization with the transmitted signals.

Frequency hopping spread spectrum systems are not required to employ all available hopping channels during each transmission. However, the system, consisting of both the transmitter and the receiver, must be designed to comply with all of the regulations in this section should the transmitter be presented with a continuous data (or information) stream. In addition, a system employing short transmission bursts must comply with the definition of a frequency hopping system and must distribute its transmissions over the minimum number of hopping channels specified in this section.

The incorporation of intelligence within a frequency hopping spread spectrum system that permits the system to recognize other users within the spectrum band so that it individually and independently chooses and adapts its hopsets to avoid hopping on occupied channels is permitted. The coordination of frequency hopping systems in any other manner for the express purpose of avoiding the simultaneous occupancy of individual hopping frequencies by multiple transmitters is not permitted.

Compliance for section 15.247(a)(1):

According to Technical Specification, the pseudorandom sequence may be generated in a nine-stage shift register whose 5th and 9th stage outputs are added in a modulo-two addition stage. And the result is fed back to the input of the first stage. The sequence begins with the first ONE of 9 consecutive ONES; i.e. the shift register is initialized with nine ones.

> Number of shift register stages: 9

> Length of pseudo-random sequence: $29 - 1 = 511$ bits

> Longest sequence of zeros: 8 (non-inverted signal)

Linear Feedback Shift Register for Generation of the PRBS sequence

An example of Pseudorandom Frequency Hopping Sequence as follow:

Each frequency used equally on the average by each transmitter.

According to Technical Specification, the receivers are designed to have input and IF bandwidths that match the hopping channel bandwidths of any transmitters and shift frequencies in synchronization with the transmitted signals.

Compliance for section 15.247(g):

According to Technical Specification, the system transmits the packet with the pseudorandom hopping frequency with a continuous data and the short burst transmission from the Bluetooth system is also transmitted under the frequency hopping system with the pseudorandom hopping frequency system.

Compliance for section 15.247(h):

According to Technical specification, the system incorporates with an adaptive system to detect other user within the spectrum band s

7 Radio Spectrum Matter Test Results

7.1 Conducted Emissions at AC Power Line (150kHz-30MHz)

Test Requirement 47 CFR Part 15, Subpart C 15.207

Test Method: ANSI C63.10 (2013) Section 6.2

Limit:

Frequency of emission(MHz)	Conducted limit(dB μ V)	
	Quasi-peak	Average
0.15-0.5	66 to 56*	56 to 46*
0.5-5	56	46
5-30	60	50

*Decreases with the logarithm of the frequency.

7.1.1 E.U.T. Operation

Operating Environment:

Temperature: 22 °C Humidity: 50 % RH Atmospheric Pressure: 1002 mbar

Test mode b:TX_non-Hop mode_Keep the EUT in continuously transmitting mode with GFSK modulation, $\pi/4$ DQPSK modulation, 8DPSK modulation. All modes have been tested and only the data of worst case is recorded in the report.

7.1.2 Test Setup Diagram

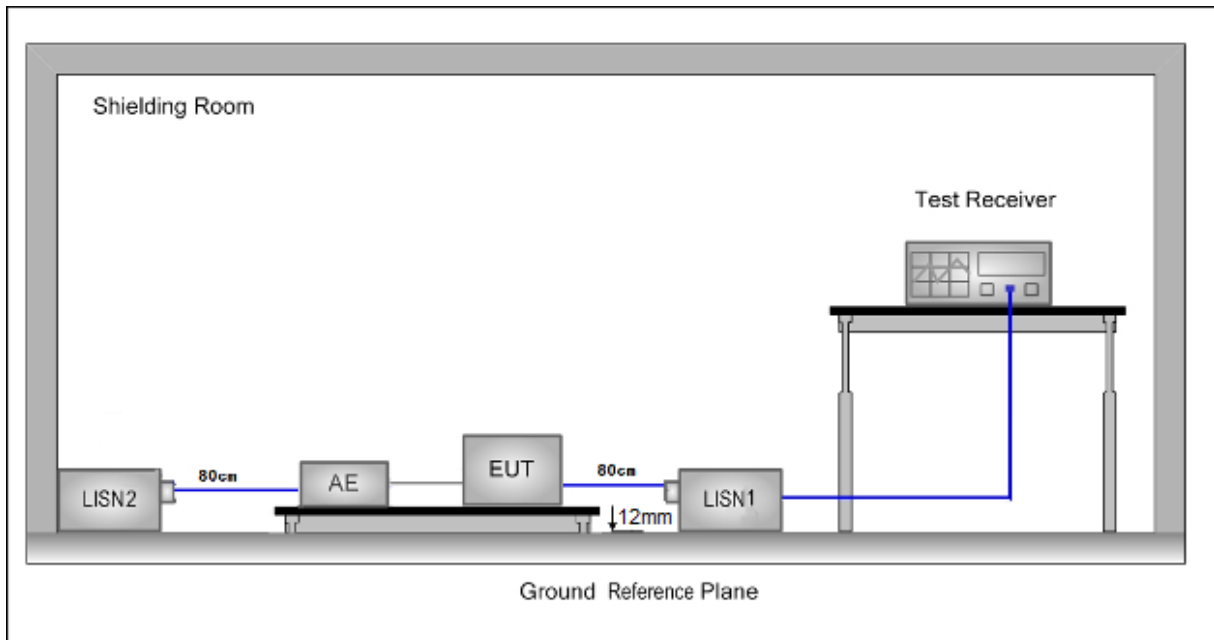



7.1.3 Measurement Procedure and Data

- 1) The mains terminal disturbance voltage test was conducted in a shielded room.
- 2) The EUT was connected to AC power source through a LISN 1 (Line Impedance Stabilization Network) which provides a 50ohm/50μH + 5ohm linear impedance. The power cables of all other units of the EUT were connected to a second LISN 2, which was bonded to the ground reference plane in the same way as the LISN 1 for the unit being measured. A multiple socket outlet strip was used to connect multiple power cables to a single LISN provided the rating of the LISN was not exceeded.
- 3) The tabletop EUT was placed upon a non-metallic table 0.8m above the ground reference plane. And for floor-standing arrangement, the EUT was placed on the horizontal ground reference plane,
- 4) The test was performed with a vertical ground reference plane. The rear of the EUT shall be 0.4 m from the vertical ground reference plane. The vertical ground reference plane was bonded to the horizontal ground reference plane. The LISN 1 was placed 0.8 m from the boundary of the unit under test and bonded to a ground reference plane for LISNs mounted on top of the ground reference plane. This distance was between the closest points of the LISN 1 and the EUT. All other units of the EUT and associated equipment was at least 0.8 m from the LISN 2.
- 5) In order to find the maximum emission, the relative positions of equipment and all of the interface cables must be changed according to ANSI C63.10 on conducted measurement.

Remark: LISN=Read Level+ Cable Loss+ LISN Factor

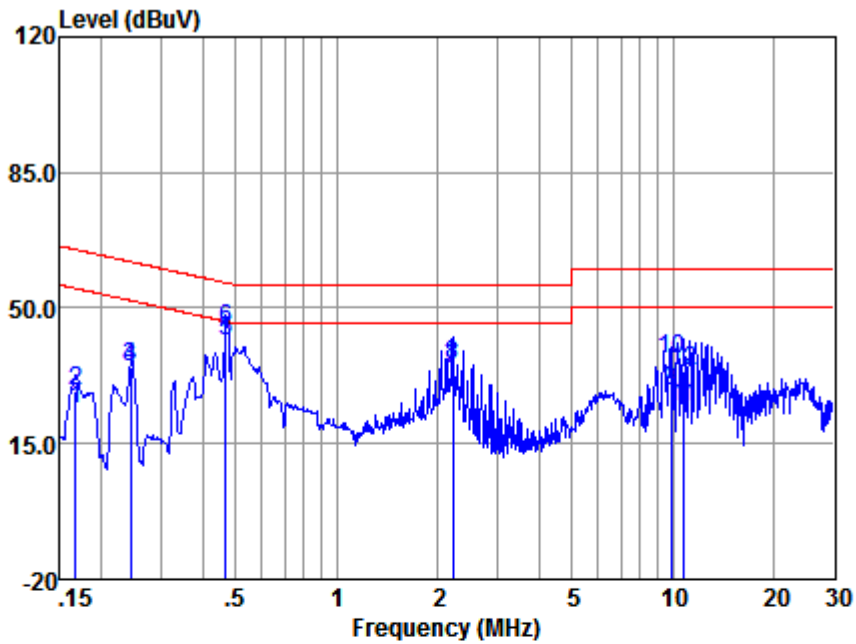

LISN : LINE

Test Mode : b

	Freq (MHz)	Read level (dBuV)	LISN Factor (dB)	Cable Loss (dB)	Emission Level (dBuV)	Limit (dBuV)	Over Limit (dB)	Remark
1	0.17	13.93	0.11	9.83	23.87	55.08	-31.21	Average
2	0.17	18.69	0.11	9.83	28.63	65.08	-36.45	QP
3	0.24	24.56	0.11	9.85	34.52	51.95	-17.43	Average
4	0.24	25.04	0.11	9.85	35.00	61.95	-26.95	QP
5	0.47	31.39	0.11	9.82	41.32	46.54	-5.22	Average
6	0.47	34.51	0.11	9.82	44.44	56.54	-12.10	QP
7	2.21	24.34	0.12	9.85	34.31	46.00	-11.69	Average
8	2.21	25.46	0.12	9.85	35.43	56.00	-20.57	QP
9	9.86	18.62	0.10	9.76	28.48	50.00	-21.52	Average
10	9.86	27.16	0.10	9.76	37.02	60.00	-22.98	QP
11	10.79	14.42	0.11	9.79	24.32	50.00	-25.68	Average
12	10.79	23.82	0.11	9.79	33.72	60.00	-26.28	QP

Notes: Emission Level = Read Level + LISN Factor + Cable loss

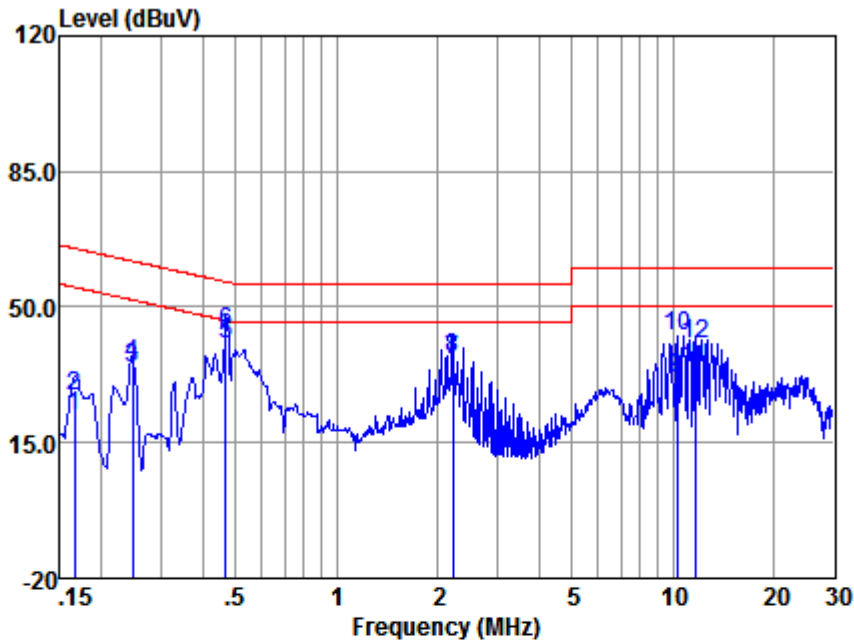

LISN : NEUTRAL

Test Mode : b

	Freq (MHz)	Read level (dBuV)	LISN Factor (dB)	Cable Loss (dB)	Emission Level (dBuV)	Limit (dBuV)	Over Limit (dB)	Remark
1	0.17	11.81	0.12	9.83	21.76	55.16	-33.40	Average
2	0.17	17.26	0.12	9.83	27.21	65.16	-37.95	QP
3	0.25	24.51	0.11	9.85	34.47	51.86	-17.39	Average
4	0.25	25.50	0.11	9.85	35.46	61.86	-26.40	QP
5	0.47	30.57	0.11	9.82	40.50	46.54	-6.04	Average
6	0.47	33.44	0.11	9.82	43.37	56.54	-13.17	QP
7	2.21	26.12	0.12	9.85	36.09	46.00	-9.91	Average
8	2.21	26.74	0.12	9.85	36.71	56.00	-19.29	QP
9	10.29	21.69	0.13	9.68	31.50	50.00	-18.50	Average
10	10.29	32.54	0.13	9.68	42.35	60.00	-17.65	QP
11	11.68	24.38	0.15	9.85	34.38	50.00	-15.62	Average
12	11.68	30.68	0.15	9.85	40.68	60.00	-19.32	QP

Notes: Emission Level = Read Level + LISN Factor + Cable loss

7.2 Conducted Peak Output Power

Test Requirement 47 CFR Part 15, Subpart C 15.247(b)(1)

Test Method: ANSI C63.10 (2013) Section 7.8.5

Limit:

Frequency range(MHz)	Output power of the intentional radiator(watt)
902-928	1 for ≥ 50 hopping channels
	0.25 for $25 \leq$ hopping channels < 50
	1 for digital modulation
2400-2483.5	1 for ≥ 75 non-overlapping hopping channels
	0.125 for all other frequency hopping systems
	1 for digital modulation
5725-5850	1 for frequency hopping systems and digital modulation

7.2.1 E.U.T. Operation

Operating Environment:

Temperature: 22 °C Humidity: 50 % RH Atmospheric Pressure: 1002 mbar

Test mode b:TX_non-Hop mode_Keep the EUT in continuously transmitting mode with GFSK modulation, $\pi/4$ DQPSK modulation, 8DPSK modulation. All modes have been tested and only the data of worst case is recorded in the report.

7.2.2 Test Setup Diagram

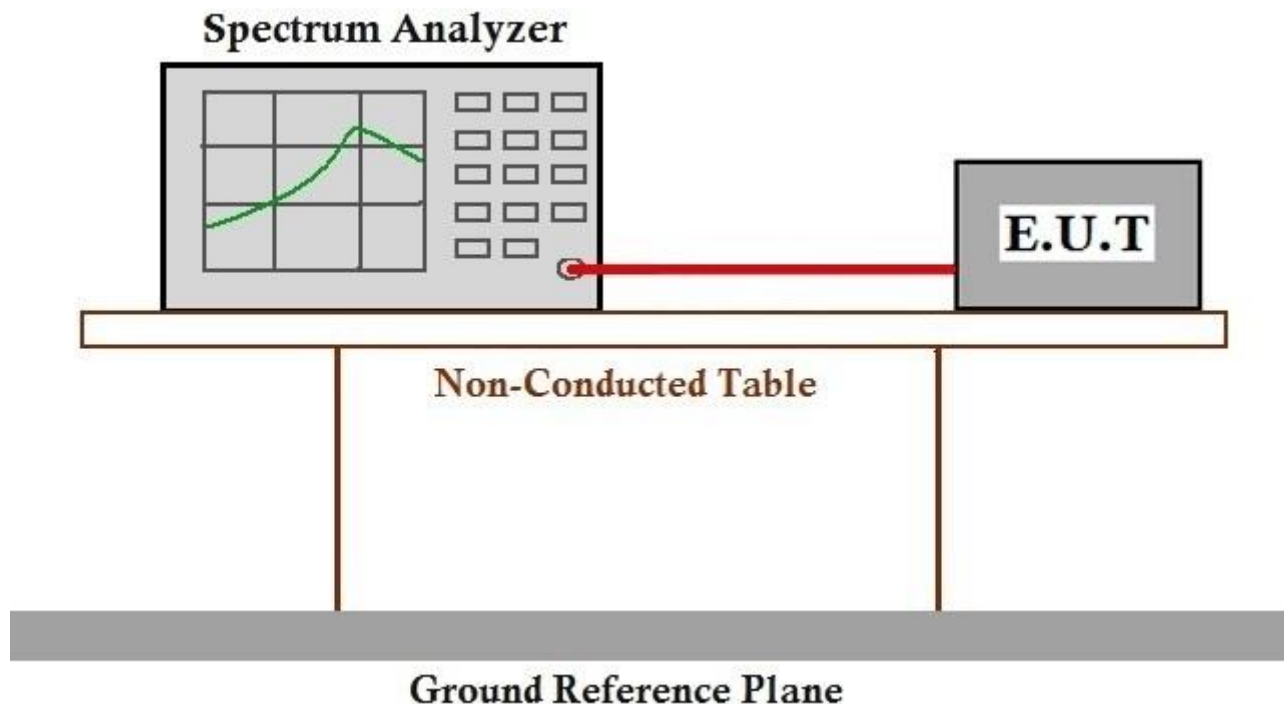

7.2.3 Measurement Procedure and Data

The detailed test data see: Appendix A SHEM180600476401

7.3 20dB Bandwidth

Test Requirement 47 CFR Part 15, Subpart C 15.247(a)(1)

Test Method: ANSI C63.10 (2013) Section 7.8.7

7.3.1 E.U.T. Operation

Operating Environment:

Temperature: 22 °C Humidity: 50 % RH Atmospheric Pressure: 1002 mbar

Test mode b:TX_non-Hop mode_Keep the EUT in continuously transmitting mode with GFSK modulation, $\pi/4$ DQPSK modulation, 8DPSK modulation. All modes have been tested and only the data of worst case is recorded in the report.

7.3.2 Test Setup Diagram

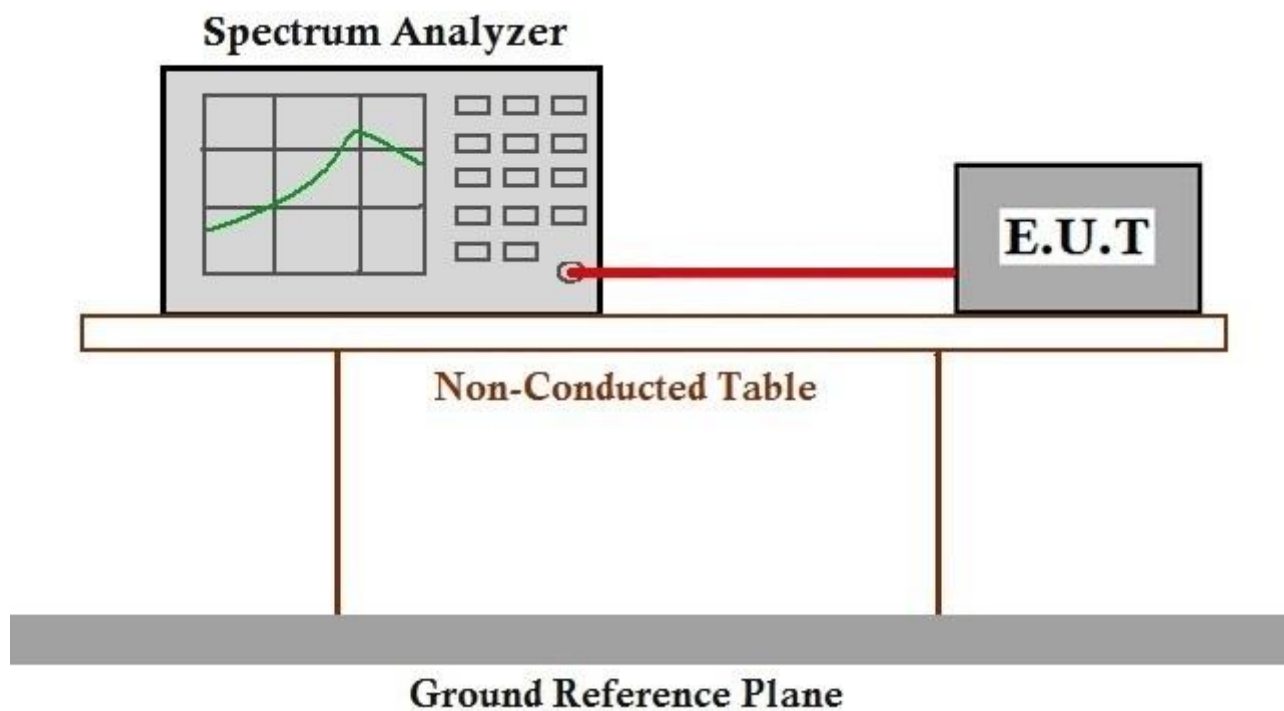

7.3.3 Measurement Procedure and Data

The detailed test data see: Appendix A SHEM180600476401

7.4 Carrier Frequencies Separation

Test Requirement 47 CFR Part 15, Subpart C 15.247a(1)
 Test Method: ANSI C63.10 (2013) Section 7.8.2
 Limit: 2/3 of the 20dB bandwidth base on the transmission power is less than 0.125W

7.4.1 E.U.T. Operation

Operating Environment:

Temperature: 22 °C Humidity: 50 % RH Atmospheric Pressure: 1002 mbar

Test mode a:TX_Hop mode_Keep the EUT in frequency hopping mode with GFSK modulation, $\pi/4$ DQPSK modulation, 8DPSK modulation. All modes have been tested and only the data of worst case is recorded in the report.

7.4.2 Test Setup Diagram

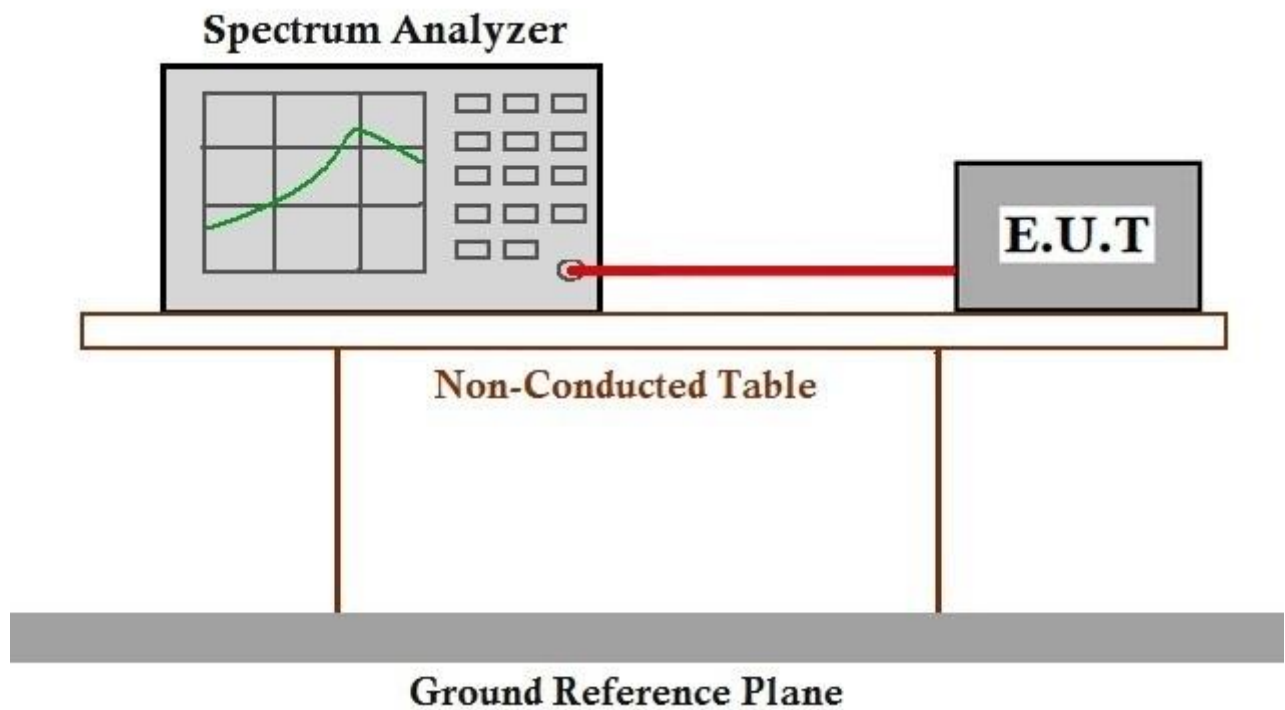

7.4.3 Measurement Procedure and Data

The detailed test data see: Appendix A SHEM180600476401

7.5 Hopping Channel Number

Test Requirement 47 CFR Part 15, Subpart C 15.247a(1)(iii)

Test Method: ANSI C63.10 (2013) Section 7.8.3

Limit:

Frequency range(MHz)	Number of hopping channels (minimum)
902-928	50 for 20dB bandwidth <250kHz
	25 for 20dB bandwidth ≥250kHz
2400-2483.5	15
5725-5850	75

7.5.1 E.U.T. Operation

Operating Environment:

Temperature: 22 °C Humidity: 50 % RH Atmospheric Pressure: 1002 mbar

Test mode a:TX_Hop mode_Keep the EUT in frequency hopping mode with GFSK modulation, $\pi/4$ DQPSK modulation, 8DPSK modulation. All modes have been tested and only the data of worst case is recorded in the report.

7.5.2 Test Setup Diagram

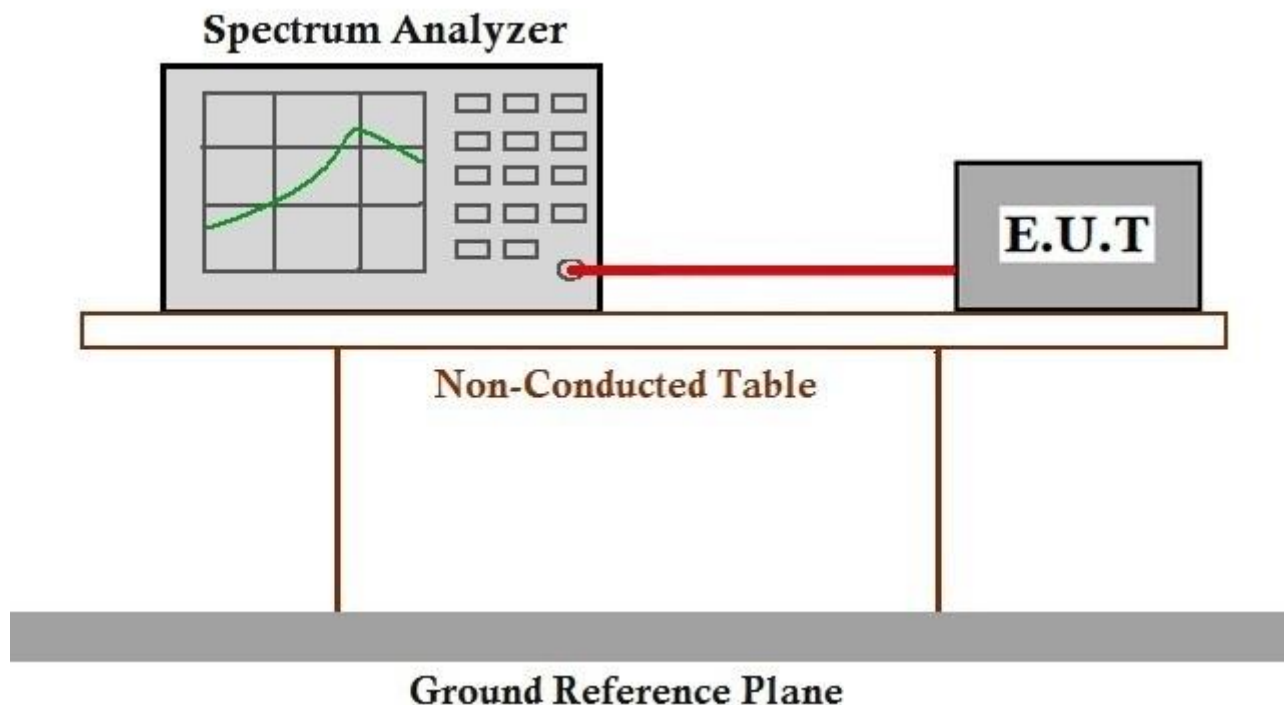

7.5.3 Measurement Procedure and Data

The detailed test data see: Appendix A SHEM180600476401

7.6 Dwell Time

Test Requirement 47 CFR Part 15, Subpart C 15.247a(1)(iii)

Test Method: ANSI C63.10 (2013) Section 7.8.4

Limit:

Frequency(MHz)	Limit
902-928	0.4S within a 20S period(20dB bandwidth<250kHz)
	0.4S within a 10S period(20dB bandwidth≥250kHz)
2400-2483.5	0.4S within a period of 0.4S multiplied by the number of hopping channels
5725-5850	0.4S within a 30S period

7.6.1 E.U.T. Operation

Operating Environment:

Temperature: 22 °C Humidity: 50 % RH Atmospheric Pressure: 1002 mbar

Test mode a:TX_Hop mode_Keep the EUT in frequency hopping mode with GFSK modulation, $\pi/4$ DQPSK modulation, 8DPSK modulation. All modes have been tested and only the data of worst case is recorded in the report.

7.6.2 Test Setup Diagram

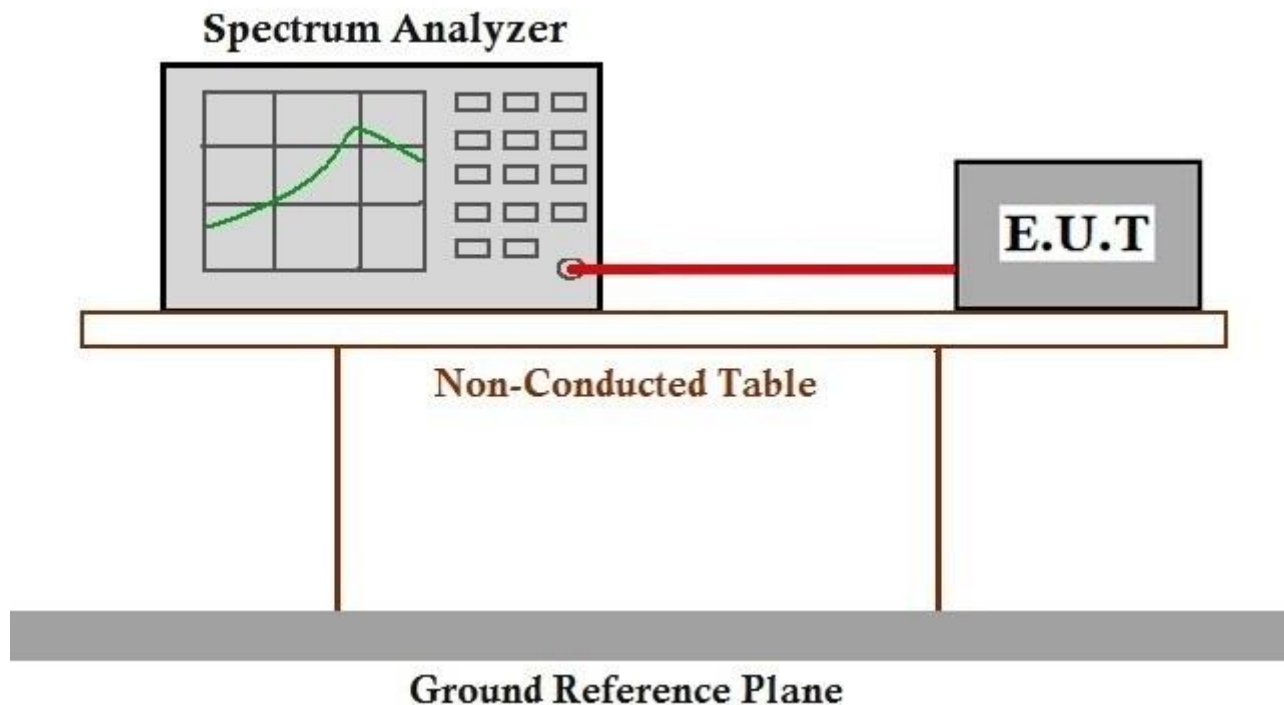

7.6.3 Measurement Procedure and Data

The detailed test data see: Appendix A SHEM180600476401



7.7 Conducted Band Edges Measurement

Test Requirement	47 CFR Part 15, Subpart C 15.247(d)
Test Method:	ANSI C63.10 (2013) Section 7.8.6
Limit:	In any 100 kHz bandwidth outside the frequency band in which the spread spectrum or digitally modulated intentional radiator is operating, the radio frequency power that is produced by the intentional radiator shall be at least 20 dB below that in the 100 kHz bandwidth within the band that contains the highest level of the desired power, based on either an RF conducted or a radiated measurement, provided the transmitter demonstrates compliance with the peak conducted power limits. If the transmitter complies with the conducted power limits based on the use of RMS averaging over a time interval, as permitted under paragraph (b)(3) of this section, the attenuation required under this paragraph shall be 30 dB instead of 20 dB. Attenuation below the general limits specified in §15.209(a) is not required. In addition, radiated emissions which fall in the restricted bands, as defined in §15.205(a), must also comply with the radiated emission limits specified in §15.209(a) (see §15.205(c))

7.7.1 E.U.T. Operation

Operating Environment:

Temperature: 22 °C Humidity: 50 % RH Atmospheric Pressure: 1002 mbar

Pretest these mode to find the worst case: a:TX_Hop mode_Keep the EUT in frequency hopping mode with GFSK modulation, $\pi/4$ DQPSK modulation, 8DPSK modulation. All modes have been tested and only the data of worst case is recorded in the report.

b:TX_non-Hop mode_Keep the EUT in continuously transmitting mode with GFSK modulation, $\pi/4$ DQPSK modulation, 8DPSK modulation. All modes have been tested and only the data of worst case is recorded in the report.

The worst case for final test: a:TX_Hop mode_Keep the EUT in frequency hopping mode with GFSK modulation, $\pi/4$ DQPSK modulation, 8DPSK modulation. All modes have been tested and only the data of worst case is recorded in the report.

7.7.2 Test Setup Diagram

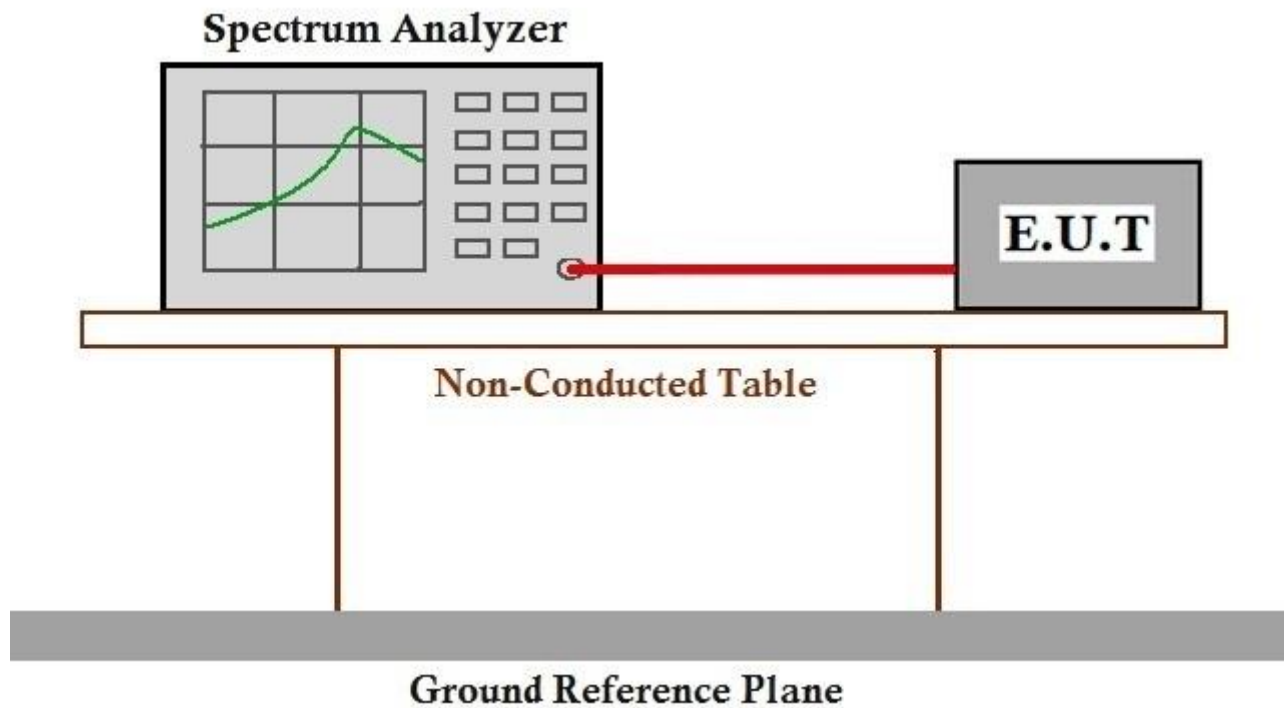

7.7.3 Measurement Procedure and Data

The detailed test data see: Appendix A SHEM180600476401

7.8 Conducted Spurious Emissions

Test Requirement 47 CFR Part 15, Subpart C 15.247(d)
Test Method: ANSI C63.10 (2013) Section 7.8.8
Limit: In any 100 kHz bandwidth outside the frequency band in which the spread spectrum or digitally modulated intentional radiator is operating, the radio frequency power that is produced by the intentional radiator shall be at least 20 dB below that in the 100 kHz bandwidth within the band that contains the highest level of the desired power, based on either an RF conducted or a radiated measurement, provided the transmitter demonstrates compliance with the peak conducted power limits. If the transmitter complies with the conducted power limits based on the use of RMS averaging over a time interval, as permitted under paragraph (b)(3) of this section, the attenuation required under this paragraph shall be 30 dB instead of 20 dB. Attenuation below the general limits specified in §15.209(a) is not required. In addition, radiated emissions which fall in the restricted bands, as defined in §15.205(a), must also comply with the radiated emission limits specified in §15.209(a) (see §15.205(c))

7.8.1 E.U.T. Operation

Operating Environment:
Temperature: 22 °C **Humidity:** 50 % RH **Atmospheric Pressure:** 1002 mbar
Test mode b:TX_non-Hop mode_Keep the EUT in continuously transmitting mode with GFSK modulation, $\pi/4$ DQPSK modulation, 8DPSK modulation. All modes have been tested and only the data of worst case is recorded in the report.

7.8.2 Test Setup Diagram

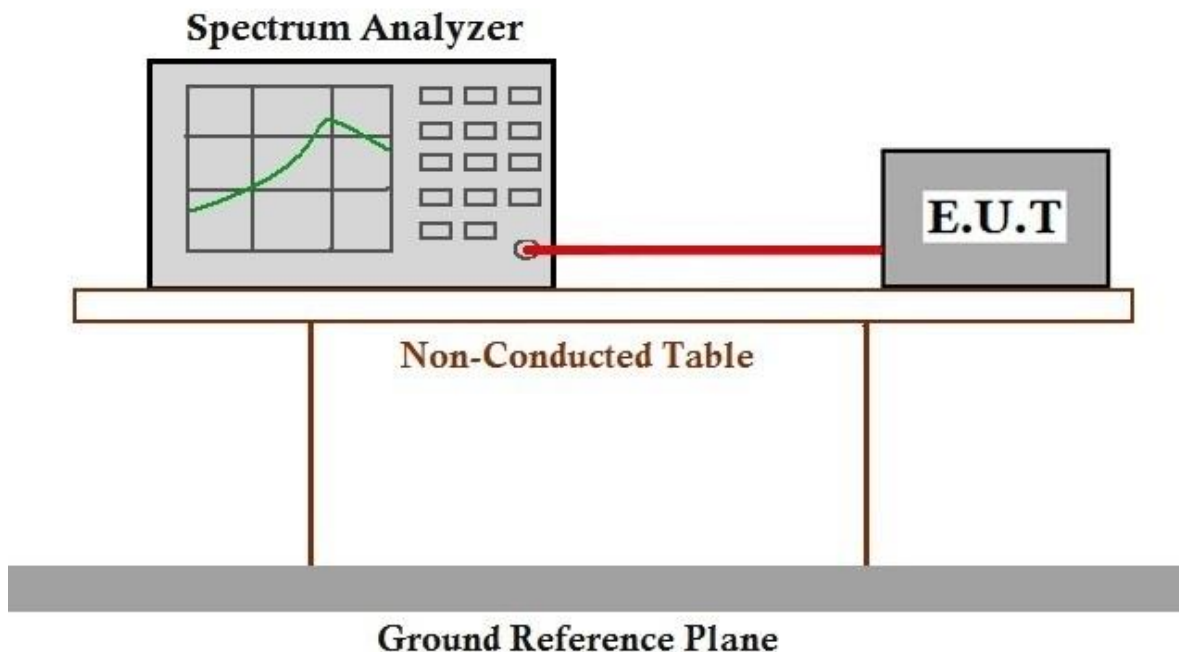

7.8.3 Measurement Procedure and Data

The detailed test data see: Appendix A SHEM180600476401



7.9 Radiated Emissions which fall in the restricted bands

Test Requirement 47 CFR Part 15, Subpart C 15.205 & 15.209

Test Method: ANSI C63.10 (2013) Section 6.10.5

Limit:

Frequency(MHz)	Field strength(microvolts/meter)	Measurement distance(meters)
0.009-0.490	2400/F(kHz)	300
0.490-1.705	24000/F(kHz)	30
1.705-30.0	30	30
30-88	100	3
88-216	150	3
216-960	200	3
Above 960	500	3

Remark: The emission limits shown in the above table are based on measurements employing a CISPR quasi-peak detector except for the frequency bands 9-90kHz, 110-490kHz and above 1000 MHz. Radiated emission limits in these three bands are based on measurements employing an average detector, the peak field strength of any emission shall not exceed the maximum permitted average limits specified above by more than 20 dB under any condition of modulation.

7.9.1 E.U.T. Operation

Operating Environment:

Temperature: 22 °C Humidity: 50 % RH Atmospheric Pressure: 1002 mbar

Test mode b:TX_non-Hop mode_Keep the EUT in continuously transmitting mode with GFSK modulation, $\pi/4$ DQPSK modulation, 8DPSK modulation. All modes have been tested and only the data of worst case is recorded in the report.

7.9.2 Test Setup Diagram

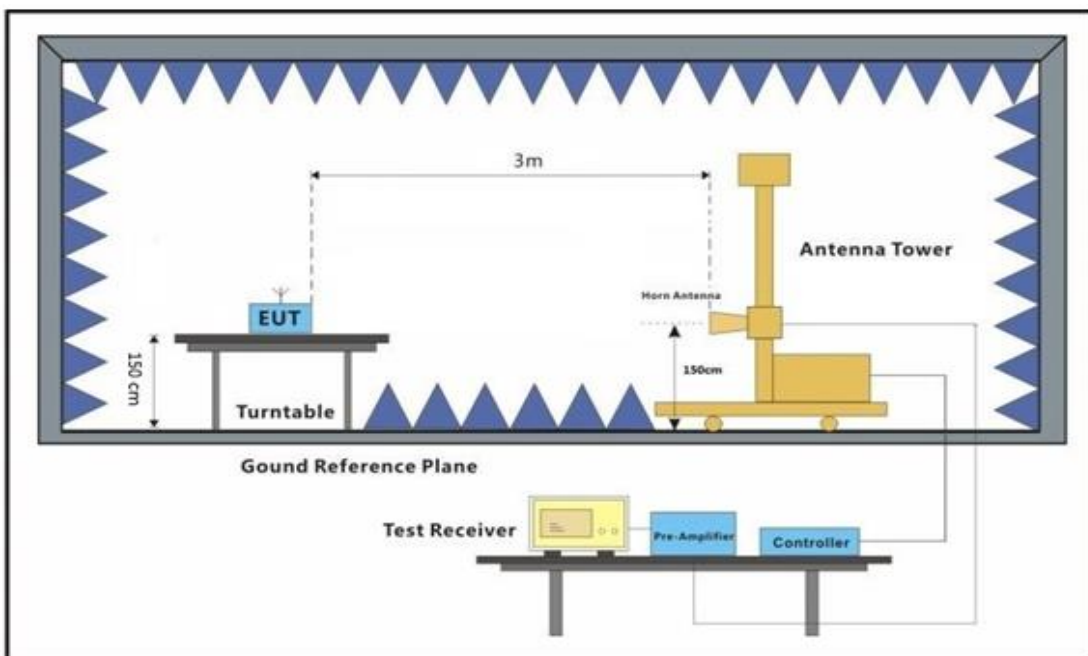
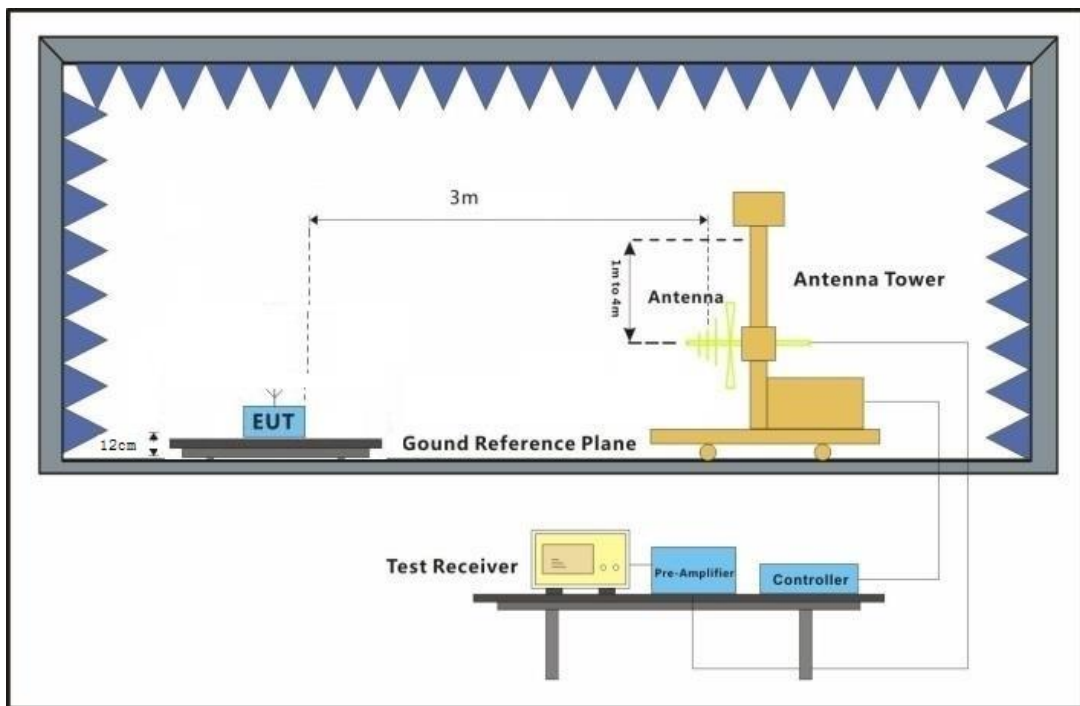
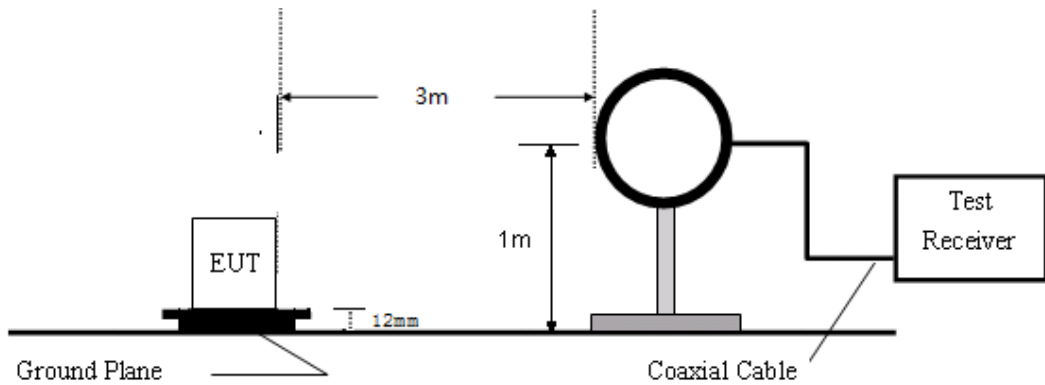



7.9.3 Measurement Procedure and Data

- a. For below 1GHz, the EUT was placed on the top of a rotating table 0.8 meters above the ground at a 3 or 10 meter semi-anechoic chamber. The table was rotated 360 degrees to determine the position of the highest radiation.
- b. For above 1GHz, the EUT was placed on the top of a rotating table 1.5 meters above the ground at a 3 meter fully-anechoic chamber. The table was rotated 360 degrees to determine the position of the highest radiation.
- c. The EUT was set 3 or 10 meters away from the interference-receiving antenna, which was mounted on the top of a variable-height antenna tower.
- d. The antenna height is varied from one meter to four meters above the ground to determine the maximum value of the field strength. Both horizontal and vertical polarizations of the antenna are set to make the measurement.
- e. For each suspected emission, the EUT was arranged to its worst case and then the antenna was tuned to heights from 1 meter to 4 meters (for the test frequency of below 30MHz, the antenna was tuned to heights 1 meter) and the rotatable table was turned from 0 degrees to 360 degrees to find the maximum reading.
- f. The test-receiver system was set to Peak Detect Function and Specified Bandwidth with Maximum Hold Mode.
- g. If the emission level of the EUT in peak mode was 10dB lower than the limit specified, then testing could be stopped and the peak values of the EUT would be reported. Otherwise the emissions that did not have 10dB margin would be re-tested one by one using peak, quasi-peak or average method as specified and then reported in a data sheet.
- h. Test the EUT in the lowest channel, the middle channel, the Highest channel.
- i. The radiation measurements are performed in X, Y, Z axis positioning for Transmitting mode, and found the X axis positioning which it is the worst case.
- j. Repeat above procedures until all frequencies measured was complete.

Remark 1: $Level = Read\ Level + Cable\ Loss + Antenna\ Factor - Preamp\ Factor$

Remark 2: For frequencies above 1GHz, the field strength limits are based on average limits. However, the peak field strength of any emission shall not exceed the maximum permitted average limits specified above by more than 20 dB under any condition of modulation. For the emissions whose peak level is lower than the average limit, only the peak measurement is shown in the report.



Mode:b; Polarization:Horizontal; Modulation:GFSK; ; Channel:Low

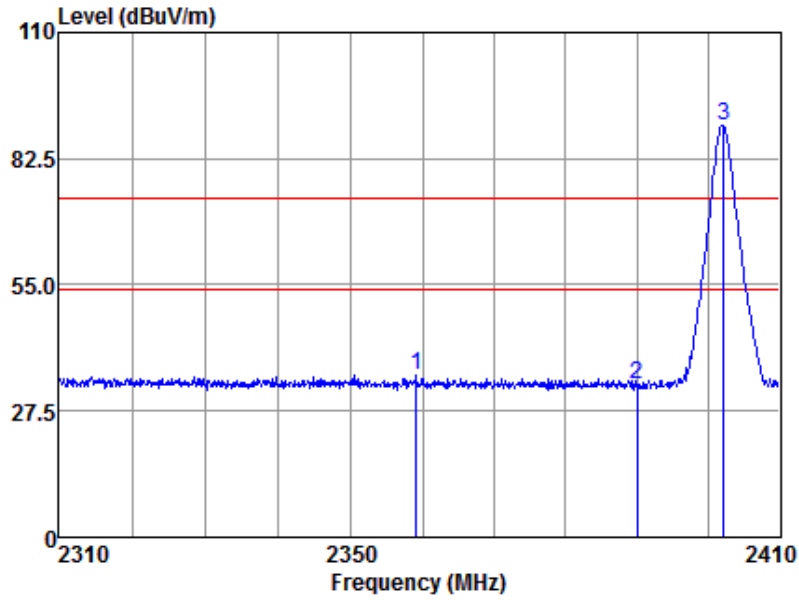

Antenna Polarity :HORIZONTAL

Freq	Read Level	Antenna Factor	Cable Loss	Preamp Factor	Emission Level	Limit Line	Over Limit	Remark
MHz	dBuv	dB/m	dB	dB	dBuv/m	dBuv/m	dB	
2359.17	40.37	25.99	6.42	37.36	35.42	74.00	-38.58	Peak
2390.00	38.31	26.03	6.47	37.36	33.45	74.00	-40.55	Peak
2402.25	94.55	26.05	6.50	37.35	89.75	74.00	15.75	Peak

Note:Emission Level=Read Level+Antenna Factor+Cable loss-Preamp Factor

Mode:b; Polarization:Vertical; Modulation:GFSK; ; Channel:Low

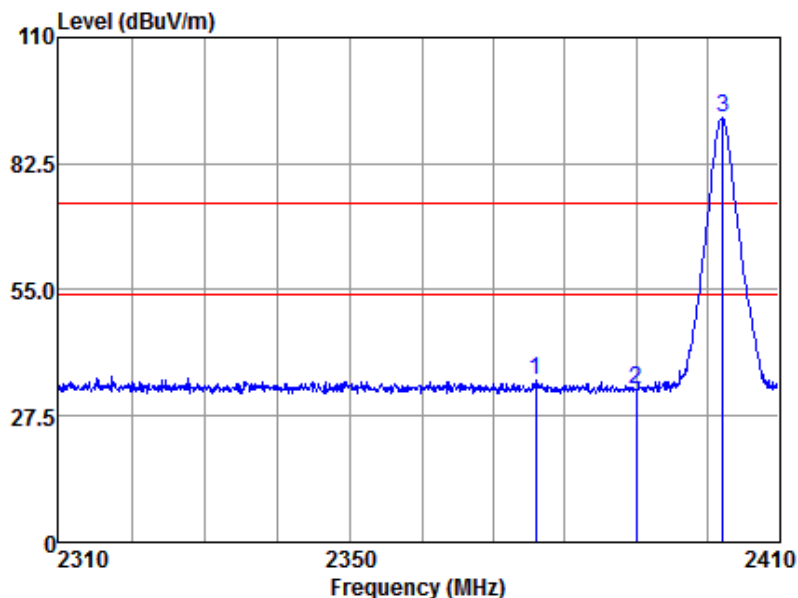

Antenna Polarity :VERTICAL

Freq	Read Level	Antenna Factor	Cable Loss	Preamplifier Factor	Emission Level	Limit Line	Over Limit	Remark
MHz	dBuv	dB/m	dB	dB	dBuv/m	dBuv/m	dB	
2375.93	40.39	26.01	6.45	37.36	35.49	74.00	-38.51	Peak
2390.00	38.32	26.03	6.47	37.36	33.46	74.00	-40.54	Peak
2402.25	97.14	26.05	6.50	37.35	92.34	74.00	18.34	Peak

Note:Emission Level=Read Level+Antenna Factor+Cable loss-Preamplifier Factor



Mode:b; Polarization:Horizontal; Modulation:GFSK; ; Channel:High

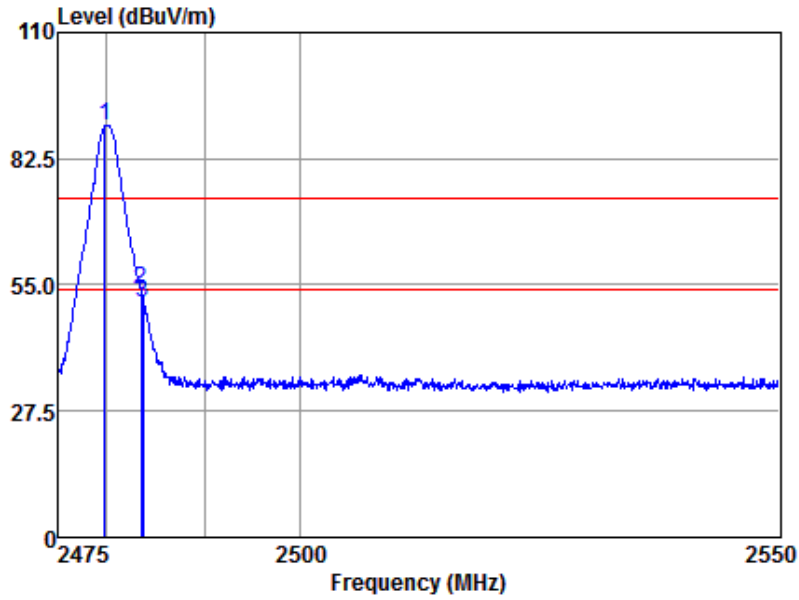

Antenna Polarity :HORIZONTAL

Freq	Read Level	Antenna Factor	Cable Loss	Preamp Factor	Emission Level	Limit Line	Over Limit	Remark
MHz	dBuV	dB/m	dB	dB	dBuV/m	dBuV/m	dB	
2479.81	94.17	26.17	6.74	37.49	89.59	74.00	15.59	Peak
2483.50	58.55	26.18	6.80	37.51	54.02	74.00	-19.98	Peak
2483.73	55.84	26.18	6.80	37.51	51.31	74.00	-22.69	Peak

Note:Emission Level=Read Level+Antenna Factor+Cable loss-Preamp Factor



Mode:b; Polarization:Horizontal; Modulation:GFSK; ; Channel:High

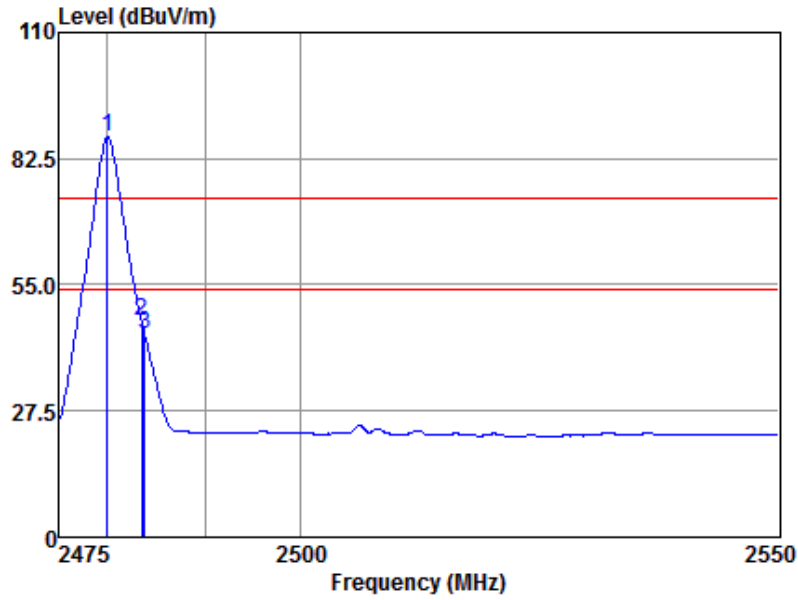

Antenna Polarity :HORIZONTAL

Freq	Read Level	Antenna Factor	Cable Loss	Preamp Factor	Emission Level	Limit Line	Over Limit	Remark
MHz	dBuv	dB/m	dB	dB	dBuv/m	dBuv/m	dB	
2479.96	91.68	26.17	6.74	37.49	87.10	54.00	33.10	Average
2483.50	51.62	26.18	6.80	37.51	47.09	54.00	-6.91	Average
2483.81	48.68	26.18	6.80	37.51	44.15	54.00	-9.85	Average

Note:Emission Level=Read Level+Antenna Factor+Cable loss-Preamp Factor



Mode:b; Polarization:Vertical; Modulation:GFSK; ; Channel:High

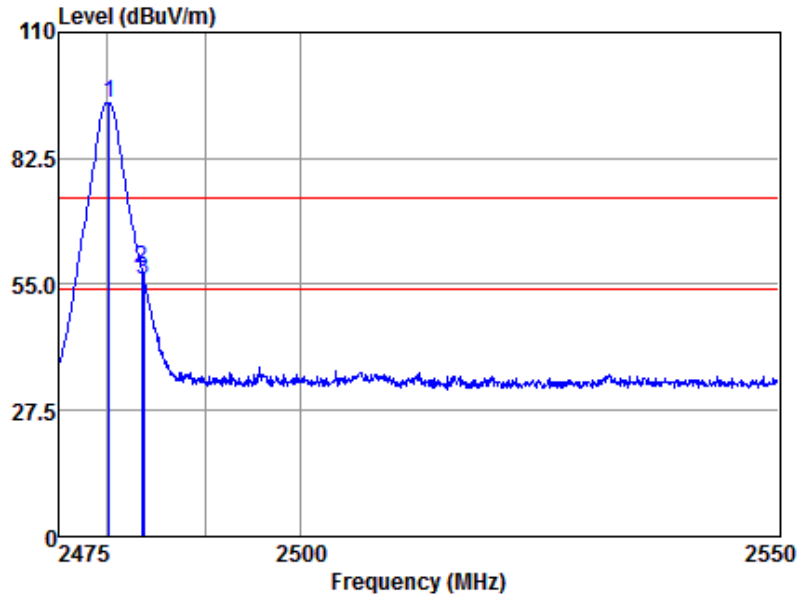

Antenna Polarity :VERTICAL

Freq	Read Level	Antenna Factor	Cable Loss	Preamp Factor	Emission Level	Limit Line	Over Limit	Remark
MHz	dBuv	dB/m	dB	dB	dBuv/m	dBuv/m	dB	
2480.10	99.11	26.17	6.74	37.49	94.53	74.00	20.53	Peak
2483.50	62.91	26.18	6.80	37.51	58.38	74.00	-15.62	Peak
2483.73	60.53	26.18	6.80	37.51	56.00	74.00	-18.00	Peak

Note:Emission Level=Read Level+Antenna Factor+Cable loss-Preamp Factor

Mode:b; Polarization:Vertical; Modulation:GFSK; ; Channel:High

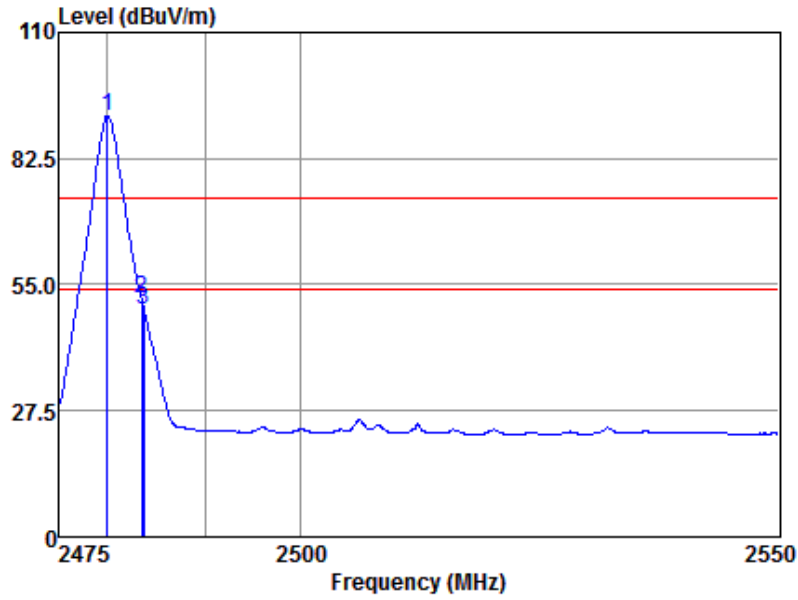

Antenna Polarity :VERTICAL

Freq	Read Level	Antenna Factor	Cable Loss	Preamp Factor	Emission Level	Limit Line	Over Limit	Remark
MHz	dBuv	dB/m	dB	dB	dBuv/m	dBuv/m	dB	
2479.96	96.50	26.17	6.74	37.49	91.92	54.00	37.92	Average
2483.50	56.35	26.18	6.80	37.51	51.82	54.00	-2.18	Average
2483.73	54.11	26.18	6.80	37.51	49.58	54.00	-4.42	Average

Note:Emission Level=Read Level+Antenna Factor+Cable loss-Preamp Factor

Mode:b; Polarization:Horizontal; Modulation: $\pi/4$ DQPSK; ; Channel:Low

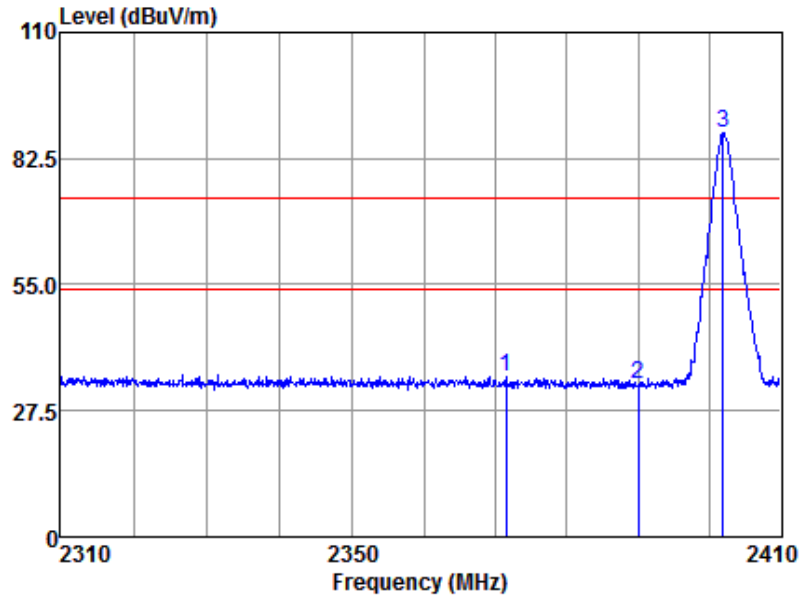

Antenna Polarity :HORIZONTAL

Freq	Read Level	Antenna Factor	Cable Loss	Preamp Factor	Emission Level	Limit Line	Over Limit	Remark
MHz	dBuv	dB/m	dB	dB	dBuv/m	dBuv/m	dB	
2371.50	39.75	26.01	6.45	37.36	34.85	74.00	-39.15	Peak
2390.00	38.26	26.03	6.47	37.36	33.40	74.00	-40.60	Peak
2401.95	92.97	26.05	6.50	37.35	88.17	74.00	14.17	Peak

Note:Emission Level=Read Level+Antenna Factor+Cable loss-Preamp Factor

Mode:b; Polarization:Vertical; Modulation: $\pi/4$ DQPSK; ; Channel:Low

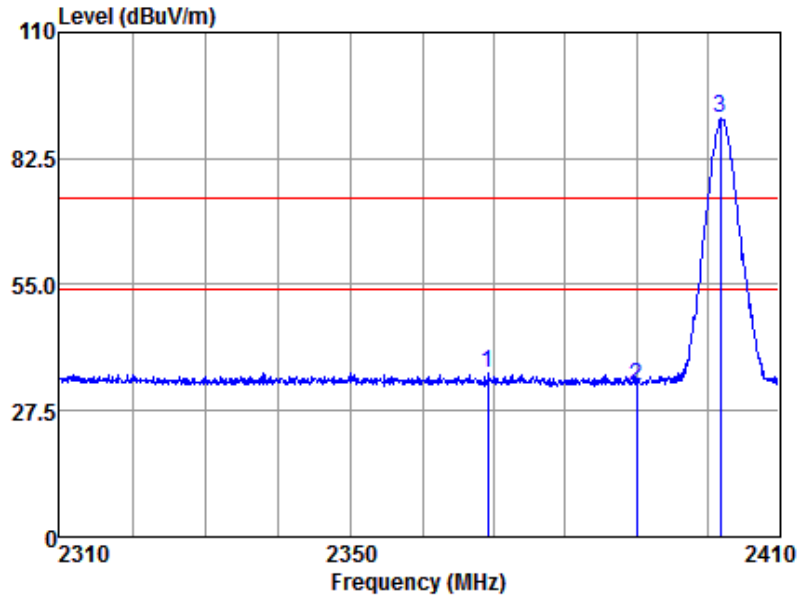

Antenna Polarity :VERTICAL

Freq	Read Level	Antenna Factor	Cable Loss	Preamp Factor	Emission Level	Limit Line	Over Limit	Remark
MHz	dBuv	dB/m	dB	dB	dBuv/m	dBuv/m	dB	
2369.19	40.73	26.00	6.45	37.36	35.82	74.00	-38.18	Peak
2390.00	37.93	26.03	6.47	37.36	33.07	74.00	-40.93	Peak
2401.84	95.96	26.05	6.50	37.35	91.16	74.00	17.16	Peak

Note:Emission Level=Read Level+Antenna Factor+Cable loss-Preamp Factor

Mode:b; Polarization:Horizontal; Modulation: $\pi/4$ DQPSK; ; Channel:High

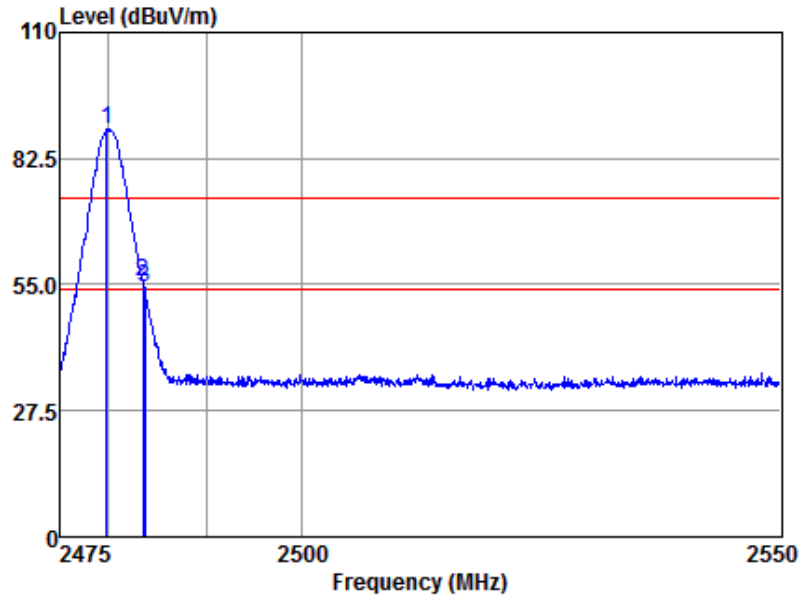

Antenna Polarity :HORIZONTAL

Freq	Read Level	Antenna Factor	Cable Loss	Preamp Factor	Emission Level	Limit Line	Over Limit	Remark
MHz	dBuv	dB/m	dB	dB	dBuv/m	dBuv/m	dB	
2479.81	93.31	26.17	6.74	37.49	88.73	74.00	14.73	Peak
2483.50	60.26	26.18	6.80	37.51	55.73	74.00	-18.27	Peak
2483.66	58.76	26.18	6.80	37.51	54.23	74.00	-19.77	Peak

Note:Emission Level=Read Level+Antenna Factor+Cable loss-Preamp Factor

Mode:b; Polarization:Horizontal; Modulation: $\pi/4$ DQPSK; ; Channel:High

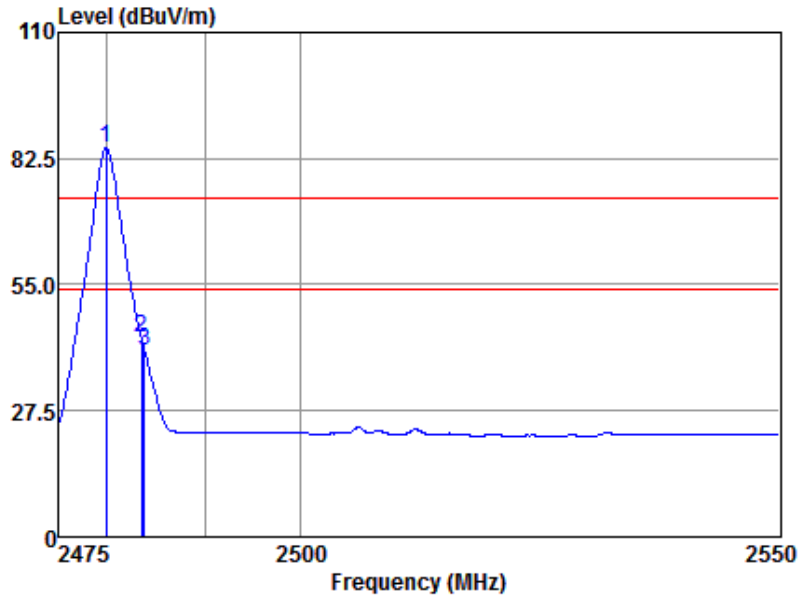

Antenna Polarity :HORIZONTAL

Freq	Read Level	Antenna Factor	Cable Loss	Preamp Factor	Emission Level	Limit Line	Over Limit	Remark
MHz	dBuv	dB/m	dB	dB	dBuv/m	dBuv/m	dB	
2479.88	89.37	26.17	6.74	37.49	84.79	54.00	30.79	Average
2483.50	48.10	26.18	6.80	37.51	43.57	54.00	-10.43	Average
2483.81	45.29	26.18	6.80	37.51	40.76	54.00	-13.24	Average

Note:Emission Level=Read Level+Antenna Factor+Cable loss-Preamp Factor



Mode:b; Polarization:Vertical; Modulation: $\pi/4$ DQPSK; ; Channel:High

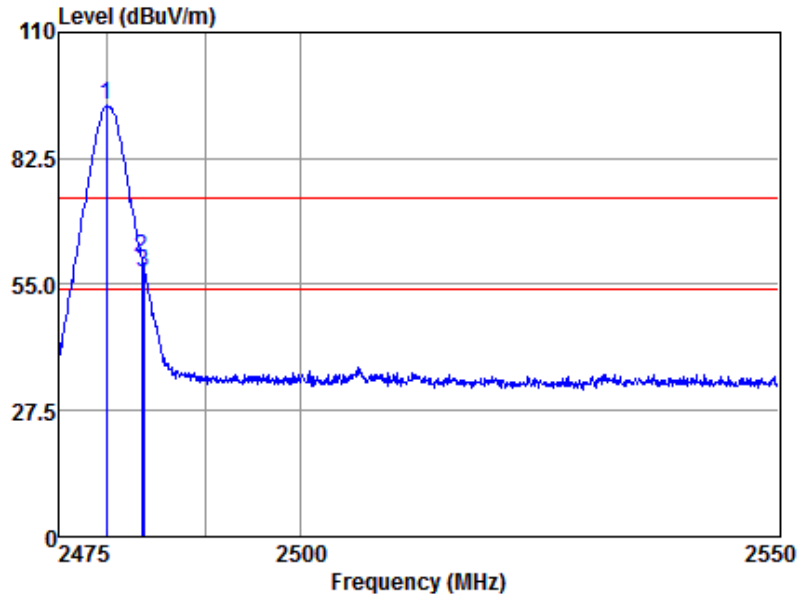

Antenna Polarity :VERTICAL

Freq	Read Level	Antenna Factor	Cable Loss	Preamp Factor	Emission Level	Limit Line	Over Limit	Remark
MHz	dBuv	dB/m	dB	dB	dBuv/m	dBuv/m	dB	
2479.88	98.58	26.17	6.74	37.49	94.00	74.00	20.00	Peak
2483.50	65.34	26.18	6.80	37.51	60.81	74.00	-13.19	Peak
2483.73	62.15	26.18	6.80	37.51	57.62	74.00	-16.38	Peak

Note:Emission Level=Read Level+Antenna Factor+Cable loss-Preamp Factor

Mode:b; Polarization:Vertical; Modulation: $\pi/4$ DQPSK; ; Channel:High

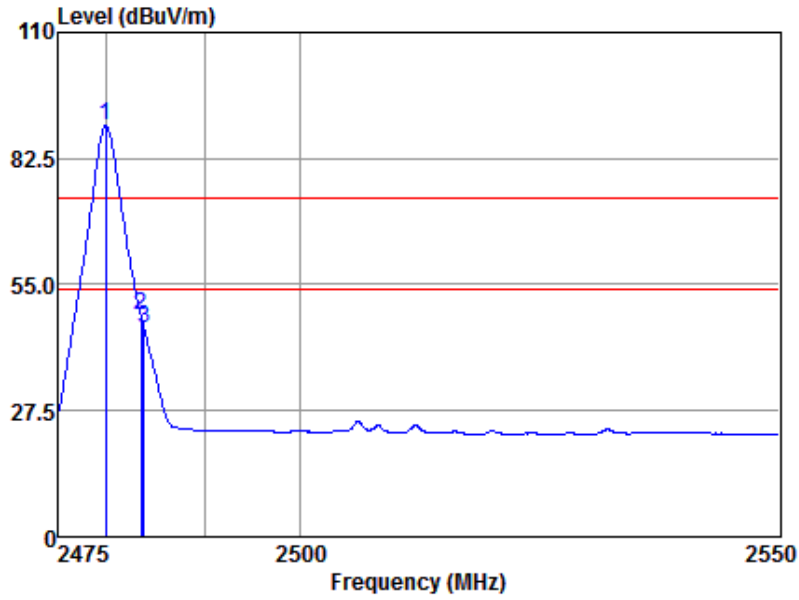

Antenna Polarity :VERTICAL

Freq	Read Level	Antenna Factor	Cable Loss	Preamp Factor	Emission Level	Limit Line	Over Limit	Remark
MHz	dBuV	dB/m	dB	dB	dBuV/m	dBuV/m	dB	
2479.88	94.32	26.17	6.74	37.49	89.74	54.00	35.74	Average
2483.50	52.92	26.18	6.80	37.51	48.39	54.00	-5.61	Average
2483.81	50.10	26.18	6.80	37.51	45.57	54.00	-8.43	Average

Note:Emission Level=Read Level+Antenna Factor+Cable loss-Preamp Factor



Mode:b; Polarization:Horizontal; Modulation:8DPSK; ; Channel:Low

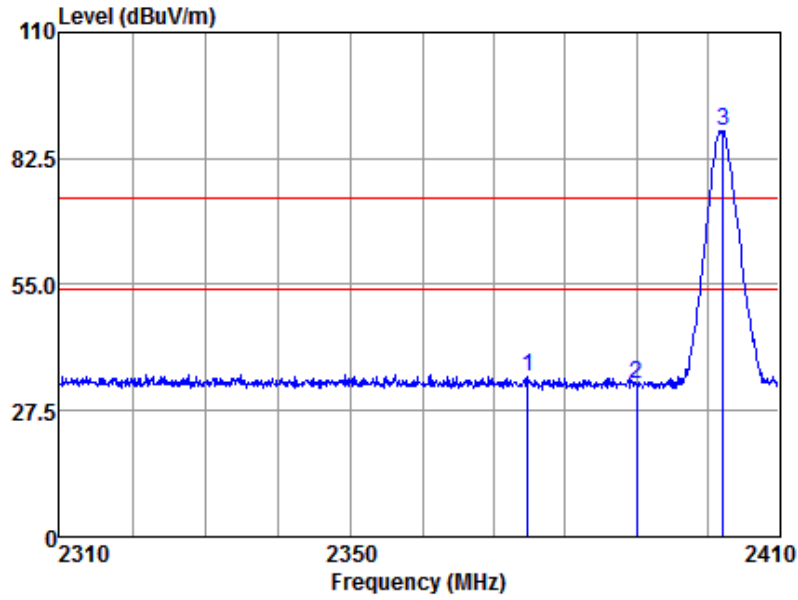

Antenna Polarity :HORIZONTAL

Freq	Read Level	Antenna Factor	Cable Loss	Preamp Factor	Emission Level	Limit Line	Over Limit	Remark
MHz	dBuv	dB/m	dB	dB	dBuv/m	dBuv/m	dB	
2374.72	39.94	26.01	6.45	37.36	35.04	74.00	-38.96	Peak
2390.00	38.18	26.03	6.47	37.36	33.32	74.00	-40.68	Peak
2402.25	93.26	26.05	6.50	37.35	88.46	74.00	14.46	Peak

Note:Emission Level=Read Level+Antenna Factor+Cable loss-Preamp Factor



Mode:b; Polarization:Vertical; Modulation:8DPSK; ; Channel:Low

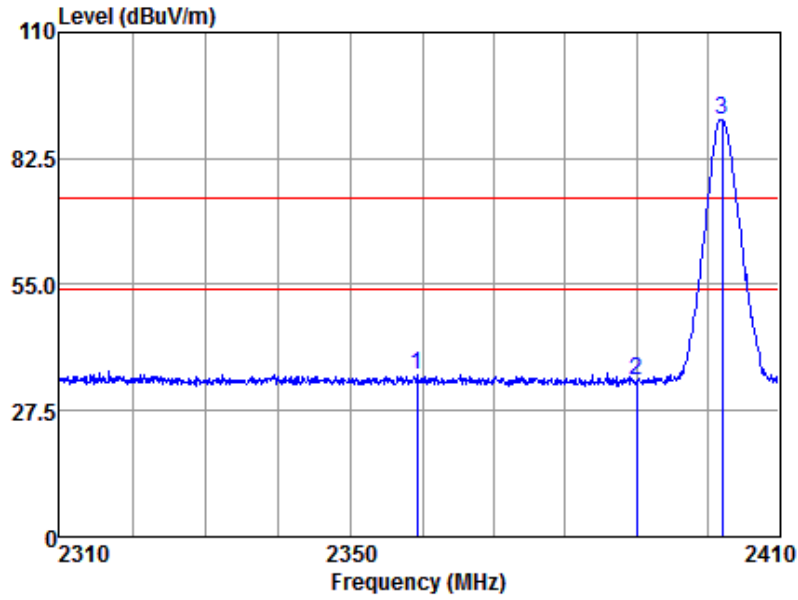

Antenna Polarity :VERTICAL

Freq	Read Level	Antenna Factor	Cable Loss	Preamp Factor	Emission Level	Limit Line	Over Limit	Remark
MHz	dBuv	dB/m	dB	dB	dBuv/m	dBuv/m	dB	
2359.27	40.21	25.99	6.42	37.36	35.26	74.00	-38.74	Peak
2390.00	39.05	26.03	6.47	37.36	34.19	74.00	-39.81	Peak
2402.15	95.84	26.05	6.50	37.35	91.04	74.00	17.04	Peak

Note:Emission Level=Read Level+Antenna Factor+Cable loss-Preamp Factor

Mode:b; Polarization:Horizontal; Modulation:8DPSK; ; Channel:High

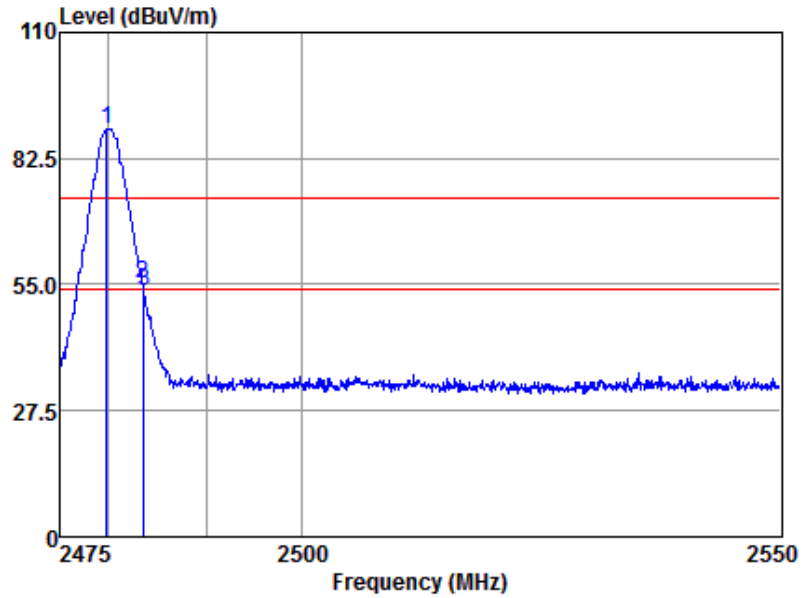

Antenna Polarity :HORIZONTAL

Freq	Read Level	Antenna Factor	Cable Loss	Preamp Factor	Emission Level	Limit Line	Over Limit	Remark
MHz	dBuv	dB/m	dB	dB	dBuv/m	dBuv/m	dB	
2479.81	93.50	26.17	6.74	37.49	88.92	74.00	14.92	Peak
2483.50	59.87	26.18	6.80	37.51	55.34	74.00	-18.66	Peak
2483.59	58.07	26.18	6.80	37.51	53.54	74.00	-20.46	Peak

Note:Emission Level=Read Level+Antenna Factor+Cable loss-Preamp Factor

Mode:b; Polarization:Horizontal; Modulation:8DPSK; ; Channel:High

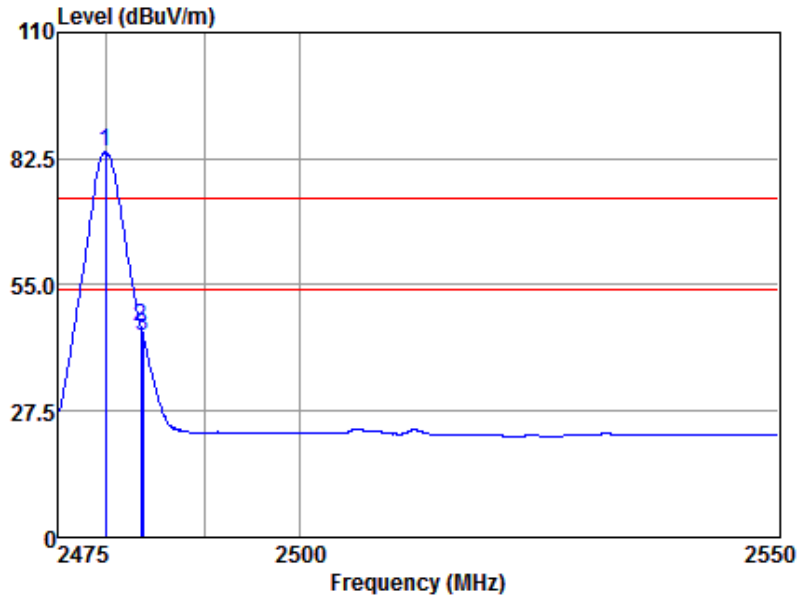

Antenna Polarity :HORIZONTAL

Freq	Read Level	Antenna Factor	Cable Loss	Preamp Factor	Emission Level	Limit Line	Over Limit	Remark
MHz	dBuV	dB/m	dB	dB	dBuV/m	dBuV/m	dB	
2479.88	88.41	26.17	6.74	37.49	83.83	54.00	29.83	Average
2483.50	50.56	26.18	6.80	37.51	46.03	54.00	-7.97	Average
2483.73	48.33	26.18	6.80	37.51	43.80	54.00	-10.20	Average

Note:Emission Level=Read Level+Antenna Factor+Cable loss-Preamp Factor

Mode:b; Polarization:Vertical; Modulation:8DPSK; ; Channel:High

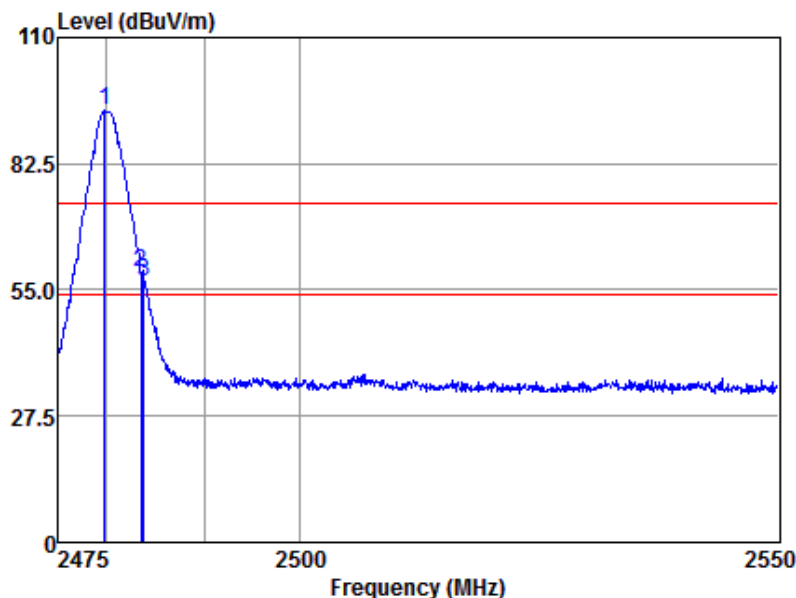

Antenna Polarity :VERTICAL

Freq	Read Level	Antenna Factor	Cable Loss	Preamp Factor	Emission Level	Limit Line	Over Limit	Remark
MHz	dBuv	dB/m	dB	dB	dBuv/m	dBuv/m	dB	
2479.81	98.60	26.17	6.74	37.49	94.02	74.00	20.02	Peak
2483.50	63.56	26.18	6.80	37.51	59.03	74.00	-14.97	Peak
2483.81	61.51	26.18	6.80	37.51	56.98	74.00	-17.02	Peak

Note:Emission Level=Read Level+Antenna Factor+Cable loss-Preamp Factor



Mode:b; Polarization:Vertical; Modulation:8DPSK; ; Channel:High

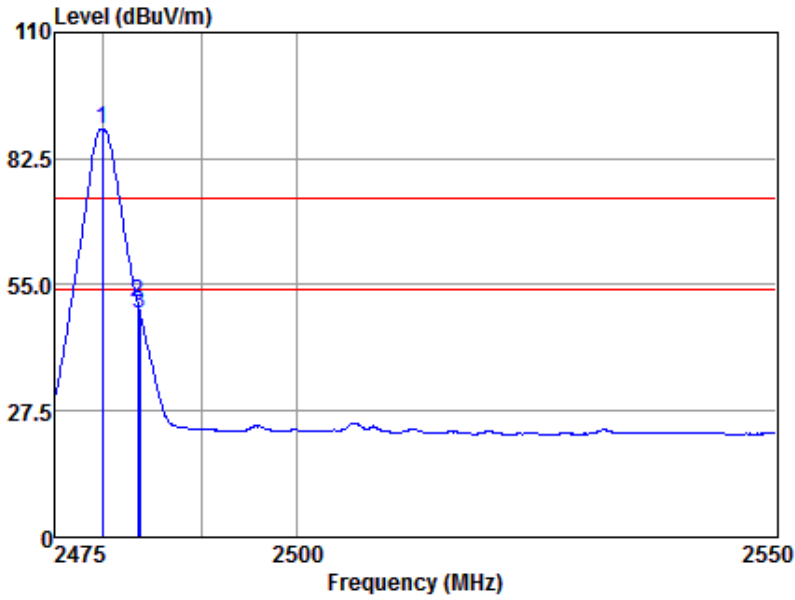

Antenna Polarity :VERTICAL

Freq	Read Level	Antenna Factor	Cable Loss	Preamp Factor	Emission Level	Limit Line	Over Limit	Remark
MHz	dBuv	dB/m	dB	dB	dBuv/m	dBuv/m	dB	
2479.88	93.65	26.17	6.74	37.49	89.07	54.00	35.07	Average
2483.50	55.67	26.18	6.80	37.51	51.14	54.00	-2.86	Average
2483.73	53.37	26.18	6.80	37.51	48.84	54.00	-5.16	Average

Note:Emission Level=Read Level+Antenna Factor+Cable loss-Preamp Factor



7.10 Radiated Spurious Emissions

Test Requirement 47 CFR Part 15, Subpart C 15.205 & 15.209

Test Method: ANSI C63.10 (2013) Section 6.4,6.5,6.6

Limit:

Frequency(MHz)	Field strength(microvolts/meter)	Measurement distance(meters)
0.009-0.490	2400/F(kHz)	300
0.490-1.705	24000/F(kHz)	30
1.705-30.0	30	30
30-88	100	3
88-216	150	3
216-960	200	3
Above 960	500	3

Remark: The emission limits shown in the above table are based on measurements employing a CISPR quasi-peak detector except for the frequency bands 9-90kHz, 110-490kHz and above 1000 MHz. Radiated emission limits in these three bands are based on measurements employing an average detector, the peak field strength of any emission shall not exceed the maximum permitted average limits specified above by more than 20 dB under any condition of modulation.



7.10.1 E.U.T. Operation

Operating Environment:

Temperature: 22 °C Humidity: 50 % RH Atmospheric Pressure: 1002 mbar

Test mode b:TX_non-Hop mode_Keep the EUT in continuously transmitting mode with GFSK modulation, $\pi/4$ DQPSK modulation, 8DPSK modulation. All modes have been tested and only the data of worst case is recorded in the report.

7.10.2 Test Setup Diagram

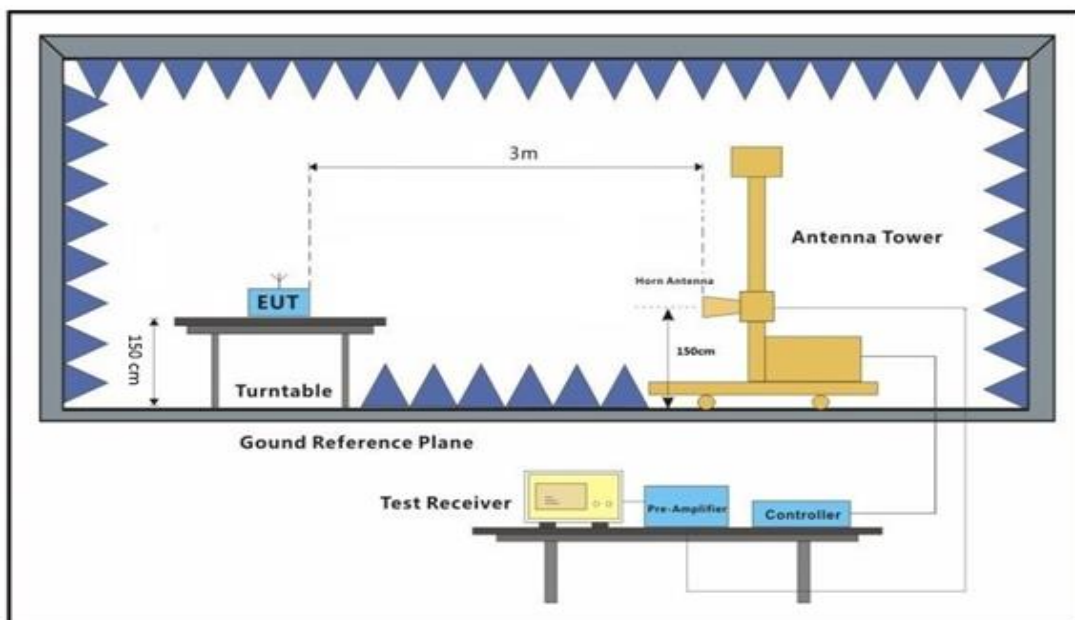
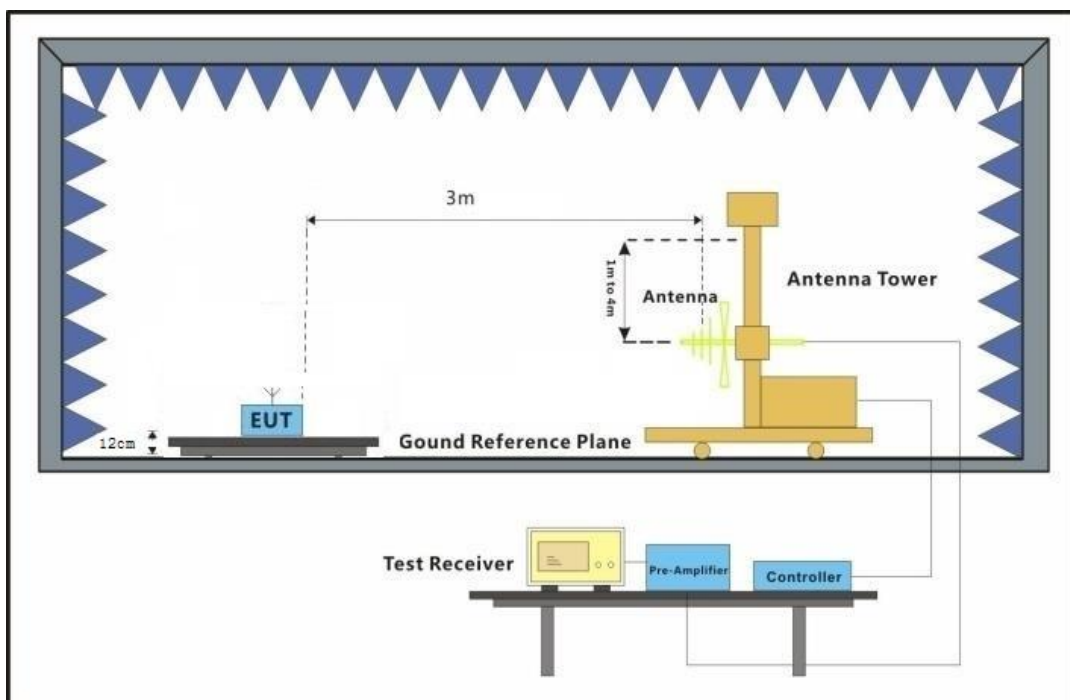
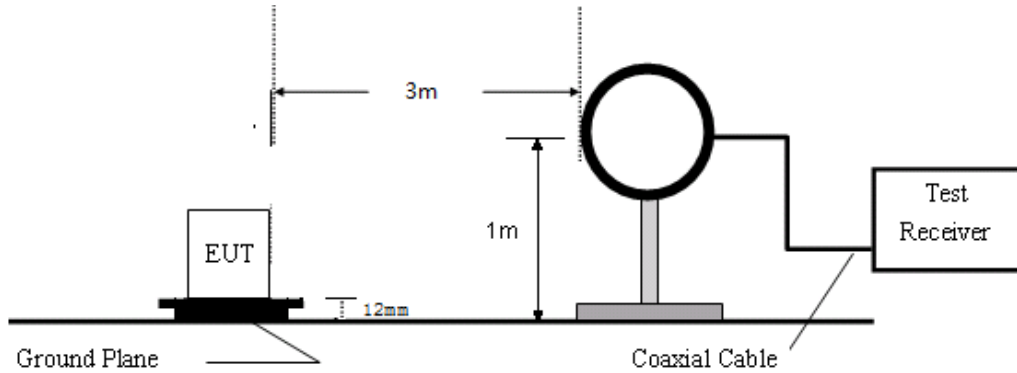

7.10.3 Measurement Procedure and Data

- a. For below 1GHz, the EUT was placed on the top of a rotating table 0.8 meters above the ground at a 3 or 10 meter semi-anechoic chamber. The table was rotated 360 degrees to determine the position of the highest radiation.
- b. For above 1GHz, the EUT was placed on the top of a rotating table 1.5 meters above the ground at a 3 meter fully-anechoic chamber. The table was rotated 360 degrees to determine the position of the highest radiation.
- c. The EUT was set 3 or 10 meters away from the interference-receiving antenna, which was mounted on the top of a variable-height antenna tower.
- d. The antenna height is varied from one meter to four meters above the ground to determine the maximum value of the field strength. Both horizontal and vertical polarizations of the antenna are set to make the measurement.
- e. For each suspected emission, the EUT was arranged to its worst case and then the antenna was tuned to heights from 1 meter to 4 meters (for the test frequency of below 30MHz, the antenna was tuned to heights 1 meter) and the rotatable table was turned from 0 degrees to 360 degrees to find the maximum reading.
- f. The test-receiver system was set to Peak Detect Function and Specified Bandwidth with Maximum Hold Mode.
- g. If the emission level of the EUT in peak mode was 10dB lower than the limit specified, then testing could be stopped and the peak values of the EUT would be reported. Otherwise the emissions that did not have 10dB margin would be re-tested one by one using peak, quasi-peak or average method as specified and then reported in a data sheet.
- h. Test the EUT in the lowest channel, the middle channel, the Highest channel.
- i. The radiation measurements are performed in X, Y, Z axis positioning for Transmitting mode, and found the X axis positioning which it is the worst case.
- j. Repeat above procedures until all frequencies measured was complete.

Remark:

- 1) For emission below 1GHz, through pre-scan found the worst case is the lowest channel. Only the worst case is recorded in the report.
- 2) The field strength is calculated by adding the Antenna Factor, Cable Factor & Pre-amplifier. The basic equation with a sample calculation is as follows:
Final Test Level = Receiver Reading + Antenna Factor + Cable Factor – Pre-amplifier Factor
- 3) Scan from 9kHz to 25GHz, the disturbance above 18GHz and below 30MHz was very low. The points marked on above plots are the highest emissions could be found when testing, so only above points had been displayed. The amplitude of spurious emissions from the radiator which are attenuated more than 20dB below the limit need not be reported.
- 4) For frequencies above 1GHz, the field strength limits are based on average limits. However, the peak field strength of any emission shall not exceed the maximum permitted average limits specified above by more than 20 dB under any condition of modulation. For the emissions whose peak level is lower than the average limit, only the peak measurement is shown



Mode:b; Polarization:Horizontal; Modulation:GFSK; ; Channel:Low

Frequency	RX_R	Factor	Emission	Limit	Over Limit	Detector
MHz	dBuV	dB	dBuV/m	dBuV/m	dB	
4804	37.77	6.18	43.95	54	-10.05	peak
7206	39.33	10.63	49.96	54	-4.04	peak
9608	32.66	14.38	47.04	54	-6.96	peak

Mode:b; Polarization:Vertical; Modulation:GFSK; ; Channel:Low

Frequency	RX_R	Factor	Emission	Limit	Over Limit	Detector
MHz	dBuV	dB	dBuV/m	dBuV/m	dB	
4804	32.25	6.18	38.43	54	-15.57	peak
7206	34.18	10.63	44.81	54	-9.19	peak
9608	34.08	14.38	48.46	54	-5.54	peak

Mode:b; Polarization:Horizontal; Modulation:GFSK; ; Channel:middle

Frequency	RX_R	Factor	Emission	Limit	Over Limit	Detector
MHz	dBuV	dB	dBuV/m	dBuV/m	dB	
4882	35.62	7.00	42.62	54	-11.38	peak
7323	36.70	11.13	47.83	54	-6.17	peak
9764	34.01	14.36	48.37	54	-5.63	peak

Mode:b; Polarization:Vertical; Modulation:GFSK; ; Channel:middle

Frequency	RX_R	Factor	Emission	Limit	Over Limit	Detector
MHz	dBuV	dB	dBuV/m	dBuV/m	dB	
4882	35.02	7.00	42.02	54	-11.98	peak
7323	34.52	11.13	45.65	54	-8.35	peak
9764	32.56	14.36	46.92	54	-7.08	peak

Mode:b; Polarization:Horizontal; Modulation:GFSK; ; Channel:High

Frequency	RX_R	Factor	Emission	Limit	Over Limit	Detector
MHz	dBuV	dB	dBuV/m	dBuV/m	dB	
4960	39.25	7.49	46.74	54	-7.26	peak
7440	35.87	11.65	47.52	54	-6.48	peak
9920	31.78	14.40	46.18	54	-7.82	peak

Mode:b; Polarization:Vertical; Modulation:GFSK; ; Channel:High

Frequency	RX_R	Factor	Emission	Limit	Over Limit	Detector
MHz	dBuV	dB	dBuV/m	dBuV/m	dB	
4960	35.74	7.49	43.23	54	-10.77	peak
7440	34.18	11.65	45.83	54	-8.17	peak
9920	33.62	14.40	48.02	54	-5.98	peak



Mode:b; Polarization:Horizontal; Modulation: $\pi/4$ DQPSK; ; Channel:Low

Frequency	RX_R	Factor	Emission	Limit	Over Limit	Detector
MHz	dBuV	dB	dBuV/m	dBuV/m	dB	
4804	36.73	6.18	42.91	54	-11.09	peak
7206	38.32	10.63	48.95	54	-5.05	peak
9608	34.29	14.38	48.67	54	-5.33	peak

Mode:b; Polarization:Vertical; Modulation: $\pi/4$ DQPSK; ; Channel:Low

Frequency	RX_R	Factor	Emission	Limit	Over Limit	Detector
MHz	dBuV	dB	dBuV/m	dBuV/m	dB	
4804	37.91	6.18	44.09	54	-9.91	peak
7206	37.70	10.63	48.33	54	-5.67	peak
9608	30.84	14.38	45.22	54	-8.78	peak

Mode:b; Polarization:Horizontal; Modulation: $\pi/4$ DQPSK; ; Channel:middle

Frequency	RX_R	Factor	Emission	Limit	Over Limit	Detector
MHz	dBuV	dB	dBuV/m	dBuV/m	dB	
4882	37.97	7.00	44.97	54	-9.03	peak
7323	38.08	11.13	49.21	54	-4.79	peak
9764	32.12	14.36	46.48	54	-7.52	peak

Mode:b; Polarization:Vertical; Modulation: $\pi/4$ DQPSK; ; Channel:middle

Frequency	RX_R	Factor	Emission	Limit	Over Limit	Detector
MHz	dBuV	dB	dBuV/m	dBuV/m	dB	
4882	38.38	7.00	45.38	54	-8.62	peak
7323	36.55	11.13	47.68	54	-6.32	peak
9764	31.58	14.36	45.94	54	-8.06	peak

Mode:b; Polarization:Horizontal; Modulation: $\pi/4$ DQPSK; ; Channel:High

Frequency	RX_R	Factor	Emission	Limit	Over Limit	Detector
MHz	dBuV	dB	dBuV/m	dBuV/m	dB	
4960	37.30	7.49	44.79	54	-9.21	peak
7440	36.06	11.65	47.71	54	-6.29	peak
9920	32.14	14.40	46.54	54	-7.46	peak

Mode:b; Polarization:Vertical; Modulation: $\pi/4$ DQPSK; ; Channel:High

Frequency	RX_R	Factor	Emission	Limit	Over Limit	Detector
MHz	dBuV	dB	dBuV/m	dBuV/m	dB	
4960	33.83	7.49	41.32	54	-12.68	peak
7440	35.47	11.65	47.12	54	-6.88	peak
9920	33.45	14.40	47.85	54	-6.15	peak



Mode:b; Polarization:Horizontal; Modulation:8DPSK; ; Channel:Low

Frequency	RX_R	Factor	Emission	Limit	Over Limit	Detector
MHz	dBuV	dB	dBuV/m	dBuV/m	dB	
4804	36.24	6.18	42.42	54	-11.58	peak
7206	34.59	10.63	45.22	54	-8.78	peak
9608	32.38	14.38	46.76	54	-7.24	peak

Mode:b; Polarization:Vertical; Modulation:8DPSK; ; Channel:Low

Frequency	RX_R	Factor	Emission	Limit	Over Limit	Detector
MHz	dBuV	dB	dBuV/m	dBuV/m	dB	
4804	35.19	6.18	41.37	54	-12.63	peak
7206	35.04	10.63	45.67	54	-8.33	peak
9608	33.15	14.38	47.53	54	-6.47	peak

Mode:b; Polarization:Horizontal; Modulation:8DPSK; ; Channel:middle

Frequency	RX_R	Factor	Emission	Limit	Over Limit	Detector
MHz	dBuV	dB	dBuV/m	dBuV/m	dB	
4882	39.14	7.00	46.14	54	-7.86	peak
7323	35.97	11.13	47.10	54	-6.90	peak
9764	34.37	14.36	48.73	54	-5.27	peak

Mode:b; Polarization:Vertical; Modulation:8DPSK; ; Channel:middle

Frequency	RX_R	Factor	Emission	Limit	Over Limit	Detector
MHz	dBuV	dB	dBuV/m	dBuV/m	dB	
4882	36.08	7.00	43.08	54	-10.92	peak
7323	38.34	11.13	49.47	54	-4.53	peak
9764	33.92	14.36	48.28	54	-5.72	peak

Mode:b; Polarization:Horizontal; Modulation:8DPSK; ; Channel:High

Frequency	RX_R	Factor	Emission	Limit	Over Limit	Detector
MHz	dBuV	dB	dBuV/m	dBuV/m	dB	
4960	38.29	7.49	45.78	54	-8.22	peak
7440	36.31	11.65	47.96	54	-6.04	peak
9920	32.93	14.40	47.33	54	-6.67	peak

Mode:b; Polarization:Vertical; Modulation:8DPSK; ; Channel:High

Frequency	RX_R	Factor	Emission	Limit	Over Limit	Detector
MHz	dBuV	dB	dBuV/m	dBuV/m	dB	
4960	39.47	7.49	46.96	54	-7.04	peak
7440	37.33	11.65	48.98	54	-5.02	peak
9920	33.52	14.40	47.92	54	-6.08	peak



8 Test Setup Photographs

Refer to the < Test Setup photos-FCC >.

9 EUT Constructional Details

Refer to the < External Photos > & < Internal Photos >.



Appendix A for SHEM180600476401

1.20 dB Bandwidth

Test Mode	Test Channel	EBW[MHz]	Limit[MHz]	Verdict
DH5	2402	1.04	---	PASS
DH5	2441	1.04	---	PASS
DH5	2480	1.04	---	PASS
2DH5	2402	1.16	---	PASS
2DH5	2441	1.16	---	PASS
2DH5	2480	1.16	---	PASS
3DH5	2402	1.17	---	PASS
3DH5	2441	1.17	---	PASS
3DH5	2480	1.17	---	PASS



20 dB Bandwidth_DH5_2402

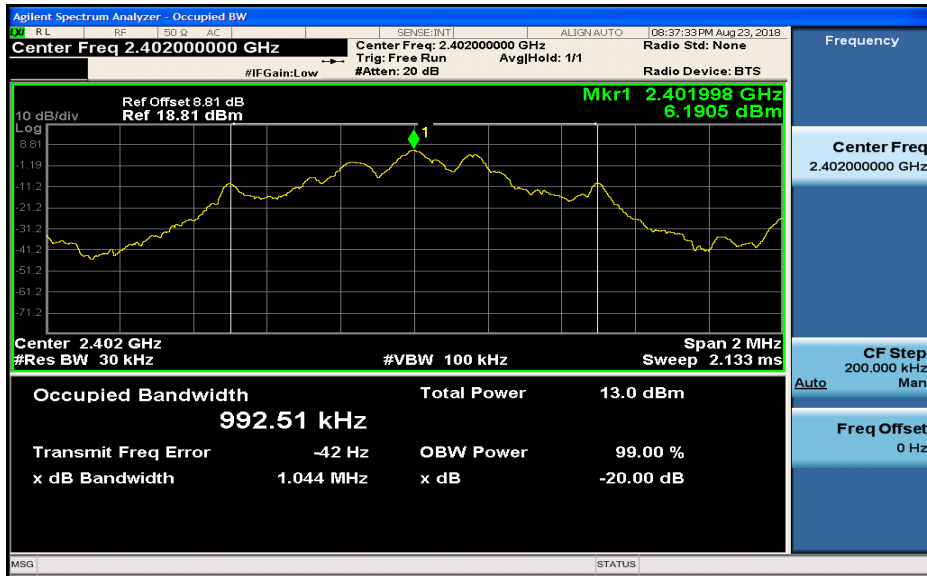

20 dB Bandwidth_DH5_2441

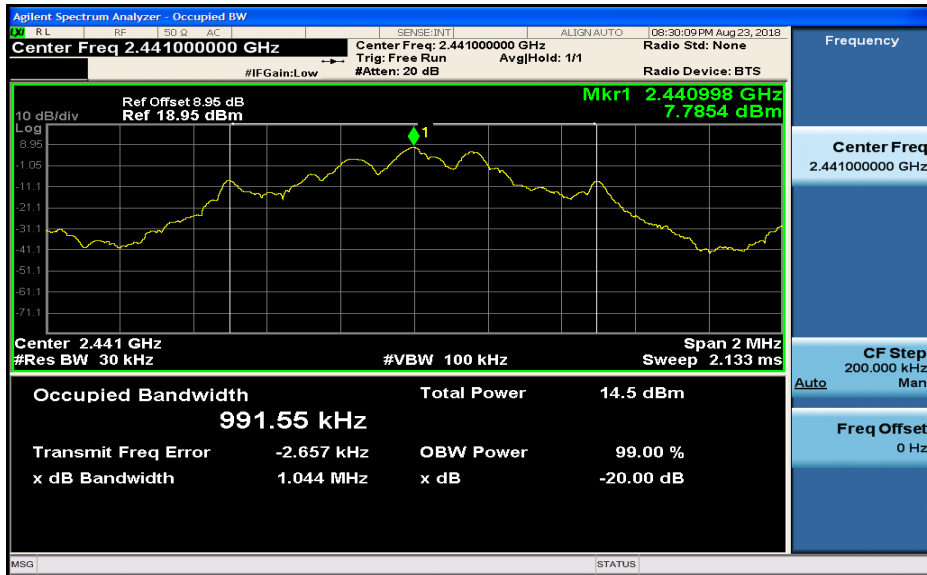

20 dB Bandwidth_DH5_2480

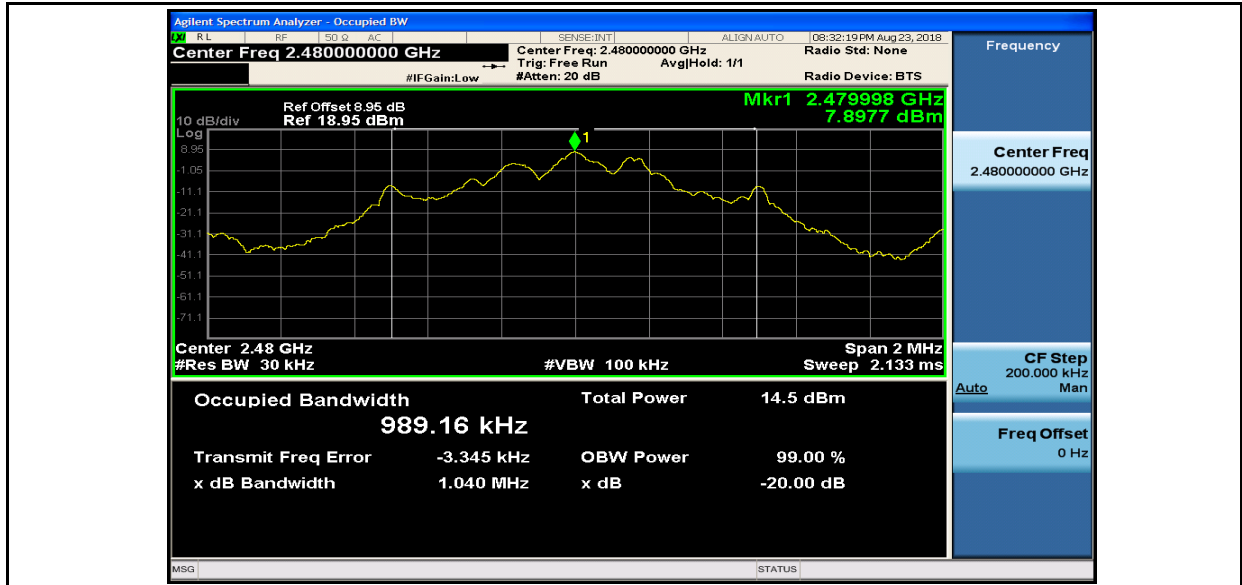

20 dB Bandwidth_2DH5_2402

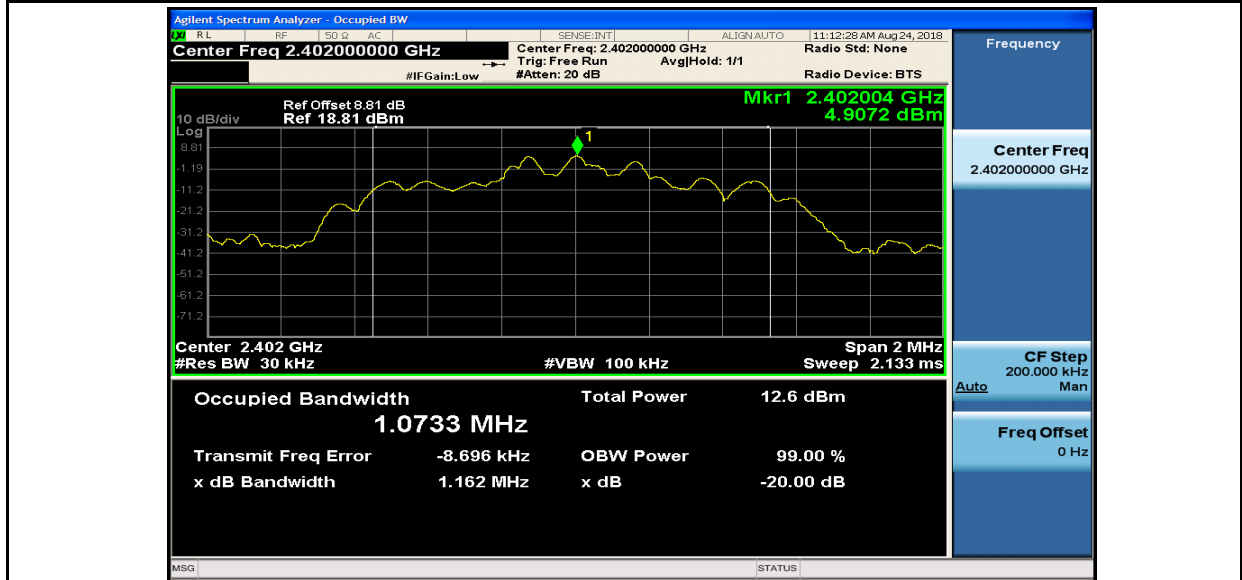

20 dB Bandwidth_2DH5_2441

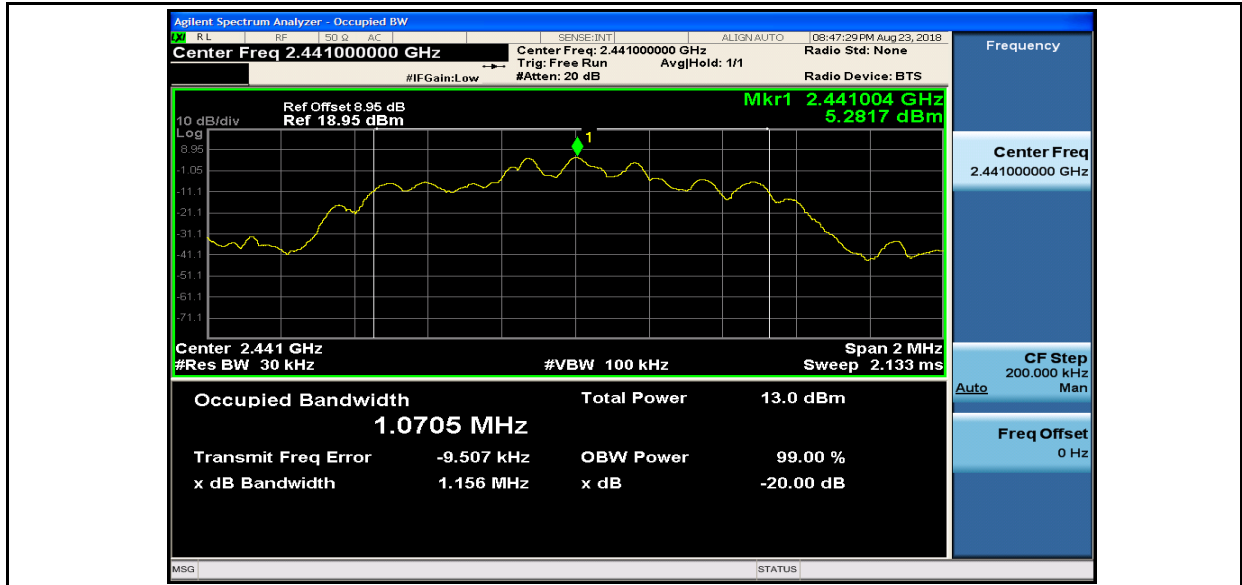

20 dB Bandwidth_2DH5_2480

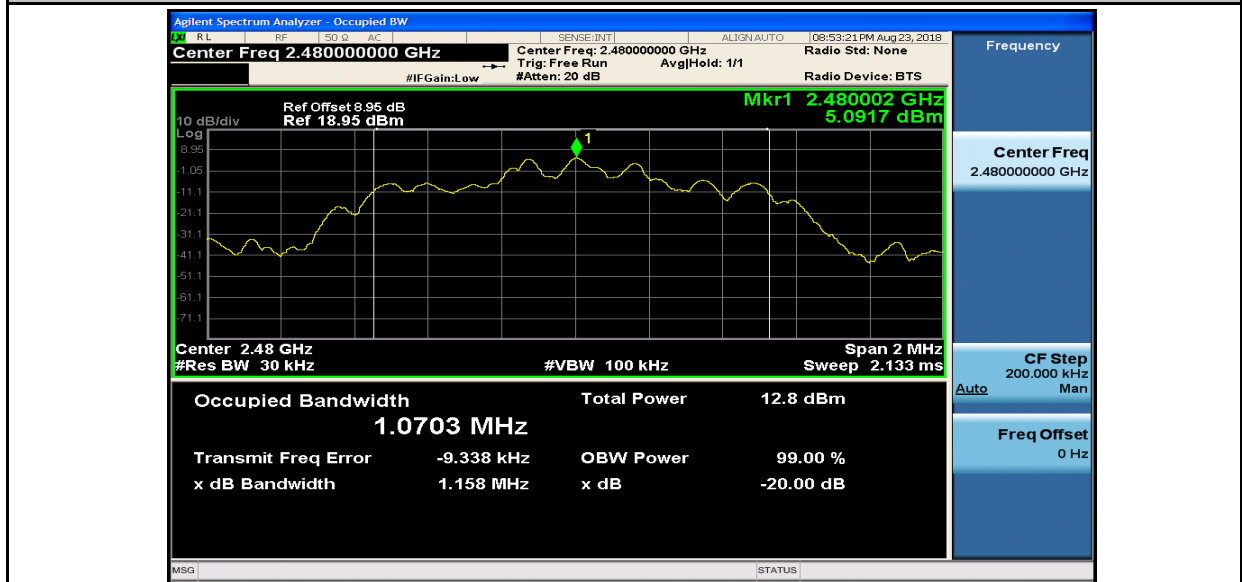

20 dB Bandwidth_3DH5_2402

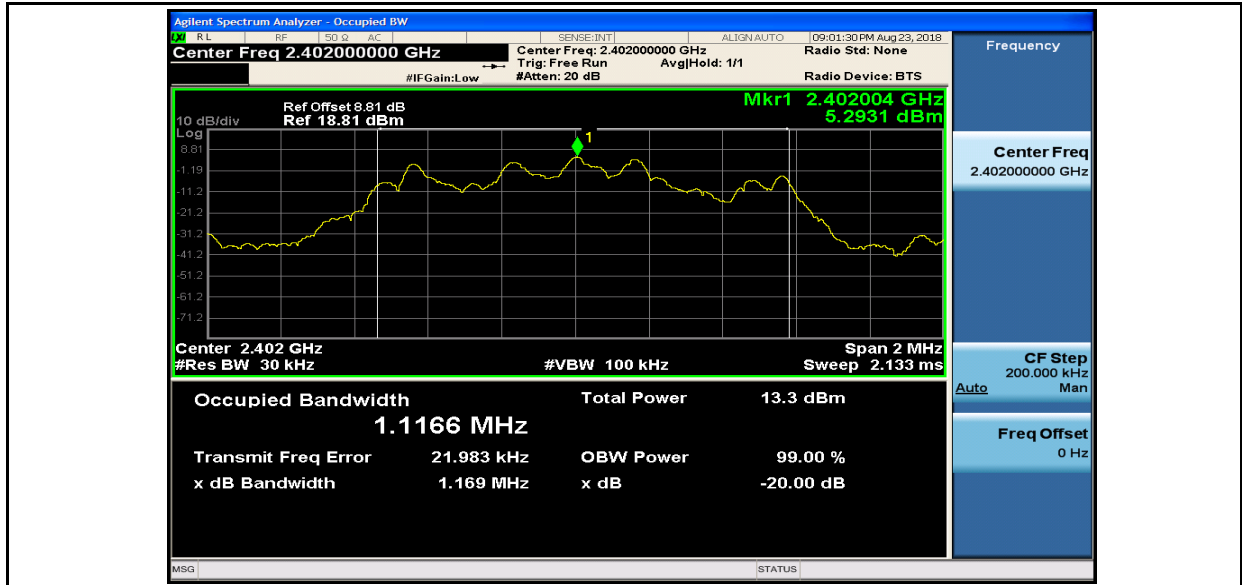

20 dB Bandwidth_3DH5_2441

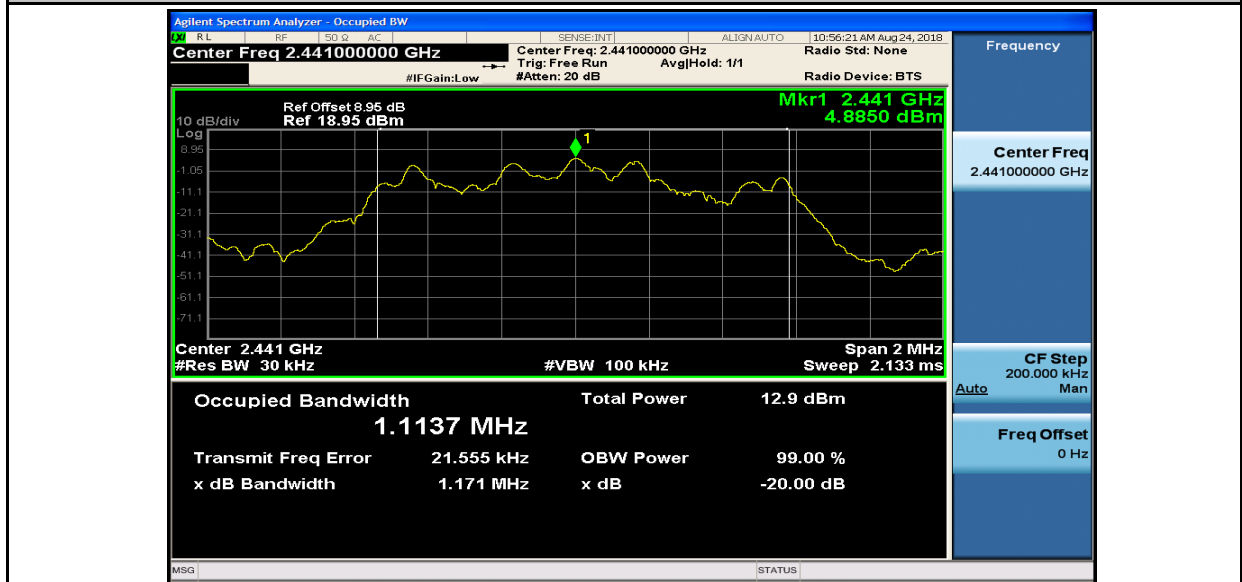

20 dB Bandwidth_3DH5_2480

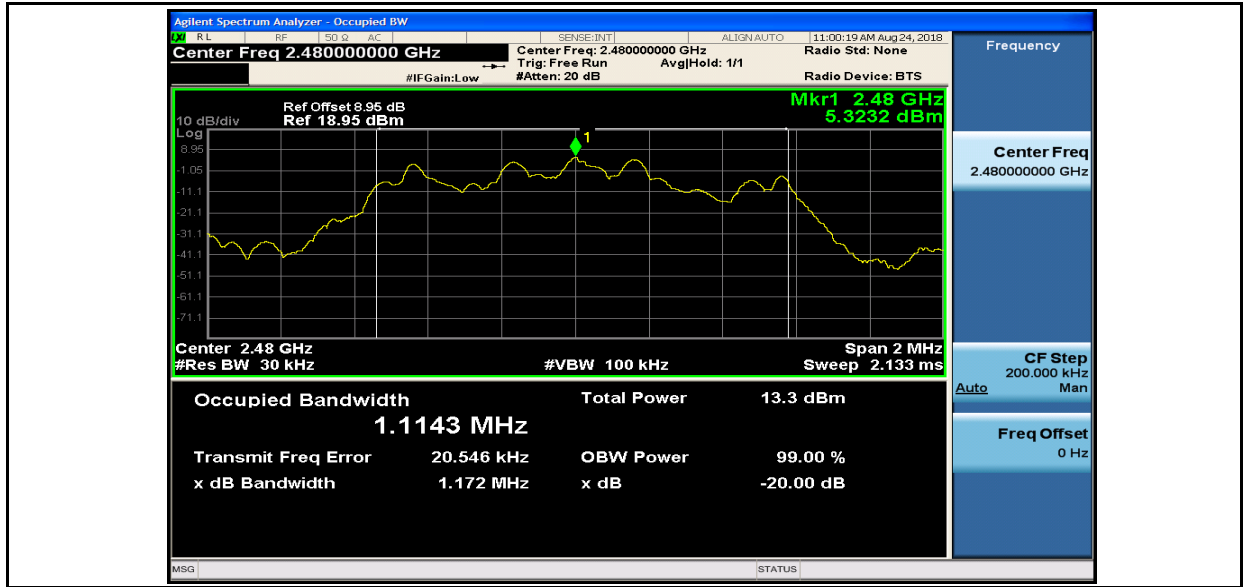



2.Occupied Bandwidth

Test Mode	Test Channel	OBW[MHz]	Limit[MHz]	Verdict
DH5	2402	0.99	---	PASS
DH5	2441	0.99	---	PASS
DH5	2480	0.99	---	PASS
2DH5	2402	1.07	---	PASS
2DH5	2441	1.07	---	PASS
2DH5	2480	1.07	---	PASS
3DH5	2402	1.12	---	PASS
3DH5	2441	1.11	---	PASS
3DH5	2480	1.11	---	PASS



Occupied Bandwidth_DH5_2402

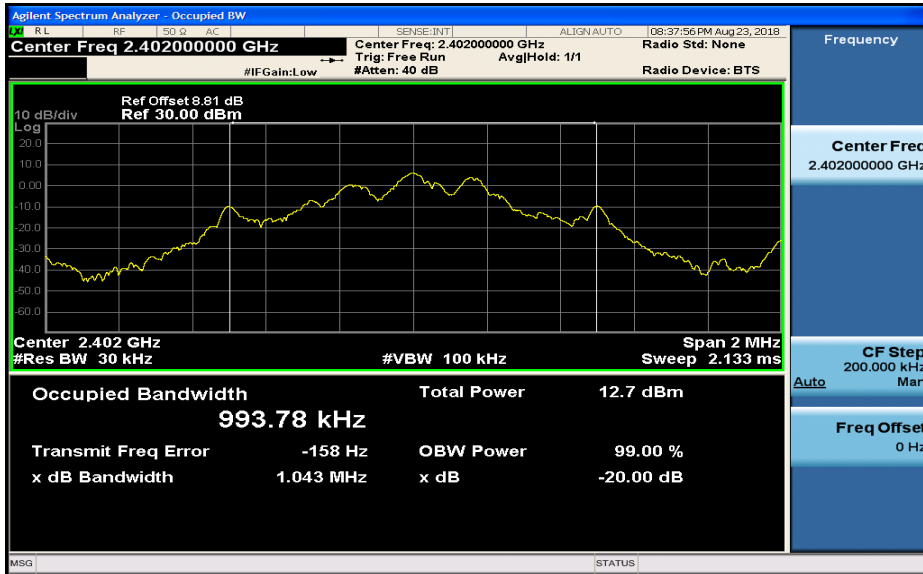

Occupied Bandwidth_DH5_2441

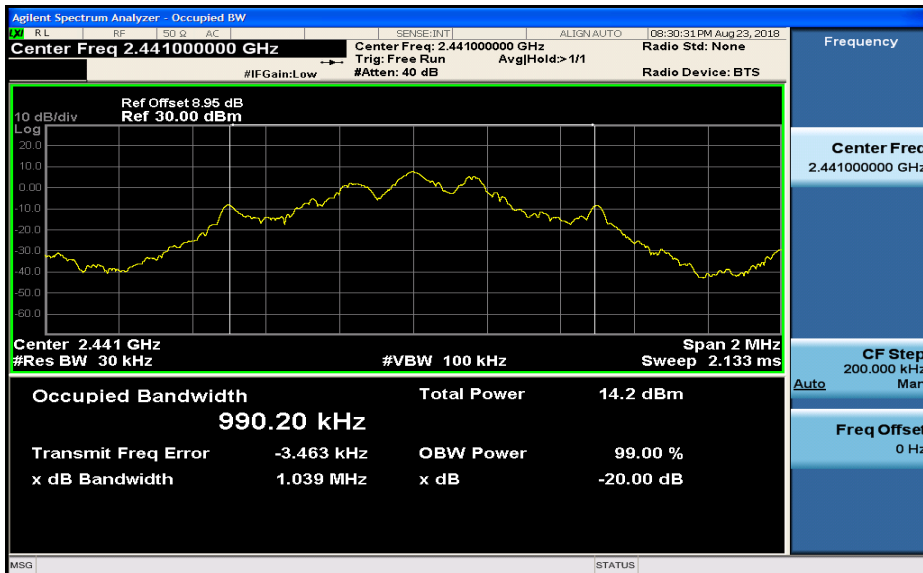

Occupied Bandwidth_DH5_2480

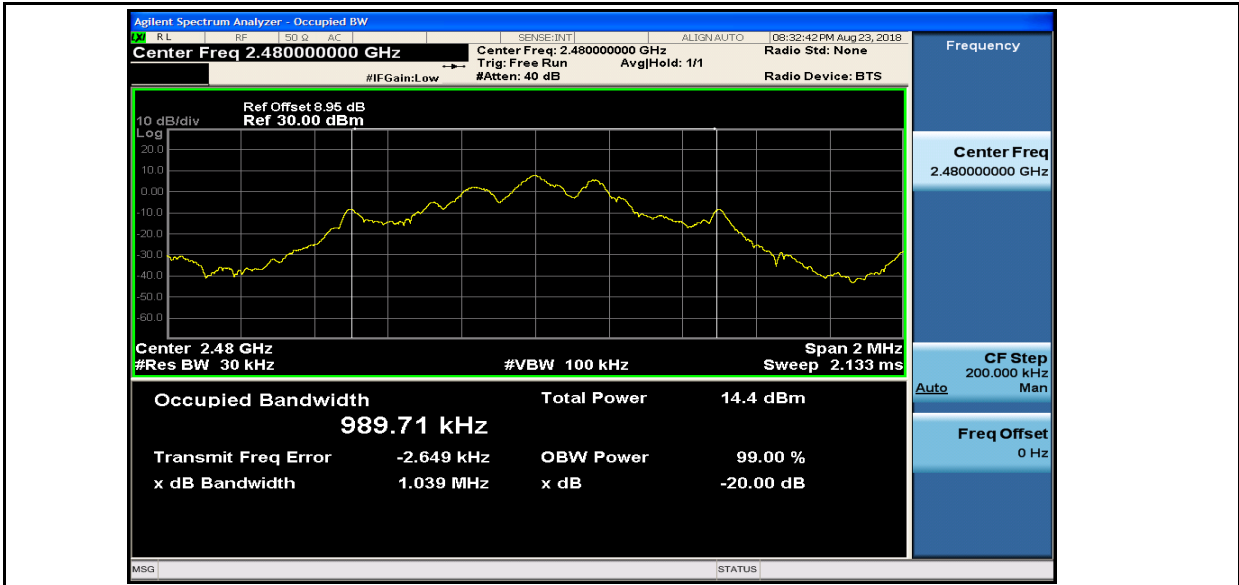

Occupied Bandwidth_2DH5_2402

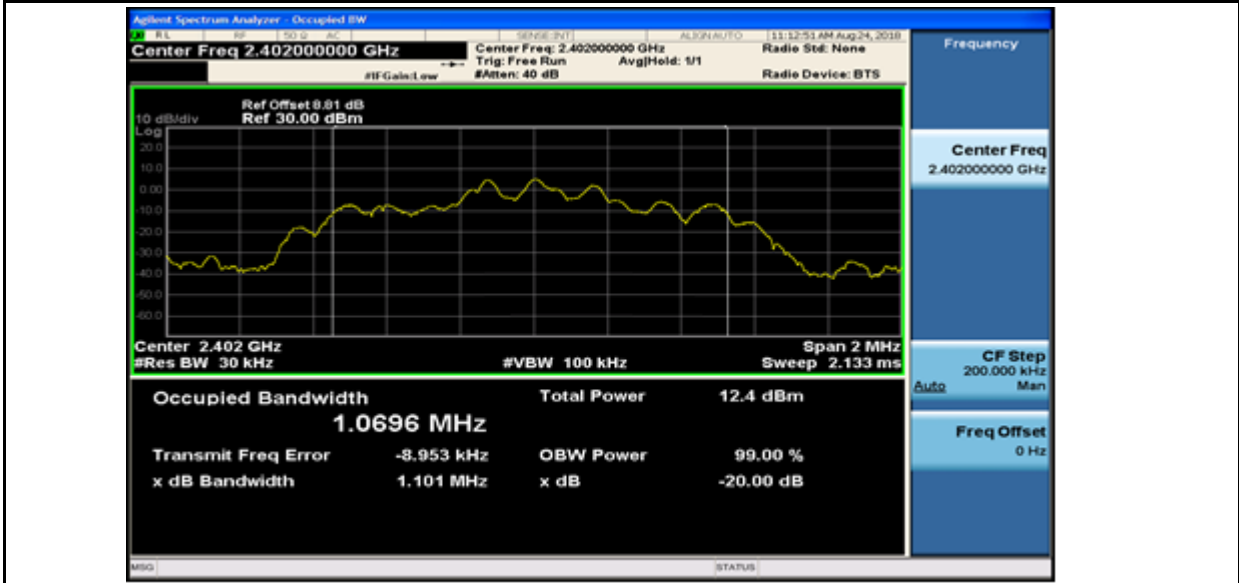

Occupied Bandwidth_2DH5_2441

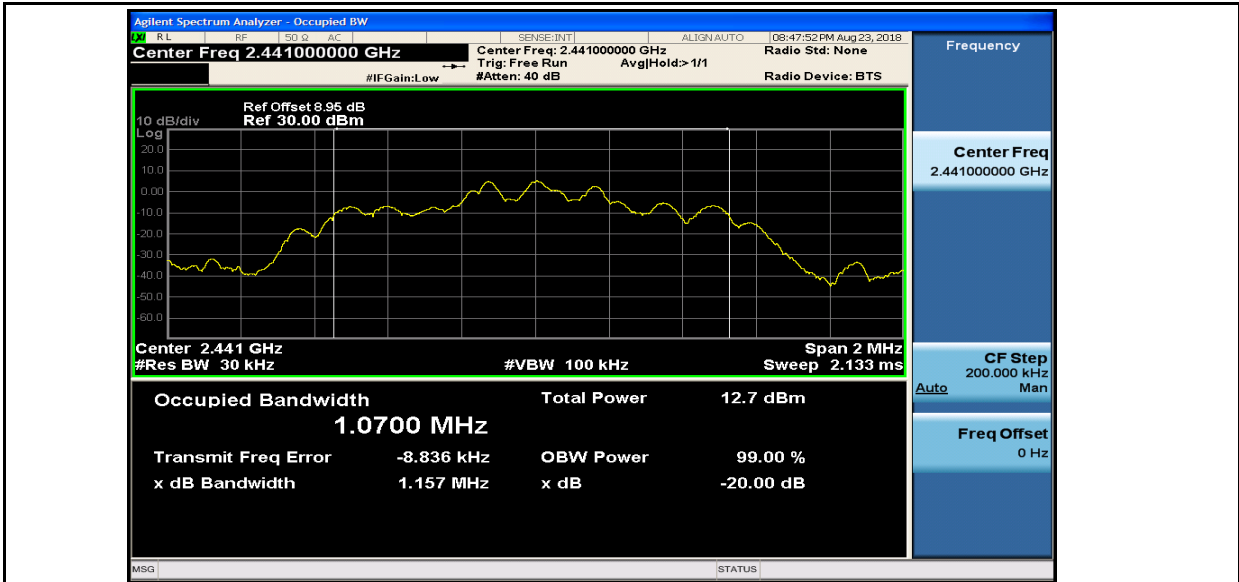

Occupied Bandwidth_2DH5_2480

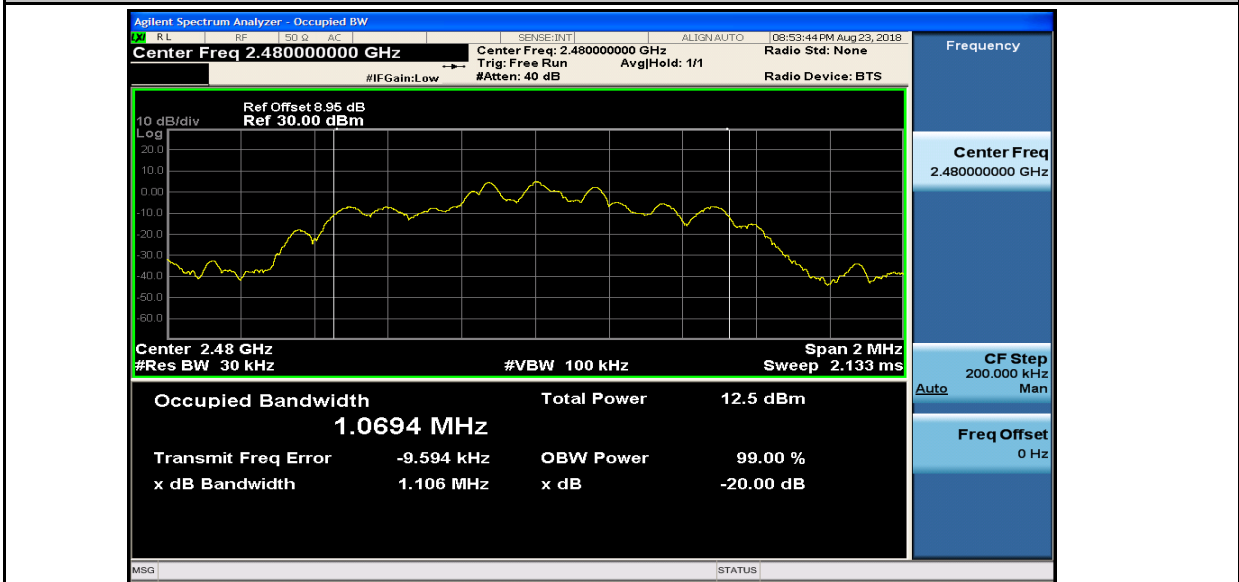

Occupied Bandwidth_3DH5_2402

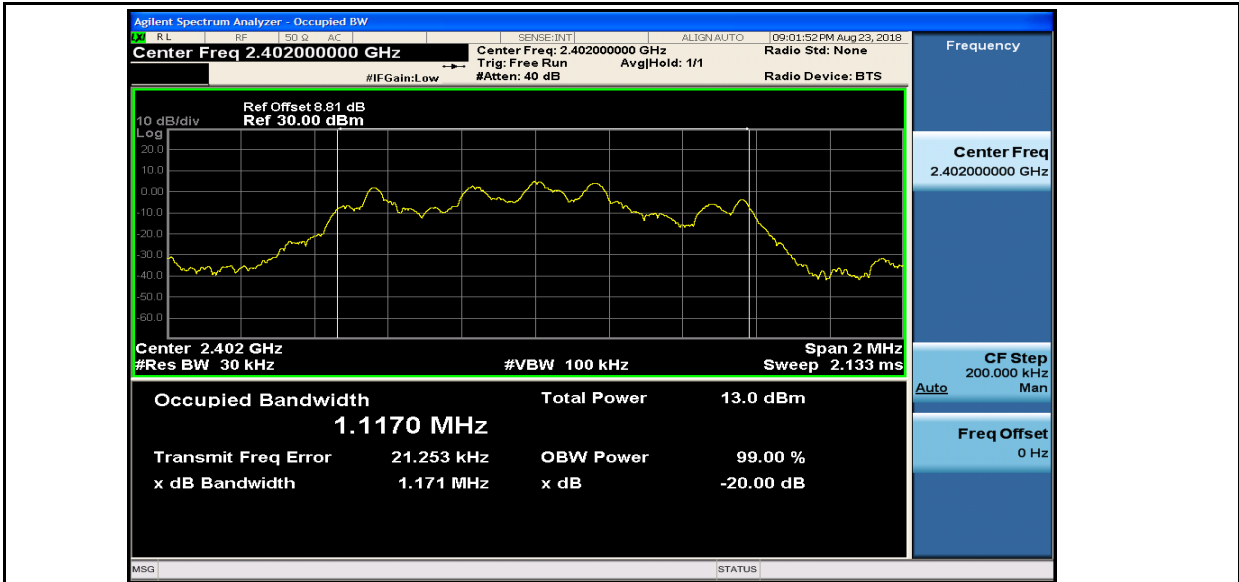

Occupied Bandwidth_3DH5_2441

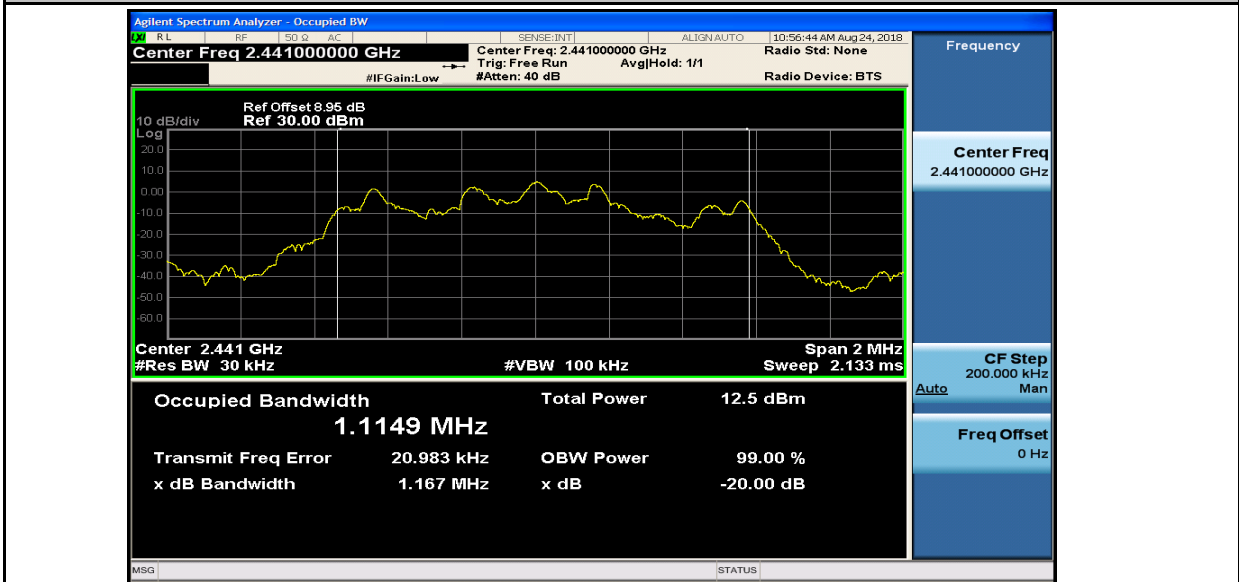

Occupied Bandwidth_3DH5_2480

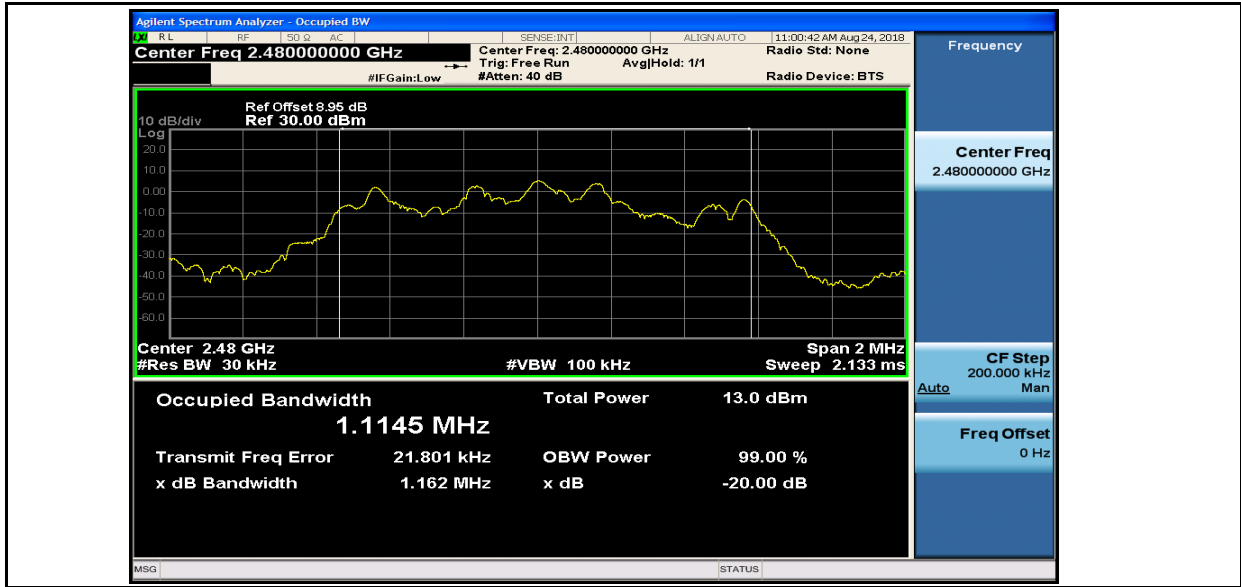



3. Conducted Peak Output Power

Test Mode	Test Channel	Power[dBm]	Limit[dBm]	Verdict
DH5	2402	6.59	21	PASS
DH5	2441	8.09	21	PASS
DH5	2480	8.20	21	PASS
2DH5	2402	6.09	21	PASS
2DH5	2441	6.80	21	PASS
2DH5	2480	6.68	21	PASS
3DH5	2402	6.47	21	PASS
3DH5	2441	6.60	21	PASS
3DH5	2480	7.07	21	PASS



Conducted Peak Output Power_DH5_2402

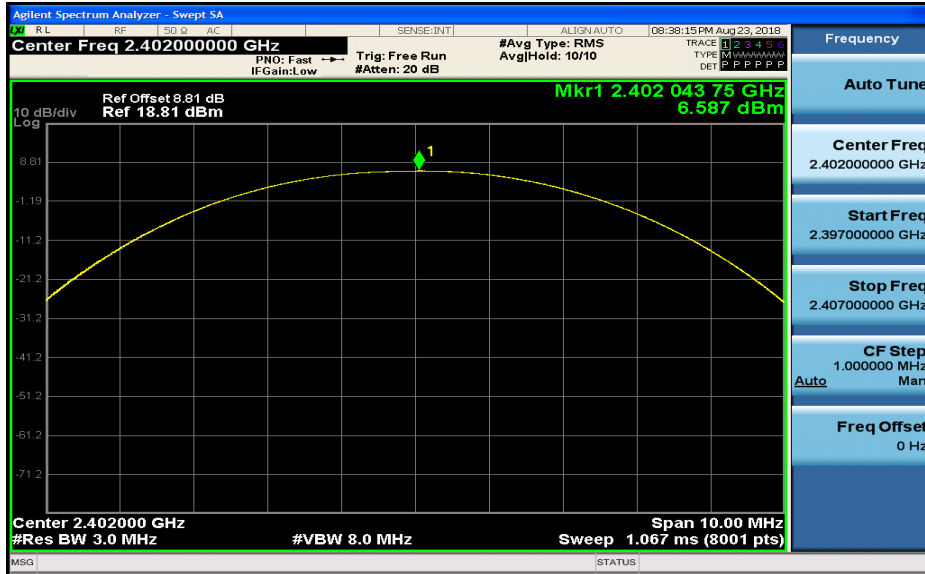

Conducted Peak Output Power_DH5_2441

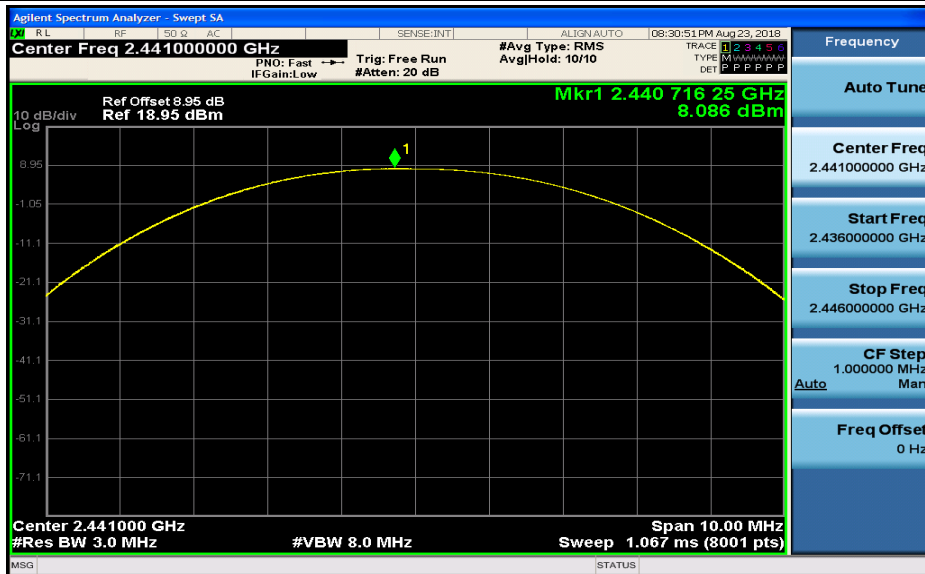

Conducted Peak Output Power_DH5_2480

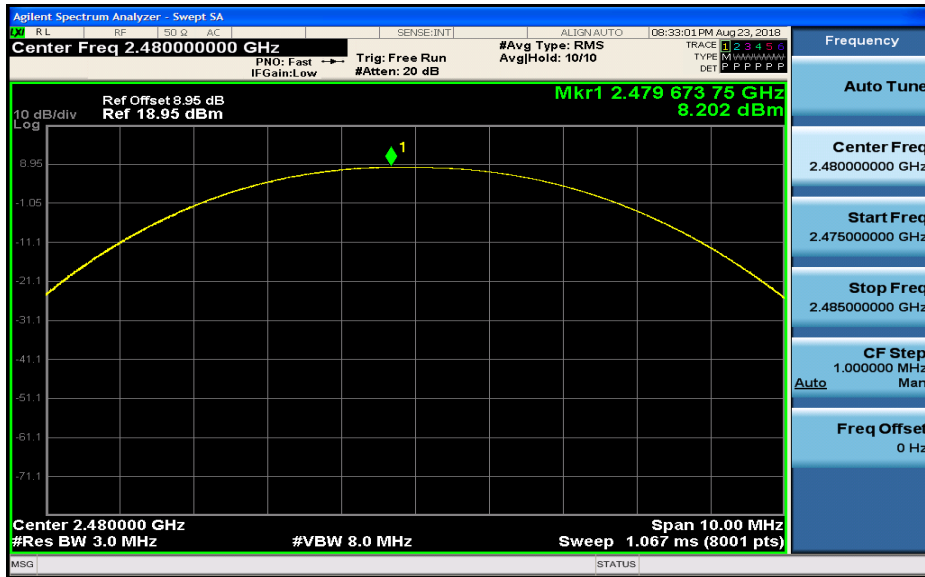

Conducted Peak Output Power_2DH5_2402

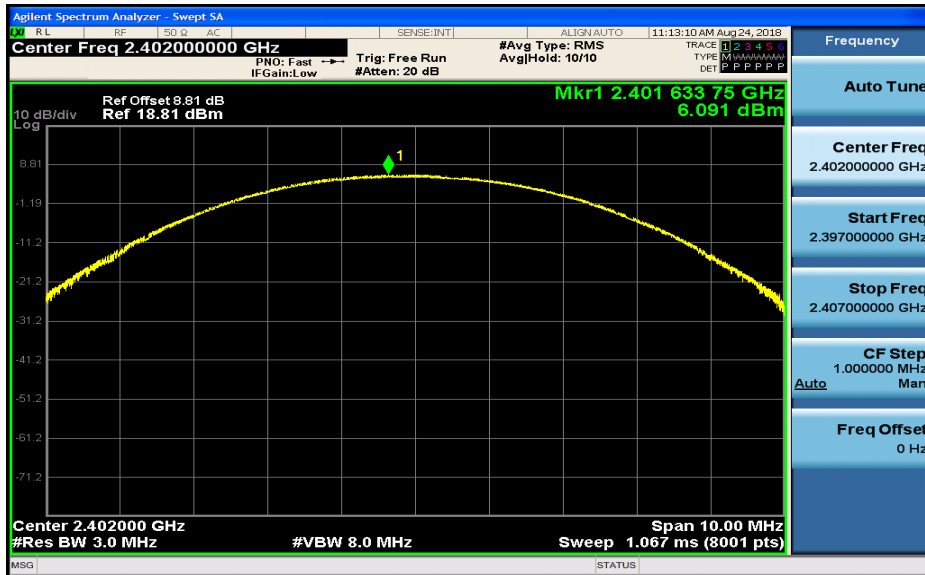

Conducted Peak Output Power_2DH5_2441

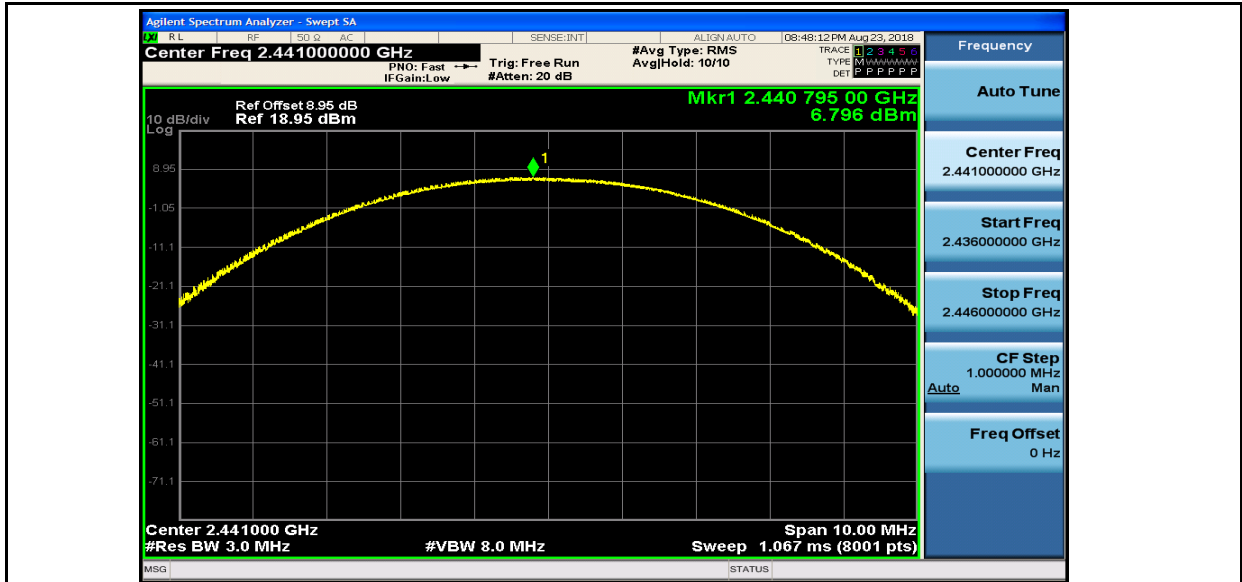

Conducted Peak Output Power_2DH5_2480

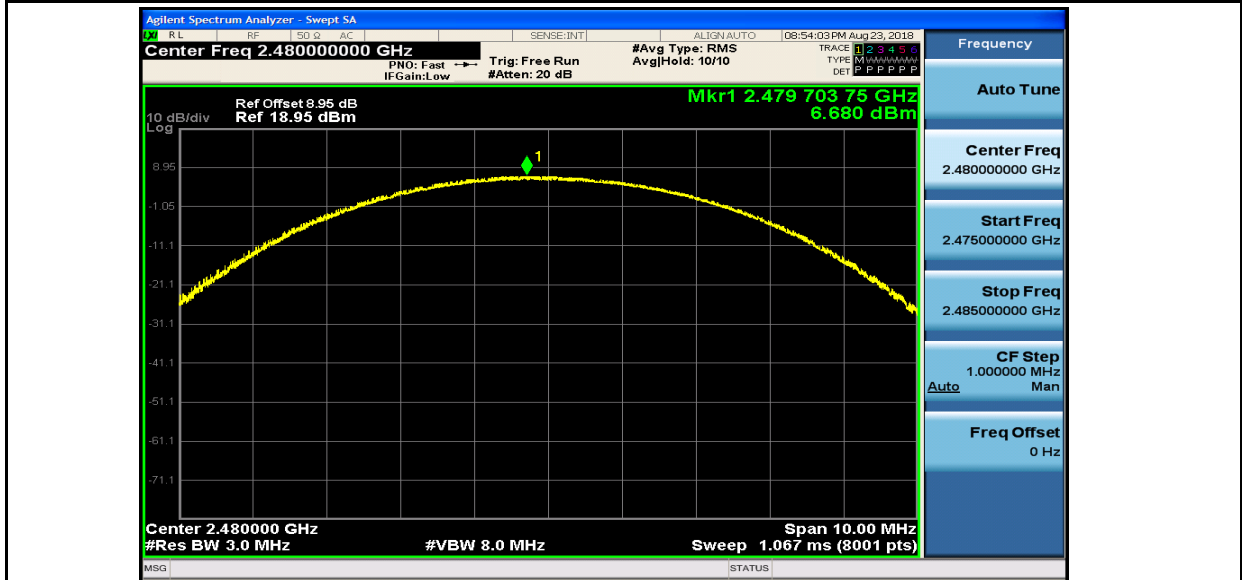

Conducted Peak Output Power_3DH5_2402

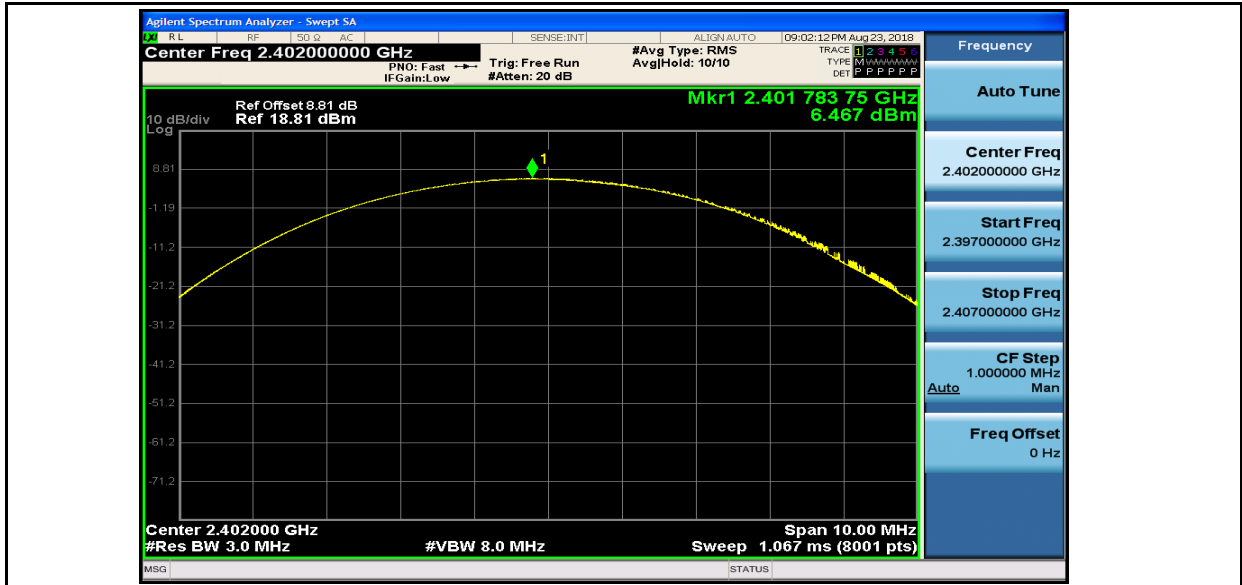

Conducted Peak Output Power_3DH5_2441

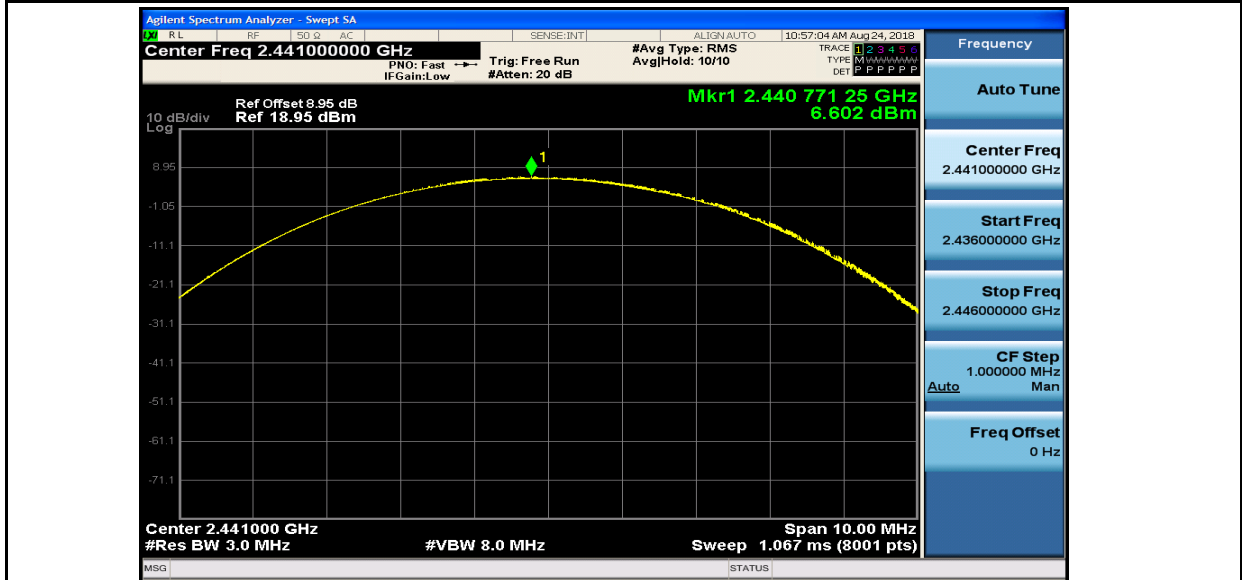

Conducted Peak Output Power_3DH5_2480

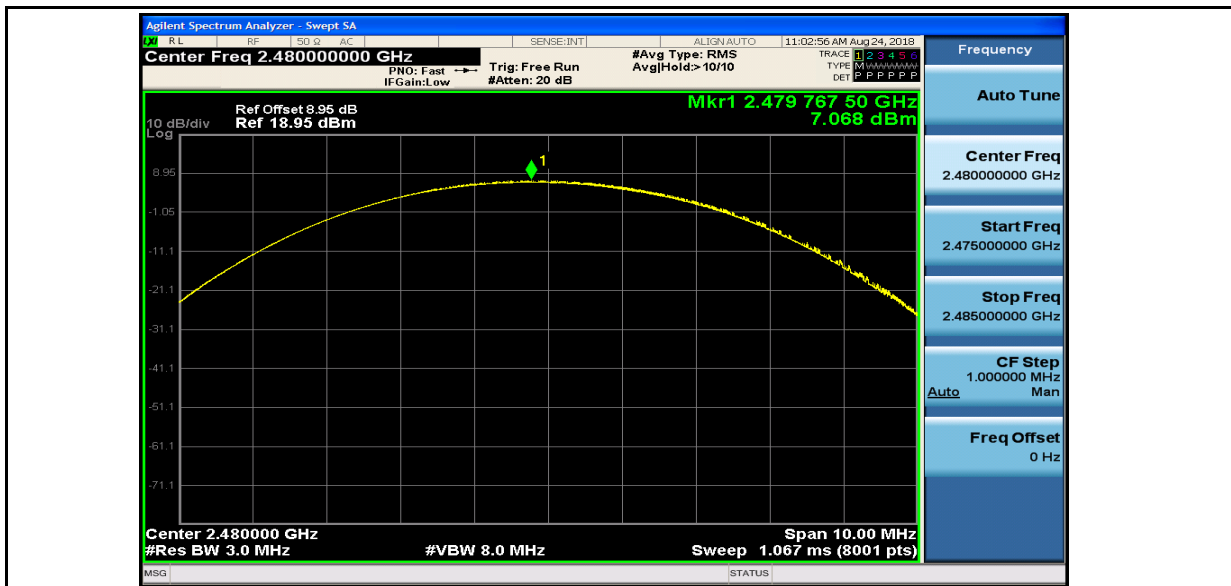



4.Carrier Frequency Separation

Test Mode	Test Channel	Result[MHz]	Limit[MHz]	Verdict
DH5	2441	1.05	0.696	PASS
2DH5	2441	0.97	0.771	PASS
3DH5	2441	1.00	0.781	PASS

Carrier Frequency Separation_DH5_2441



Carrier Frequency Separation_2DH5_2441

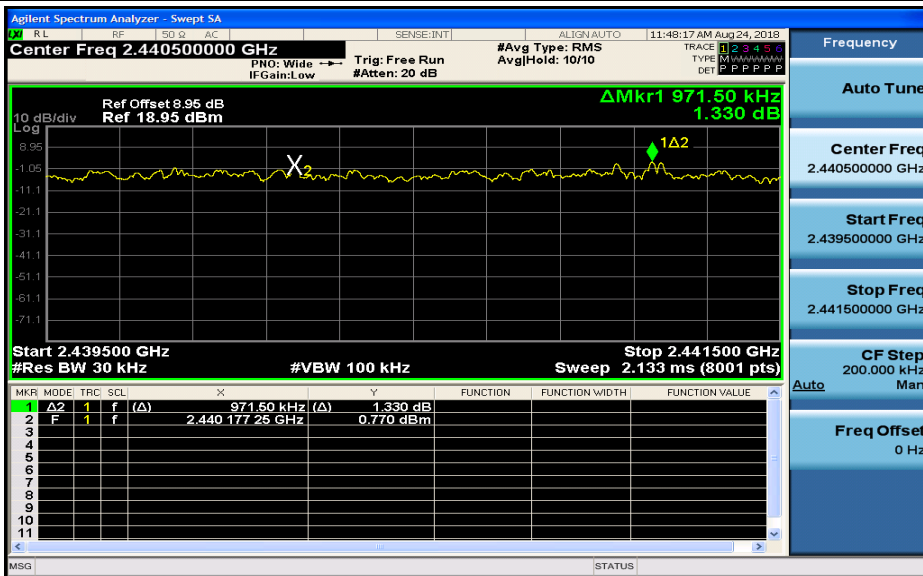

Carrier Frequency Separation_3DH5_2441

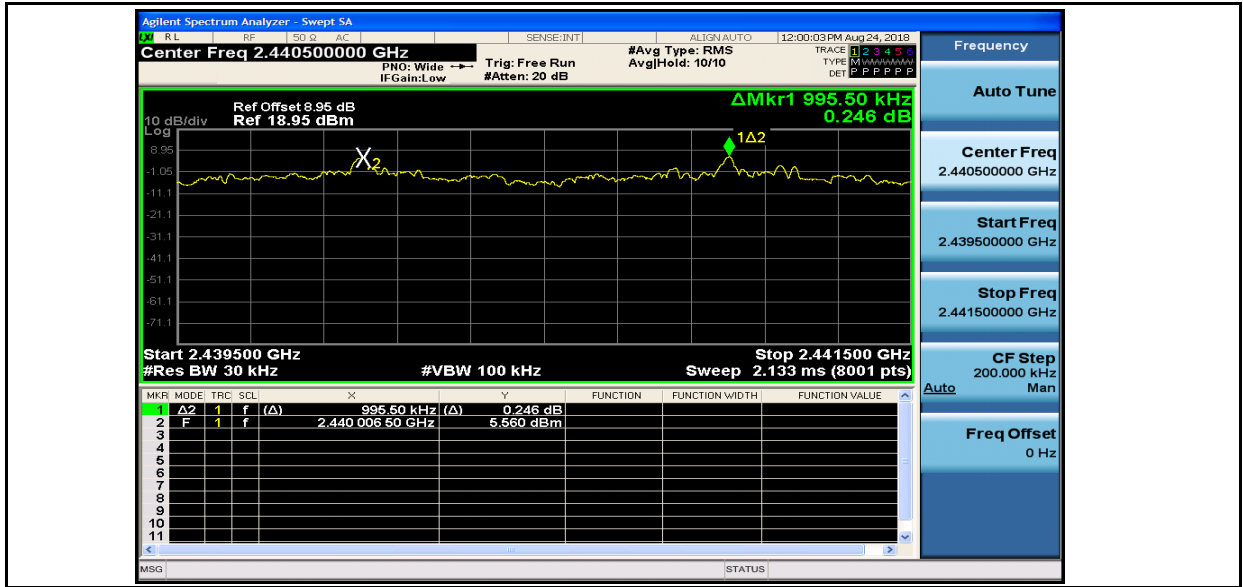



5.Dwell Time

Test Mode	Test Channel	Burst Width[ms/hop/ch]	Total Hops[hop*ch]	Dwell Time[s]	Limit[s]	Verdict
DH1	2441	0.40	320	0.13	0.4	PASS
DH3	2441	1.66	160	0.27	0.4	PASS
DH5	2441	2.90	110	0.32	0.4	PASS
2DH1	2441	0.41	320	0.13	0.4	PASS
2DH3	2441	1.66	160	0.27	0.4	PASS
2DH5	2441	1.71	160	0.27	0.4	PASS
3DH1	2441	0.41	320	0.13	0.4	PASS
3DH3	2441	1.66	160	0.27	0.4	PASS
3DH5	2441	2.91	110	0.32	0.4	PASS



Dwell Time_DH1_2441

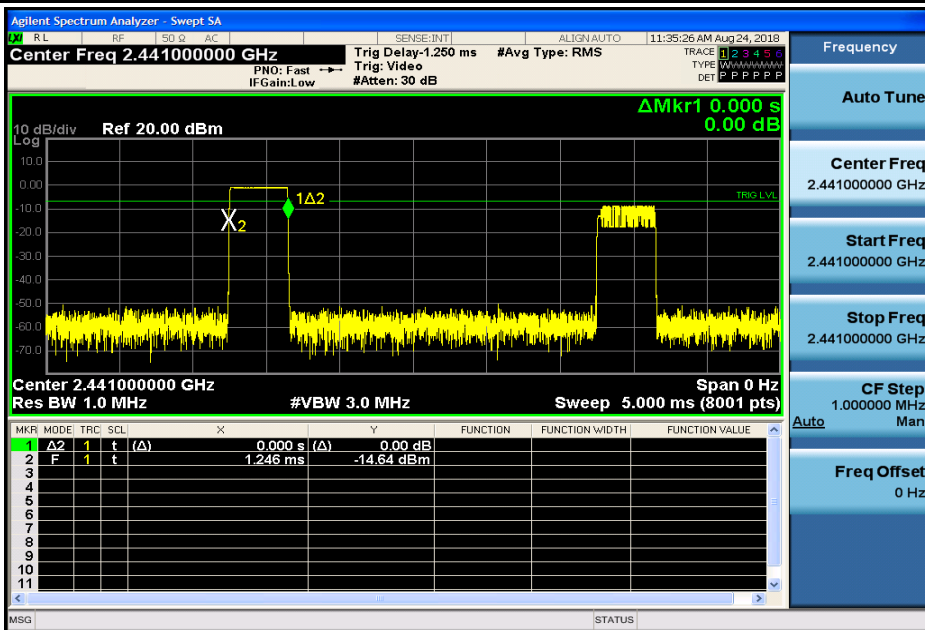

Dwell Time_DH3_2441

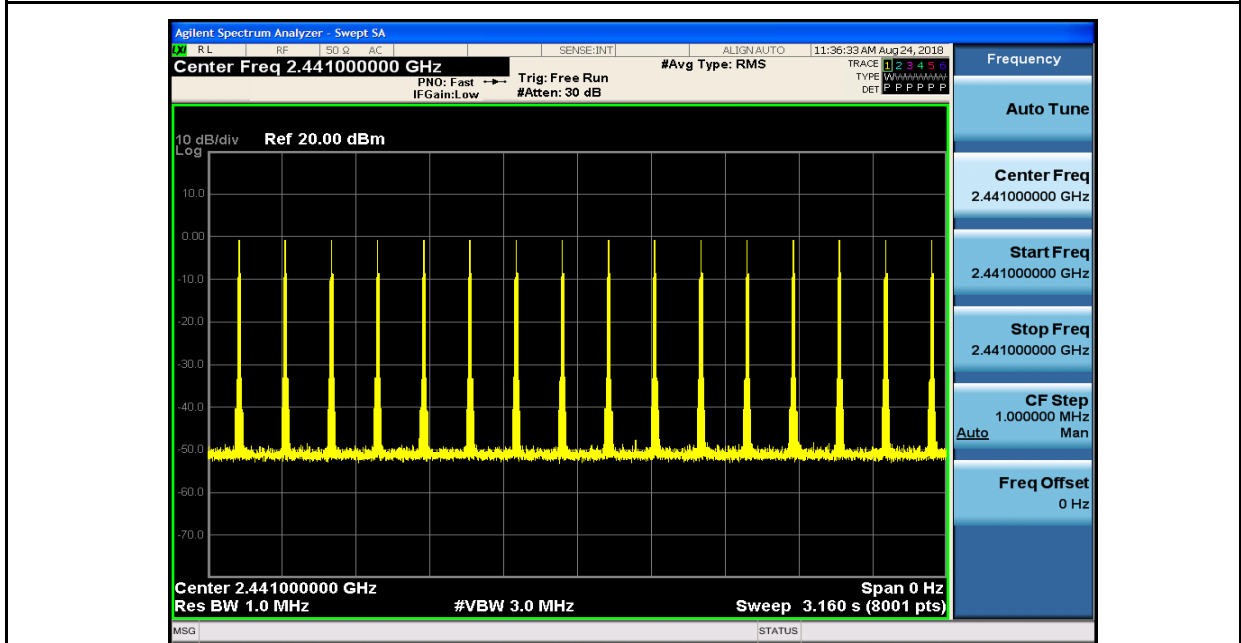
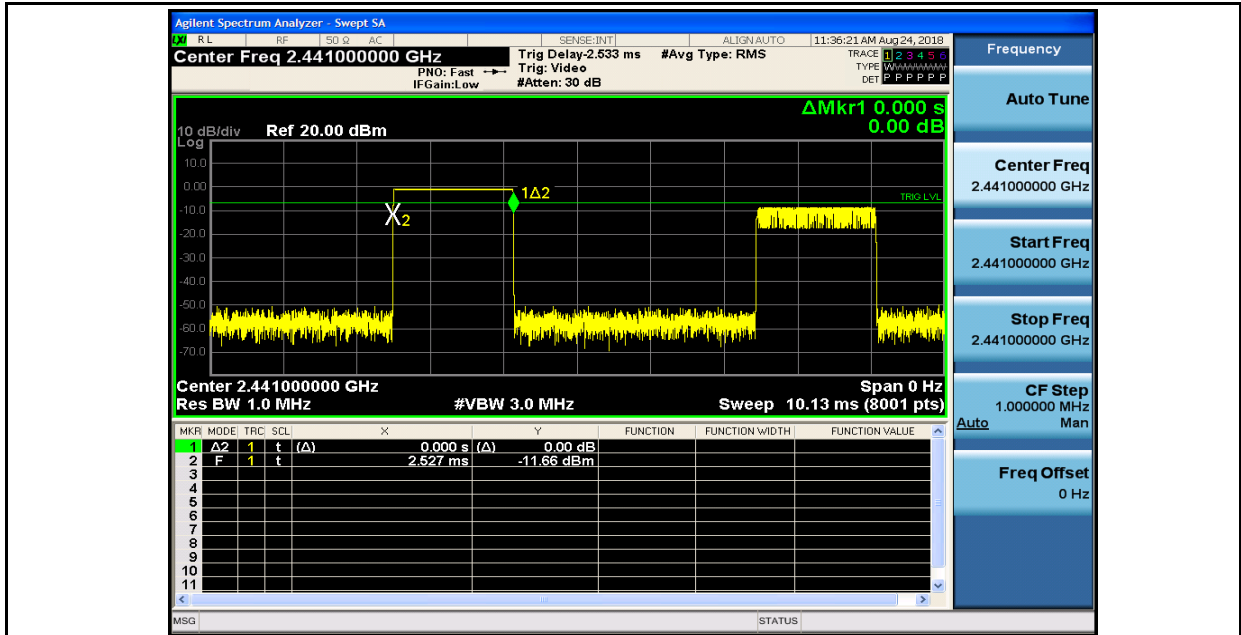

Dwell Time_DH5_2441

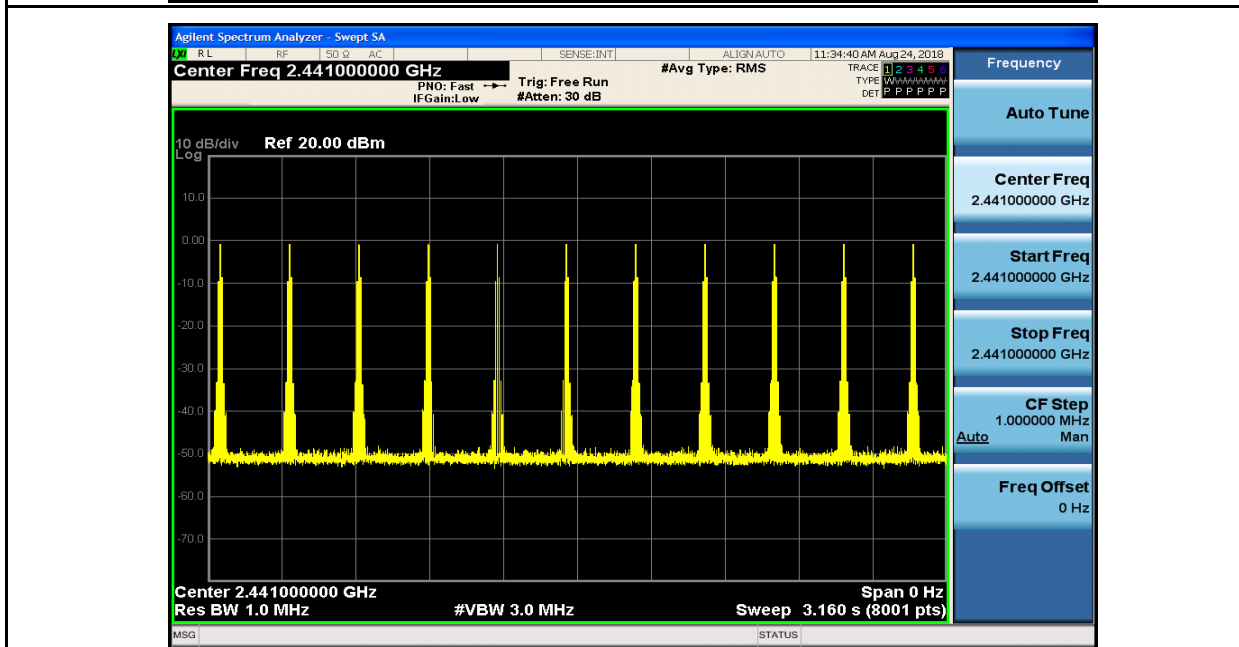
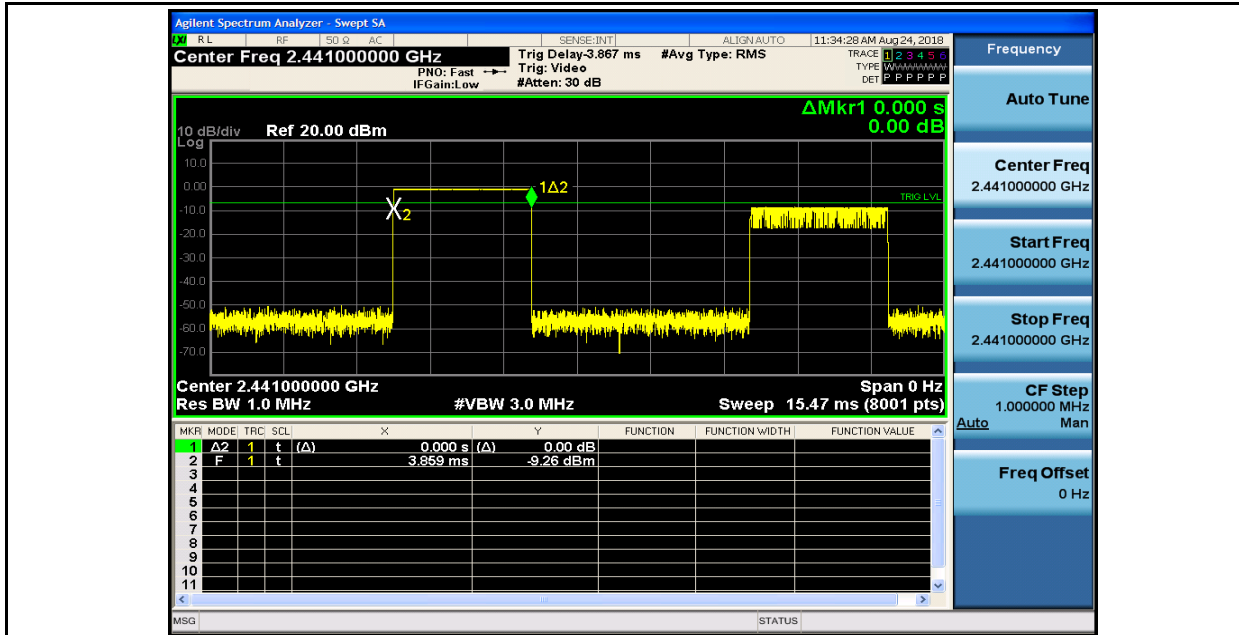

Dwell Time_2DH1_2441

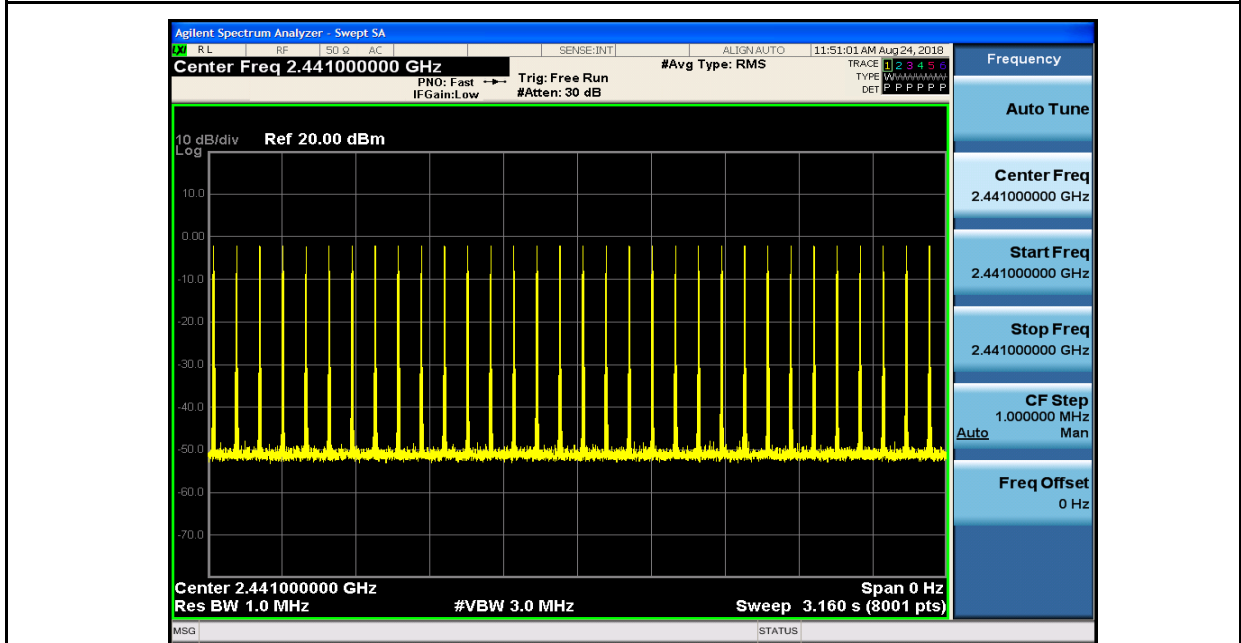
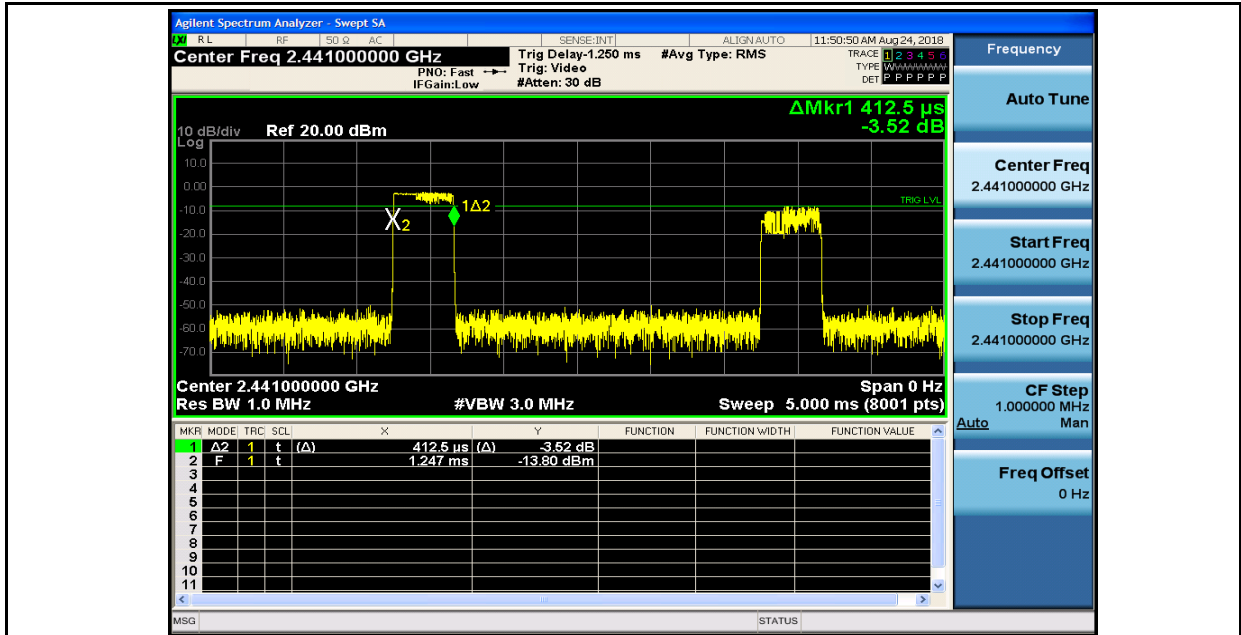

Dwell Time_2DH3_2441

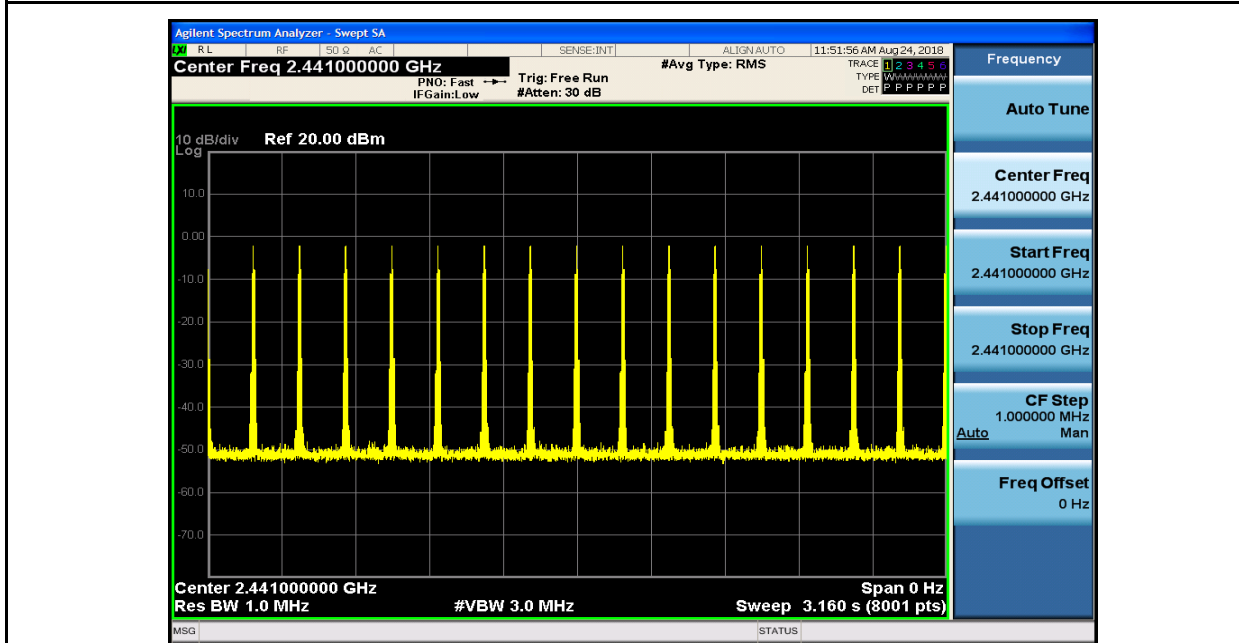
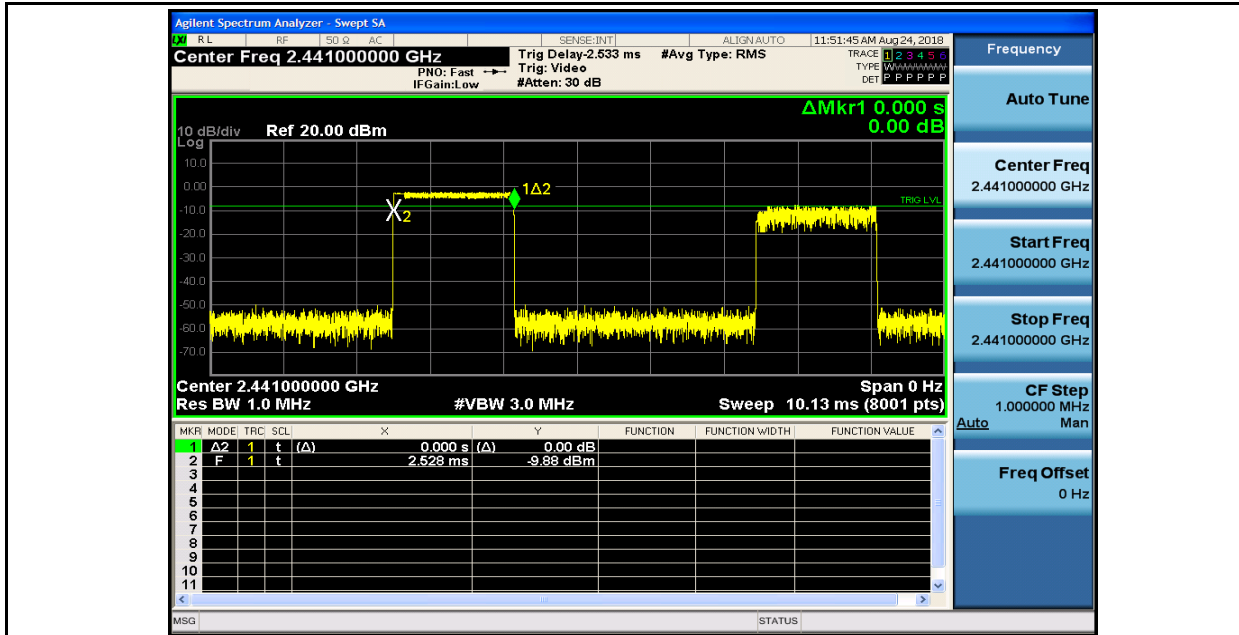

Dwell Time_2DH5_2441

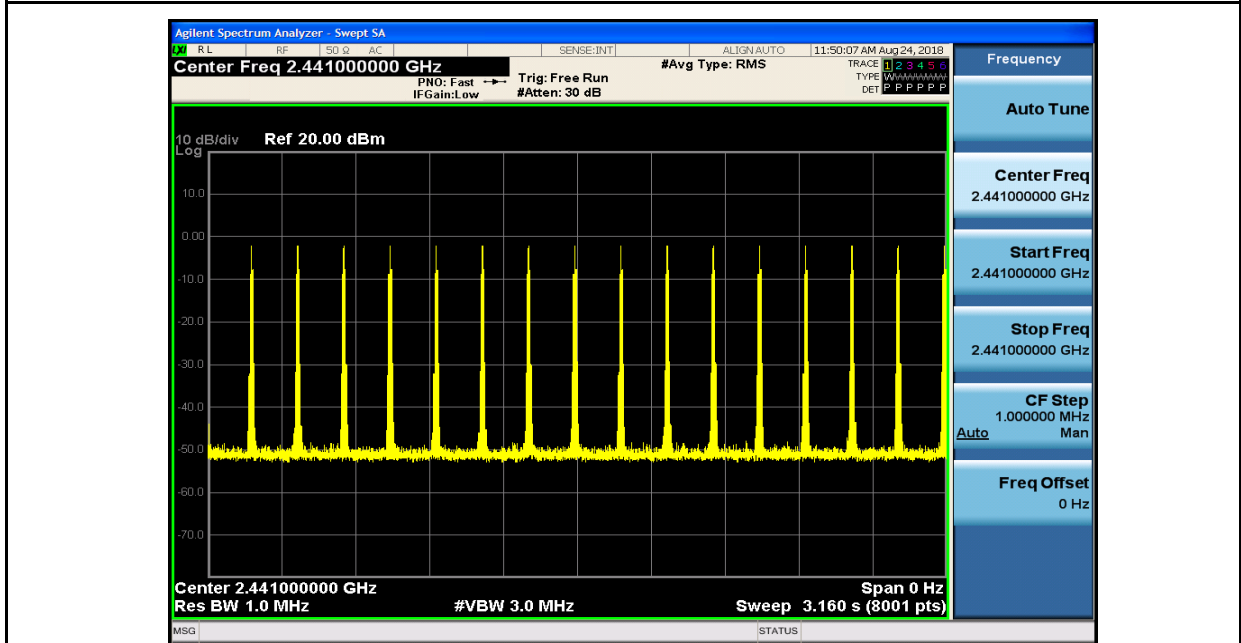
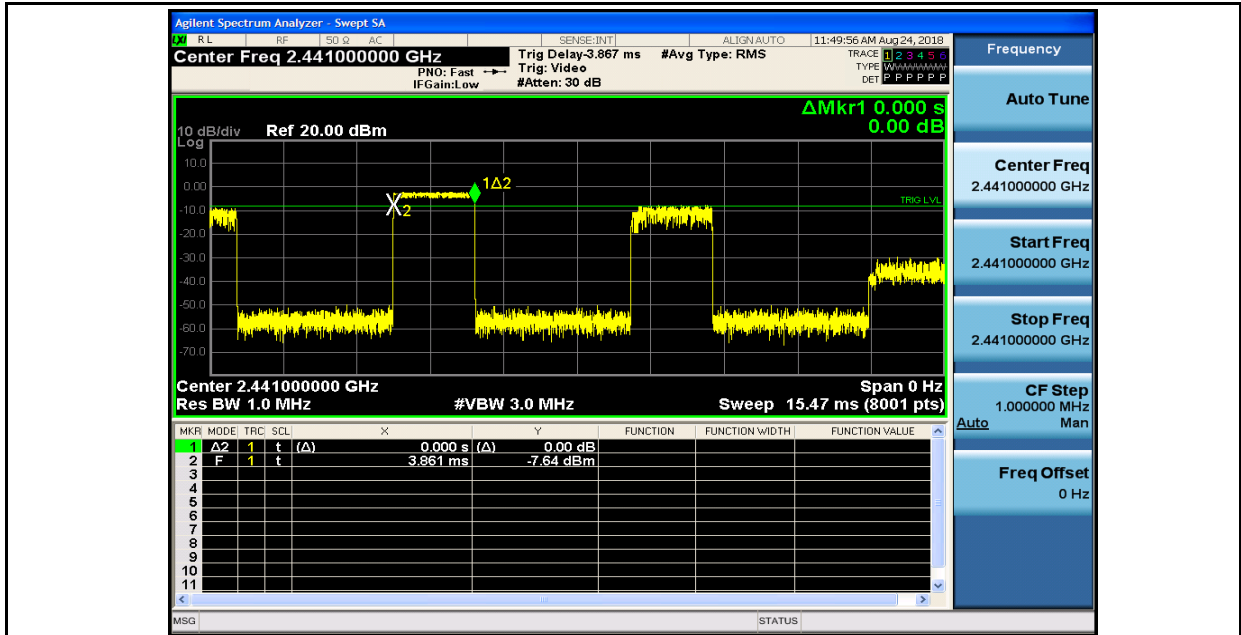

Dwell Time_3DH1_2441

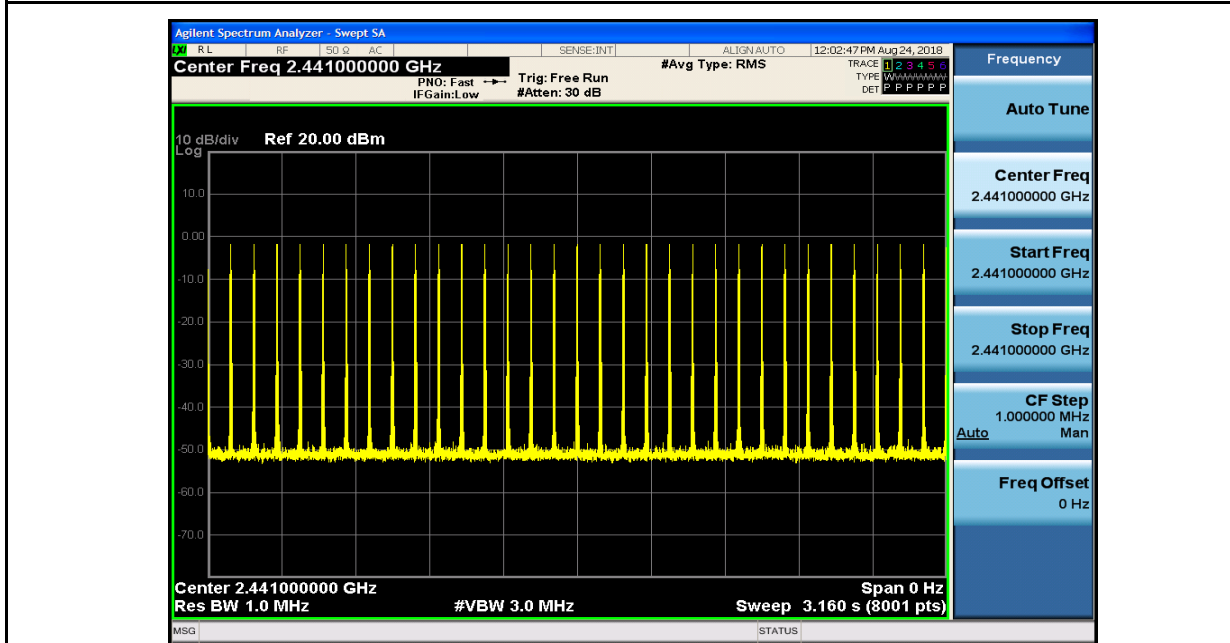
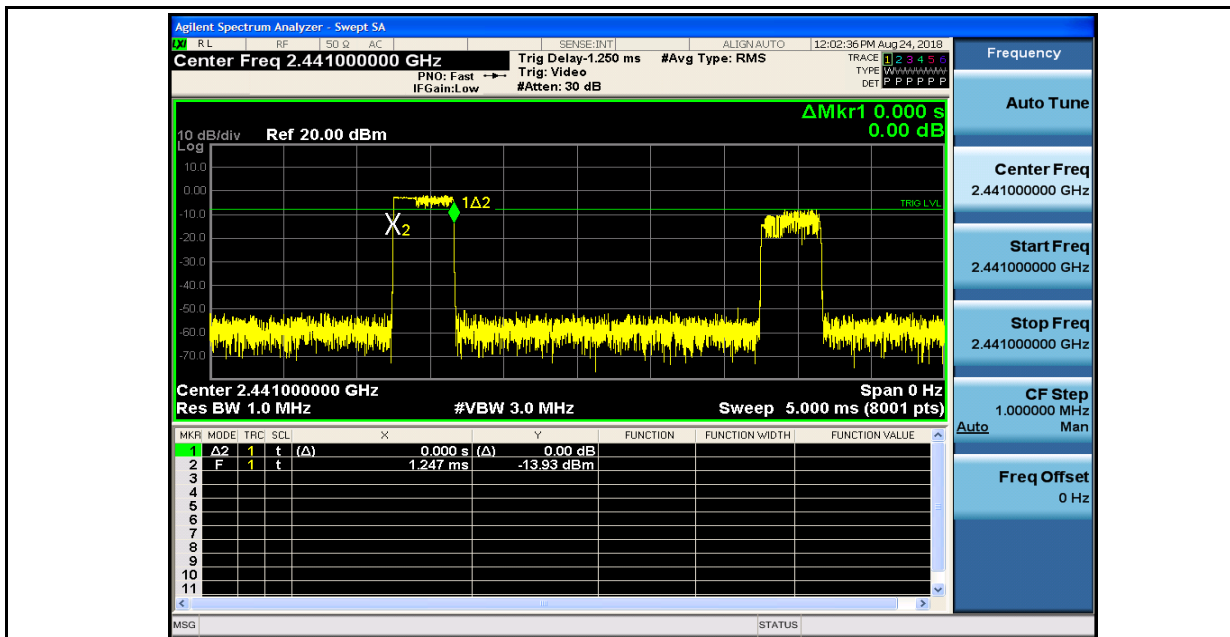

Dwell Time_3DH3_2441

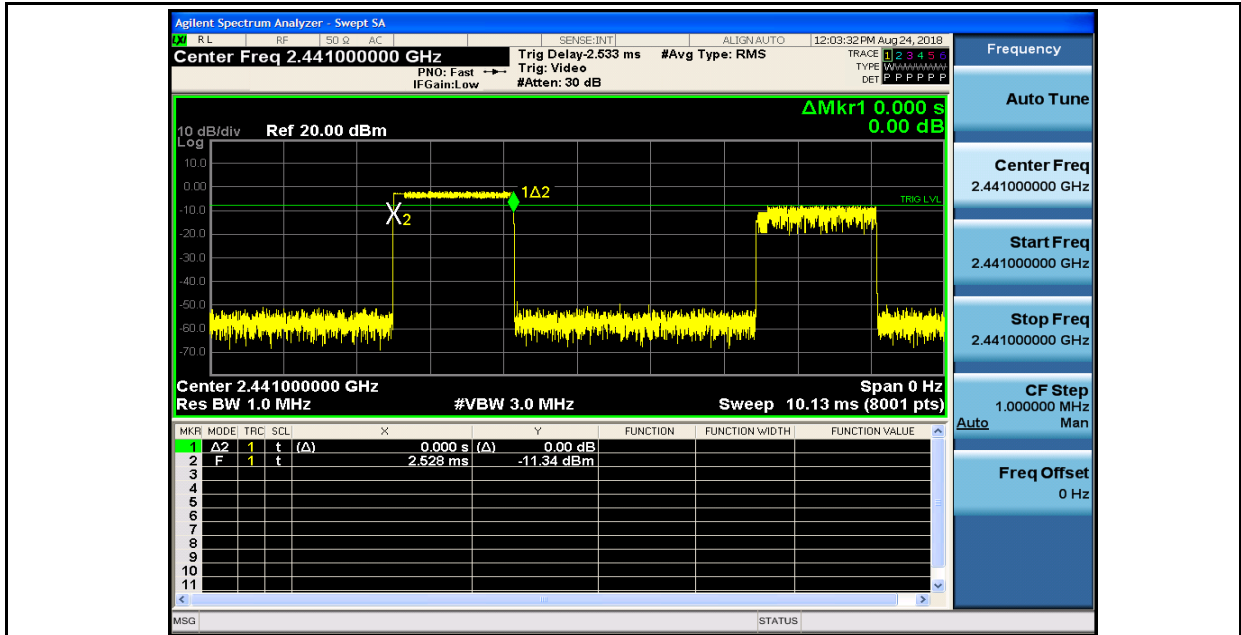

Dwell Time_3DH5_2441

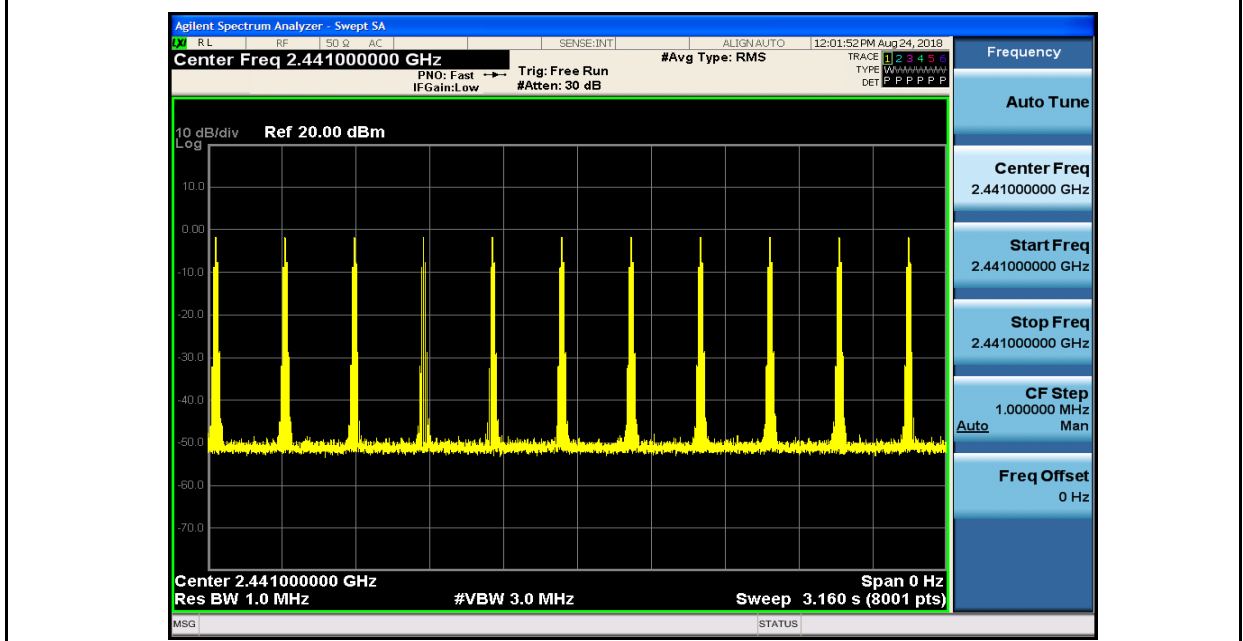
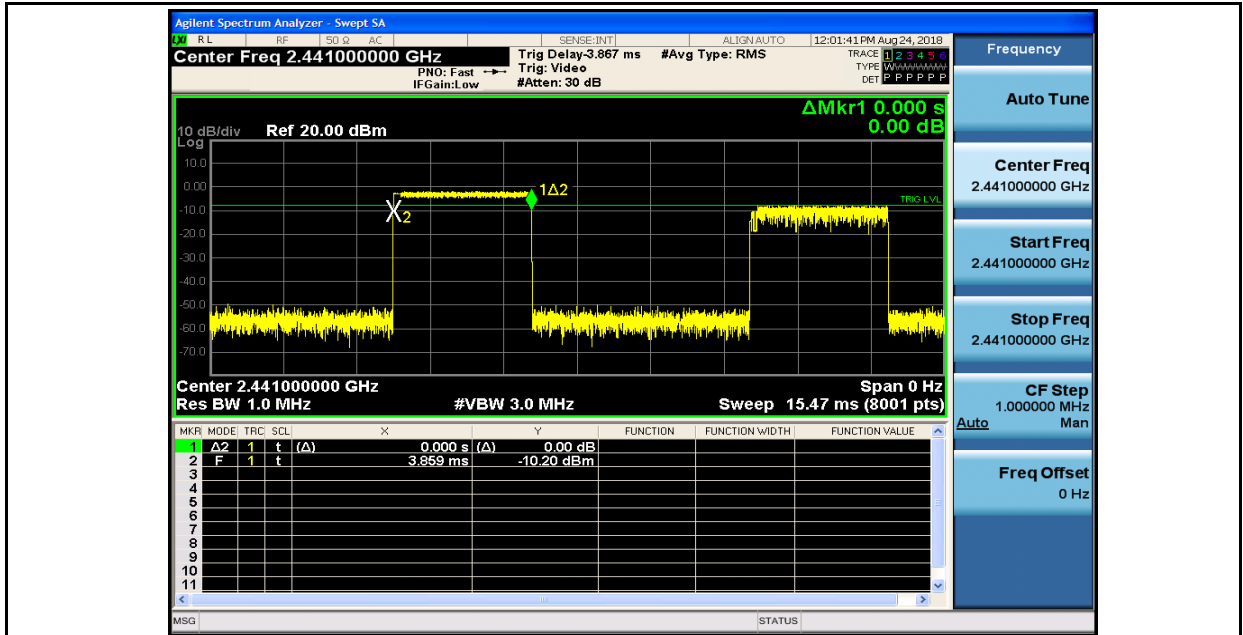



6.Hopping Channel Number

Test Mode	Number of Hopping Channel[N]	Limit[N]	Verdict
DH5	79	≥ 15	PASS
2DH5	79	≥ 15	PASS
3DH5	79	≥ 15	PASS



Hopping Channel Number_DH5

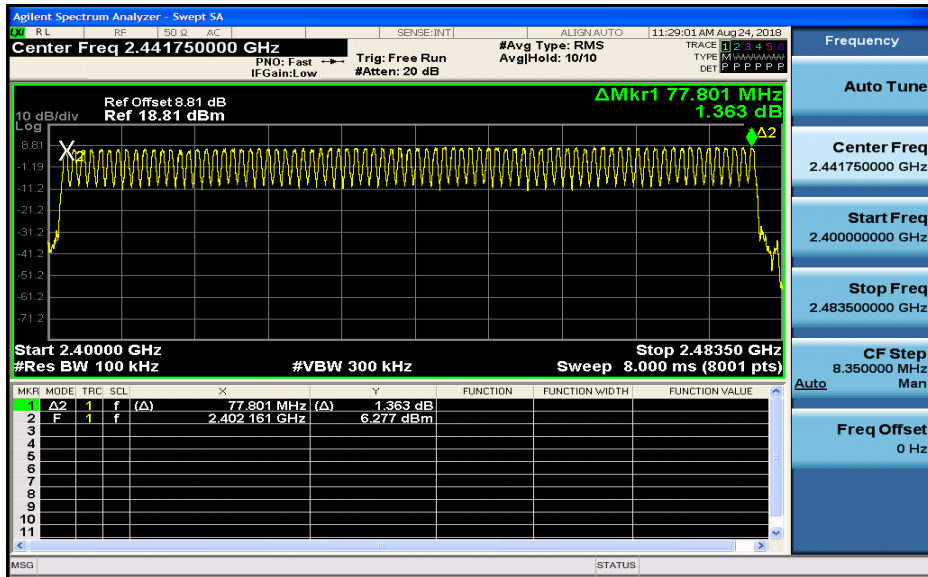

Hopping Channel Number_2DH5

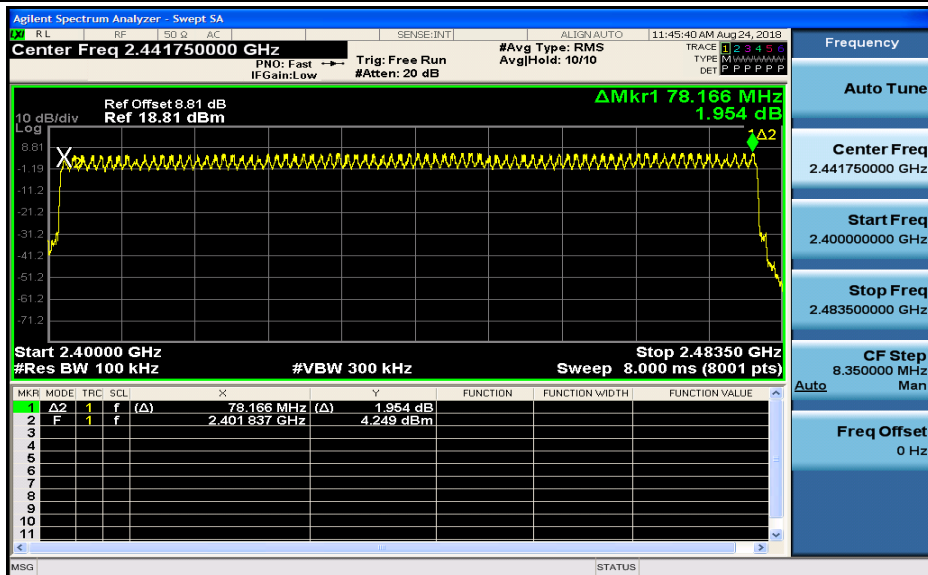

Hopping Channel Number_3DH5

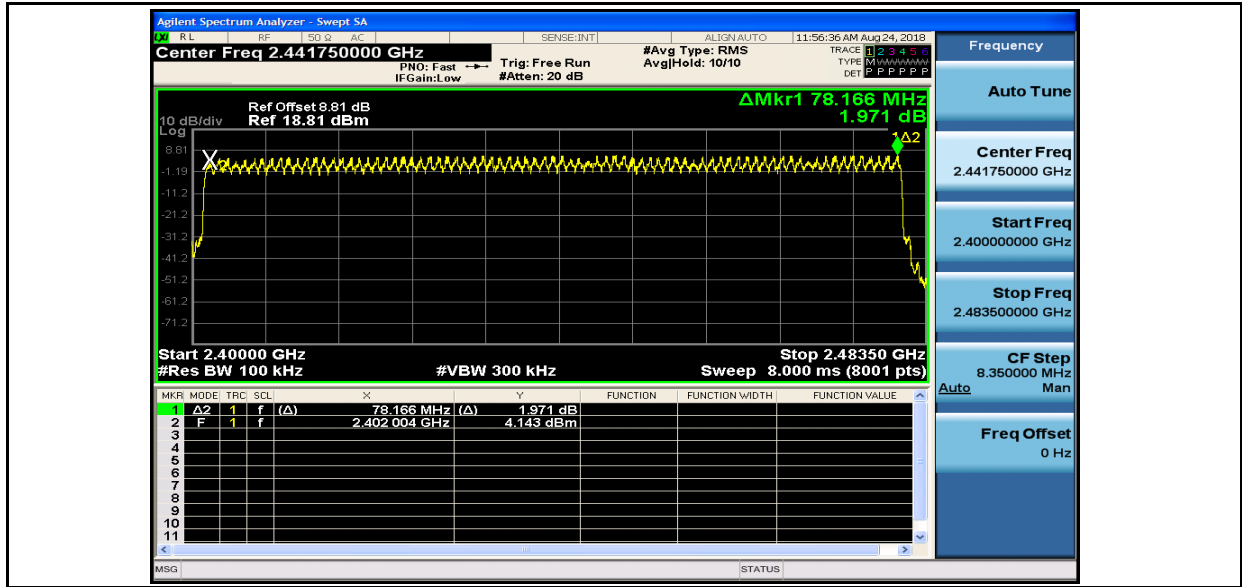

7.Band-edge for RF Conducted Emissions

Test Mode	Test Channel	Hopping	Carrier Power[dBm]	Max. Spurious Level [dBm]	Limit[dBm]	Verdict
DH5	2402	On	7.14	-38.52	-12.86	PASS
DH5	2402	Off	6.45	-35.71	-13.55	PASS
DH5	2480	On	8.21	-53.58	-11.79	PASS
DH5	2480	Off	8.09	-51.92	-11.91	PASS
2DH5	2402	On	5.17	-33.72	-14.83	PASS
2DH5	2402	Off	5.43	-32.23	-14.57	PASS
2DH5	2480	On	6.35	-56.38	-13.65	PASS
2DH5	2480	Off	5.62	-53.94	-14.38	PASS
3DH5	2402	On	5.15	-33.48	-14.85	PASS
3DH5	2402	Off	5.81	-31.99	-14.19	PASS
3DH5	2480	On	6.29	-53.14	-13.71	PASS
3DH5	2480	Off	5.93	-48.10	-14.07	PASS



Band-edge for RF Conducted Emissions_DH5_2402_Hopping On

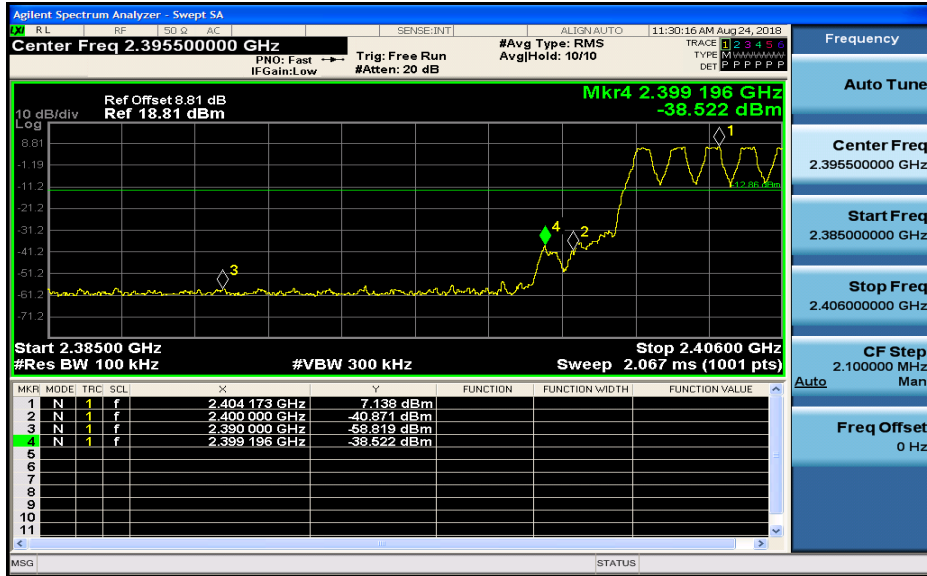

Band-edge for RF Conducted Emissions_DH5_2402_Hopping Off



Band-edge for RF Conducted Emissions_DH5_2480_Hopping On



Band-edge for RF Conducted Emissions_DH5_2480_Hopping Off



Band-edge for RF Conducted Emissions_2DH5_2402_Hopping On

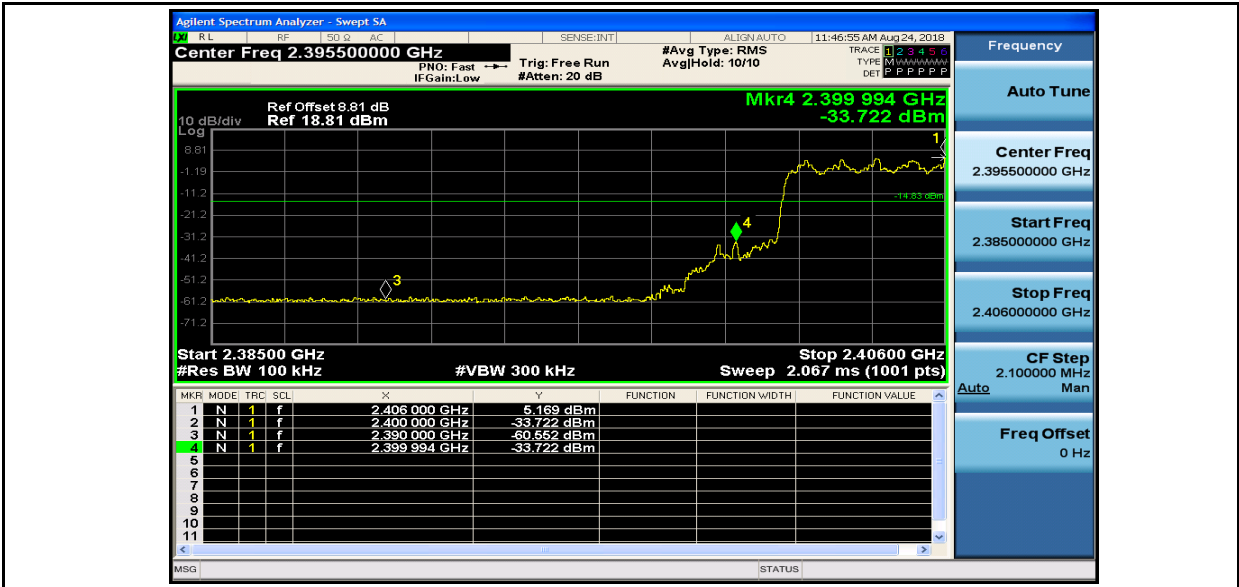

Band-edge for RF Conducted Emissions_2DH5_2402_Hopping Off



Band-edge for RF Conducted Emissions_2DH5_2480_Hopping On

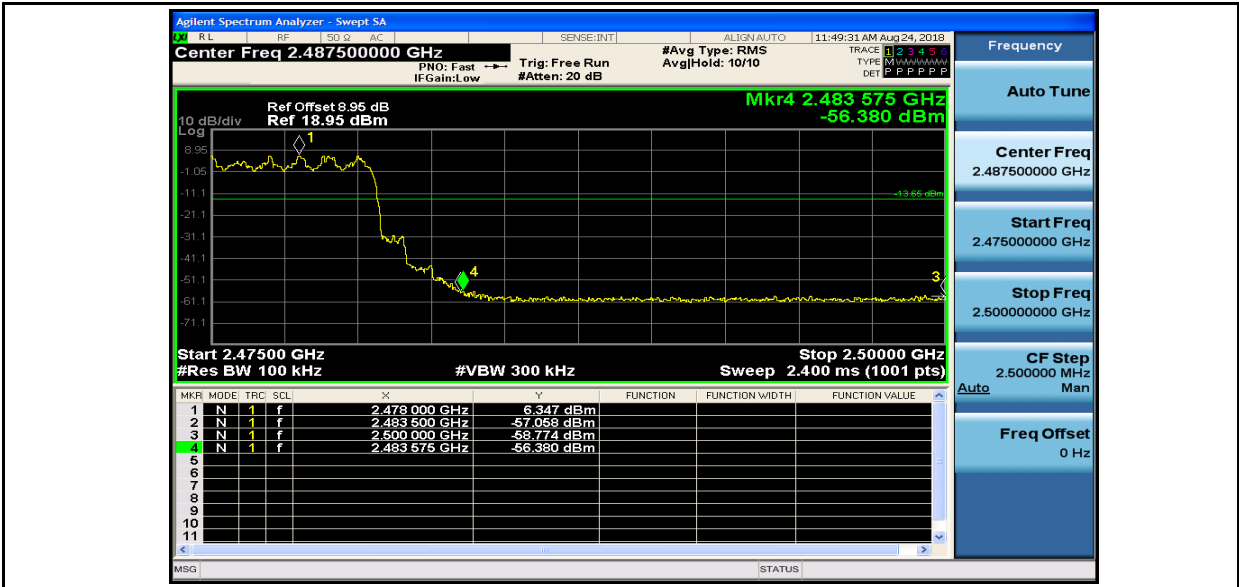

Band-edge for RF Conducted Emissions_2DH5_2480_Hopping Off



Band-edge for RF Conducted Emissions_3DH5_2402_Hopping On

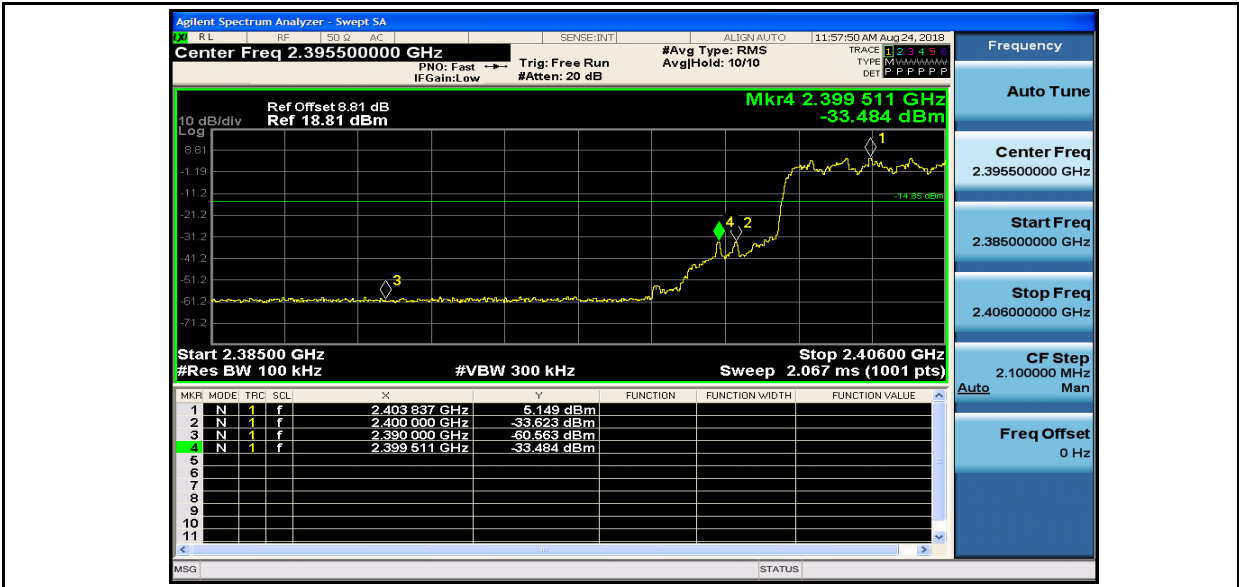

Band-edge for RF Conducted Emissions_3DH5_2402_Hopping Off



Band-edge for RF Conducted Emissions_3DH5_2480_Hopping On



Band-edge for RF Conducted Emissions_3DH5_2480_Hopping Off



8.RF Conducted Spurious Emissions

Test Mode	Test Channel	StartFre [MHz]	StopFre [MHz]	RBW [kHz]	VBW [kHz]	Pref[dBm]	Max. Level [dBm]	Limit [dBm]	Verdict
DH5	2402	30	10000	100	300	6.43	-47.27	<-13.57	PASS
DH5	2402	10000	26000	100	300	6.426	-43.499	<-13.574	PASS
DH5	2441	30	10000	100	300	7.72	-47.93	<-12.28	PASS
DH5	2441	10000	26000	100	300	7.724	-43.418	<-12.276	PASS
DH5	2480	30	10000	100	300	8.04	-48.76	<-11.96	PASS
DH5	2480	10000	26000	100	300	8.043	-44.184	<-11.957	PASS
2DH5	2402	30	10000	100	300	5.36	-47.55	<-14.64	PASS
2DH5	2402	10000	26000	100	300	5.361	-44.728	<-14.639	PASS
2DH5	2441	30	10000	100	300	5.78	-49.81	<-14.22	PASS
2DH5	2441	10000	26000	100	300	5.783	-43.914	<-14.217	PASS
2DH5	2480	30	10000	100	300	5.56	-51.80	<-14.45	PASS
2DH5	2480	10000	26000	100	300	5.555	-44.006	<-14.445	PASS
3DH5	2402	30	10000	100	300	5.78	-51.22	<-14.22	PASS
3DH5	2402	10000	26000	100	300	5.783	-43.825	<-14.217	PASS
3DH5	2441	30	10000	100	300	5.79	-51.85	<-14.21	PASS
3DH5	2441	10000	26000	100	300	5.787	-44.454	<-14.213	PASS
3DH5	2480	30	10000	100	300	5.93	-50.40	<-14.07	PASS
3DH5	2480	10000	26000	100	300	5.926	-44.241	<-14.074	PASS



RF Conducted Spurious Emissions_DH5_2402

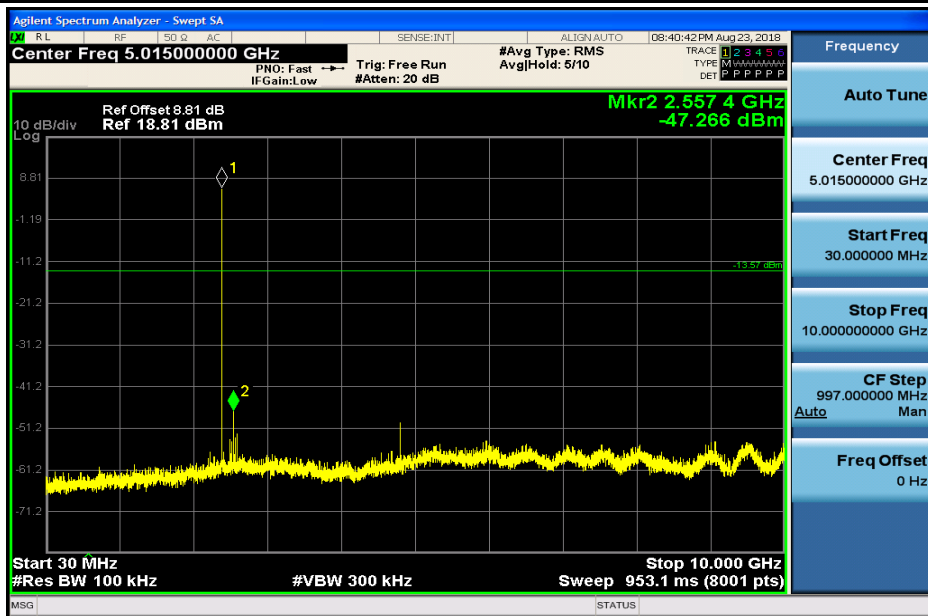

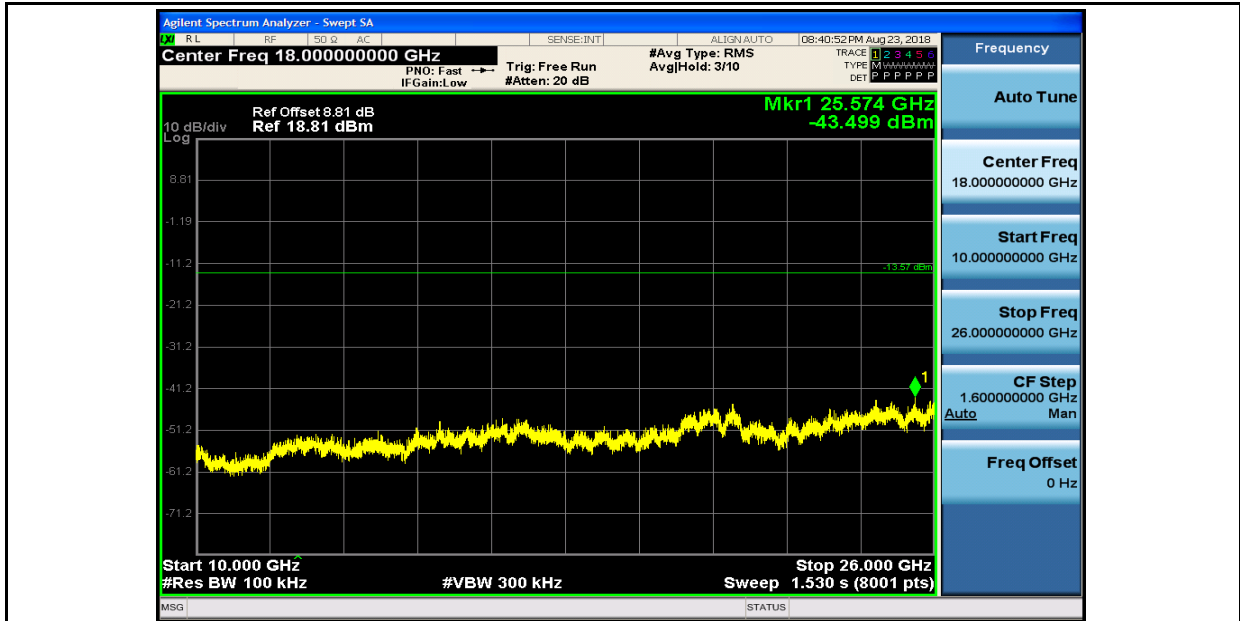

RF Conducted Spurious Emissions_DH5_2441



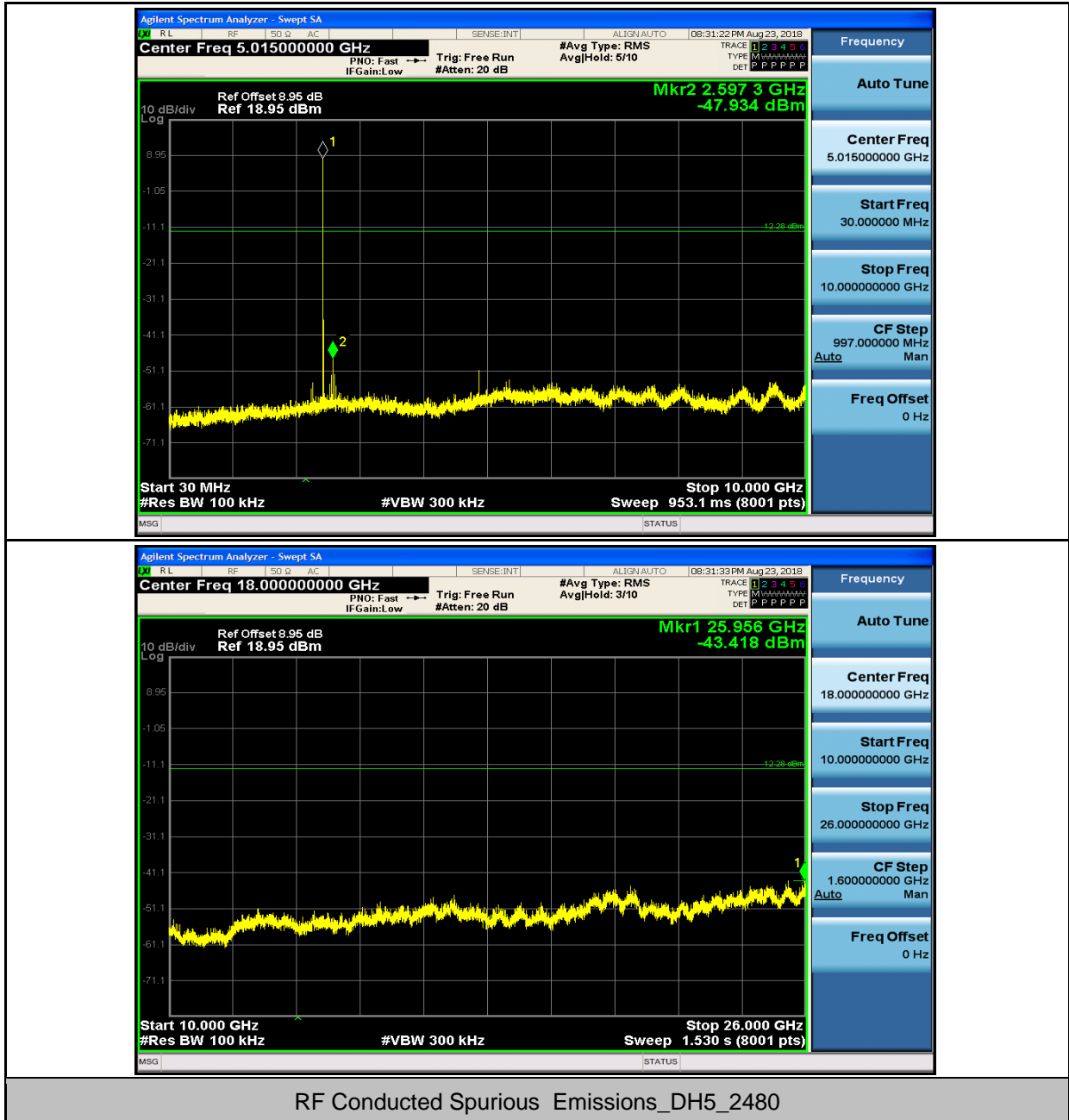

RF Conducted Spurious Emissions_DH5_2480

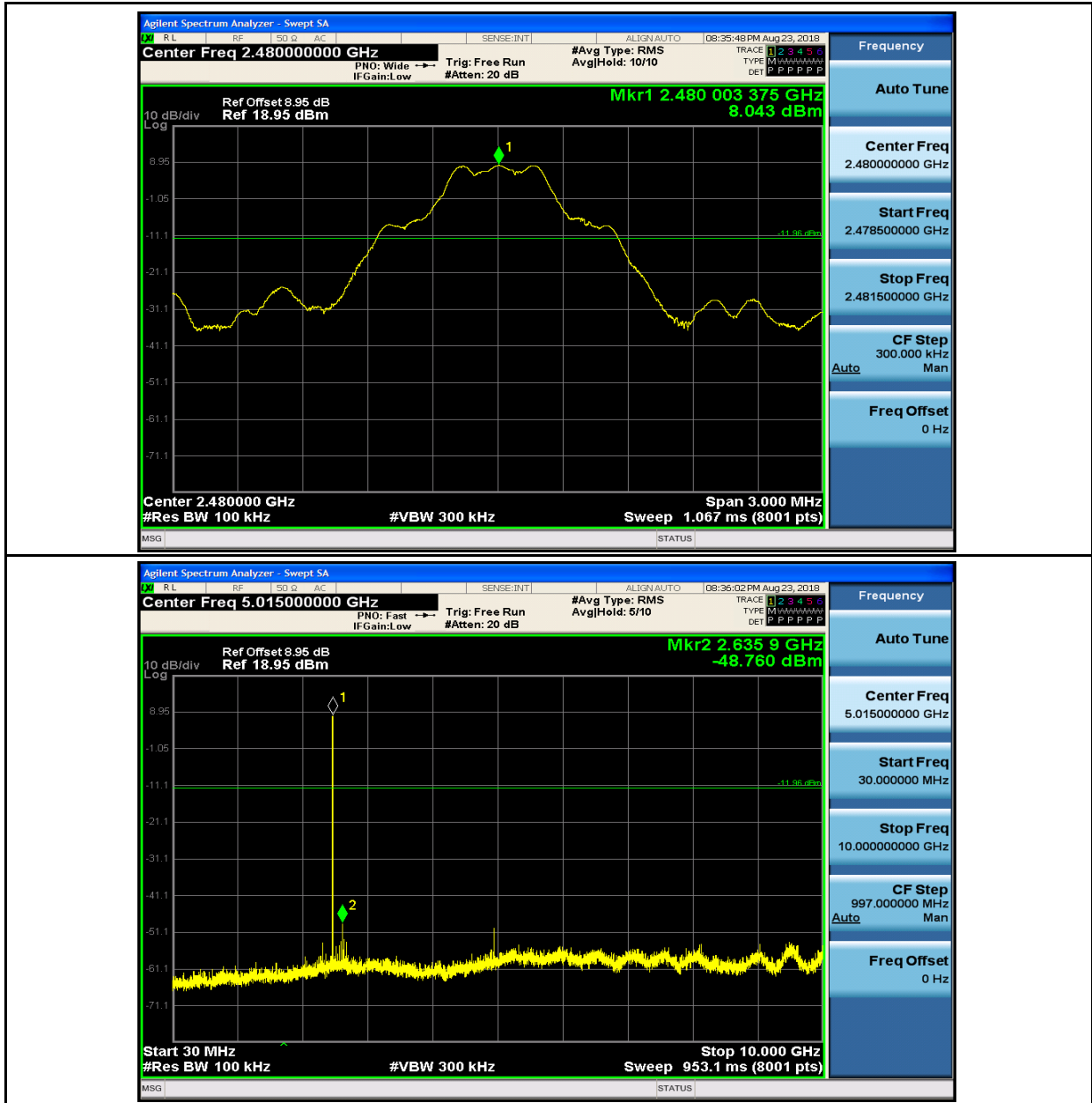

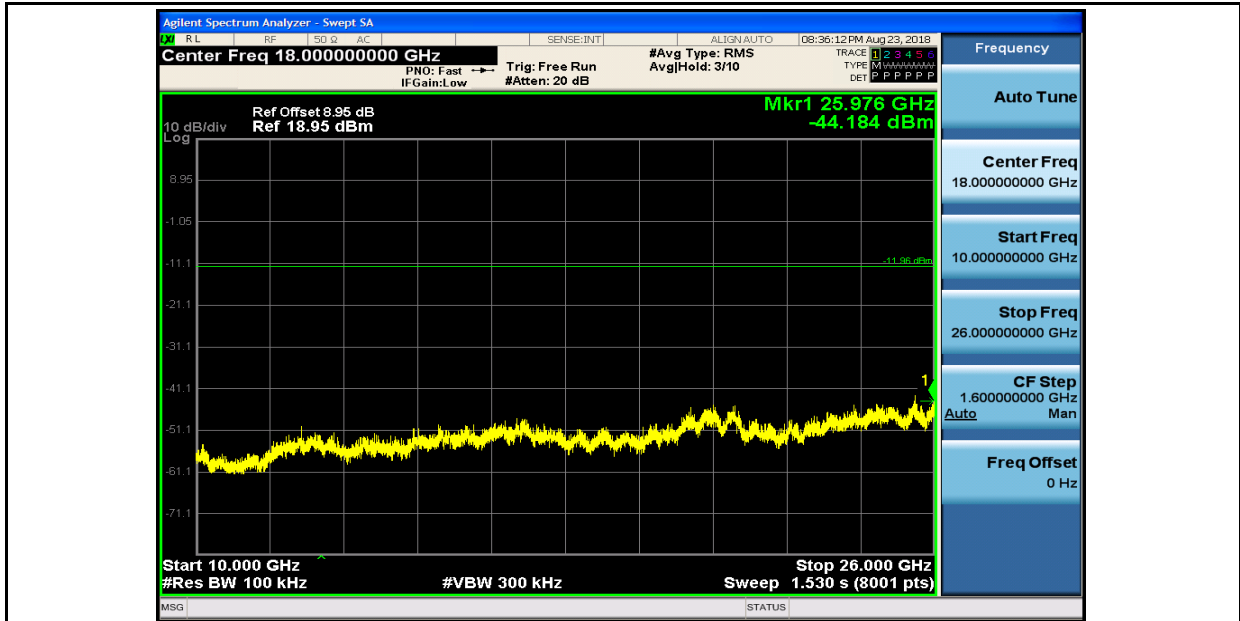

RF Conducted Spurious Emissions_2DH5_2402



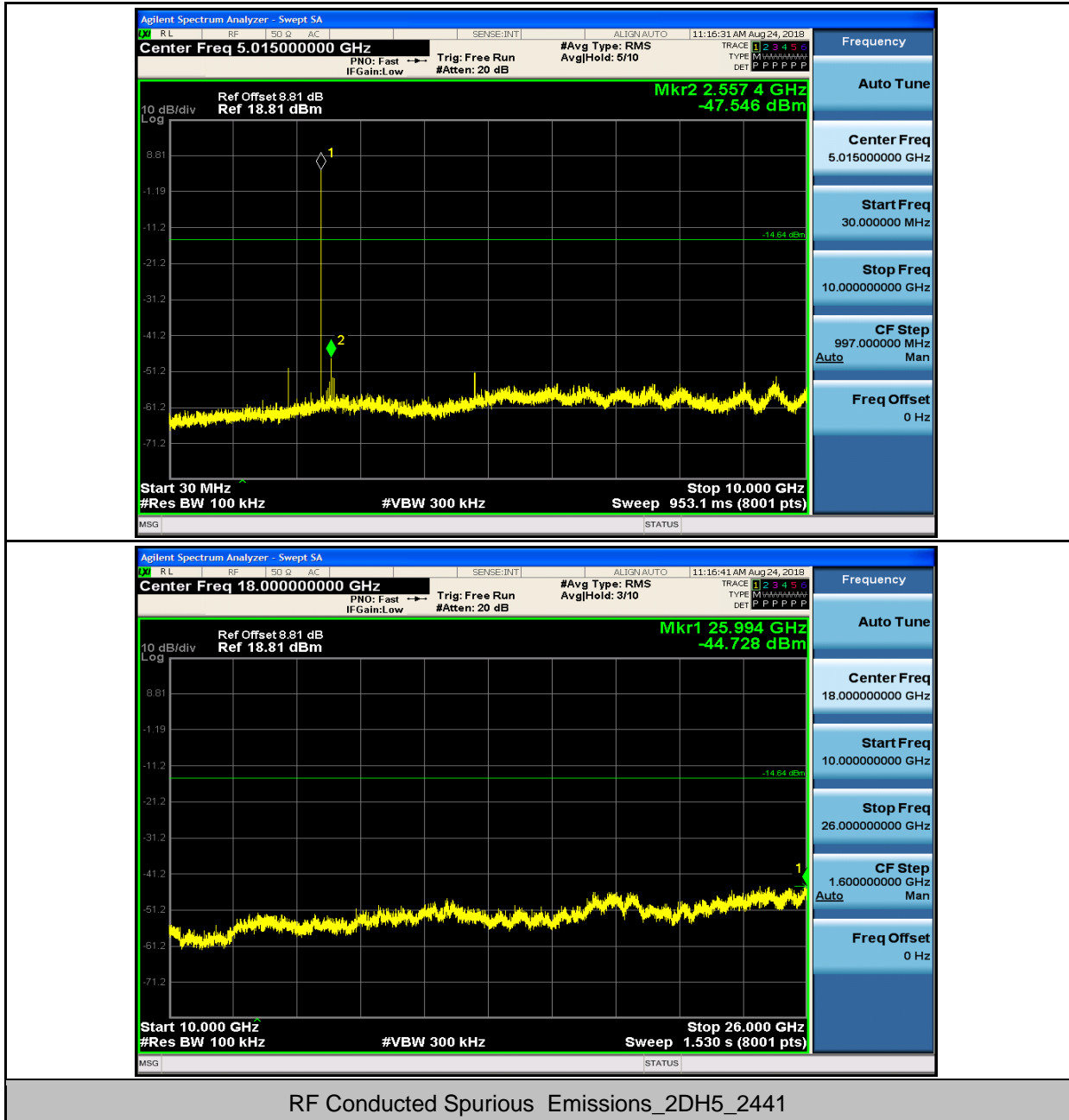

RF Conducted Spurious Emissions_2DH5_2441

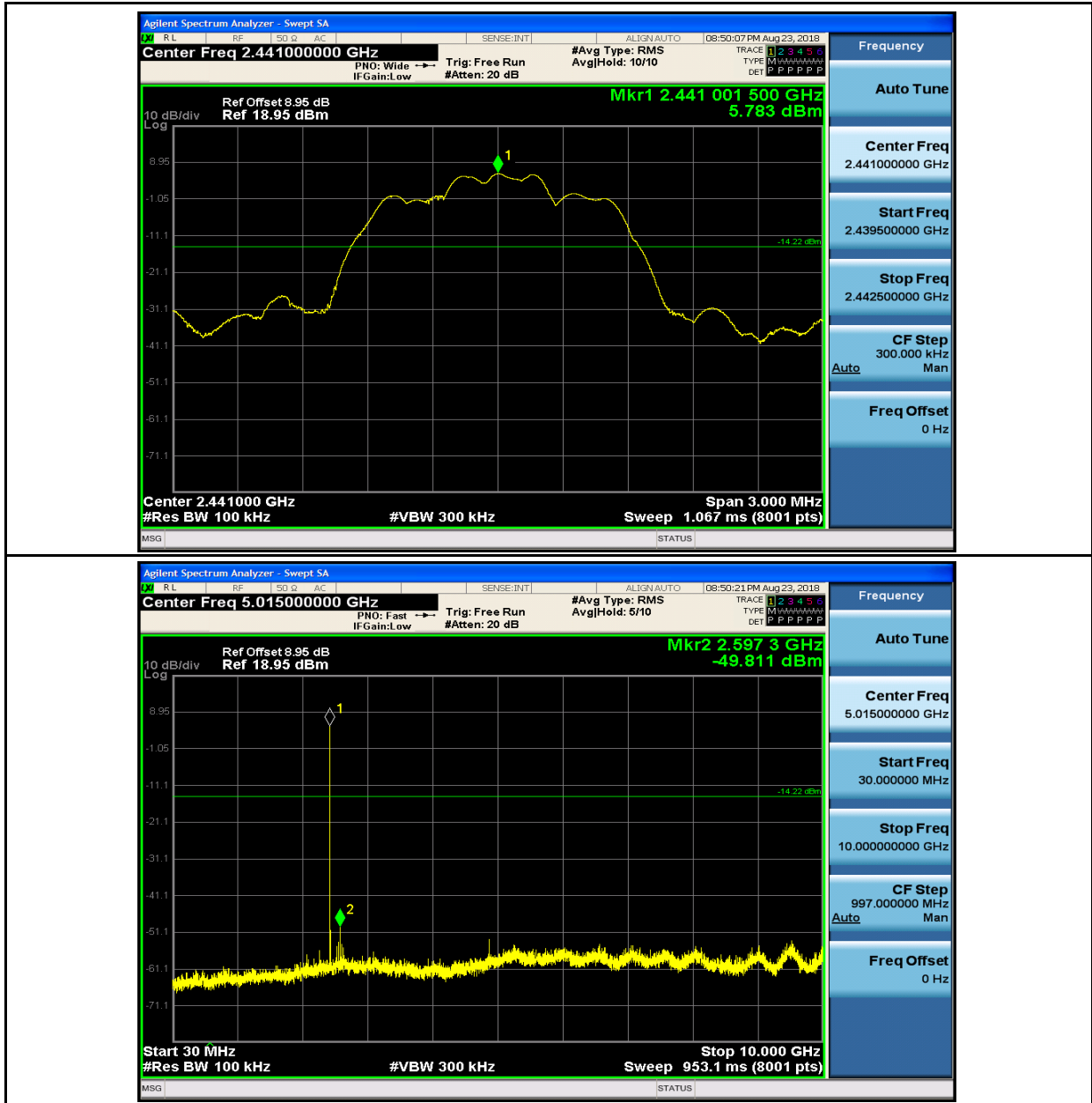

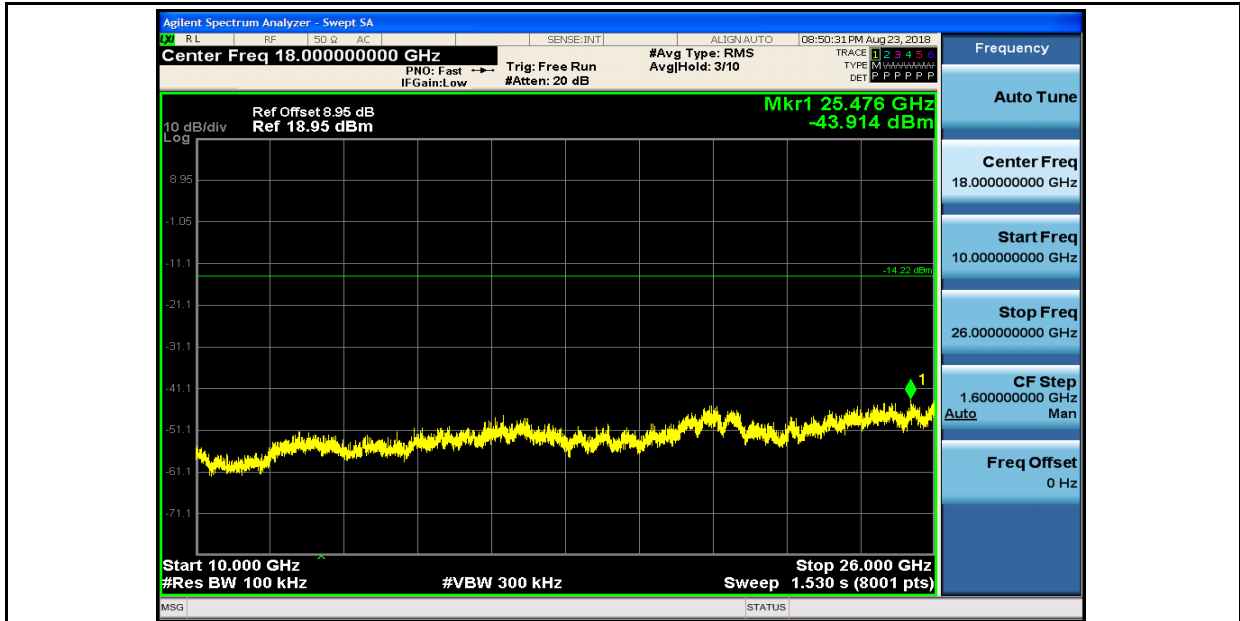

RF Conducted Spurious Emissions_2DH5_2480



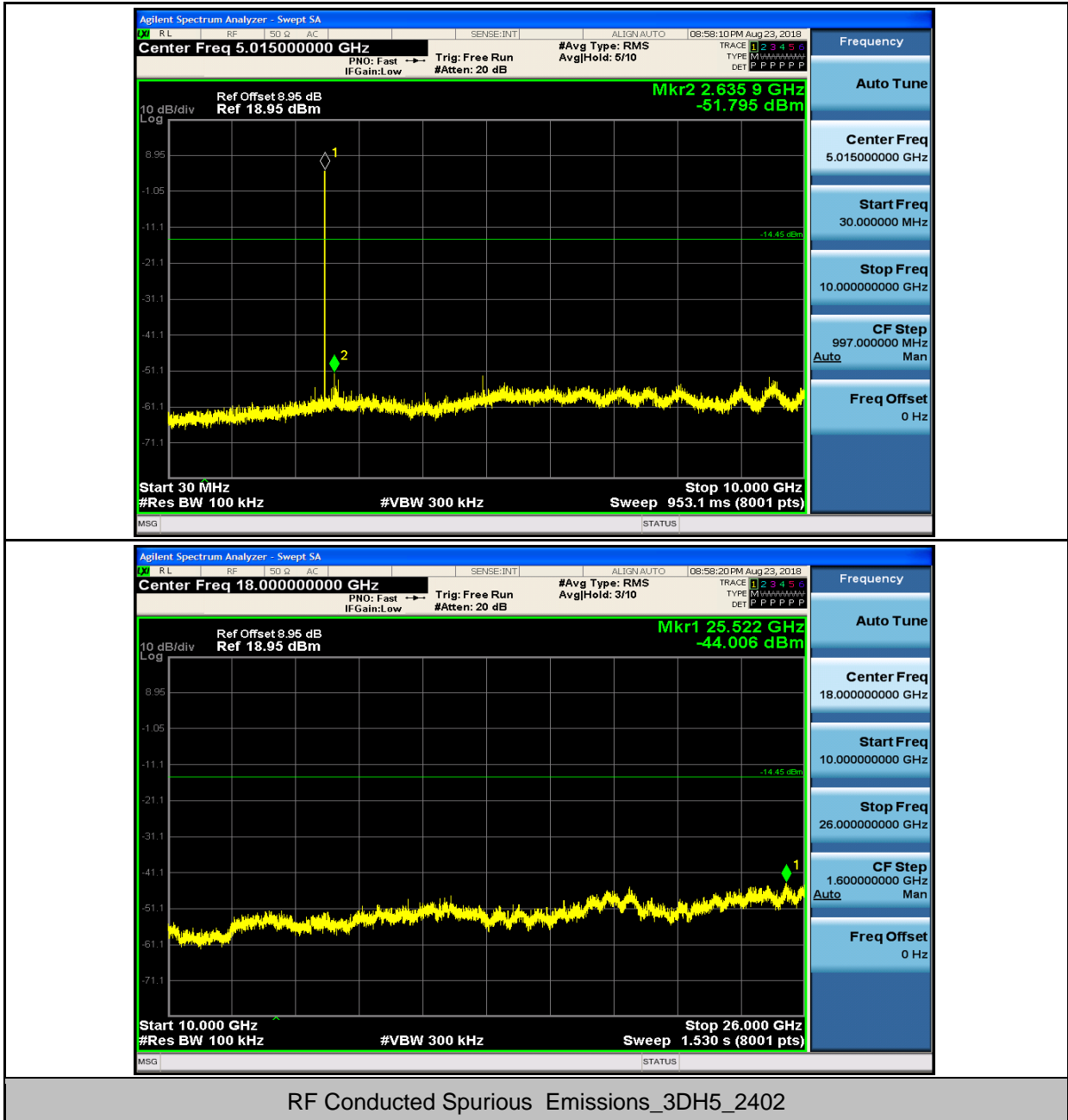

RF Conducted Spurious Emissions_3DH5_2402

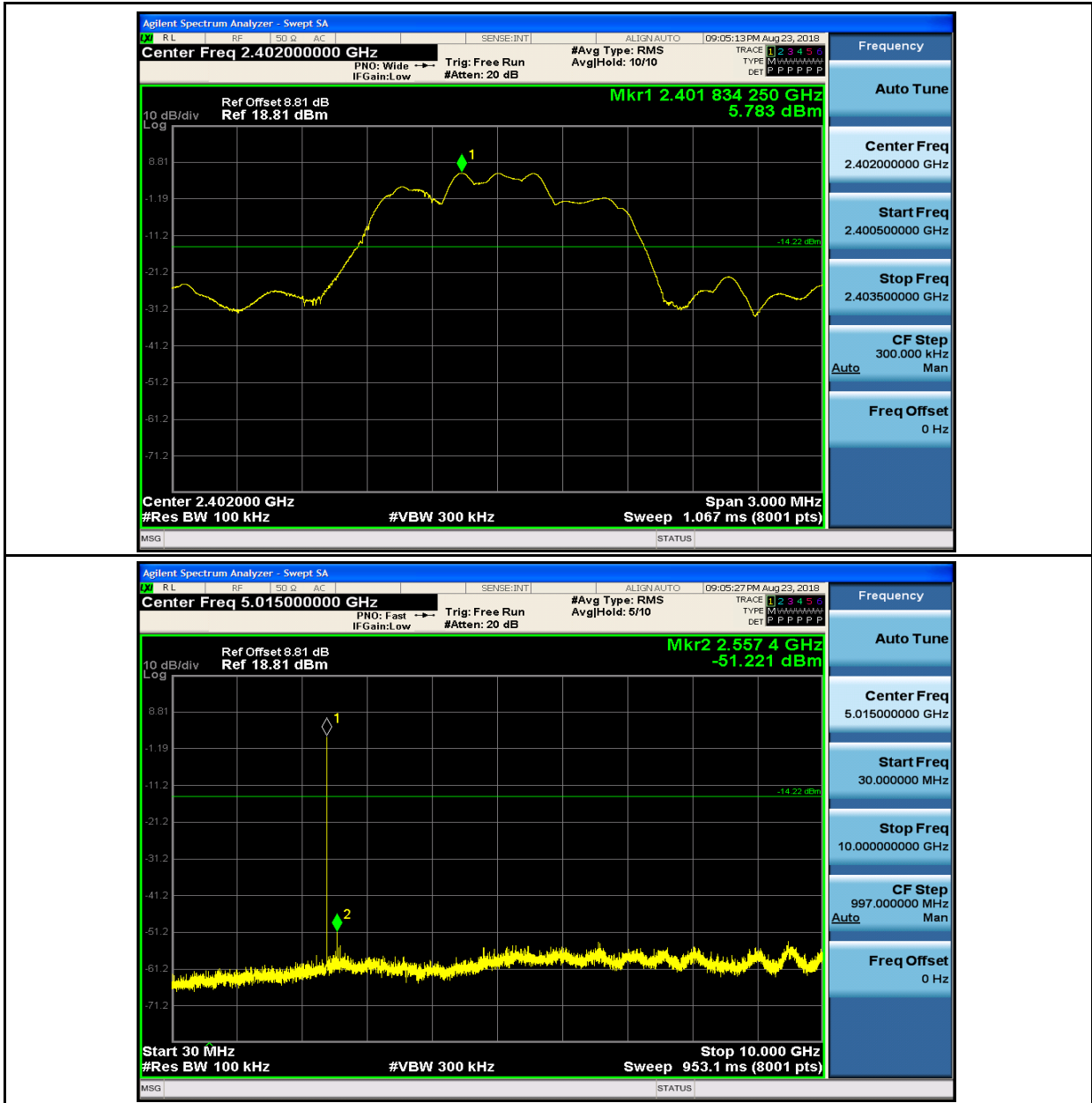

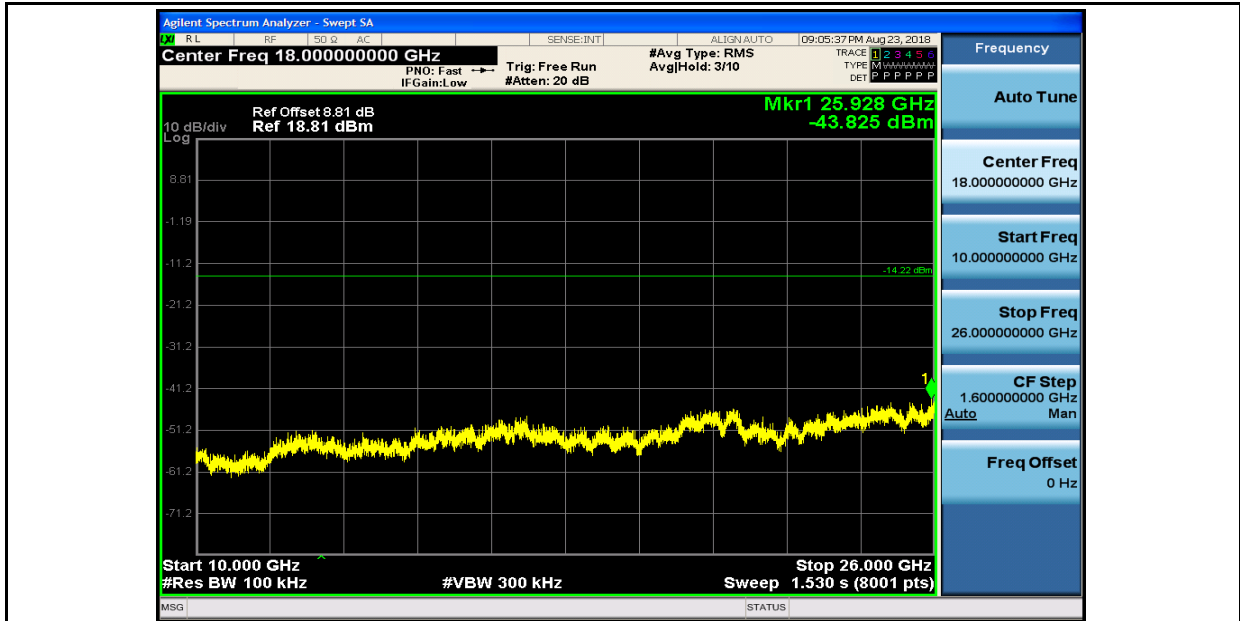

RF Conducted Spurious Emissions_3DH5_2441



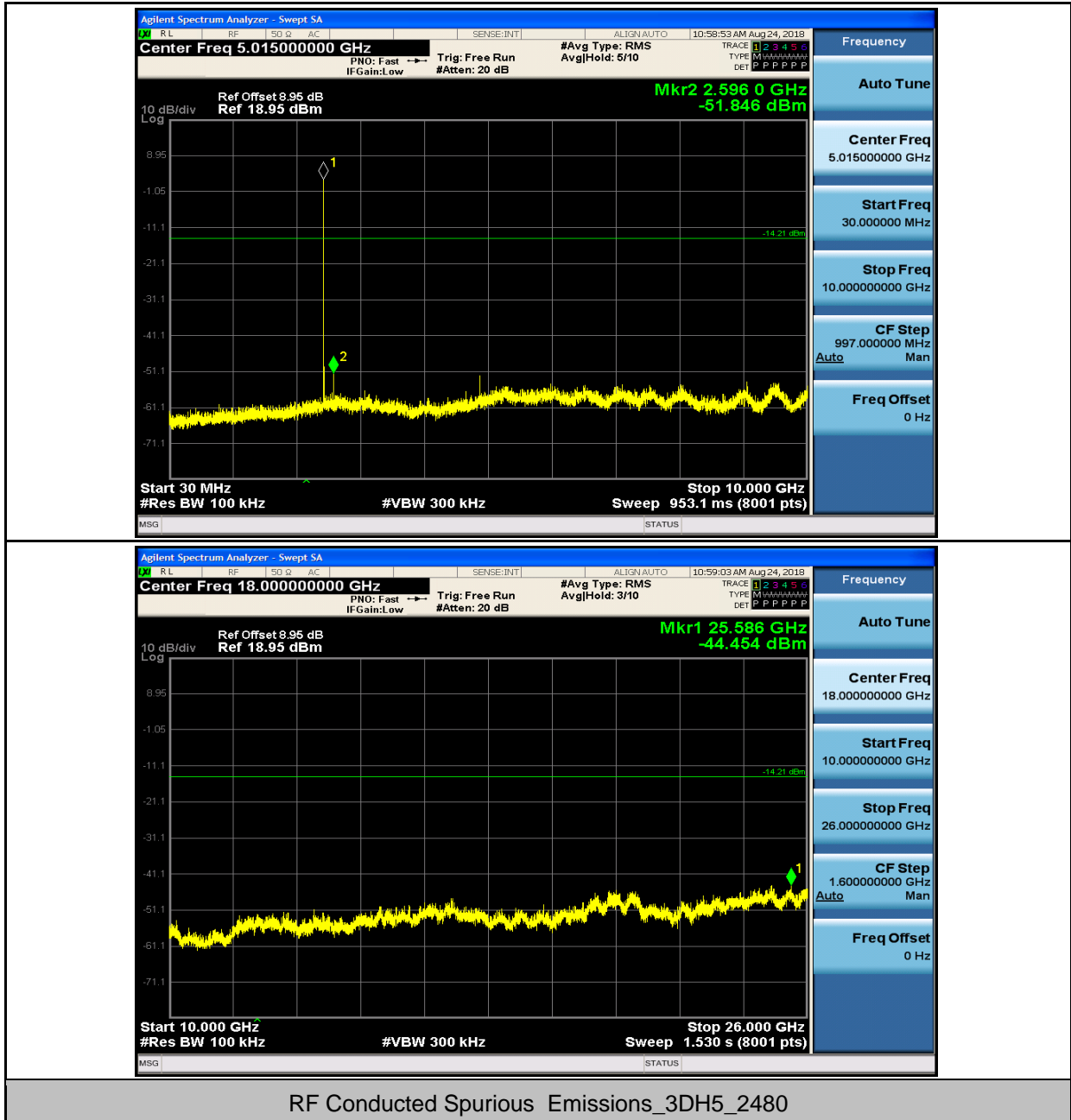

RF Conducted Spurious Emissions_3DH5_2480

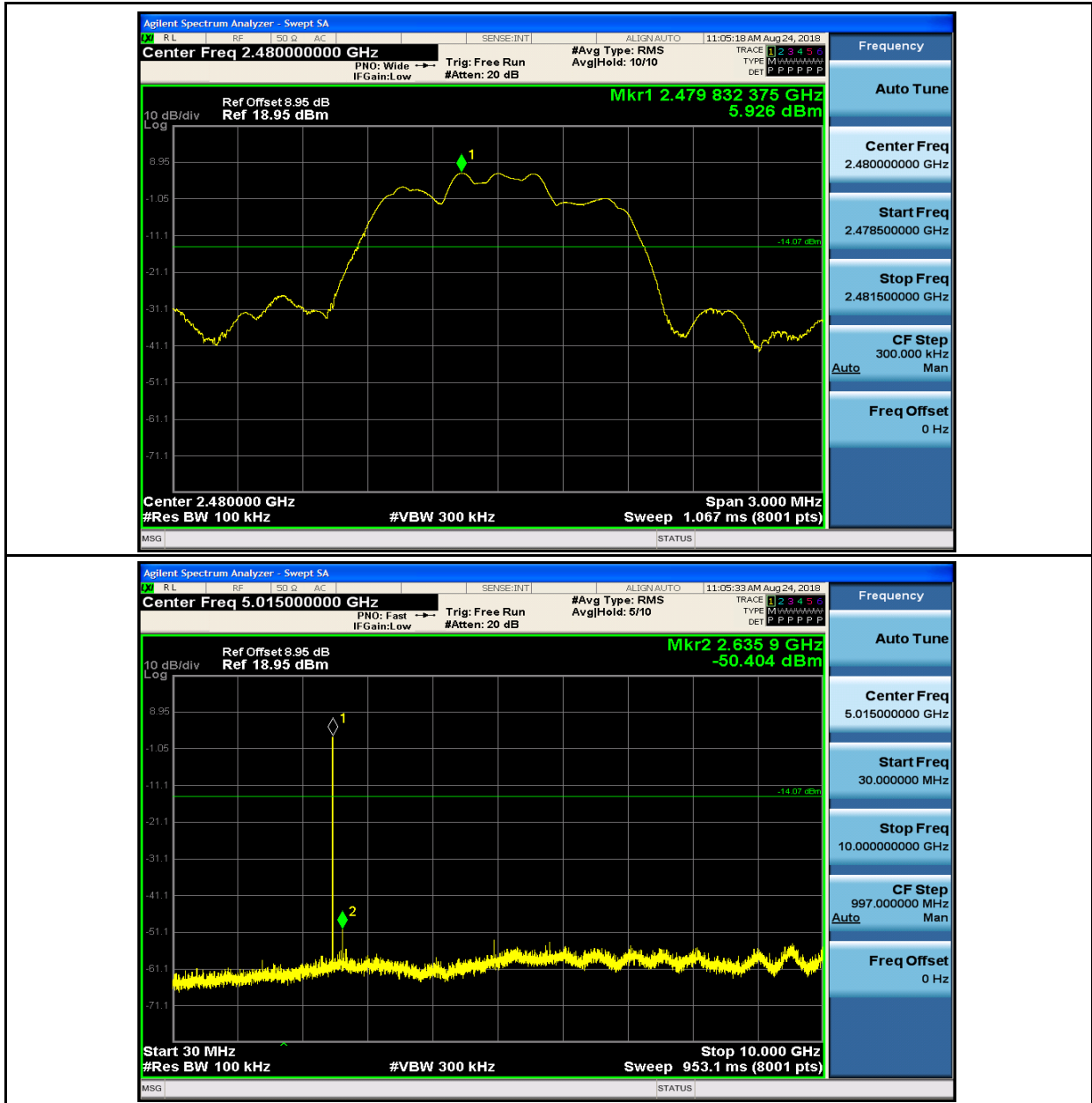

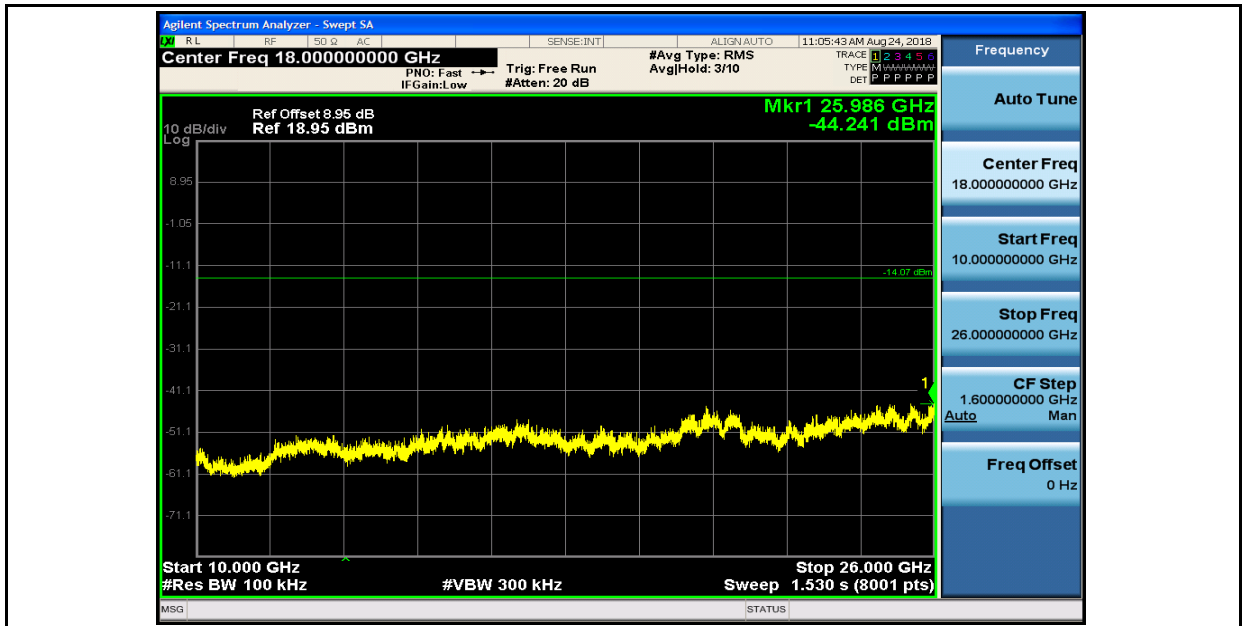

- End of the Report -