



FCC Test Report

Report No: FCS202011016W01

Issued for

Applicant:	Adam Hall GmbH
Address:	Adam-Hall-Str.1, Neu-Anspach, 61267, Germany
Product Name:	UHF In Ear Monitor System
Brand Name:	LD SYSTEMS
Model Name:	LDU5051IEM
Series Model:	N/A
FCC ID:	2AFF6-LDU5051IEM
<p>Issued By: Flux Compliance Service Laboratory Add: Room 105 Floor Bao hao Technology Building 1 NO.15 Gong ye West Road Hi-Tech Industrial, Song shan lake Dongguan Tel: 769-27280901 Fax:769-27280901 http://www.fcs-lab.com</p>	

TEST RESULT CERTIFICATION

Applicant's Name: Adam Hall GmbH
Address.....: Adam-Hall-Str.1, Neu-Anspach, 61267, Germany
Manufacture's Name: Adam Hall GmbH
Address.....: Adam-Hall-Str.1, Neu-Anspach, 61267, Germany

Product Description

Product Name: UHF In Ear Monitor System
Brand Name: LD SYSTEMS
Model Name.....: LDU5051IEM
Series Model: N/A
Test Standards: FCC Rules and Regulations Part 15 Subpart C section 15.236
Test Procedure: ANSI C63.10:2013

This device described above has been tested FCS, the test results show that the equipment under test (EUT) is in compliance with the FCC requirements. And it is applicable only to the tested sample identified in the report.

This report shall not be reproduced except in full, without the written approval of FCS, this document may be altered or revised by FCS, personal only, and shall be noted in the revision of the document..

Date of Test :

Date (s) of performance of tests : Nov 20, 2020 ~ Nov 30, 2020

Date of Issue : Nov 30, 2020

Test Result.....: Pass

Testing Engineer :

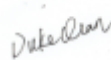

(Duke Qian)

Technical Manager :



(Jack Wang)

Authorized Signatory :



(Andy Yue)

Table of Contents

	Page
1. SUMMARY OF TEST RESULTS	5
1.1 TEST FACTORY	6
1.2 MEASUREMENT UNCERTAINTY	6
2. GENERAL INFORMATION	7
2.1 GENERAL DESCRIPTION OF THE EUT	7
2.2 DESCRIPTION OF THE TEST MODES	9
2.3 DESCRIPTION OF NECESSARY ACCESSORIES AND SUPPORT UNITS	10
2.4 EQUIPMENTS LIST	11
3 MAXIMUM RADIATED POWER	12
3.1 LIMIT	12
3.3 TEST SETUP	12
3.4 TEST RESULTS	12
4. OCCUPIED BANDWIDTH	13
4.1 LIMIT	13
4.2 TEST PROCEDURE	13
4.3 TEST SETUP	13
4.4 TEST RESULTS	14
5 NECESSARY BANDWITH	15
5.1 LIMIT	15
5.2 TEST PROCEDURE	15
5.3 TEST SETUP	15
6. TRANSMITTER UNWANTED EMISSIONS	17
6.1 LIMIT	17
5.2 TEST PROCEDURE	17
5.3 TEST SETUP	17
6.4 TEST RESULTS	18
7. FREQUENCY STABILITY	22
7.1 LIMIT	22
7.2 TEST PROCEDURE	22
7.3 TEST SETUP	22
7.4 TEST RESULTS	23

Table of Contents

	Page
8 CONDUCTED EMISSION MEASUREMENT	26
8.1 LIMIT	26
8.2 TEST PROCEDURE	26
8.3 TEST SETUP	27
8.4 TEST RESULTS	27

Revision History

Rev.	Issue Date	Effect Page	Contents
00	Nov 30, 2020	All	Initial Issue

1. SUMMARY OF TEST RESULTS

FCC Part 15 Subpart C section 15.236			
Standard Section	Test Item	Judgment	Remark
FCC Part 15.236(d)	Maximum Radiated Power	PASS	--
FCC Part 15.236(f)(2)	Occupied Bandwidth	PASS	--
FCC Part 15.236(g)	Necessary bandwidth	PASS	--
FCC Part 15.236(f)(3)	Frequency stability	PASS	--
FCC Part 15.236(g)	Emission within the band and outside this band	PASS	--
FCC Part 15.207	Conducted Emission	PASS	--

NOTE:

- (1) "N/A" denotes test is not applicable in this Test Report
- (2) All tests are according to ANSI C63.10:2013

1.1 TEST FACTORY

Company Name:	Flux Compliance Service Laboratory
Address:	Room 105 Floor Bao hao Technology Building 1 NO.15 Gong ye West Road Hi-Tech Industrial, Song shan lake Dongguan
Telephone:	+86-769-27280901
Fax:	+86-769-27280901
FCC Test Firm Registration Number: 514908 Designation number: CN0127 A2LA accreditation number: 5545.01	

1.2 MEASUREMENT UNCERTAINTY

The reported uncertainty of measurement $y \pm U$, where expended uncertainty U is based on a standard uncertainty multiplied by a coverage factor of $k=2$, providing a level of confidence of approximately **95 %**.

No.	Item	Uncertainty
1	RF output power, conducted	± 0.71 dB
2	Unwanted Emissions, conducted	± 2.98 dB
3	Conducted Emission (9KHz-150KHz)	± 4.13 dB
4	Conducted Emission (150KHz-30MHz)	± 4.74 dB
5	All emissions, radiated (<1G) 30MHz-1000MHz	± 3.2 dB
6	All emissions, radiated (1GHz -18GHz)	± 3.66 dB
7	All emissions, radiated (18GHz -40GHz)	± 4.31 dB

2. GENERAL INFORMATION

2.1 GENERAL DESCRIPTION OF THE EUT

Product Name	UHF In Ear Monitor System
Model Name	LD SYSTEMS
Series Model	LDU5051IEM
Channel List	Please refer to the Note 2.
Operation frequency	514MHz- 542MHz
Modulation Type	FM
Antenna Type	External Antenna
Antenna Gain (dBi)	1.0
Power Supply	DC 12V by adapter
Hardware version number	V1.0
Software version number	V1.0
Connecting I/O Port(s)	Please refer to the User's Manual

Note:

1. For a more detailed features description, please refer to the manufacturer's specifications or the User's Manual.

2. Channel List

Channel					
Channel	Frequency (MHz)	Channel	Frequency (MHz)	Channel	Frequency (MHz)
01	517.75				
02	523.75				
03	529.75				
04	535.75				
05	541.75				

Ant.	Antenna Brand	Antenna Model Name	Antenna Type	Connector	Gain (dBi)	NOTE
1	NA	Ysis	External Antenna	N/A	1.0	Antenna

2.2 DESCRIPTION OF THE TEST MODES

To investigate the maximum EMI emission characteristics generates from EUT, the test system was pre-scanning tested base on the consideration of following EUT operation mode or test configuration mode which possible have effect on EMI emission level. Each of these EUT operation mode(s) or test configuration mode(s) mentioned above was evaluated respectively.

Test software:FCC tools

The test software was used to control EUT work in continuous TX mode, and select test channel, Wireless mode as below table, the following operating modes were applied for the related test items. All test modes were tested, only the result of the worst case was recorded in the report.

Tested mode, channel , information		
Mode	Channel	Frequency (MHz)
Channel	CH 01	517.75
	CH 03	529.75
	CH 05	541.75

2.3 DESCRIPTION OF NECESSARY ACCESSORIES AND SUPPORT UNITS

The EUT has been tested as an independent unit together with other necessary accessories or support units. The following support units or accessories were used to form a representative test configuration during the tests.

Necessary accessories

Item	Equipment	Mfr/Brand	Model/Type No.	Serial No.	Note

Support units

Item	Equipment	Mfr/Brand	Model/Type No.	Serial No.	Note

Note:

- (1) The support equipment was authorized by Declaration of Confirmation.
- (2) For detachable type I/O cable should be specified the length in cm in 『Length』 column.
- (3) “YES” is means “shielded” “with core”; “NO” is means “unshielded” “without core”.

2.4 EQUIPMENTS LIST

Radiation Test equipment

Kind of Equipment	Manufacturer	Type No.	Company No.	Last calibration	Calibrated until
EMI Test Receiver	R&S	ESRP 3	FCS-E001	2020. 06.26	2021. 06.25
Signal Analyzer	R&S	FSV40-N	FCS-E012	2020.06.05	2021.06.04
Active loop Antenna	ZHINAN	ZN30900C	FCS-E013	2020.08.09	2021.08.10
Bilog Antenna	SCHWARZBECK	VULB 9168	FCS-E002	2020.08.26	2021.08.25
Horn Antenna	SCHWARZBECK	BBHA 9120D	FCS-E003	2020.08.26	2021.08.25
SHF-EHF Horn Antenna (18G-40GHz)	A-INFO	LB-180400-KF	FCS-E018	2020.06.26	2021.06.25
Pre-Amplifier(0.1M-3G Hz)	EMCI	EM330N	FCS-E004	2020.06.26	2021.06.25
Pre-Amplifier (1G-18GHz)	N/A	TSAMP-0518SE	FCS-E014	2020.06.03	2021.06.02
Pre-Amplifier (18G-40GHz)	TERA-MW	TRLA-0400	FCS-E019	2020.08.08	2021.08.07
Temperature & Humidity	HTC-1	victor	FCS-E005	2020.08.26	2021.08.25

Conduction Test equipment

Kind of Equipment	Manufacturer	Type No.	Company No.	Last calibration	Calibrated until
EMI Test Receiver	R&S	ESPI	FCS-E020	2020.06.03	2021.06.02
LISN	R&S	ENV216	FCS-E007	2020.08.08	2021.08.07
LISN	ETS	3810/2NM	FCS-E009	2020.06.03	2021.06.02
Temperature & Humidity	HTC-1	victor	FCS-E008	2020.08.08	2021.08.07

RF Connected Test

Kind of Equipment	Manufacturer	Type No.	Company No.	Last calibration	Calibrated until
MXA SIGNAL Analyzer	Keysight	N9020B	FCS-E015	2020.06.03	2021.06.02
Spectrum Analyzer	Agilent	E4447A	MY50180039	2020.08.08	2021.08.07
Spectrum Analyzer	R&S	FSV-40	101499	2020.08.26	2021.08.25
Signal generator	Agilent	N5182A	FCS-E020	2020.08.26	2021.08.25
Audio analyzer	R&S	UPL	FCS-E021	2020.08.26	2021.08.25

3 MAXIMUM RADIATED POWER

3.1 LIMIT

Refer to FCC 15.236(d)

In the bands allocated and assigned for broadcast television and in the 600 MHz service band: 50 mW EIRP; In the 600 MHz guard bands including the duplex gap: 20 mW EIRP

3.2 TEST PROCEDURE

A · Connect each EUT's antenna output to power sensor by RF cable and attenuator

3.3 TEST SETUP



3.4 TEST RESULTS

Test mode	Channel	Frequency (MHz)	Peak Output Power (dBm)	Antenna Gain (dBi)	EIRP (dBm)	Limit(dBm)	Verdict
Channel	01	517.75	6.209	1	7.209	17dBm	PASS
	03	529.75	6.125	1	7.125		
	05	541.75	6.211	1	7.211		

4. OCCUPIED BANDWIDTH

4.1 LIMIT

One or more adjacent 25 kHz segments within the assignable frequencies may be combined to form a channel whose maximum bandwidth shall not exceed 200 kHz. The operating bandwidth shall not exceed 200 kHz

4.2 TEST PROCEDURE

Parameter	Setting
Detector	Peak/AV
Sweep time	Auto
Resolution bandwidth	1 % to 5 % of the occupied bandwidth
Video bandwidth:	3 x resolution bandwidth
Span:	2 x emission bandwidth
Trace mode:	Max. hold
Analyzer function:	99% power occupied bandwidth function
EUT:	Modulated signal with max. frequency deviation

4.3 TEST SETUP

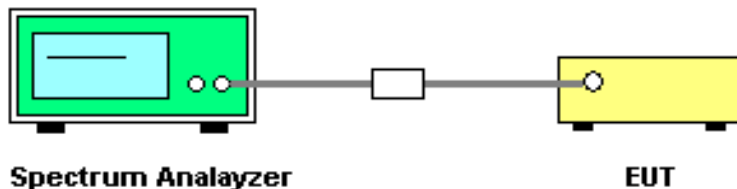

4.4 TEST RESULTS

Test mode	Channel	Frequency (MHz)	99% Bandwidth (KHz)	Limit(KHz)	Verdict
Channel	Low CH	517.75	168.75KHz	200	PASS
	Middle CH	529.75	167.55KHz		
	High CH	541.75	169.54KHz		

Channel

Low CH

Middle CH

High CH

5 NECESSARY BANDWIDTH

5.1 LIMIT

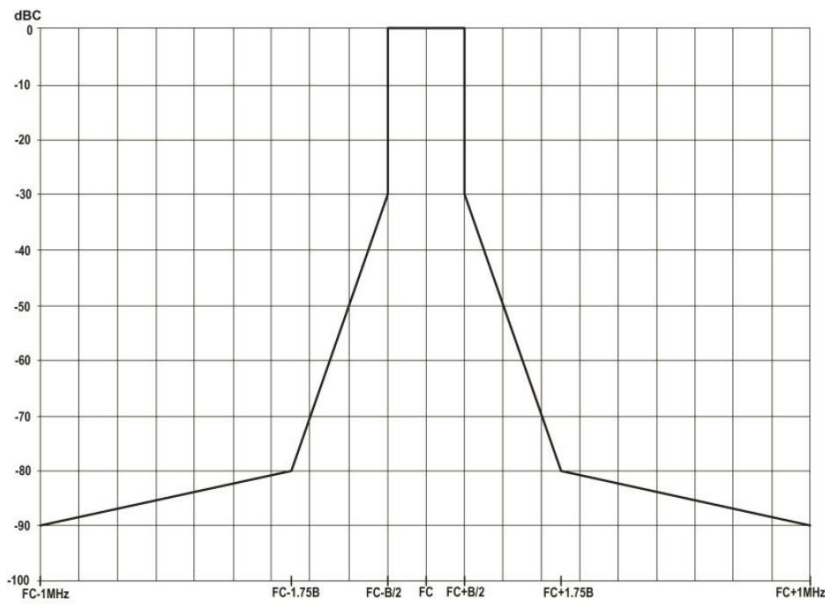

5.2 TEST PROCEDURE

EN300422-1 V1.4.2 Clause 8.3.

5.3 TEST SETUP

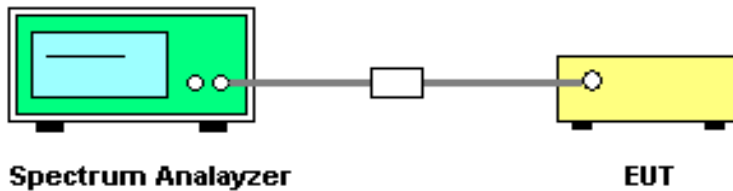

5.4 TEST RESULT

Emission Mask
Channel
Low CH

Middle CH

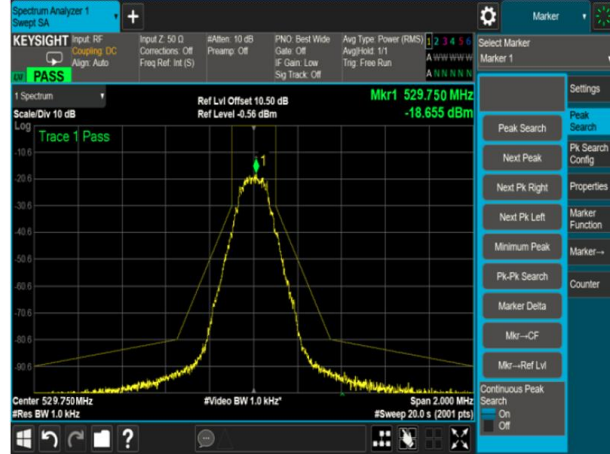
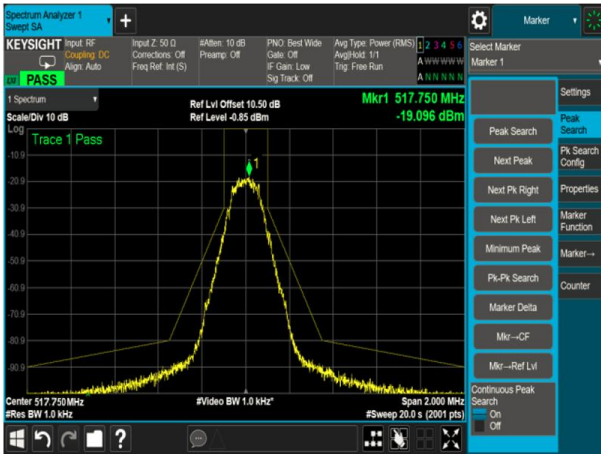

High CH

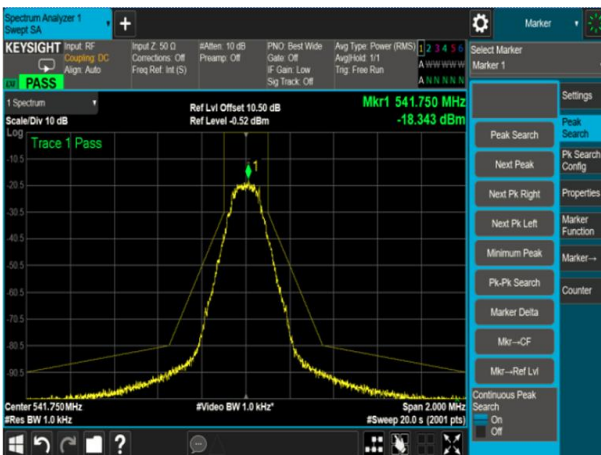

6. TRANSMITTER UNWANTED EMISSIONS

6.1 LIMIT

Spurious emissions are emissions outside the frequency range(s) of the equipment. The power of the spurious emissions shall not exceed the limits of table as below:

State	Frequency		
	47MHz to 74MHz, 87.5MHz to 137MHz 174MHz to 230MHz, 470MHz to 862MHz	Other Frequencies below 1000MHz	Frequencies above 1000MHz
Operation	4nW	250nW	1uW
Standby	2nW	2nW	20nW

5.2 TEST PROCEDURE

1. The transmitter output was connected to the spectrum analyzer through an attenuator. Set spectrum analyzer start 2400MHz to 2483.5MHz with 100 KHz RBW and 300 KHz VBW
2. Please refer to ETSI EN 300 422-1 V1.4.2 (2011-08) clause 6.1 for the test conditions.
3. Please refer to ETSI EN 300 422-1 V1.4.2 (2011-08) clause 8.4.2 for the measurement method.

5.3 TEST SETUP

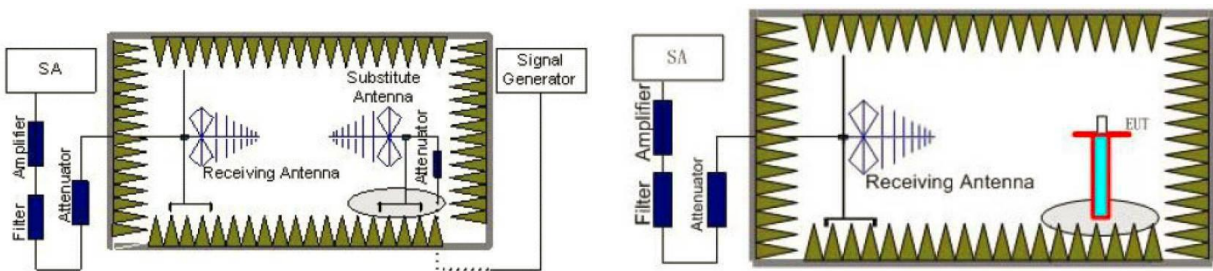

6.4 TEST RESULTS

CHANNEL -LOW CH-30MHZ-1000MHZ

Vertical

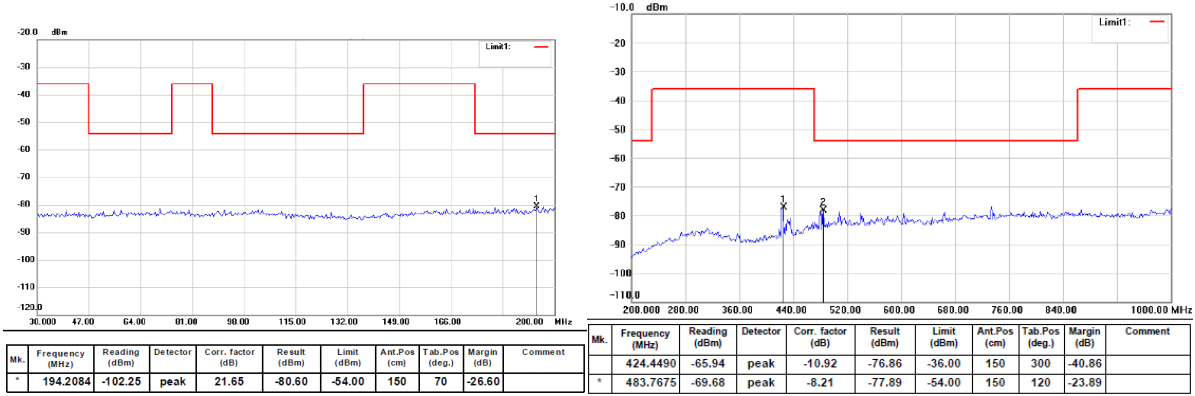

Horizontal

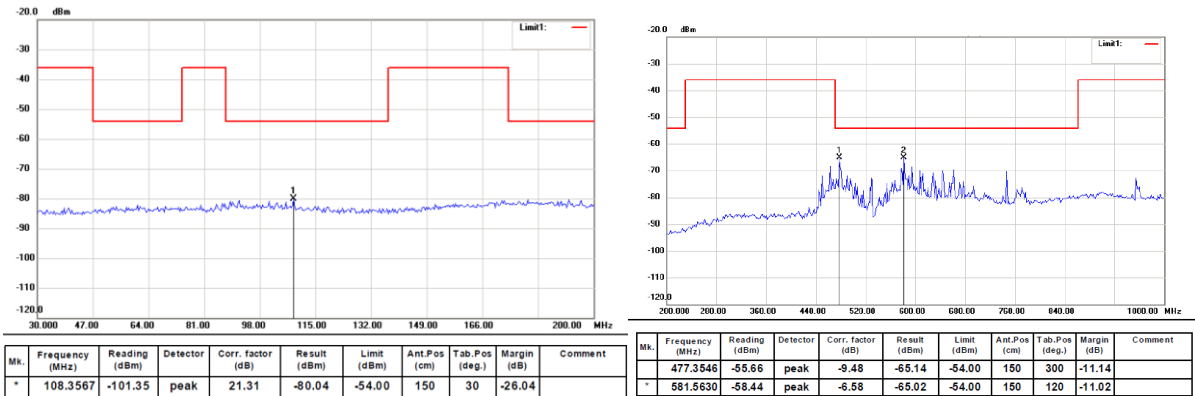

Note :

1. Result = Reading + Corrected Factor
2. The fundamental wave filtered out during the test.

CHNNEL –MIDDLE CH–30MHZ-1000MHZ

Vertical

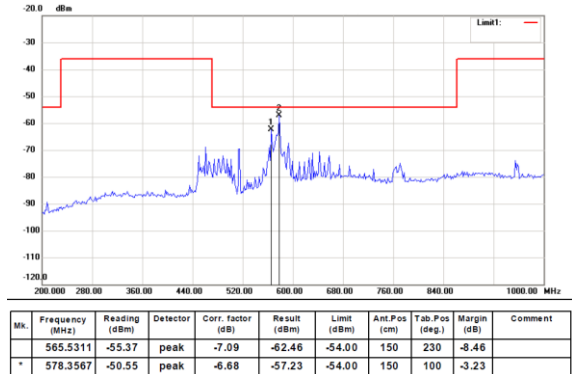
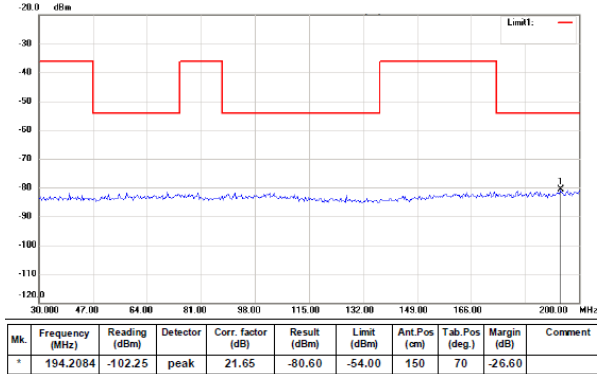

Horizontal

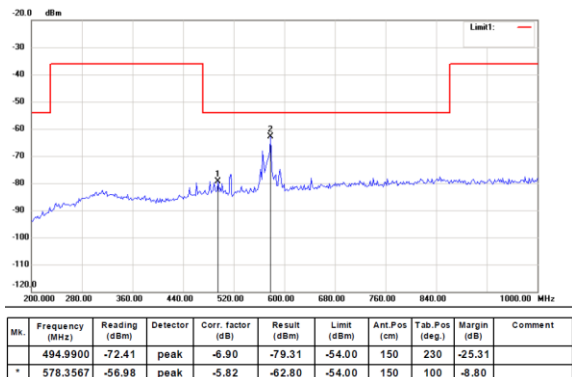
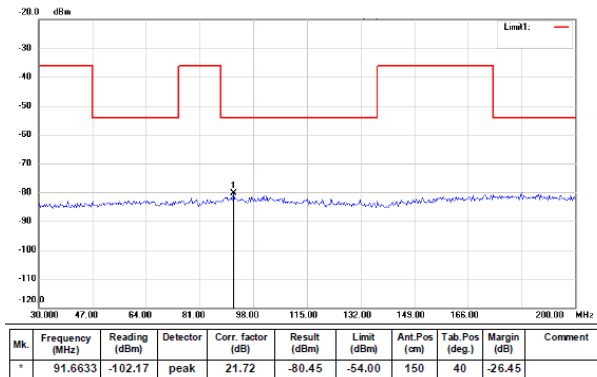

Note :

1. Result = Reading + Corrected Factor
2. The fundamental wave filtered out during the test.

CHNNEL -HIGH CH-30MHZ-1000MHZ

Vertical

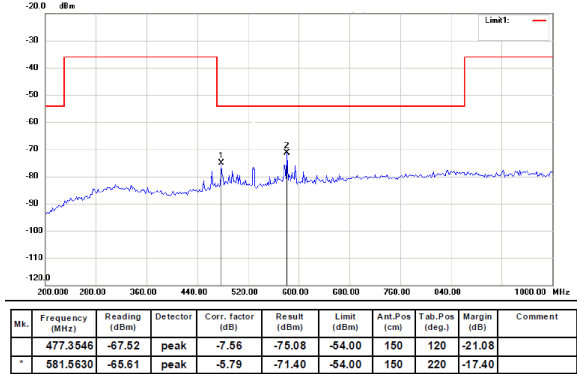
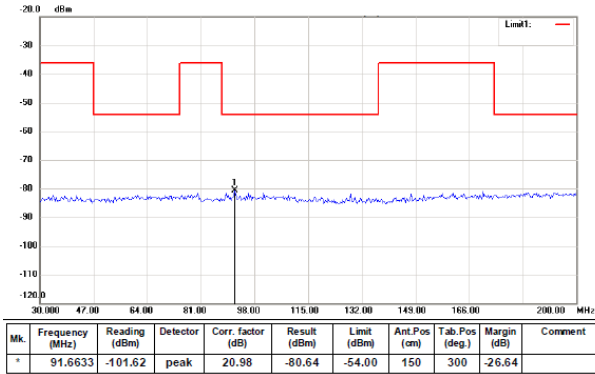

Horizontal

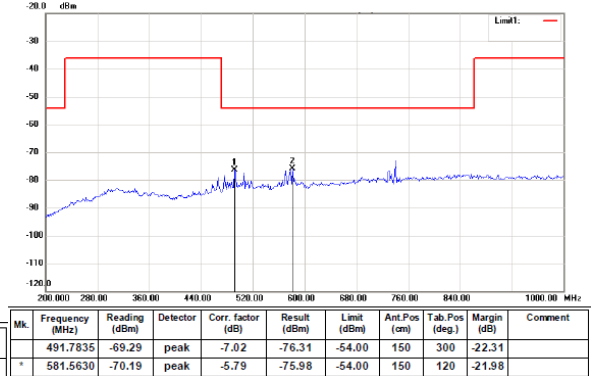
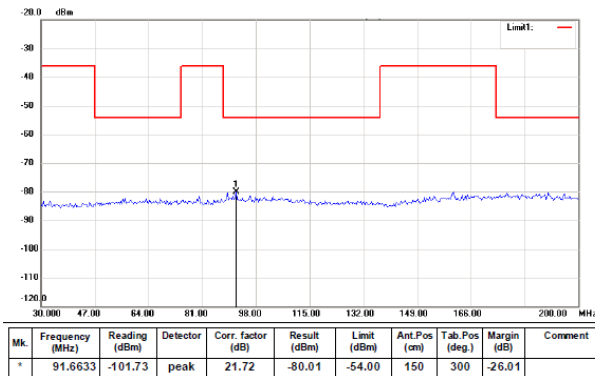

Note :

1. Result = Reading + Corrected Factor
2. The fundamental wave filtered out during the test.

CHANNEL 1GHZ-6GHZ

Test Channel (MHz)	Frequency (MHz)	Ant. Pol. (H/V)	SG Reading (dBm)	Cable Loss (dB)	Substitute Antenna Gain (dBi)	EIRP (dBm)	Limit (dBm)	Margin (dB)
517.750	3906.00	H	-56.01	4.85	11.66	-49.19	-30.00	-19.19
	5022.00	H	-54.16	5.54	12.67	-47.03	-30.00	-17.03
	5580.00	H	-54.73	5.85	13.15	-47.44	-30.00	-17.44
	3906.00	V	-54.86	3.71	9.37	-49.19	-30.00	-19.19
	5022.00	V	-54.29	4.23	11.49	-47.03	-30.00	-17.03
	5580.00	V	-55.36	4.81	12.74	-47.44	-30.00	-17.44
529.750	3906.00	H	-55.18	3.77	9.76	-49.19	-30.00	-19.19
	5022.00	H	-54.30	5.35	12.62	-47.03	-30.00	-17.03
	5580.00	H	-54.65	5.92	13.14	-47.44	-30.00	-17.44
	3906.00	V	-56.45	4.19	11.45	-49.19	-30.00	-19.19
	5022.00	V	-54.10	6.02	13.09	-47.03	-30.00	-17.03
	5580.00	V	-53.52	6.32	12.40	-47.44	-30.00	-17.44
541.750	3906.00	H	-56.45	4.27	11.53	-49.19	-30.00	-19.19
	5022.00	H	-54.64	5.09	12.70	-47.03	-30.00	-17.03
	5580.00	H	-53.16	6.44	12.16	-47.44	-30.00	-17.44
	3906.00	V	-57.05	4.71	12.58	-49.19	-30.00	-19.19
	5022.00	V	-54.14	5.47	12.59	-47.03	-30.00	-17.03
	5580.00	V	-53.16	6.44	12.16	-47.44	-30.00	-17.44

7. FREQUENCY STABILITY

7.1 LIMIT

The frequency tolerance of the carrier signal shall be maintained within $\pm 0.005\%$ of the operating frequency over a temperature variation of -20 degrees to $+50$ degrees C at normal supply voltage, and for a variation in the primary supply voltage from 85% to 115% of the rated supply voltage at a temperature of 20 degrees C

7.2 TEST PROCEDURE

a. The EUT was connected to an external DC power supply and the RF output was connected to a frequency counter via feed through attenuators. The EUT was placed inside the temperature chamber. The DC leads and the RF output cable, exited the chamber through an opening made for that purpose.

After the temperature stabilized the frequency output was recorded from the counter. An external variable DC power supply was connected to the battery terminals of the equipment under test.

b. For hand carried, battery powered equipment primary supply voltage was reduced to the battery operating end point as specified by the manufacturer. The output frequency was recorded for each battery voltage.

7.3 TEST SETUP

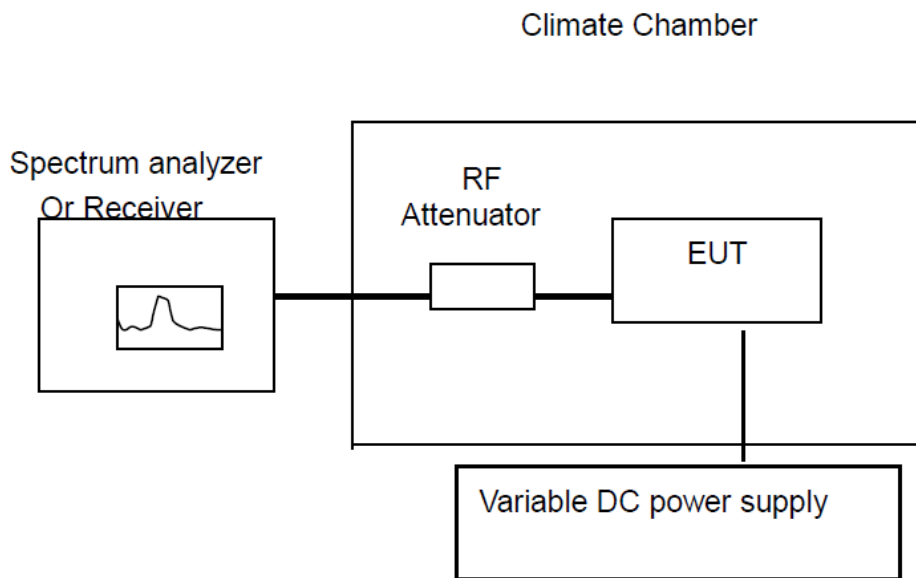

7.4 TEST RESULTS

- (1) Frequency stability versus input voltage (Supply Nominal voltage is DC 12V)
- (2) Frequency stability versus input voltage (Supply battery operating end point which shall be specified by the manufacturer DC 12V)

Refernce Frequency: 517.75MHz			
Power supply	Environment Temperature(°C)	Frequency Error (Hz)	Frequency Error (%)
DC 10.2V	25	1011	0.000195
DC 12.0V	25	1008	0.000195
DC 13.8V	25	1015	0.000196

Refernce Frequency: 517.75MHz				
Frequency Deviation measured with time Elapse(30 minutes)				
Environment Temperature(°C)	Frequency Error (Hz)	Frequency Error (%)	Limit (%)	Results
50	1021	0.000197	0.005	Pass
40	1008	0.000195		
30	1005	0.000194		
20	1008	0.000195		
10	1007	0.000194		
0	1009	0.000195		
-10	1008	0.000195		
-20	1009	0.000195		
-30	1010	0.000195		

Refernce Frequency: 529.75MHz			
Power supply	Environment Temperature(°C)	Frequency Error (Hz)	Frequency Error (%)
DC 10.2V	25	1009	0.000190
DC 12.0V	25	1006	0.000190
DC 13.8V	25	1010	0.000191

Refernce Frequency: 529.75MHz				
Frequency Deviation measured with time Elapse(30 minutes)				
Environment Temperature(°C)	Frequency Error (Hz)	Frequency Error (%)	Limit (%)	Results
50	1011	0.000191	0.005	Pass
40	1006	0.000190		
30	1006	0.000190		
20	1008	0.000190		
10	1007	0.000190		
0	1008	0.000190		
-10	1008	0.000190		
-20	1006	0.000190		
-30	1011	0.000191		

Refernce Frequency: 541.75MHz			
Power supply	Environment Temperature(°C)	Frequency Error (Hz)	Frequency Error (%)
DC 10.2V	25	1013	0.000187
DC 12.0V	25	1011	0.000192
DC 13.8V	25	1010	0.000187

Refernce Frequency: 541.75MHz				
Frequency Deviation measured with time Elapse(30 minutes)				
Environment Temperature(°C)	Frequency Error (Hz)	Frequency Error (%)	Limit (%)	Results
50	1010	0.000187	0.00500	Pass
40	1005	0.000186		
30	1005	0.000186		
20	1006	0.000186		
10	1007	0.000186		
0	1006	0.000186		
-10	1007	0.000186		
-20	1006	0.000186		
-30	1010	0.000187		

8 CONDUCTED EMISSION MEASUREMENT

8.1 LIMIT

Operating frequency band. In case the emission fall within the restricted band specified on Part 207(a) limit in the table below has to be followed.

FREQUENCY (MHz)	Conducted Emissionlimit (dBuV)	
	Quasi-peak	Average
0.15 -0.5	66 - 56 *	56 - 46 *
0.50 -5.0	56.00	46.00
5.0 -30.0	60.00	50.00

Note:

- (1) The tighter limit applies at the band edges.
- (2) The limit of " * " marked band means the limitation decreases linearly with the logarithm of the frequency in the range.

8.2 TEST PROCEDURE

The following table is the setting of the receiver

Receiver Parameters	Setting
Attenuation	10 dB
Start Frequency	0.15 MHz
Stop Frequency	30 MHz
IF Bandwidth	9 kHz

- a. The EUT was 0.8 meters from the horizontal ground plane and 0.4 meters from the vertical ground plane with EUT being connected to the power mains through a line impedance stabilization network (LISN). All other support equipments powered from additional LISN(s). The LISN provide 50 Ohm/ 50uH of coupling impedance for the measuring instrument.
- b. Interconnecting cables that hang closer than 40 cm to the ground plane shall be folded back and forth in the center forming a bundle 30 to 40 cm long.
- c. I/O cables that are not connected to a peripheral shall be bundled in the center. The end of the cable may be terminated, if required, using the correct terminating impedance. The overall length shall not exceed 1 m.
- d. LISN at least 80 cm from nearest part of EUT chassis.
- e. For the actual test configuration, please refer to the related Item –EUT Test Photos.

8.3 TEST SETUP

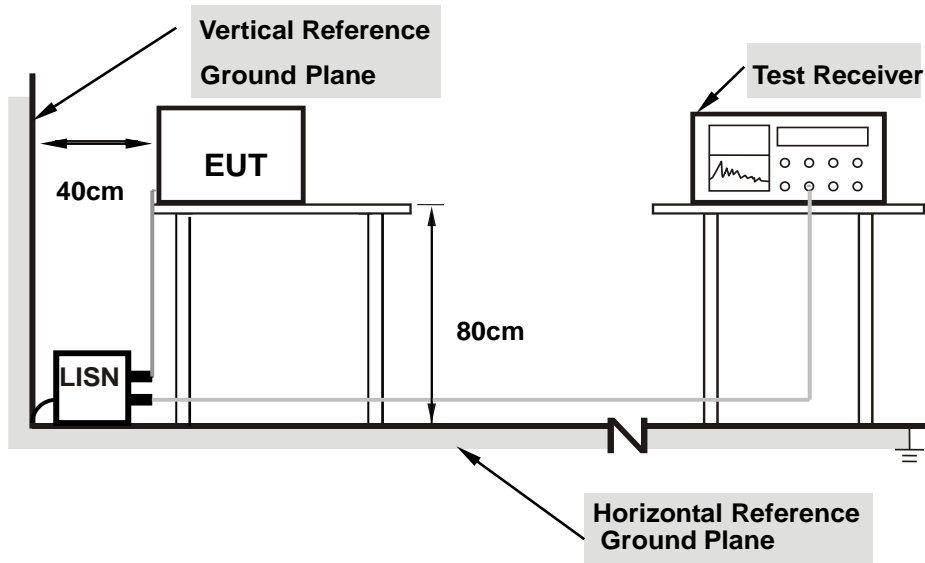

- Note:**
- 1.Support units were connected to second LISN.
 - 2.Both of LISNs (AMN) are 80 cm from EUT and at least 80 from other units and other metal planes

8.4 TEST RESULTS

Temperature:	25°C	Relative Humidity:	50%
Test Mode:	FM	Test Voltage:	AC 120V 60Hz
Result:	PASS		

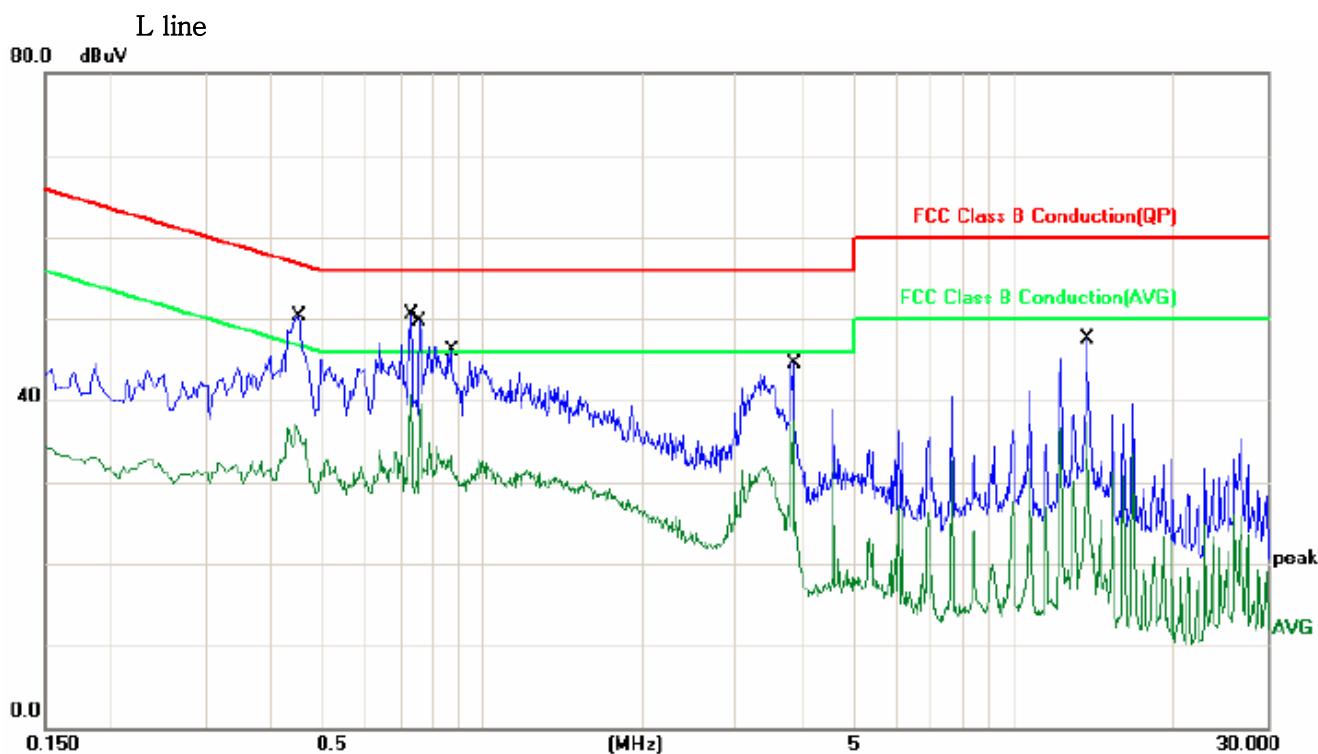

No.	Frequency (MHz)	Factor (dB)	Reading (dBuV)	Level (dBuV)	Limit (dBuV)	Margin (dB)	Detector
1	0.4500	10.47	36.26	46.73	56.87	-10.14	QP
2	0.4500	10.47	25.61	36.08	46.87	-10.79	AVG
3	0.7340	10.34	37.48	47.82	56.00	-8.18	QP
4	0.7340	10.34	29.12	39.46	46.00	-6.54	AVG
5	0.7620	10.33	36.53	46.86	56.00	-9.14	QP
6	0.7620	10.33	27.98	38.31	46.00	-7.69	AVG
7	0.8740	10.32	30.13	40.45	56.00	-15.55	QP
8	0.8740	10.32	21.48	31.80	46.00	-14.20	AVG
9	3.8500	10.73	26.96	37.69	56.00	-18.31	QP
10	3.8500	10.73	20.05	30.78	46.00	-15.22	AVG
11	13.7460	10.56	33.76	44.32	60.00	-15.68	QP
12	13.7460	10.56	25.80	36.36	50.00	-13.64	AVG

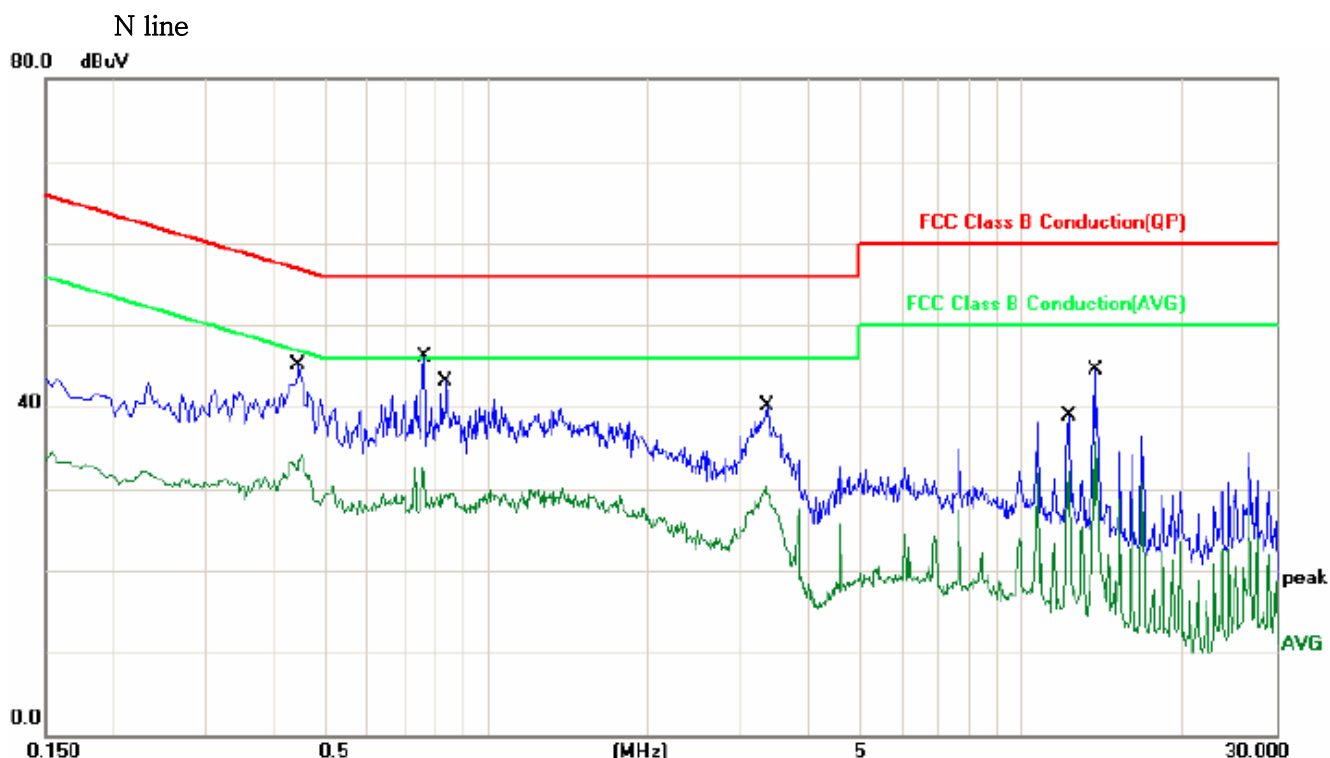

No.	Frequency (MHz)	Factor (dB)	Reading (dBuV)	Level (dBuV)	Limit (dBuV)	Margin (dB)	Detector
1	0.4460	10.49	30.50	40.99	56.95	-15.96	QP
2	0.4460	10.49	22.99	33.48	46.95	-13.47	AVG
3	0.7660	10.34	30.26	40.60	56.00	-15.40	QP
4	0.7660	10.34	21.48	31.82	46.00	-14.18	AVG
5	0.8420	10.33	25.14	35.47	56.00	-20.53	QP
6	0.8420	10.33	18.66	28.99	46.00	-17.01	AVG
7	3.3580	10.37	24.57	34.94	56.00	-21.06	QP
8	3.3580	10.37	18.27	28.64	46.00	-17.36	AVG
9	12.2540	10.53	27.81	38.34	60.00	-21.66	QP
10	12.2540	10.53	22.23	32.76	50.00	-17.24	AVG
11	13.7500	10.56	32.31	42.87	60.00	-17.13	QP
12	13.7500	10.56	26.94	37.50	50.00	-12.50	AVG

*****END OF THE REPORT*****