

FCC TEST REPORT

Reference No. : G-44-2015-01933

Applicant : Tianjin Empecs Medical Device Co., Ltd

Equipment Under Test (EUT):

Product Name : Blood Glucose Monitoring System

Model Name : Medisign MM1000 BT

Alt. Model Name : Medisign MM1100 BT, Smart Diabetes Bluetooth,
 Medisign MM1200 BT

Applied Standards : FCC Part 15 Subpart B

ANSI C63.4:2009

Date of Receipt : June 17, 2015

Date of Test : July 06, 2015 ~ July 13, 2015

Date of Issue : July 24, 2015

Test Results : Complied

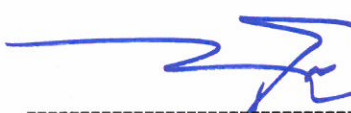
Tested by	:		 ----- Jinho Seo
Reviewed by	:		 ----- Paul Kang

Remarks :

This document is issued by the Company subject to its General Conditions of Service printed overleaf, available on request or accessible at <http://www.sgs.com/en/Terms-and-Conditions.aspx> and, for electronic format documents, subject to Terms and Conditions for Electronic Documents at www.sgs.com/terms_e-document.htm. The results shown in this test report refer only to the sample(s) tested unless otherwise stated. This Test Report cannot be reproduced, except in full

Contents

1. General Information.....	3
1.1 Client Information.....	3
1.2 Test Laboratory.....	3
1.3 General Information of E.U.T.	3
1.4 Operating Modes and Conditions.....	4
1.4 Operating Modes	4
1.4.1 Monitoring Method	4
1.5 Auxiliary Equipments	4
1.6 Cable List.....	5
1.7 System Configurations.....	5
1.8 Test System Layout	6
1.9 Modifications	6
1.10 Applicable Standards for Testing	7
1.11 Summary of Test Results.....	7
2. Emission Test.....	8
2.1 Test Results	8
2.2 Test Method and Limits.....	8
2.2.1 Test Method	8
2.2.2 Test Limits.....	8
2.3 Conducted Emission	9
2.3.1 Test Equipments	9
2.3.2 Test Site.....	9
2.3.3 Environment Conditions and data	10
2.4 Radiated Emission	11
2.4.1 Test Equipments	11
2.4.2 Test Site.....	11
2.4.3 Environment Conditions and data	12
Appendix A : Conducted Emission	13
Appendix B : Radiated Emission (3 m Scan Data)	14

1. General Information

1.1 Client Information

Applicant : Tianjin Empecs Medical Device Co., Ltd
 Address of Applicant : No. 35, Yingcheng Street, Hangu, Binhai New Area 300480
 Tianjin China

Manufacturer : Tianjin Empecs Medical Device Co., Ltd
 Address of Manufacturer : No. 35, Yingcheng Street, Hangu, Binhai New Area 300480
 Tianjin China

1.2 Test Laboratory

Name and Address : SGS Korea Co., Ltd.
 Giheung 1 Laboratory : 35, Giheungdanji-ro 121beon-gil, Giheung-gu, Yongin-si,
 Gyeonggi-do, Republic of Korea
 Giheung 2 Laboratory : 23, Giheungdanji-ro 24beon-gil, Giheung-gu, Yongin-si,
 Gyeonggi-do, Republic of Korea
 Gunpo Laboratory : 4, LS-ro 182beon-gil, Gunpo-si, Gyeonggi-do, 435-040
 Republic of Korea
 Phone : + 82 31 428 5700
 Fax : + 82 31 427 2370
 e-mail : paul.kang@sgs.com
 FCC Registration No : 367021

1.3 General Information of E.U.T.

Product Name	Blood Glucose Monitoring System
Model Name	Medisign MM1000 BT
Alt. Model Name	Medisign MM1100 BT, Smart Diabetes Bluetooth, Medisign MM1200 BT
Model Difference	Button & External body
FCC ID	2AFE8MM1000BT
Serial No.	-
Internal Clock Frequency	4 MHz
EMI Classification	Class B
Test Voltage	120 V a.c., 60 Hz (Notebook Computer)
Rated Voltage	3 V d.c.

1.4 Operating Modes and Conditions

1.4 Operating Modes

Operating mode	Operating condition
Mode 1 USB data communication	USB Data communication with notebook computer.
Mode 2 Blood glucose measurement	Blood glucose measurement status.

1.4.1 Monitoring Method

-

1.5 Auxiliary Equipments

Description	Model	Serial No.	Manufacturer
Notebook Computer	7665-AH6	L3-E5323	LENOVO
LCD Monitor	S2740Lb	CN-DP7D0G- 74261-352- 05CL	DELL Inc.
USB Keyboard	WK590	HDJ2011000 000	WINTEK
USB Mouse	M-U0026	810-002147	Logitech
Wireless Router	WG602v4	-	NETGEAR

1.6 Cable List

Start		END		Cable Spec.	
Name	I/O Port	Name	I/O Port	Length (m)	Shield
USB Data communication Mode					
EUT	USB	Notebook Computer	USB	1.0	Shield (Core 1ea)
Notebook Computer	USB	USB Keyboard	-	1.2	Unshield
	USB	USB Mouse	-	1.2	Unshield
	RGB	LCD Monitor	RGB	1.0	Unshield
	LAN	Wireless Router	LAN	1.5	Unshield
	DC IN	AC/DC Adapter	DC OUT	1.5	Unshield
AC/DC Adapter	AC IN	AC Source	-	1.2	Unshield
LCD Monitor	DC IN	AC/DC Adapter	DC OUT	1.0	Unshield
AC/DC Adapter	AC IN	AC Source	-	1.5	Unshield
Wireless Router	DC IN	Power Supply	DC OUT	1.0	Unshield
Power Supply	AC IN	AC Source	-	-	-
Blood glucose measurement Mode					
EUT	-	-	-	-	-

1.7 System Configurations

Description	Model	Serial No.	Manufacturer
Main Board	MEDISIGN_BLE Rev1.4b	PC27B-0014	CENTURY
Display	-	-	-

1.8 Test System Layout

- USB Data communication Mode

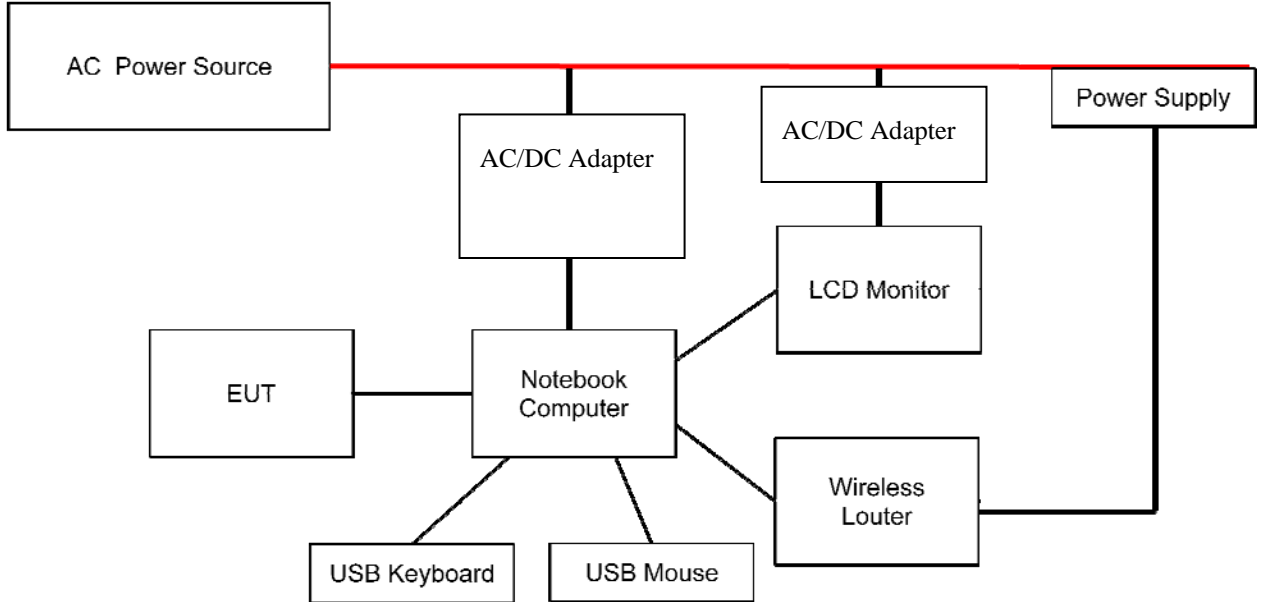

- Blood glucose measurement Mode

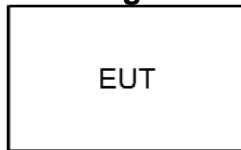

1.9 Modifications

There was no modified item during the test.

1.10 Applicable Standards for Testing

Standards	Status	Deviation
FCC Part 15 Subpart B	Applicable	No Deviation

1.11 Summary of Test Results

Test Item	Basic Standards	Results
Conducted Emission	ANSI C63.4 : 2009 FCC Part 15 Subpart B	Complied
Radiated Emission	ANSI C63.4 : 2009 FCC Part 15 Subpart B	Complied

EMISSION

2.1 Test Results

Test Items	Basic Standards	Test Results
Conducted Emission	ANSI C63.4 : 2009 FCC Part 15 Subpart B	Complied
Radiated Emission	ANSI C63.4 : 2009 FCC Part 15 Subpart B	Complied

2.2 Test Method and Limits

2.2.1 Test Method

Test Items	Measuring Frequency Range	RBW	Measuring Distance
Conducted Emission	0.15 MHz ~ 30 MHz	9 kHz	-
Radiated Emission	30 MHz ~ 1 GHz	120 kHz	10 m
	Above 1 GHz	1 MHz	3 m

2.2.2 Test Limits

-Conducted Emission Limits

Frequency Range	Limits(dB(μ V))		Class
	Quasi-peak	Average	
0.15 MHz ~ 0.5 MHz	79	66	Class A
0.5 MHz ~ 30 MHz	73	60	
0.15 MHz ~ 0.5 MHz	66 to 56	56 to 46	Class B
0.5 MHz ~ 5 MHz	56	46	
5 MHz ~ 30 MHz	60	50	

Note : The lower limit shall apply at the transition frequencies. The limit decreases linearly with the logarithm of the frequency in the range 0.15 MHz to 0.5 MHz.

Radiated Emission Limits below 1 GHz

Frequency Range	Limits(dB(μ V/m))		Class
	Quasi-peak		
30 MHz ~ 88 MHz	39.1		Class A
88 MHz ~ 216 MHz	43.5		
216 MHz ~ 960 MHz	46.4		
960 MHz ~ 1 GHz	49.5		
30 MHz ~ 88 MHz	40		Class B
88 MHz ~ 216 MHz	43.5		
216 MHz ~ 960 MHz	46		
960 MHz ~ 1 GHz	54		

-Radiated Emission Limits above 1 GHz (3m method)

Frequency Range	Limits(dB(μ V/m))		Class
	Average	Peak	
Above 1 GHz	59.5	79.5	Class A
Above 1 GHz	54	74	Class B

2.3 Conducted Emission

The initial preliminary exploratory scans were performed over the measuring frequency range(0.15 MHz to 30 MHz) using a max hold mode incorporating a Peak detector and Average detector and using the software of EMC32(Version V9.12.00 from R&S). The final test data was measured using a Quasi-Peak detector and Average detector.

2.3.1 Test Equipments

Description	Model No.	Manufacturer	S/N	Cal. Due Date
Two-Line V-Network	ENV216	R & S	100190	2015.12.25
Artificial Mains Networks	ESH2-Z5	R & S	100280	2016.04.03
Test Receiver	ESCI 7	R & S	100911	2015.12.24

Note : The calibration period of every equipment is 1 year.

2.3.2 Test Site

Shield Room in Gunpo Laboratory

2.3.3 Environment Conditions and data

Temperature: 23.5°C ~ 23.9°C
 Humidity: 34.0 %R.H. ~ 36.0 %R.H.
 Atmospheric Pressure: 100.5 kPa

Test Date: July 13, 2015

- USB Data Communication Mode

Freq. (MHz)	Line (H/N)	Level (dB μ V)		CL (dB)	LISN (dB)	Result (dB μ V)		Limit (dB μ V)		Margin (dB)	
		Q/P	A/V			Q/P	A/V	Q/P	A/V	Q/P	A/V
0.24	H	35.23	20.63	0.07	9.70	45.00	30.40	62.27	52.27	17.27	21.87
0.47	H	26.74	11.84	0.06	9.70	36.50	21.60	56.60	46.60	20.10	25.00
3.79	H	14.64	9.84	0.16	9.70	24.50	19.70	56.00	46.00	31.50	26.30
12.02	H	26.19	23.99	0.17	9.84	36.20	34.00	60.00	50.00	23.80	16.00
15.57	H	27.83	21.23	0.17	9.90	37.90	31.30	60.00	50.00	22.10	18.70
24.04	H	23.75	23.05	0.25	9.70	33.70	33.00	60.00	50.00	26.30	17.00

Measurement Uncertainty : ± 3.21 dB (The confidential level is about 95%, $k=2$)

- Note :
- Line (H) : Hot
 - Line (N) : Neutral
 - CL: Cable Loss
 - LISN : LISN Factor
 - Result = Level + CL + LISN
 - Margin = Limit – Result

See Appendix A (Conducted Emission)

2.4 Radiated Emission

The initial preliminary exploratory scans were performed at 3 m distance over the measuring frequency range(30 MHz to 1 GHz) using a max hold mode incorporating a Peak detector and using the software of EP5RE(Version Ver3.10.20 from TOYO). The final test data was measured using a Quasi-Peak detector below 1 GHz at 10 m distance. Measurements were made with the antenna positioned in both the horizontal and vertical planes of polarization. The antenna height was varied from 1 m to 4 m and the EUT was rotated 360° to find the maximum emitting point for each frequency.

2.4.1 Test Equipments

Description	Model No.	Manufacturer	S/N	Cal. Due Date
Bilog Antenna	VULB9163	SCHWARZBECK MESS- ELEKTRONIK	396	2016.06.16
Test Receiver	ESU26	R & S	100109	2016.03.03
Amplifier	8447F	HP	2944A03909	2015.08.27
Active Loop Antenna	FMZB1519	SCHWARZBECK	1519-039	2015.07.09

Note : Only the calibration period of Antennas is 2 years but the period of every equipment is 1 year.

2.4.2 Test Site

3 m Semi-Anechoic Chamber in Gunpo Laboratory

2.4.3 Environment Conditions and data

Below 1 GHz (3 m method)

Temperature: 26.6 °C ~ 26.8 °C

Humidity: 42.0 %R.H. ~ 45.0 %R.H

Atmospheric Pressure: 100.7 kPa

Test Date : July 10, 2015

- USB Data Communication Mode (30 MHz~ 1 GHz)

Freq. (MHz)	Level (dB μ V)	Pol. (H/V)	A (°)	H (cm)	AF (dB)	CL (dB)	Amp. (dB)	F/S (dB μ V/m)	Limit (dB μ V/m)	Margin (dB)
32.83	49.90	V	234	100	12.19	0.98	27.77	35.30	40.00	4.70
44.27	48.20	V	60	100	14.12	1.13	27.66	35.79	40.00	4.21
66.54	49.10	V	291	100	9.77	1.40	27.80	32.47	40.00	7.53
104.12	42.80	V	125	100	10.94	1.78	27.56	27.96	43.50	15.54
267.29	40.20	H	138	100	13.39	2.81	27.20	29.20	46.00	16.80
666.16	33.20	V	333	100	20.61	4.66	27.64	30.83	46.00	15.17

- Blood Glucose Measurement Mode (30 MHz~ 1 GHz)

Freq. (MHz)	Level (dB μ V)	Pol. (H/V)	A (°)	H (cm)	AF (dB)	CL (dB)	Amp. (dB)	F/S (dB μ V/m)	Limit (dB μ V/m)	Margin (dB)
42.25	33.7	V	30	300	14.2	1.1	27.7	21.3	40.0	18.7
53.12	33.4	V	63	300	13.7	1.3	27.8	20.6	40.0	19.5
89.05	34.9	V	27	100	9.9	1.6	27.8	18.6	43.5	24.9
109.70	33.0	H	152	100	10.5	1.8	27.5	17.8	43.5	25.7
307.66	34.3	H	178	100	14.4	3.0	26.9	24.8	46.0	21.2
385.79	34.8	H	277	200	16.2	3.4	26.8	27.5	46.0	18.5

Measurement Uncertainty (Horizontal) : ± 5.31 dB (The confidential level is about 95%, $k=2$)

Measurement Uncertainty (Vertical) : ± 5.73 dB (The confidential level is about 95%, $k=2$)

Note: • AF = Antenna Factor

• CL = Cable Loss

• F/S = Field Strength

• Pol.(H) = Horizontal

• Pol.(V) = Vertical

• Amp. = Amplifier Gain

• Margin = Limit – F/S

• F/S = Level + AF + CL – Amp.

• A : Angle

• H : Height

See Appendix B (Radiated Emission)

Appendix A : Conducted Emission

- USB Data Communication Mode

Neutral

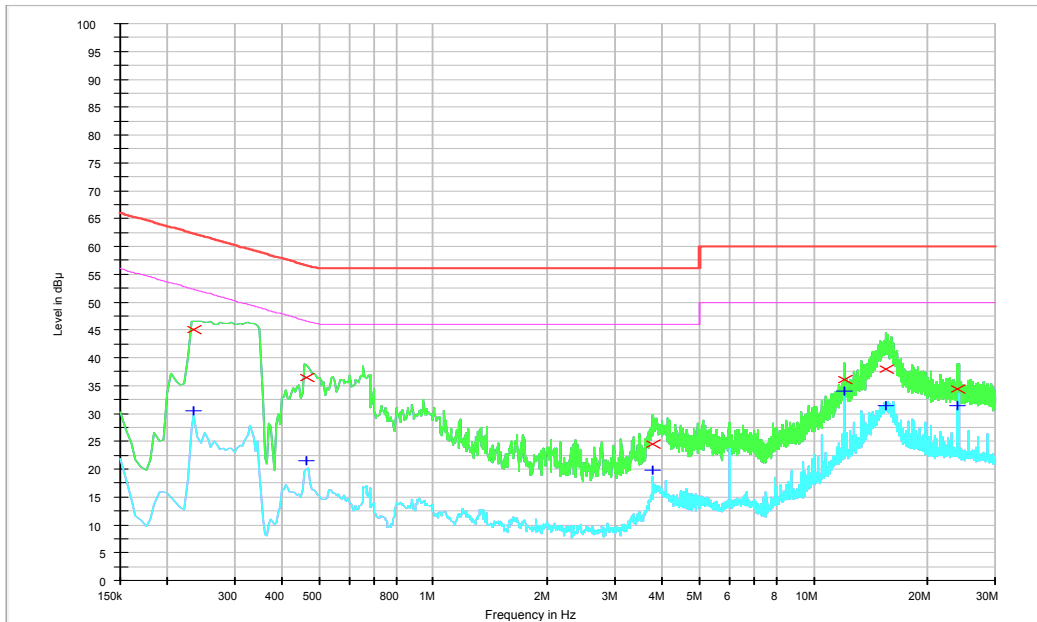

Hot

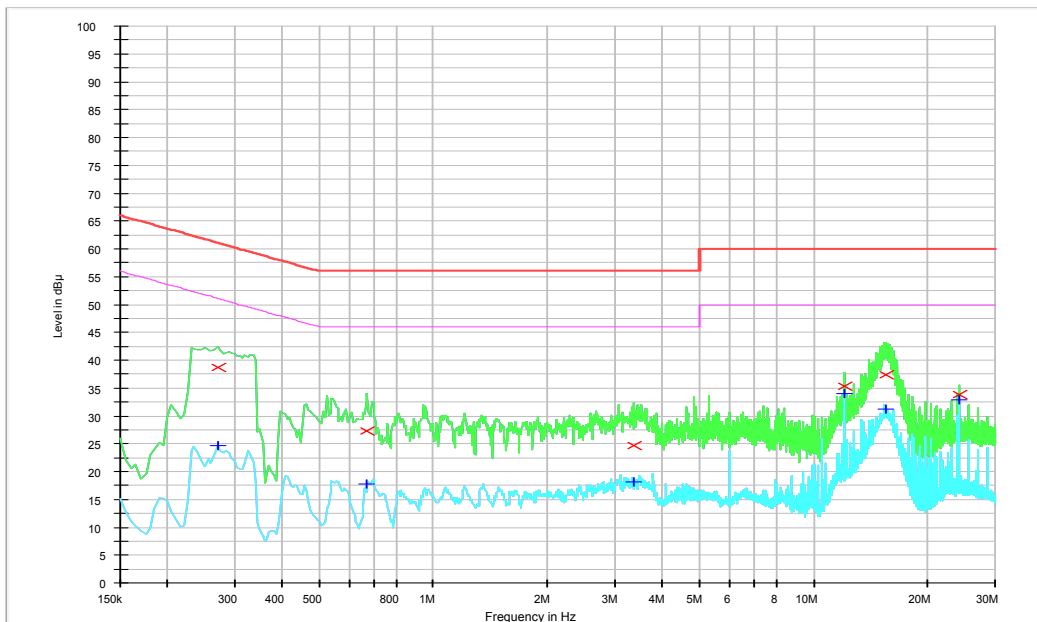

Appendix B : Radiated Emission (3 m Scan Data)

- USB Data Communication Mode (30 Mhz~ 1 GHz)

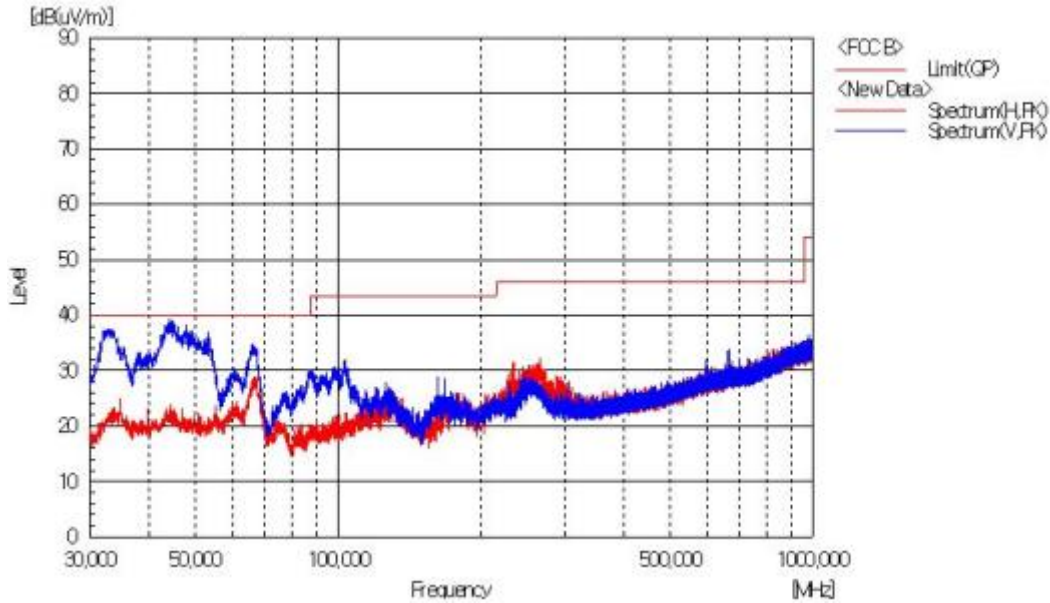

- Blood Glucose measurement Mode (30 Mhz~ 1 GHz)

