



AGES
14+

INSTRUCTION MANUAL



- Intelligent Hovering
- Intelligent Following
- Headless Mode
- One Key Flip
- 720P Wide Angle HD Camera
- High-precision Adjustable Steering Gear
- Low-power Auto Return
- Beyond Control Distance Auto Return
- Super Long Flying Time

FX-22C



6-Axis Gyro System 2.4GHz 5Channel 360°Flips

Please read the Instruction Manual carefully before using.
Please keep it for your further reference.

1.PRODUCT CONFIGURATION



Quadcopter X1



Transmitter X1



Blade A X2
Blade B X2



Holder X1



AC Adaptor X1



Protection Frame X4



screw driver X1



Card Reader X1



Phone Holder Screw X2



Protection Frame Screw X14



Instruction Manual X1

2.TRANSMITTER

2.1 Introduction of Transmitter

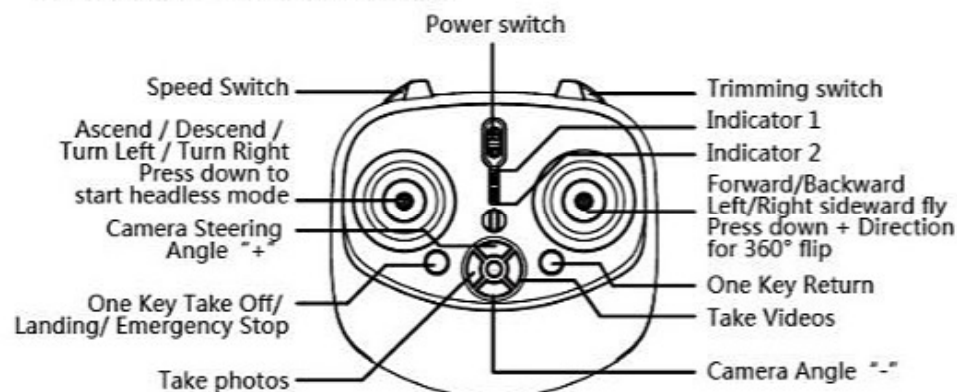

2.2 Install Batteries

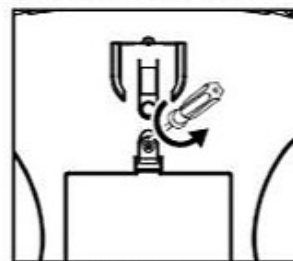

Open the battery compartment by loosening the screw on the cover with a screw driver.

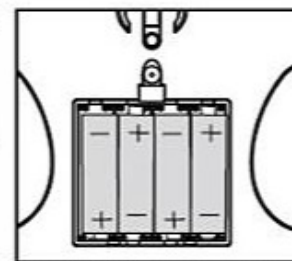

Put in 4 AA batteries with correct directions.



Cover the battery compartment and get it fastened with screw.

3. INSTALLATION PARTS

3.1 Installation of Smartphone Holder

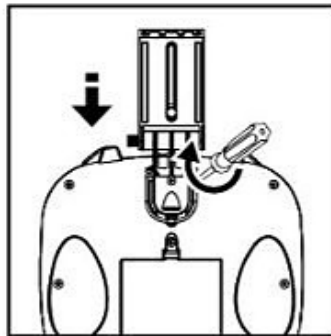

Install Smartphone holder

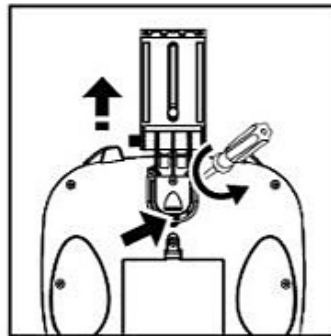

Disassemble Smartphone holder

★Hold smartphone holder and push it along the sliding chute, which at the back of controller. Smartphone holder is fastened properly when you hear a click, then please lock it with the phone holder screw.

★When you need to disassemble the smartphone holder, please undid the locked screw first. Then keep pressing down the button at the middle of sliding chute and pull it out.

★To adjust your smartphone, please adjust these three positions of the smartphone holder as shown.



3.2 Install and Disassemble Protection Frame

All the protection frames could be install or disassemble as consumer's needs.

★Take out all the protection frames and the screws from parts bag. Hold protection frame and press the screw positions down into the screws holes in motor seat, then lock the screws.

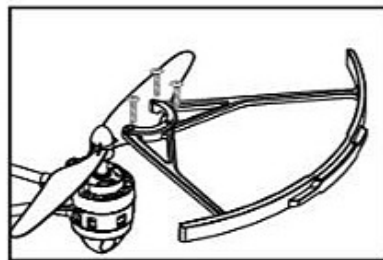

★When you need to disassemble the protection frame, please undid the locked screws and pull it out from motor seat.

4. CHARGING OF THE QUADCOPTER BATTERY

Please fully charged the quadcopter battery before flying. Open the battery door and take out the battery from quadcopter. Plug the AC adaptor into electricity supply and its indicator will light on as green. Then connect the output end to battery's input end, if adaptorVs indicator lights on as RED means battery is charging, if indicator lights on as GREEN means battery is fully charged. Charging time is about 150-180 mins. Flying time is about 20 mins.

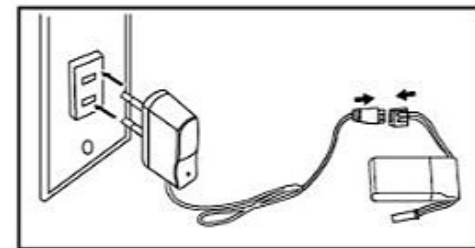
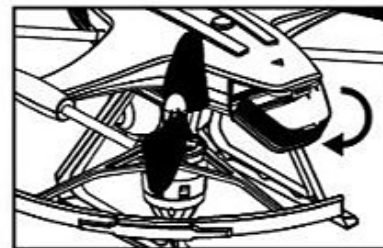

★★Please keep the battery with 50% power for extending the operating life of the battery if do no use the product for a long time.
★★Half of the battery fully charge time could keep the battery with 50% power.

5. OPERATION GUIDE

5.1 Start Steps

- ① Open the battery cover of quadcopter, connect battery with quadcopter, close battery cover.
- ② Longtime press power switch with two seconds, the four LED indicators under quadcopter's motor will flash, close the battery cover. Then place the quadcopter on the ground plane.

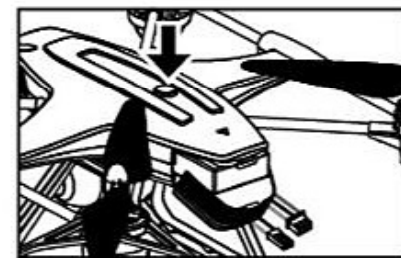

- ③ Turn on controller with two beeps, indicator 1 flash as green, push the left lever completely forward and the controller will beep one time, then pull it back completely and controller beep again. Both the indicator 1 of controller and four LED indicators of quadcopter will keep light on. Now quadcopter and controller are paired.
- ④ After paired quadcopter and controller, place the quadcopter on the ground plane, then rotate one circle the control lever of Direction clockwise. Four LED lights of quadcopter shall be flashing, and the gyro is calibrated and scanned for locking the location. QuadcopterCCs LED indicators keep light on and stop flashing means calibration is finished.

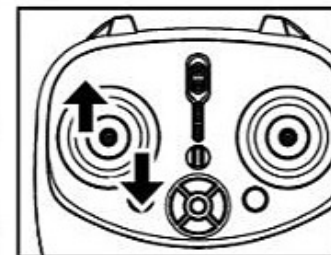

★★Before flying, the quadcopter must be calibrated on the ground plane to ensure it can fly steadily in the air.

★★The same operation can be made when the quadcopter cannot work properly from impact.

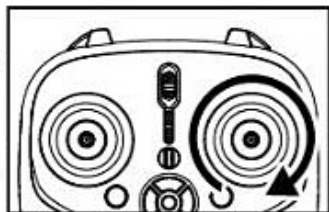

⑤ Pull left lever to lower-left corner and right lever to upper-left corner, controller's indicator 2 flash as RED, then place controller as ground plane and turn it to right or left till indicator 2 light off. Now controller's geomagnetism calibration is finished.

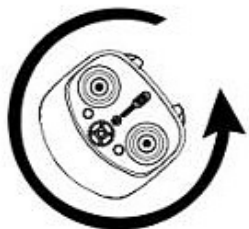
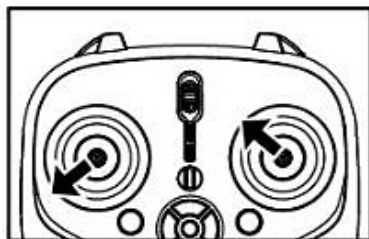

⑥ Pull left rod to lower-left corner and right lever to upper-left corner, quadcopter's LED indicators under motor seat will flash, place quadcopter as ground plane and turn it to right or left 2-3 circles. Then set quadcopter up 45 degrees from ground and turn it to left or right till its LED indicators keep light on. Now quadcopter's geomagnetism calibration is finished.

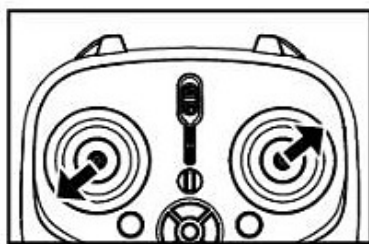

⑦ Place quadcopter on ground plane, keep its forward side (camera's forward direction) same as controller's forward direction. Pull left lever to lower-left corner and right rod to upper-right corner, controller's indicator 2 lights on as RED and quadcopter's LED indicators change from flash to light on. Now quadcopter's forward direction is locked and keep it same as controller.

4

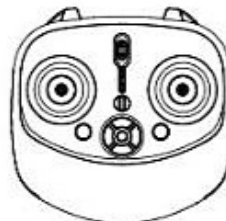
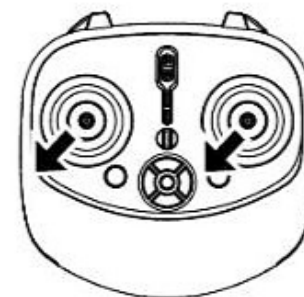
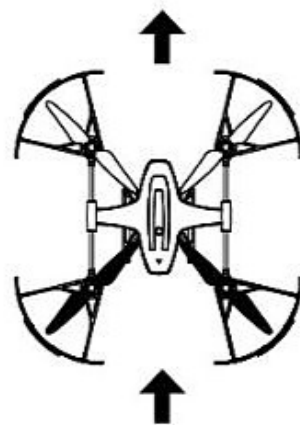

★★The geomagnetism calibration of both quadcopter and controller just need to set one time in the same area. No need to set before every fly time. But quadcopter should be locked the forward direction same as controller's before every fly time as step ⑦.

⑧ After locked the forward direction of quadcopter and controller, press down the left lever, controller with a beep, when blue indicators which at the transmitter tow sides flash five seconds then turn to lighting form, indicator 2 flash in red, and LED which under quadcopter's motor showing horse race lamp for five seconds then flash in opposite angles, quadcopter enter headless mode.

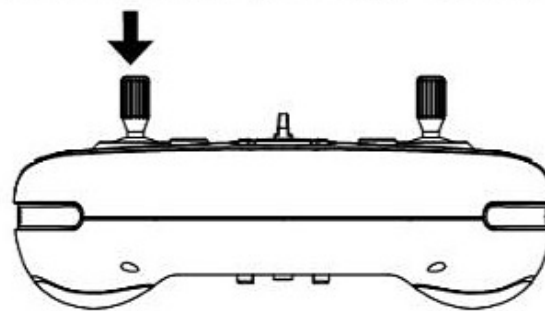

★After start headless mode, no matter how the quadcopter and player's direction is changed, quadcopter will fly according to the direction as controller's operation.

5

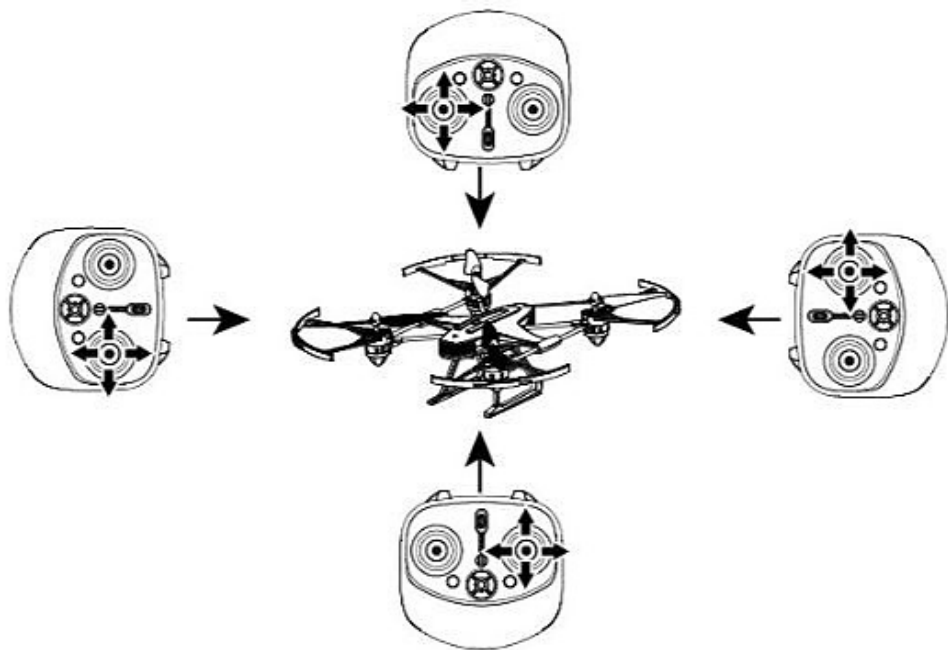

⑨ Pull the left and right lever completely to the inside corner as above pic and loosen them, quadcopter's blades are rotating in low speed. Push the accelerator to fly up the quadcopter and hovering in the sky. After loosen accelerator, quadcopter will be locked at this height. Quadcopter also could be auto take off, after press down the lower-right button of the left lever, controller with a beep, then quadcopter auto take off and hovering at a certain height.

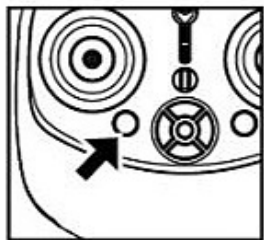
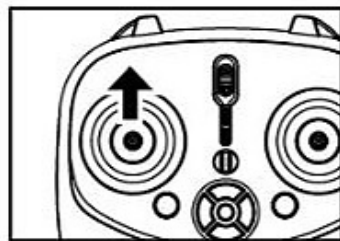

★★To first fly, please do the start steps as above.

★★As above start steps, if consumer do steps as ①-②-③-④-⑨, skip steps ⑤-⑥-⑦-⑧, quadcopter will in normal setting height mode. Random enter or exit headless mode when flying, for exit headless mode just need to press down the left lever controller.

5.2 Stop Fly Step

Pull the accelerator to the lowest position and keep seconds to landing quadcopter on the ground, then blades stop rotating. Quadcopter also be landed by press the button at left and near power switch.

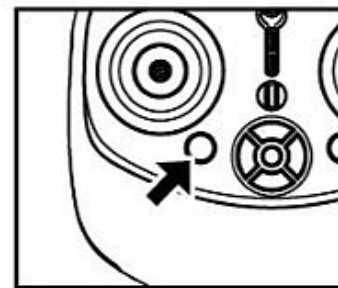
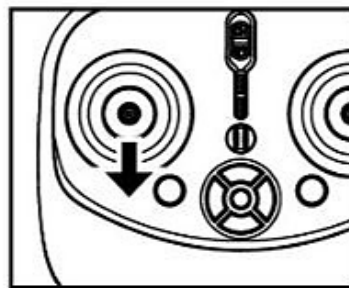

★★Emergency stop: Press the lower-right button of left lever twice continuously, then controller with two beeps, quadcopter's blades emergency stop rotating.

★★Or landed quadcopter on hand, hold quadcopter's stands and turn it over 90°, quadcopter also could be emergency stopped.

5.3 Trimming

Press down the key at top right corner with a beep into the fine-tune mode.

★ If the quadcopter skew towards forward, it shall be adjusted by pulling backward the right rod on the transmitter, the quadcopter's back two LED indicators under motor seat are flashing.

★ If the quadcopter skew towards backward, it shall be adjusted by pushing forward the right rod on the quadcopter's forward two LED indicators under motor seat are flashing.

★ If the quadcopter skews leftward, it shall be adjusted by pulling rightward the right rod on the transmitter, the quadcopter's right-side two LED indicators under motor seat are flashing.

★ If the quadcopter skew towards rightward, it shall be adjusted by pulling leftward the right rod on the transmitter, the quadcopter's left-side two LED indicators under motor seat are flashing.

★★After tuning, press down the button at the top right corner on the controller, with a beep, to quit running mode. Or do not move the right lever for three seconds to quit tuning mode automatically.

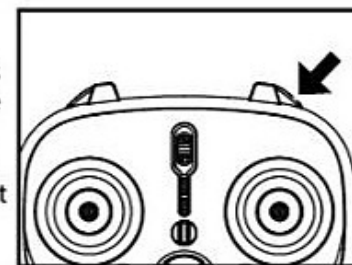

5.4 Reset Step

When the quadcopter flies defected from crash, and could not fly well by all calibration, please reset it as below:

- ① Press down the button at controller's top right corner, controller with a beep.
- ② Then turn the right lever a round clockwise. Quadcopter's four red LED indicators, which under motor seat, will change from flashing to light on, it means gyro calibration and controller reset are finished. Now the quadcopter also finish reset.

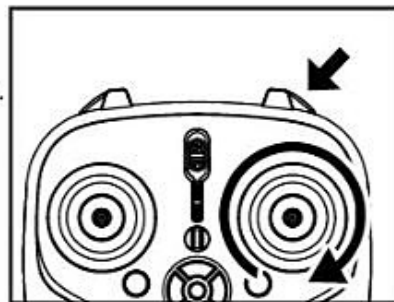

6. OPERATION AND CONTROL GUID

6.1 Speed Shift

During playing, use the button at top left corner for speed shift according to player's need.

Short press for speed switch, per short press increase one speed.

- ① Low speed: Press the speed shift button with a beep, quadcopter fly as 30% speed.
- ② Medium speed: Press the speed shift button with two beeps, quadcopter fly as 60% speed.
- ③ Fast speed: Press the speed shift button with three beeps, quadcopter fly as 100% speed.

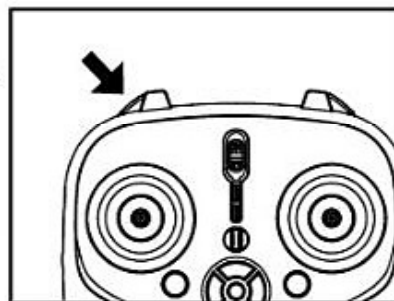

6.2 Basic Motion Operations

Push the left lever (accelerator) up and down, the quadcopter will ascend and descend accordingly.

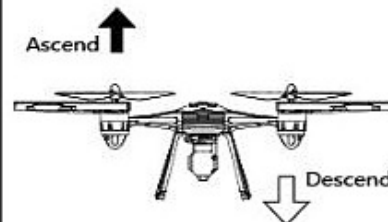

Push the left lever (accelerator) leftward and rightward, the quadcopter will turn left and turn right accordingly.

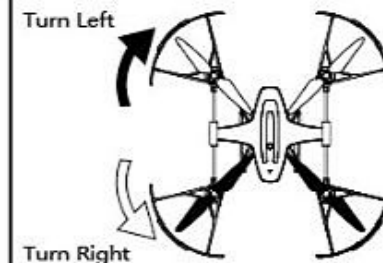
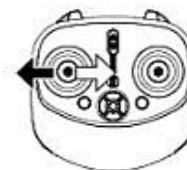

Push the right lever (direction), up and down, the quadcopter will go forward and backward accordingly.

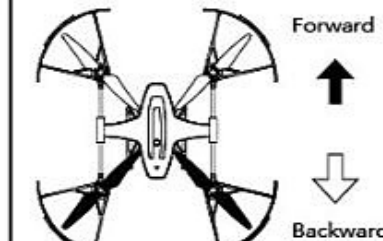
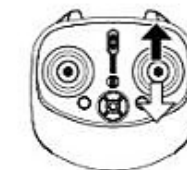

Push the right lever (direction), leftward and rightward, the quadcopter will go left sideward and right sideward accordingly.

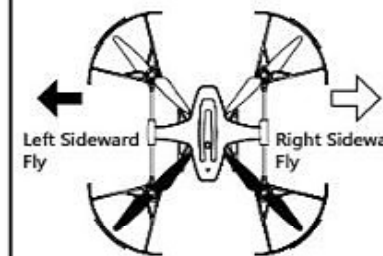

7. FLIPS

Flip Stunt must in hovering mode and exit headless mode.

When the drone in hovering state then press down the right lever with a beep into flip mode, then keep press it down and pull to forward, backward, leftward or rightward to flip the quadcopter in this direction.

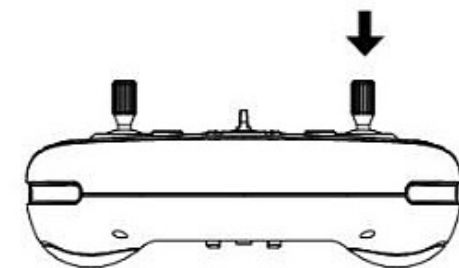

In order to get better playing, please keep 2m height and ascend, this will be easy to keep the height after flips.

7.1 Leftward flip

Press down the right lever, with a beep, push the lever leftward, the quadcopter will flip one circle leftward.



7.2 Rightward flip

Press down the right lever, with a beep, push the lever rightward, the quadcopter will flip one circle rightward.

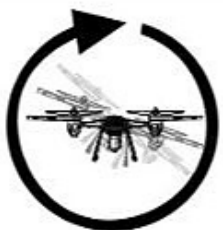

7.3 Forward flip

Press down the right lever, with a beep, push the lever forward, the quadcopter will flip one circle forward.



7.4 Backward flip

Press down the right lever, with a beep, pull the lever backward, the quadcopter will flip one circle backward.



8. ONE KEY RETURN (FOLLOWING MODE)

In fling time, press down the lower-left button of right lever, after controller with a beep, quadcopter will automatically return. If the quadcopter off course, please control the right lever fixed route. Quadcopter finish auto return, it will keep hovering in the sky about 5-8 meters away from controller.

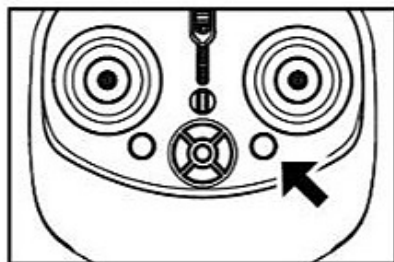

When controller is moved, quadcopter will move the same distance at same direction with controller. This is auto following function.

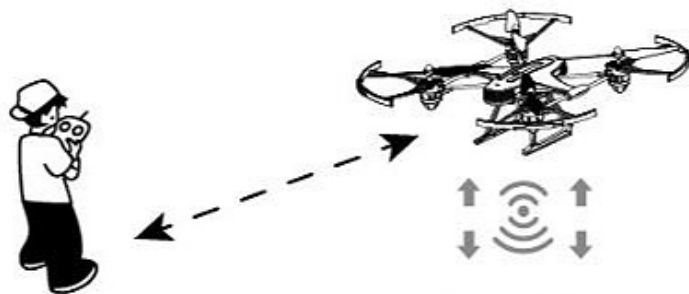

★Press down the lower-left button of right lever again, after controller with a beep, quadcopter stop return.

★To push the right lever "forward" also stop the quadcopter's return.

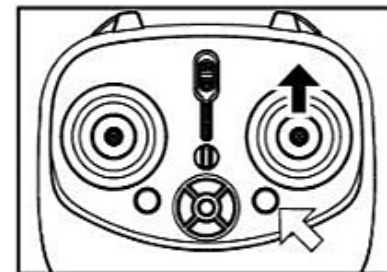

9. AUTO RETURN

9.1 Beyond Control Distance Auto Return

When quadcopter flight range out of factory set safe area, controller warns the user via vibrating and both sides' blue indicator flashing alerts, then quadcopter auto return back to the factory set safe range. Even it is controlled forward fly, once over the safe distance, quadcopter auto fly back to safe area.

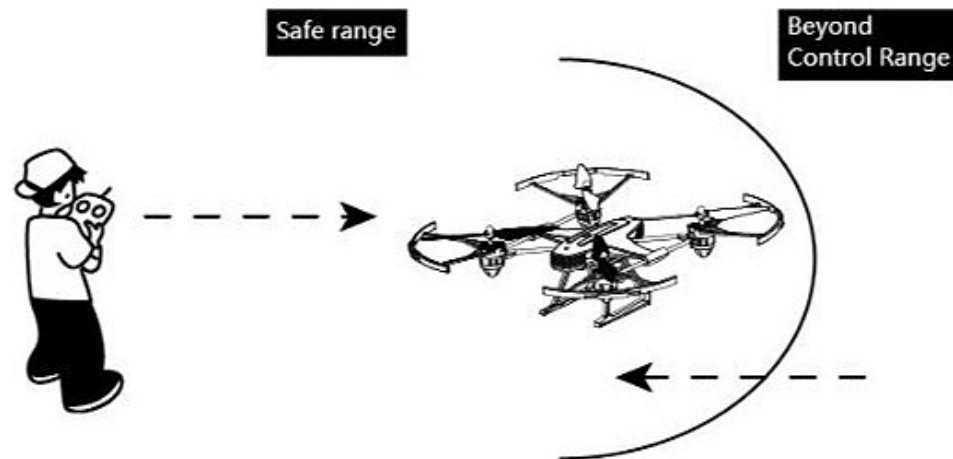

9.2 Low-power Auto Return

When quadcopter is low power, it will feedback the low-power signal to controller. Then controller warns the user via vibrating and both sides' blue indicator flashing alerts, quadcopter's four LED indicators under motor seats also flashing and start auto return. Quadcopter always hovering fly and keep 5-8 meters away from controller.



At this time, press down the lower-right button of left lever, controller with a beep, then quadcopter auto landed and blades stop rotating.

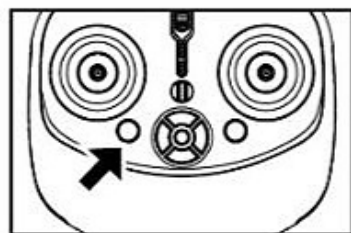

9.3 Controller low power return fly

When controller's batteries are low power, the blue LED lights at two sides of controller change to flash, then controller continue with sounds like "Di ... Di...".

Controller will send low power signal to quadcopter, then quadcopter's four LED lights under motor seats become flashing and quadcopter start return fly and keep hovering away from controller about 5-8 meters.

10.WIFI REAL-TIME TRANSMISSION

10.1 Download APP



Foreign Android
QR Code



ios QR Code



Domestic Android
QR Code

10.2 Menu Screen

①After signal matching with controller, the Wi-Fi indicator lights on and could be saw form the gap at bottom of quadcopter.

②Go to the setting button in your smartphone, open Wi-Fi, lock into the "Wifi FPV *****".

③Click to link till you see "Linked", means pairing.

④Open the downloaded APP "Wifi FPV *****", click the icon enter control menu and smartphone with real-time imager.

⑤If fail to connect Wi-Fi, it will be "Linking", please re-connect Wi-Fi.

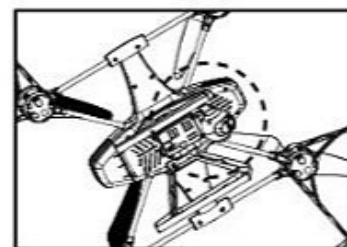

A: Go to settings B: Open Wi-Fi
C: Connect "Wifi FPV *****"



A: Open the "HK_skyline APP"
B: Click the "PLAY" button



Control interface

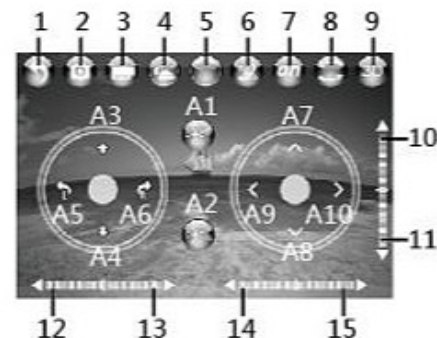

10.3 Icons Function Manual

- | | | | |
|--|-----------------------|--------------|--------------------------|
| 1.Return | 2.Take photo | 3.Take video | 4.Photo & video playback |
| 5.Speed: Slow 30% / Medium 60% / Fast 100% | 6.Gravity sensor mode | | |
| 7.Show / Hide joystick interface | 8.Reverse the screen | 9.3D VR | |

10/11: Forward/ backward fine-tune
 14/15: Left/Right sideward fly fine-tune
 A2: One key take off
 A5/A6: Left rotating/Right rotating
 A9/A10: Left/Right sideward fly

12/13: Left/Right rotating fine-tune
 A1: One key take off
 A3/A4: Ascend / Descend
 A7/A8: Forward/Backward

10.4 APP support 3D VR

Consumer could purchase related VR product for 3D flight. When click the "3D" icon in the upper right corner, control interface change to two parts. The VR's ware, focal length adjustment and other settings, please check the user manual of the VR.

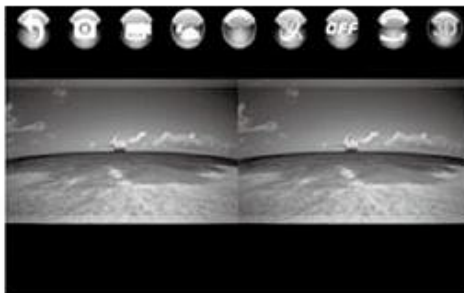

★★APP with different functions, like one key take off, one key landing, gravity sensor mode and so on. Consumer could learn all the operation guide from Helps.

10.5 High Precision Adjustable Steering Gear

The camera system of quadcopter built with HD camera and high precision adjustable steering gear, and it could be adjusted the shooting angle by the buttons on controller.

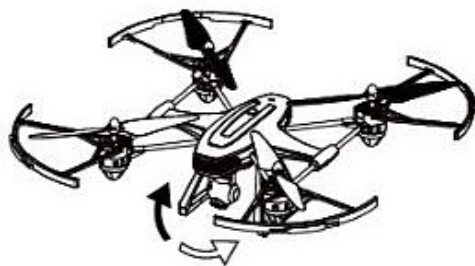
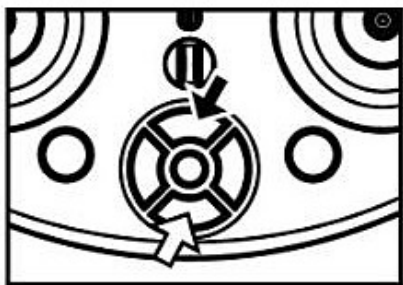

- ① Short press the upper button, camera will move up. When long press this button, camera will keep moving up.
 - ② When press the lower button, camera will move down. Camera could be moved over 90°.
- ★ To move the camera for keep video smooth and beauty.

10.6 Take Photo & Video

During flying time, taking photo and video by APP. Click the icons on smart photo or press the button on controller.

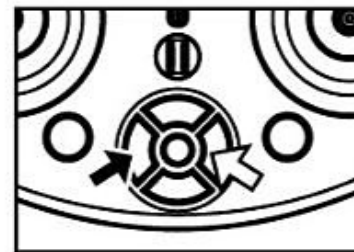

- ① Press the left button to take a picture, per press camera take a picture.
- ② Press the right button to start taking video then press again to stop and save the video.

10.7 View Saved Documents

- ① Finished taking picture or video, it could be viewed in the APP.
 - ② The document also saved in SD card of camera. To check document by computer, please turn off the power of quadcopter, press SD card and take it out first. Then take out the SD card reader from the parts bag, install the SD card, connect card reader to USB port of computer.
- ★★ When quadcopter fly out of Wi-Fi effective control range, picture or video are saved just in SD card not in APP. Once picture or video could not be find in APP, not means it was lost or not be saved.

11. FLIGHT ENVIRONMENT

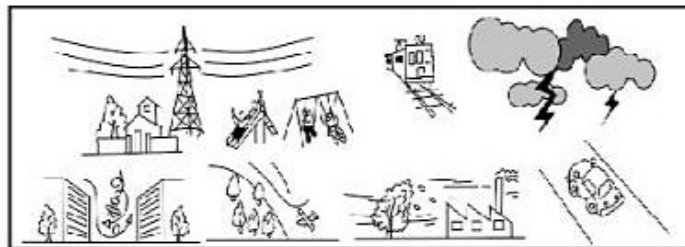

Do not operate the quadcopter in the bad conditions as mentioned for advoding accident or unexpected damages.

12. INSTALL BLADES

The blades shall be installed to designated location.

★ To install or change quadcopter's blade, check the letter on blade and make sure it is same as the letter on motor seat. Blade A should be install to the motor seat with letter A, and so blade B is install to motor seat with letter B. Or quadcopter could not fly in normal.

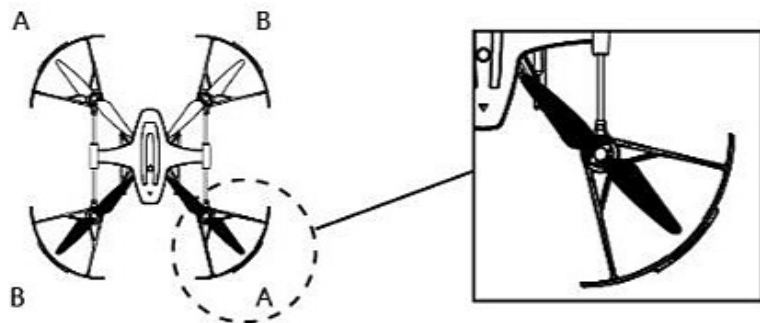

Both blade shaft and blade install hole with lock position to make sure the blade should be install at correct position.

① Take apart of the blade locker screw and the lower lampshade locker screw, then take out the damaged blade.

② Take out the new blade and aim it at the blade shaft till it hit the gear then turn it right or left till the inside locker position tight with the blade shaft.

③ Continue push blade till the end then lock the blade screw and lower lampshade screw.

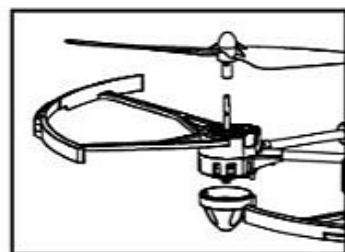

13.SAFETY PRECAUTIONS

① Stay away from obstacles

This product is workable outdoors Selecting barrier-free environment to advoding damage due to impact person or things.

② Leave away from moisture or heat source

The interior of an aircraft is made up of a number of sophisticated electronic components, so it must be protected from moisture or moisture as well as high temperature storms. Drying and so on.

③Lithium battery safety

It is strictly prohibited to use the lithium battery outside the factory to fly, the internal configuration of the lithium battery used by different manufacturers is Very different, so as not to cause damage to the aircraft electronic components and personal safety and other dangerous.

It is strictly prohibited to use the battery charger outside of the factory for charging, so as to avoid short circuit, expansion, deformation, or even fire, explosion and other dangerous.

④NiMH battery safety

Please notice the place of anode and cathode when pit in the batteries into controller. In order to protect the life of batteries, do not mix the new and old battery.

When quadcopter is not used for long periods of time, please take out all batteries to avoid battery leakage, battery failure. Please do not use leaky battery.

14.TROUBLE SHOOTING

Problem	Reason	Solution
The quadcopter did not respond	1. Singal matching failed. 2. Quadcopter or transmitter low voltage	1. Re-matching again. 2. Replace the transmitter batteries 3. Re-charge to quadcopter
Failed flips	1. Improper operation 2. Quadcopter LED flashes	1. Checking the instruction manual again 2. The battery of quadcopter is power off. Charging again.
Unable to take off	1. The blade is assembled wrong. 2. Blade impact deformation 3. Quadcopter LED flashes	1. Checking the instruction manual of installing blades 2. Righting blades or replacement blades 3. The low-voltage protection, re-charge to quadcopter
The quadcopter Shake	1. Blade impact deformation 2. gyroscope deviation	1. Righting blades or replacing blades. 2. Read the calibration part and do again.
The quadcopter response delay or interrupt signal	Transmitter low voltage	Replacing the battery of transmitter
The quadcopter can not hover	1. Quadcopter is not placed on a horizontal surface when singal matching. 2. Fine-tune of transmitter is not reset yet.	1. Re-matching 2. The transmitter should be reset

15.SPARE PARTS LIST



1.Transmitter



2.Phone holder



3.A/C adaptor

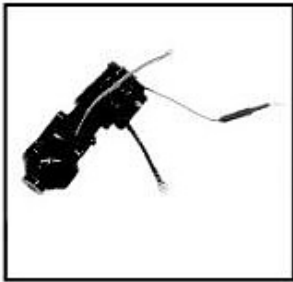

4.Camera sets



5.Li-ion battery



6.Upper body



7.Lower body



8.Stands + Antenna
Cover



9.Blade

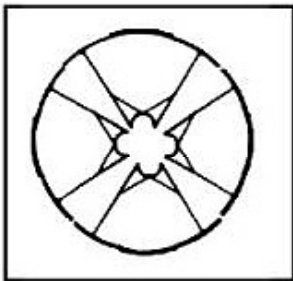

10.Protection frame

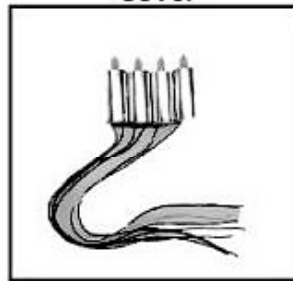

11.Positive inversion
motor



12.Motor seat



13.Motor cover



14.Lampshade

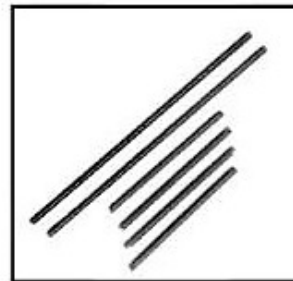

15.Long/short carbon
fiber tube

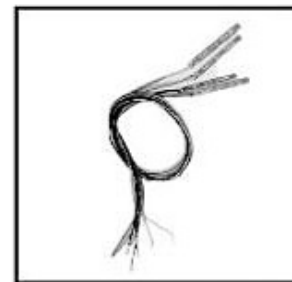

16.Light circuit of
forward / backward light



17.Gear with shaft



18.Forward and
backward light

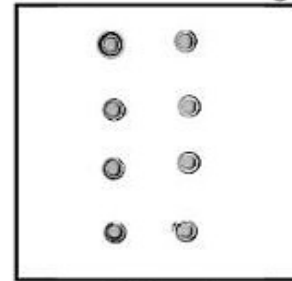

19.Bearing



20.Battery seat



21.Battery door/front
lampshade

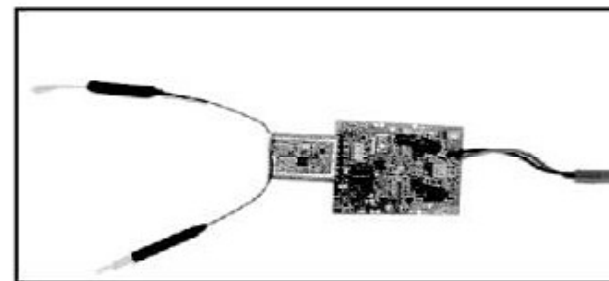

22.Receiver board



23.Steering engine
with Wi-Fi circuit board

This device complies with Part 15 of the FCC Rules. Operation is subject to the following two conditions: (1) this device may not cause harmful interference, and (2) this device must accept any interference received, including interference that may cause undesired operation.

Changes or modifications not expressly approved by the party responsible for compliance could void the user's authority to operate the equipment.

--- Thank you for buying this product, I wish you have a good time! ---