

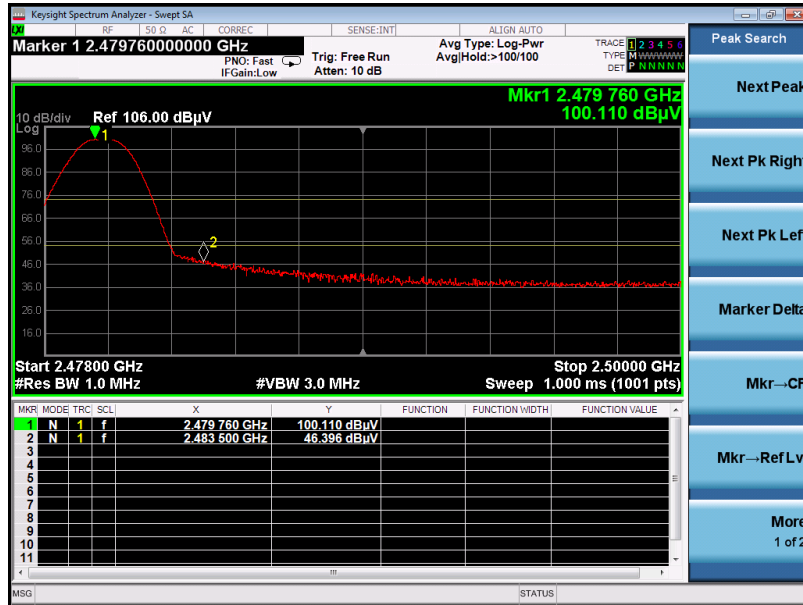

EUT	4K UST Laser Projector	Model Name	VA-LT002
Temperature	25° C	Relative Humidity	55.4%
Pressure	960hPa	Test Voltage	Normal Voltage
Test Mode	Mode 3	Antenna	Horizontal

PK



AV

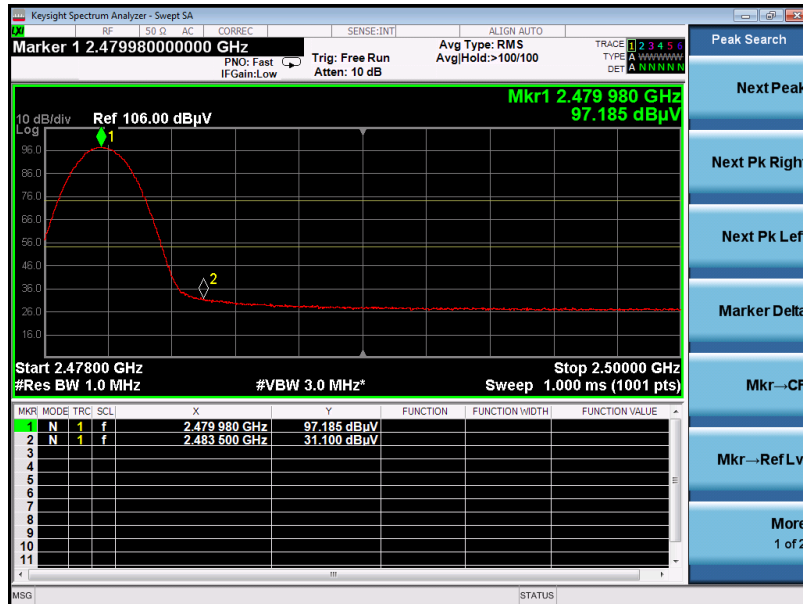

RESULT: PASS



EUT	4K UST Laser Projector	Model Name	VA-LT002
Temperature	25° C	Relative Humidity	55.4%
Pressure	960hPa	Test Voltage	Normal Voltage
Test Mode	Mode 3	Antenna	Vertical

PK

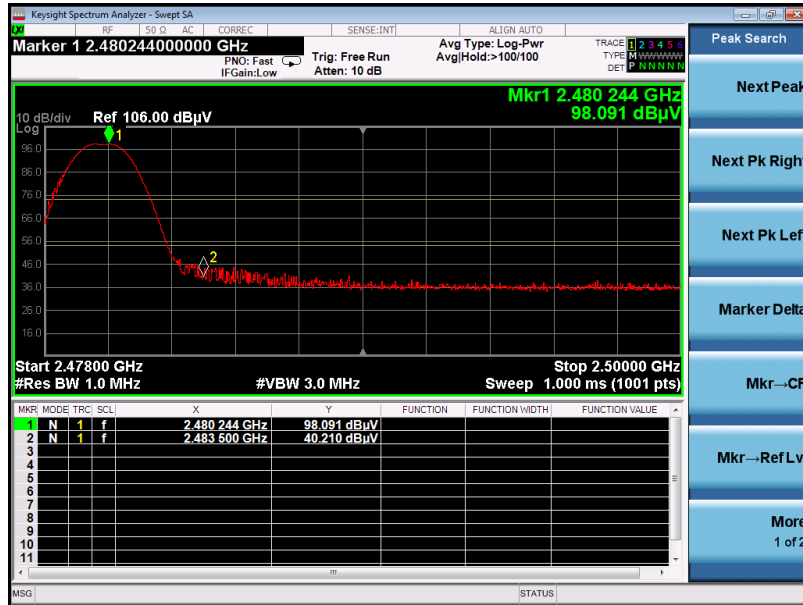

AV



RESULT: PASS

Note: The factor had been edited in the “Input Correction” of the Spectrum Analyzer. So the Amplitude of test plots is equal to Reading level plus the Factor in dB. Use the A dB(μV) to represent the Amplitude. Use the F dB(μV/m) to represent the Field Strength. So A=F.

8. LINE CONDUCTED EMISSION TEST

8.1. LIMITS OF LINE CONDUCTED EMISSION TEST

Frequency	Maximum RF Line Voltage	
	Q.P.(dBuV)	Average(dBuV)
150kHz~500kHz	66-56	56-46
500kHz~5MHz	56	46
5MHz~30MHz	60	50

Note:

1. The lower limit shall apply at the transition frequency.
2. The limit decreases linearly with the logarithm of the frequency in the range 0.15 MHz to 0.50MHz.

8.2. BLOCK DIAGRAM OF LINE CONDUCTED EMISSION TEST

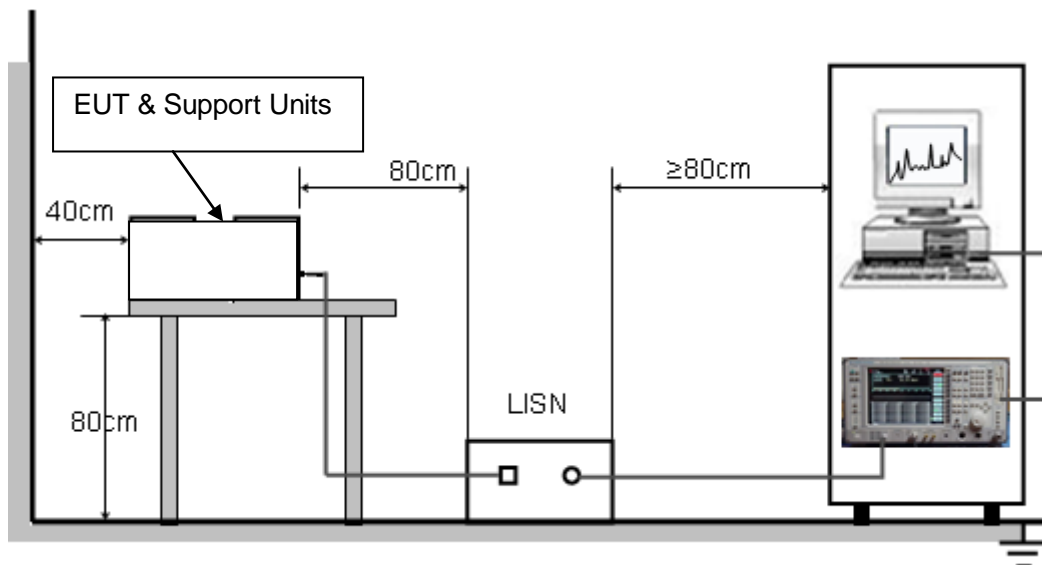



8.3. PRELIMINARY PROCEDURE OF LINE CONDUCTED EMISSION TEST

1. The equipment was set up as per the test configuration to simulate typical actual usage per the user's manual. When the EUT is a tabletop system, a wooden table with a height of 0.8 meters is used and is placed on the ground plane as per ANSI C63.10 (see Test Facility for the dimensions of the ground plane used). When the EUT is a floor-standing equipment, it is placed on the ground plane which has a 3-12 mm non-conductive covering to insulate the EUT from the ground plane.
2. Support equipment, if needed, was placed as per ANSI C63.10.
3. All I/O cables were positioned to simulate typical actual usage as per ANSI C63.10.
4. All support equipments received AC120V/60Hz power from a LISN, if any.
5. The EUT received charging voltage by adapter which received 120V/60Hz power by a LISN..
6. The test program was started. Emissions were measured on each current carrying line of the EUT using a spectrum Analyzer / Receiver connected to the LISN powering the EUT. The LISN has two monitoring points: Line 1 (Hot Side) and Line 2 (Neutral Side). Two scans were taken: one with Line 1 connected to Analyzer / Receiver and Line 2 connected to a 50 ohm load; the second scan had Line 1 connected to a 50 ohm load and Line 2 connected to the Analyzer / Receiver.
7. Analyzer / Receiver scanned from 150 kHz to 30MHz for emissions in each of the test modes.
8. During the above scans, the emissions were maximized by cable manipulation.
9. The test mode(s) were scanned during the preliminary test.

Then, the EUT configuration and cable configuration of the above highest emission level were recorded for reference of final testing.

8.4. FINAL PROCEDURE OF LINE CONDUCTED EMISSION TEST

1. EUT and support equipment was set up on the test bench as per step 2 of the preliminary test.
2. A scan was taken on both power lines, Line 1 and Line 2, recording at least the six highest emissions. Emission frequency and amplitude were recorded into a computer in which correction factors were used to calculate the emission level and compare reading to the applicable limit. If EUT emission level was less -2dB to the A.V. limit in Peak mode, then the emission signal was re-checked using Q.P and Average detector.
3. The test data of the worst case condition(s) was reported on the Summary Data page.



8.5. TEST RESULT OF LINE CONDUCTED EMISSION TEST

LINE CONDUCTED EMISSION TEST-L

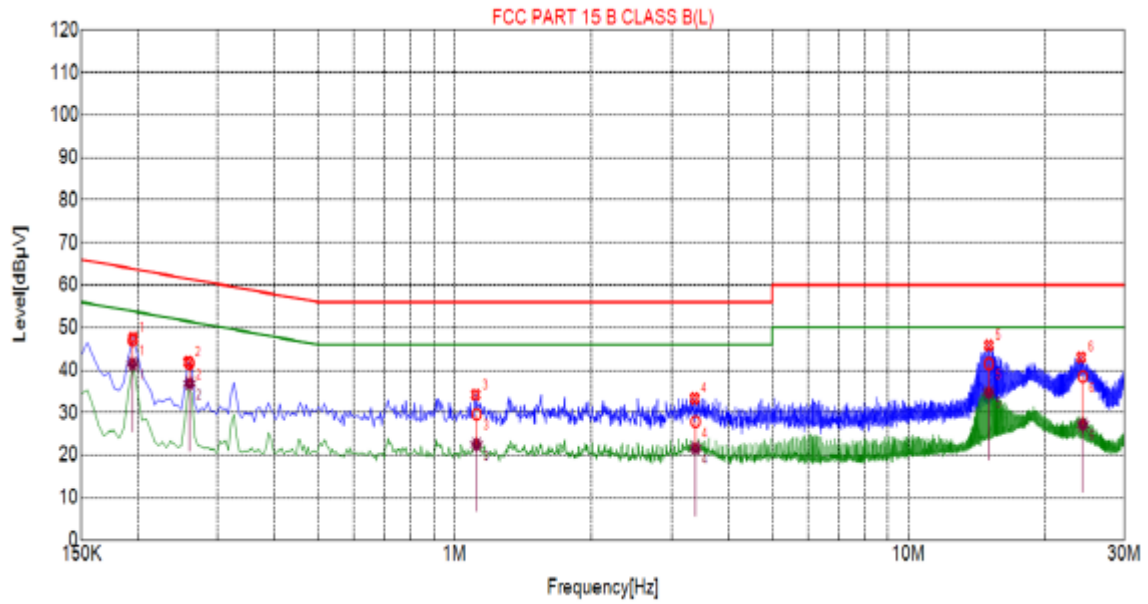

Suspected List						
NO.	Freq. [MHz]	Level [dBµV]	Factor [dB]	Limit [dBµV]	Margin [dB]	Detector
1	0.1950	47.65	10.03	63.82	16.17	PK
2	0.2580	41.88	10.04	61.50	19.62	PK
3	1.1130	34.23	10.08	56.00	21.77	PK
4	3.3720	33.35	10.24	56.00	22.65	PK
5	15.0495	45.85	9.96	60.00	14.15	PK
6	24.0675	43.02	10.22	60.00	16.98	PK

Final Data List								
NO.	Freq. [MHz]	Factor [dB]	QP Value [dBµV]	QP Limit [dBµV]	QP Margin [dB]	AV Value [dBµV]	AV Limit [dBµV]	AV Margin [dB]
1	0.1946	10.03	46.98	63.84	16.86	41.46	53.84	12.38
2	0.2598	10.03	41.63	61.44	19.81	36.89	51.44	14.55
3	1.1181	10.08	29.61	56.00	26.39	22.53	46.00	23.47
4	3.3863	10.24	27.88	56.00	28.12	21.70	46.00	24.30
5	15.0547	9.96	41.51	60.00	18.49	34.79	50.00	15.21
6	24.2709	10.23	38.47	60.00	21.53	27.18	50.00	22.82

RESULT: PASS



LINE CONDUCTED EMISSION TEST-N

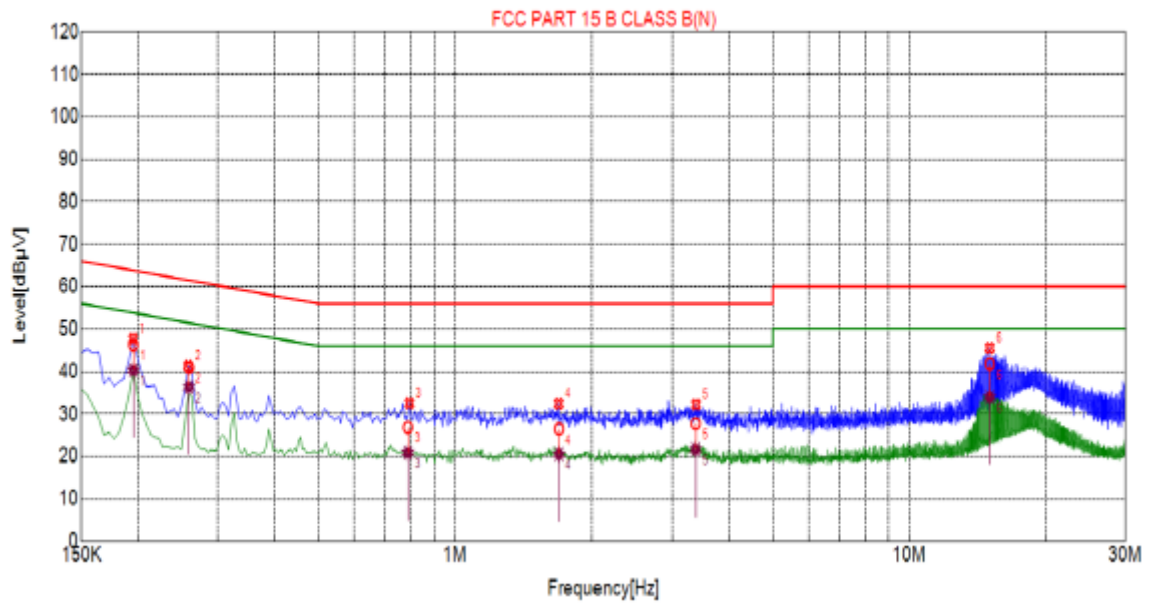

Suspected List						
NO.	Freq. [MHz]	Level [dBµV]	Factor [dB]	Limit [dBµV]	Margin [dB]	Detector
1	0.1950	47.73	10.03	63.82	16.09	PK
2	0.2580	41.28	10.04	61.50	20.22	PK
3	0.7935	32.55	10.05	56.00	23.45	PK
4	1.6935	32.45	10.13	56.00	23.55	PK
5	3.3855	32.24	10.24	56.00	23.76	PK
6	15.0495	45.56	9.96	60.00	14.44	PK

Final Data List								
NO.	Freq. [MHz]	Factor [dB]	QP Value [dBµV]	QP Limit [dBµV]	QP Margin [dB]	AV Value [dBµV]	AV Limit [dBµV]	AV Margin [dB]
1	0.1951	10.03	46.23	63.82	17.59	40.30	53.82	13.52
2	0.2589	10.04	40.92	61.47	20.55	36.32	51.47	15.15
3	0.7870	10.05	26.85	56.00	29.15	20.88	46.00	25.12
4	1.6963	10.13	26.50	56.00	29.50	20.55	46.00	25.45
5	3.3788	10.24	27.75	56.00	28.25	21.69	46.00	24.31
6	15.0539	9.96	41.80	60.00	18.20	33.95	50.00	16.05

RESULT: PASS

Note: All the test modes had been tested, the mode 1 was the worst case. Only the data of the worst case would be record in this test report.

APPENDIX A: PHOTOGRAPHS OF TEST SETUP

RADIATED EMISSION TEST SETUP BELOW 1GHZ

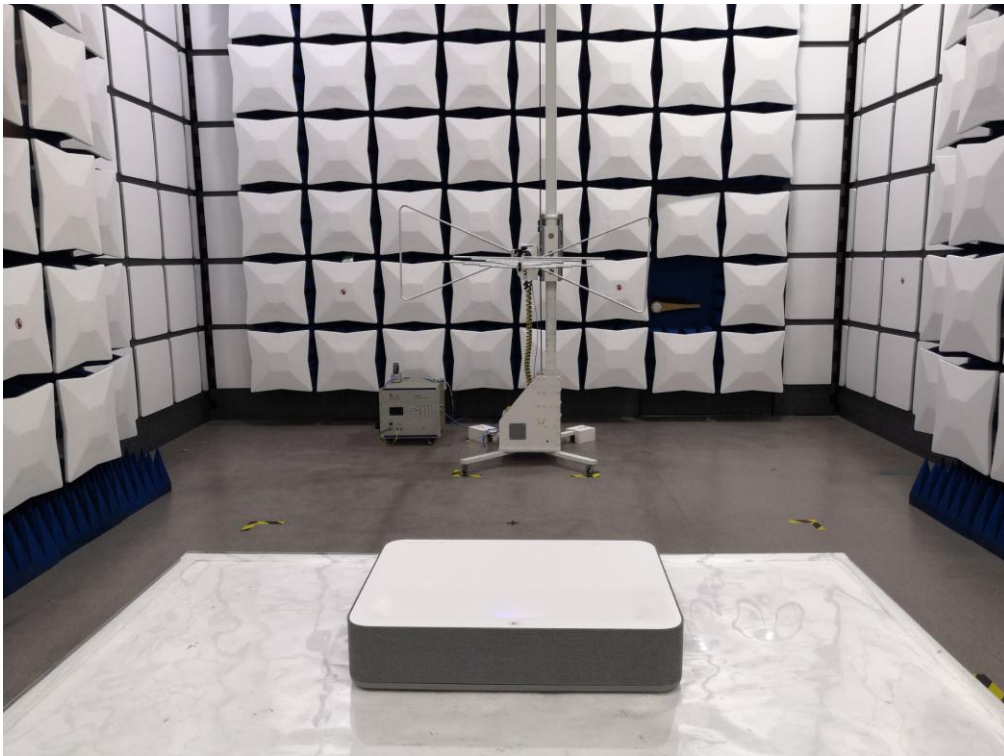

RADIATED EMISSION TEST SETUP ABOVE 1GHZ





Conducted Emission

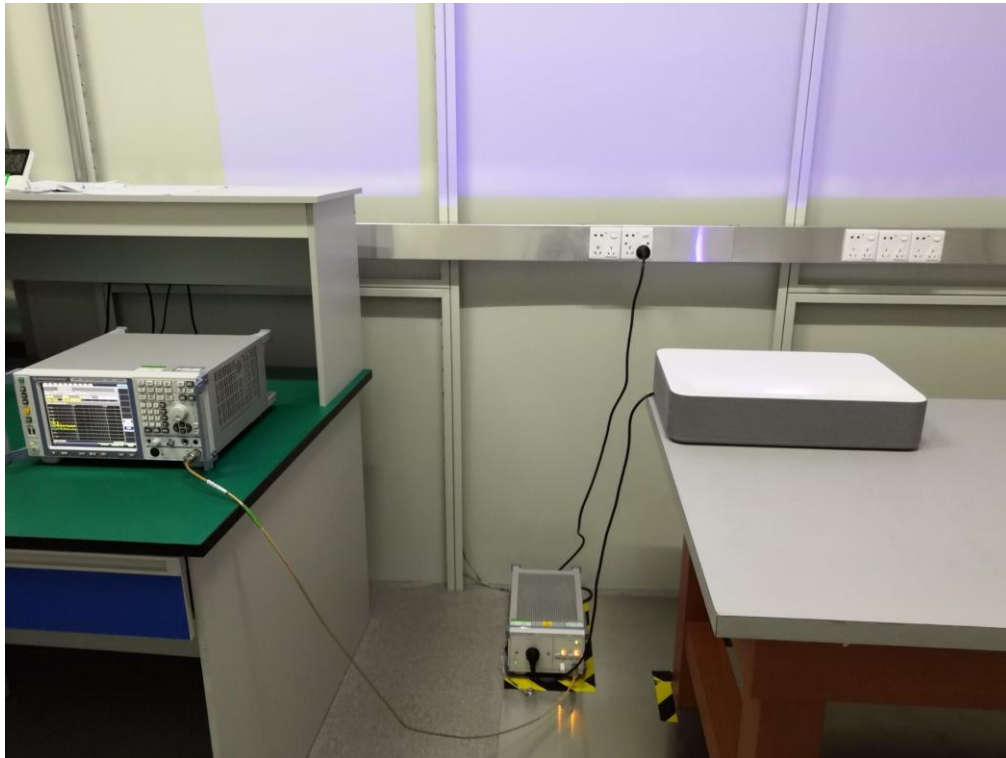

APPENDIX B: PHOTOGRAPHS OF EUT

TOP VIEW OF EUT



BOTTOM VIEW OF EUT

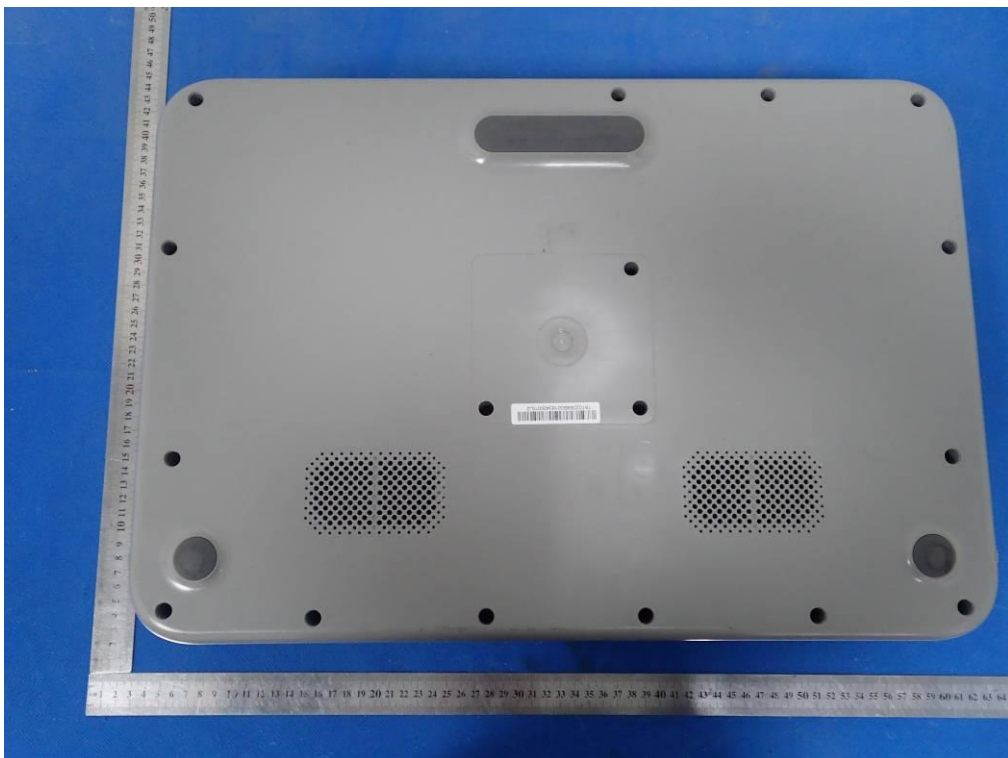



FRONT VIEW OF EUT

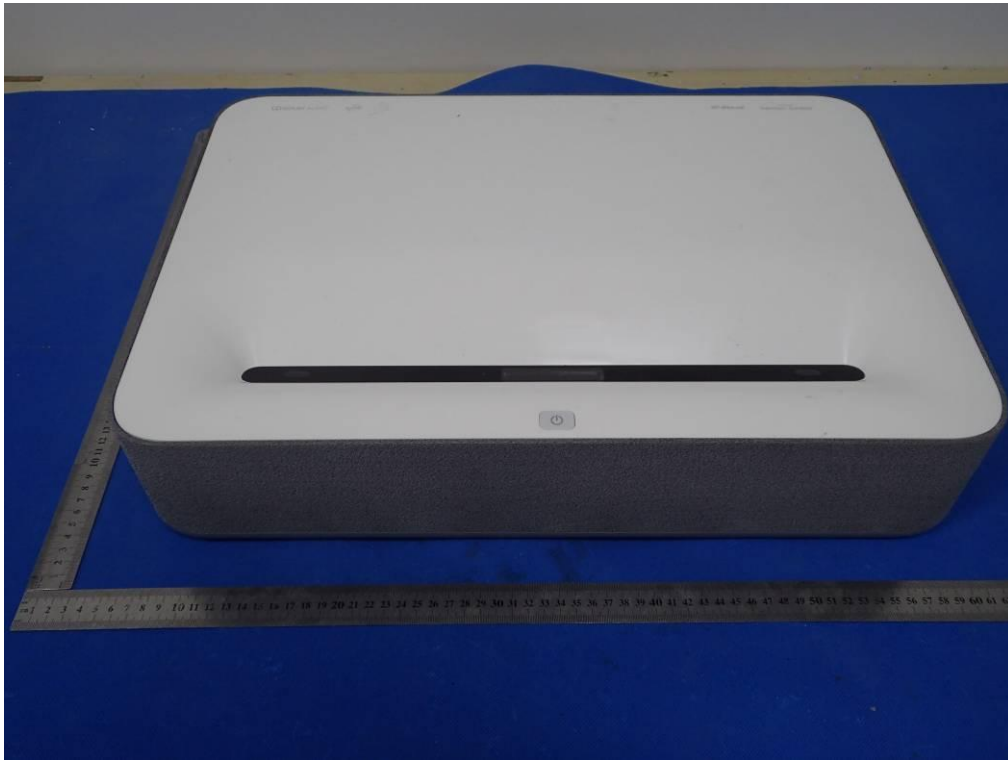

BACK VIEW OF EUT



LEFT VIEW OF EUT



RIGHT VIEW OF EUT



VIEW OF EUT(PORT)



OPEN VIEW OF EUT-1

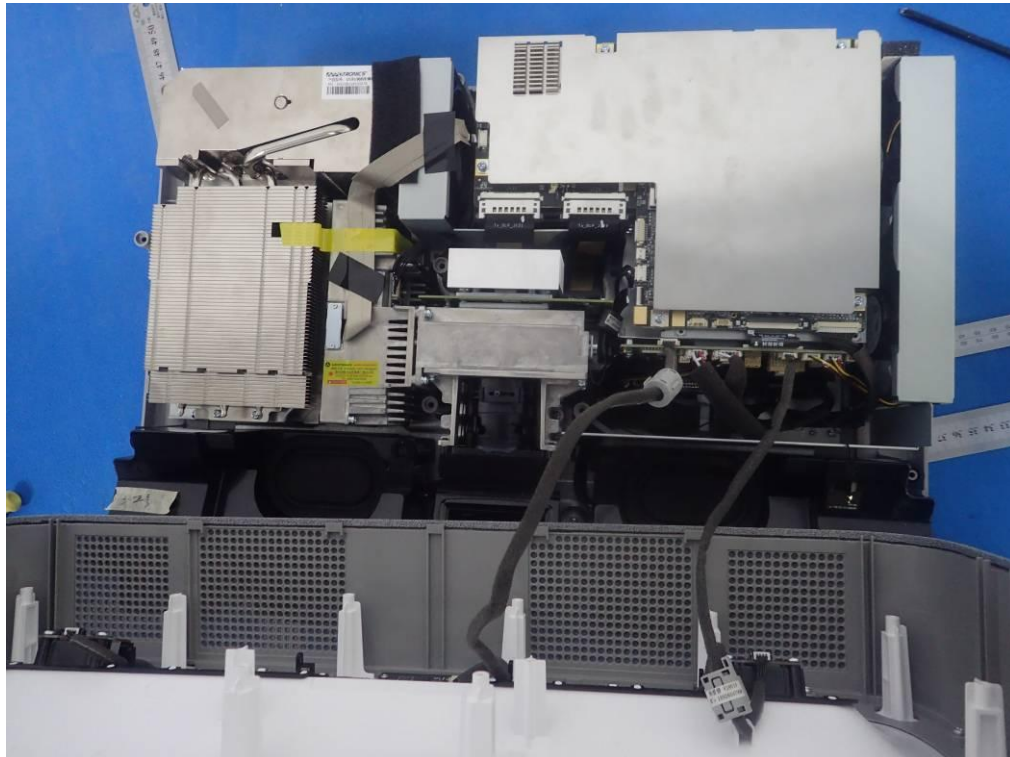

OPEN VIEW OF EUT-2

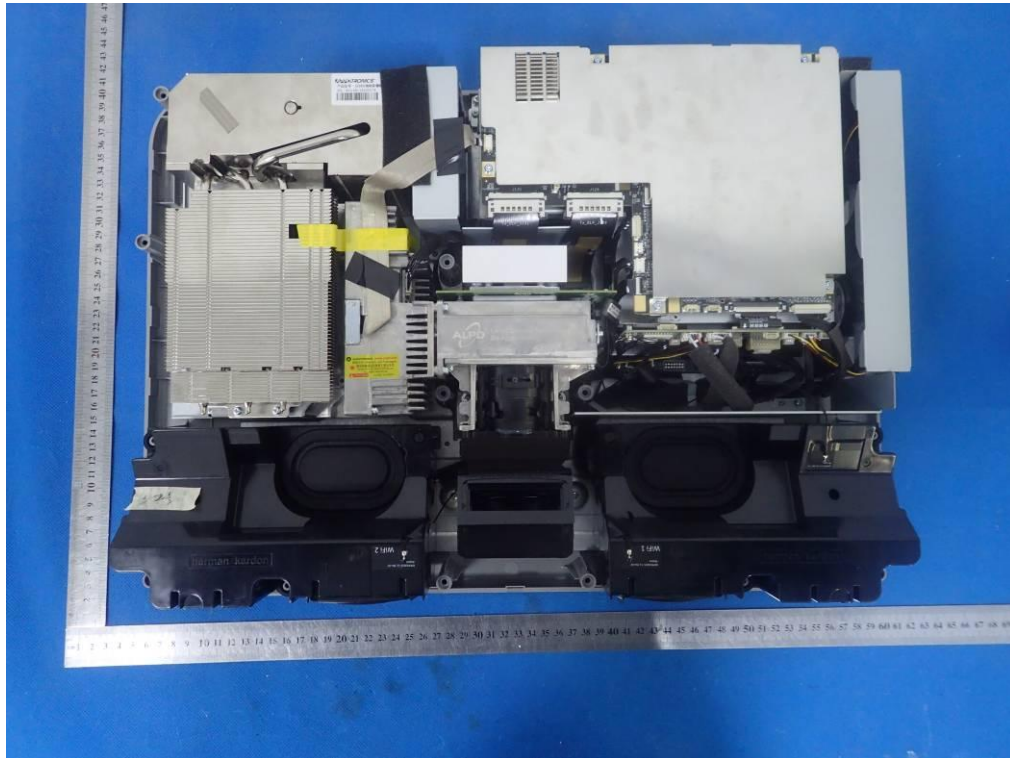

OPEN VIEW OF EUT-3

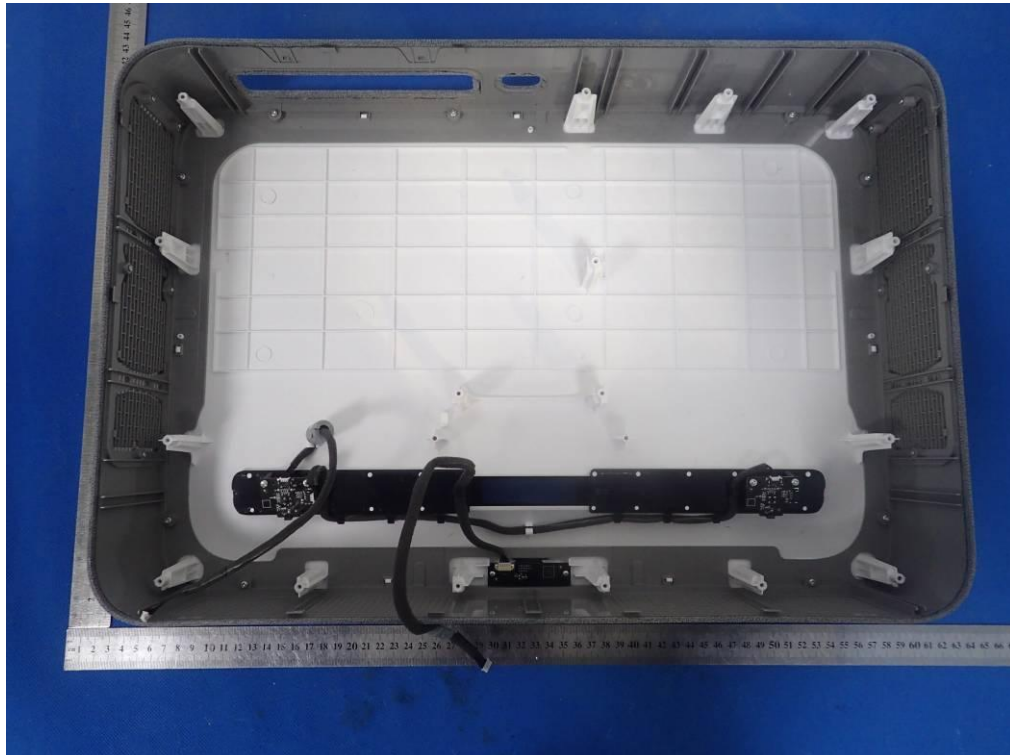



OPEN VIEW OF EUT-4

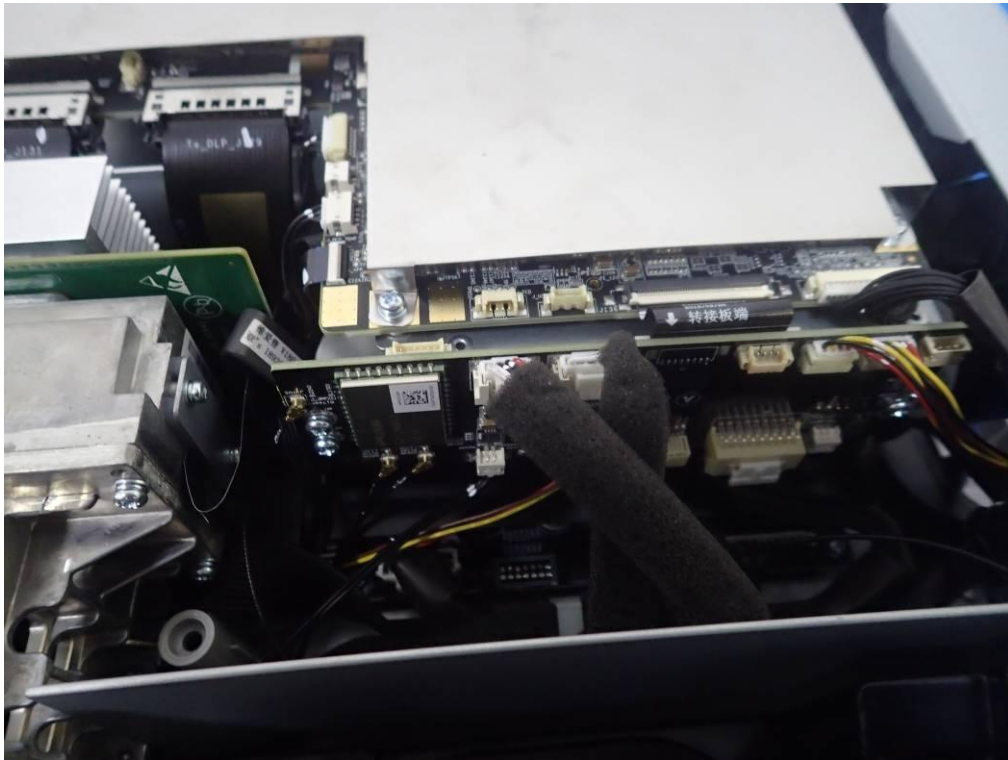

OPEN VIEW OF EUT-5(WIFI Antenna 2)





OPEN VIEW OF EUT-6(WIFI Antenna 1)



OPEN VIEW OF EUT-7(BT Antenna)

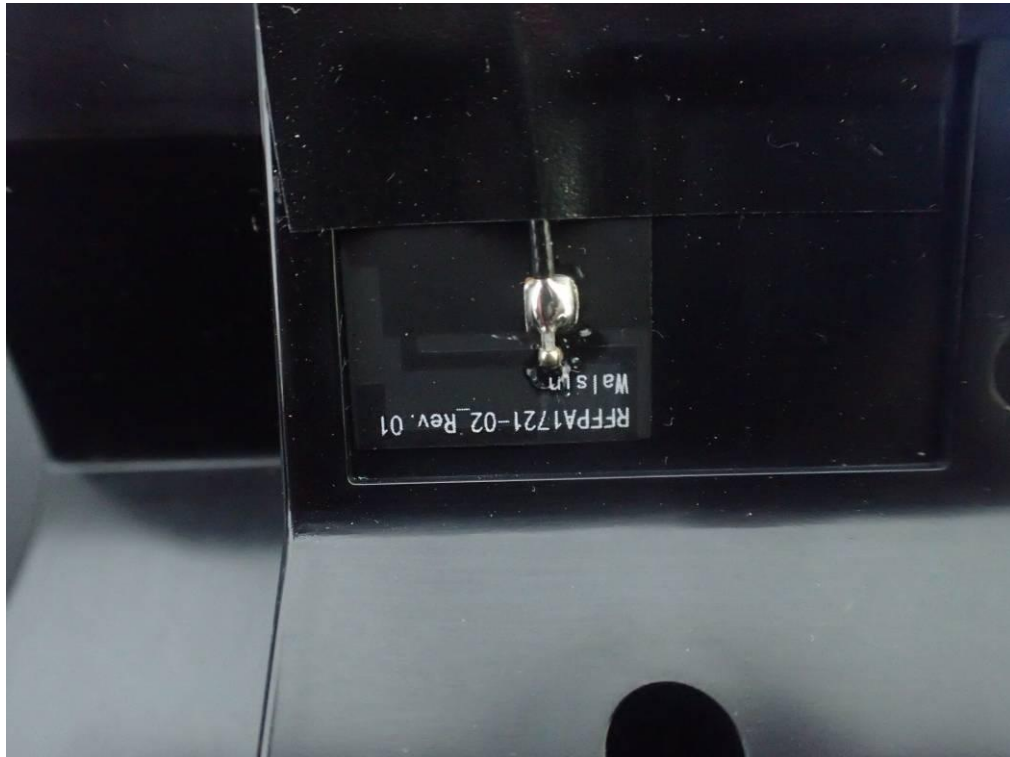

OPEN VIEW OF EUT-8

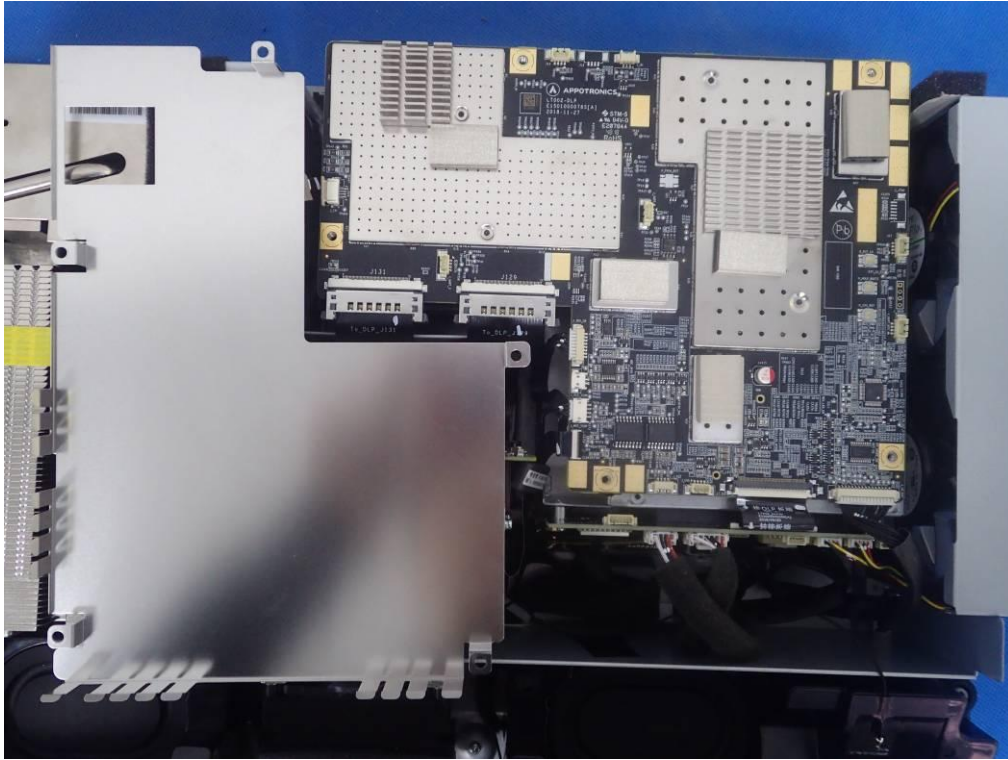

OPEN VIEW OF EUT-9

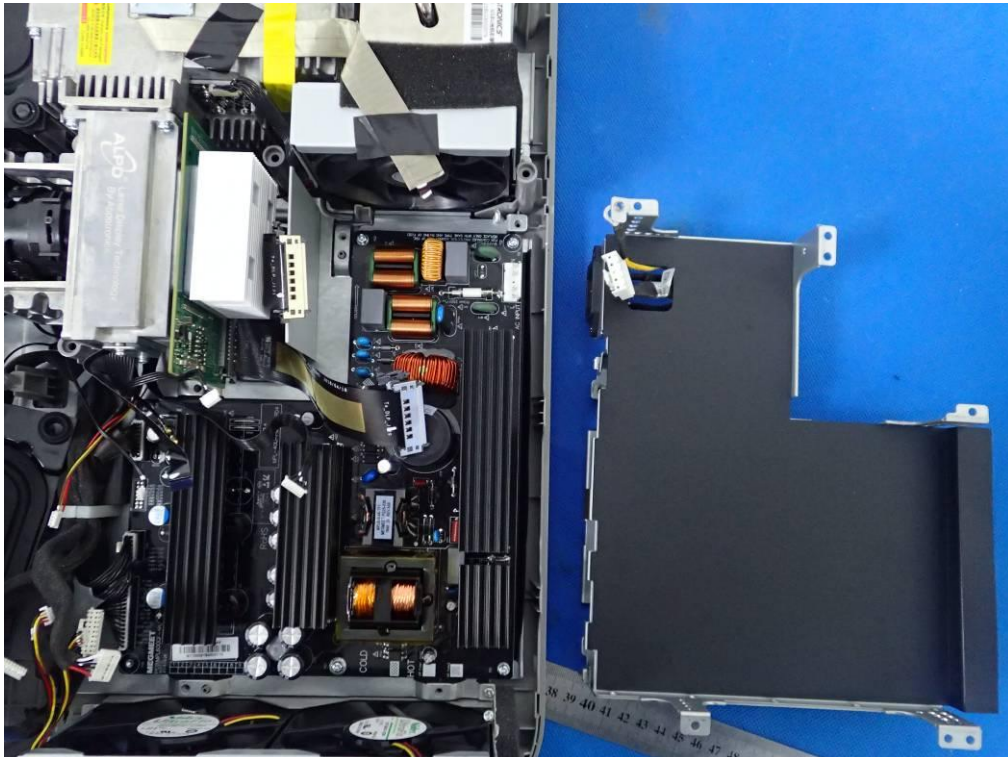

INTERNAL VIEW OF EUT-1

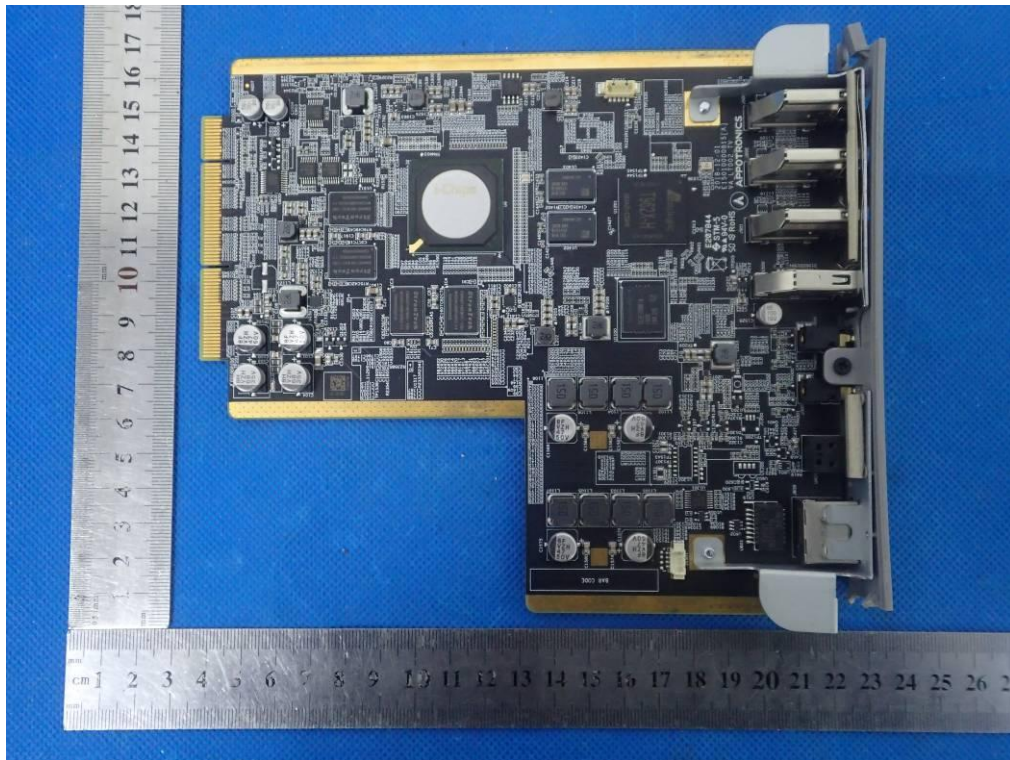

INTERNAL VIEW OF EUT-2



INTERNAL VIEW OF EUT-3

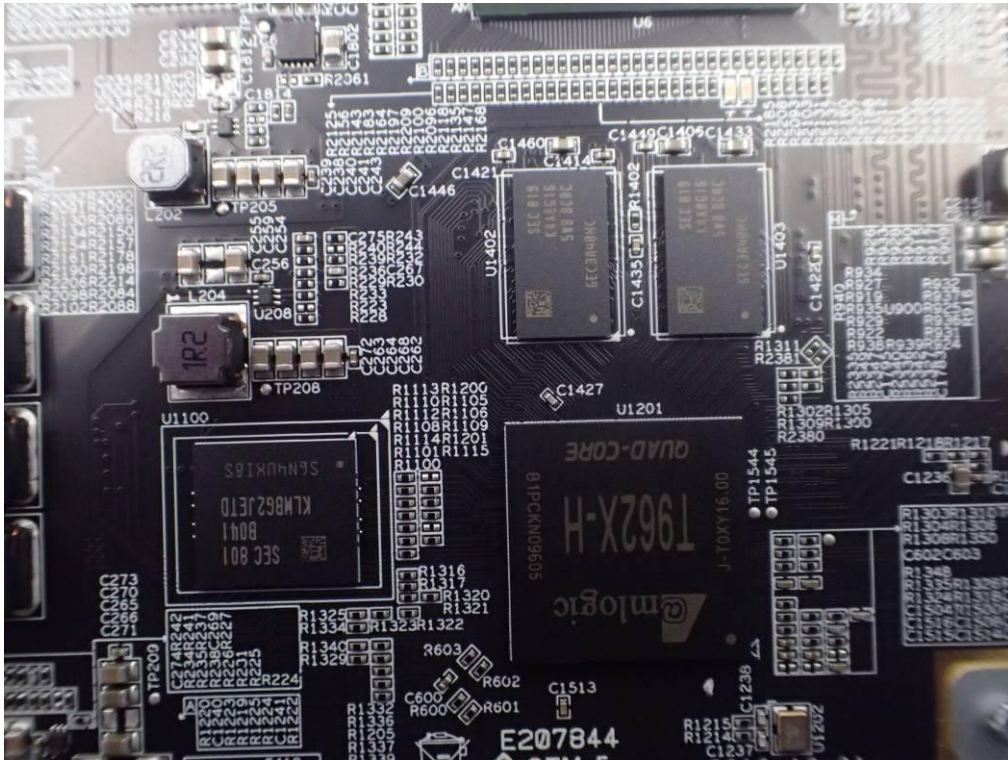

INTERNAL VIEW OF EUT-4

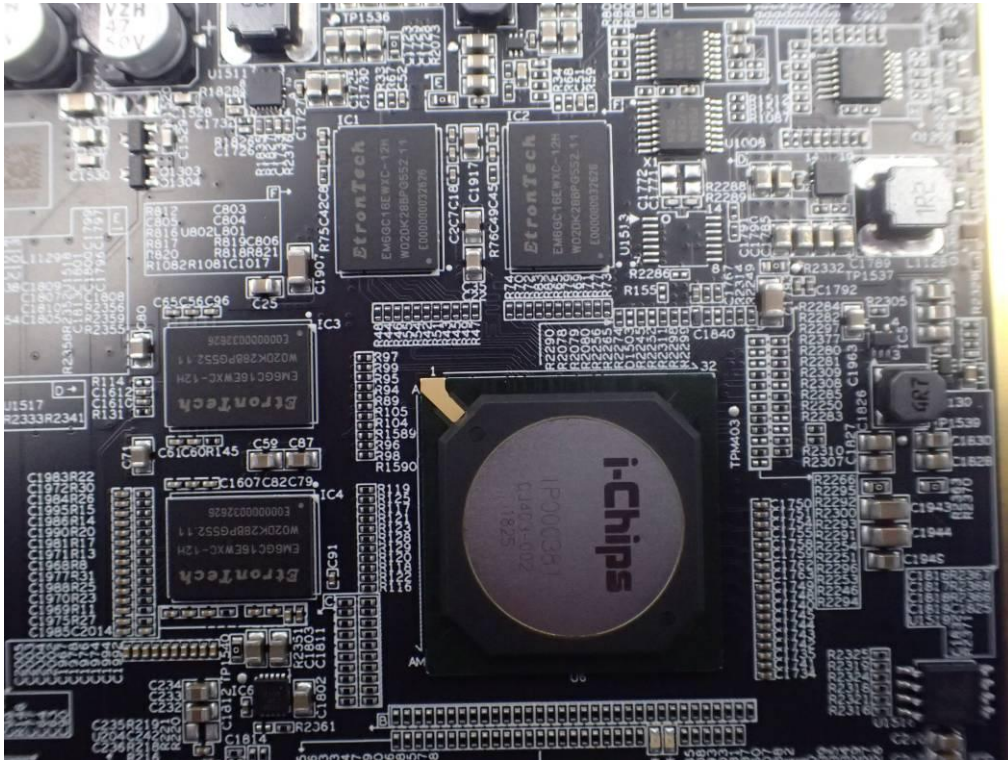

INTERNAL VIEW OF EUT-5

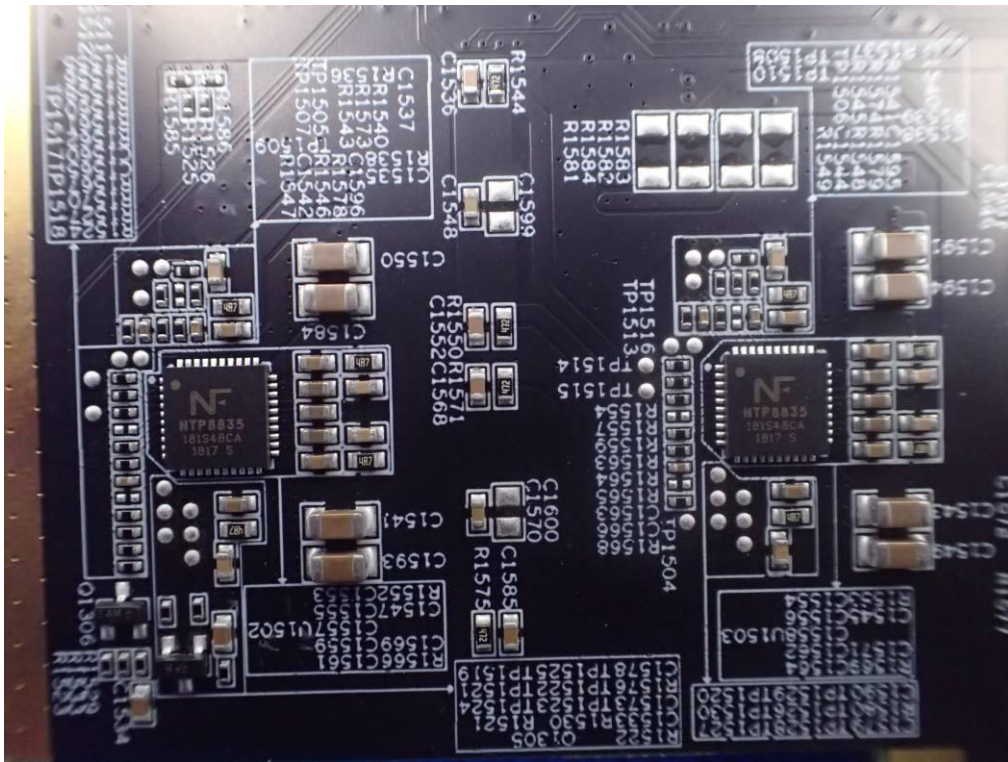

INTERNAL VIEW OF EUT-6

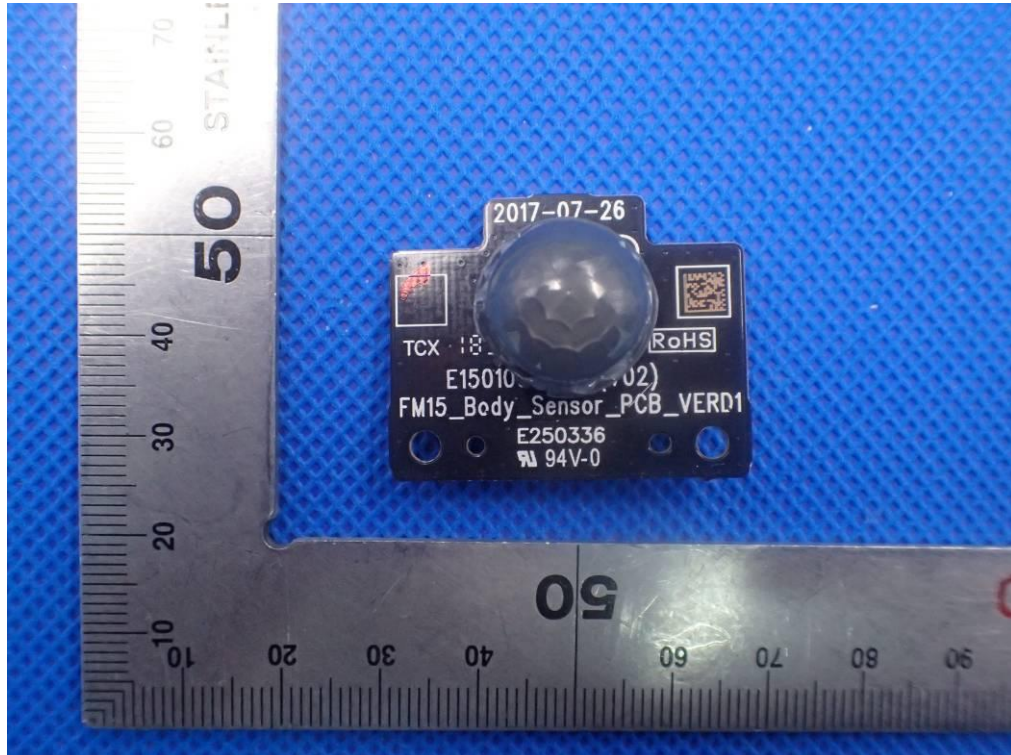



INTERNAL VIEW OF EUT-7

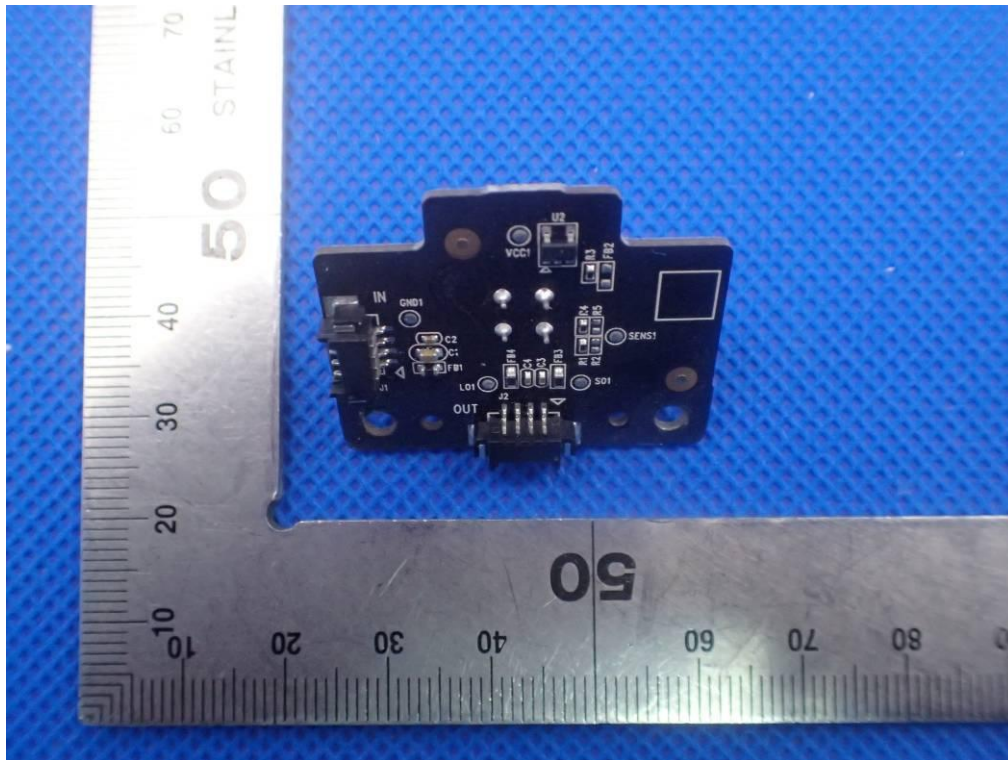

INTERNAL VIEW OF EUT-8

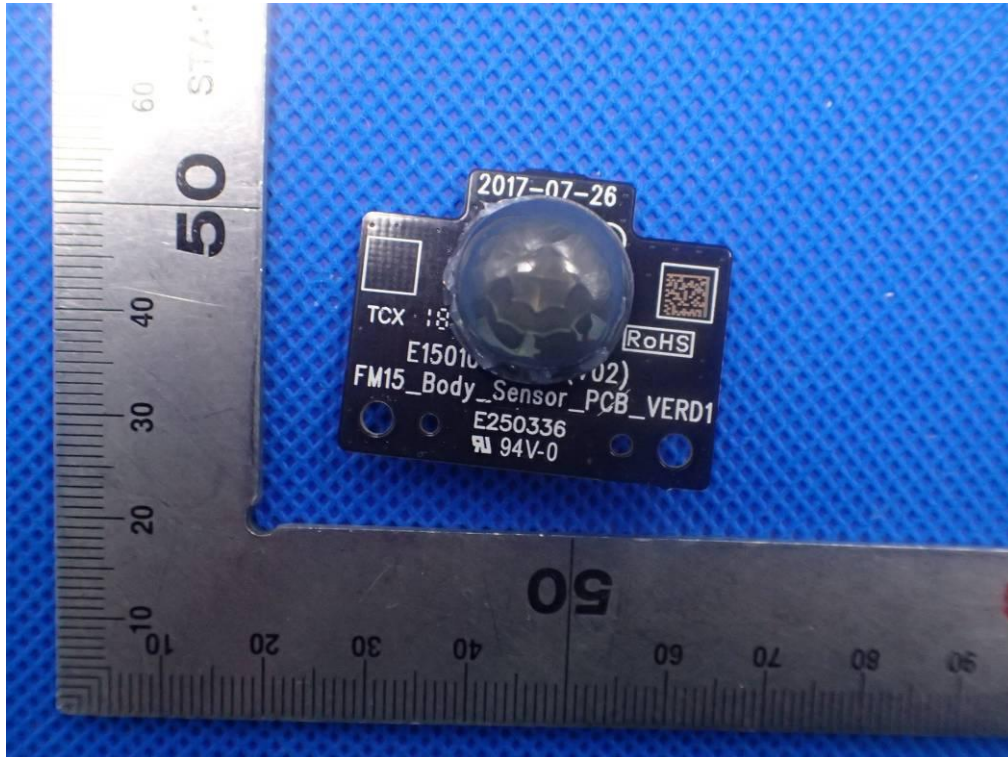

INTERNAL VIEW OF EUT-9

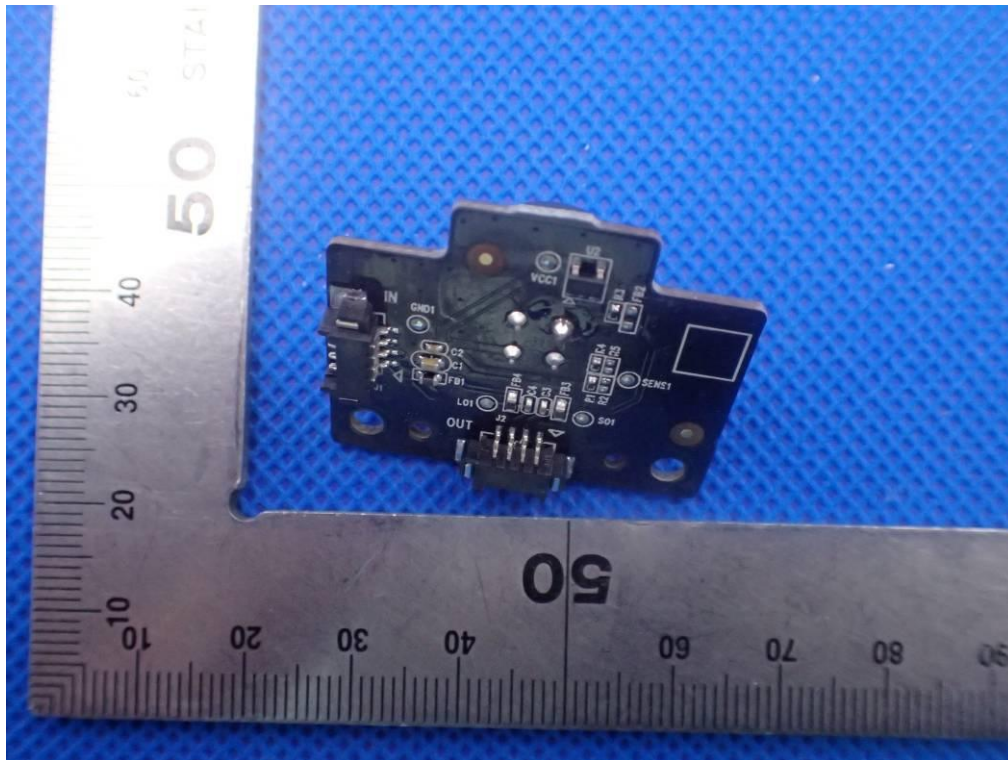

INTERNAL VIEW OF EUT-10

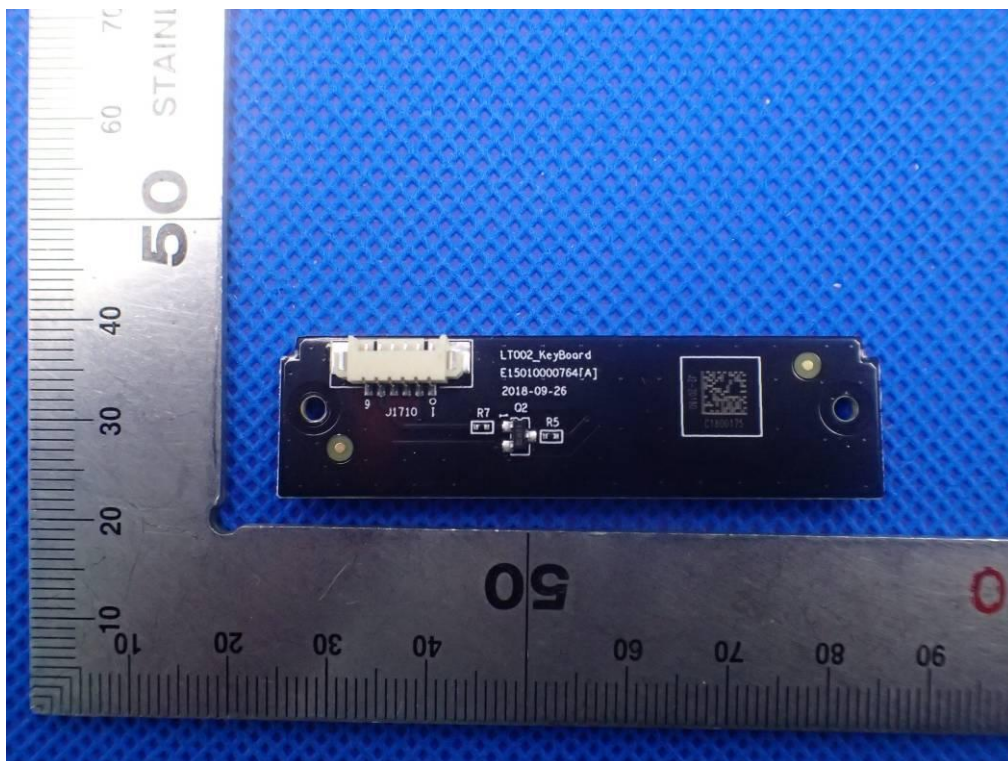

INTERNAL VIEW OF EUT-11



INTERNAL VIEW OF EUT-12

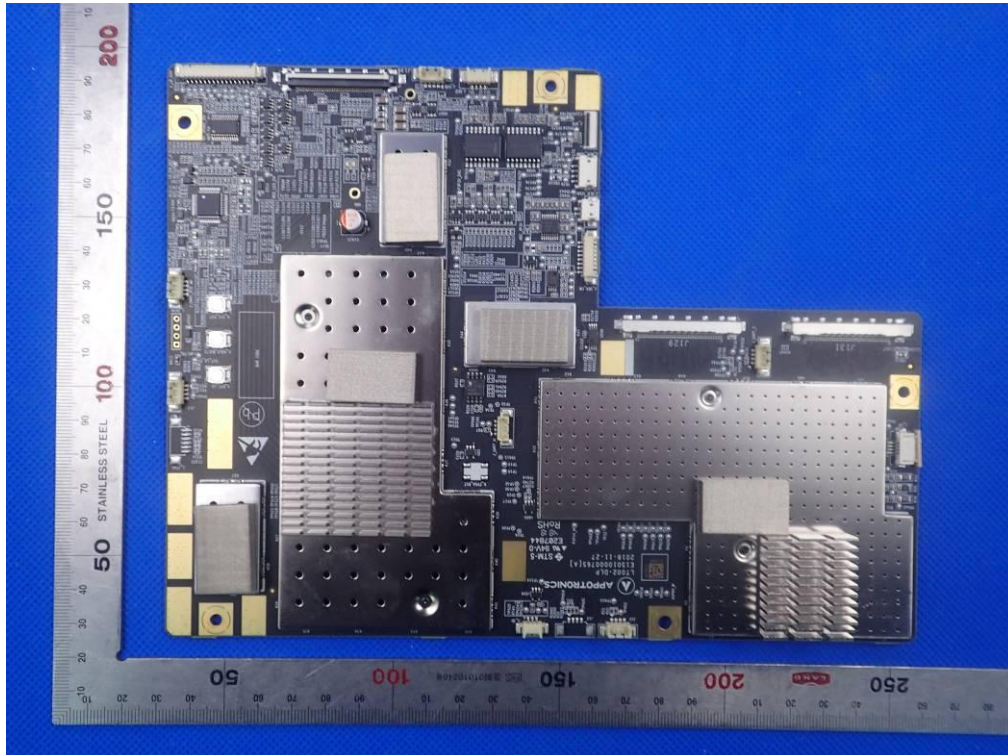

INTERNAL VIEW OF EUT-13

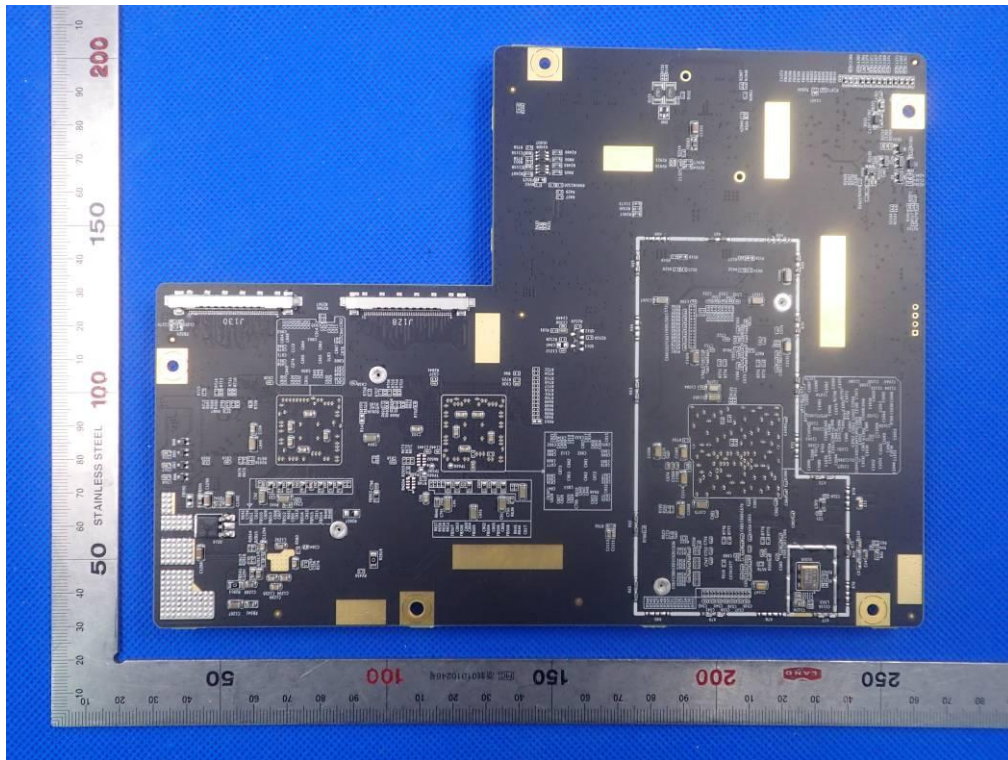

INTERNAL VIEW OF EUT-14

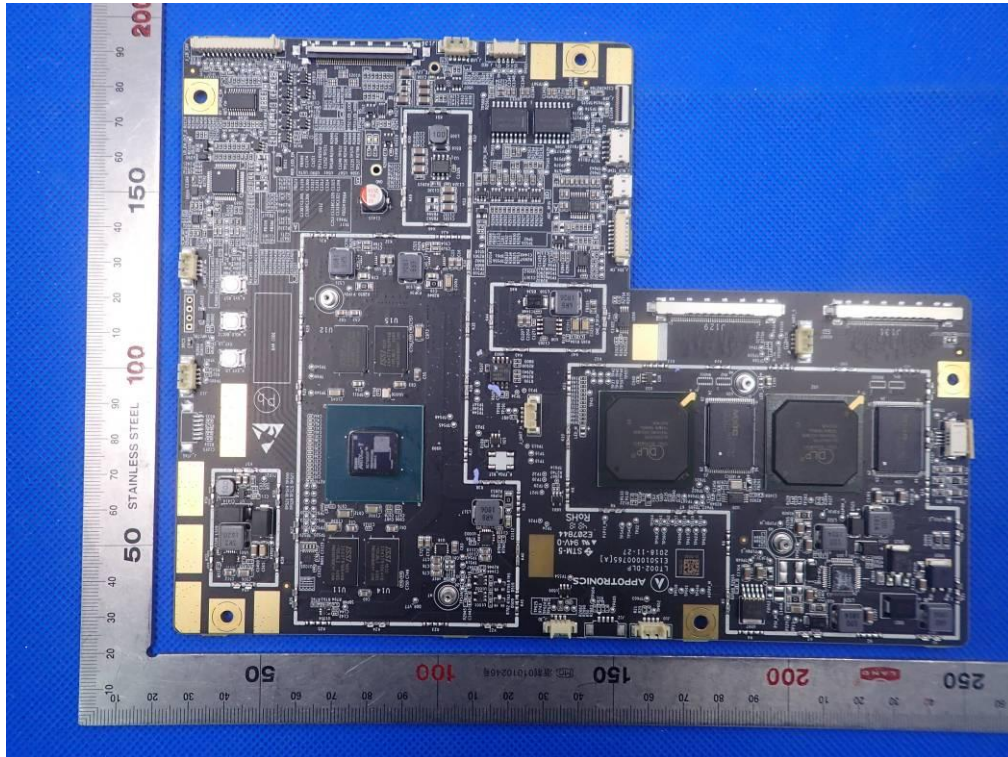

INTERNAL VIEW OF EUT-15

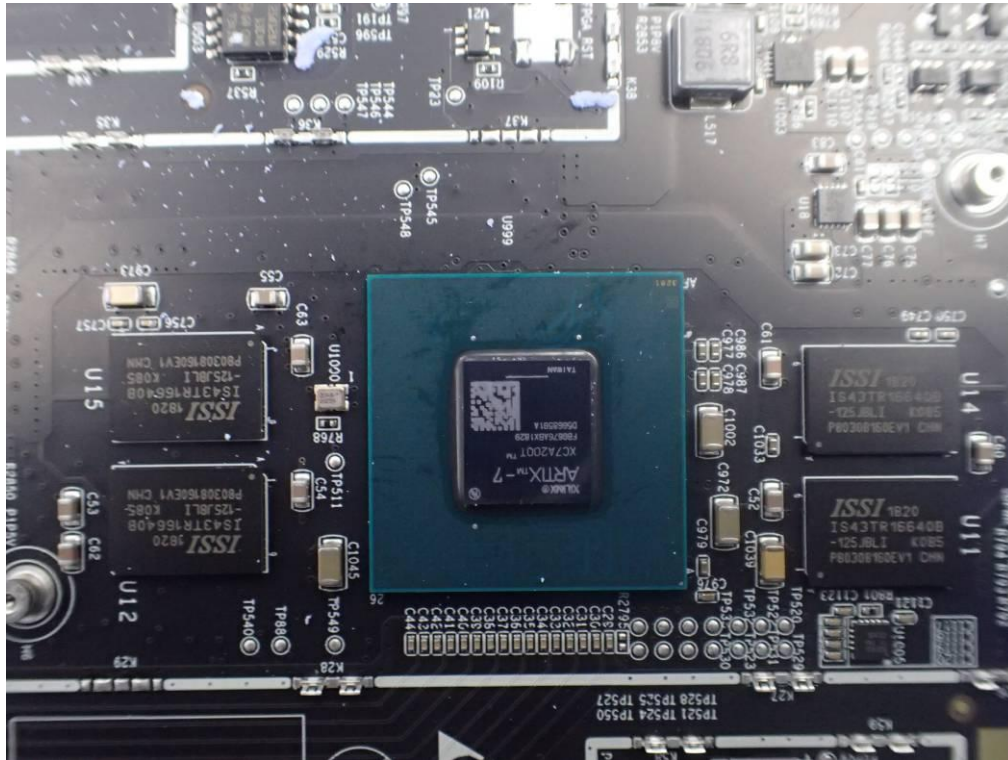

INTERNAL VIEW OF EUT-16

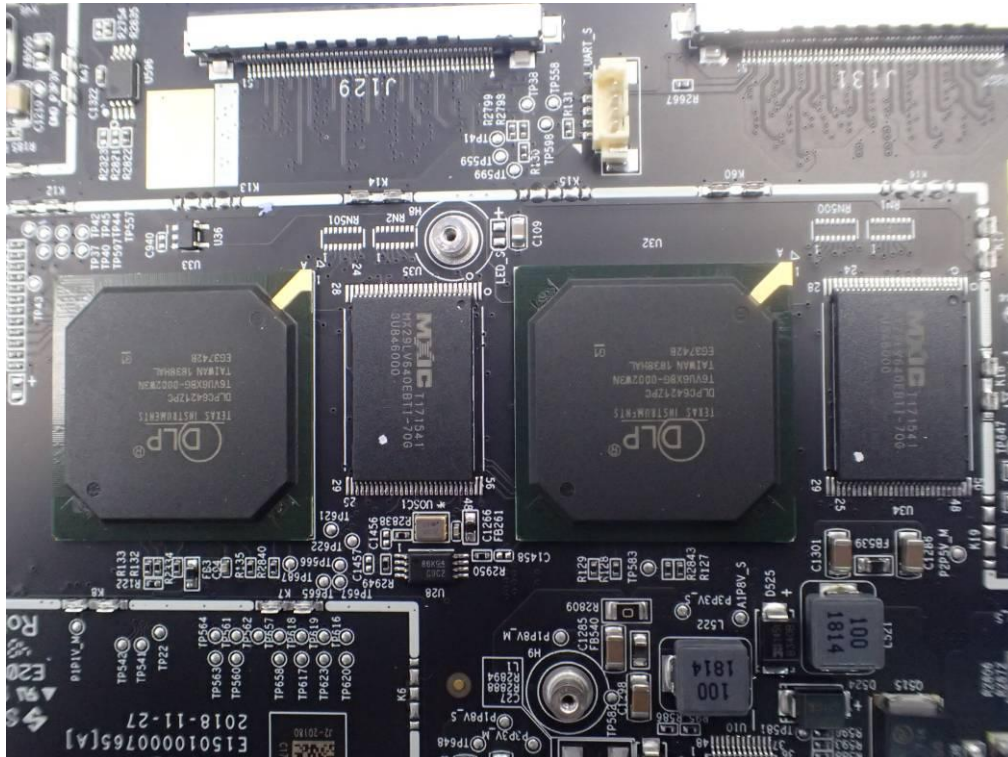

INTERNAL VIEW OF EUT-17

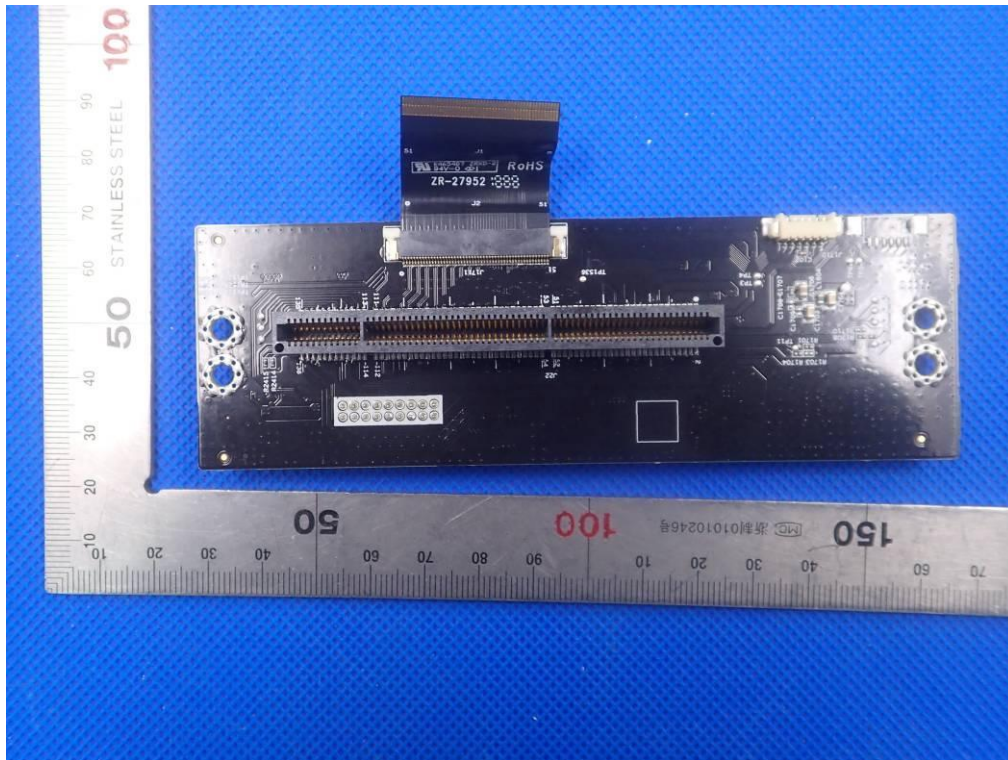

INTERNAL VIEW OF EUT-18

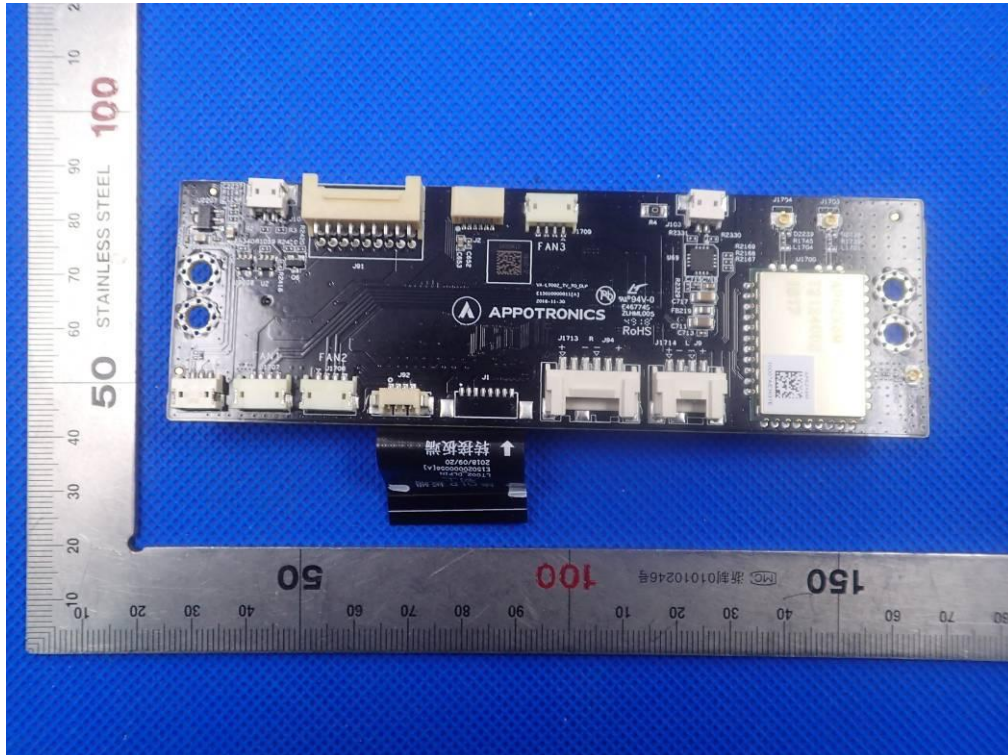

INTERNAL VIEW OF EUT-19



INTERNAL VIEW OF EUT-20

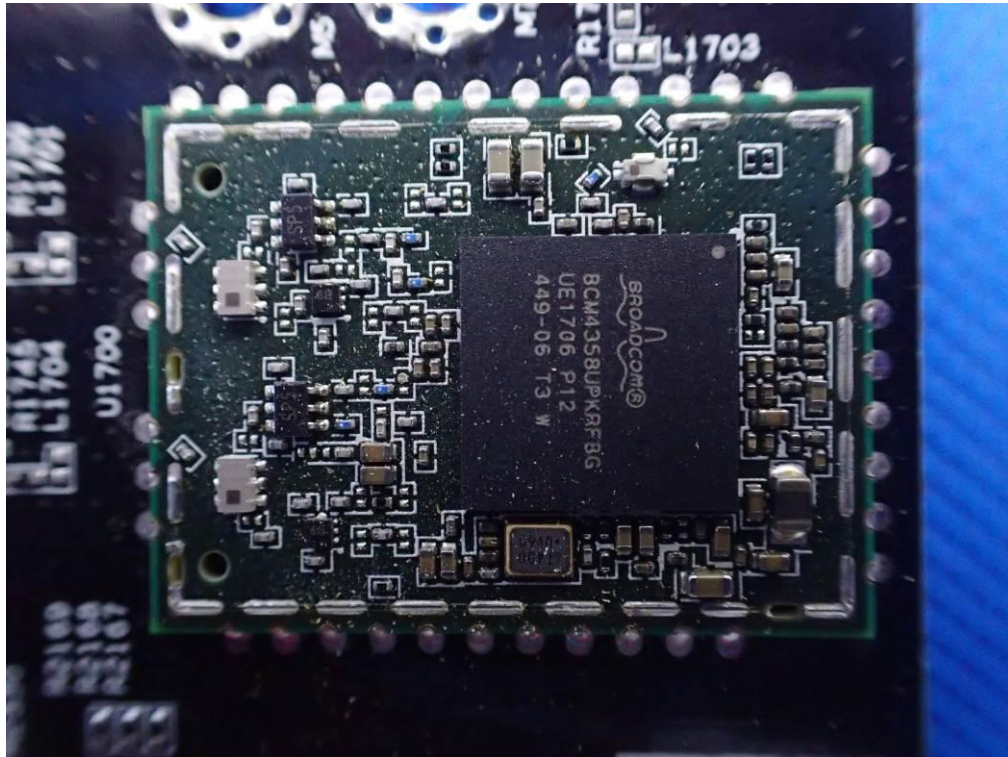

INTERNAL VIEW OF EUT-21

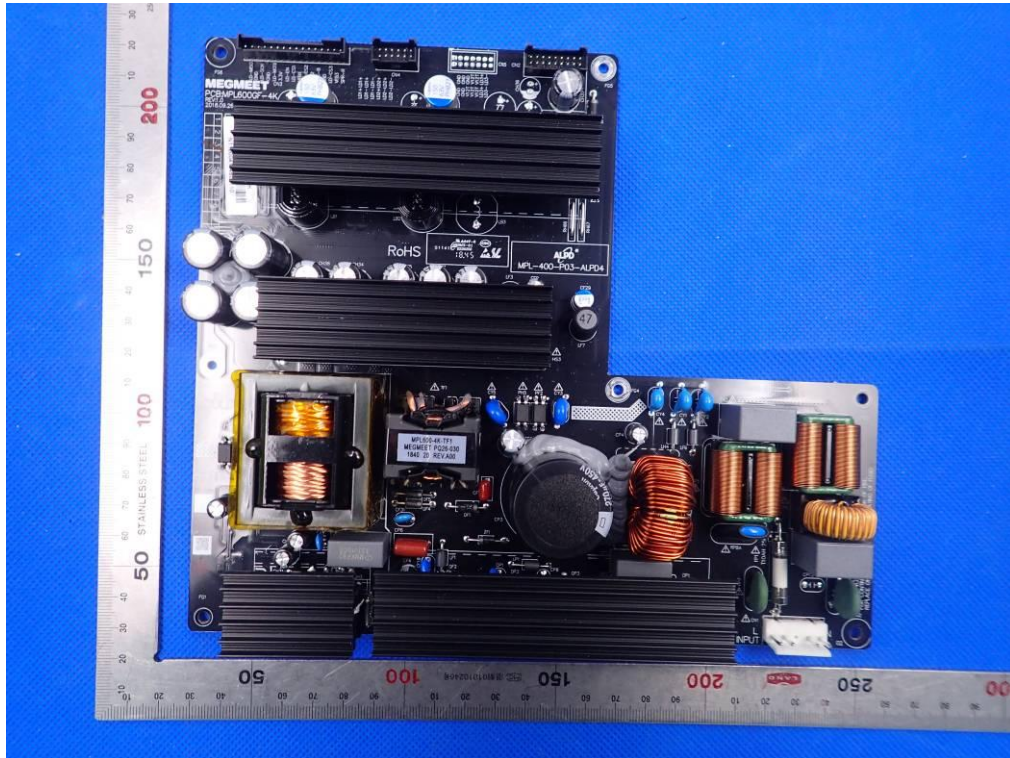

INTERNAL VIEW OF EUT-22

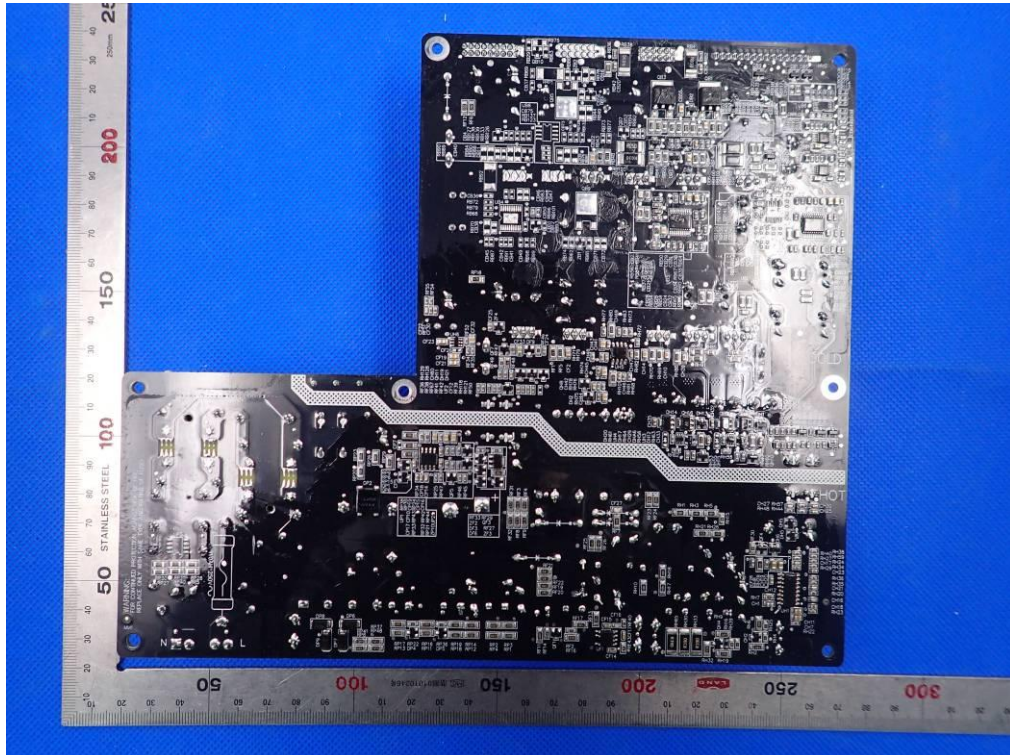

INTERNAL VIEW OF EUT-23

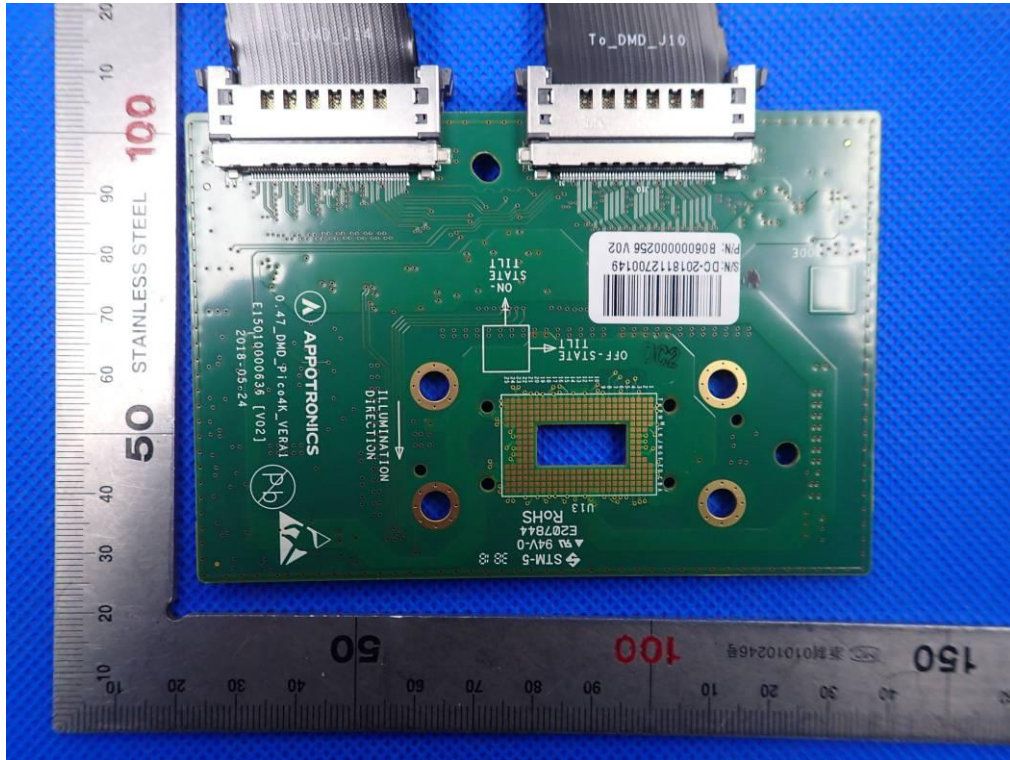

INTERNAL VIEW OF EUT-24

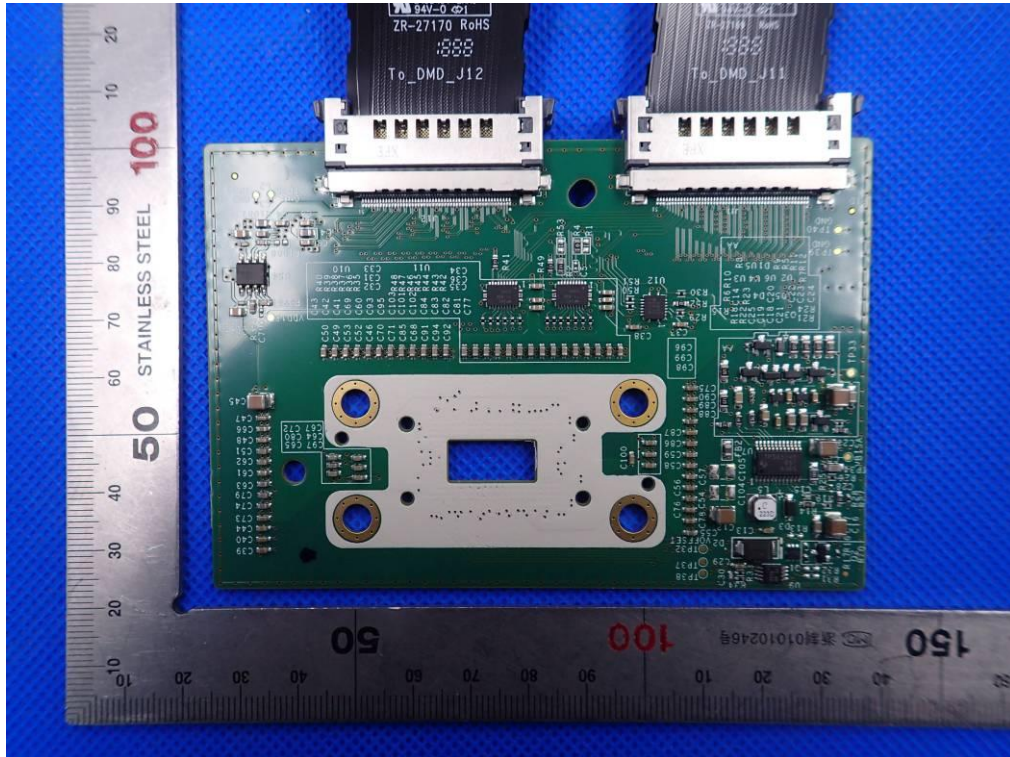



INTERNAL VIEW OF EUT-25

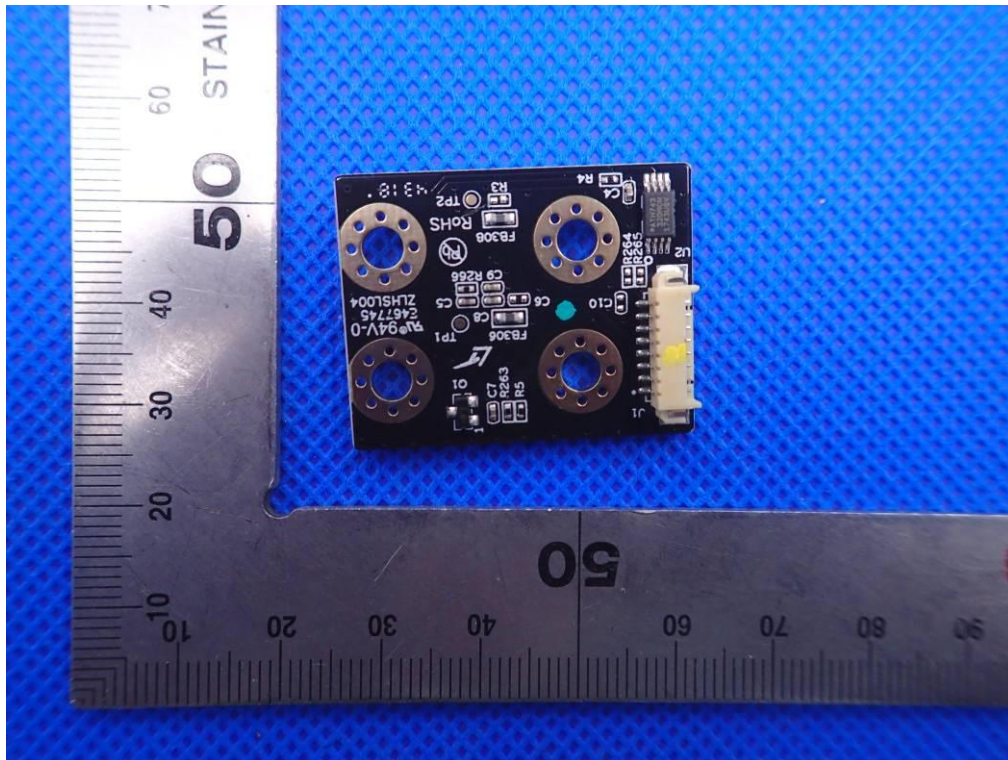

INTERNAL VIEW OF EUT-26

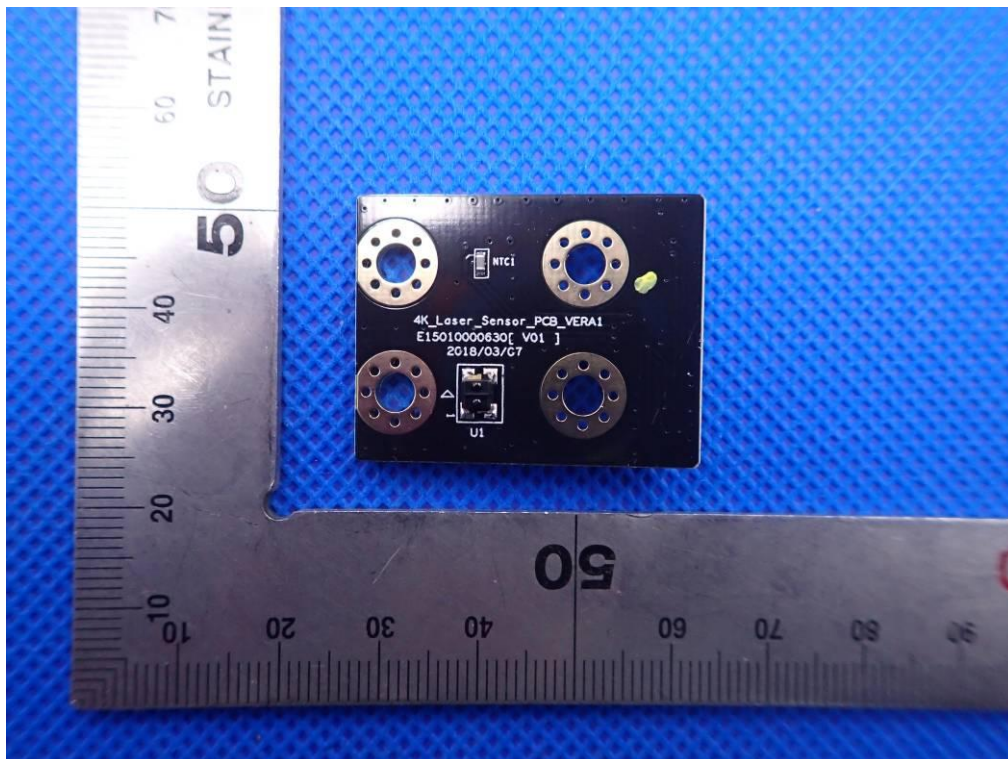

----END OF REPORT---