FCC Test Report

Report No.: AGC01892160303FE03

FCC ID : 2AFDGBAXX
APPLICATION PURPOSE : Original Equipment
PRODUCT DESIGNATION : Wireless 2-in-1 Adapter
BRAND NAME : TAOTRONICS
MODEL NAME : See Page 4
CLIENT : SUNVALLEYTEK INTERNATIONAL, INC.
DATE OF ISSUE : Mar.23,2016
STANDARD(S) : FCC Part 15 Rules
TEST PROCEDURE(S)
REPORT VERSION : V1.0

Attestation of Global Compliance (Shenzhen) Co., Ltd



CAUTION:

This report shall not be reproduced except in full without the written permission of the test laboratory and shall not be quoted out of context.



Report Revise Record

Report Version	Revise Time	Issued Date	Valid Version	Notes
V1.0	/	Mar.23,2016	Valid	Original Report

TABLE OF CONTENTS

1. VERIFICATION OF CONFORMITY	4
2. GENERAL INFORMATION	5
2.1. PRODUCT DESCRIPTION.....	5
2.2. TABLE OF CARRIER FREQUENCYS.....	5
3. MEASUREMENT UNCERTAINTY.....	7
4. DESCRIPTION OF TEST MODES.....	7
5. SYSTEM TEST CONFIGURATION	8
5.1. CONFIGURATION OF EUT SYSTEM	8
5.2. EQUIPMENT USED IN EUT SYSTEM	8
5.3. SUMMARY OF TEST RESULTS	8
6. TEST FACILITY	9
7 TEST METHODOLOGY.....	9
8. ALL TEST EQUIPMENT LIST	9
9. RADIATED EMISSION	11
9.1TEST LIMIT.....	11
9.2. MEASUREMENT PROCEDURE	12
9.3. TEST SETUP.....	14
9.4. TEST RESULT	16
10. BAND EDGE EMISSION	42
10.1. MEASUREMENT PROCEDURE	42
10.2 TEST SETUP	42
10.3 RADIATED TEST RESULT	43
11. 20DB BANDWIDTH.....	51
11.1. MEASUREMENT PROCEDURE	51
11.2. TEST SET-UP	51
11.3. LIMITS AND MEASUREMENT RESULTS	51
12. FCC LINE CONDUCTED EMISSION TEST	61
12.1. LIMITS OF LINE CONDUCTED EMISSION TEST	61
12.2. BLOCK DIAGRAM OF LINE CONDUCTED EMISSION TEST	61
12.3. PRELIMINARY PROCEDURE OF LINE CONDUCTED EMISSION TEST	62
12.4. FINAL PROCEDURE OF LINE CONDUCTED EMISSION TEST	62
12.5. TEST RESULT OF LINE CONDUCTED EMISSION TEST	63
APPENDIX A: PHOTOGRAPHS OF TEST SETUP	67
APPENDIX B: PHOTOGRAPHS OF EUT	69

1. VERIFICATION OF CONFORMITY

Applicant	SUNVALLEYTEK INTERNATIONAL, INC.
Address	46724 Lakeview Blvd, Fremont, CA 94538-6529,United States
Manufacturer	Shenzhen NearbyExpress Technology Development Company Limited
Address	2F, Block D, Minle Industrial Park, Meiban Road, Longhua District, Shenzhen, China. 518131
Product Designation	Wireless 2-in-1 Adapter
Brand Name	TAOTRONICS
Test Model	TT-BA07
Series Model	TT-BA08, TT-BA09, TT-BA10, TT-BA11, TT-BA12
Difference description	All the same except the model name and appearance color
Date of test	Mar.07,2016 to Mar.09,2016
Deviation	None
Condition of Test Sample	Normal
Report Template	AGCRT-US-BR/RF

We hereby certify that:

The above equipment was tested by Dongguan Precise Testing Service Co., Ltd. The test data, the energy emitted by the sample tested as described in this report is in compliance with the requirements of FCC Rules Part 15.249.

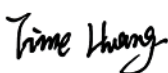

Tested By Time Huang(Huang Nanhui) Mar.23,2016



Reviewed By Forrest Lei(Lei Yonggang) Mar.23,2016



Approved By Solger Zhang(Zhang Hongyi) Mar.23,2016
Authorized Officer

2. GENERAL INFORMATION

2.1. PRODUCT DESCRIPTION

A major technical description of EUT is described as following

Operation Frequency	2.402 GHz to 2.480GHz
RF Output Power	3.52dBm(Max)
Bluetooth Version	V4.1
Modulation	GFSK, $\pi/4$ -DQPSK, 8DPSK
Number of channels	79 for BR/EDR, 40 for BLE
Hardware Version	V003
Software Version	V003
Antenna Designation	PCB Antenna
Antenna Gain	1dBi
Power Supply	DC 3.7V by battery

Note: The USB port only used for charging and can't be used to transfer data with PC.

2.2. TABLE OF CARRIER FREQUENCIES

BR/EDR channel List

Frequency Band	Channel Number	Frequency
2400~2483.5MHZ	0	2402MHZ
	1	2403MHZ
	:	:
	38	2440 MHZ
	39	2441 MHZ
	40	2442 MHZ
	:	:
	77	2479 MHZ
	78	2480 MHZ

BLE Channel List

Frequency Band	Channel Number	Frequency
2400~2483.5MHZ	0	2402MHZ
	1	2404MHZ
	:	:
	38	2478 MHZ
	39	2480 MHZ

3. MEASUREMENT UNCERTAINTY

The reported uncertainty of measurement $y \pm U$, where expanded uncertainty U is based on a standard uncertainty multiplied by a coverage factor of $k=2$, providing a level of confidence of approximately 95 %.

No.	Item	Uncertainty
1	Conducted Emission Test	± 3.18 dB
2	All emissions, radiated	± 3.91 dB
3	Temperature	± 0.5 °C
4	Humidity	± 2 %

4. DESCRIPTION OF TEST MODES

NO.	TEST MODE DESCRIPTION
1	Low channel GFSK
2	Middle channel GFSK
3	High channel GFSK
4	Low channel $\pi/4$ -DQPSK
5	Middle channel $\pi/4$ -DQPSK
6	High channel $\pi/4$ -DQPSK
7	Low channel 8DPSK
8	Middle channel 8DPSK
9	High channel 8DPSK
10	TX with charging + phone
11	RX with charging + earphone

Note:

1. All the test modes can be supply by battery, only the result of the worst case was recorded in the report, if no other cases.
2. For Radiated Emission, 3axis were chosen for testing for each applicable mode.
3. The EUT used fully-charged battery when tested.

5. SYSTEM TEST CONFIGURATION

5.1. CONFIGURATION OF EUT SYSTEM

Configure 1: (Normal hopping)

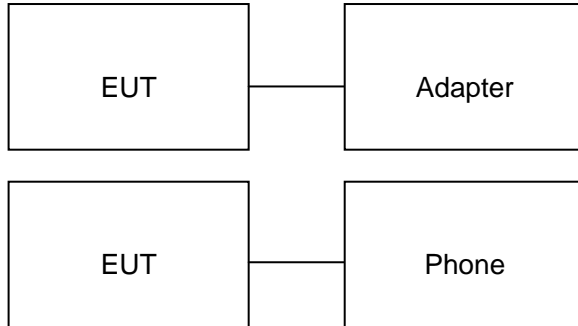

Configure 2: (Control continuous TX)

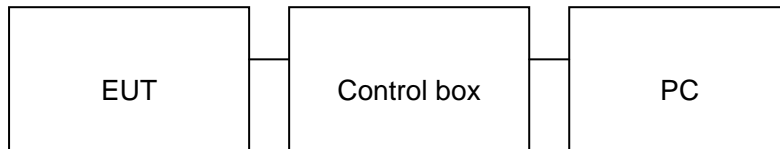

5.2. EQUIPMENT USED IN EUT SYSTEM

Item	Equipment	Model No.	ID or Specification	Remark
1	Bluetooth Adapter	TAOTRONICS	TT-BA07	EUT
2	PC	SONY	E1412AYCW	A.E
3	Control box	N/A	N/A	A.E
4	AC adapter	ETPCA-050100U3W	--	A.E
5	Temporary Antenna Connector	T10	N/A	A.E

5.3. SUMMARY OF TEST RESULTS

FCC RULES	DESCRIPTION OF TEST	RESULT
§15.249	Radiated Emission	Compliant
§15.249	Band Edges	Compliant
§15.207	Conduction Emission	Compliant
§15.215	BANDWIDTH	Compliant

6. TEST FACILITY

Site	Dongguan Precise Testing Service Co., Ltd.
Location	Building D, Baoding Technology Park, Guangming Road2, Dongcheng District, Dongguan, Guangdong, China,
FCC Registration No.	371540
Description	The test site is constructed and calibrated to meet the FCC requirements in documents ANSI C63.10:2013

7 TEST METHODOLOGY

All measurements contained in this report were conducted with ANSI C63.10-2013.

8. ALL TEST EQUIPMENT LIST

FOR RADIATED EMISSION TEST (BELOW 1GHZ)

Radiated Emission Test Site					
Name of Equipment	Manufacturer	Model Number	Serial Number	Last Calibration	Due Calibration
EMI Test Receiver	Rohde & Schwarz	ESCI	101417	July 4, 2015	July 3, 2016
Trilog Broadband Antenna (25M-1GHz)	SCHWARZBECK	VULB9160	9160-3355	July 4, 2015	July 3, 2016
Signal Amplifier	SCHWARZBECK	BBV 9475	9745-0013	July 4, 2015	July 3, 2016
RF Cable	SCHWARZBECK	AK9515E	96221	July 4, 2015	July 3, 2016
3m Anechoic Chamber	CHENGYU	966	PTS-001	June 6, 2015	June 5, 2016
MULTI-DEVICE Positioning Controller	Max-Full	MF-7802	MF780208339	N/A	N/A
Active loop antenna (9K-30MHz)	Schwarzbeck	FMZB1519	1519-038	June 6, 2015	June 5, 2016
Spectrum analyzer	Agilent	E4407B	MY46185649	June 6, 2015	June 5, 2016
Radiation Cable 1	MXT	RS1	R005	June 6, 2015	June 5, 2016
Radiation Cable 2	MXT	RS1	R006	June 6, 2015	June 5, 2016

FOR RADIATED EMISSION TEST (1GHZ ABOVE)

Radiated Emission Test Site					
Name of Equipment	Manufacturer	Model Number	Serial Number	Last Calibration	Due Calibration
EMI Test Receiver	Rohde & Schwarz	ESCI	101417	July 4, 2015	July 3, 2016
Horn Antenna (1G-18GHz)	SCHWARZBECK	BBHA9120D	9120D-1246	July 11, 2015	July 10, 2016
Spectrum Analyzer	Agilent	E4411B	MY4511453	July 4, 2015	July 3, 2016
Signal Amplifier	SCHWARZBECK	BBV 9718	9718-269	July 7, 2015	July 6, 2016
RF Cable	SCHWARZBECK	AK9515H	96220	July 8, 2015	July 7, 2016
3m Anechoic Chamber	CHENGYU	966	PTS-001	June 6, 2015	June 5, 2016
MULTI-DEVICE Positioning Controller	Max-Full	MF-7802	MF780208339	N/A	N/A
Horn Ant (18G-40GHz)	Schwarzbeck	BBHA 9170	9170-181	June 6, 2015	June 5, 2016
Radiation Cable 1	MXT	RS1	R005	June 6, 2015	June 5, 2016
Radiation Cable 2	MXT	RS1	R006	June 6, 2015	June 5, 2016

Conducted Emission Test Site					
Name of Equipment	Manufacturer	Model Number	Serial Number	Last Calibration	Due Calibration
EMI Test Receiver	- Rohde & Schwarz	ESCI	101417	July 4, 2015	July 3, 2016
Artificial Mains Network	Narda	L2-16B	000WX31025	July 8, 2015	July 7, 2016
Artificial Mains Network (AUX)	Narda	L2-16B	000WX31026	July 8, 2015	July 7, 2016
RF Cable	SCHWARZBECK	AK9515E	96222	July 4, 2015	July 3, 2016
Shielded Room	CHENGYU	843	PTS-002	June 6,2015	June 5,2016
Conduction Cable	MXT	SE1	S003	June 6,2015	June 5,2016

9. RADIATED EMISSION

9.1 TEST LIMIT

Standard FCC15.249

Fundamental Frequency	Field Strength of Fundamental (millivolts/meter)	Field Strength of Harmonics (microvolts/meter)
900-928MHz	50	500
2400-2483.5MHz	50	500
5725-5875MHz	50	500
24.0-24.25GHz	250	2500

Standard FCC 15.209

Frequency (MHz)	Distance Meters	Field Strengths Limit	
		μ V/m	dB(μ V)/m
0.009 ~ 0.490	300	2400/F(kHz)	---
0.490 ~ 1.705	30	24000/F(kHz)	---
1.705 ~ 30	30	30	---
30 ~ 88	3	100	40.0
88 ~ 216	3	150	43.5
216 ~ 960	3	200	46.0
960 ~ 1000	3	500	54.0
Above 1000	3	Other:74.0 dB(μ V)/m (Peak) 54.0 dB(μ V)/m (Average)	

Remark: (1) Emission level $\text{dB}\mu\text{V} = 20 \log \text{Emission level } \mu\text{V/m}$
(2) The smaller limit shall apply at the cross point between two frequency bands.
(3) Distance is the distance in meters between the measuring instrument, antenna and the closest point of any part of the device or system.

9.2. MEASUREMENT PROCEDURE

1. The EUT was placed on the top of the turntable 0.8 meter above ground. The phase center of the receiving antenna mounted on the top of a height-variable antenna tower was placed 3 meters far away from the turntable.
2. Power on the EUT and all the supporting units. The turntable was rotated by 360 degrees to determine the position of the highest radiation.
3. The height of the broadband receiving antenna was varied between one meter and four meters above ground to find the maximum emissions field strength of both horizontal and vertical polarization.
4. For each suspected emissions, the antenna tower was scan (from 1 M to 4 M) and then the turntable was rotated (from 0 degree to 360 degrees) to find the maximum reading.
5. Set the test-receiver system to Peak or CISPR quasi-peak Detect Function with specified bandwidth under Maximum Hold Mode.
6. For emissions above 1GHz, use 1.5MHz VBW and RBW for peak reading. Then 1.5MHz RBW and 10Hz VBW for average reading in spectrum analyzer.

Place the measurement antenna away from each area of the EUT determined to be a source of emissions at the specified measurement distance, while keeping the measurement antenna aimed at the source of emissions at each frequency of significant emissions, with polarization oriented for maximum response. The measurement antenna may have to be higher or lower than the EUT, depending on the radiation pattern of the emission and staying aimed at the emission source for receiving the maximum signal. The final measurement antenna elevation shall be that which maximizes the emissions. The measurement antenna elevation for maximum emissions shall be restricted to a range of heights of from 1 m to 4 m above the ground or reference ground plane.

7. When the radiated emissions limits are expressed in terms of the average value of the emissions, and pulsed operation is employed, the measurement field strength shall be determined by averaging over one complete pulse train, including blanking intervals, as long as the pulse train does not exceed 0.1 seconds. As an alternative (provided the transmitter operates for longer than 0.1 seconds) or in cases where the pulse train exceeds 0.1 seconds, the measured field strength shall be determined from the average absolute voltage during a 0.1 second interval during which the field strength is at its maximum values.
8. If the emissions level of the EUT in peak mode was 3 dB lower than the average limit specified, then testing will be stopped and peak values of EUT will be reported, otherwise, the emissions which do not have 3 dB margin will be repeated one by one using the quasi-peak method for below 1GHz.
9. For testing above 1GHz, the emissions level of the EUT in peak mode was lower than average limit (that means the emissions level in peak mode also complies with the limit in average mode), then testing will be stopped and peak values of EUT will be reported, otherwise, the emissions will be measured in average mode again and reported.
10. In case the emission is lower than 30MHz, loop antenna has to be used for measurement and the recorded data should be QP measured by receiver. High - Low scan is not required in this case.

The following table is the setting of spectrum analyzer and receiver.

Spectrum Parameter	Setting
Start ~Stop Frequency	9KHz~150KHz/RB 200Hz for QP
Start ~Stop Frequency	150KHz~30MHz/RB 9KHz for QP
Start ~Stop Frequency	30MHz~1000MHz/RB 120KHz for QP
Start ~Stop Frequency	1GHz~26.5GHz 1.5MHz/1.5MHz for Peak, 1.5MHz/10Hz for Average

Receiver Parameter	Setting
Start ~Stop Frequency	9KHz~150KHz/RB 200Hz for QP
Start ~Stop Frequency	150KHz~30MHz/RB 9KHz for QP
Start ~Stop Frequency	30MHz~1000MHz/RB 120KHz for QP

9.3. TEST SETUP

Radiated Emission Test-Setup Frequency Below 30MHz

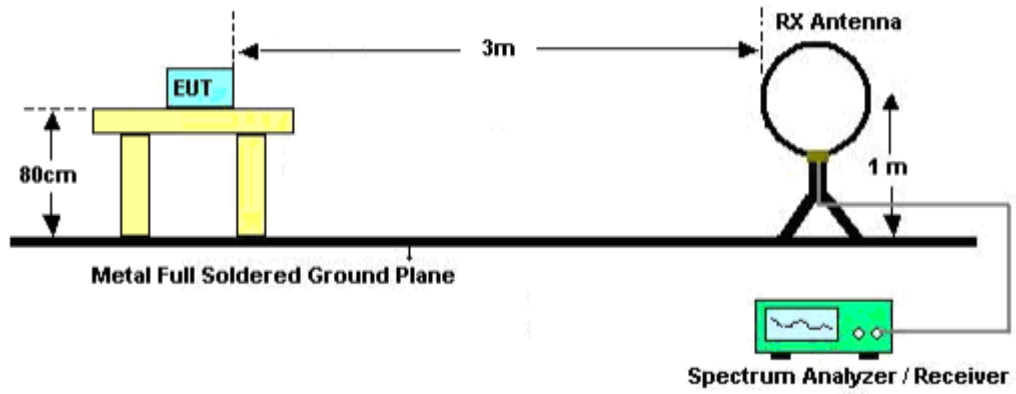

RADIATED EMISSION TEST SETUP 30MHz-1000MHz

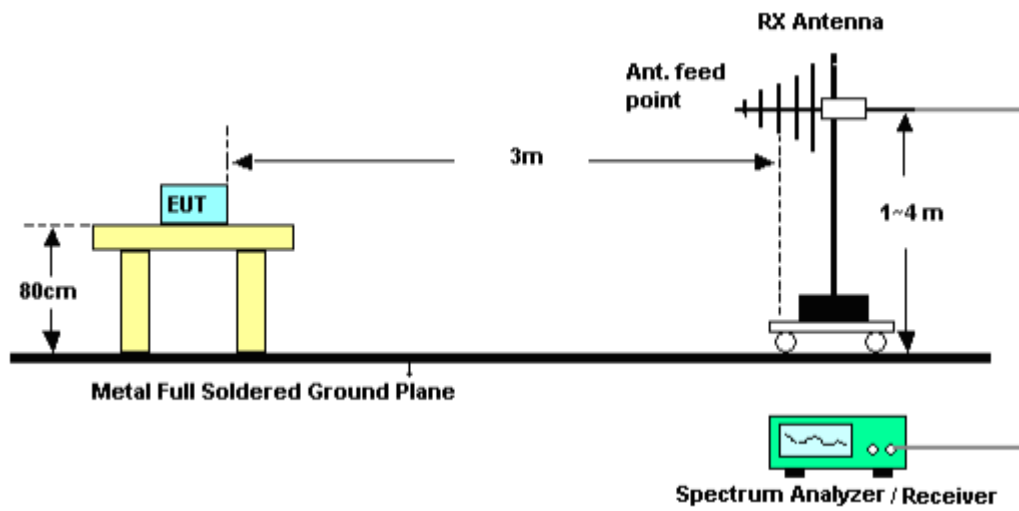

RADIATED EMISSION TEST SETUP ABOVE 1000MHz

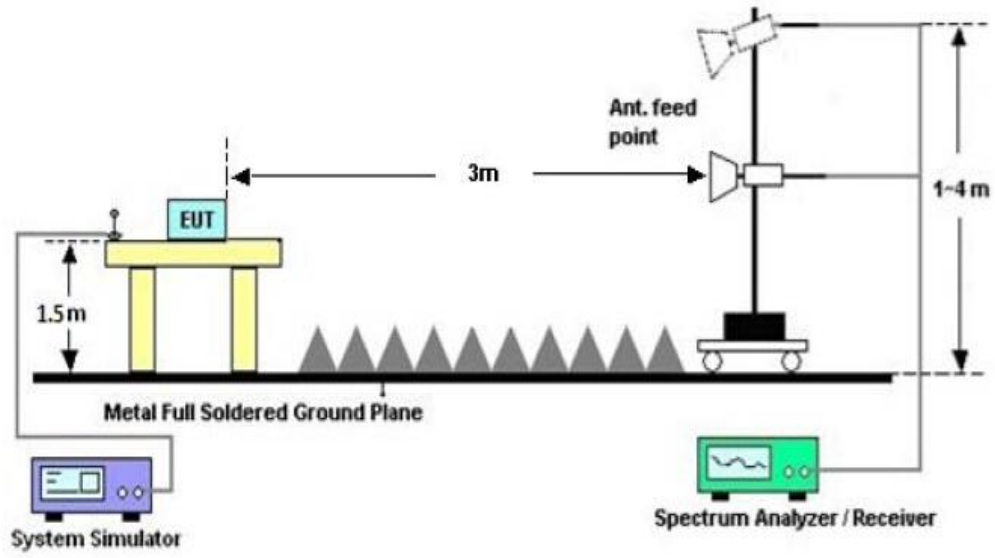

9.4. TEST RESULT

(Worst modulation: GFSK)

FOR BR/EDR

RADIATED EMISSION BELOW 30MHz Wireless 2-in-1 Adapter

No emission found between lowest internal used/generated frequencies to 30MHz.

RADIATED EMISSION BELOW 1GHZ

RADIATED EMISSION TEST- (30MHz-1GHz)-LOW CHANNEL-HORIZONTAL



Site: site #1	Polarization: <i>Horizontal</i>	Temperature: 22.8
Limit: FCC Class B 3M Radiation	Power:	Humidity: 54.2 %
EUT: Wireless 2-in-1 Adapter	Distance:	
M/N: TT-BA07		
Mode: Low Channel TX		
Note:		

No.	Mk	Freq.	Reading	Factor	Measurement	Limit	Over	Detector	Antenna Height	Table Degree	Comment
		MHz	dBuV	dB/m	dBuV/m	dBuV/m	dB		cm	degree	
1	!	52.6333	25.95	8.41	34.36	40.00	-5.64	peak			
2		136.7000	20.03	13.66	33.69	43.50	-9.81	peak			
3		201.3667	21.42	11.86	33.28	43.50	-10.22	peak			
4		301.6000	23.92	15.52	39.44	46.00	-6.56	peak			
5	*	351.7167	24.00	18.75	42.75	46.00	-3.25	peak			
6		898.1500	8.39	28.56	36.95	46.00	-9.05	peak			

RESULT: PASS

RADIATED EMISSION TEST- (30MHZ-1GHZ)-LOW CHANNEL -VERTICAL

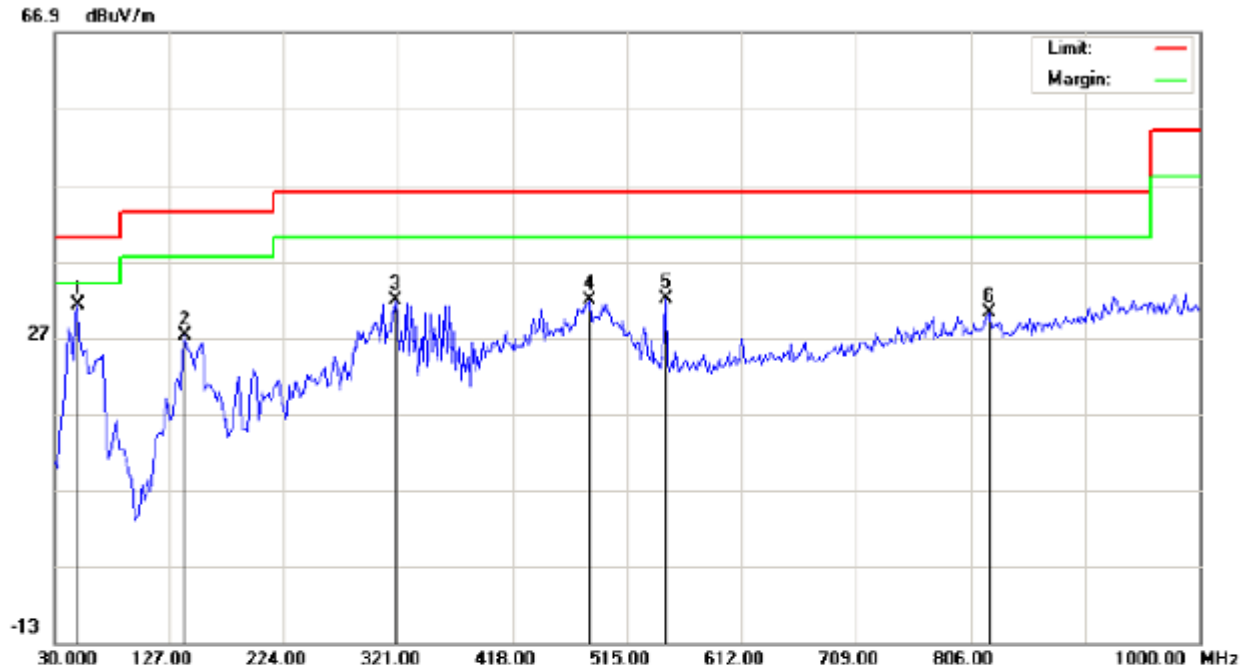

Site: site #1
Limit: FCC Class B 3M Radiation
EUT: Wireless 2-in-1 Adapter
M/N: TT-BA07
Mode: Low Channel TX
Note:

Polarization: *Vertical*
Power:
Distance:

Temperature: 22.8
Humidity: 54.2 %

No.	Mk	Freq.	Reading	Factor	Measurement	Limit	Over	Detector	Antenna Height	Table Degree	Comment
		MHz	dBuV	dB/m	dBuV/m	dBuV/m	dB		cm	degree	
1	*	49.4000	22.94	8.28	31.22	40.00	-8.78	peak			
2		139.9333	12.05	15.17	27.22	43.50	-16.28	peak			
3		319.3833	15.16	16.70	31.86	46.00	-14.14	peak			
4		482.6667	10.95	20.94	31.89	46.00	-14.11	peak			
5		547.3333	9.53	22.41	31.94	46.00	-14.06	peak			
6		822.1667	2.79	27.32	30.11	46.00	-15.89	peak			

RESULT: PASS

Note: 1. Factor=Antenna Factor + Cable loss, Margin=Measurement-Limit.

2. The "Factor" value can be calculated automatically by software of measurement system.

RADIATED EMISSION TEST- (30MHZ-1GHZ)-MIDDLE CHANNEL-HORIZONTAL



Site: site #1
Limit: FCC Class B 3M Radiation
EUT: Wireless 2-in-1 Adapter
M/N: TT-BA07
Mode: Middle Channel TX
Note:

Polarization: *Horizontal*
Power:
Distance:

Temperature: 22.8
Humidity: 54.2 %

No.	Mk	Freq.	Reading	Factor	Measurement	Limit	Over	Detector	Antenna Height	Table Degree	Comment
		MHz	dBuV	dB/m	dBuV/m	dBuV/m	dB		cm	degree	
1		52.6333	25.08	8.41	33.49	40.00	-6.51	peak			
2		136.7000	19.56	13.66	33.22	43.50	-10.28	peak			
3		201.3667	21.64	11.86	33.50	43.50	-10.00	peak			
4	*	299.9833	27.01	15.41	42.42	46.00	-3.58	peak			
5		343.6333	21.60	18.32	39.92	46.00	-6.08	peak			
6		877.1333	2.78	28.02	30.80	46.00	-15.20	peak			

RESULT: PASS

RADIATED EMISSION TEST- (30MHZ-1GHZ)- MIDDLE CHANNEL -VERTICAL

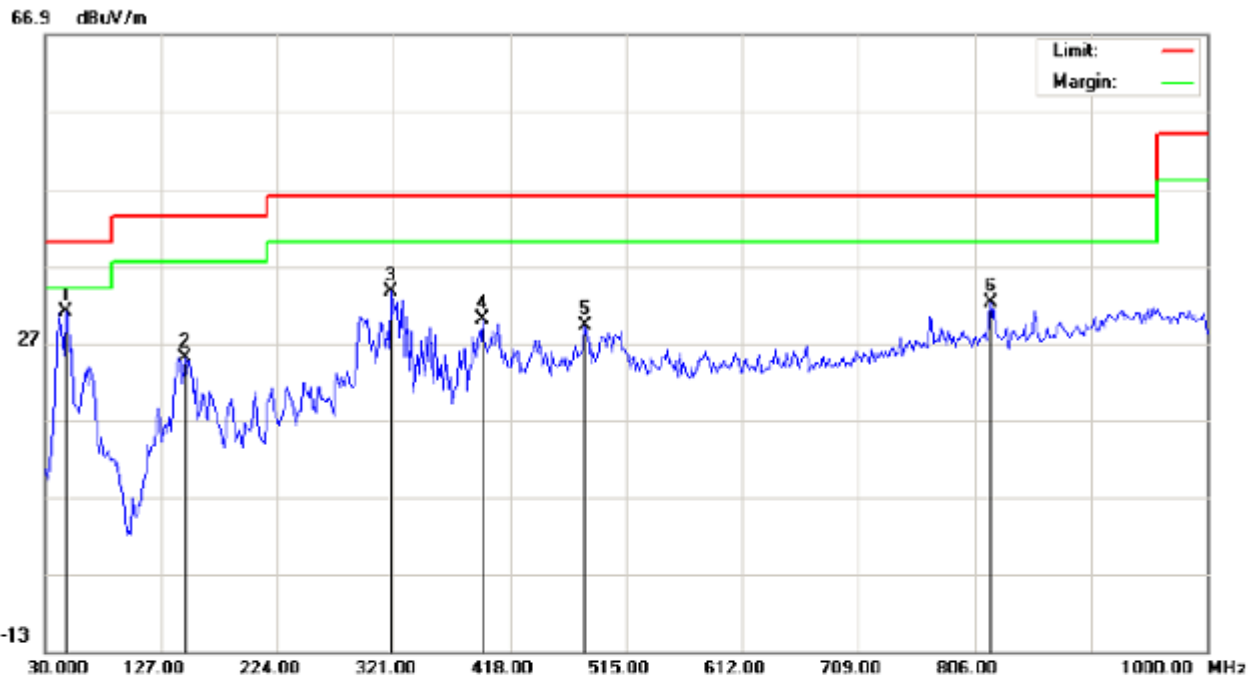

Site: site #1
Limit: FCC Class B 3M Radiation
EUT: Wireless 2-in-1 Adapter
M/N: TT-BA07
Mode: Middle Channel TX
Note:

Polarization: **Vertical**
Power:
Distance:

Temperature: 22.8
Humidity: 54.2 %

No.	Mk	Freq.	Reading	Factor	Measurement	Limit	Over	Detector	Antenna	Table	Comment
		MHz	dBuV	dB/m	dBuV/m	dBuV/m	dB		Height	Degree	
									cm	degree	
1	*	47.7833	22.54	8.39	30.93	40.00	-9.07	peak			
2		146.4000	9.86	15.24	25.10	43.50	-18.40	peak			
3		319.3833	16.86	16.70	33.56	46.00	-12.44	peak			
4		395.3667	10.94	19.04	29.98	46.00	-16.02	peak			
5		481.0500	8.30	20.93	29.23	46.00	-16.77	peak			
6		818.9333	4.91	27.32	32.23	46.00	-13.77	peak			

RESULT: PASS

Note: 1. Factor=Antenna Factor + Cable loss, Margin=Measurement-Limit.

2. The "Factor" value can be calculated automatically by software of measurement system.

RADIATED EMISSION TEST- (30MHZ-1GHZ)-HIGH CHANNEL-HORIZONTAL

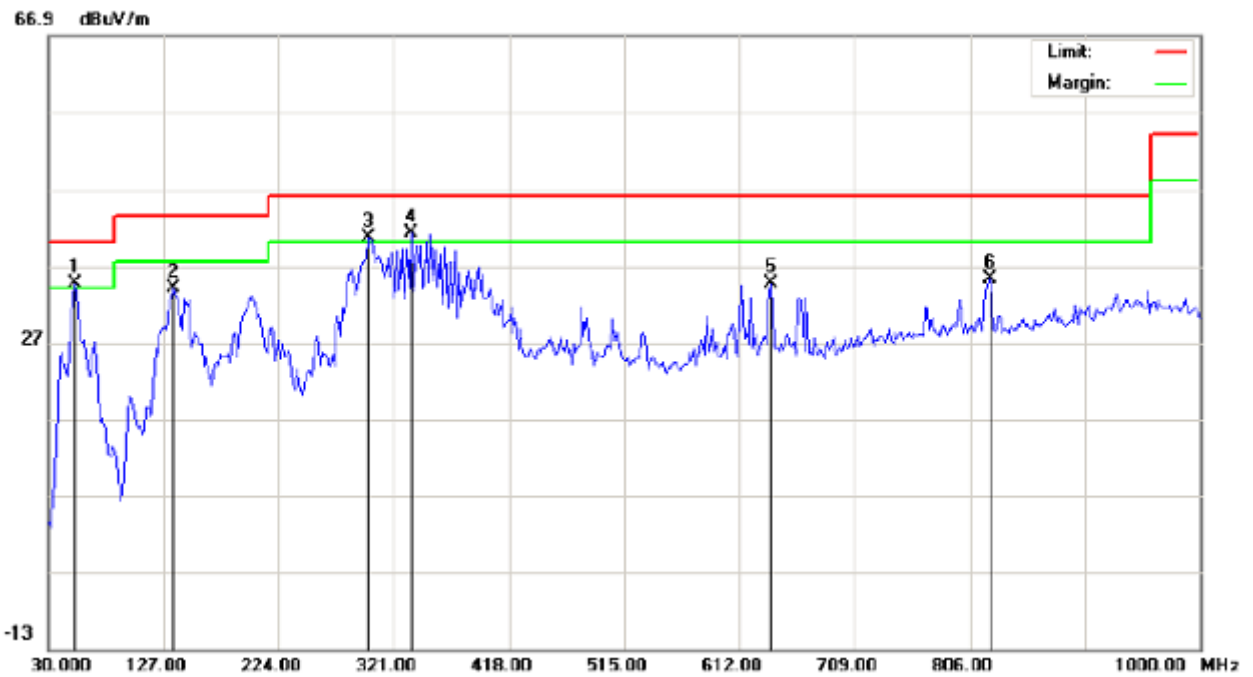

Site: site #1
Limit: FCC Class B 3M Radiation
EUT: Wireless 2-in-1 Adapter
M/N: TT-BA07
Mode: High Channel TX
Note:

Polarization: *Horizontal*
Power:
Distance:

Temperature: 22.8
Humidity: 54.2 %

No.	Mk	Freq.	Reading	Factor	Measurement	Limit	Over	Detector	Antenna Height	Table Degree	Comment
		MHz	dBuV	dB/m	dBuV/m	dBuV/m	dB		cm	degree	
1	!	52.6333	26.21	8.41	34.62	40.00	-5.38	peak			
2		135.0833	21.08	12.90	33.98	43.50	-9.52	peak			
3	!	299.9833	25.13	15.41	40.54	46.00	-5.46	peak			
4	*	335.5500	23.48	17.78	41.26	46.00	-4.74	peak			
5		637.8667	10.77	23.82	34.59	46.00	-11.41	peak			
6		823.7833	7.91	27.32	35.23	46.00	-10.77	peak			

RESULT: PASS

RADIATED EMISSION TEST- (30MHZ-1GHZ)-HIGH CHANNEL -VERTICAL

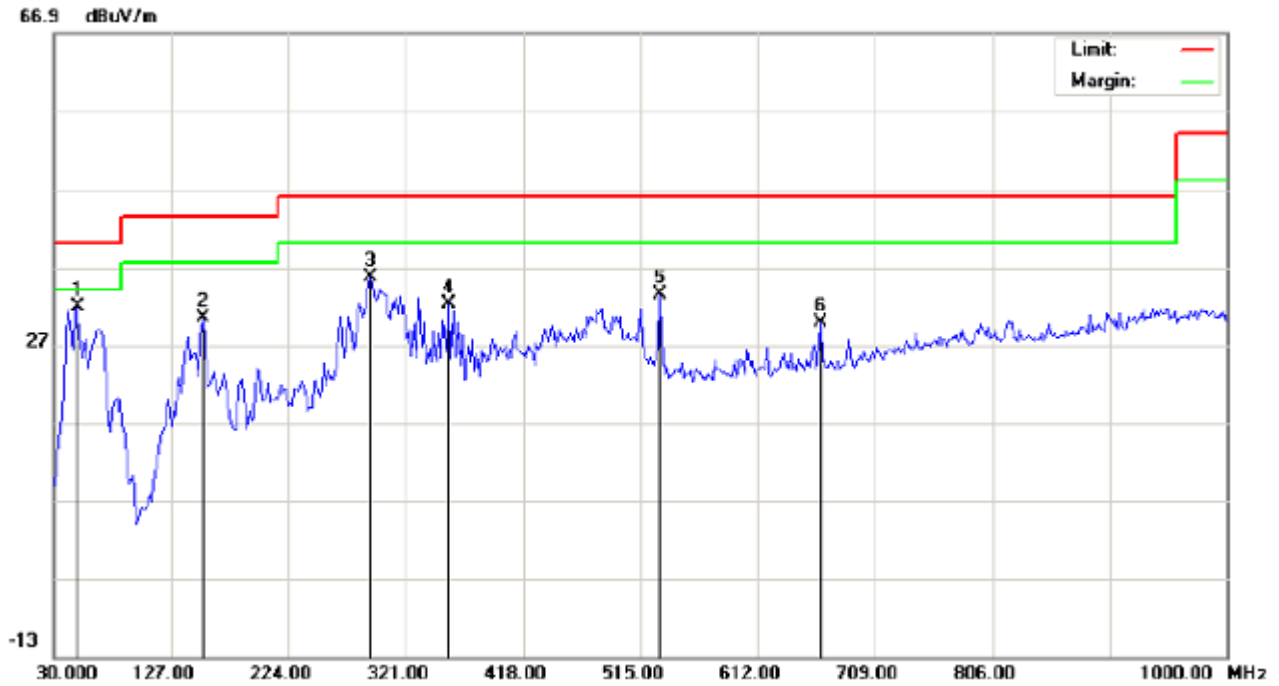

Site: site #1
Limit: FCC Class B 3M Radiation
EUT: Wireless 2-in-1 Adapter
M/N: TT-BA07
Mode: High Channel TX
Note:

Polarization: *Vertical*
Power:
Distance:

Temperature: 22.8
Humidity: 54.2 %

No.	Mk	Freq.	Reading	Factor	Measurement	Limit	Over	Detector	Antenna	Table	Comment
		MHz	dBuV	dB/m	dBuV/m	dBuV/m	dB		Height	Degree	
									cm	degree	
1	*	49.4000	23.62	8.28	31.90	40.00	-8.10	peak			
2		152.8667	15.10	15.28	30.38	43.50	-13.12	peak			
3		291.9000	20.45	15.17	35.62	46.00	-10.38	peak			
4		356.5667	13.48	18.78	32.26	46.00	-13.74	peak			
5		531.1667	11.42	21.97	33.39	46.00	-12.61	peak			
6		663.7333	5.54	24.22	29.76	46.00	-16.24	peak			

RESULT: PASS

Note: 1. Factor=Antenna Factor + Cable loss, Margin=Measurement-Limit.

2. The "Factor" value can be calculated automatically by software of measurement system.

FOR BLE

RADIATED EMISSION BELOW 30MHZ

No emission found between lowest internal used/generated frequencies to 30MHz.

RADIATED EMISSION BELOW 1GHZ

RADIATED EMISSION TEST- (30MHZ-1GHZ)-LOW CHANNEL-HORIZONTAL

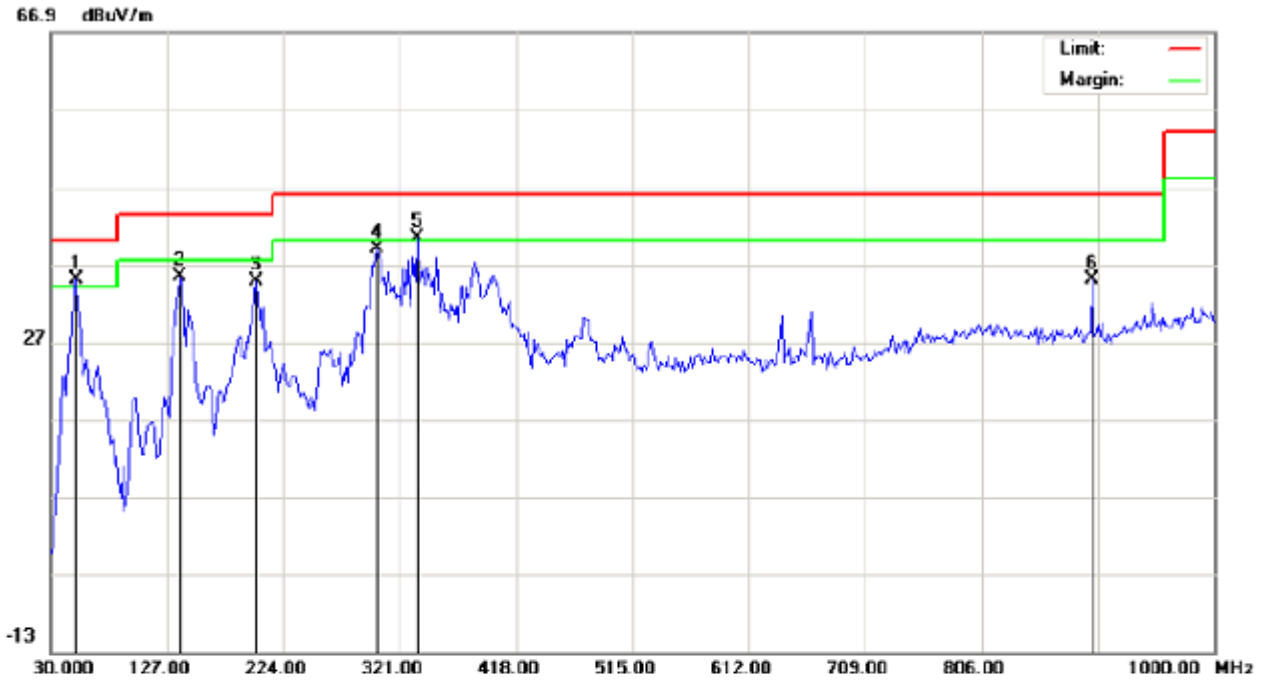

Site: site #1
Limit: FCC Class B 3M Radiation
EUT: Wireless 2-in-1 Adapter
M/N: TT-BA07
Mode: Low Channel TX
Note:

Polarization: *Horizontal*
Power:
Distance:

Temperature: 22.8
Humidity: 54.2 %

No.	Mk	Freq.	Reading	Factor	Measurement	Limit	Over	Detector	Antenna	Table	Comment
		MHz	dBuV	dB/m	dBuV/m	dBuV/m	dB		Height	Degree	
									cm	degree	
1	*	51.0167	24.85	10.15	35.00	40.00	-5.00	peak			
2		138.3163	21.08	14.41	35.49	43.50	-8.01	peak			
3		201.3667	22.92	11.86	34.78	43.50	-8.72	peak			
4		301.6000	23.42	15.52	38.94	46.00	-7.06	peak			
5	!	335.5500	22.58	17.78	40.36	46.00	-5.64	peak			
6		898.1499	6.39	28.56	34.95	46.00	-11.05	peak			

RESULT: PASS

RADIATED EMISSION TEST- (30MHZ-1GHZ)-LOW CHANNEL -VERTICAL

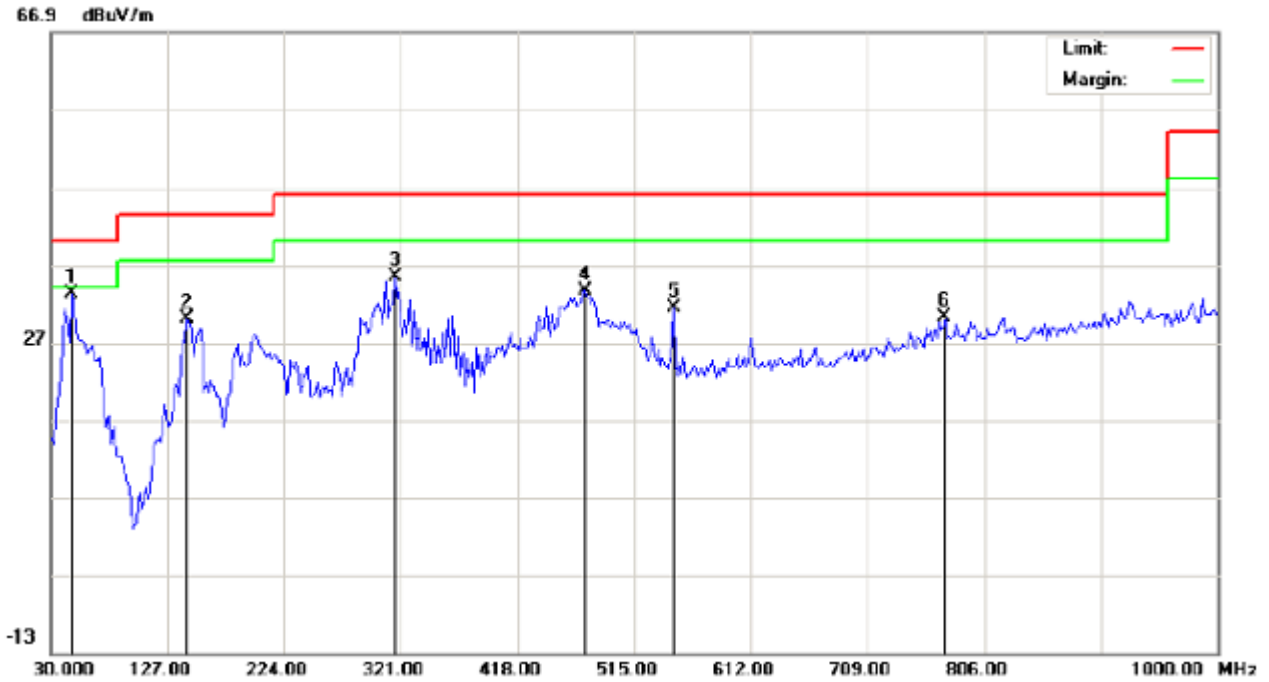

Site: site #1
Limit: FCC Class B 3M Radiation
EUT: Wireless 2-in-1 Adapter
M/N: TT-BA07
Mode: Low Channel TX
Note:

Polarization: *Vertical*
Power:
Distance:

Temperature: 22.8
Humidity: 54.2 %

No.	Mk	Freq.	Reading	Factor	Measurement	Limit	Over	Detector	Antenna Height	Table Degree	Comment
		MHz	dBuV	dB/m	dBuV/m	dBuV/m	dB		cm	degree	
1	*	47.7832	24.83	8.39	33.22	40.00	-6.78	peak			
2		143.1665	14.84	15.22	30.06	43.50	-13.44	peak			
3		316.1499	18.94	16.49	35.43	46.00	-10.57	peak			
4		474.5833	12.77	20.86	33.63	46.00	-12.37	peak			
5		547.3333	9.02	22.41	31.43	46.00	-14.57	peak			
6		773.6666	3.22	26.96	30.18	46.00	-15.82	peak			

RESULT: PASS

Note: 1. Factor=Antenna Factor + Cable loss, Margin=Measurement-Limit.

2. The "Factor" value can be calculated automatically by software of measurement system.

RADIATED EMISSION TEST- (30MHZ-1GHZ)-MIDDLE CHANNEL-HORIZONTAL



Site: site #1
Limit: FCC Class B 3M Radiation
EUT: Wireless 2-in-1 Adapter
M/N: TT-BA07
Mode: Middle Channel TX
Note:

Polarization: *Horizontal*
Power:
Distance:

Temperature: 22.8
Humidity: 54.2 %

No.	Mk	Freq.	Reading	Factor	Measurement	Limit	Over	Detector	Antenna Height	Table Degree	Comment
		MHz	dBuV	dB/m	dBuV/m	dBuV/m	dB		cm	degree	
1		52.6332	24.58	8.41	32.99	40.00	-7.01	peak			
2		135.0833	18.58	12.90	31.48	43.50	-12.02	peak			
3		201.3667	20.64	11.86	32.50	43.50	-11.00	peak			
4	*	299.9832	24.01	15.41	39.42	46.00	-6.58	peak			
5		392.1333	16.86	19.02	35.88	46.00	-10.12	peak			
6		818.9333	2.57	27.32	29.89	46.00	-16.11	peak			

RESULT: PASS

RADIATED EMISSION TEST- (30MHZ-1GHZ)- MIDDLE CHANNEL -VERTICAL

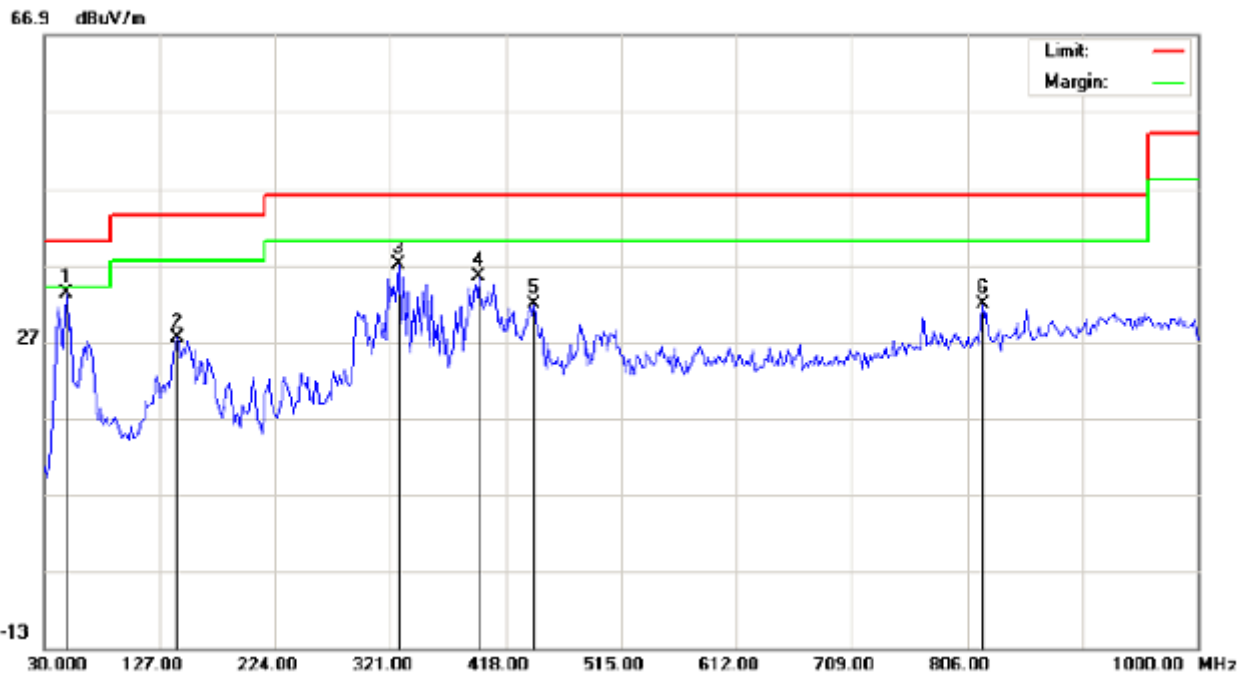

Site: site #1
Limit: FCC Class B 3M Radiation
EUT: Wireless 2-in-1 Adapter
M/N: TT-BA07
Mode: Middle Channel TX
Note:

Polarization: *Vertical*
Power:
Distance:

Temperature: 22.8
Humidity: 54.2 %

No.	Mk	Freq.	Reading	Factor	Measurement	Limit	Over	Detector	Antenna Height	Table Degree	Comment
		MHz	dBuV	dB/m	dBuV/m	dBuV/m	dB		cm	degree	
1	*	49.3999	24.88	8.28	33.16	40.00	-6.84	peak			
2		141.5500	12.23	15.21	27.44	43.50	-16.06	peak			
3		327.4667	19.68	17.24	36.92	46.00	-9.08	peak			
4		395.3666	16.44	19.04	35.48	46.00	-10.52	peak			
5		442.2500	11.40	20.35	31.75	46.00	-14.25	peak			
6		818.9333	4.41	27.32	31.73	46.00	-14.27	peak			

RESULT: PASS

Note: 1. Factor=Antenna Factor + Cable loss, Margin=Measurement-Limit.

2. The "Factor" value can be calculated automatically by software of measurement system.

RADIATED EMISSION TEST- (30MHZ-1GHZ)-HIGH CHANNEL-HORIZONTAL

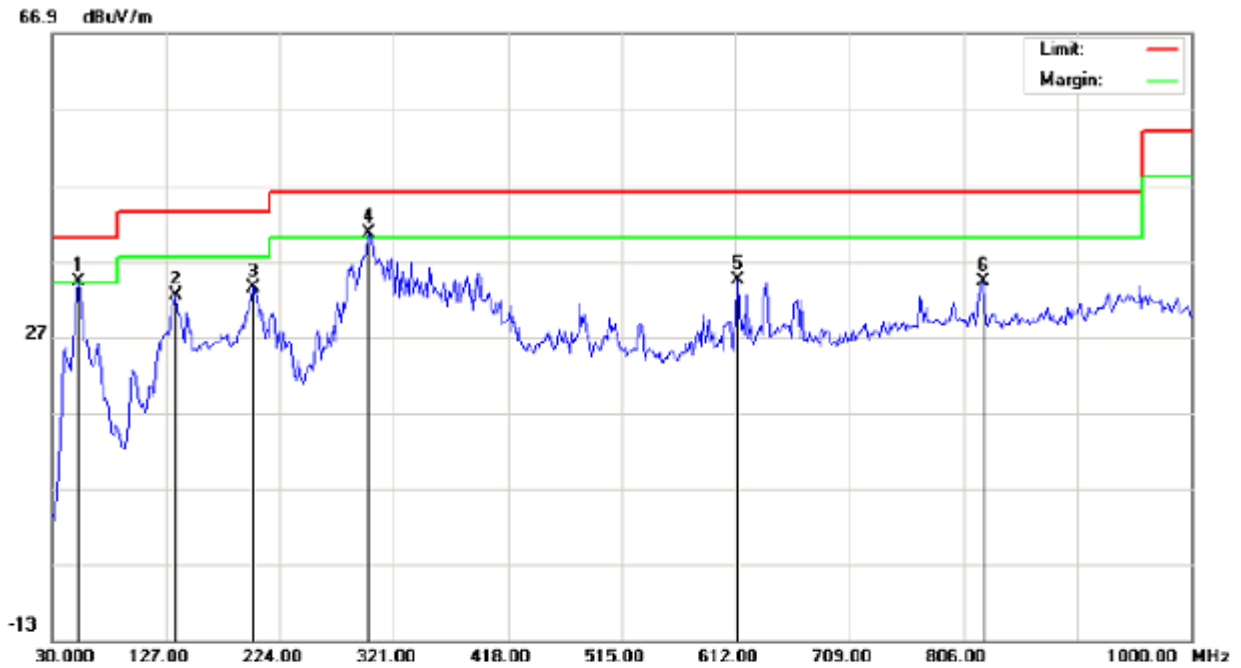

Site: site #1
Limit: FCC Class B 3M Radiation
EUT: Wireless 2-in-1 Adapter
M/N: TT-BA07
Mode: High Channel TX
Note:

Polarization: *Horizontal*
Power:
Distance:

Temperature: 22.8
Humidity: 54.2 %

No.	Mk	Freq.	Reading	Factor	Measurement	Limit	Over	Detector	Antenna Height	Table Degree	Comment
		MHz	dBuV	dB/m	dBuV/m	dBuV/m	dB		cm	degree	
1	!	52.6332	25.71	8.41	34.12	40.00	-5.88	peak			
2		135.0833	19.58	12.90	32.48	43.50	-11.02	peak			
3		201.3667	21.64	11.86	33.50	43.50	-10.00	peak			
4	*	299.9832	25.13	15.41	40.54	46.00	-5.46	peak			
5		613.6167	10.67	23.76	34.43	46.00	-11.57	peak			
6		823.7833	6.91	27.32	34.23	46.00	-11.77	peak			

RESULT: PASS

RADIATED EMISSION TEST- (30MHZ-1GHZ)-HIGH CHANNEL -VERTICAL

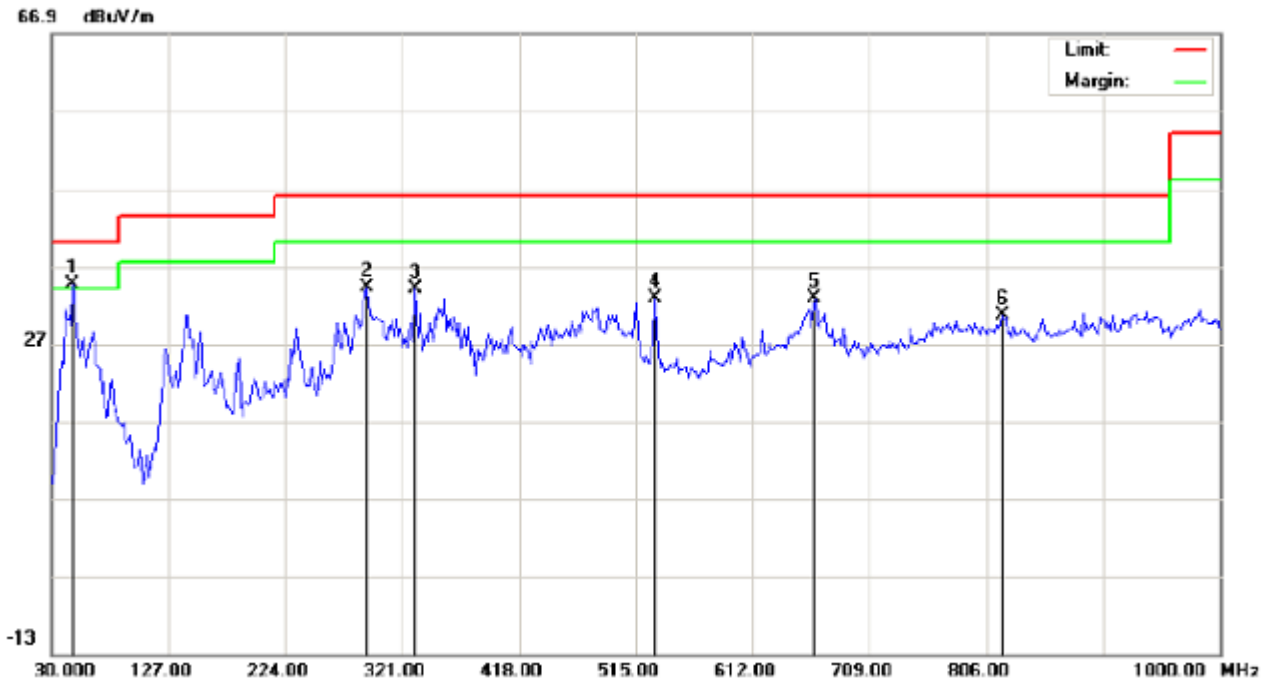

Site: site #1
Limit: FCC Class B 3M Radiation
EUT: Wireless 2-in-1 Adapter
M/N: TT-BA07
Mode: High Channel TX
Note:

Polarization: *Vertical*
Power:
Distance:

Temperature: 22.8
Humidity: 54.2 %

No.	Mk	Freq.	Reading	Factor	Measurement	Limit	Over	Detector	Antenna	Table	Comment
		MHz	dBuV	dB/m	dBuV/m	dBuV/m	dB		Height	Degree	
									cm	degree	
1	*	47.7832	26.20	8.39	34.59	40.00	-5.41	peak			
2		291.8999	18.95	15.17	34.12	46.00	-11.88	peak			
3		332.3167	16.49	17.56	34.05	46.00	-11.95	peak			
4		531.1666	10.92	21.97	32.89	46.00	-13.11	peak			
5		663.7332	8.54	24.22	32.76	46.00	-13.24	peak			
6		818.9333	3.20	27.32	30.52	46.00	-15.48	peak			

RESULT: PASS

Note: 1. Factor=Antenna Factor + Cable loss, Margin=Measurement-Limit.

2. The "Factor" value can be calculated automatically by software of measurement system.

RADIATED EMISSION ABOVE 1GHZ
(Worst modulation: GFSK)
FOR BR/EDR

RADIATED EMISSION TEST- (ABOVE 1GHZ)-LOW CHANNEL-HORIZONTAL

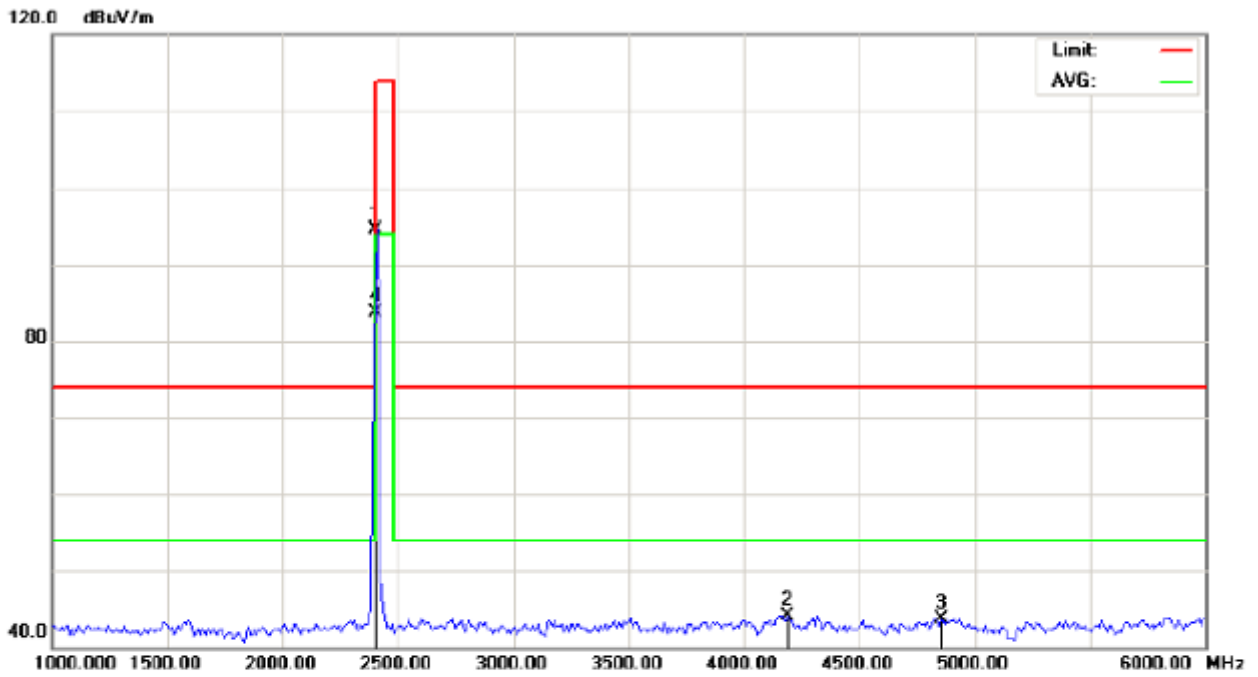

Site: site #1
Limit: FCC Class B 3M Radiation above 1GHZ(PK)-
EUT: Wireless 2-in-1 Adapter
M/N: TT-BA07
Mode: Low Channel TX
Note:

Polarization: *Horizontal*
Power:
Distance: 3m

Temperature: 26
Humidity: 60 %

No.	Mk	Freq.	Reading	Factor	Measurement	Limit	Over	Detector	Antenna Height	Table Degree	Comment
		MHz	dBuV	dB/m	dBuV/m	dBuV/m	dB		cm	degree	
1		2402.000	104.19	-9.68	94.51	114.00	-19.49	peak			
2		4191.667	48.30	-4.16	44.14	74.00	-29.86	peak			
3		4858.333	45.90	-2.17	43.73	74.00	-30.27	peak			
4	*	2402.000	93.36	-9.68	83.68	94.00	-10.32	AVG	100	130	

RESULT: PASS

RADIATED EMISSION TEST- (ABOVE 1GHZ)-LOW CHANNEL- VERTICAL

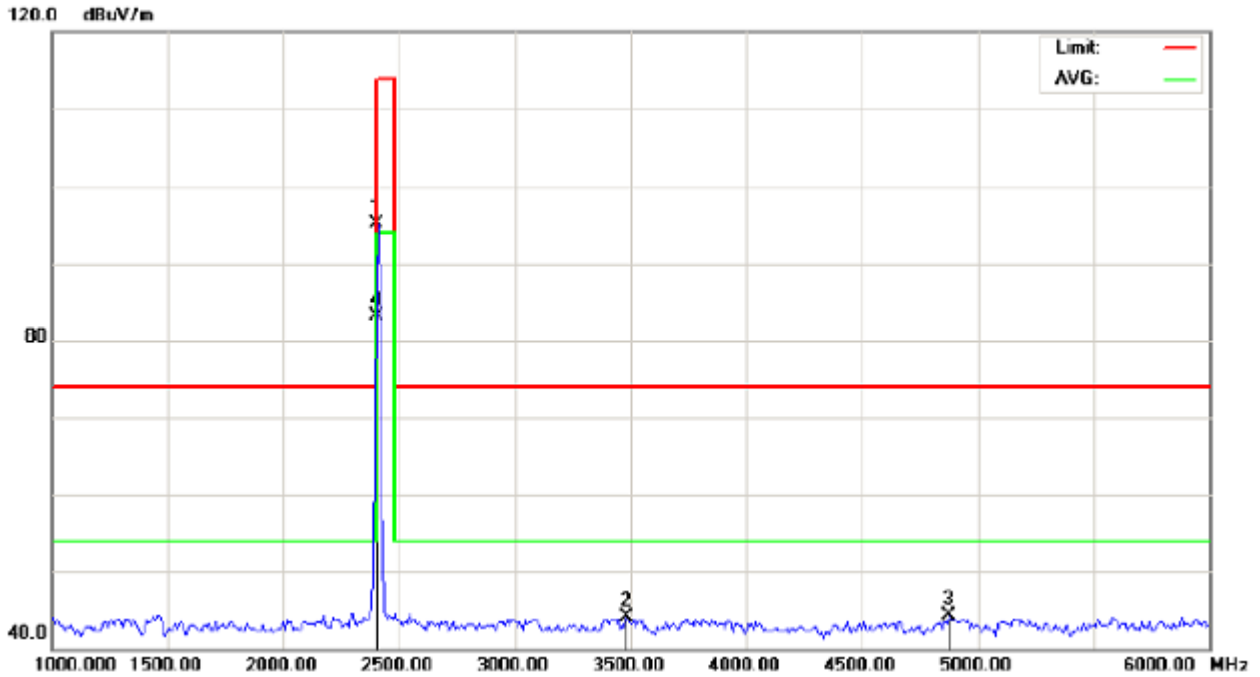

Site: site #1
Limit: FCC Class B 3M Radiation above 1GHZ(PK)-
EUT: Wireless 2-in-1 Adapter
M/N: TT-BA07
Mode: Low Channel TX
Note:

Polarization: *Vertical*
Power:
Distance: 3m

Temperature: 26
Humidity: 60 %

No.	Mk	Freq.	Reading	Factor	Measurement	Limit	Over	Detector	Antenna Height	Table Degree	Comment
		MHz	dBuV	dB/m	dBuV/m	dBuV/m	dB		cm	degree	
1		2402.000	104.76	-9.68	95.08	114.00	-18.92	peak			
2		3483.333	52.03	-7.91	44.12	74.00	-29.88	peak			
3		4875.000	46.51	-2.13	44.38	74.00	-29.62	peak			
4	*	2402.000	92.86	-9.68	83.18	94.00	-10.82	AVG	100	259	

RESULT: PASS

RADIATED EMISSION TEST- (ABOVE 1GHZ)-MIDDLE CHANNEL-HORIZONTAL

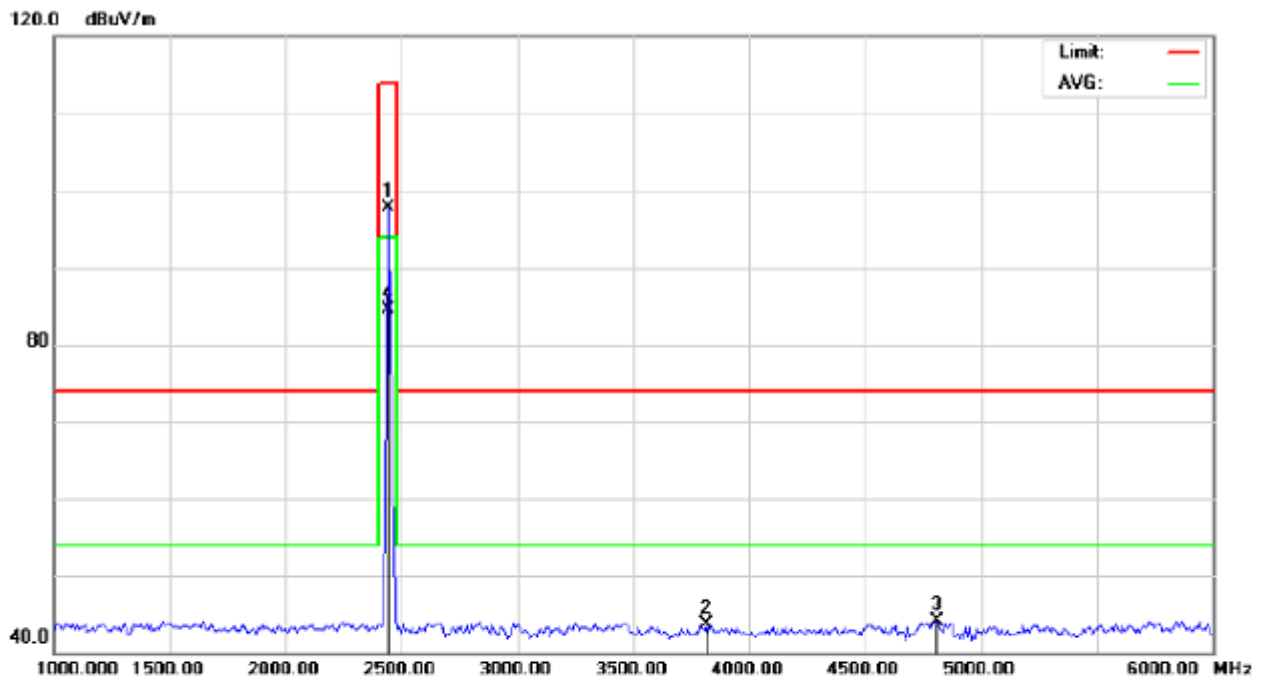

Site: site #1 Polarization: *Horizontal* Temperature: 26
 Limit: FCC Class B 3M Radiation above 1GHZ(PK)- Power: Humidity: 60 %
 EUT: Wireless 2-in-1 Adapter Distance: 3m
 M/N: TT-BA07
 Mode: Middle Channel TX
 Note:

No.	Mk	Freq.	Reading	Factor	Measurement	Limit	Over	Detector	Antenna Height	Table Degree	Comment
		MHz	dBuV	dB/m	dBuV/m	dBuV/m	dB		cm	degree	
1		2441.000	107.31	-9.63	97.68	114.00	-16.32	peak			
2		3816.667	49.57	-5.94	43.63	74.00	-30.37	peak			
3		4808.333	46.36	-2.30	44.06	74.00	-29.94	peak			
4	*	2441.000	94.16	-9.63	84.53	94.00	-9.47	AVG	100	135	

RESULT: PASS

RADIATED EMISSION TEST- (ABOVE 1GHZ)-MIDDLE CHANNEL- VERTICAL

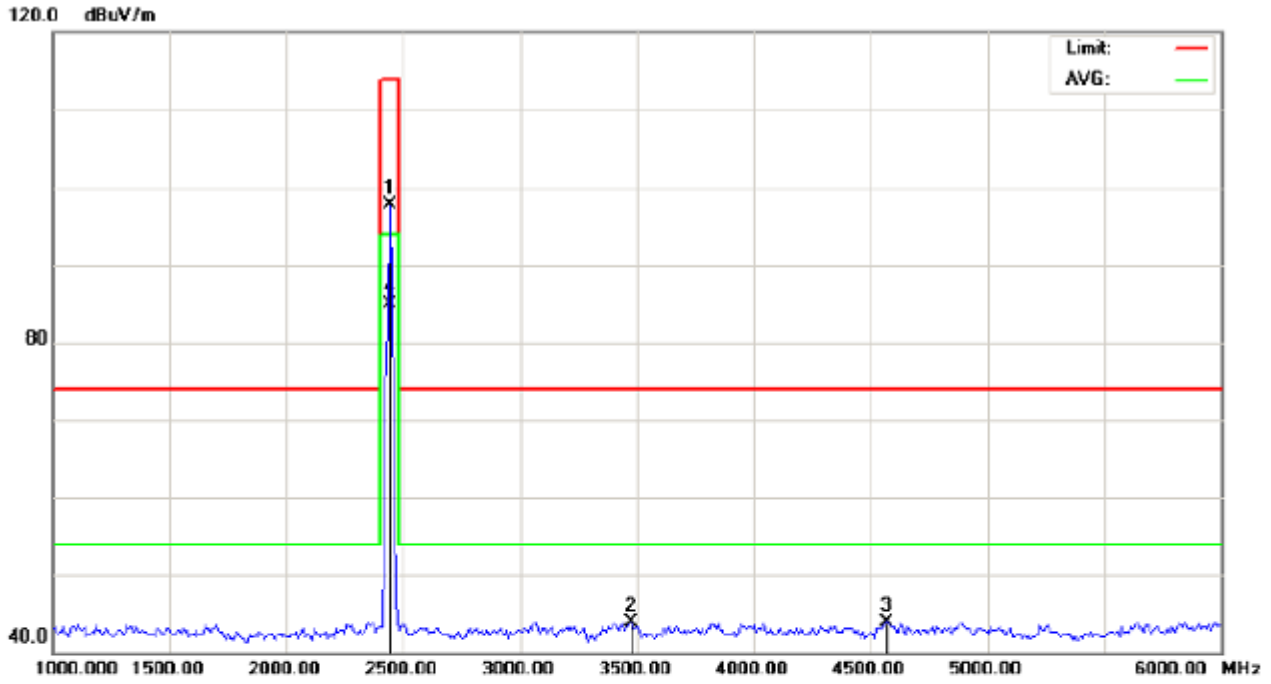

Site: site #1 Polarization: *Vertical* Temperature: 26
 Limit: FCC Class B 3M Radiation above 1GHZ(PK)- Power: Humidity: 60 %
 EUT: Wireless 2-in-1 Adapter Distance: 3m
 M/N: TT-BA07
 Mode: Middle Channel TX
 Note:

No.	Mk	Freq.	Reading	Factor	Measurement	Limit	Over	Detector	Antenna	Table	Comment
		MHz	dBuV	dB/m	dBuV/m	dBuV/m	dB		Height	Degree	
1		2441.000	107.26	-9.63	97.63	114.00	-16.37	peak			
2		3475.000	51.87	-7.91	43.96	74.00	-30.04	peak			
3		4566.667	46.94	-2.94	44.00	74.00	-30.00	peak			
4	*	2441.000	94.52	-9.63	84.89	94.00	-9.11	AVG	100	263	

RESULT: PASS

RADIATED EMISSION TEST- (ABOVE 1GHZ)-HIGH CHANNEL-HORIZONTAL

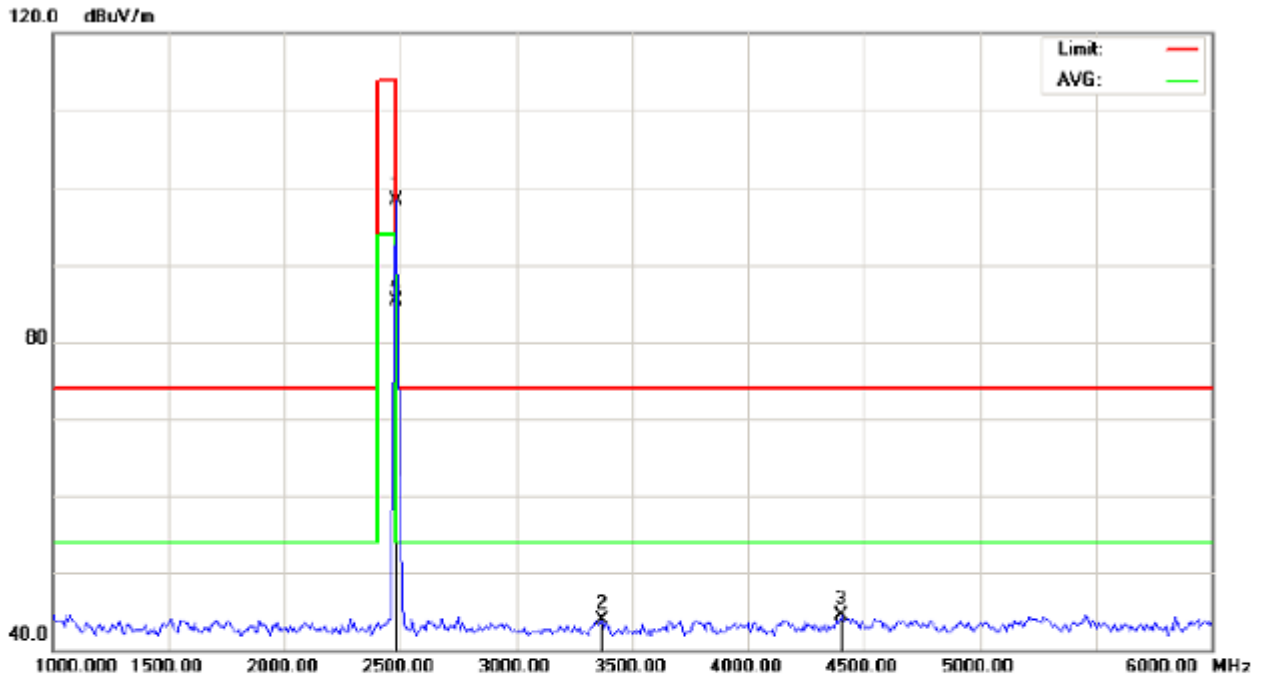

Site: site #1
Limit: FCC Class B 3M Radiation above 1GHZ(PK)-
EUT: Wireless 2-in-1 Adapter
M/N: TT-BA07
Mode: High Channel TX
Note:

Polarization: *Horizontal*
Power:
Distance: 3m

Temperature: 26
Humidity: 60 %

No.	Mk	Freq.	Reading	Factor	Measurement	Limit	Over	Detector	Antenna Height	Table Degree	Comment
		MHz	dBuV	dB/m	dBuV/m	dBuV/m	dB		cm	degree	
1		2480.000	107.85	-9.59	98.26	114.00	-15.74	peak			
2		3366.667	51.92	-8.02	43.90	74.00	-30.10	peak			
3		4400.000	48.02	-3.45	44.57	74.00	-29.43	peak			
4	*	2480.000	94.97	-9.59	85.38	94.00	-8.62	AVG	100	128	

RESULT: PASS

RADIATED EMISSION TEST- (ABOVE 1GHZ)-HIGH CHANNEL- VERTICAL

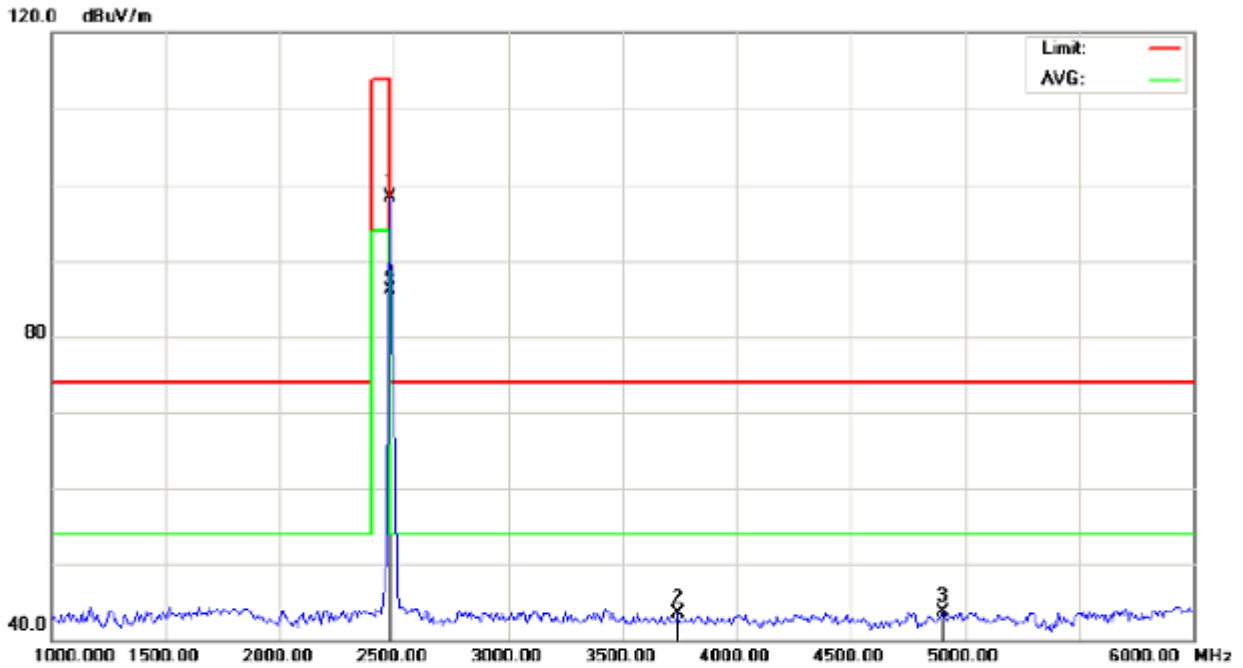

Site: site #1 Polarization: *Vertical* Temperature: 26
 Limit: FCC Class B 3M Radiation above 1GHZ(PK)- Power: Humidity: 60 %
 EUT: Wireless 2-in-1 Adapter Distance: 3m
 M/N: TT-BA07
 Mode: High Channel TX
 Note:

No.	Mk	Freq.	Reading	Factor	Measurement	Limit	Over	Detector	Antenna Height	Table Degree	Comment
		MHz	dBuV	dB/m	dBuV/m	dBuV/m	dB		cm	degree	
1		2480.000	107.88	-9.59	98.29	114.00	-15.71	peak			
2		3741.667	49.98	-6.40	43.58	74.00	-30.42	peak			
3		4900.000	45.68	-2.06	43.62	74.00	-30.38	peak			
4	*	2480.000	95.61	-9.59	86.02	94.00	-7.98	AVG	100	256	

RESULT: PASS

Note: 6~25GHz at least have 20dB margin. No recording in the test report.

Factor=Antenna Factor + Cable loss - Amplifier gain, Margin=Measurement-Limit.

The "Factor" value can be calculated automatically by software of measurement system.

Field strength of the fundamental signal

Peak value

Frequency	Reading Level	Factor	Measurement	Limit	Over	Antenna
(MHz)	(dBuv)	(dB/m)	(dBuv/m)	(dBuv/m)	(dB)	Polarization
2402	104.19	-9.68	94.51	114	-19.49	Horizontal
2402	104.76	-9.68	95.08	114	-18.92	Vertical
2441	107.31	-9.63	97.68	114	-16.32	Horizontal
2441	107.26	-9.63	97.63	114	-16.37	Vertical
2480	107.85	-9.59	98.26	114	-15.74	Horizontal
2480	107.88	-9.59	98.29	114	-15.71	Vertical

Average value

Frequency	Reading Level	Factor	Measurement	Limit	Over	Antenna
(MHz)	(dBuv)	(dB/m)	(dBuv/m)	(dBuv/m)	(dB)	Polarization
2402	93.36	-9.68	83.68	94	-10.32	Horizontal
2402	92.86	-9.68	83.18	94	-10.82	Vertical
2441	94.16	-9.63	84.53	94	-9.47	Horizontal
2441	94.52	-9.63	84.89	94	-9.11	Vertical
2480	94.97	-9.59	85.38	94	-8.62	Horizontal
2480	95.61	-9.59	86.02	94	-7.98	Vertical

FOR BLE

RADIATED EMISSION TEST- (ABOVE 1GHZ)-LOW CHANNEL-HORIZONTAL

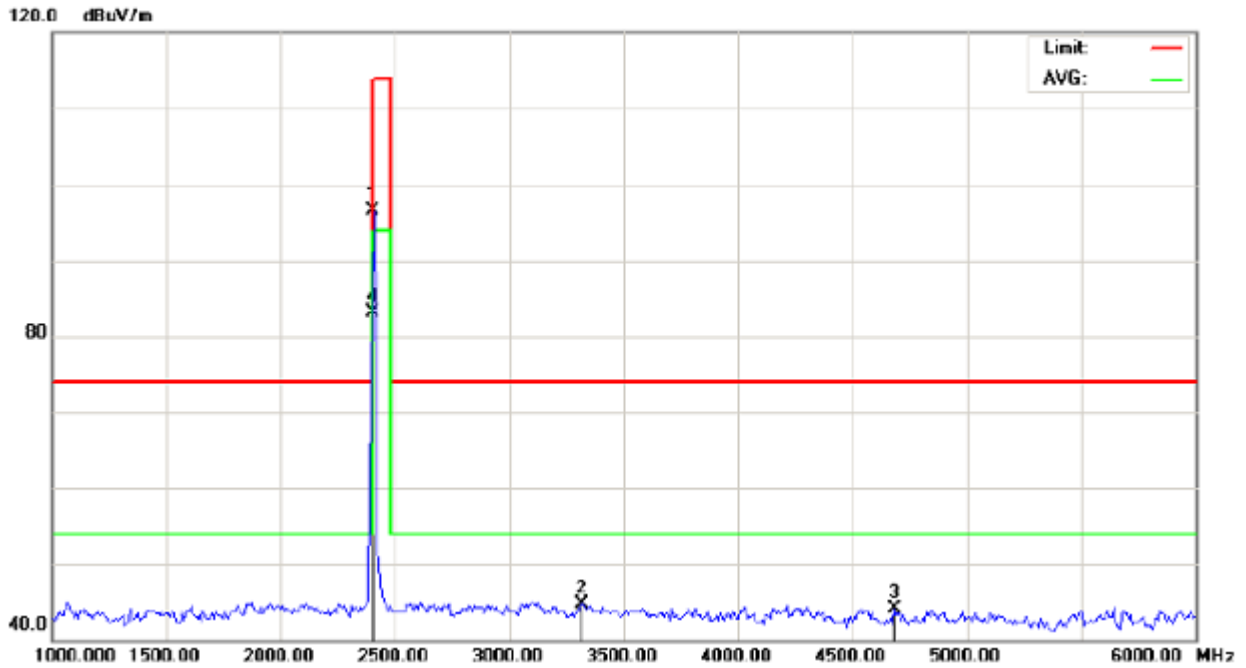

Site: site #1	Polarization: <i>Horizontal</i>	Temperature: 26
Limit: FCC Class B 3M Radiation above 1GHZ(PK)-	Power:	Humidity: 60 %
EUT: Wireless 2-in-1 Adapter	Distance: 3m	
M/N: TT-BA07		
Mode: Low Channel TX		
Note:		

No.	Mk	Freq.	Reading	Factor	Measurement	Limit	Over	Detector	Antenna	Table	Comment
		MHz	dBuV	dB/m	dBuV/m	dBuV/m	dB		Height	Degree	
									cm	degree	
1		2402.000	106.25	-9.68	96.57	114.00	-17.43	peak			
2		3316.667	52.83	-8.06	44.77	74.00	-29.23	peak			
3		4683.333	46.73	-2.63	44.10	74.00	-29.90	peak			
4	*	2402.000	92.85	-9.68	83.17	94.00	-10.83	AVG	100	176	

RESULT: PASS

RADIATED EMISSION TEST- (ABOVE 1GHZ)-LOW CHANNEL- VERTICAL

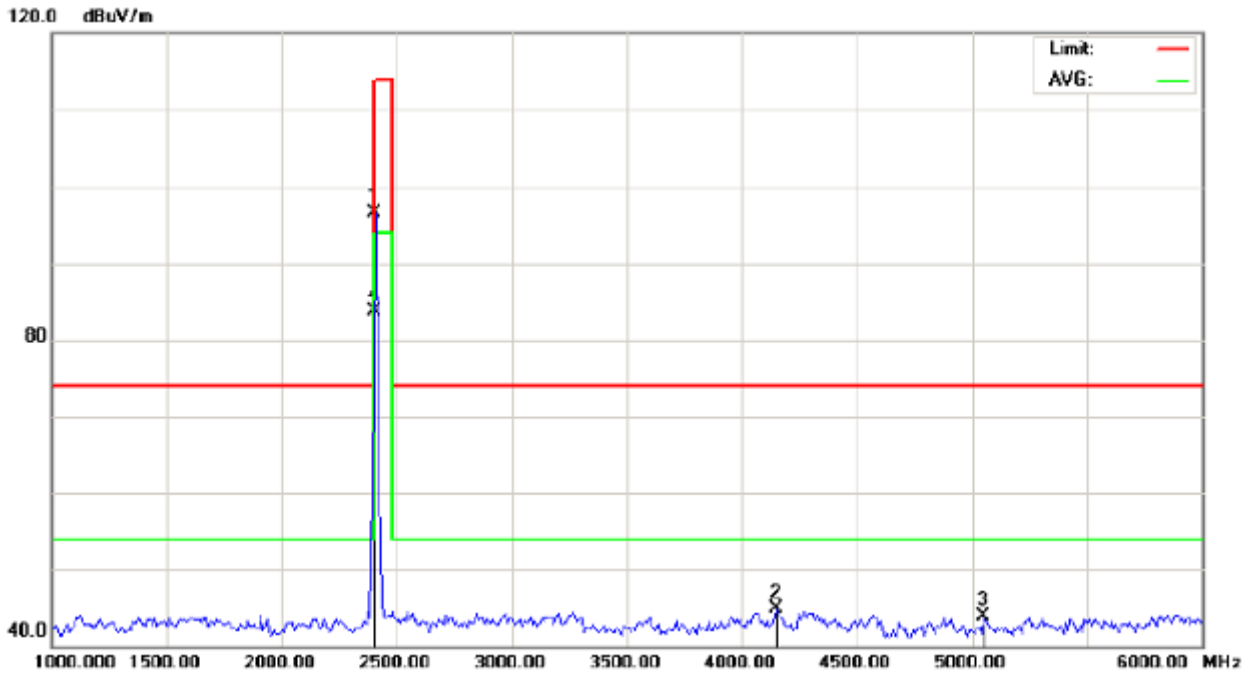

Site: site #1
Limit: FCC Class B 3M Radiation above 1GHZ(PK)-
EUT: Wireless 2-in-1 Adapter
M/N: TT-BA07
Mode: Low Channel TX
Note:

Polarization: *Vertical*
Power:
Distance: 3m

Temperature: 26
Humidity: 60 %

No.	Mk	Freq.	Reading	Factor	Measurement	Limit	Over	Detector	Antenna Height	Table Degree	Comment
		MHz	dBuV	dB/m	dBuV/m	dBuV/m	dB		cm	degree	
1		2402.000	106.21	-9.68	96.53	114.00	-17.47	peak			
2		4150.000	49.27	-4.30	44.97	74.00	-29.03	peak			
3		5050.000	45.75	-1.80	43.95	74.00	-30.05	peak			
4	*	2402.000	93.34	-9.68	83.66	94.00	-10.34	AVG	100	279	

RESULT: PASS

RADIATED EMISSION TEST- (ABOVE 1GHZ)-MIDDLE CHANNEL-HORIZONTAL

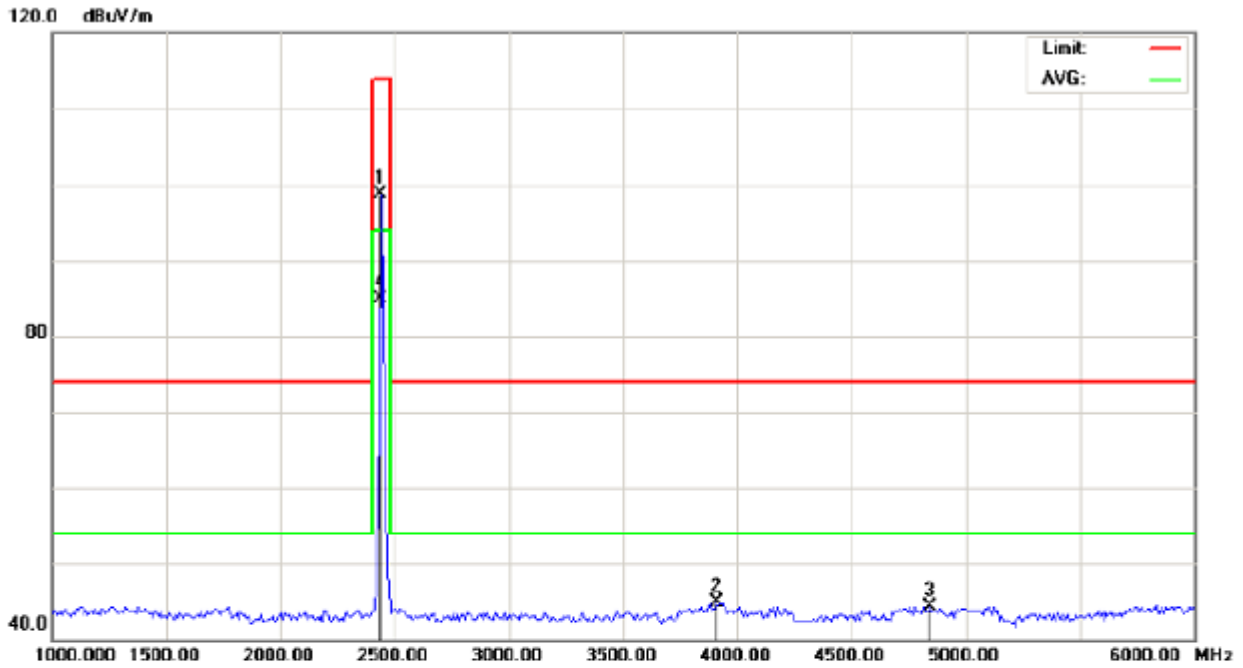

Site: site #1
 Limit: FCC Class B 3M Radiation above 1GHZ(PK)-
 EUT: Wireless 2-in-1 Adapter
 M/N: TT-BA07
 Mode: Middle Channel TX
 Note:

Polarization: *Horizontal*
 Power:
 Distance: 3m

Temperature: 26
 Humidity: 60 %

No.	Mk	Freq.	Reading	Factor	Measurement	Limit	Over	Detector	Antenna Height	Table Degree	Comment
		MHz	dBuV	dB/m	dBuV/m	dBuV/m	dB		cm	degree	
1		2440.000	108.33	-9.64	98.69	114.00	-15.31	peak			
2		3908.333	50.22	-5.37	44.85	74.00	-29.15	peak			
3		4841.667	46.51	-2.21	44.30	74.00	-29.70	peak			
4	*	2440.000	94.52	-9.64	84.88	94.00	-9.12	AVG	100	174	

RESULT: PASS

RADIATED EMISSION TEST- (ABOVE 1GHZ)-MIDDLE CHANNEL- VERTICAL

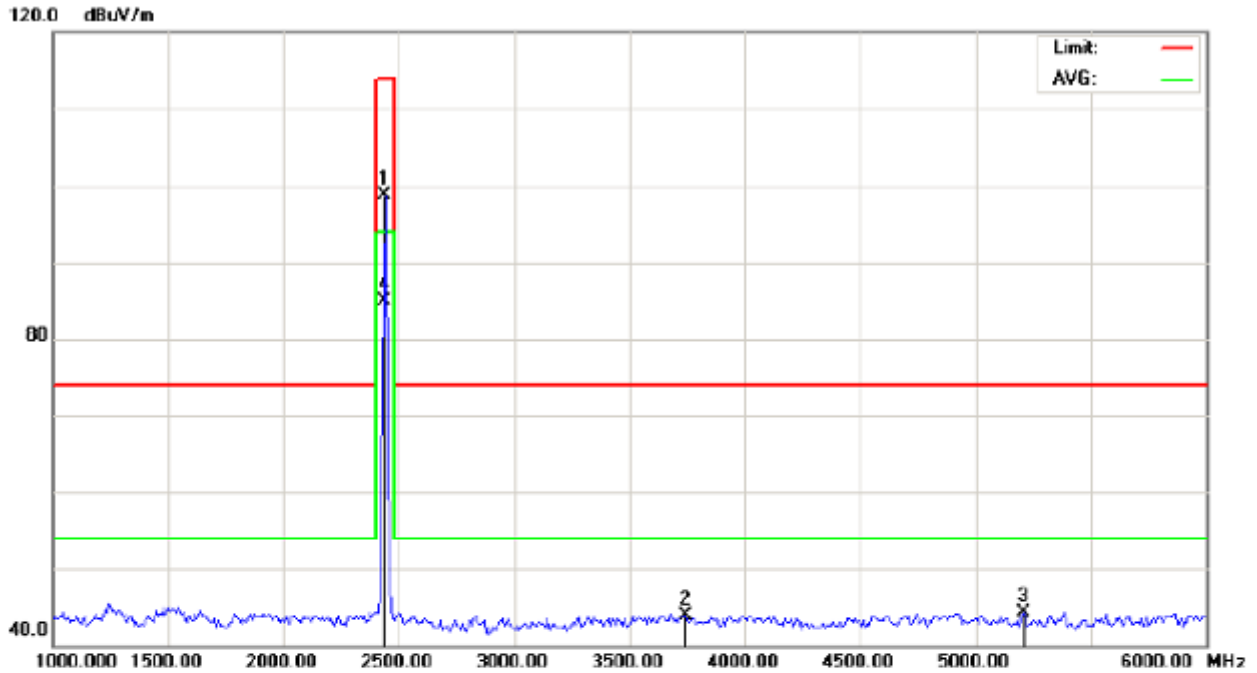

Site: site #1 Polarization: *Vertical* Temperature: 26
Limit: FCC Class B 3M Radiation above 1GHZ(PK)- Power: Humidity: 60 %
EUT: Wireless 2-in-1 Adapter- Distance: 3m
M/N: TT-BA07
Mode: Middle Channel TX
Note:

No.	Mk	Freq.	Reading	Factor	Measurement	Limit	Over	Detector	Antenna Height	Table Degree	Comment
		MHz	dBuV	dB/m	dBuV/m	dBuV/m	dB		cm	degree	
1		2440.000	108.27	-9.64	98.63	114.00	-15.37	peak			
2		3741.667	50.27	-6.40	43.87	74.00	-30.13	peak			
3		5208.333	46.05	-1.80	44.25	74.00	-29.75	peak			
4	*	2440.000	94.62	-9.64	84.98	94.00	-9.02	AVG	100	277	

RESULT: PASS

RADIATED EMISSION TEST- (ABOVE 1GHZ)-HIGH CHANNEL-HORIZONTAL

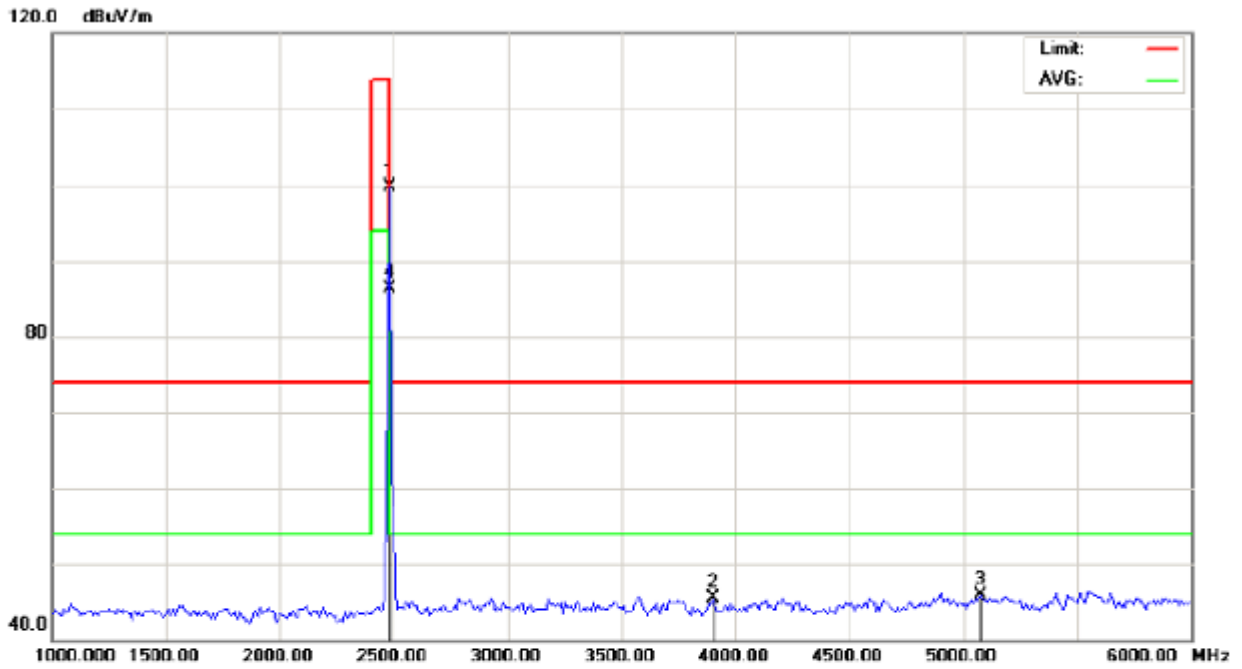

Site: site #1
Limit: FCC Class B 3M Radiation above 1GHZ(PK)-
EUT: Wireless 2-in-1 Adapter
M/N: TT-BA07
Mode: High Channel TX
Note:

Polarization: *Horizontal*
Power:
Distance: 3m

Temperature: 26
Humidity: 60 %

No.	Mk	Freq.	Reading	Factor	Measurement	Limit	Over	Detector	Antenna	Table	Comment
		MHz	dBuV	dB/m	dBuV/m	dBuV/m	dB		Height	Degree	
									cm	degree	
1		2480.000	109.36	-9.59	99.77	114.00	-14.23	peak			
2		3900.000	50.95	-5.43	45.52	74.00	-28.48	peak			
3		5075.000	47.62	-1.80	45.82	74.00	-28.18	peak			
4	*	2480.000	95.86	-9.59	86.27	94.00	-7.73	AVG	100	181	

RESULT: PASS

RADIATED EMISSION TEST- (ABOVE 1GHZ)-HIGH CHANNEL- VERTICAL

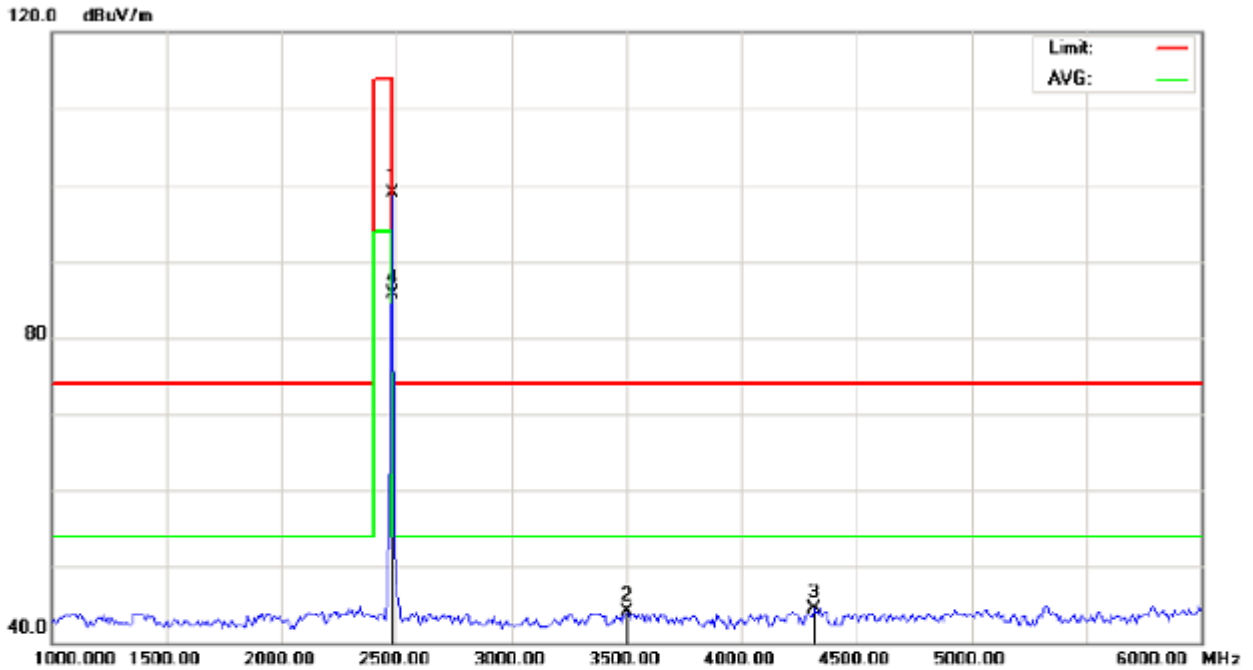

Site: site #1 Polarization: *Vertical* Temperature: 26
 Limit: FCC Class B 3M Radiation above 1GHZ(PK)- Power: Humidity: 60 %
 EUT: Wireless 2-in-1 Adapter Distance: 3m
 M/N: TT-BA07
 Mode: High Channel TX
 Note:

No.	Mk	Freq.	Reading	Factor	Measurement	Limit	Over	Detector	Antenna	Table	Comment
		MHz	dBuV	dB/m	dBuV/m	dBuV/m	dB		Height	Degree	
									cm	degree	
1		2480.000	108.40	-9.59	98.81	114.00	-15.19	peak			
2		3500.000	51.97	-7.89	44.08	74.00	-29.92	peak			
3		4316.667	48.27	-3.73	44.54	74.00	-29.46	peak			
4	*	2480.000	95.32	-9.59	85.73	94.00	-8.27	AVG	100	283	

RESULT: PASS

Note: 6~25GHz at least have 20dB margin. No recording in the test report.

Factor=Antenna Factor + Cable loss - Amplifier gain, Margin=Measurement-Limit.

The "Factor" value can be calculated automatically by software of measurement system.

Field strength of the fundamental signal

Peak value

Frequency	Reading Level	Factor	Measurement	Limit	Over	Antenna
(MHz)	(dBuv)	(dB/m)	(dBuv/m)	(dBuv/m)	(dB)	Polarization
2402	106.25	-9.68	96.57	114	-17.43	Horizontal
2402	106.21	-9.68	96.53	114	-17.47	Vertical
2440	108.33	-9.64	98.69	114	-15.31	Horizontal
2440	108.27	-9.64	98.63	114	-15.37	Vertical
2480	109.36	-9.59	99.77	114	-14.23	Horizontal
2480	108.40	-9.59	98.81	114	-15.19	Vertical

Average value

Frequency	Reading Level	Factor	Measurement	Limit	Over	Antenna
(MHz)	(dBuv)	(dB/m)	(dBuv/m)	(dBuv/m)	(dB)	Polarization
2402	92.85	-9.68	83.17	94	-10.83	Horizontal
2402	93.34	-9.68	83.66	94	-10.34	Vertical
2440	94.52	-9.64	84.88	94	-9.12	Horizontal
2440	94.62	-9.64	84.98	94	-9.02	Vertical
2480	95.86	-9.59	86.27	94	-7.73	Horizontal
2480	95.32	-9.59	85.73	94	-8.27	Vertical

10. BAND EDGE EMISSION

10.1. MEASUREMENT PROCEDURE

1The EUT operates at hopping-off test mode. The lowest or highest channels are tested to verify the largest transmission and spurious emissions power at the continuous transmission mode.

2Max hold the trace of the setp 1,and the EUT operates at hopping-on test mode to verify the largest spurious emissions power.

3Set the spectrum analyzer in the following setting in order to capture the lower and upper band-edges of the emission: (a) PEAK: RBW=VBW=1.5MHz / Sweep=AUTO

(b) AVERAGE: RBW=1.5MHz ; VBW=1/on time(1KHz) / Sweep=AUTO

10.2 TEST SETUP

RADIATED EMISSION TEST SETUP

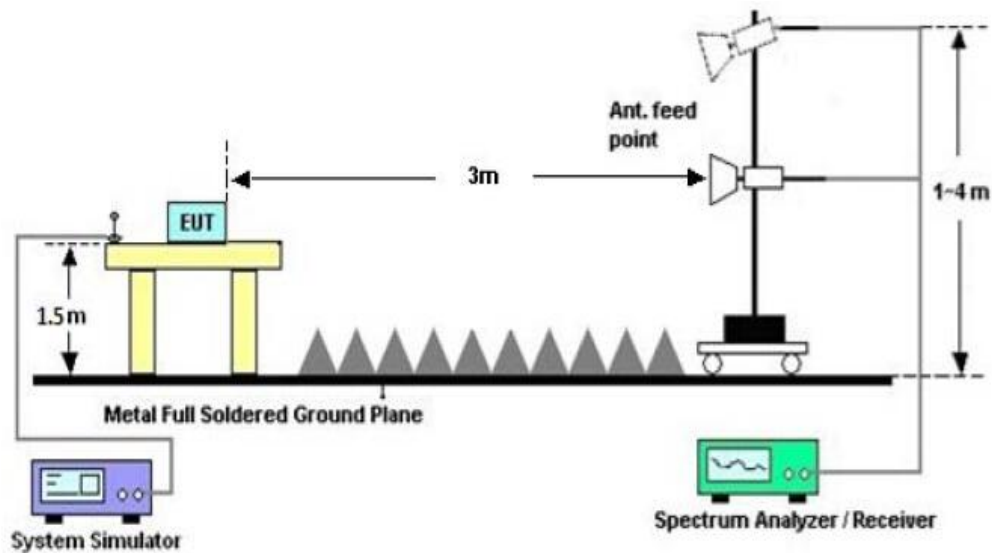

10.3 RADIATED TEST RESULT

(Worst modulation: GFSK)

FOR BR/EDR

TEST PLOT OF BAND EDGE FOR LOW CHANNEL-Horizontal

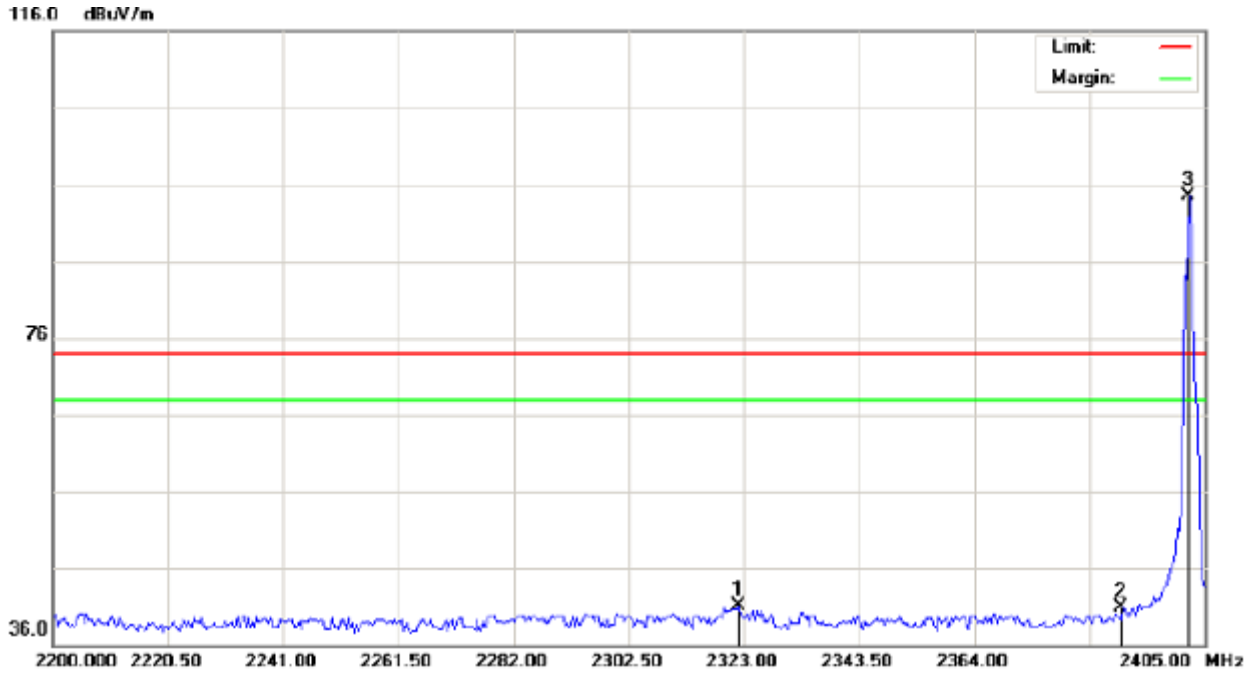

Site: site #1 Polarization: *Horizontal* Temperature: 26
Limit: FCC Class B 3M Radiation above 1GHZ(PK) Power: Humidity: 60 %
EUT: Wireless 2-in-1 Adapter Distance:
M/N: TT-BA07
Mode: Low Channel TX
Note:

No.	Mk	Freq.	Reading	Factor	Measurement	Limit	Over	Detector	Antenna Height	Table Degree	Comment
		MHz	dBuV	dB/m	dBuV/m	dBuV/m	dB		cm	degree	
1		2321.975	30.84	10.23	41.07	74.00	-32.93	peak			
2		2390.000	30.50	10.31	40.81	74.00	-33.19	peak			
3	*	2402.000	84.22	10.32	94.54	74.00	20.54	peak			

TEST PLOT OF BAND EDGE FOR LOW CHANNEL –Vertical

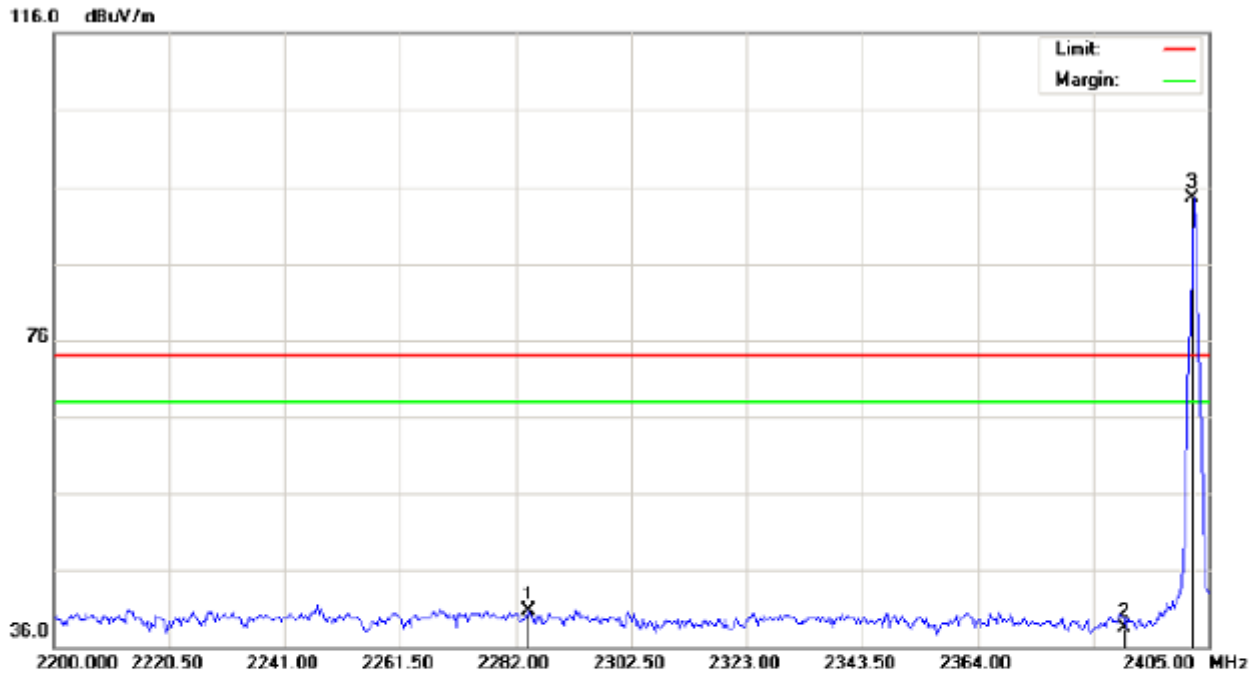

Site: site #1

Limit: FCC Class B 3M Radiation above 1GHZ(PK)

EUT: Wireless 2-in-1 Adapter

M/N: TT-BA07

Mode: Low Channel TX

Note:

Polarization: *Vertical*

Power:

Distance:

Temperature: 26

Humidity: 60 %

No.	Mk	Freq.	Reading	Factor	Measurement	Limit	Over	Detector	Antenna Height	Table Degree	Comment
		MHz	dBuV	dB/m	dBuV/m	dBuV/m	dB		cm	degree	
1		2284.392	30.60	10.19	40.79	74.00	-33.21	peak			
2		2390.000	28.21	10.31	38.52	74.00	-35.48	peak			
3	*	2402.000	84.09	10.32	94.41	74.00	20.41	peak			

TEST PLOT OF BAND EDGE FOR HIGH CHANNEL -Horizontal

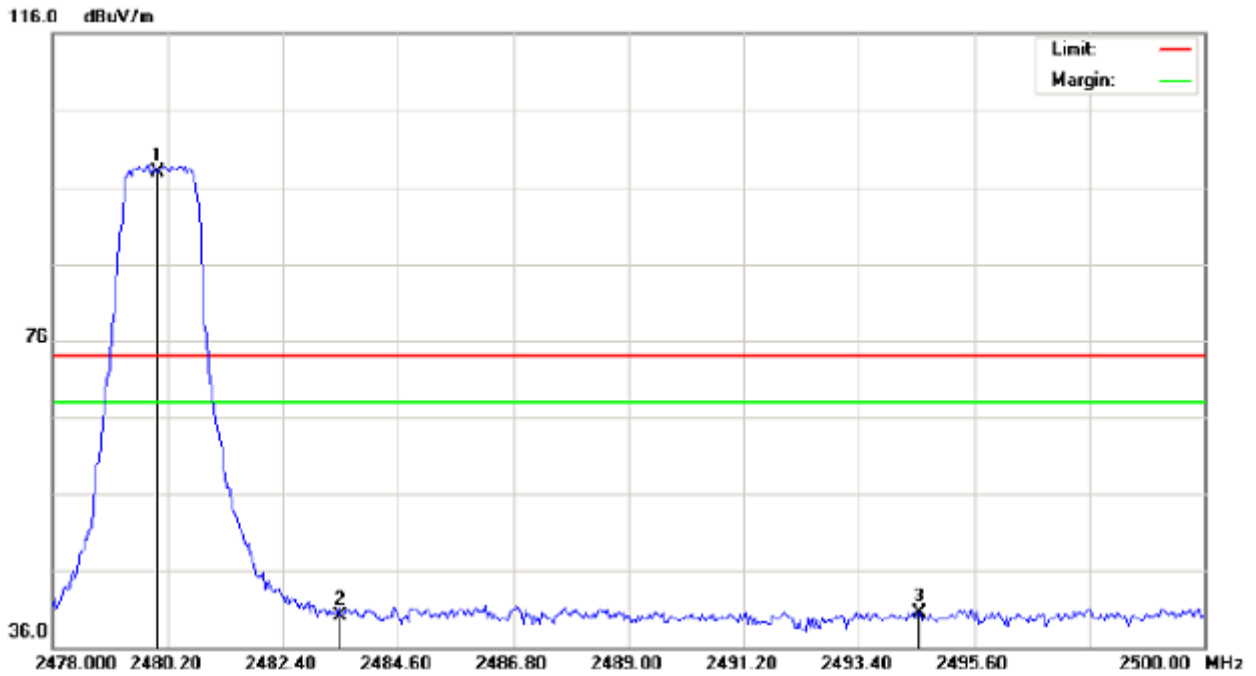

Site: site #1 Polarization: *Horizontal* Temperature: 26
 Limit: FCC Class B 3M Radiation above 1GHZ(PK) Power: Humidity: 60 %
 EUT: Wireless 2-in-1 Adapter Distance:
 M/N: TT-BA07
 Mode: High Channel TX
 Note:

No.	Mk	Freq.	Reading	Factor	Measurement	Limit	Over	Detector	Antenna Height	Table Degree	Comment
		MHz	dBuV	dB/m	dBuV/m	dBuV/m	dB		cm	degree	
1	*	2480.000	87.55	10.41	97.96	74.00	23.96	peak			
2		2483.500	29.69	10.41	40.10	74.00	-33.90	peak			
3		2494.573	30.03	10.42	40.45	74.00	-33.55	peak			

TEST PLOT OF BAND EDGE FOR HIGH CHANNEL-Vertical

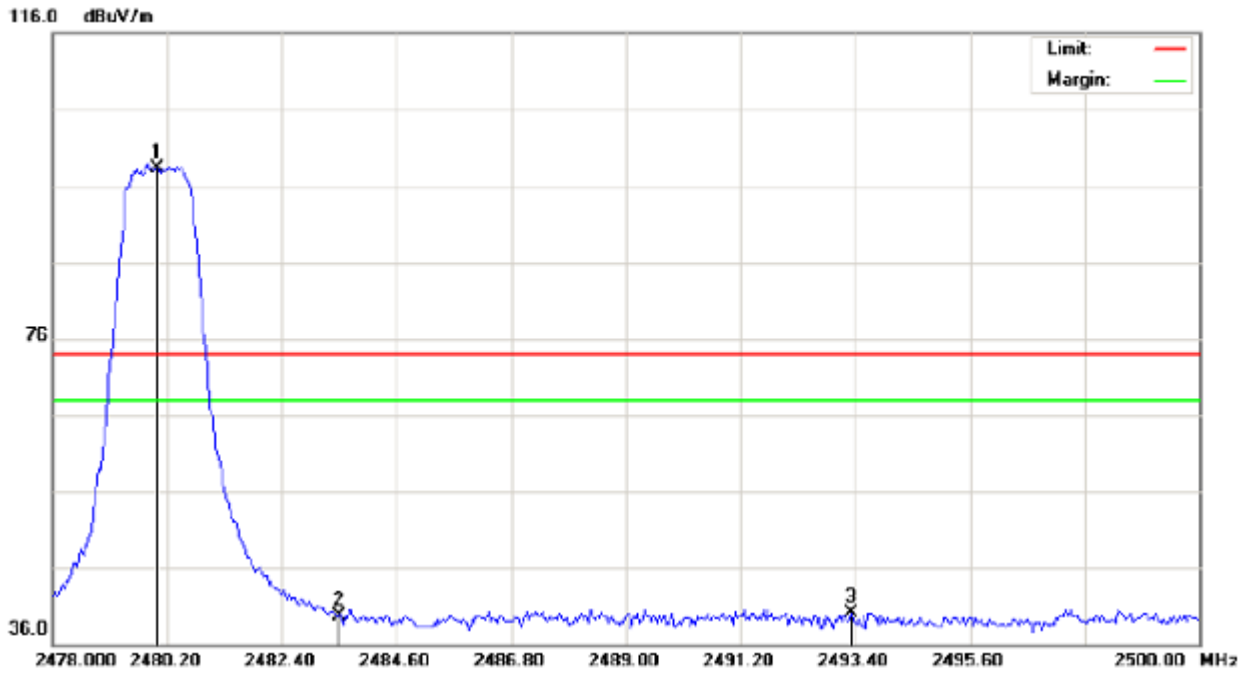

Site: site #1 Polarization: *Vertical* Temperature: 26
 Limit: FCC Class B 3M Radiation above 1GHZ(PK) Power: Humidity: 60 %
 EUT: Wireless 2-in-1 Adapter Distance:
 M/N: TT-BA07
 Mode: High Channel TX
 Note:

No.	Mk	Freq.	Reading	Factor	Measurement	Limit	Over	Detector	Antenna Height	Table Degree	Comment
		MHz	dBuV	dB/m	dBuV/m	dBuV/m	dB		cm	degree	
1	*	2480.000	87.82	10.41	98.23	74.00	24.23	peak			
2		2483.500	29.26	10.41	39.67	74.00	-34.33	peak			
3		2493.327	29.66	10.42	40.08	74.00	-33.92	peak			

RESULT: PASS

Note: The other modes radiation emission have enough 20dB margin.

Factor=Antenna Factor + Cable loss - Amplifier gain, Over=Measure-Limit.

The “Factor” value can be calculated automatically by software of measurement system.

FOR BLE

TEST PLOT OF BAND EDGE FOR LOW CHANNEL-Horizontal

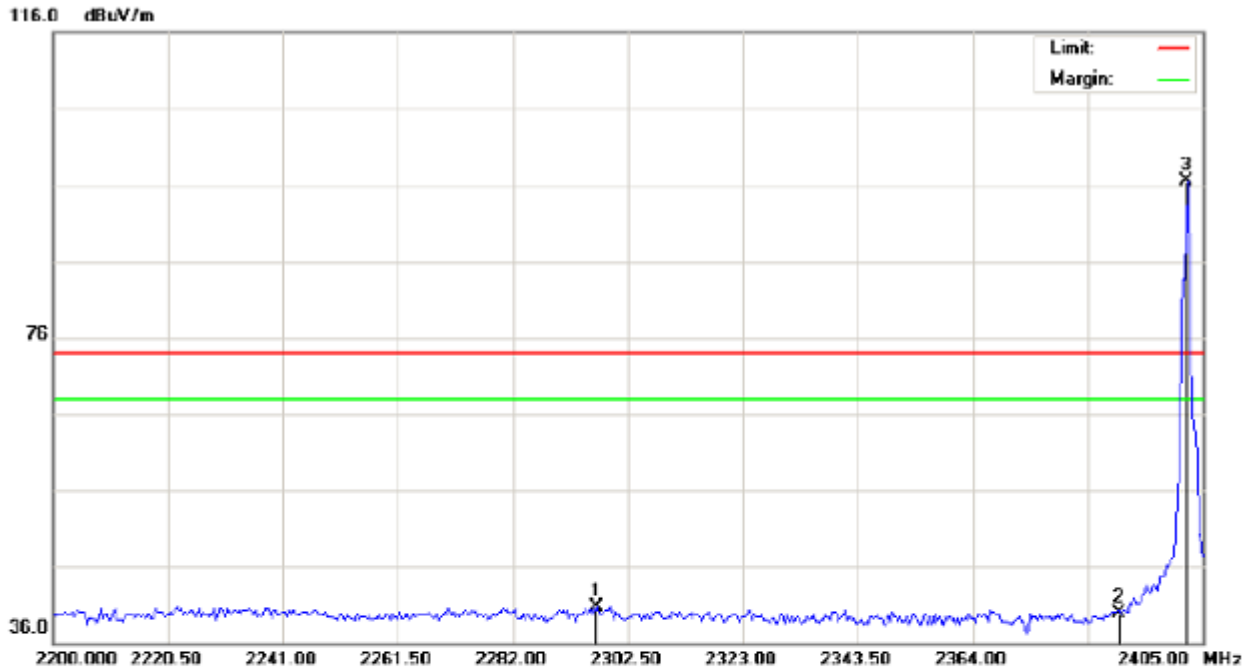

Site: site #1
Limit: FCC Class B 3M Radiation above 1GHZ(PK)
EUT: Wireless 2-in-1 Adapter
M/N: TT-BA07
Mode: Low Channel TX
Note:

Polarization: *Horizontal*
Power:
Distance:

Temperature: 26
Humidity: 60 %

No.	Mk	Freq.	Reading	Factor	Measurement	Limit	Over	Detector	Antenna Height	Table Degree	Comment
		MHz	dBuV	dB/m	dBuV/m	dBuV/m	dB		cm	degree	
1		2297.033	30.46	10.21	40.67	74.00	-33.33	peak			
2		2390.000	29.50	10.31	39.81	74.00	-34.19	peak			
3	*	2402.000	86.22	10.32	96.54	74.00	22.54	peak			

TEST PLOT OF BAND EDGE FOR LOW CHANNEL –Vertical

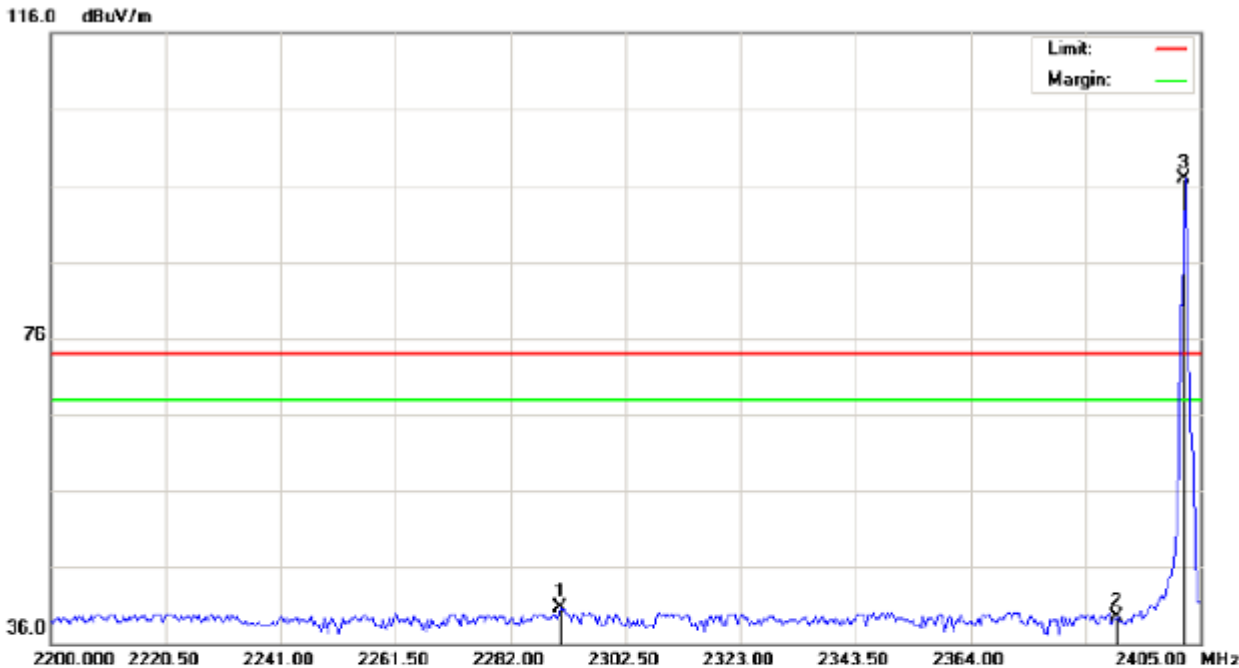

Site: site #1
Limit: FCC Class B 3M Radiation above 1GHZ(PK)
EUT: Wireless 2-in-1 Adapter
M/N: TT-BA07
Mode: Low Channel TX
Note:
Polarization: *Vertical*
Power:
Distance:
Temperature: 26
Humidity: 60 %

No.	Mk	Freq.	Reading	Factor	Measurement	Limit	Over	Detector	Antenna Height	Table Degree	Comment
		MHz	dBuV	dB/m	dBuV/m	dBuV/m	dB		cm	degree	
1	-	2290.883	30.47	10.20	40.67	74.00	-33.33	peak			
2	-	2390.000	29.21	10.31	39.52	74.00	-34.48	peak			
3	*	2402.000	86.59	10.32	96.91	74.00	22.91	peak			

TEST PLOT OF BAND EDGE FOR HIGH CHANNEL -Horizontal

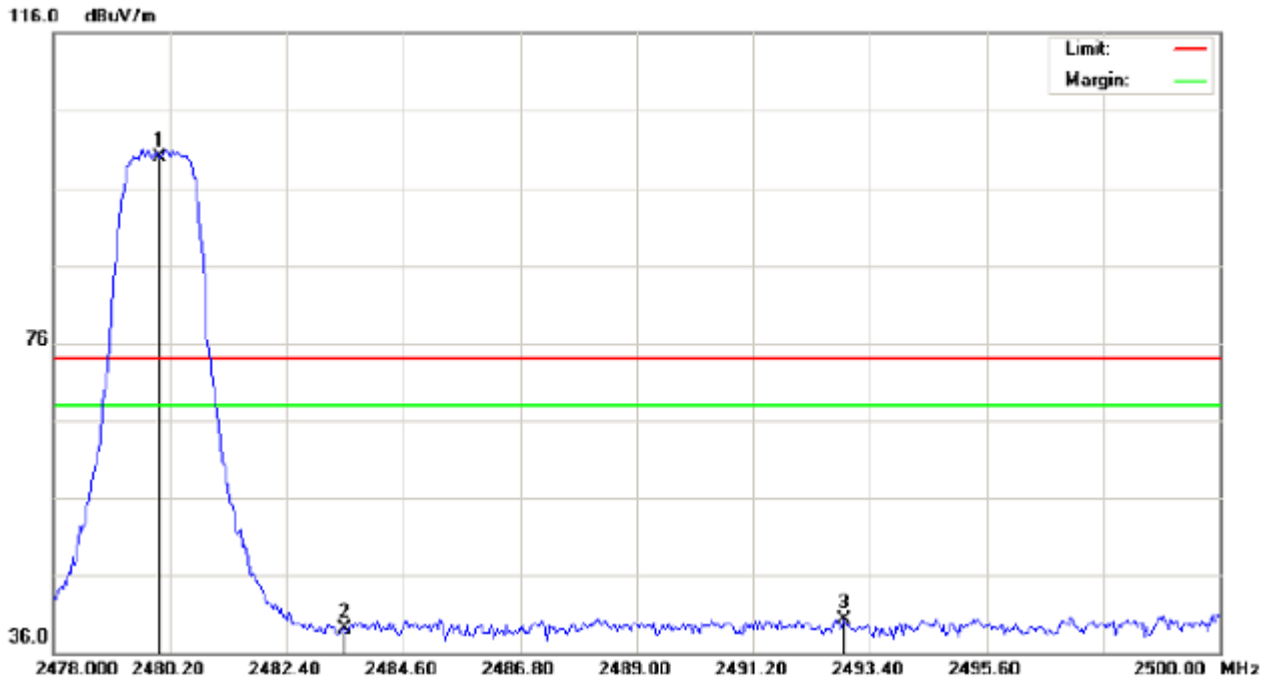

Site: site #1
Limit: FCC Class B 3M Radiation above 1GHZ(PK)
EUT: Wireless 2-in-1 Adapter
M/N: TT-BA07
Mode: High Channel TX
Note:

Polarization: *Horizontal*
Power:
Distance:

Temperature: 26
Humidity: 60 %

No.	Mk	Freq.	Reading	Factor	Measurement	Limit	Over	Detector	Antenna Height	Table Degree	Comment
		MHz	dBuV	dB/m	dBuV/m	dBuV/m	dB		cm	degree	
1	*	2480.000	89.55	10.41	99.96	74.00	25.96	peak			
2		2483.500	28.69	10.41	39.10	74.00	-34.90	peak			
3		2492.923	29.83	10.42	40.25	74.00	-33.75	peak			

TEST PLOT OF BAND EDGE FOR HIGH CHANNEL-Vertical

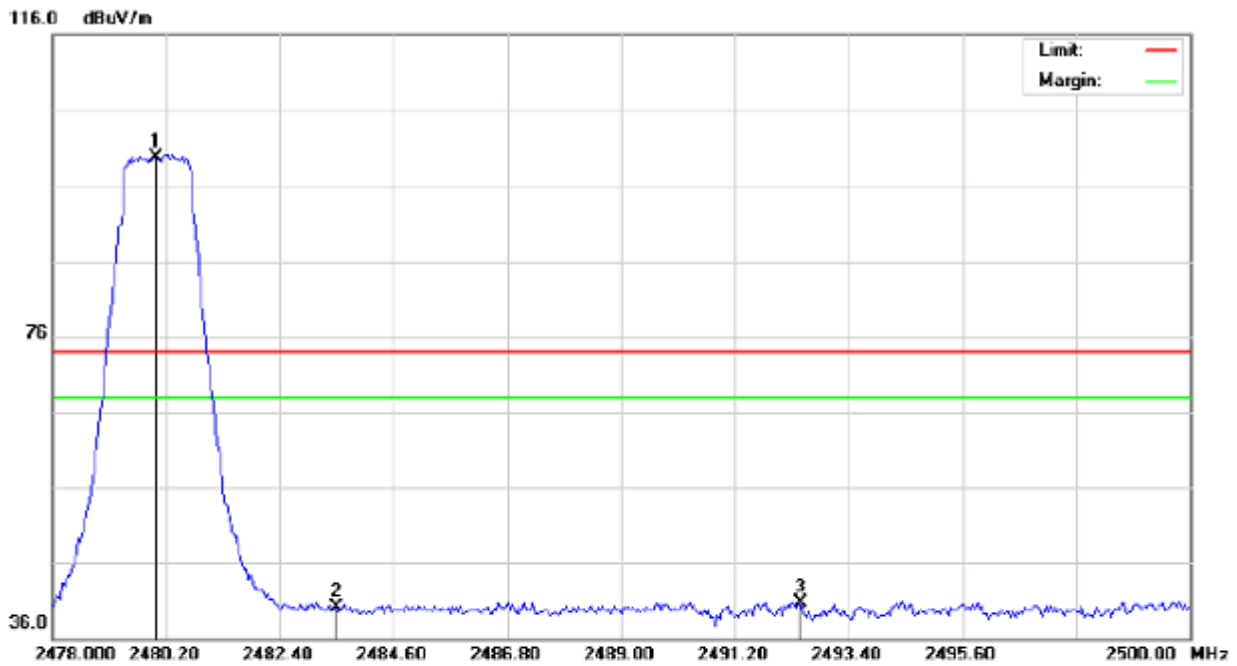

Site: site #1 Polarization: *Vertical* Temperature: 26
Limit: FCC Class B 3M Radiation above 1GHZ(PK) Power: Humidity: 60 %
EUT: Wireless 2-in-1 Adapter Distance:
M/N: TT-BA07
Mode: High Channel TX
Note:

No.	Mk	Freq.	Reading	Factor	Measurement	Limit	Over	Detector	Antenna Height	Table Degree	Comment
		MHz	dBuV	dB/m	dBuV/m	dBuV/m	dB		cm	degree	
1	*	2480.000	89.32	10.41	99.73	74.00	25.73	peak			
2		2483.500	29.76	10.41	40.17	74.00	-33.83	peak			
3		2492.483	30.36	10.42	40.78	74.00	-33.22	peak			

RESULT: PASS

Note: The other modes radiation emission have enough 20dB margin.

Factor=Antenna Factor + Cable loss - Amplifier gain, Over=Measure-Limit.

The "Factor" value can be calculated automatically by software of measurement system.

11. 20DB BANDWIDTH

11.1. MEASUREMENT PROCEDURE

1. Connect EUT RF output port to the Spectrum Analyzer through an RF attenuator
2. Set the EUT Work on the top, the middle and the bottom operation frequency individually.
3. Set Span = approximately 2 to 3 times the 20 dB bandwidth, centered on a hopping channel
RBW \geq 1% of the 20 dB bandwidth, VBW \geq RBW; Sweep = auto; Detector function = peak
4. Set SPA Trace 1 Max hold, then View.

11.2. TEST SET-UP

(BLOCK DIAGRAM OF CONFIGURATION)

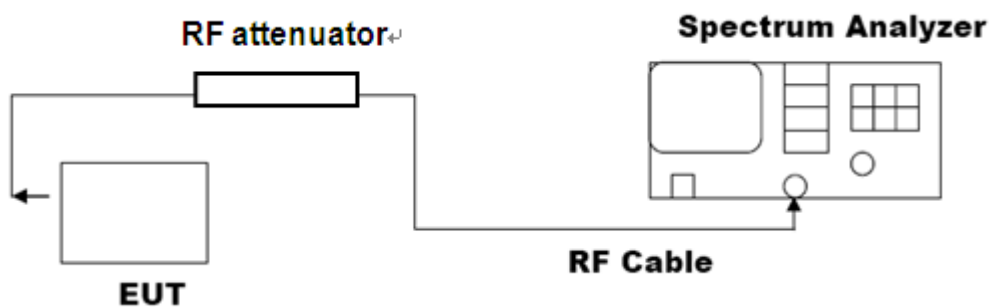

Note: The EUT has been used temporary antenna connector for testing.

11.3. LIMITS AND MEASUREMENT RESULTS

FOR BR/EDR

BLUETOOTH 1MBPS LIMITS AND MEASUREMENT RESULT			
Applicable Limits	Measurement Result		
	Test Data (MHz)		Criteria
N/A	Low Channel	1.093	PASS
	Middle Channel	1.086	PASS
	High Channel	1.075	PASS

TEST PLOT OF BANDWIDTH FOR LOW CHANNEL

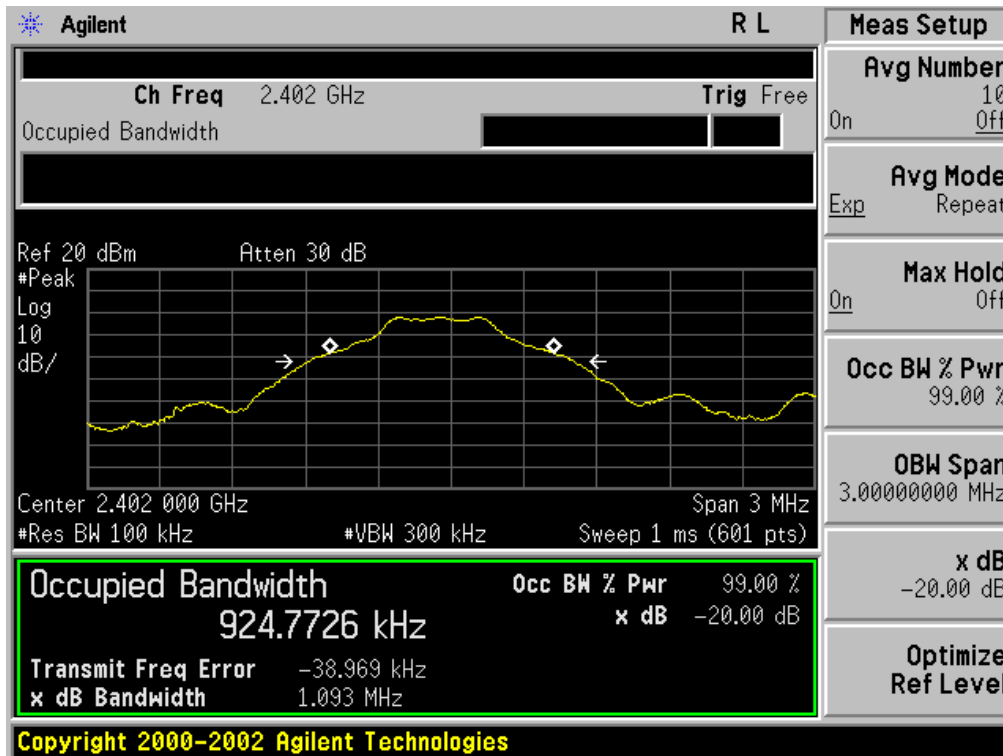

TEST PLOT OF BANDWIDTH FOR MIDDLE CHANNEL

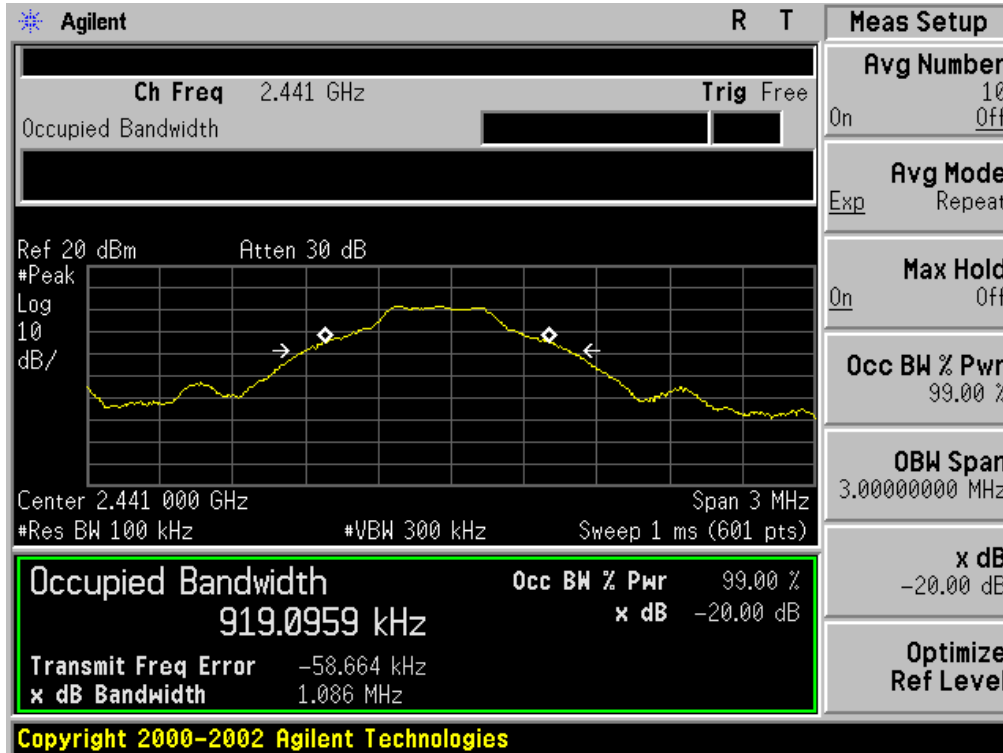

TEST PLOT OF BANDWIDTH FOR HIGH CHANNEL

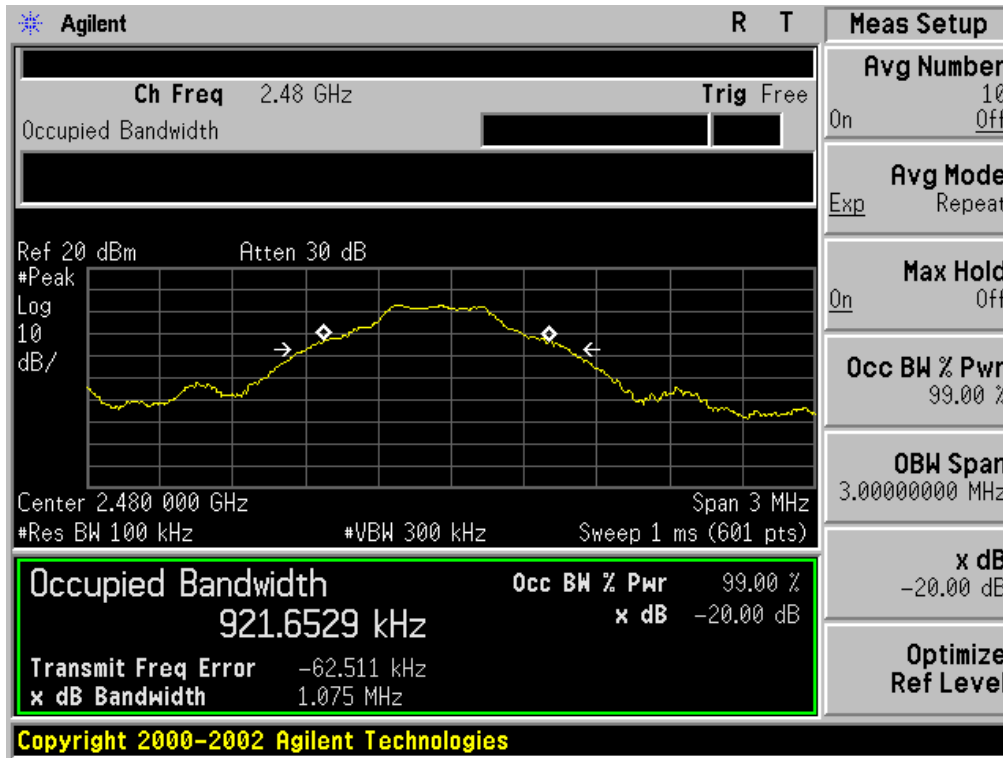

BLUETOOTH 2MBPS LIMITS AND MEASUREMENT RESULT			
Applicable Limits	Measurement Result		
	Test Data (MHz)		Criteria
N/A	Low Channel	1.379	PASS
	Middle Channel	1.383	PASS
	High Channel	1.374	PASS

TEST PLOT OF BANDWIDTH FOR LOW CHANNEL

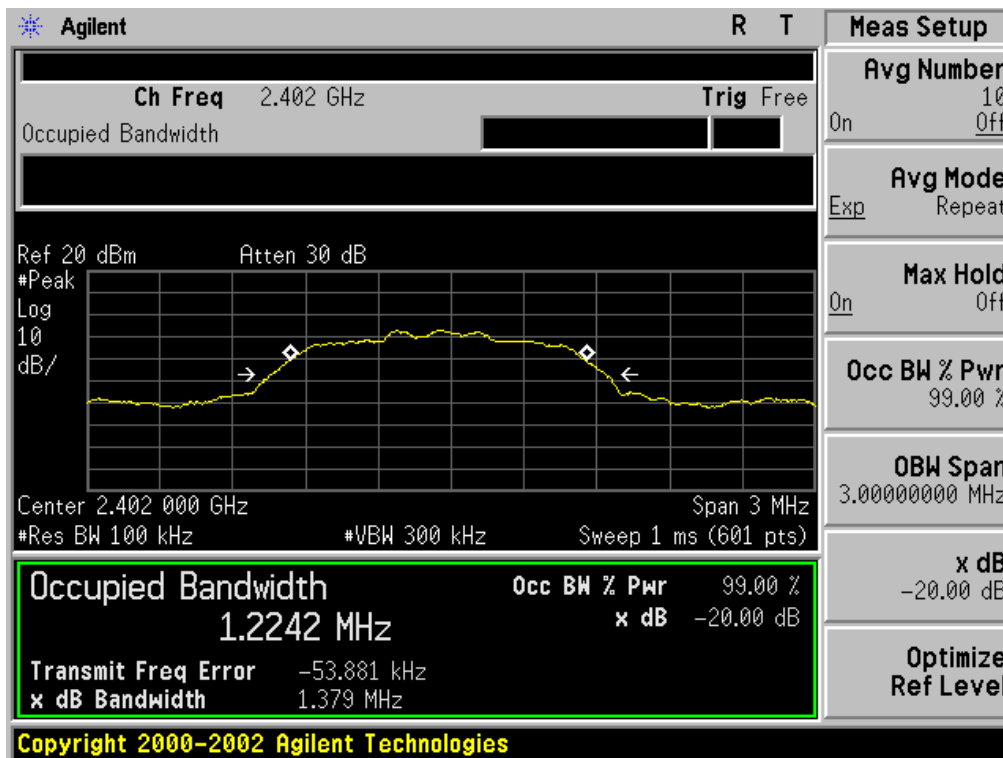

TEST PLOT OF BANDWIDTH FOR MIDDLE CHANNEL

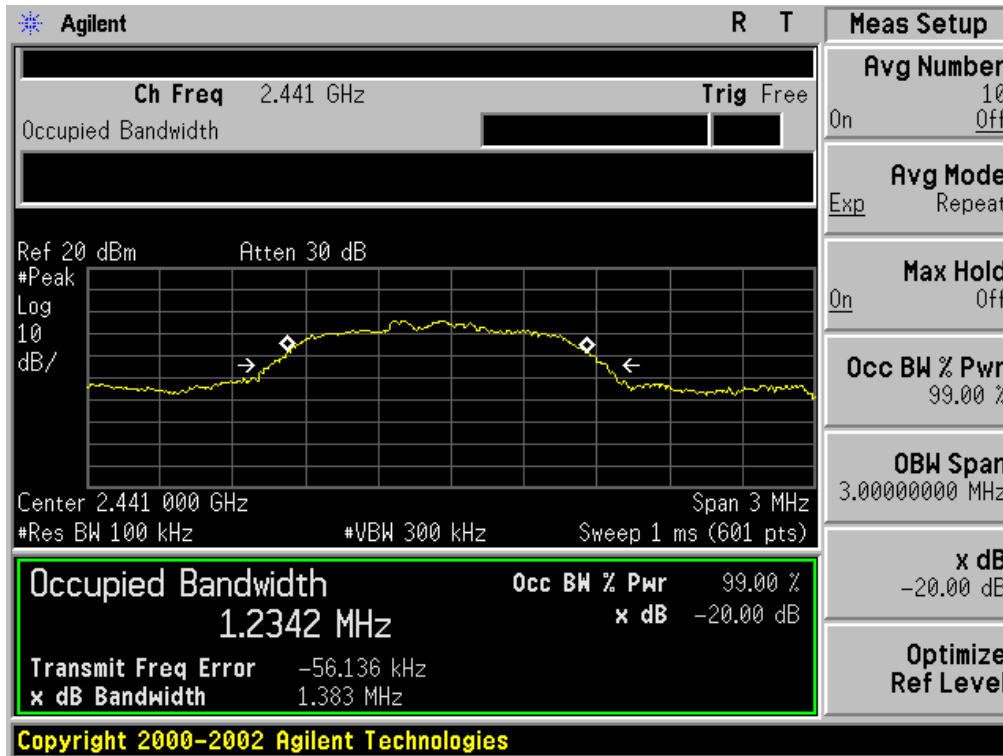

TEST PLOT OF BANDWIDTH FOR HIGH CHANNEL

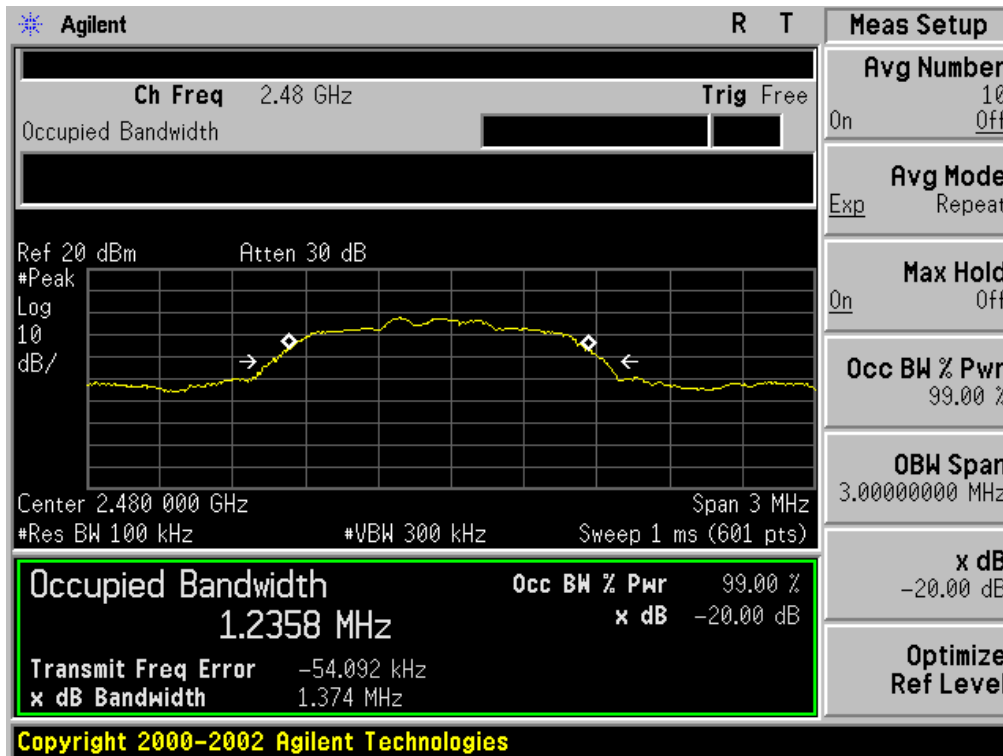

BLUETOOTH 3MBPS LIMITS AND MEASUREMENT RESULT			
Applicable Limits	Measurement Result		
	Test Data (MHz)		Criteria
N/A	Low Channel	1.378	PASS
	Middle Channel	1.358	PASS
	High Channel	1.360	PASS

TEST PLOT OF BANDWIDTH FOR LOW CHANNEL

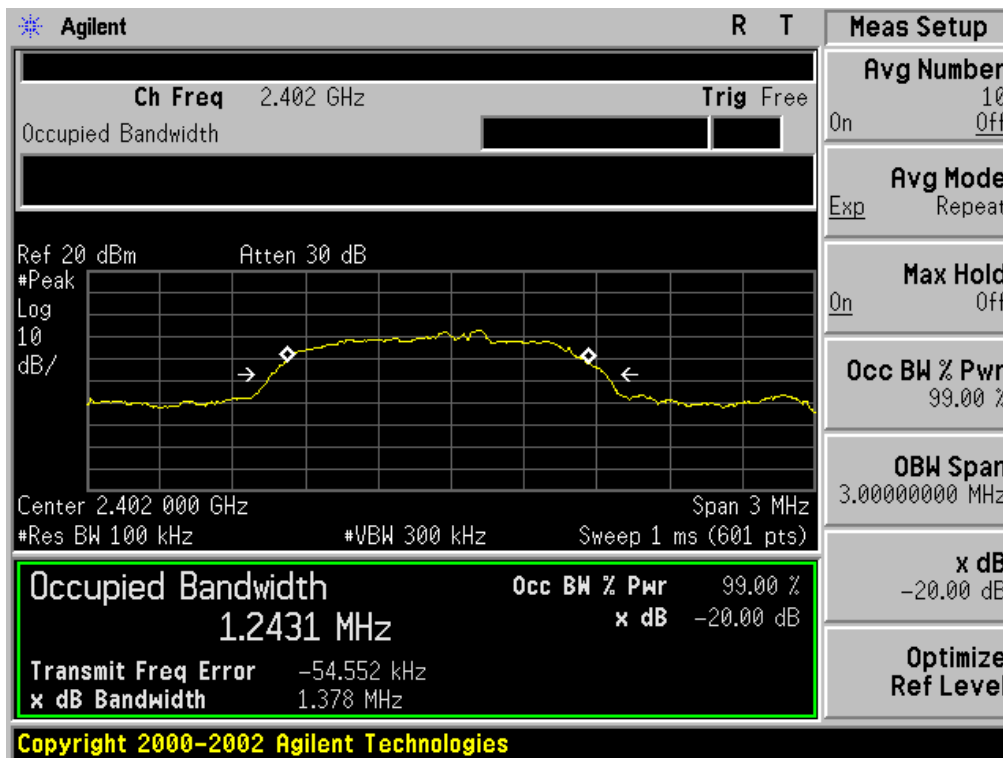

TEST PLOT OF BANDWIDTH FOR MIDDLE CHANNEL

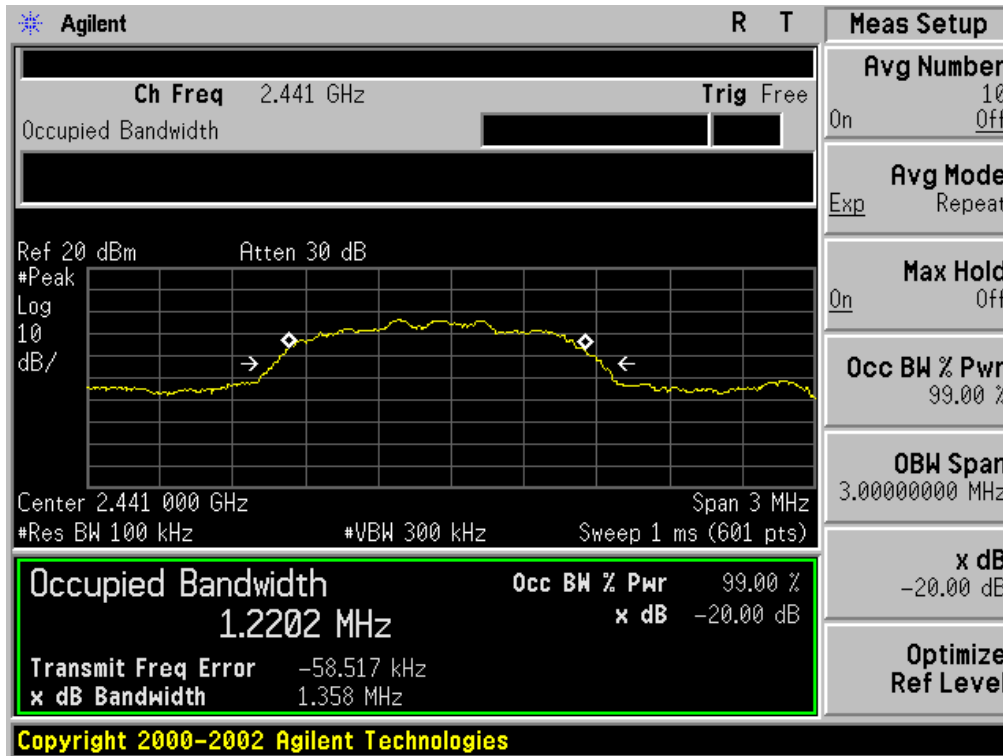

TEST PLOT OF BANDWIDTH FOR HIGH CHANNEL

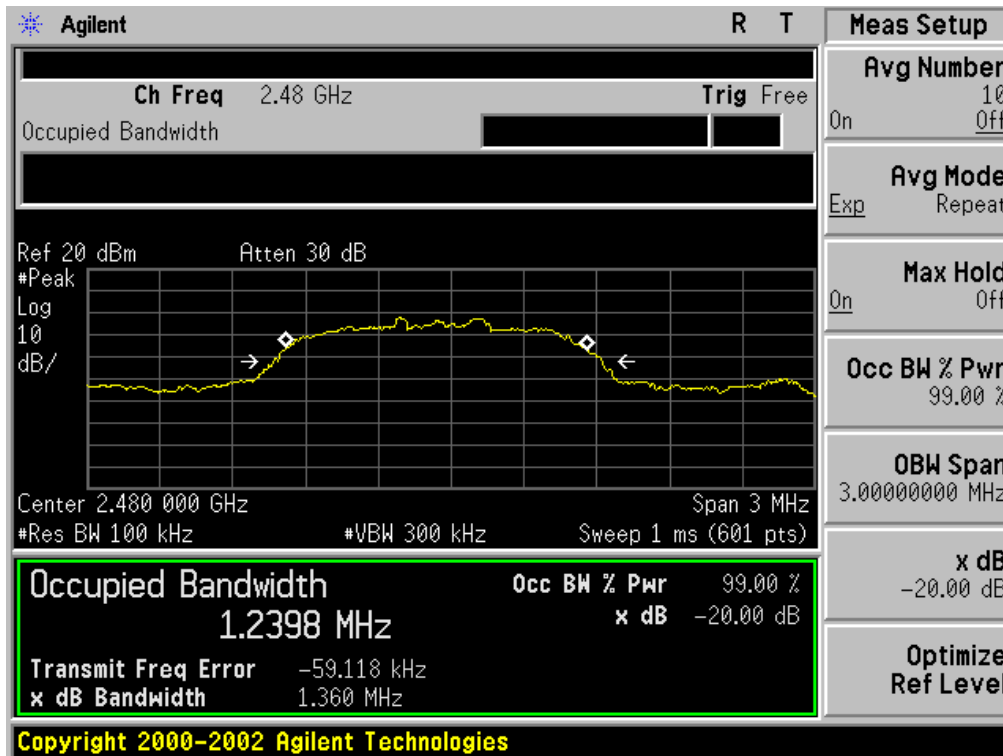

FOR BLE

BLUETOOTH 1MBPS LIMITS AND MEASUREMENT RESULT			
Applicable Limits	Measurement Result		
	Test Data (MHz)		Criteria
N/A	Low Channel	1.199	PASS
	Middle Channel	1.202	PASS
	High Channel	1.204	PASS

TEST PLOT OF BANDWIDTH FOR LOW CHANNEL

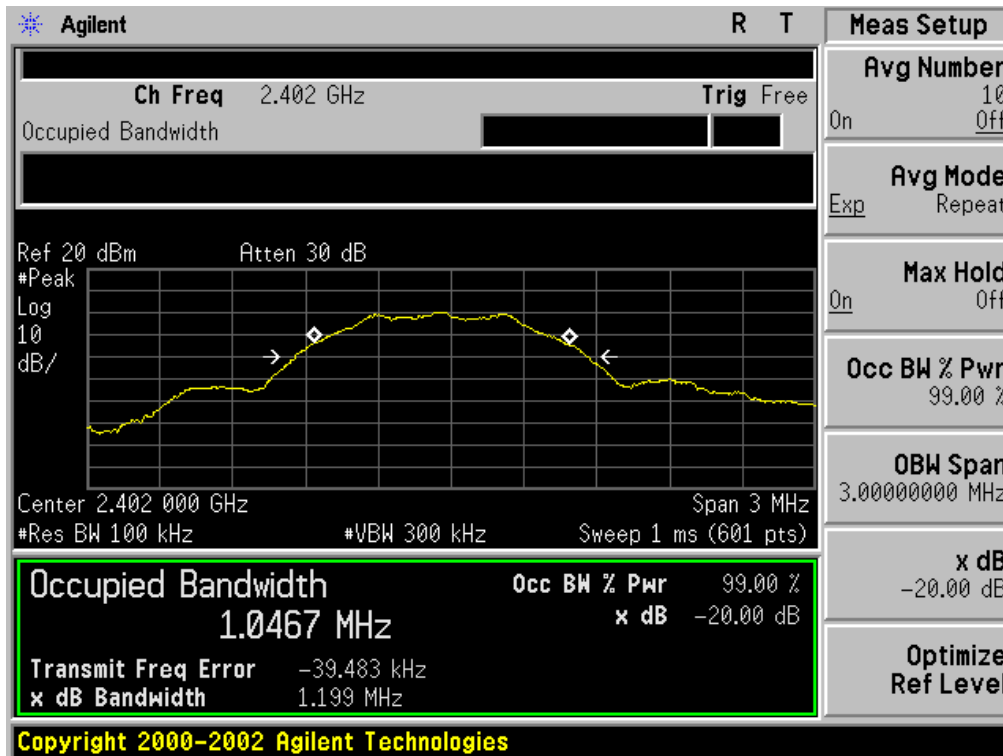

TEST PLOT OF BANDWIDTH FOR MIDDLE CHANNEL

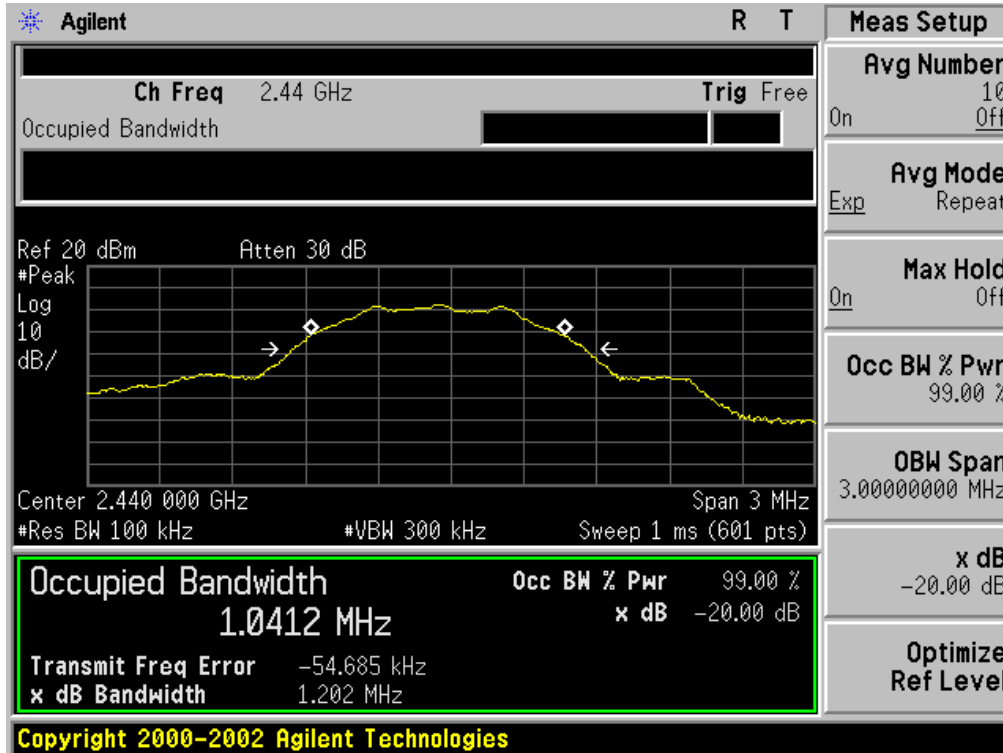

TEST PLOT OF BANDWIDTH FOR HIGH CHANNEL

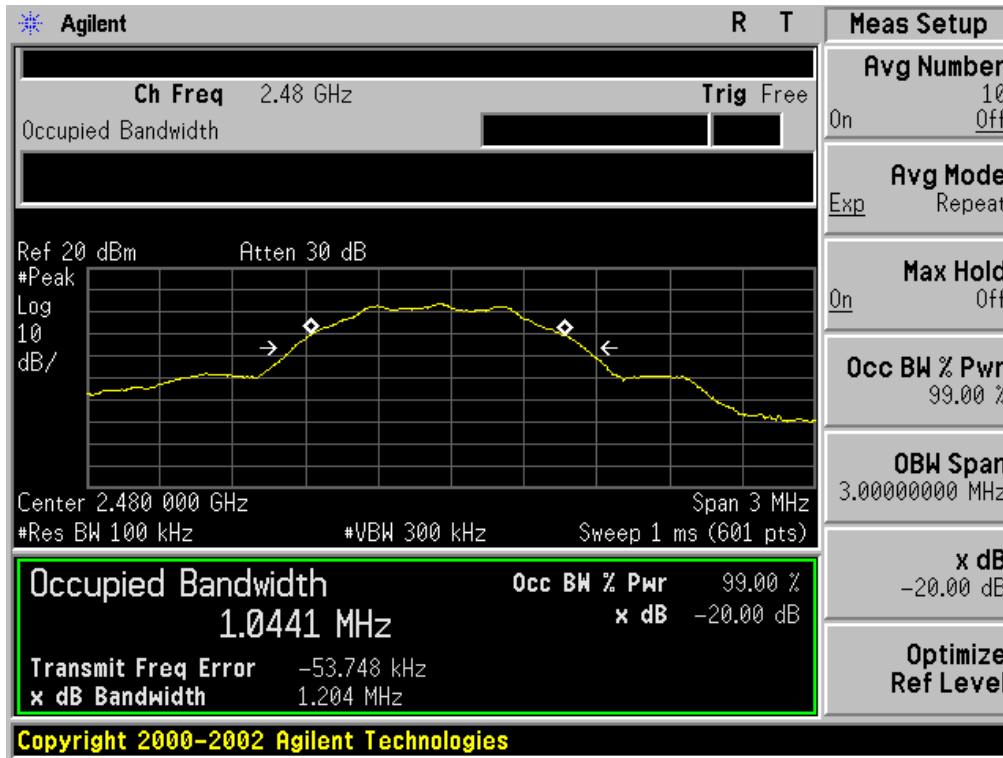

12. FCC LINE CONDUCTED EMISSION TEST

12.1. LIMITS OF LINE CONDUCTED EMISSION TEST

Frequency	Maximum RF Line Voltage	
	Q.P.(dBuV)	Average(dBuV)
150kHz~500kHz	66-56	56-46
500kHz~5MHz	56	46
5MHz~30MHz	60	50

Note:

1. The lower limit shall apply at the transition frequency.
2. The limit decreases linearly with the logarithm of the frequency in the range 0.15 MHz to 0.50 MHz.

12.2. BLOCK DIAGRAM OF LINE CONDUCTED EMISSION TEST

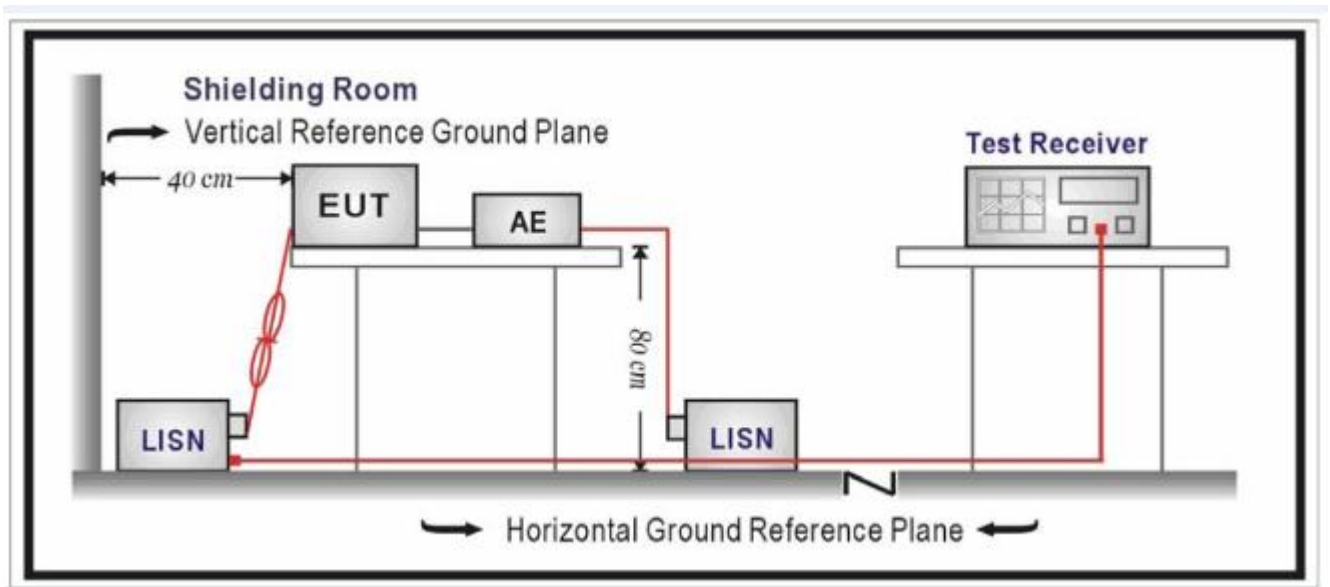

12.3. PRELIMINARY PROCEDURE OF LINE CONDUCTED EMISSION TEST

1. The equipment was set up as per the test configuration to simulate typical actual usage per the user's manual. When the EUT is a tabletop system, a wooden table with a height of 0.8 meters is used and is placed on the ground plane as per ANSI C63.10 (see Test Facility for the dimensions of the ground plane used). When the EUT is a floor-standing equipment, it is placed on the ground plane which has a 3-12 mm non-conductive covering to insulate the EUT from the ground plane.
2. Support equipment, if needed, was placed as per ANSI C63.10.
3. All I/O cables were positioned to simulate typical actual usage as per ANSI C63.10.
4. All support equipments received AC120V/60Hz power from a LISN, if any.
5. The EUT received DC charging voltage by PC or by adapter which received 120V/60Hz power by a LISN.
6. The test program was started. Emissions were measured on each current carrying line of the EUT using a spectrum Analyzer / Receiver connected to the LISN powering the EUT. The LISN has two monitoring points: Line 1 (Hot Side) and Line 2 (Neutral Side). Two scans were taken: one with Line 1 connected to Analyzer / Receiver and Line 2 connected to a 50 ohm load; the second scan had Line 1 connected to a 50 ohm load and Line 2 connected to the Analyzer / Receiver.
7. Analyzer / Receiver scanned from 150 kHz to 30MHz for emissions in each of the test modes.
8. During the above scans, the emissions were maximized by cable manipulation.
9. The test mode(s) were scanned during the preliminary test.

Then, the EUT configuration and cable configuration of the above highest emission level were recorded for reference of final testing.

12.4. FINAL PROCEDURE OF LINE CONDUCTED EMISSION TEST

- EUT and support equipment was set up on the test bench as per step 2 of the preliminary test.
2. A scan was taken on both power lines, Line 1 and Line 2, recording at least the six highest emissions. Emission frequency and amplitude were recorded into a computer in which correction factors were used to calculate the emission level and compare reading to the applicable limit. If EUT emission level was less -2dB to the A.V. limit in Peak mode, then the emission signal was re-checked using Q.P and Average detector.
3. The test data of the worst case condition(s) was reported..

**12.5. TEST RESULT OF LINE CONDUCTED EMISSION TEST
FOR BR/EDR
By Adapter (worst case)**

Line Conducted Emission Test Line 1-L

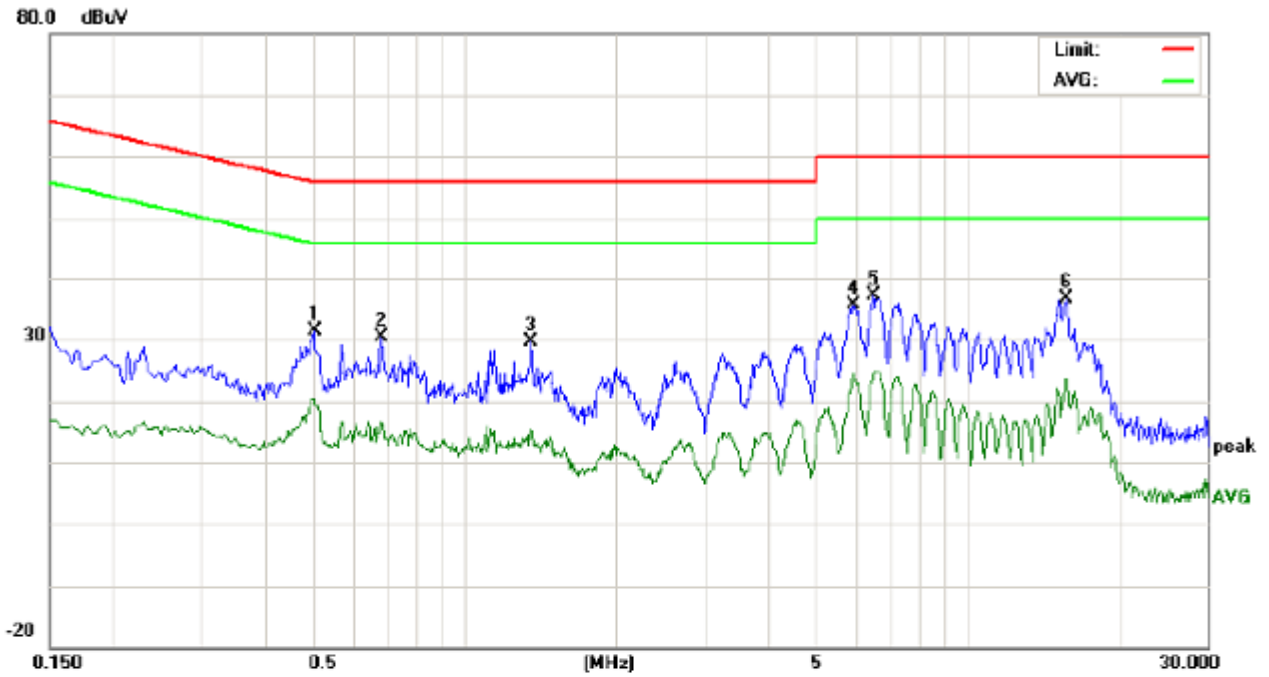

Site: Conduction Phase: **L1** Temperature: 23.9
 Limit: FCC Class B Conduction(QP) Power: Humidity: 55.2 %
 EUT: Wireless 2-in-1 Adapter
 M/N: TT-BA07
 Mode: TX with charging + phone
 Note:

No.	Freq. (MHz)	Reading_Level (dBuV)			Correct Factor	Measurement (dBuV)			Limit (dBuV)		Margin (dB)		P/F	Comment
		Peak	QP	AVG		dB	Peak	QP	AVG	QP	AVG	QP		
1	0.5020	21.05		10.10	10.40	31.45		20.50	56.00	46.00	-24.55	-25.50	P	
2	0.6860	19.96		6.21	10.34	30.30		16.55	56.00	46.00	-25.70	-29.45	P	
3	1.3540	19.34		4.90	10.38	29.72		15.28	56.00	46.00	-26.28	-30.72	P	
4	5.9540	25.42		13.97	10.28	35.70		24.25	60.00	50.00	-24.30	-25.75	P	
5	6.5140	26.81		13.56	10.30	37.11		23.86	60.00	50.00	-22.89	-26.14	P	
6	15.7260	26.50		13.42	10.11	36.61		23.53	60.00	50.00	-23.39	-26.47	P	

Line Conducted Emission Test Line 2-N

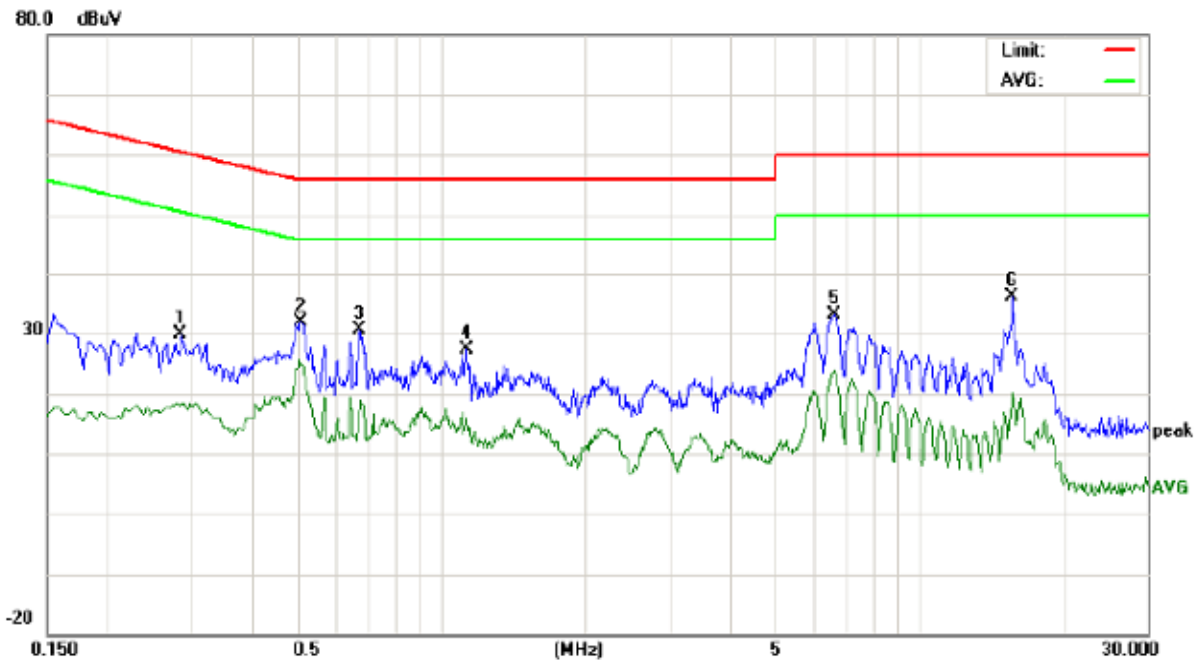

Site: Conduction Phase: **N** Temperature: 23.9
 Limit: FCC Class B Conduction(QP) Power: Humidity: 55.2 %
 EUT: Wireless 2-in-1 Adapter
 M/N: TT-BA07
 Mode: TX with charging + phone
 Note:

No.	Freq. (MHz)	Reading_Level (dBuV)			Correct Factor (dB)	Measurement (dBuV)			Limit (dBuV)		Margin (dB)		P/F	Comment
		Peak	QP	AVG		Peak	QP	AVG	QP	AVG	QP	AVG		
1	0.2860	19.67		8.04	10.28	29.95		18.32	60.64	50.64	-30.69	-32.32	P	
2	0.5100	21.41		14.60	10.39	31.80		24.99	56.00	46.00	-24.20	-21.01	P	
3	0.6740	20.39		5.70	10.34	30.73		16.04	56.00	46.00	-25.27	-29.96	P	
4	1.1260	16.91		4.92	10.37	27.28		15.29	56.00	46.00	-28.72	-30.71	P	
5	6.6380	22.85		13.51	10.32	33.17		23.83	60.00	50.00	-26.83	-26.17	P	
6	15.6620	25.91		9.96	10.11	36.02		20.07	60.00	50.00	-23.98	-29.93	P	

FOR BLE
By Adapter (worst case)

Line Conducted Emission Test Line 1-L

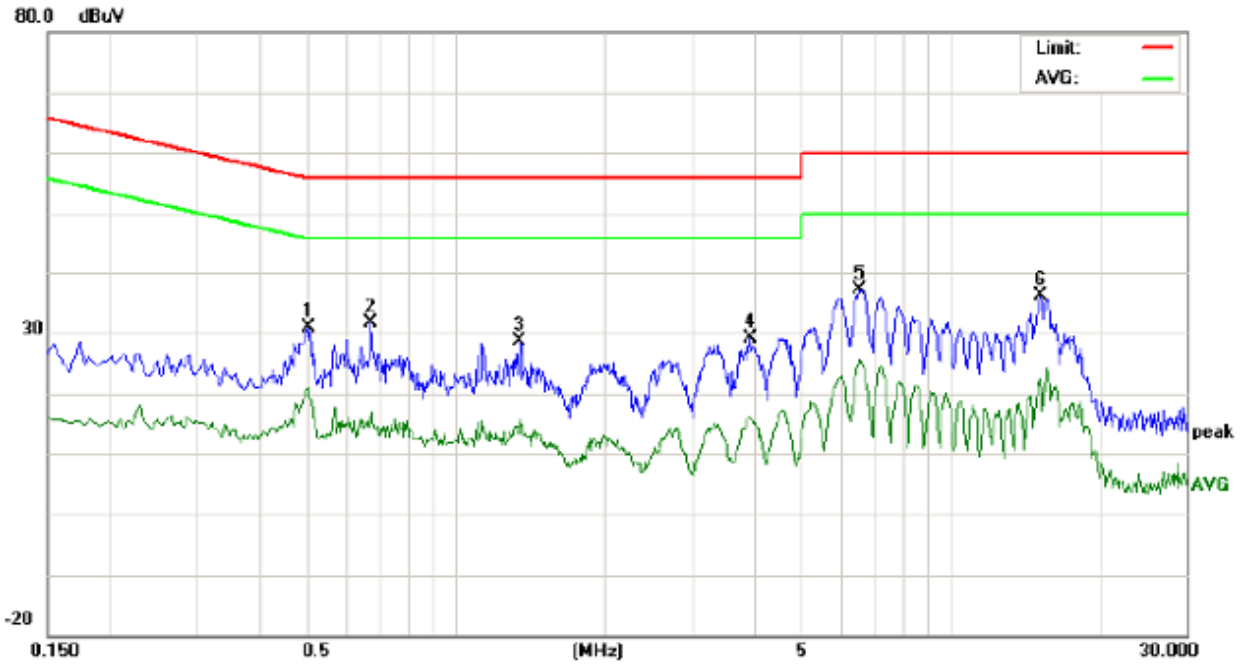

Site: Conduction Phase: **L1** Temperature: 23.9
 Limit: FCC Class B Conduction(QP) Power: Humidity: 55.2 %
 EUT: Wireless 2-in-1 Adapter
 M/N: TT-BA07
 Mode: TX with charging + phone
 Note:

No.	Freq. (MHz)	Reading_Level (dBuV)			Correct Factor (dB)	Measurement (dBuV)			Limit (dBuV)		Margin (dB)		P/F	Comment
		Peak	QP	AVG		Peak	QP	AVG	QP	AVG	QP	AVG		
1	0.5020	20.37		10.52	10.40	30.77		20.92	56.00	46.00	-25.23	-25.08	P	
2	0.6740	21.20		5.56	10.34	31.54		15.90	56.00	46.00	-24.46	-30.10	P	
3	1.3460	18.37		5.24	10.38	28.75		15.62	56.00	46.00	-27.25	-30.38	P	
4	3.9340	18.79		5.65	10.44	29.23		16.09	56.00	46.00	-26.77	-29.91	P	
5	6.5500	26.91		14.90	10.31	37.22		25.21	60.00	50.00	-22.78	-24.79	P	
6	15.1540	25.89		12.25	10.12	36.01		22.37	60.00	50.00	-23.99	-27.63	P	

Line Conducted Emission Test Line 2-N

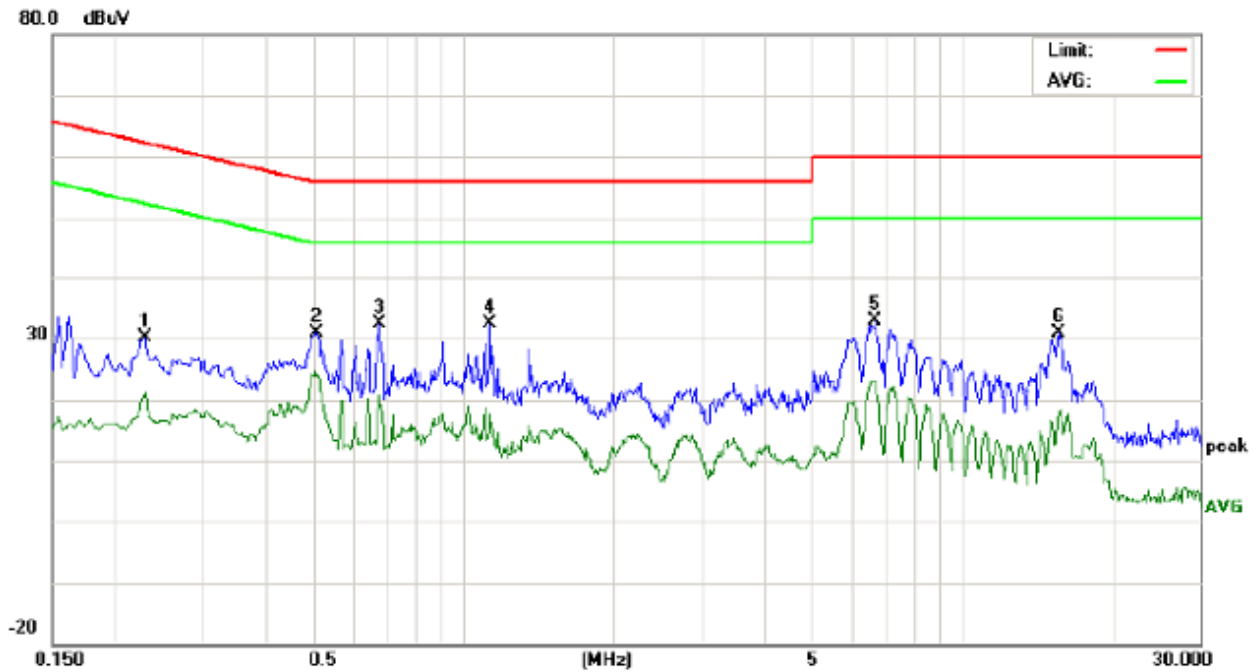

Site: Conduction Phase: **N** Temperature: 23.9
 Limit: FCC Class B Conduction(QP) Power: Humidity: 55.2 %
 EUT: Wireless 2-in-1 Adapter
 M/N: TT-BA07
 Mode: TX with charging + phone
 Note:

No.	Freq. (MHz)	Reading Level (dBuV)			Correct Factor (dB)	Measurement (dBuV)			Limit (dBuV)		Margin (dB)		P/F	Comment
		Peak	QP	AVG		Peak	QP	AVG	QP	AVG	QP	AVG		
1	0.2300	19.95		10.91	10.25	30.20		21.16	62.45	52.45	-32.25	-31.29	P	
2	0.5100	20.60		13.52	10.39	30.99		23.91	56.00	46.00	-25.01	-22.09	P	
3	0.6780	22.08		10.33	10.34	32.42		20.67	56.00	46.00	-23.58	-25.33	P	
4	1.1340	22.05		7.37	10.37	32.42		17.74	56.00	46.00	-23.58	-28.26	P	
5	6.7100	22.61		12.06	10.33	32.94		22.39	60.00	50.00	-27.06	-27.61	P	
6	15.7020	20.82		8.07	10.11	30.93		18.18	60.00	50.00	-29.07	-31.82	P	

APPENDIX A: PHOTOGRAPHS OF TEST SETUP
FCC LINE CONDUCTED EMISSION TEST SETUP



FCC RADIATED EMISSION TEST SETUP

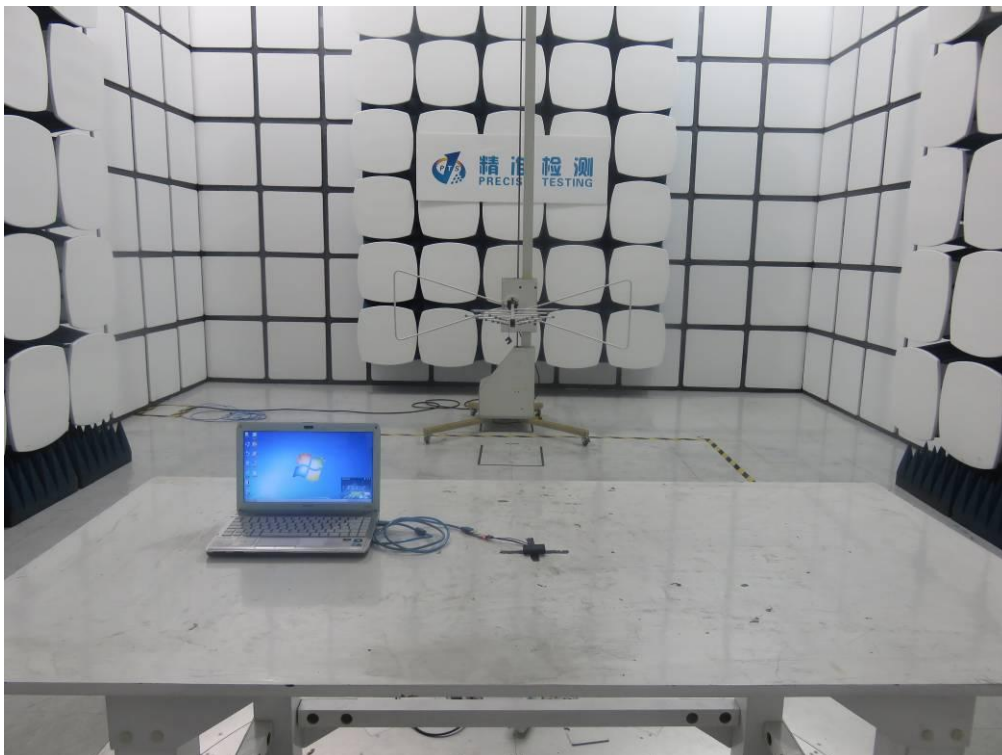



APPENDIX B: PHOTOGRAPHS OF EUT

WHOLE VIEW OF EUT



TOP VIEW OF EUT



BOTTOM VIEW OF EUT

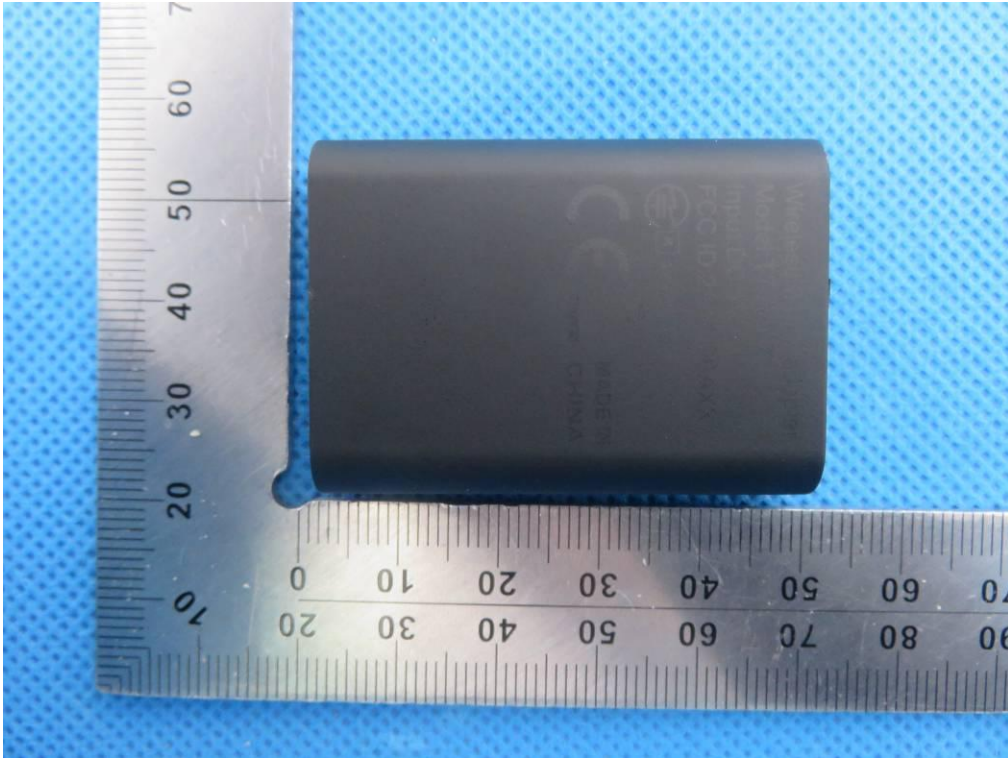

FRONT VIEW OF EUT

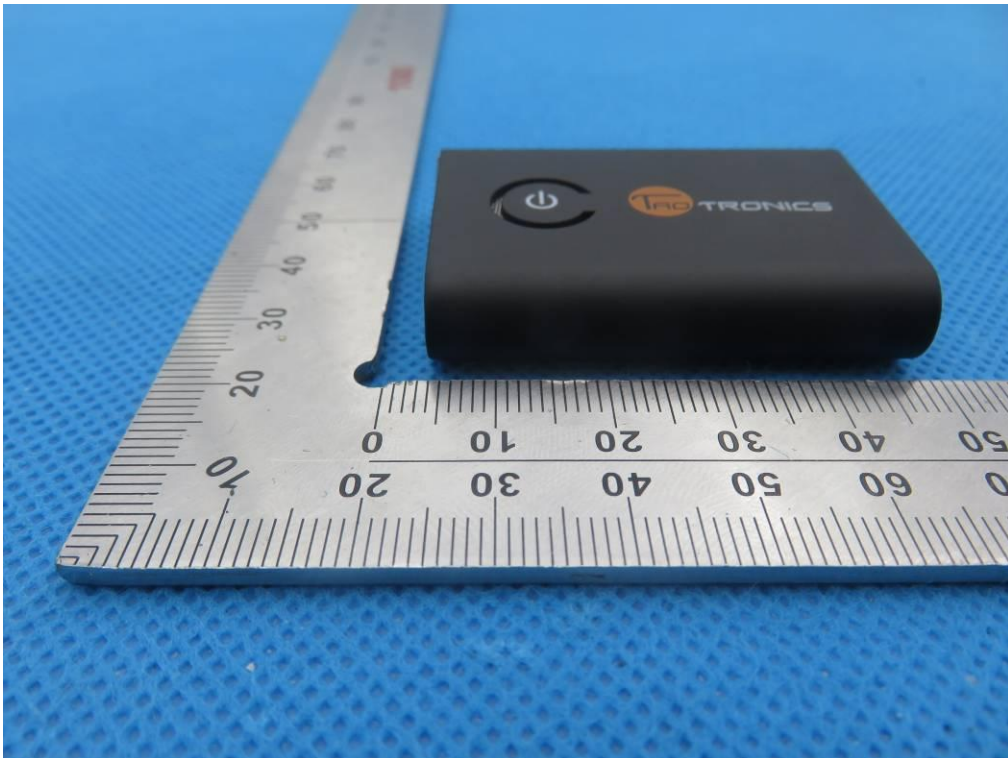

BACK VIEW OF EUT

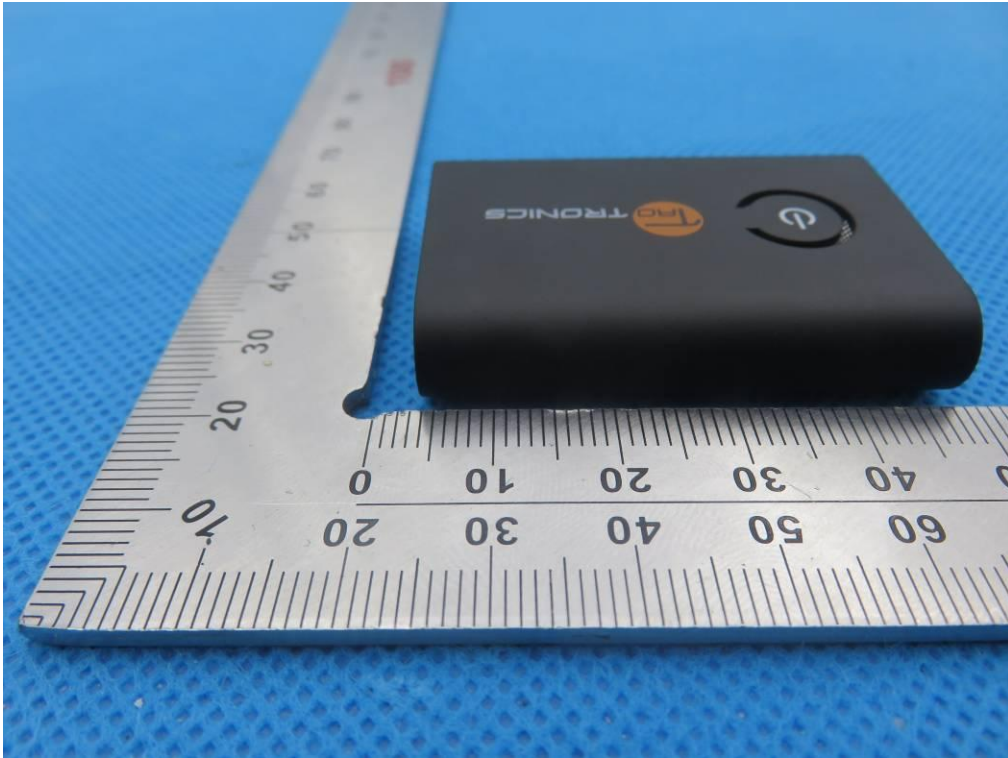

LEFT VIEW OF EUT

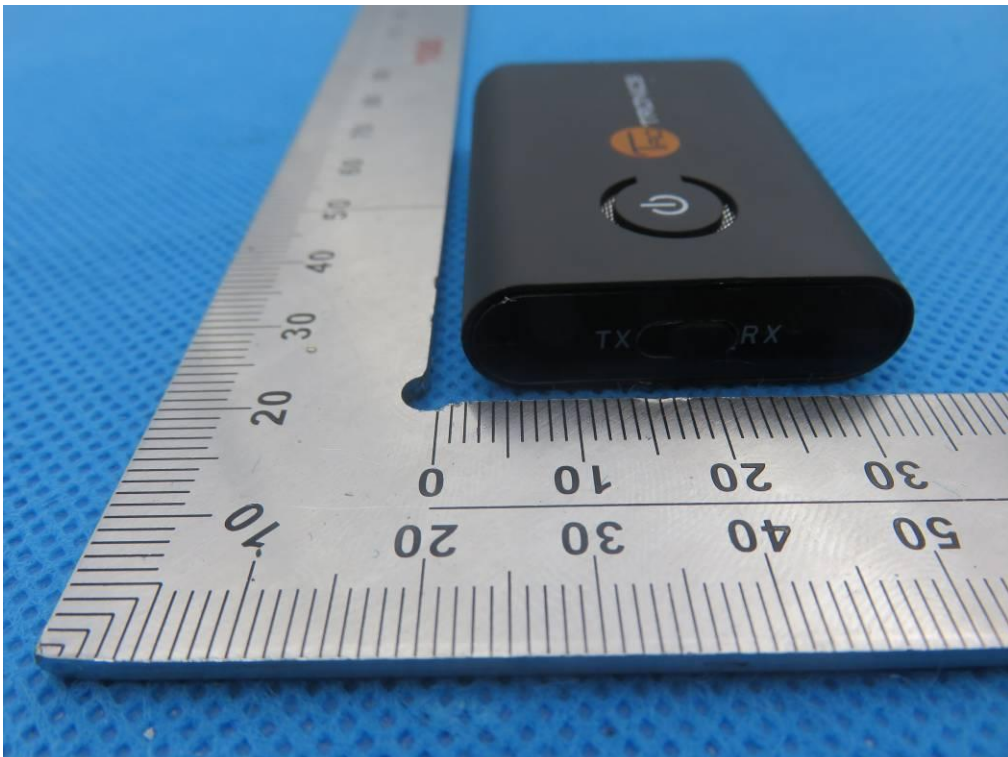

RIGHT VIEW OF EUT

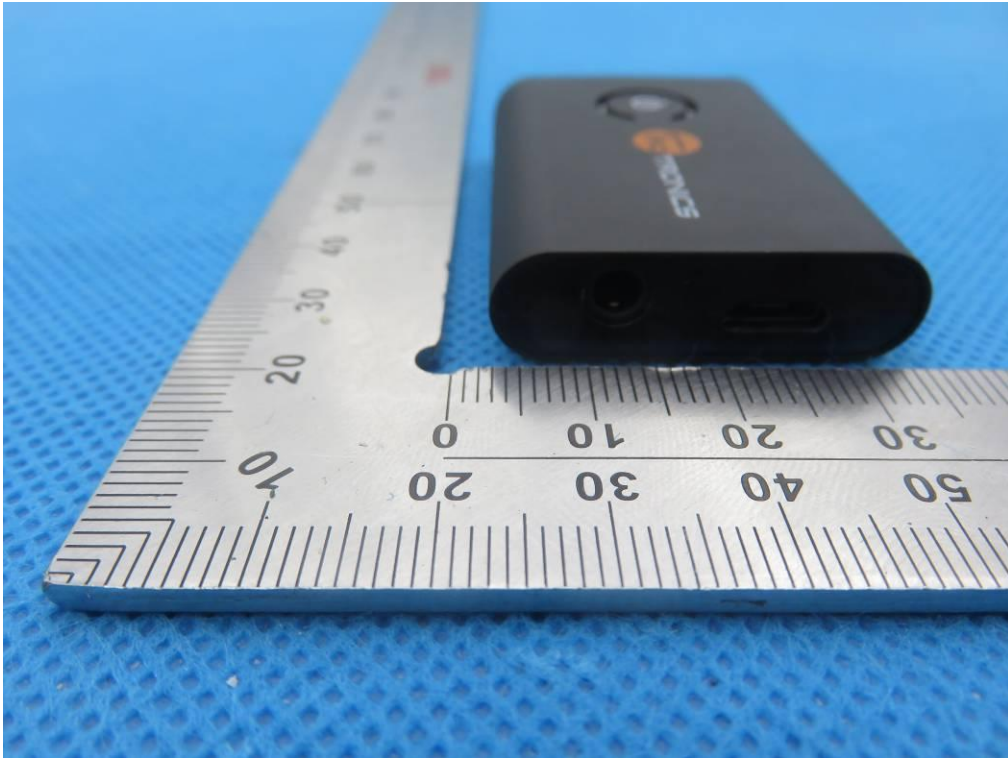

VIEW OF EUT (PORT)



VIEW OF EUT (OPEN)

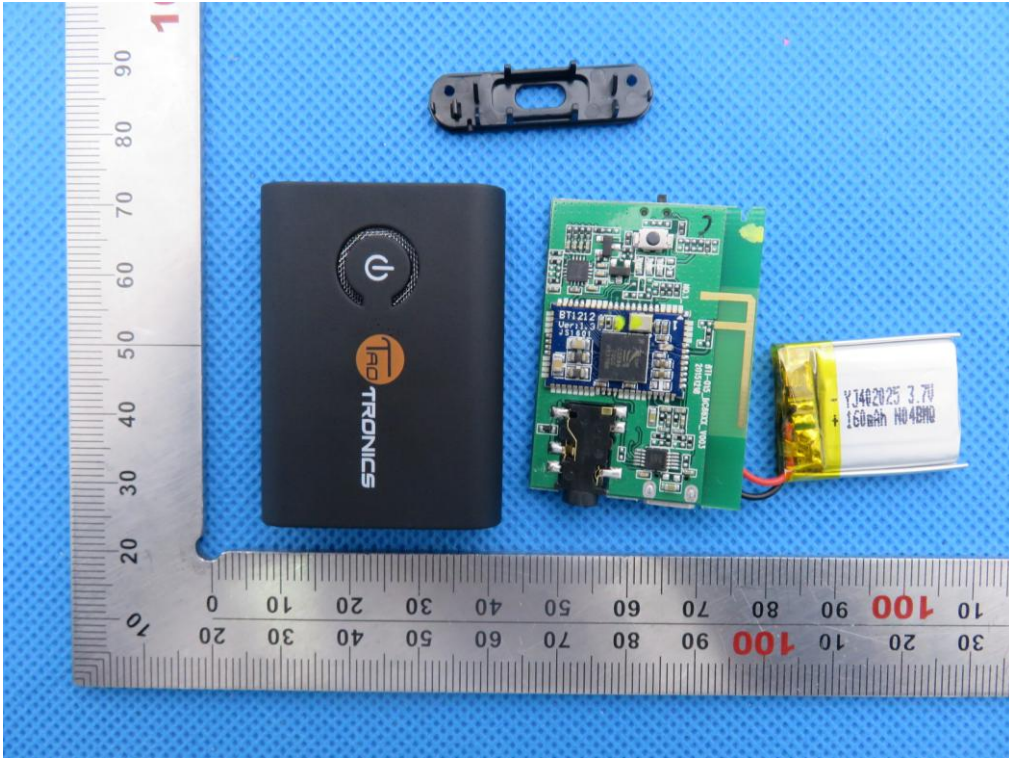

INTERNAL VIEW OF EUT-1

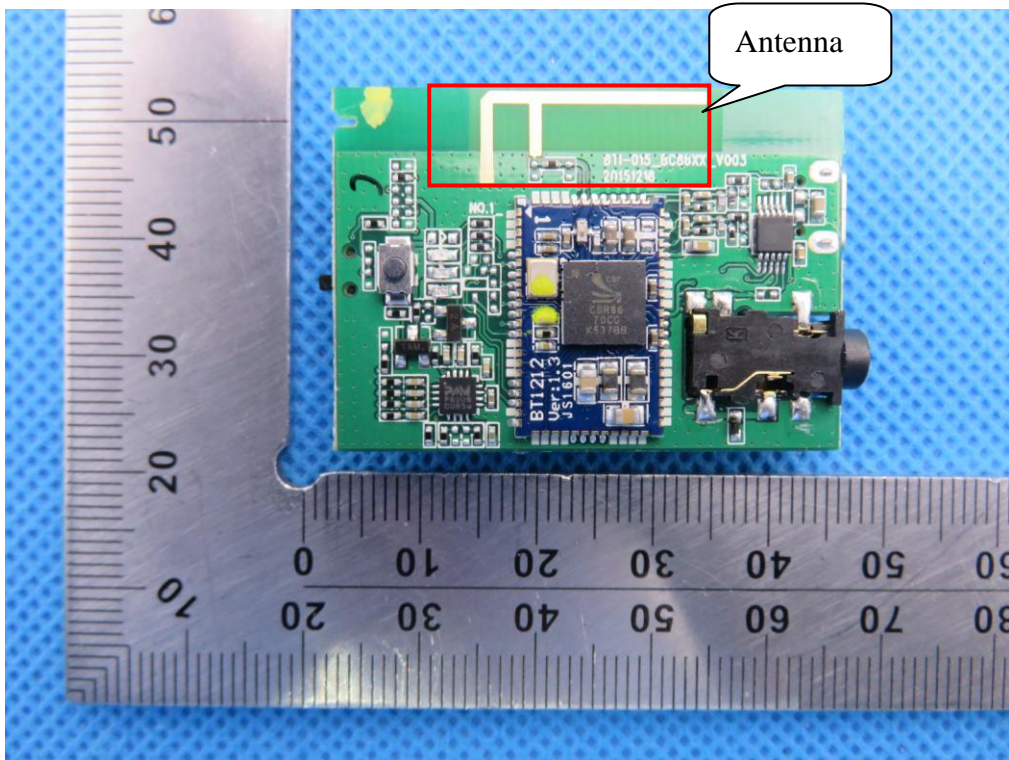

INTERNAL VIEW OF EUT-2

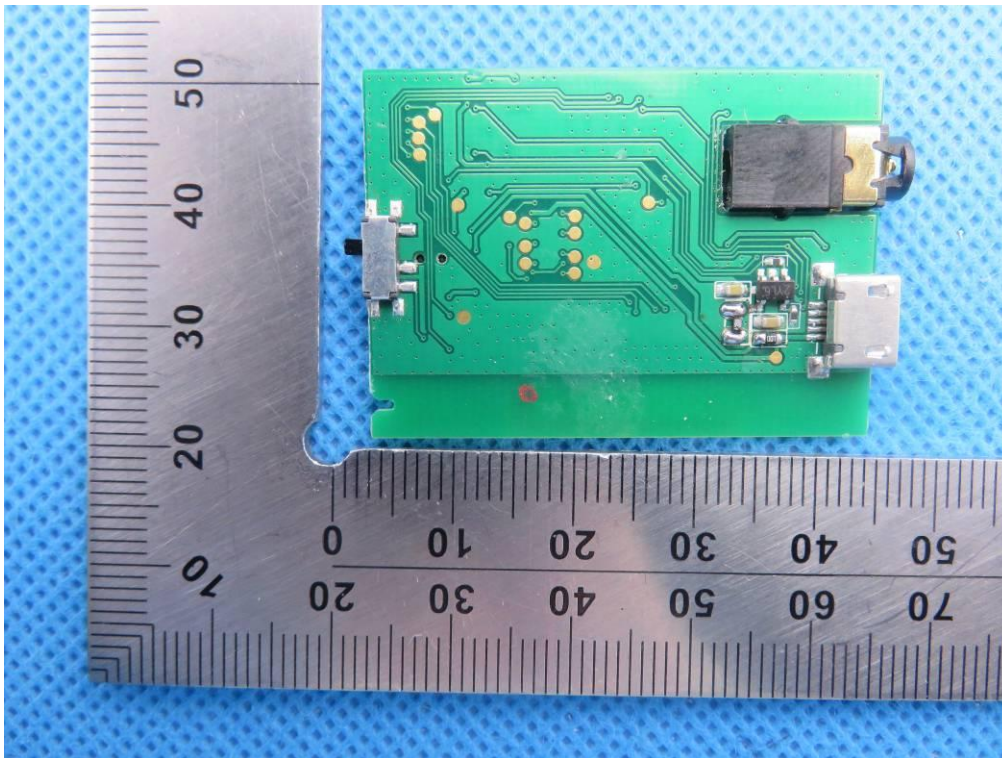

INTERNAL VIEW OF EUT-4

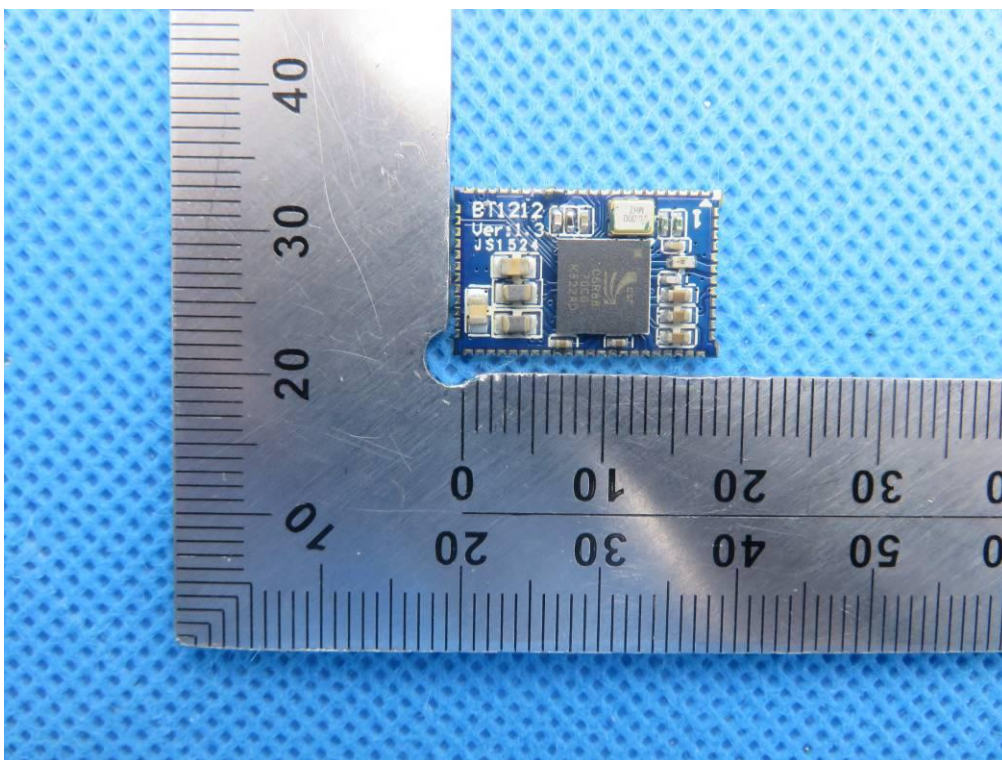

INTERNAL VIEW OF EUT-5

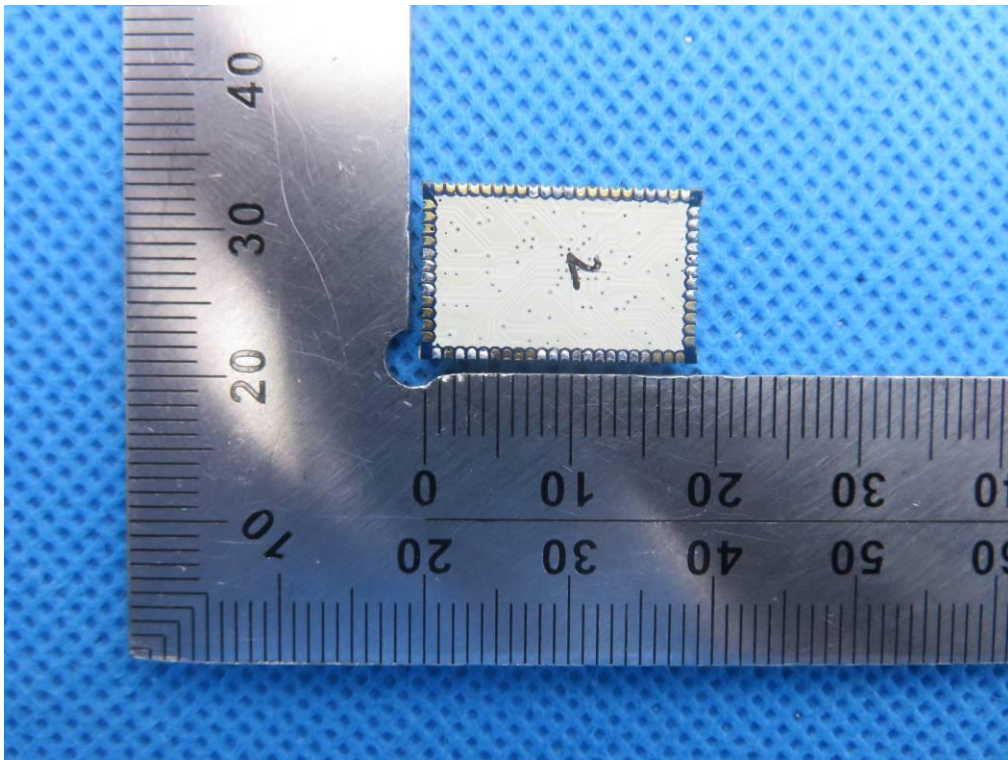

----END OF REPORT----