

**ELECTROMAGNETIC EMISSIONS COMPLIANCE REPORT
INTENTIONAL RADIATOR CERTIFICATION TO
FCC PART 15 SUBPART C REQUIREMENT**

OF

Wireless Speakers

Model No.: DALI ZENSOR 1 AX, DALI ZENSOR 5 AX

Trademark: DALI

FCC ID: 2AFD2-ZENSOR

Report No.: KAD150629097E2

Issue Date: October 21, 2015

Prepared for

DALI A/S

Dali Allé 1, DK-9610, Noerager, Denmark

Prepared by

DONGGUAN EMTEK CO., LTD.

**No.281, Guantai Road, Nancheng District,
Dongguan, Guangdong, China**

TEL: 86-769-22807078

FAX: 86-769-22807079

**This report shall not be reproduced, except in full, without the written approval of
DONGGUAN EMTEK CO., LTD.**

VERIFICATION OF COMPLIANCE

Applicant:	DALI A/S Dali Allé 1, DK-9610, Noerager, Denmark
Manufacturer:	DALI AUDIO MANUFACTURING(NINGBO)CO.,LTD Building 7 No.1188, Zhongguan Road Ningbo zhejiang Province
Product Description:	Wireless Speakers
Trade Mark:	DALI
Model Number:	DALI ZENSOR 1 AX, DALI ZENSOR 5 AX (Note: The samples are the same except model number. So DALI ZENSOR 5 AX was selected for full test.)

We hereby certify that:

The above equipment was tested by DONGGUAN EMTEK CO., LTD. The test data, data evaluation, test procedures, and equipment configurations shown in this report were made in accordance with the procedures given in ANSI C63.10 (2013) and the energy emitted by the sample EUT tested as described in this report is in compliance with conducted and radiated emission limits of FCC Rules Part 15.247(2015).

Date of Test : June 29, 2015 to September 09, 2015

Prepared by : 
Ivy Huang/Editor

Reviewer : 
Alan He/Supervisor

Approved & Authorized Signer : 
Sam Lv/Manager

Modified Information

Version	Summary	Revision Date	Report No.
Ver.1.0	Original Report	/	KAD150629097E2

Table of Contents

1. GENERAL INFORMATION	6
1.1 PRODUCT DESCRIPTION	6
2. TEST FACILITY	7
3. DESCRIPTION OF TEST MODES	8
4. TEST SYSTEM UNCERTAINTY.....	9
5. CONDUCTED EMISSIONS TEST	10
5.1 MEASUREMENT PROCEDURE:.....	10
5.2 TEST SET-UP (BLOCK DIAGRAM OF CONFIGURATION)	10
5.3 MEASUREMENT EQUIPMENT USED:	10
5.4 CONDUCTED EMISSION LIMIT	10
5.5 MEASUREMENT RESULT:.....	10
4.6 CONDUCTED MEASUREMENT PHOTOS:	15
6. RADIATED EMISSION TEST.....	16
5.1 MEASUREMENT PROCEDURE.....	16
5.2 TEST SET-UP (BLOCK DIAGRAM OF CONFIGURATION)	17
5.3 MEASUREMENT EQUIPMENT USED:	18
5.4 RADIATED EMISSION LIMIT	19
5.5 MEASUREMENT RESULT	20
5.6 RADIATED MEASUREMENT PHOTOS:	26
7. 6DB BANDWIDTH MEASUREMENT	27
6.1 MEASUREMENT PROCEDURE.....	27
6.2 TEST SET-UP (BLOCK DIAGRAM OF CONFIGURATION)	27
6.3 MEASUREMENT EQUIPMENT USED:	27
6.4 LIMIT.....	27
6.5 MEASUREMENT RESULTS:.....	27
7. MAXIMUM PEAK OUTPUT POWER TEST	30
7.1 MEASUREMENT PROCEDURE.....	30
7.2 TEST SET-UP (BLOCK DIAGRAM OF CONFIGURATION)	30
7.3 MEASUREMENT EQUIPMENT USED:	30
7.4 PEAK POWER OUTPUT LIMIT	30
7.5 MEASUREMENT RESULTS:.....	30
8. POWER SPECTRAL DENSITY MEASUREMENT.....	33
8.1 MEASUREMENT PROCEDURE	33
8.2 TEST SET-UP (BLOCK DIAGRAM OF CONFIGURATION).....	33
8.3 MEASUREMENT EQUIPMENT USED:	33
8.4 MEASUREMENT PROCEDURE	33

8.5 MEASUREMENT RESULTS:..... 34

9. BAND EDGE TEST.....38

9.1 MEASUREMENT PROCEDURE 38

9.2 TEST SET-UP (BLOCK DIAGRAM OF CONFIGURATION) 38

9.3 MEASUREMENT EQUIPMENT USED: 39

9.4 MEASUREMENT RESULTS:..... 39

10 ANTENNA APPLICATION41

10.1 ANTENNA REQUIREMENT41

10.2 RESULT41

1. GENERAL INFORMATION

1.1 Product Description

Product Name	Wireless Speakers	
Model number	DALI ZENSOR 5 AX	
Power Supply	AC 100-240V, 50W	
Product Software Version	V.5.0	
Product Hardware version	V.A2	
Radio Software Version	V2.02	
Radio Hardware version	V.B1	
Test Software Version	V1.0	
RF Power Setting in Test Software	0dbm	
Technical Description		
	Bluetooth 4.0	Bluetooth 2.1+EDR
Operation Frequency	2402-2480MHz	
Modulation	GFSK	GFSK, $\pi/4$ -DQPSK, 8DPSK
Number of Channel	40	79
Channel space	2MHz	1MHz
Max RF Output Power	5.48dBm(0.003532W)	5.31dBm(0.003396W)
Antenna Type	Internal PCB antenna	
Antenna Gain	0 dBi	

2. Test Facility

Site Description

EMC Lab. : Registered on FCC, June 18, 2014
The Certificate Number is 247565

Registered on Industry Canada, February 19, 2014
The Certificate Number is 9444A.

Name of Firm : DONGGUAN EMTEK CO., LTD

Site Location : No.281, Guantai Road, Nancheng District,
Dongguan, Guangdong, China

3. Description of test modes

The EUT has been tested under its typical operating condition. Pre-defined engineering program for regulatory testing used to control the EUT for staying in continuous transmitting. Only the worst case data were reported.

The details of test channels and bandwidth were for RF conductive measurement.

Channel List:

Channel	Frequency (MHz)	Channel	Frequency (MHz)	Channel	Frequency (MHz)
00	2402	14	2430	28	2458
01	2404	15	2432	29	2460
02	2406	16	2434	30	2462
03	2408	17	2436	31	2464
04	2410	18	2438	32	2466
05	2412	19	2440	33	2468
06	2414	20	2442	34	2470
07	2416	21	2444	35	2472
08	2418	22	2446	36	2474
09	2420	23	2448	37	2476
10	2422	24	2450	38	2478
11	2424	25	2452	39	2480
12	2426	26	2454		
13	2428	27	2456		

Note:

1. Test of channel was included the lowest 2402MHz, middle 2442MHz and highest frequency 2480MHz in highest data rate and to perform the test, then record on this report.

4. TEST SYSTEM UNCERTAINTY

The following measurement uncertainty levels have been estimated for tests performed on the apparatus:

Parameter	Uncertainty
Radio Frequency	$\pm 1 \times 10^{-5}$
Maximum Peak Output Power Test	$\pm 1.0\text{dB}$
Conducted Emissions Test	$\pm 2.0\text{dB}$
Radiated Emission Test	$\pm 2.0\text{dB}$
Power Density	$\pm 2.0\text{dB}$
Occupied Bandwidth Test	$\pm 1.0\text{dB}$
Band Edge Test	$\pm 3\text{dB}$
All emission, radiated	$\pm 3\text{dB}$
Antenna Port Emission	$\pm 3\text{dB}$
Temperature	$\pm 0.5^\circ\text{C}$
Humidity	$\pm 3\%$

Measurement Uncertainty for a level of Confidence of 95%

5. Conducted Emissions Test

5.1 Measurement Procedure:

1. The EUT was placed on a table, which is 0.1m above ground plane.
2. Maximum procedure was performed on the six highest emissions to ensure EUT compliance.
3. Repeat above procedures until all frequency measured was complete.

5.2 Test SET-UP (Block Diagram of Configuration)

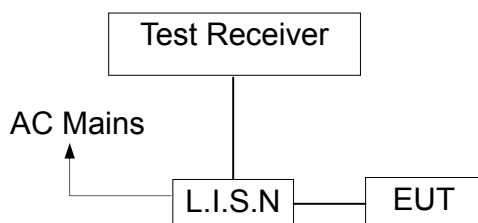

5.3 Measurement Equipment Used:

Conducted Emission Test Site					
EQUIPMENT TYPE	MFR	MODEL NUMBER	SERIAL NUMBER	Last Cal.	Due date
Test Receiver	Rohde & Schwarz	ESCS30	100018	03/16/2015	03/15/2016
L.I.S.N	Rohde & Schwarz	ENV216	100017	03/16/2015	03/15/2016
RF Switching Unit	CDS	RSU-M2	38401	03/16/2015	03/15/2016
Coaxial Cable	CDS	79254	46107086	03/16/2015	03/15/2016

5.4 Conducted Emission Limit

(7) Conducted Emission Frequency(MHz)

0.15-0.5
0.5-5.0
5.0-30.0

Quasi-peak

66-56
56
60

Average

56-46
46
50

Note:

1. The lower limit shall apply at the transition frequencies
2. The limit decreases in line with the logarithm of the frequency in the range of 0.15 to 0.50MHz.

5.5 Measurement Result:

Pass.

All tested the data of the worst mode (GFSK TX 2402MHz) are recorded in the following pages

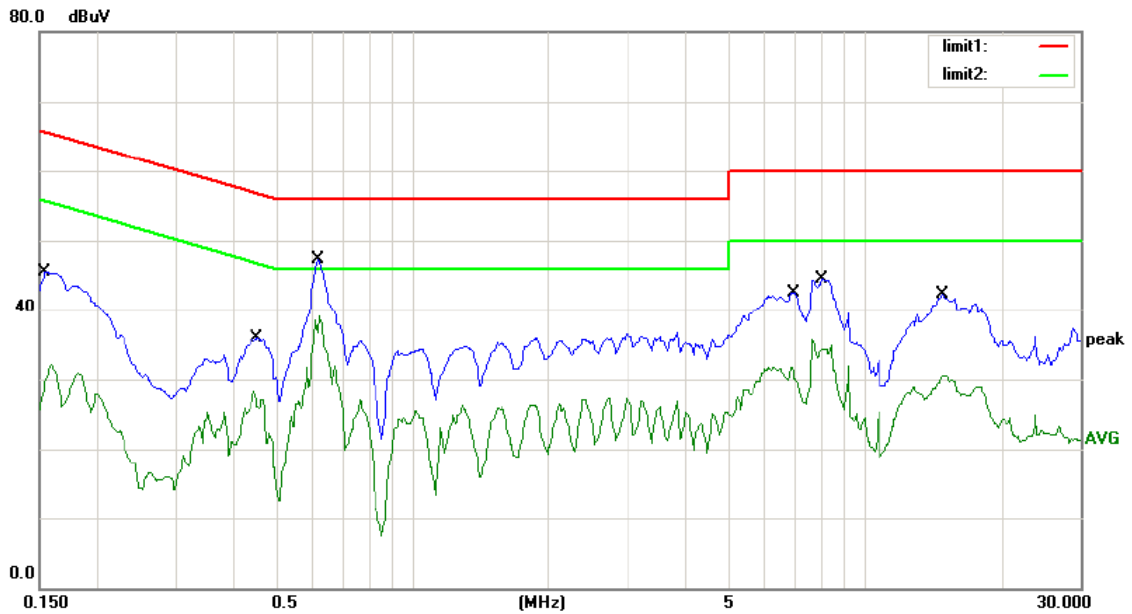

Site site #1 Phase: **L1** Temperature: 24
 Limit: (CE)FCC Part 15B_QP Power: AC 120V/60Hz Humidity: 55 %
 Mode: TX2402
 Note:

No.	Mk.	Freq.	Reading Level	Correct Factor	Measurement	Limit	Over	Detector	Comment
		MHz	dBuV	dB	dBuV	dBuV	dB		
1		0.1545	43.24	0.00	43.24	65.75	-22.51	QP	
2		0.1545	32.14	0.00	32.14	55.75	-23.61	AVG	
3		0.4560	33.14	0.00	33.14	56.77	-23.63	QP	
4		0.4560	28.29	0.00	28.29	46.77	-18.48	AVG	
5		0.6180	45.68	0.00	45.68	56.00	-10.32	QP	
6	*	0.6180	39.02	0.00	39.02	46.00	-6.98	AVG	
7		7.0200	40.51	0.00	40.51	60.00	-19.49	QP	
8		7.0200	31.76	0.00	31.76	50.00	-18.24	AVG	
9		8.0600	42.14	0.00	42.14	60.00	-17.86	QP	
10		8.0600	34.91	0.00	34.91	50.00	-15.09	AVG	
11		14.8750	40.56	0.00	40.56	60.00	-19.44	QP	
12		14.8750	30.55	0.00	30.55	50.00	-19.45	AVG	

*:Maximum data x:Over limit !:over margin Comment: Factor build in receiver.

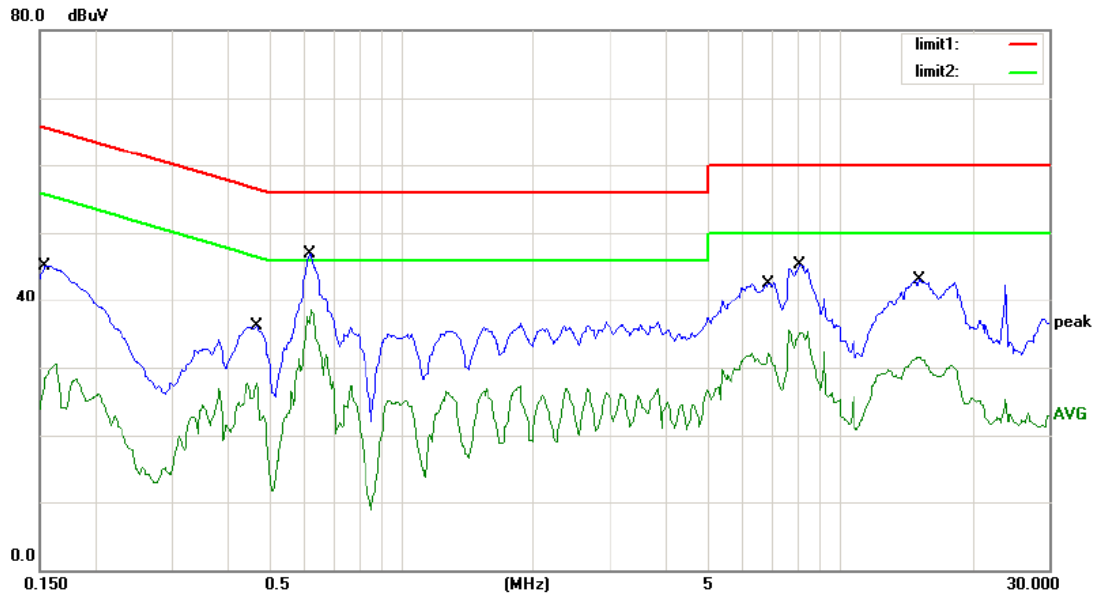

Site site #1 Phase: **N** Temperature: 24
 Limit: (CE)FCC Part 15B_QP Power: AC 120V/60Hz Humidity: 55 %
 Mode: TX2402
 Note:

No.	Mk.	Freq.	Reading Level	Correct Factor	Measurement	Limit	Over	Detector	Comment
		MHz	dBuV	dB	dBuV	dBuV	dB		
1		0.1545	43.51	0.00	43.51	65.75	-22.24	QP	
2		0.1545	30.59	0.00	30.59	55.75	-25.16	AVG	
3		0.4695	34.21	0.00	34.21	56.52	-22.31	QP	
4		0.4695	27.77	0.00	27.77	46.52	-18.75	AVG	
5		0.6180	44.85	0.00	44.85	56.00	-11.15	QP	
6	*	0.6180	38.45	0.00	38.45	46.00	-7.55	AVG	
7		6.9000	40.31	0.00	40.31	60.00	-19.69	QP	
8		6.9000	32.13	0.00	32.13	50.00	-17.87	AVG	
9		8.0700	43.67	0.00	43.67	60.00	-16.33	QP	
10		8.0700	35.44	0.00	35.44	50.00	-14.56	AVG	
11		15.2250	41.74	0.00	41.74	60.00	-18.26	QP	
12		15.2250	31.47	0.00	31.47	50.00	-18.53	AVG	

*:Maximum data x:Over limit !:over margin Comment: Factor build in receiver.

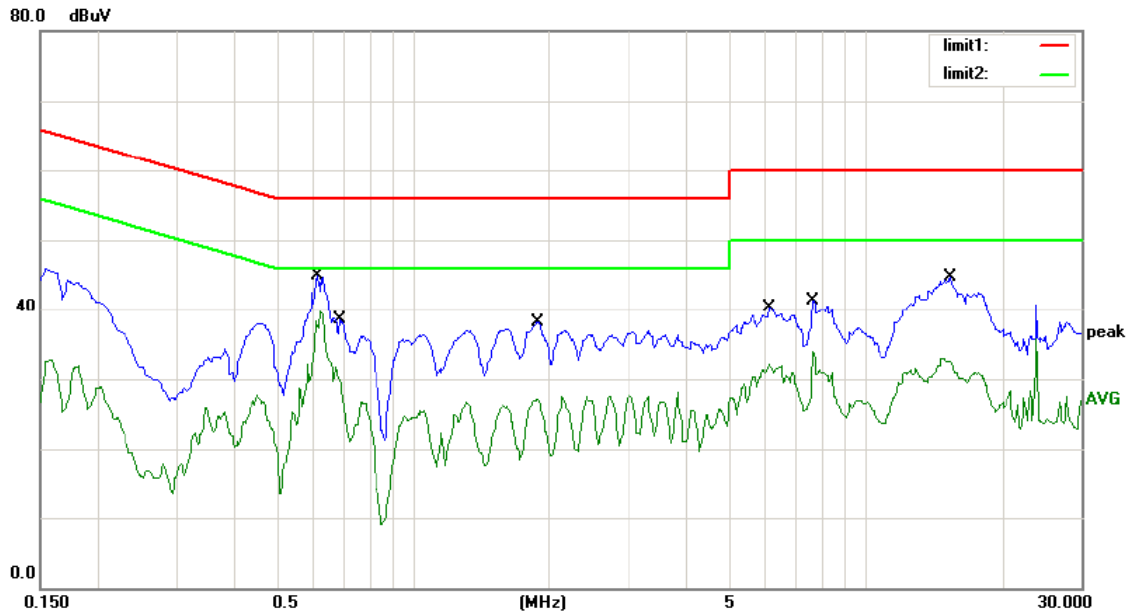

Site site #1 Phase: **L1** Temperature: 24
 Limit: (CE)FCC PART 15_QP Power: AC 240V/50Hz Humidity: 55 %
 Mode: TX2402
 Note:

No.	Mk.	Freq.	Reading Level	Correct Factor	Measurement	Limit	Over	Detector	Comment
		MHz	dBuV	dB	dBuV	dBuV	dB		
1		0.6140	44.89	0.00	44.89	56.00	-11.11	QP	
2	*	0.6140	37.75	0.00	37.75	46.00	-8.25	AVG	
3		0.6863	38.45	0.00	38.45	56.00	-17.55	QP	
4		0.6863	29.85	0.00	29.85	46.00	-16.15	AVG	
5		1.8960	38.18	0.00	38.18	56.00	-17.82	QP	
6		1.8960	27.06	0.00	27.06	46.00	-18.94	AVG	
7		6.1400	40.40	0.00	40.40	60.00	-19.60	QP	
8		6.1400	32.05	0.00	32.05	50.00	-17.95	AVG	
9		7.6800	41.31	0.00	41.31	60.00	-18.69	QP	
10		7.6800	33.92	0.00	33.92	50.00	-16.08	AVG	
11		15.4500	44.66	0.00	44.66	60.00	-15.34	QP	
12		15.4500	31.40	0.00	31.40	50.00	-18.60	AVG	

*:Maximum data x:Over limit !:over margin Comment: Factor build in receiver.

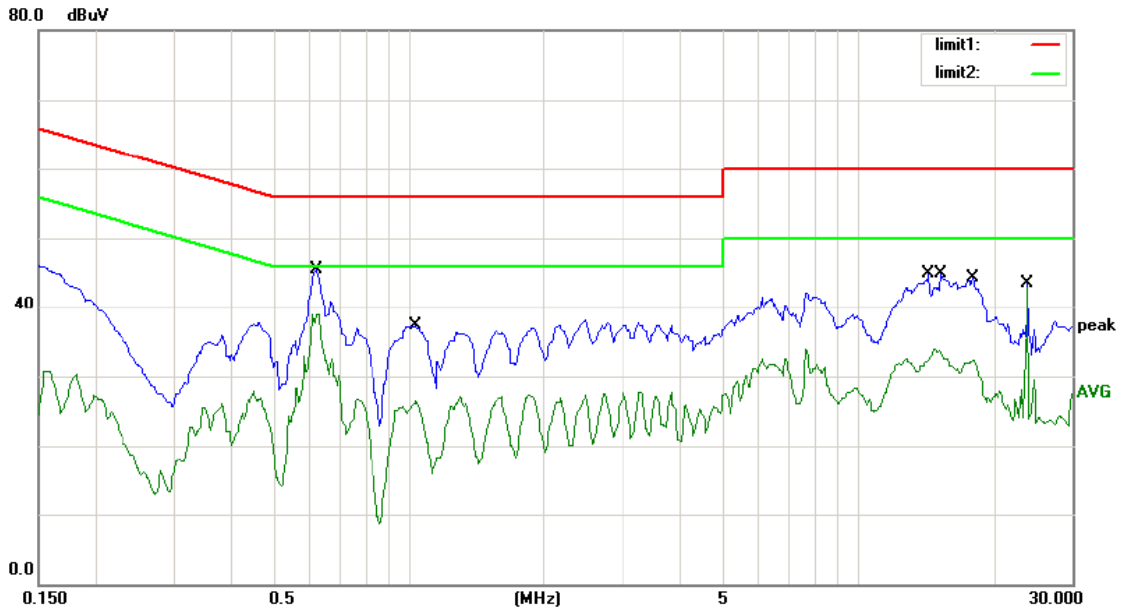

Site site #1 Phase: **N** Temperature: 24
 Limit: (CE)FCC PART 15_QP Power: AC 240V/50Hz Humidity: 55 %
 Mode: TX2402
 Note:

No.	Mk.	Freq. MHz	Reading Level dBuV	Correct Factor dB	Measure- ment dBuV	Limit dBuV	Over dB	Detector	Comment
1		0.6225	45.49	0.00	45.49	56.00	-10.51	QP	
2		0.6225	38.93	0.00	38.93	46.00	-7.07	AVG	
3		1.0410	37.29	0.00	37.29	56.00	-18.71	QP	
4		1.0410	26.50	0.00	26.50	46.00	-19.50	AVG	
5		14.2126	43.90	0.00	43.90	60.00	-16.10	QP	
6		14.2126	32.05	0.00	32.05	50.00	-17.95	AVG	
7		15.2261	44.90	0.00	44.90	60.00	-15.10	QP	
8		15.2261	33.10	0.00	33.10	50.00	-16.90	AVG	
9		17.9500	44.27	0.00	44.27	60.00	-15.73	QP	
10		17.9500	32.32	0.00	32.32	50.00	-17.68	AVG	
11		23.9250	43.52	0.00	43.52	60.00	-16.48	QP	
12	*	23.9250	42.98	0.00	42.98	50.00	-7.02	AVG	

*:Maximum data x:Over limit !:over margin Comment: Factor build in receiver.

4.6 Conducted Measurement Photos:



6. Radiated Emission Test

5.1 Measurement Procedure

- 1 Below 1000MHz, The EUT was placed on a turn table which is 0.1m above ground plane. And above 1000MHz, The EUT was placed on a styrofoam table which is 0.1m above ground plane.
2. Maximum procedure was performed on the six highest emissions to ensure EUT compliance.
3. And also, each emission was to be maximized by changing the polarization of receiving antenna both horizontal and vertical.
4. Repeat above procedures until all frequency measured were complete.

When spectrum scanned from 30MHz to 1GHz setting resolution bandwidth 120KHz and video bandwidth 300KHz:

EMI Test Receiver	Setting
Attenuation	Auto
RB	120KHz
VB	300KHz
Detector	QP
Trace	Max hold

When spectrum scanned above 1GHz setting resolution bandwidth 1MHz, video bandwidth 3MHz:

EMI Test Receiver	Setting
Attenuation	Auto
RB	1MHz
VB	3MHz
Detector	Peak
Trace	Max hold

When spectrum scanned above 1GHz setting resolution bandwidth 1MHz, video bandwidth 10Hz:

EMI Test Receiver	Setting
Attenuation	Auto
RB	1MHz
VB	10Hz
Detector	Peak
Trace	Max hold

For Average Measurement:

VBW=10Hz, when duty cycle is no less than 98 percent.

$VBW \geq 1/T$, when duty cycle is less than 98 percent where T is the minimum transmission duration over which the transmitter is on and is transmitting at its maximum power control level for the tested mode of operation.

Band	Duty Cycle(%)	T(μ s)	1/T(KHz)	Average Correction Factor	VBW Setting
2402-2480	100	-	-	0	10Hz

5.2 Test SET-UP (Block Diagram of Configuration)

(A) Radiated Emission Test Set-Up, Frequency Below 30MHz

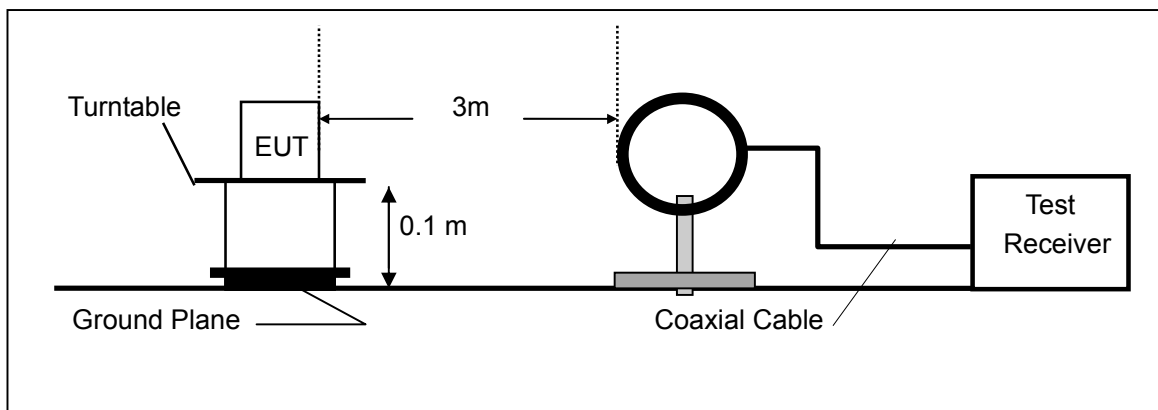

(B) Radiated Emission Test Set-Up, Frequency Below 1000MHz

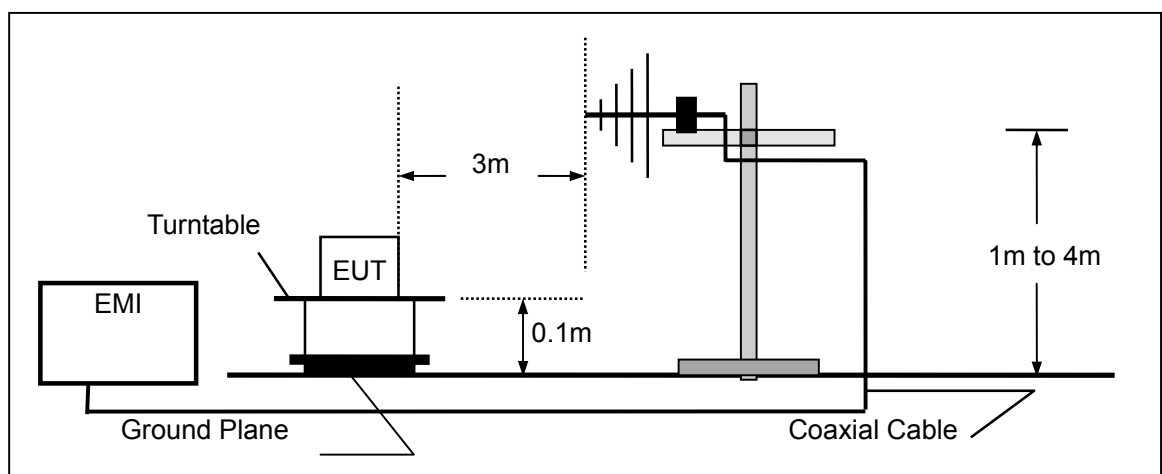

(C) Radiated Emission Test Set-Up, Frequency above 1000MHz

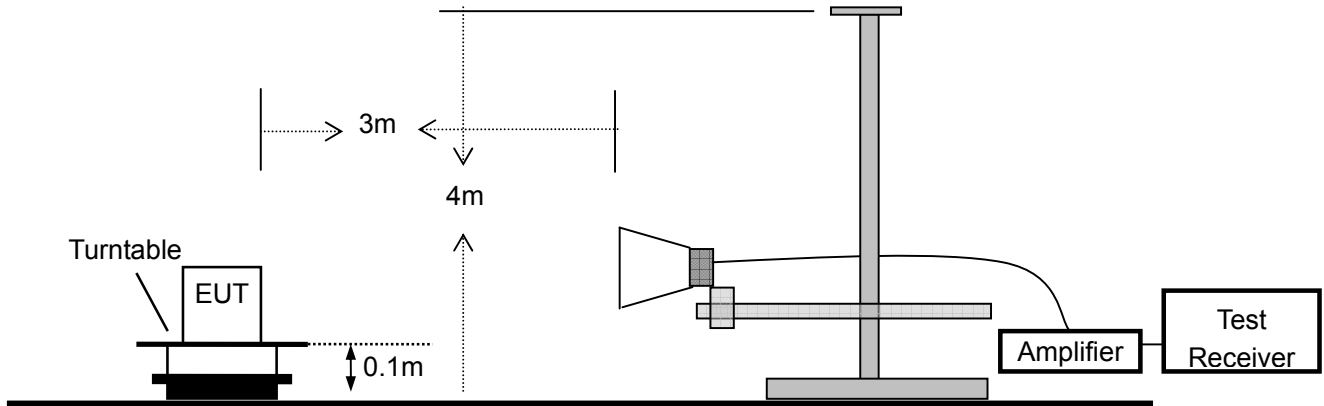

5.3 Measurement Equipment Used:

Item	Equipment	Manufacturer	Model No.	Serial No.	Last Cal.	Cal. Interval
1.	Test Receiver	Rohde & Schwarz	ESCI	1166.5950.03	03/16/2015	1 Year
2.	Bilog Antenna	Schwarzbeck	VULB9163	000141	03/16/2015	1 Year
3.	Power Amplifier	CDS	RSU-M352	818	03/16/2015	1 Year
4.	Power Amplifier	HP	8447F	OPT H64	03/16/2015	1 Year
5.	Color Monitor	SUNSP0	SP-140A	N/A	03/16/2015	1 Year
6.	Single Line Filter	JIANLI	XL-3	N/A	03/16/2015	1 Year
7.	Single Phase Power Line Filter	JIANLI	DL-2X100B	N/A	03/16/2015	1 Year
8.	3 Phase Power Line Filter	JIANLI	DL-4X100B	N/A	03/16/2015	1 Year
9.	DC Power Filter	JIANLI	DL-2X50B	N/A	03/16/2015	1 Year
10.	Cable	Schwarzbeck	PLF-100	549489	03/16/2015	1 Year
11.	Cable	Rosenberger	CIL02	A0783566	03/16/2015	1 Year
12.	Cable	Rosenberger	RG 233/U	525178	03/16/2015	1 Year
13.	Signal Analyzer	Rohde & Schwarz	FSV30	103040	12/29/2014	1 Year
14.	Horn Antenna	Schwarzbeck	BBHA9120D	9120D-1272	12/29/2014	1 Year
15.	Power Amplifier	LUNAR EM	LNA1G18-40	J10100000081	12/29/2014	1 Year
16.	Cable	H+S	CBL-26	N/A	12/29/2014	1 Year
17.	Cable	H+S	CBL-26	N/A	12/29/2014	1 Year
18.	Cable	H+S	CBL-26	N/A	12/29/2014	1 Year

5.4 Radiated emission limit

The emissions from an intentional radiator shall not exceed the field strength levels specified in the following table 15.209(a):

Frequencies (MHz)	Field Strength (microrvolts/meter)	Measurement Distance (meters)
0.009~0.490	2400/F(KHz)	300
0.490~1.705	24000/F(KHz)	30
1.705~30.0	30	30
30~88	100	3
88~216	150	3
216~960	200	3
Above 960	500	3

15.205 Restricted bands of operation

MHz	MHz	MHz	GHz
0.090 - 0.110	16.42 - 16.423	399.9 - 410	4.5 - 5.15
¹ 0.495 - 0.505	16.69475 - 16.69525	608 - 614	5.35 - 5.46
2.1735 - 2.1905	16.80425 - 16.80475	960 - 1240	7.25 - 7.75
4.125 - 4.128	25.5 - 25.67	1300 - 1427	8.025 - 8.5
4.17725 - 4.17775	37.5 - 38.25	1435 - 1626.5	9.0 - 9.2
4.20725 - 4.20775	73 - 74.6	1645.5 - 1646.5	9.3 - 9.5
6.215 - 6.218	74.8 - 75.2	1660 - 1710	10.6 - 12.7
6.26775 - 6.26825	108 - 121.94	1718.8 - 1722.2	13.25 - 13.4
6.31175 - 6.31225	123 - 138	2200 - 2300	14.47 - 14.5
8.291 - 8.294	149.9 - 150.05	2310 - 2390	15.35 - 16.2
8.362 - 8.366	156.52475 - 156.52525	2483.5 - 2500	17.7 - 21.4
8.37625 - 8.38675	156.7 - 156.9	2690 - 2900	22.01 - 23.12
8.41425 - 8.41475	162.0125 - 167.17	3260 - 3267	23.6 - 24.0
12.29 - 12.293	167.72 - 173.2	3332 - 3339	31.2 - 31.8
12.51975 - 12.52025	240 - 285	3345.8 - 3358	36.43 - 36.5
12.57675 - 12.57725	322 - 335.4	3600 - 4400	(²)

- Remark 1. Emission level in dBuV/m=20 log (uV/m)
: 2. Measurement was performed at an antenna to the closed point of EUT distance of meters.
3. Only spurious frequency is permitted to locate within the Restricted Bands specified in provision of § 15.205, and the emissions located in restricted bands also comply with 15.209 limit.

5.5 Measurement Result

Below 30MHz:

Operation Mode:	TX	Test Date :	August 25, 2015
Frequency Range:	9KHz~30MHz	Temperature :	28°C
Test Result:	PASS	Humidity :	65 %
Measured Distance:	3m	Test By:	Andy

Freq. (MHz)	Ant.Pol. H/V	Emission Level (dBuV/m)	Limit 3m (dBuV/m)	Over (dB)
--	--	--	--	--

Note: the amplitude of spurious emission that is attenuated by more than 20dB below the permissible limit has no need to be reported.

Below 1000MHz:

Pass.

All data of the mode (GFSK TX2402) are recorded in the following pages.

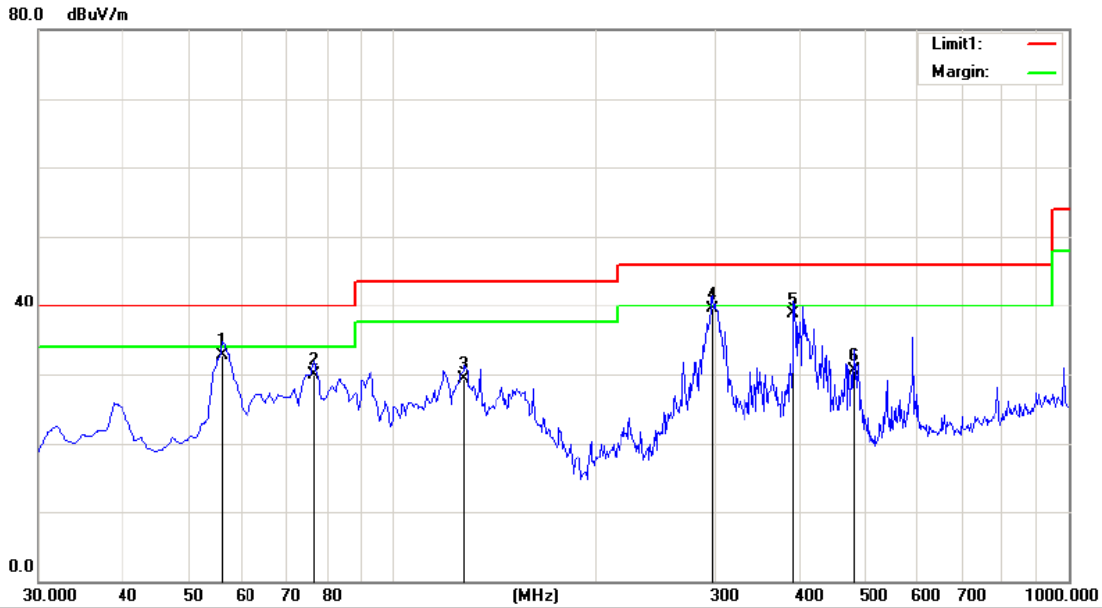

Site site #1 Polarization: **Horizontal** Temperature: 24
 Limit: (RE)FCC PART 15 class B 3m Power: AC 120V/60Hz Humidity: 55 %
 Mode: BT 4.0 TX2402
 Note:

No.	Mk.	Freq.	Reading Level	Correct Factor	Measurement	Limit	Over	Antenna Height	Table Degree
		MHz	dBuV	dB	dBuV/m	dBuV/m	dB	cm	degree
1		56.1900	50.52	-17.84	32.68	40.00	-7.32	QP	0
2		76.5600	52.64	-22.66	29.98	40.00	-10.02	QP	0
3		127.9700	45.56	-16.31	29.25	43.50	-14.25	QP	0
4	*	297.7200	53.91	-14.48	39.43	46.00	-6.57	QP	0
5		392.7800	50.34	-11.58	38.76	46.00	-7.24	QP	0
6		481.0500	41.13	-10.54	30.59	46.00	-15.41	QP	0

*:Maximum data x:Over limit !:over margin

Operator: John

Above 1000MHz

Operation Mode: TX Mode (CH00: 2402MHz) Test Date : August 25, 2015
 Frequency Range: 1-25GHz Temperature : 25 °C
 Test Result: PASS Humidity : 50 %
 Measured Distance: 3m Test By: Andy
 Test Voltage: AC 120V/60Hz

Freq. (MHz)	Ant. Pol. H/V	Emission Level(dBuV/m)		Limit 3m(dBuV/m)		Margin(dB)	
		PK	AV	PK	AV	PK	AV
4804	V	65.39	46.66	74	54	-8.61	-7.34
7206	V	64.25	45.53	74	54	-9.75	-8.47
9608	V	63.56	44.31	74	54	-10.44	-9.69
12010	V	62.78	43.26	74	54	-11.22	-10.74
14412	V	61.13	42.58	74	54	-12.87	-11.42
16814	V	60.32	41.78	74	54	-13.68	-12.22
4804	H	65.2	46.13	74	54	-8.8	-7.87
7206	H	64.15	45.21	74	54	-9.85	-8.79
9608	H	63.25	44.54	74	54	-10.75	-9.46
12010	H	62.45	43.68	74	54	-11.55	-10.32
14412	H	61.68	42.61	74	54	-12.32	-11.39
16814	H	60.56	41.92	74	54	-13.44	-12.08

Other harmonics emissions are lower than 20dB below the allowable limit.

- Note:**
- (1) All Readings are Peak Value and AV.
 - (2) Emission Level= Reading Level+ Probe Factor +Cable Loss.
 - (3) The average measurement was not performed when the peak measured data under the limit of average detection.

Operation Mode: TX Mode (CH20: 2442MHz) Test Date : August 25, 2015
 Frequency Range: 1-25GHz Temperature : 25 °C
 Test Result: PASS Humidity : 50 %
 Measured Distance: 3m Test By: Andy
 Test Voltage: AC 120V/60Hz

Freq. (MHz)	Ant. Pol. H/V	Emission Level(dBuV/m)		Limit 3m(dBuV/m)		Margin(dB)	
		PK	AV	PK	AV	PK	AV
4884	V	65.09	46.88	74	54	-8.91	-7.12
7326	V	64.52	45.65	74	54	-9.48	-8.35
9768	V	63.45	44.52	74	54	-10.55	-9.48
12210	V	62.98	43.62	74	54	-11.02	-10.38
14652	V	61.53	42.76	74	54	-12.47	-11.24
17094	V	60.82	41.69	74	54	-13.18	-12.31
4884	H	66.98	45.29	74	54	-7.02	-8.71
7326	H	65.83	44.61	74	54	-8.17	-9.39
9768	H	64.56	43.58	74	54	-9.44	-10.42
12210	H	63.74	42.62	74	54	-10.26	-11.38
14652	H	62.62	41.89	74	54	-11.38	-12.11
17094	H	61.73	40.71	74	54	-12.27	-13.29

Other harmonics emissions are lower than 20dB below the allowable limit.

- Note:**
- (1) All Readings are Peak Value and AV.
 - (2) Emission Level= Reading Level+ Probe Factor +Cable Loss.
 - (3) The average measurement was not performed when the peak measured data under the limit of average detection.

Operation Mode: TX Mode (CH39: 2480MHz) Test Date : August 25, 2015
 Frequency Range: 1-25GHz Temperature : 25 °C
 Test Result: PASS Humidity : 50 %
 Measured Distance: 3m Test By: Andy
 Test Voltage: AC 120V/60Hz

Freq. (MHz)	Ant. Pol. H/V	Emission Level(dBuV/m)		Limit 3m(dBuV/m)		Margin(dB)	
		PK	AV	PK	AV	PK	AV
4960	V	64.19	45.12	74	54	-9.81	-8.88
7440	V	63.25	44.21	74	54	-10.75	-9.79
9920	V	62.45	43.54	74	54	-11.55	-10.46
12400	V	61.47	42.45	74	54	-12.53	-11.55
14880	V	60.39	41.78	74	54	-13.61	-12.22
17360	V	59.87	40.69	74	54	-14.13	-13.31
4960	H	65.24	45.06	74	54	-8.76	-8.94
7440	H	64.42	44.35	74	54	-9.58	-9.65
9920	H	63.57	43.67	74	54	-10.43	-10.33
12400	H	62.28	42.58	74	54	-11.72	-11.42
14880	H	61.86	41.74	74	54	-12.14	-12.26
17360	H	60.34	40.56	74	54	-13.66	-13.44

Other harmonics emissions are lower than 20dB below the allowable limit.

- Note:**
- (1) All Readings are Peak Value and AV.
 - (2) Emission Level= Reading Level+ Probe Factor +Cable Loss.
 - (3) The average measurement was not performed when the peak measured data under the limit of average detection.

5.6 Radiated Measurement Photos:

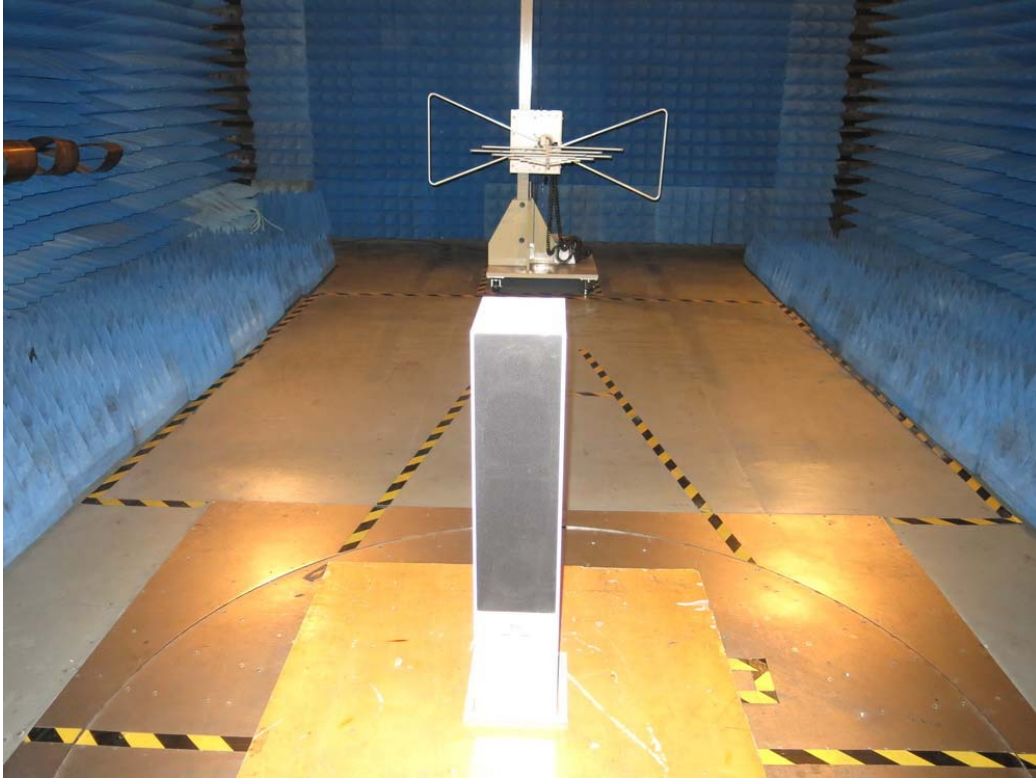

7. 6dB Bandwidth Measurement

6.1 Measurement Procedure

The EUT was operating in Bluetooth mode or could be controlled its channel. Printed out the test result from the spectrum by hard copy function.

6.2 Test SET-UP (Block Diagram of Configuration)

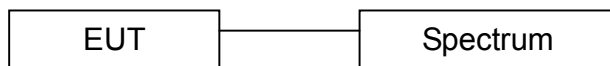

6.3 Measurement Equipment Used:

EQUIPMENT TYPE	MFR	MODEL NUMBER	SERIAL NUMBER	LAST CAL.	CAL DUE.
Spectrum Analyzer	Rohde & Schwarz	FSV30	1321.3008K	03/16/2015	03/15/2016
Coaxial Cable	CDS	79254	46107086	03/16/2015	03/15/2016

6.4 Limit

The minimum 6dB bandwidth shall be at least 500kHz.

6.5 Measurement Results:

Refer to attached data chart.

Spectrum Detector:	PK	Test Date :	August 25, 2015
Test By:	Andy	Temperature :	25 °C
Test Result:	PASS	Humidity :	50 %

Channel number	Channel frequency (MHz)	Measurement level (KHz)	Required Limit (KHz)
00	2402	673	>500
20	2442	671	>500
39	2480	673	>500

Channel 00:

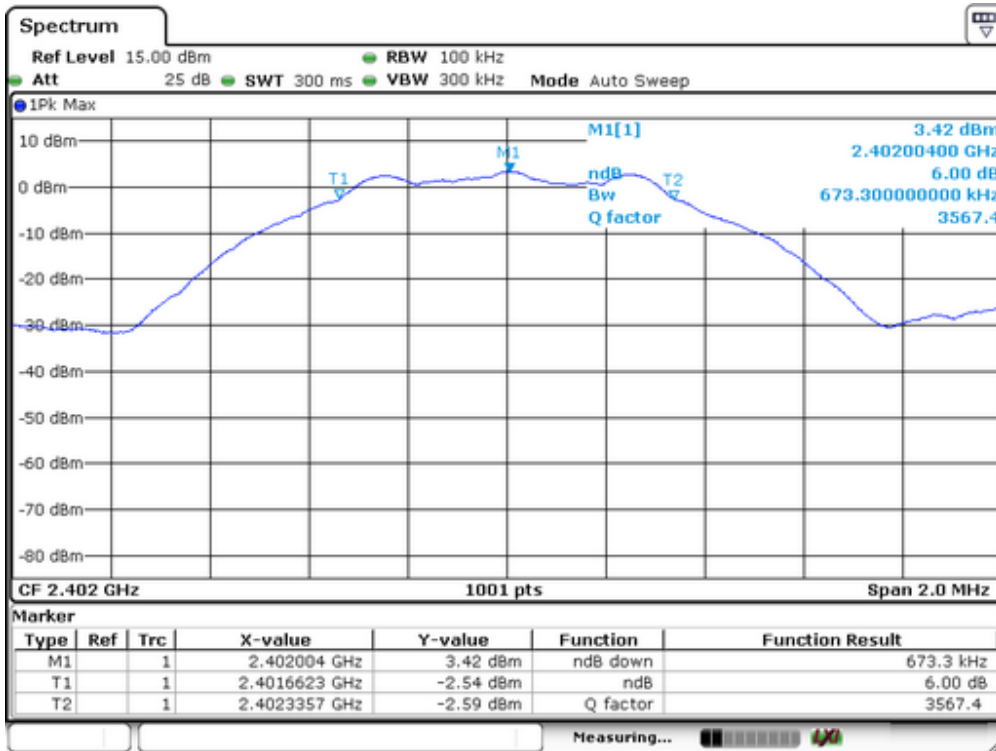

Channel 20:

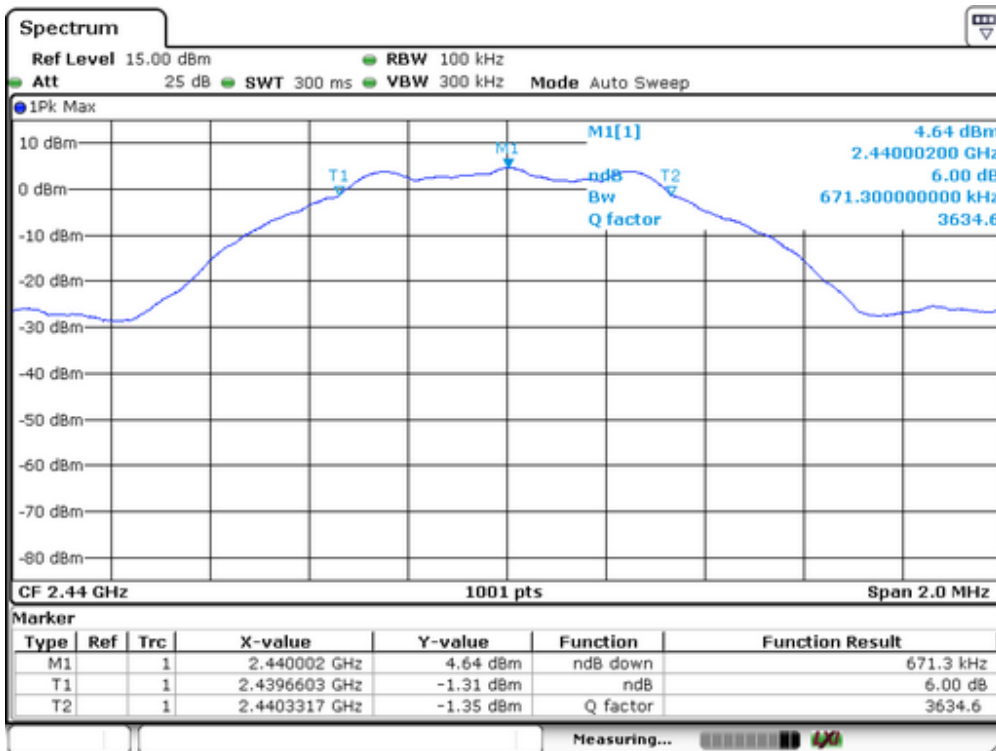

Channel 39:

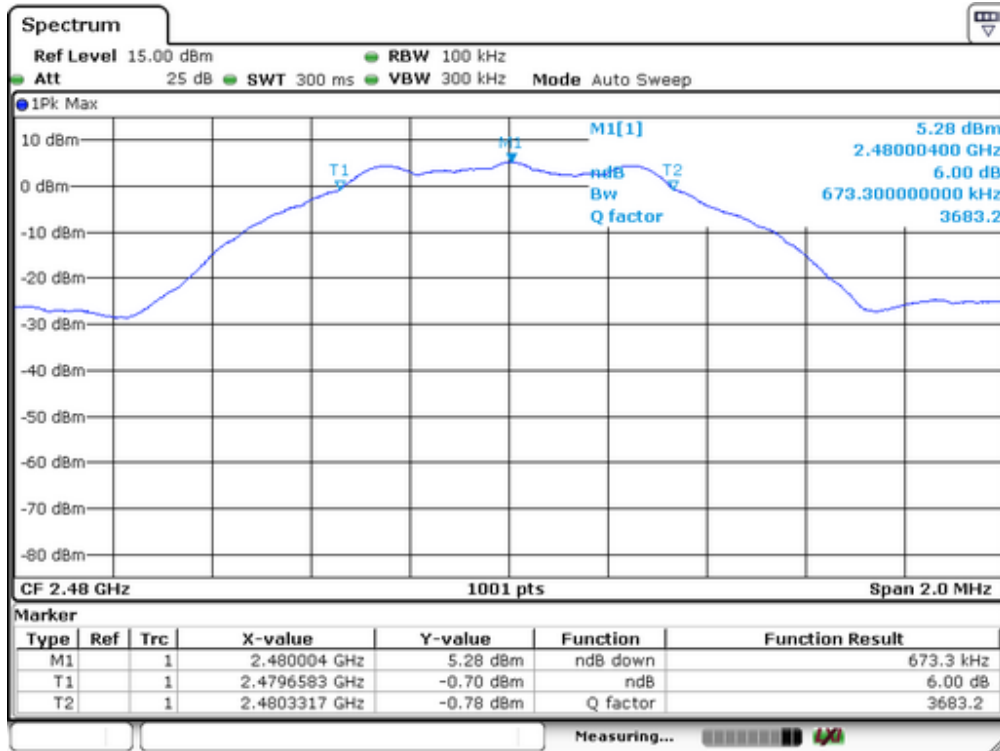

7. MAXIMUM PEAK OUTPUT POWER TEST

7.1 Measurement Procedure

- The Transmitter output (antenna port) was connected to the spectrum Analyzer.
- Turn on the EUT and then record the peak power value.
- Repeat above procedures on all channels needed to be tested.

7.2 Test SET-UP (Block Diagram of Configuration)



7.3 Measurement Equipment Used:

EQUIPMENT TYPE	MFR	MODEL NUMBER	SERIAL NUMBER	LAST CAL.	CAL DUE.
Spectrum Analyzer	Rohde & Schwarz	FSV30	1321.3008K	03/16/2015	03/15/2016
Coaxial Cable	CDS	79254	46107086	03/16/2015	03/15/2016

7.4 Peak Power output limit

The maximum peak power shall be less 1Watt.

7.5 Measurement Results:

Refer to attached data chart.

Spectrum Detector: PK Test Date : August 25, 2015
 Test By: Andy Temperature : 25 °C
 Test Result: PASS Humidity : 50 %

Channel number	Channel Frequency (MHz)	Peak Power output(dBm)	Peak Power output(mW)	Peak Power Limit(W)	Pass/Fail
0	2402	3.69	2.339	1W(30dBm)	PASS
20	2442	4.91	3.097	1W(30dBm)	PASS
39	2480	5.48	3.532	1W(30dBm)	PASS

Channel 00:

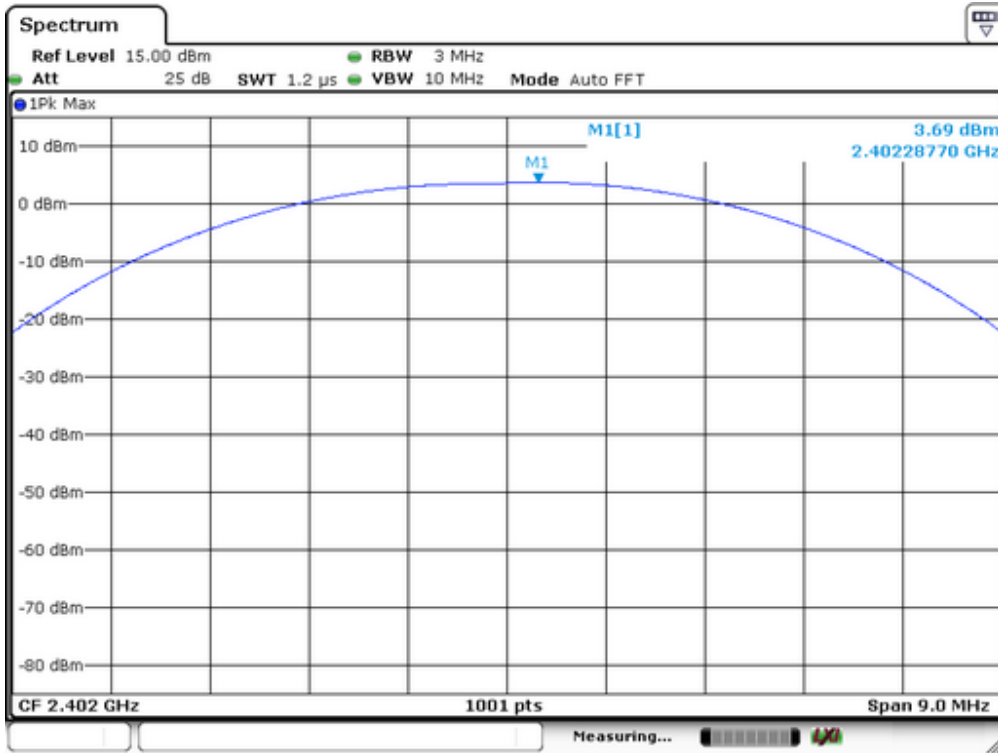

Channel 20:

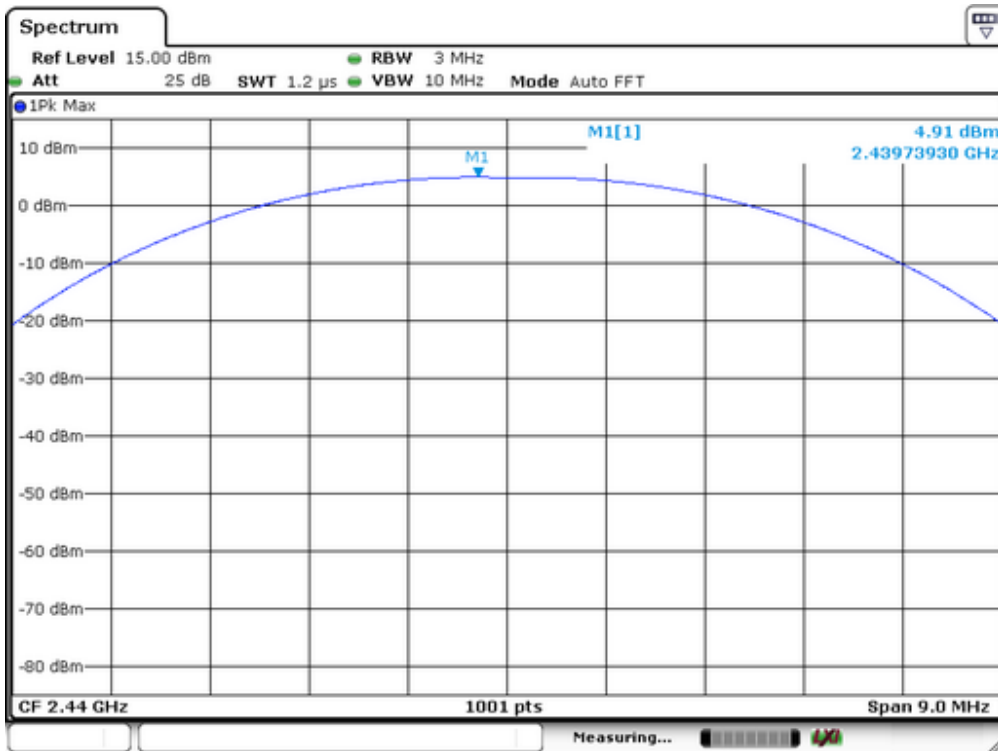

Channel 39:

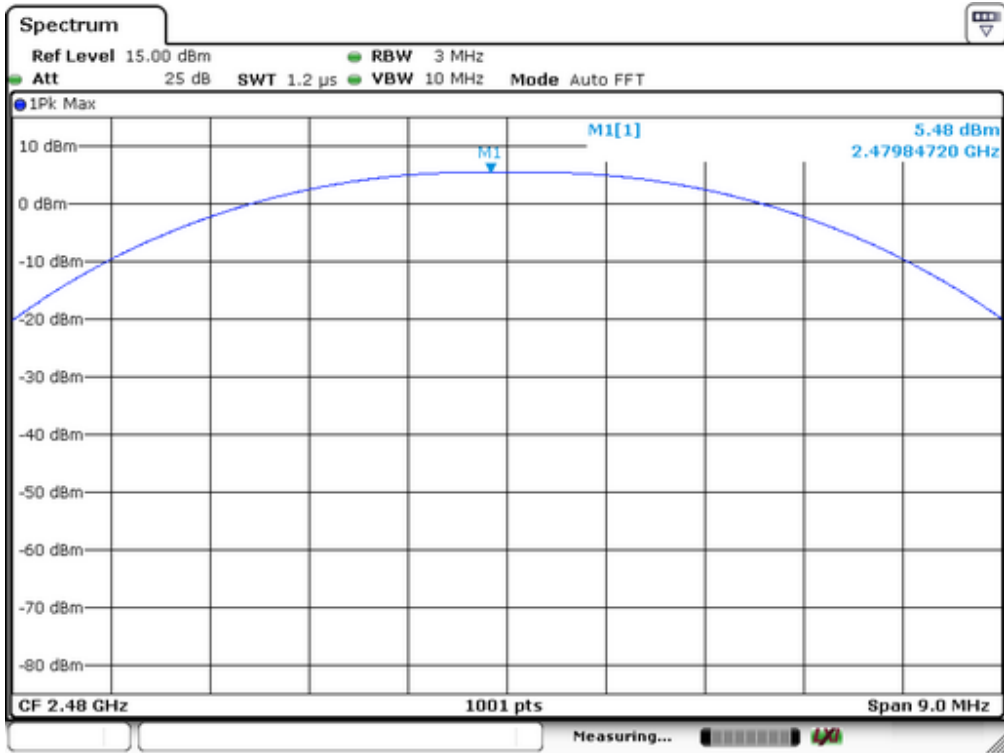

8. Power Spectral Density Measurement

8.1 Measurement Procedure

The EUT was operating in Bluetooth mode or could be controlled its channel. Printed out the test result from the spectrum by hard copy function.

8.2 Test SET-UP (Block Diagram of Configuration)

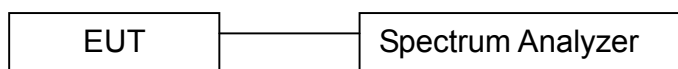

8.3 Measurement Equipment Used:

EQUIPMENT TYPE	MFR	MODEL NUMBER	SERIAL NUMBER	LAST CAL.	CAL DUE.
Spectrum Analyzer	Rohde & Schwarz	FSV30	1321.3008K	03/16/2015	03/15/2016
Coaxial Cable	CDS	79254	46107086	03/16/2015	03/15/2016

8.4 Measurement Procedure

8.4.1 The RF output of EUT was connected to the spectrum analyzer by RF cable and attenuator. The path loss was compensated to the results for each measurement.

8.4.2. Set to the maximum power setting and enable the EUT transmit continuously.

8.4.3. Make the measurement with the spectrum analyzer's resolution bandwidth (RBW) = 3 kHz. Video bandwidth VBW = 10 kHz In order to make an accurate measurement, set the span to 1.5 times DTS Channel Bandwidth. (6dB BW)

8.4.4. Detector = peak, Sweep time = auto couple, Trace mode = max hold, Allow trace to fully stabilize. Use the peak marker function to determine the maximum power level.

8.4.5. Measure and record the results in the test report.

8.4.6. The Measured power density (dBm)/ 100KHz is a reference level and used as 20dBc down limit line for Conducted Band Edges and Conducted Spurious Emission.

8.5 Measurement Results:

The following table is the setting of spectrum analyzer.

Spectrum analyzer	Setting
Attenuation	Auto
Span Frequency	Set the span to 1.5 times the DTS bandwidth.
RB	3KHz
VB	10KHz
Detector	Peak
Trace	Max hold
Sweep Time	Automatic

Refer to attached data chart.

Spectrum Detector:	PK	Test Date :	August 25, 2015
Test By:	Andy	Temperature :	25 °C
Test Result:	PASS	Humidity :	50 %

Channel number	Channel frequency (MHz)	Measurement level (dBm)		Required Limit (dBm/3kHz)	Pass/Fail
		PSD/100kHz	PSD/3kHz		
00	2402	4.69	-12.23	8	PASS
20	2442	4.70	-10.86	8	PASS
39	2480	5.31	-10.32	8	PASS

Note:

1. Measured power density(dBm) has offset with cable loss.
2. The measured power density(dBm)/100KHz is reference level and used as 20dBc down for Conducted Band Edges and Conducted Spurious Emission limit line.

PSD 100kHz Plot:
Channel 00

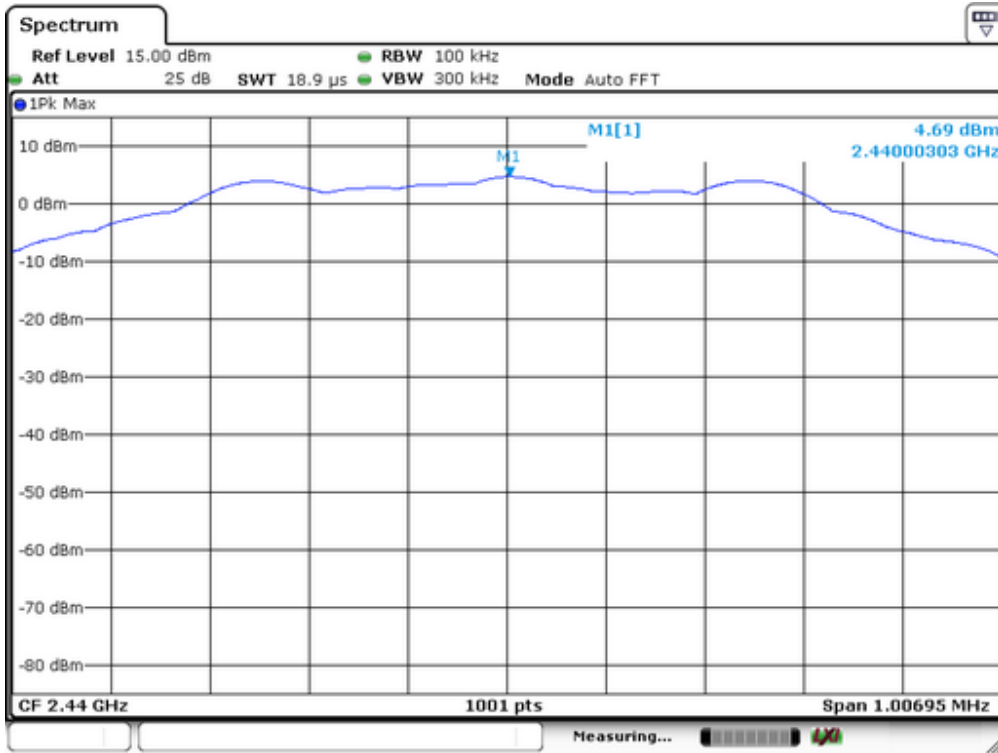

Channel 20

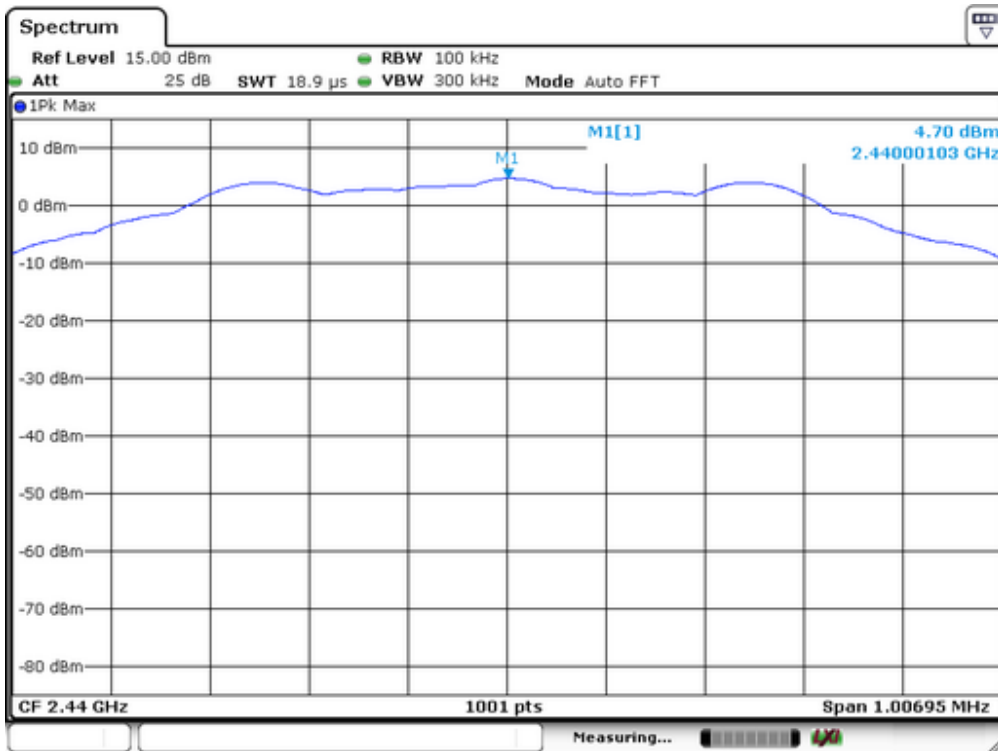

Channel 39

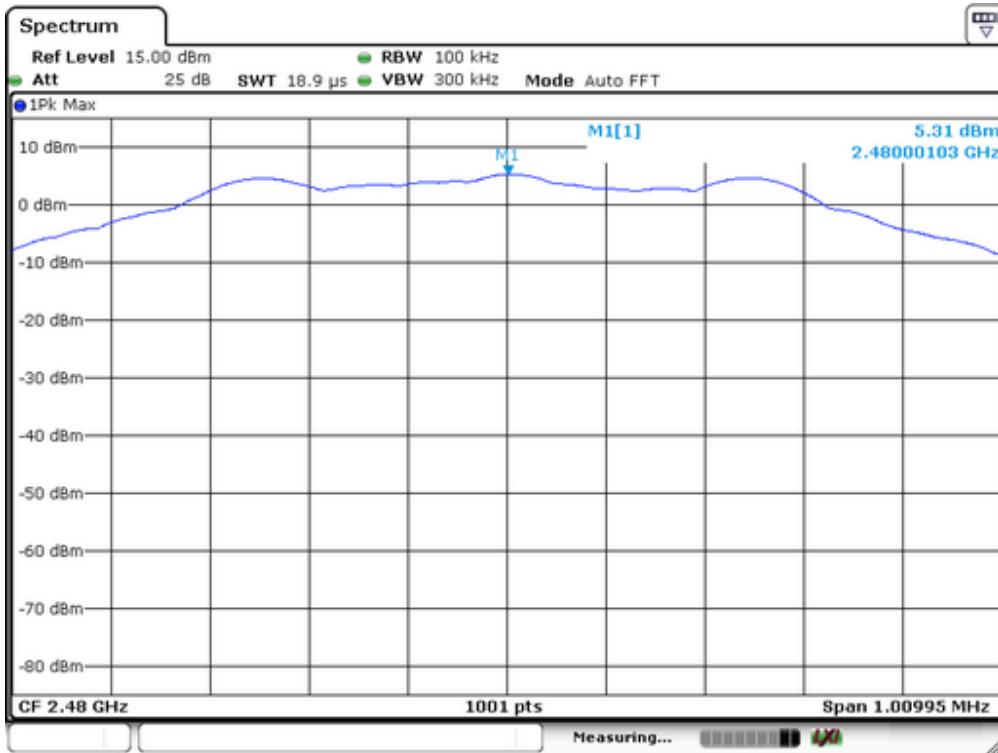

PSD 3KHz Plot:
Channel 00

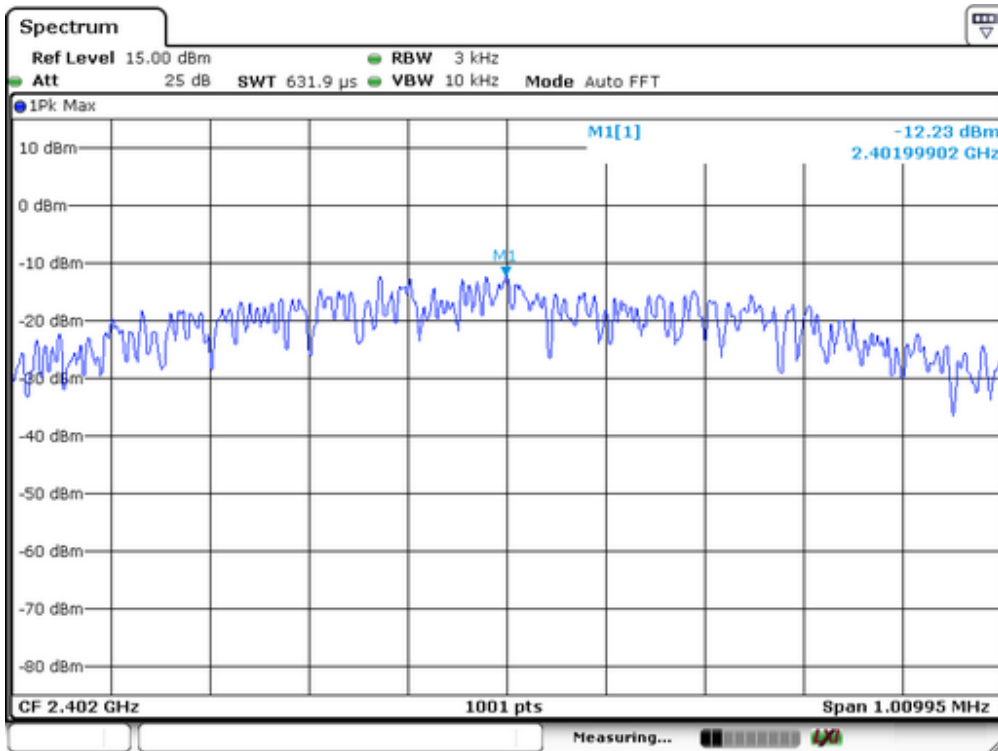

Channel 20

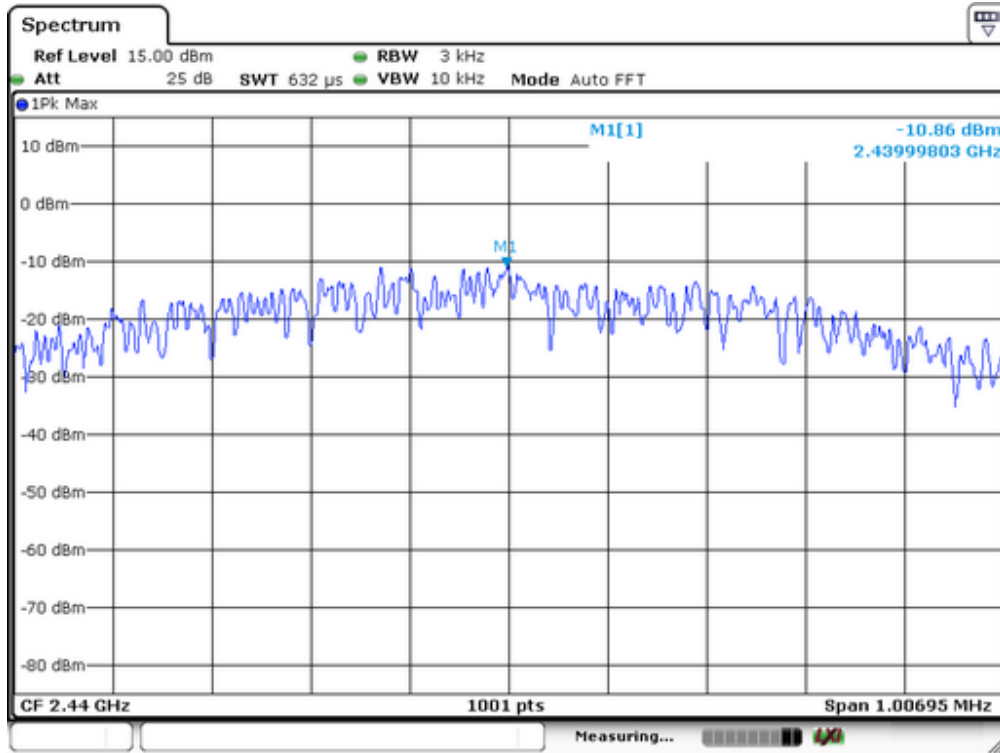

Channel 39

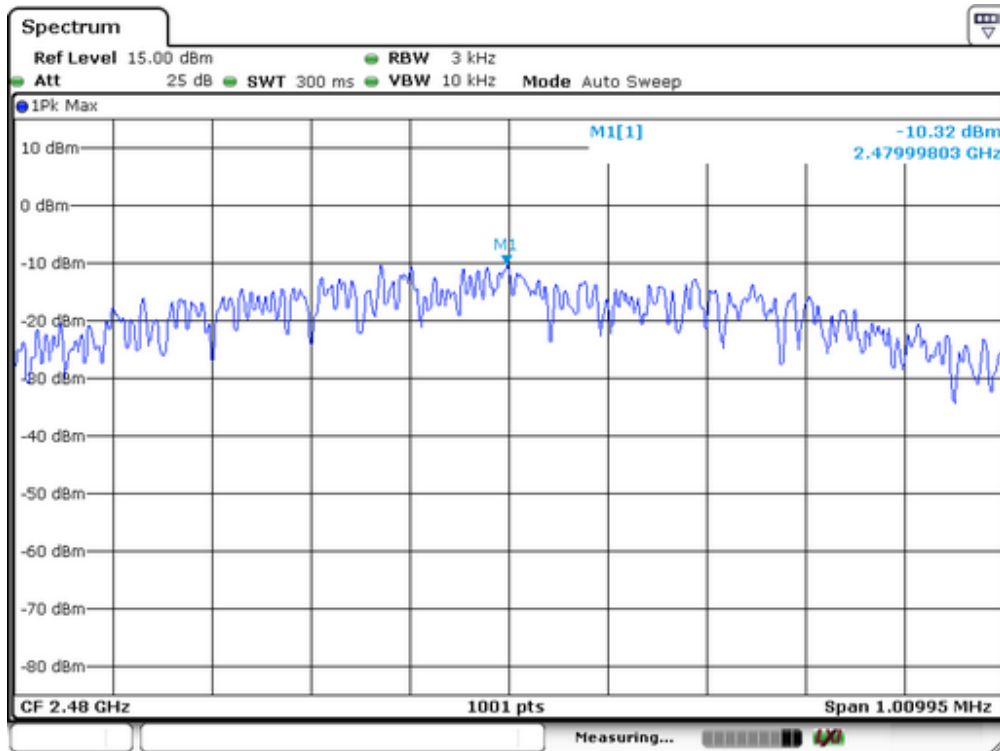

9. Band EDGE test

9.1 Measurement Procedure

For Conducted Test

1. The transmitter output is connected to a spectrum analyzer. The resolution bandwidth is set to 100KHz. The video bandwidth is set to 300KHz.
2. The spectrum from 30MHz to 26 GHz is investigated with the transmitter set to the lowest, middle, and highest channels.
3. Preliminary tests on individual chains, and on all chains with a combiner, were performed. The worst-case configuration was with a combiner, therefore final test were performed with all chains feeding a combiner.

For Radiated emission Test

1. The EUT was Operating in hopping mode or could be controlled its channel. Printed out test result from the spectrum by hard copy function.
2. The EUT was placed on a turn table which is 0.1m above ground plane.
3. Maximum procedure was performed on the six highest emissions to ensure EUT compliance.
4. And also, each emission was to be maximized by changing the polarization of receiving antenna both horizontal and vertical.
5. Repeat above procedures until all frequency measured were complete.

9.2 Test SET-UP (Block Diagram of Configuration)

For Conducted Test

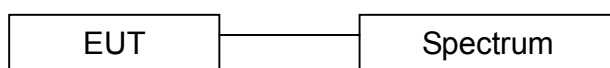

For Radiated emission Test

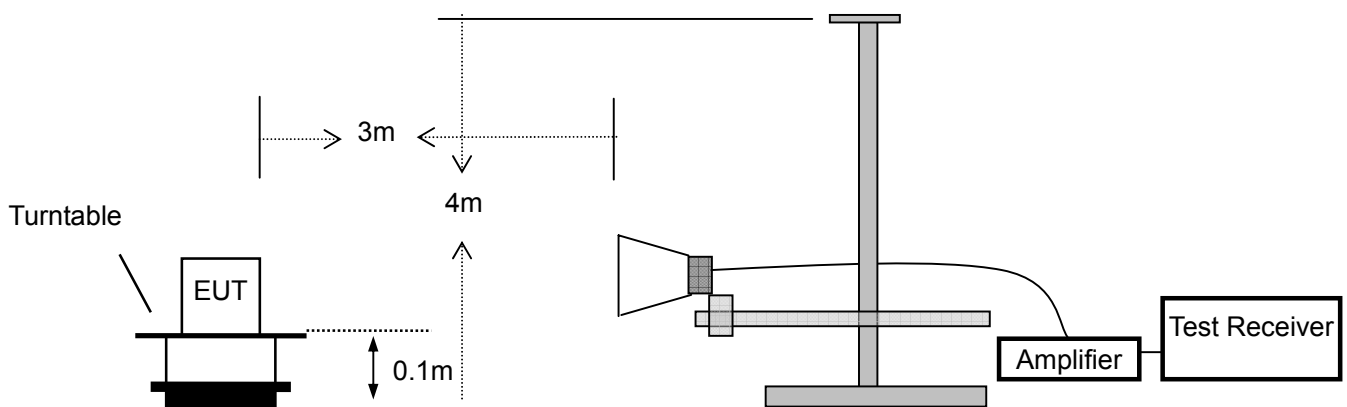

9.3 Measurement Equipment Used:

For Conducted Test

EQUIPMENT TYPE	MFR	MODEL NUMBER	SERIAL NUMBER	LAST CAL.	CAL DUE.
Spectrum Analyzer	Rohde & Schwarz	FSV30	1321.3008K	03/16/2015	03/15/2016
Coaxial Cable	CDS	79254	46107086	03/16/2015	03/15/2016

For Radiated emission Test

Item	Equipment	Manufacturer	Model No.	Serial No.	Last Cal.	Cal. Interval
1	Signal Analyzer	Rohde & Schwarz	FSV30	103040	12/29/2014	1 Year
2	Horn Antenna	Schwarzbeck	BBHA9120D	9120D-1272	12/29/2014	1 Year
3	Power Amplifier	LUNAR EM	LNA1G18-40	J10100000081	12/29/2014	1 Year
4	Cable	H+S	CBL-26	N/A	12/29/2014	1 Year
5	Cable	H+S	CBL-26	N/A	12/29/2014	1 Year
6	Cable	H+S	CBL-26	N/A	12/29/2014	1 Year

9.4 Measurement Results:

Refer to attached data chart.

Spectrum Detector: PK Test Date : August 25, 2015
 Test By: Andy Temperature : 25 °C
 Test Result: PASS Humidity : 50 %

1. Conducted Test

Frequency (MHz)	Peak Power Output(dBm)	Emission read Value(dBm)	Result of Band edge(dBc)	Band edge Limit(dBc)
2399.99	3.45	-48.07	51.52	>20dBc
2484.00	5.42	-59.44	64.86	>20dBc

2. Radiated emission Test

Frequency (MHz)	Antenna polarization (H/V)	Emission (dBuV/m)		Band edge Limit (dBuV/m)		Margin (dB)	
		PK	AV	PK	AV	PK	AV
2397.05	H	64.05	45.05	74	54	-9.95	-8.95
2399.35	V	60.27	41.27	74	54	-13.73	-12.73
2484.19	H	65.17	46.37	74	54	-8.83	-7.63
2485.06	V	59.35	40.27	74	54	-14.65	-13.73

10 Antenna Application

10.1 Antenna requirement

The EUT'S antenna is met the requirement of FCC part 15C section 15.203 and 15.247.

FCC part 15C section 15.247 requirements:

Systems operating in the 2402-2480MHz band that are used exclusively for fixed, point-to-point operations may employ transmitting antennas with directional gain greater than 6dBi provided the maximum peak output power of the intentional radiator is reduced by 1dB for every 3dB that the directional gain of the antenna exceeds 6dBi.

10.2 Result

The EUT's antenna, permanent attached antenna, used a PCB antenna and integrated on PCB, The antenna's gain is 0 dBi and meets the requirement.

APPENDIX I (PHOTOS OF EUT)



