

FCC 47 CFR PART 15 SUBPART E

CERTIFICATION TEST REPORT

For

OTT BOX

MODEL No.: WH220-IOT, Air, Iskon, Hilton,
Moon, Maia, Vega, Hyperion, Sirius

FCC ID: 2AF9RWH220-IOT

Trade Mark: N/A

REPORT NO.: ES180511033W05

ISSUE DATE: July 6, 2018

Prepared for

Wetek Electronics Limited.

Level 10, Central building, 1-3 Pedder Street, Central, Hong Kong

Prepared by

EMTEK(SHENZHEN) CO., LTD.

Bldg 69, Majialong Industry Zone, Nanshan District,
Shenzhen, Guangdong, China

TEL: 86-755-26954280

FAX: 86-755-26954282

1 TEST RESULT CERTIFICATION

Applicant : Wetek Electronics Limited.
 Address : Level 10, Central building, 1-3 Pedder Street, Central, Hong Kong
 Manufacturer : Wetek Electronics Limited.
 Address : Level 10, Central building, 1-3 Pedder Street, Central, Hong Kong
 EUT : OTT BOX
 Model Name : WH220-IOT, Air, Iskon, Hilton, Moon, Maia, Vega, Hyperion, Sirius (They have the same are identical in circuitry and electrical, mechanical and physical construction; only the export market is different, so the model is different, but the function is the same. We choose WH220-IOT as the final test prototype.)
 Trademark : N/A

Measurement Procedure Used:

APPLICABLE STANDARDS	
STANDARD	TEST RESULT
FCC 47 CFR Part 2, Subpart J FCC 47 CFR Part 15, Subpart E	PASS

The above equipment was tested by EMTEK (SHENZHEN) CO., LTD. The test data, data evaluation, test procedures, and equipment configurations shown in this report were made in accordance with the procedures given in ANSI C63.10 (2013) and the energy emitted by the sample EUT tested as described in this report is in compliance with the requirements of FCC Rules Part 2 and Part 15.407

The test results of this report relate only to the tested sample identified in this report.

Date of Test : June 01, 2018 to June 29, 2018

Prepared by: 
Sewen Guo /Editor

Reviewer: 
Joe Xia /Supervisor

Approve & Authorized Signer : 
Lisa Wang/Manager



TABLE OF CONTENTS

1 TEST RESULT CERTIFICATION 2

2 EUT TECHNICAL DESCRIPTION 4

3 SUMMARY OF TEST RESULT 6

4 TEST METHODOLOGY 7

4.1 GENERAL DESCRIPTION OF APPLIED STANDARDS 7

4.2 MEASUREMENT EQUIPMENT USED 7

4.3 DESCRIPTION OF TEST MODES 8

5 FACILITIES AND ACCREDITATIONS 12

5.1 FACILITIES..... 12

5.2 LABORATORY ACCREDITATIONS AND LISTINGS 12

6 TEST SYSTEM UNCERTAINTY 13

7 SETUP OF EQUIPMENT UNDER TEST 14

7.1 RADIO FREQUENCY TEST SETUP 14

7.2 RADIO FREQUENCY TEST SETUP 14

7.3 CONDUCTED EMISSION TEST SETUP 16

7.4 BLOCK DIAGRAM CONFIGURATION OF TEST SYSTEM..... 17

7.5 SUPPORT EQUIPMENT..... 17

8 TEST REQUIREMENTS 18

8.1 BANDWIDTH MEASUREMENT 18

8.2 MAXIMUM CONDUCTED OUTPUT POWER..... 53

8.3 MAXIMUM PEAK POWER DENSITY 66

8.4 FREQUENCY STABILITY 138

8.5 UNDESIRABLE RADIATED SPURIOUS EMISSION..... 148

8.6 POWER LINE CONDUCTED EMISSIONS..... 173

8.7 ANTENNA APPLICATION 176

2 EUT TECHNICAL DESCRIPTION

Characteristics	Description
Product	OTT BOX
Model Number	WH220-IOT, Air, Iskon, Hilton, Moon, Maia, Vega, Hyperion, Sirius (They have the same are identical in circuitry and electrical, mechanical and physical construction; only the export market is different, so the model is different, but the function is the same. We choose WH220-IOT as the final test prototype.)
Wifi Type	<input checked="" type="checkbox"/> UNII-1: 5150MHz-5250MHz Band <input checked="" type="checkbox"/> UNII-2A: with 5250MHz-5350MHz Band <input checked="" type="checkbox"/> UNII-2C: with 5470MHz-5725MHz Band <input checked="" type="checkbox"/> UNII-3 with 5725MHz-5850MHz Band
WLAN Supported	<input checked="" type="checkbox"/> 802.11a <input checked="" type="checkbox"/> 802.11n(20MHz channel bandwidth) <input checked="" type="checkbox"/> 802.11n(40MHz channel bandwidth) <input checked="" type="checkbox"/> 802.11ac(20MHz channel bandwidth) <input checked="" type="checkbox"/> 802.11ac(40MHz channel bandwidth) <input checked="" type="checkbox"/> 802.11ac(80MHz channel bandwidth)
Data Rate	802.11a:54/48/36/24/18/12/9/6Mbps 802.11n:up to 600 Mbps 802.11ac:up to 1.733Gbps
Modulation	<input checked="" type="checkbox"/> OFDM with BPSK/QPSK/16QAM/64QAM for 802.11a/n; <input checked="" type="checkbox"/> OFDM with BPSK/QPSK/16QAM/64QAM/256QAM for 802.11ac;
Frequency Range	<input checked="" type="checkbox"/> UNII-1: 5150MHz-5250MHz Band
	<input checked="" type="checkbox"/> 5180-5240MHz for 802.11a; <input checked="" type="checkbox"/> 5180-5240MHz for 802.11n(HT20); <input checked="" type="checkbox"/> 5180-5240MHz for 802.11ac(VHT20); <input checked="" type="checkbox"/> 5190-5230MHz for 802.11n(HT40); <input checked="" type="checkbox"/> 5190-5230MHz for 802.11ac(VHT40); <input checked="" type="checkbox"/> 5210MHz for 802.11ac(VHT80);
	<input checked="" type="checkbox"/> UNII-2A: with 5250MHz-5350MHz Band
	<input checked="" type="checkbox"/> 5260-5320MHz for 802.11a; <input checked="" type="checkbox"/> 5260-5320MHz for 802.11n(HT20); <input checked="" type="checkbox"/> 5260-5320MHz for 802.11ac(VHT20); <input checked="" type="checkbox"/> 5270-5310MHz for 802.11n(HT40); <input checked="" type="checkbox"/> 5270-5310MHz for 802.11ac(VHT40); <input checked="" type="checkbox"/> 5290MHz for 802.11ac(VHT80);
	<input checked="" type="checkbox"/> UNII-2C: with 5470MHz-5725MHz Band
	<input checked="" type="checkbox"/> 5500-5700MHz for 802.11a; <input checked="" type="checkbox"/> 5500-5700MHz for 802.11n(HT20); <input checked="" type="checkbox"/> 5500-5700MHz for 802.11ac(VHT20); <input checked="" type="checkbox"/> 5510-5670MHz for 802.11n(HT40); <input checked="" type="checkbox"/> 5510-5670MHz for 802.11ac(VHT40); <input checked="" type="checkbox"/> 5530-5610MHz for 802.11ac(VHT80)
	<input checked="" type="checkbox"/> UNII-3 with 5725MHz-5850MHz Band
<input checked="" type="checkbox"/> 5745-5825MHz for 802.11a; <input checked="" type="checkbox"/> 5745-5825MHz for 802.11n(HT20); <input checked="" type="checkbox"/> 5745-5825MHz for 802.11ac(VHT20); <input checked="" type="checkbox"/> 5755-5795MHz for 802.11n(HT40); <input checked="" type="checkbox"/> 5755-5795MHz for 802.11ac(VHT40); <input checked="" type="checkbox"/> 5775MHz for 802.11ac(VHT80);	
TCP Function	<input type="checkbox"/> Applicable <input checked="" type="checkbox"/> Not Applicable
Antenna Port	<input checked="" type="checkbox"/> Antenna port A <input checked="" type="checkbox"/> Antenna port B
Antenna Type	Internal Antenna
Antenna Gain	2 dBi

Transmit Power	Output Power (Max.) for UNII-1 (1TX)	802.11a: 15.64dBm 802.11n(HT 20 MHz): 15.94dBm 802.11n(HT 40 MHz): 15.89dBm 802.11ac (VHT 20 MHz): 15.44dBm 802.11ac (VHT 40 MHz): 15.76dBm 802.11ac (VHT 80 MHz): 15.74dBm
	Output Power (Max.) for UNII-2A (1TX)	802.11a: 15.91dBm 802.11n(HT 20 MHz): 15.79dBm 802.11n(HT 40 MHz): 15.89dBm 802.11ac (VHT 20 MHz): 15.96dBm 802.11ac (VHT 40 MHz): 15.54dBm 802.11ac (VHT 80 MHz): 15.33dBm
	Output Power (Max.) for UNII-2C (1TX)	802.11a: 15.95dBm 802.11n(HT 20 MHz): 15.78dBm 802.11n(HT 40 MHz): 15.85dBm 802.11ac (VHT 20 MHz): 15.85dBm 802.11ac (VHT 40 MHz): 15.92dBm 802.11ac (VHT 80 MHz): 15.62dBm
	Output Power (Max.) for UNII-3 (1TX)	802.11a: 15.69dBm 802.11n(HT 20 MHz): 15.91dBm 802.11n(HT 40 MHz): 15.93dBm 802.11ac (VHT 20 MHz): 15.52dBm 802.11ac (VHT 40 MHz): 15.72dBm 802.11ac (VHT 80 MHz): 15.44dBm
	Output Power (Max.) for UNII-1 (2TX)	802.11n(HT 20 MHz): 18.60dBm 802.11n(HT 40 MHz): 18.55dBm 802.11ac (VHT 20 MHz): 18.61dBm 802.11ac (VHT 40 MHz): 18.65dBm 802.11ac (VHT 80 MHz): 18.56dBm
	Output Power (Max.) for UNII-2A (2TX)	802.11n(HT 20 MHz): 18.43dBm 802.11n(HT 40 MHz): 18.68dBm 802.11ac (VHT 20 MHz): 18.97dBm 802.11ac (VHT 40 MHz): 18.43dBm 802.11ac (VHT 80 MHz): 18.28dBm
	Output Power (Max.) for UNII-2C (2TX)	802.11n(HT 20 MHz): 18.76dBm 802.11n(HT 40 MHz): 18.76dBm 802.11ac (VHT 20 MHz): 18.57dBm 802.11ac (VHT 40 MHz): 18.64dBm 802.11ac (VHT 80 MHz): 18.52dBm
	Output Power (Max.) for UNII-3 (2TX)	802.11n(HT 20 MHz): 18.79dBm 802.11n(HT 40 MHz): 18.81dBm 802.11ac (VHT 20 MHz): 18.37dBm 802.11ac (VHT 40 MHz): 18.73dBm 802.11ac (VHT 80 MHz): 18.36dBm
	Power supply	<input checked="" type="checkbox"/> DC 12V for adapter
<input checked="" type="checkbox"/> Adapter : Model: KA1801A-1201500US Input: 100-240V,50/60Hz,0.55A, Max Output : 12V,1.5A ,		

Note: for more details, please refer to the User's manual of the EUT.

3 SUMMARY OF TEST RESULT

FCC Part Clause	Test Parameter	Verdict	Remark
15.407 (a) 15.407 (e)	99% , 6dB and 26dB Bandwidth	PASS	
15.407 (a)	Maximum Conducted Output Power	PASS	
15.407 (a)	Peak Power Spectral Density	PASS	
15.407 (b)	Radiated Spurious Emission	PASS	
15.407(g)	Frequency Stability	PASS	
15.407 (b)(6) 15.207	Power Line Conducted Emission	PASS	
15.407(a) 15.203	Antenna Application	PASS	
NOTE1: N/A (Not Applicable) NOTE2: According to FCC OET KDB 789033 D2 General UNII Test Procedures New Rules v01r02, In addition, the radiated test is also performed to ensure the emissions emanating from the device cabinet also comply with the applicable limits.			

RELATED SUBMITTAL(S) / GRANT(S):

This submittal(s) (test report) is intended for FCC ID: 2AF9RWH220-IOT filing to comply with Section 15.247 of the FCC Part 15, Subpart E Rules.

4 TEST METHODOLOGY

4.1 GENERAL DESCRIPTION OF APPLIED STANDARDS

According to its specifications, the EUT must comply with the requirements of the following standards:

FCC 47 CFR Part 2, Subpart J

FCC 47 CFR Part 15, Subpart E

FCC KDB 789033 D2 General UNII Test Procedures New Rules v01r04

FCC KDB 662911 D01 Multiple Transmitter Output v02r01

FCC KDB 662911 D02 MIMO With Cross Polarized Antenna V01

4.2 MEASUREMENT EQUIPMENT USED

4.2.1 Conducted Emission Test Equipment

EQUIPMENT TYPE	MFR	MODEL NUMBER	SERIAL NUMBER	LAST CAL.
Test Receiver	Rohde & Schwarz	ESCI	26115-010-0027	May 20, 2018
L.I.S.N.	Rohde & Schwarz	ENV216	101161	May 20, 2018
50Ω Coaxial Switch	Anritsu	MP59B	6100175589	May 21, 2018
Voltage Probe	Rohde & Schwarz	ESH2-Z3	100122	May 21, 2018
Pulse Limiter	Rohde & Schwarz	ESH3-Z2	100006	May 20, 2018
I.S.N	Teseq GmbH	ISN T800	30327	May 21, 2018

4.2.2 Radiated Emission Test Equipment

EQUIPMENT TYPE	MFR	MODEL NUMBER	SERIAL NUMBER	LAST CAL.
EMI Test Receiver	Rohde & Schwarz	ESU	1302.6005.26	May 21, 2018
Pre-Amplifier	HP	8447F	2944A07999	May 20, 2018
Bilog Antenna	Schwarzbeck	VULB9163	142	May 20, 2018
Loop Antenna	ARA	PLA-1030/B	1029	May 20, 2018
Horn Antenna	Schwarzbeck	BBHA 9170	BBHA9170399	May 21, 2018
Horn Antenna	Schwarzbeck	BBHA 9120	D143	May 20, 2018
Cable	Schwarzbeck	AK9513	ACRX1	May 21, 2018
Cable	Rosenberger	N/A	FP2RX2	May 21, 2018
Cable	Schwarzbeck	AK9513	CRPX1	May 21, 2018
Cable	Schwarzbeck	AK9513	CRRX2	May 21, 2018

4.2.3 Radio Frequency Test Equipment

EQUIPMENT TYPE	MFR	MODEL NUMBER	SERIAL NUMBER	LAST CAL.
Spectrum Analyzer	Agilent	E4407B	88156318	May 21, 2018
Signal Analyzer	Agilent	N9010A	My53470879	May 21, 2018
Power meter	Anritsu	ML2495A	0824006	May 21, 2018
Power sensor	Anritsu	MA2411B	0738172	May 21, 2018
Spectrum Analyzer	Agilent	E4407B	88156318	May 21, 2018

Remark: Each piece of equipment is scheduled for calibration once a year.

4.3 DESCRIPTION OF TEST MODES

The EUT has been tested under its typical operating condition.

The EUT configuration for testing is installed on RF field strength measurement to meet the Commissions requirement and operating in a manner which intends to maximize its emission characteristics in a continuous normal application.

The Transmitter was operated in the normal operating mode. The TX frequency was fixed which was for the purpose of the measurements.

Test of channel included the lowest and middle and highest frequency to perform the test, then record on this report.

Pre-defined engineering program for regulatory testing used to control the EUT for staying in continuous transmitting and receiving mode is programmed.

Wifi 5G with U-NII - 1

Frequency and Channel list for 802.11a/n (HT20)/802.11ac (VHT20):

Channel	Frequency (MHz)	Channel	Frequency (MHz)	Channel	Frequency (MHz)
36	5180	44	5220		
40	5200	48	5240		

Frequency and Channel list for 802.11n (HT40)/ 802.11ac (VHT40):

Channel	Frequency (MHz)	Channel	Frequency (MHz)	Channel	Frequency (MHz)
38	5190				
46	5230				

Frequency and Channel list for 802.11ac Wave2 (VHT80):

Channel	Frequency (MHz)	Channel	Frequency (MHz)	Channel	Frequency (MHz)
42	5210				

Test Frequency and Channel for 802.11a/n (HT20)/802.11ac (VHT20):

Lowest Frequency		Middle Frequency		Highest Frequency	
Channel	Frequency (MHz)	Channel	Frequency (MHz)	Channel	Frequency (MHz)
36	5180	40	5200	48	5240

Test Frequency and channel for 802.11n (HT40)/ 802.11ac (VHT40):

Lowest Frequency		Middle Frequency		Highest Frequency	
Channel	Frequency (MHz)	Channel	Frequency (MHz)	Channel	Frequency (MHz)
38	5190	N/A	N/A	46	5230

Test Frequency and channel for 802.11ac Wave2 (VHT80):

Lowest Frequency		Middle Frequency		Highest Frequency	
Channel	Frequency (MHz)	Channel	Frequency (MHz)	Channel	Frequency (MHz)
42	5210	N/A	N/A	N/A	N/A

Wifi 5G with U-NII -2A

Frequency and Channel list for 802.11a/n (HT20)/802.11ac (VHT20):

Channel	Frequency (MHz)	Channel	Frequency (MHz)	Channel	Frequency (MHz)
52	5260	60	5300		
56	5280	64	5320		

Frequency and Channel list for 802.11n (HT40)/ 802.11ac (VHT40):

Channel	Frequency (MHz)	Channel	Frequency (MHz)	Channel	Frequency (MHz)
54	5270				
62	5310				

Frequency and Channel list for 802.11ac (VHT80):

Channel	Frequency (MHz)	Channel	Frequency (MHz)	Channel	Frequency (MHz)
58	5290				

Test Frequency and Channel for 802.11a/n (HT20)/802.11ac (VHT20):

Lowest Frequency		Middle Frequency		Highest Frequency	
Channel	Frequency (MHz)	Channel	Frequency (MHz)	Channel	Frequency (MHz)
52	5260	56	5280	64	5320

Test Frequency and channel for 802.11n (HT40)/ 802.11ac (VHT40):

Lowest Frequency		Middle Frequency		Highest Frequency	
Channel	Frequency (MHz)	Channel	Frequency (MHz)	Channel	Frequency (MHz)
54	5270	N/A	N/A	62	5310

Test Frequency and channel for 802.11ac (VHT80):

Lowest Frequency		Middle Frequency		Highest Frequency	
Channel	Frequency (MHz)	Channel	Frequency (MHz)	Channel	Frequency (MHz)
58	5290				

Wifi 5G with U-NII -2C

Frequency and Channel list for 802.11a/n (HT20)/802.11ac (VHT20):

Channel	Frequency (MHz)	Channel	Frequency (MHz)	Channel	Frequency (MHz)
100	5500	116	5580	132	5660
104	5520	120	5600	136	5680
108	5540	124	5620	140	5700
112	5560	128	5640		

Frequency and Channel list for 802.11n (HT40)/ 802.11ac (VHT40):

Channel	Frequency (MHz)	Channel	Frequency (MHz)	Channel	Frequency (MHz)
102	5510	118	5590	134	5670
110	5550	126	5630		

Frequency and Channel list for 802.11ac (VHT80):

Channel	Frequency (MHz)	Channel	Frequency (MHz)	Channel	Frequency (MHz)
106	5530	122	5610		

Test Frequency and Channel for 802.11a/n (HT20)/802.11ac (VHT20):

Lowest Frequency		Middle Frequency		Highest Frequency	
Channel	Frequency (MHz)	Channel	Frequency (MHz)	Channel	Frequency (MHz)
100	5500	116	5580	140	5700

Test Frequency and channel for 802.11n (HT40)/ 802.11ac (VHT40):

Lowest Frequency		Middle Frequency		Highest Frequency	
Channel	Frequency (MHz)	Channel	Frequency (MHz)	Channel	Frequency (MHz)
102	5510	110	5550	134	5670

Test Frequency and channel for 802.11ac (VHT80):

Lowest Frequency		Middle Frequency		Highest Frequency	
Channel	Frequency (MHz)	Channel	Frequency (MHz)	Channel	Frequency (MHz)
106	5530				

Wifi 5G with U-NII -3

Frequency and Channel list for 802.11a/n (HT20)/802.11ac (VHT20):

Channel	Frequency (MHz)	Channel	Frequency (MHz)	Channel	Frequency (MHz)
149	5745	157	5785	165	5825
153	5765	161	5805		

Frequency and Channel list for 802.11n (HT40)/ 802.11ac (VHT40):

Channel	Frequency (MHz)	Channel	Frequency (MHz)	Channel	Frequency (MHz)
151	5755				
159	5795				

Frequency and Channel list for 802.11ac (VHT80):

Channel	Frequency (MHz)	Channel	Frequency (MHz)	Channel	Frequency (MHz)
155	5775				

Test Frequency and Channel for 802.11a/n (HT20)/802.11ac (VHT20):

Lowest Frequency		Middle Frequency		Highest Frequency	
Channel	Frequency (MHz)	Channel	Frequency (MHz)	Channel	Frequency (MHz)
149	5745	157	5785	165	5825

Test Frequency and channel for 802.11n (HT40)/ 802.11ac (VHT40):

Lowest Frequency		Middle Frequency		Highest Frequency	
Channel	Frequency (MHz)	Channel	Frequency (MHz)	Channel	Frequency (MHz)
151	5755	N/A	N/A	159	5795

Test Frequency and channel for 802.11ac (VHT80):

Lowest Frequency		Middle Frequency		Highest Frequency	
Channel	Frequency (MHz)	Channel	Frequency (MHz)	Channel	Frequency (MHz)
155	5775				

5 FACILITIES AND ACCREDITATIONS

5.1 FACILITIES

All measurement facilities used to collect the measurement data are located at

Bldg 69, Majialong Industry Zone District, Nanshan District, Shenzhen, China

The sites are constructed in conformance with the requirements of ANSI C63.7, ANSI C63.10 and CISPR Publication 22.

5.2 LABORATORY ACCREDITATIONS AND LISTINGS

Site Description

EMC Lab.

: Accredited by CNAS,2016.10.24

The certificate is valid until 2022.10.28

The Laboratory has been assessed and proved to be in compliance with CNAS-CL01:2006 (identical to ISO/IEC 17025:2005)

The Certificate Registration Number is L2291.

Accredited by TUV Rheinland Shenzhen 2016.5.19

The Laboratory has been assessed according to the requirements ISO/IEC 17025.

Accredited by FCC, August 03, 2017

Designation Number: CN1204

Test Firm Registration Number: 882943

Accredited by A2LA, July 31, 2017

The Certificate Registration Number is 4321.01.

Accredited by Industry Canada, November 24, 2015

The Certificate Registration Number is 4480A

Name of Firm

: EMTEK(SHENZHEN) CO., LTD.

Site Location

: Bldg 69, Majialong Industry Zone,
Nanshan District, Shenzhen, Guangdong, China

6 TEST SYSTEM UNCERTAINTY

The following measurement uncertainty levels have been estimated for tests performed on the apparatus:

Parameter	Uncertainty
Radio Frequency	$\pm 1 \times 10^{-5}$
Maximum Peak Output Power Test	$\pm 1.0\text{dB}$
Conducted Emissions Test	$\pm 2.0\text{dB}$
Radiated Emission Test	$\pm 2.0\text{dB}$
Power Density	$\pm 2.0\text{dB}$
Occupied Bandwidth Test	$\pm 1.0\text{dB}$
Band Edge Test	$\pm 3\text{dB}$
All emission, radiated	$\pm 3\text{dB}$
Antenna Port Emission	$\pm 3\text{dB}$
Temperature	$\pm 0.5^{\circ}\text{C}$
Humidity	$\pm 3\%$

Measurement Uncertainty for a level of Confidence of 95%

7 SETUP OF EQUIPMENT UNDER TEST

7.1 RADIO FREQUENCY TEST SETUP

The WLAN component's antenna ports(s) of the EUT are connected to the measurement instrument per an appropriate attenuator. The EUT is controlled by PC/software to emit the specified signals for the purpose of measurements.

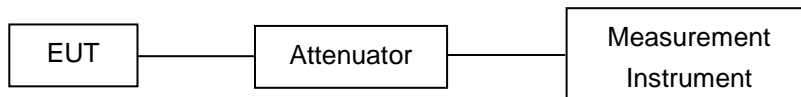

7.2 RADIO FREQUENCY TEST SETUP

The test site semi-anechoic chamber has met the requirement of NSA tolerance 4 dB according to the standards: ANSI C63.10. The test distance is 3m. The setup is according to the requirements in Section 13.1.4.1 of ANSI C63.10-2013 and CAN/CSA-CEI/IEC CISPR 22.

Below 30MHz:

The EUT is placed on a turntable 0.8 meters above the ground in the chamber, 3 meter away from the antenna (loop antenna). The Antenna should be positioned with its plane vertical at the specified distance from the EUT and rotated about its vertical axis for maximum response at each azimuth about the EUT. The center of the loop shall be 1 m above the ground. For certain applications, the loop antenna plane may also need to be positioned horizontally at the specified distance from the EUT.

Above 30MHz:

The EUT is placed on a turntable 0.8 meters above the ground in the chamber, 3 meter away from the antenna. The maximal emission value is acquired by adjusting the antenna height, polarisation and turntable azimuth. Normally, the height range of antenna is 1 m to 4 m, the azimuth range of turntable is 0° to 360°, and the receive antenna has two polarizations Vertical (V) and Horizontal (H).

Above 1GHz:

(Note: the FCC's permission to use 1.5m as an alternative per TCBC Conf call of Dec. 2, 2014.)

The EUT is placed on a turntable 1.5 meters above the ground in the chamber, 3 meter away from the antenna. The maximal emission value is acquired by adjusting the antenna height, polarisation and turntable azimuth. Normally, the height range of antenna is 1 m to 4 m, the azimuth range of turntable is 0° to 360°, and the receive antenna has two polarizations Vertical (V) and Horizontal (H).

(a) Radiated Emission Test Set-Up, Frequency Below 30MHz

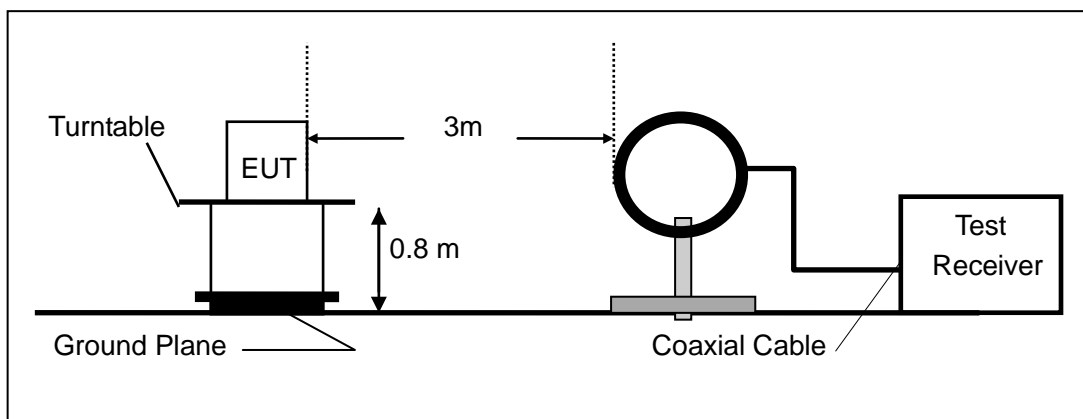

(b) Radiated Emission Test Set-Up, Frequency Below 1000MHz

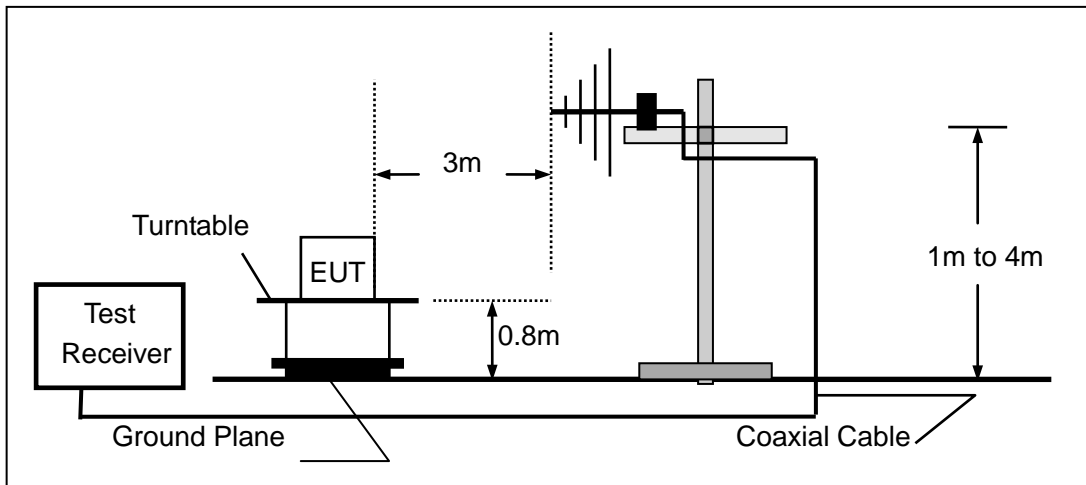

(c) Radiated Emission Test Set-Up, Frequency above 1000MHz

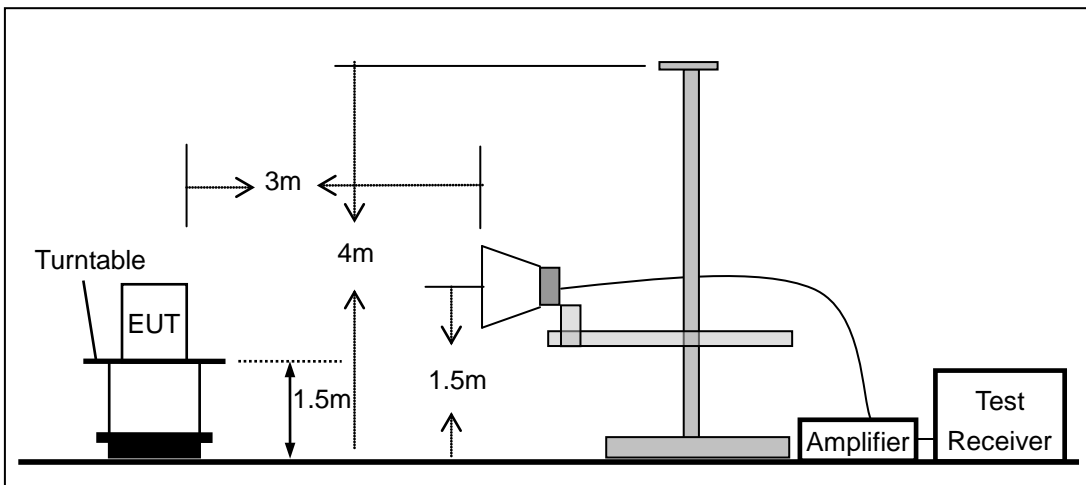

7.3 CONDUCTED EMISSION TEST SETUP

The mains cable of the EUT (maybe per AC/DC Adapter) must be connected to LISN. The LISN shall be placed 0.8 m from the boundary of EUT and bonded to a ground reference plane for LISN mounted on top of the ground reference plane. This distance is between the closest points of the LISN and the EUT. All other units of the EUT and associated equipment shall be at least 0.8m from the LISN.

Ground connections, where required for safety purposes, shall be connected to the reference ground point of the LISN and, where not otherwise provided or specified by the manufacturer, shall be of same length as the mains cable and run parallel to the mains connection at a separation distance of not more than 0.1 m.

According to the requirements in Section 13.1.4.1 of ANSI C63.10-2013 Conducted emissions from the EUT measured in the frequency range between 0.15 MHz and 30 MHz using CISPR Quasi-Peak and average detector mode.

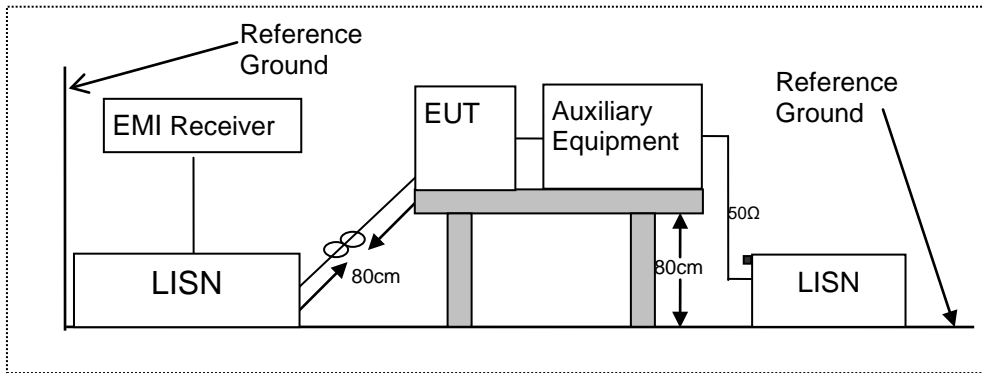

7.4 BLOCK DIAGRAM CONFIGURATION OF TEST SYSTEM

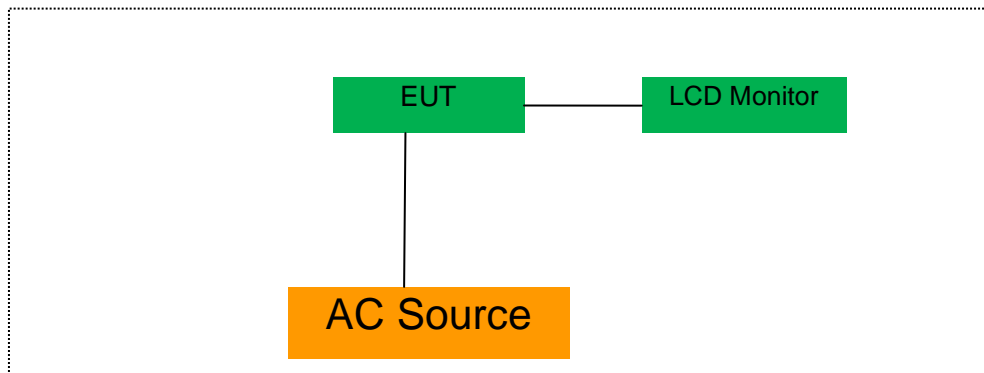

7.5 SUPPORT EQUIPMENT

EUT Cable List and Details			
Cable Description	Length (m)	Shielded/Unshielded	With / Without Ferrite
Adapter cable	1.5	Unshielded	Without Ferrite

Auxiliary Cable List and Details			
Cable Description	Length (m)	Shielded/Unshielded	With / Without Ferrite
HDMI cable	1.5	Shielded	With Ferrite

Auxiliary Equipment List and Details			
Description	Manufacturer	Model	Serial Number
Notebook	acer	ZR1	LXTECOCO76643158 372500
LCD Monitor	SONY	SDM-S53/B T8UC7	P-17465811-F

Notes:

- 1.All the equipment/cables were placed in the worst-case configuration to maximize the emission during the test.
- 2.Grounding was established in accordance with the manufacturer's requirements and conditions for the intended use.

8 TEST REQUIREMENTS

8.1 BANDWIDTH MEASUREMENT

8.1.1 Applicable Standard

According to FCC Part 15.407(a)(1) for UNII Band I
According to FCC Part 15.407(a)(2) for UNII Band II-A and UNII Band II-C
According to FCC Part 15.407(a)(3) for UNII Band III
According to FCC Part 15.407(e) for UNII Band III
According to 789033 D02 Section II(C)
According to 789033 D02 Section II(D)

8.1.2 Conformance Limit

(1) For the band 5.15-5.25 GHz.

(iv) For mobile and portable client devices in the 5.15-5.25 GHz band, the maximum conducted output power over the frequency band of operation shall not exceed 250 mW provided the maximum antenna gain does not exceed 6 dBi. In addition, the maximum power spectral density shall not exceed 11 dBm in any 1 megahertz band. If transmitting antennas of directional gain greater than 6 dBi are used, both the maximum conducted output power and the maximum power spectral density shall be reduced by the amount in dB that the directional gain of the antenna exceeds 6 dBi.

(2) For the 5.25-5.35 GHz and 5.47-5.725 GHz bands, the maximum conducted output power over the frequency bands of operation shall not exceed the lesser of 250 mW or 11 dBm + 10 log B, where B is the 26 dB emission bandwidth in megahertz. In addition, the maximum power spectral density shall not exceed 11 dBm in any 1 megahertz band. If transmitting antennas of directional gain greater than 6 dBi are used, both the maximum conducted output power and the maximum power spectral density shall be reduced by the amount in dB that the directional gain of the antenna exceeds 6 dBi.

(3) For the band 5.725-5.85 GHz, the maximum conducted output power over the frequency band of operation shall not exceed 1 W. In addition, the maximum power spectral density shall not exceed 30 dBm in any 500-kHz band. If transmitting antennas of directional gain greater than 6 dBi are used, both the maximum conducted output power and the maximum power spectral density shall be reduced by the amount in dB that the directional gain of the antenna exceeds 6 dBi. However, fixed point-to-point U-NII devices operating in this band may employ transmitting antennas with directional gain greater than 6 dBi without any corresponding reduction in transmitter conducted power. Fixed, point-to-point operations exclude the use of point-to-multipoint systems, omnidirectional applications, and multiple collocated transmitters transmitting the same information. The operator of the U-NII device, or if the equipment is professionally installed, the installer, is responsible for ensuring that systems employing high gain directional antennas are used exclusively for fixed, point-to-point operations.

(e) Within the 5.725-5.85 GHz band, the minimum 6 dB bandwidth of U-NII devices shall be at least 500 kHz.

8.1.3 Test Configuration

Test according to clause 6.1 radio frequency test setup

8.1.4 Test Procedure

According to 789033 D02 v01r02 section C&D, the following is the measurement procedure.

1. Emission Bandwidth (EBW)

- a) Set RBW = approximately 1% of the emission bandwidth.
- b) Set the VBW > RBW.
- c) Detector = Peak.
- d) Trace mode = max hold.
- e) Measure the maximum width of the emission that is 26 dB down from the maximum of the emission. Compare this with the RBW setting of the analyzer. Readjust RBW and repeat measurement as needed until the RBW/EBW ratio is approximately 1%.

2. Minimum Emission Bandwidth for the band 5.725-5.85 GHz

Section 15.407(e) specifies the minimum 6 dB emission bandwidth of at least 500 KHz for the band 5.715-5.85 GHz. The following procedure shall be used for measuring this bandwidth:

- a) Set RBW = 100 kHz.
- b) Set the video bandwidth (VBW) $\geq 3 \times$ RBW.
- c) Detector = Peak.
- d) Trace mode = max hold.
- e) Sweep = auto couple.
- f) Allow the trace to stabilize.
- g) Measure the maximum width of the emission that is constrained by the frequencies associated with the two outermost amplitude points (upper and lower frequencies) that are attenuated by 6 dB relative to the maximum level measured in the fundamental emission.

Note: The automatic bandwidth measurement capability of a spectrum analyzer or EMI receiver may be employed if it implements the functionality described above.

D. 99 Percent Occupied Bandwidth

The 99-percent occupied bandwidth is the frequency bandwidth such that, below its lower and above its upper frequency limits, the mean powers are each equal to 0.5 % of the total mean power of the given emission. Measurement of the 99-percent occupied bandwidth is required only as a condition for using the optional band-edge measurement techniques described in section II.G.3.d). Measurements of 99-percent occupied bandwidth may also optionally be used in lieu of the EBW to 789033 D02 v01r02 General UNII Test Procedures New Rules v01 define the minimum frequency range over which the spectrum is integrated when measuring maximum conducted output power as described in section II.E. However, the EBW must be measured to determine bandwidth dependent limits on maximum conducted output power in accordance with 15.407(a).

The following procedure shall be used for measuring (99 %) power bandwidth:

1. Set center frequency to the nominal EUT channel center frequency.
2. Set span = 1.5 times to 5.0 times the OBW.
3. Set RBW = 1 % to 5 % of the OBW
4. Set VBW $\geq 3 \cdot$ RBW
5. Video averaging is not permitted. Where practical, a sample detection and single sweep mode shall be used. Otherwise, peak detection and max hold mode (until the trace stabilizes) shall be used.
6. Use the 99 % power bandwidth function of the instrument (if available).
7. If the instrument does not have a 99 % power bandwidth function, the trace data points are recovered and directly summed in power units. The recovered amplitude data points, beginning at the lowest frequency, are placed in a running sum until 0.5 % of the total is reached; that frequency is recorded as the lower frequency. The process is repeated until 99.5 % of the total is reached; that frequency is recorded as the upper frequency. The 99% occupied bandwidth is the difference between these two frequencies.

8.1.5 Test Results

5150-5250MHz

Test Mode	Test Channel MHz		26 dB Bandwidth MHz	99% Bandwidth MHz	Verdict
802.11a	CH36	5180	21.57	17.028	Pass
	CH40	5200	21.26	16.875	Pass
	CH48	5240	21.36	16.873	Pass
802.11n-HT20	CH36	5180	21.46	17.996	Pass
	CH40	5200	21.25	17.889	Pass
	CH48	5240	21.60	17.945	Pass
802.11ac(VHT20)	CH36	5180	21.58	17.882	Pass
	CH40	5200	21.40	17.889	Pass
	CH48	5240	21.51	17.950	Pass
802.11n-HT40	CH38	5190	39.87	36.314	Pass
	CH46	5230	39.33	36.280	Pass
802.11ac(VHT40)	CH38	5190	40.12	36.270	Pass
	CH46	5230	40.22	36.372	Pass
802.11ac(VHT80)	CH42	5210	81.33	75.839	Pass

Emission Bandwidth&99% Occupied Bandwidth U-NII - 1
Test Model 802.11a Frequency(MHz) 5180

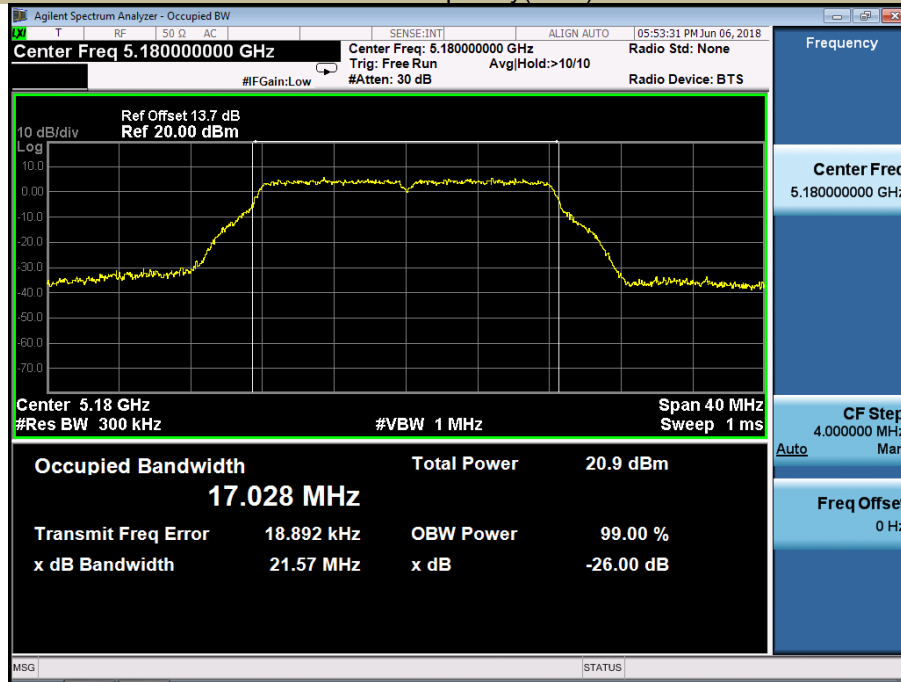

Emission Bandwidth&99% Occupied Bandwidth U-NII - 1
Test Model 802.11a Frequency(MHz) 5200

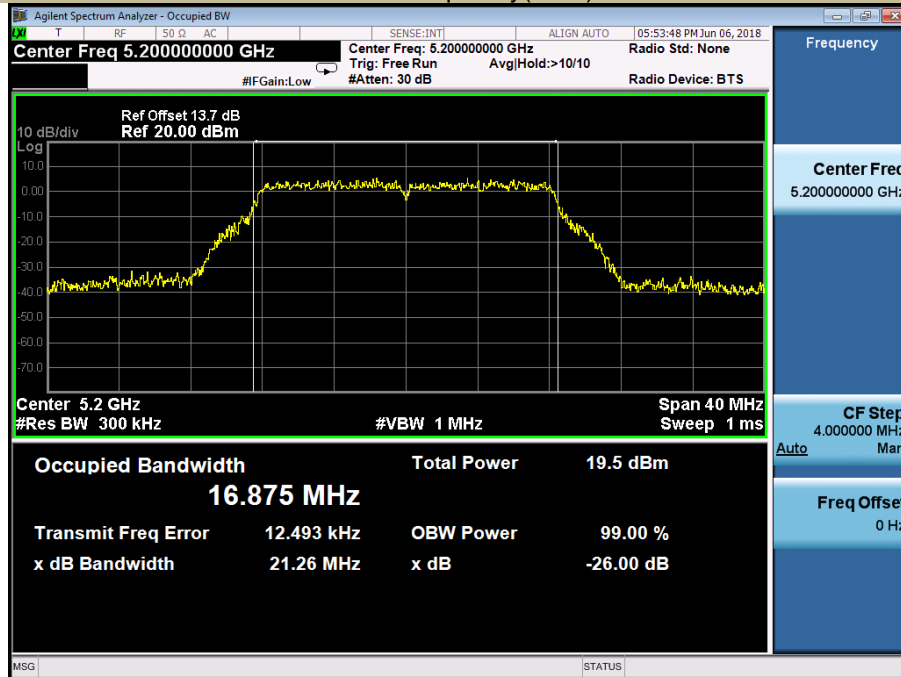

Emission Bandwidth&99% Occupied Bandwidth U-NII - 1
Test Model 802.11a Frequency(MHz) 5240

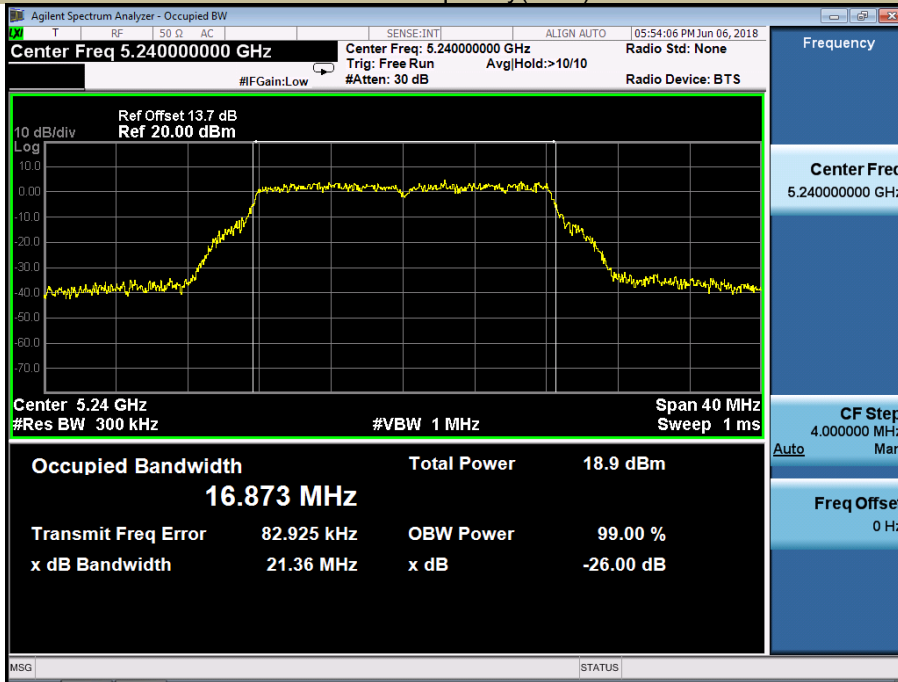

Emission Bandwidth&99% Occupied Bandwidth U-NII - 1
Test Model 802.11n-HT20 Frequency(MHz) 5180

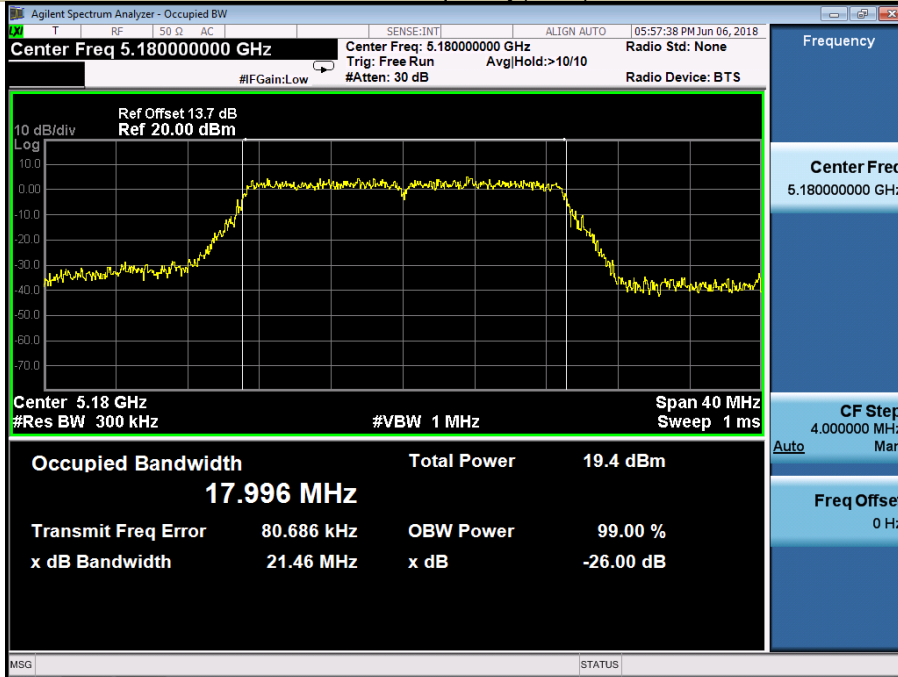

Emission Bandwidth&99% Occupied Bandwidth U-NII - 1
Test Model 802.11n-HT20 Frequency(MHz) 5200

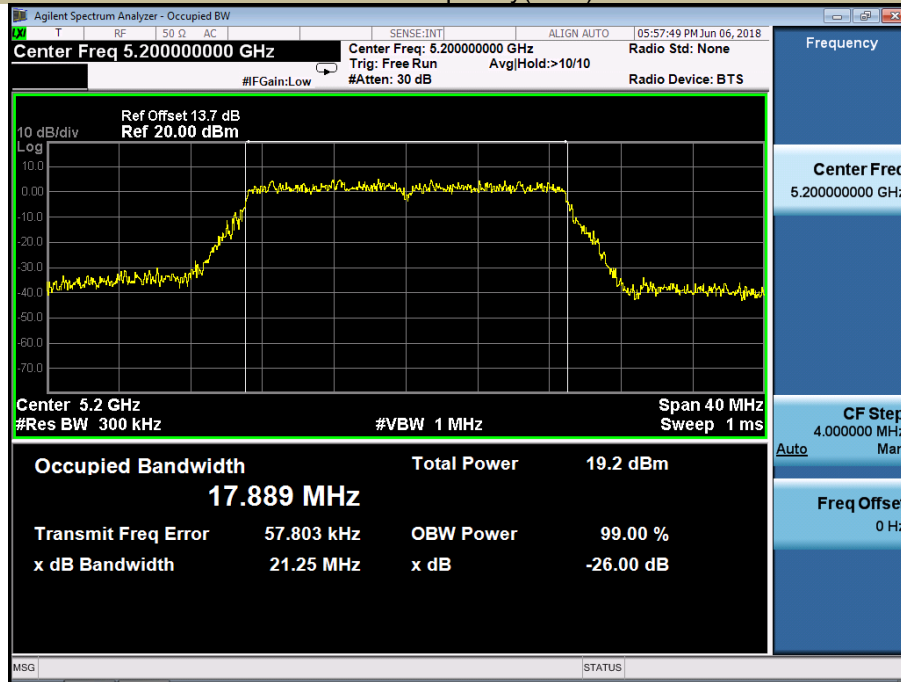

Emission Bandwidth&99% Occupied Bandwidth U-NII - 1
Test Model 802.11n-HT20 Frequency(MHz) 5240

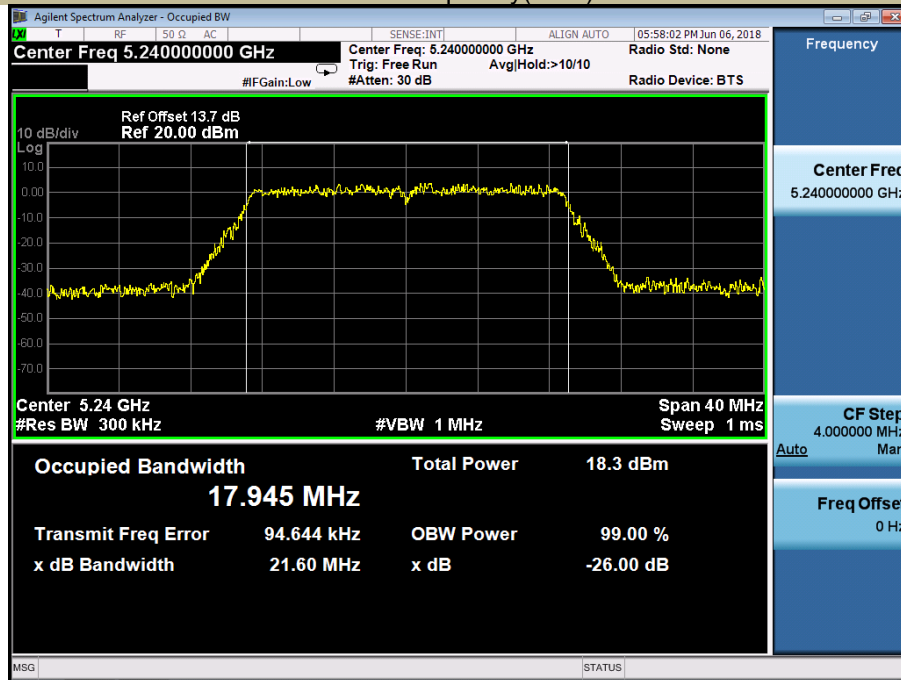

Emission Bandwidth&99% Occupied Bandwidth U-NII - 1
Test Model 802.11ac(HT20) Frequency(MHz) 5180

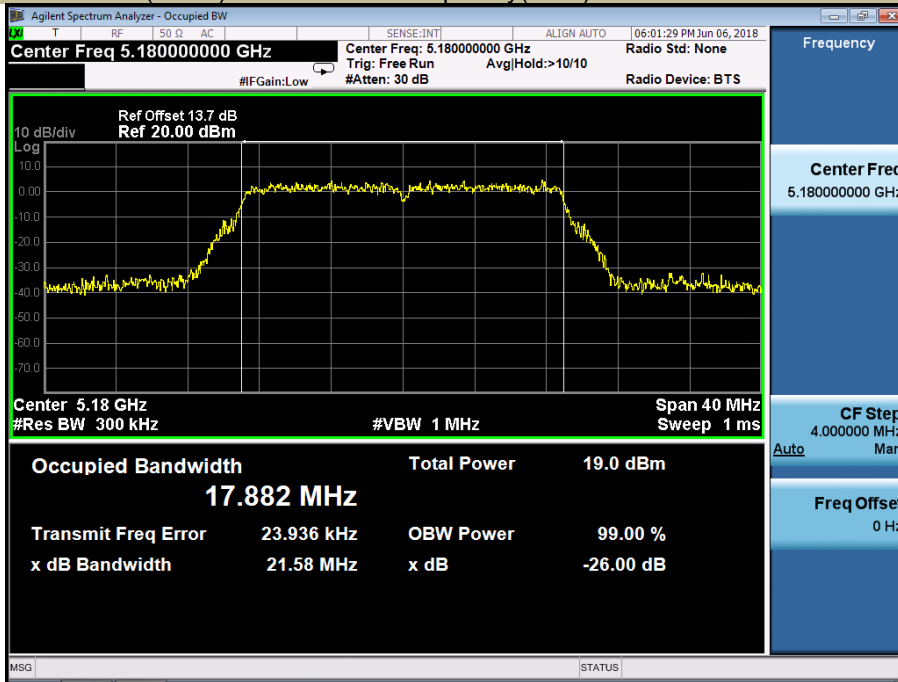

Emission Bandwidth&99% Occupied Bandwidth U-NII - 1
Test Model 802.11ac(HT20) Frequency(MHz) 5200

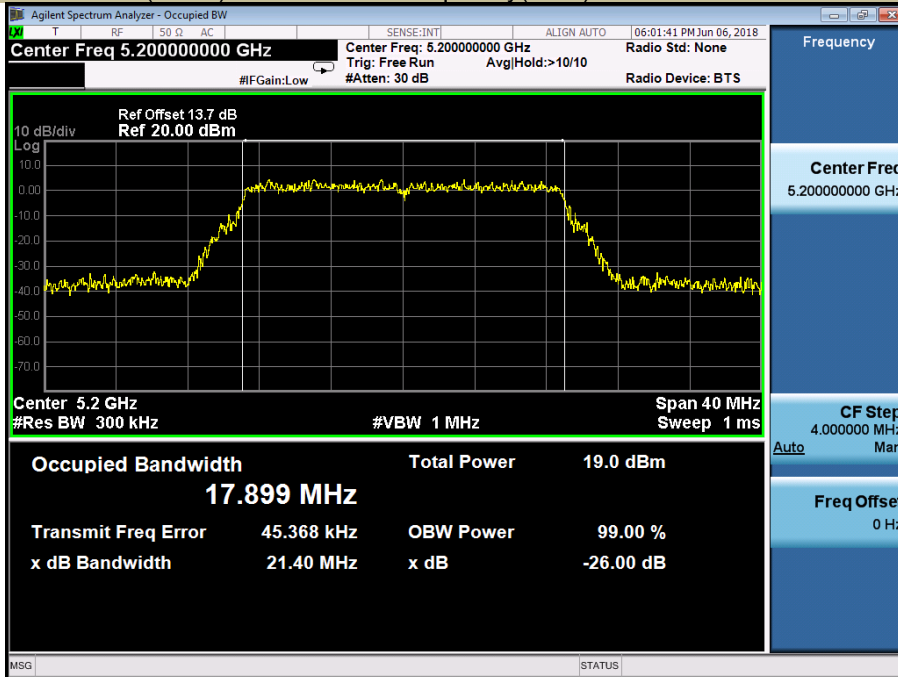

Emission Bandwidth&99% Occupied Bandwidth U-NII - 1
 Test Model 802.11ac(HT20) Frequency(MHz) 5240

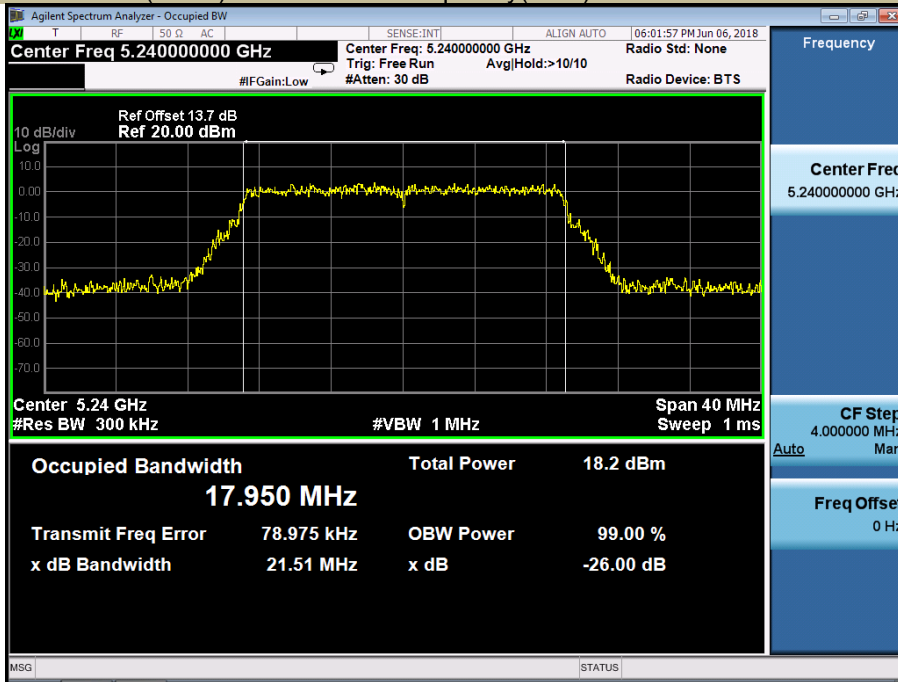

Emission Bandwidth&99% Occupied Bandwidth U-NII - 1
 Test Model 802.11n-HT40 Frequency(MHz) 5190

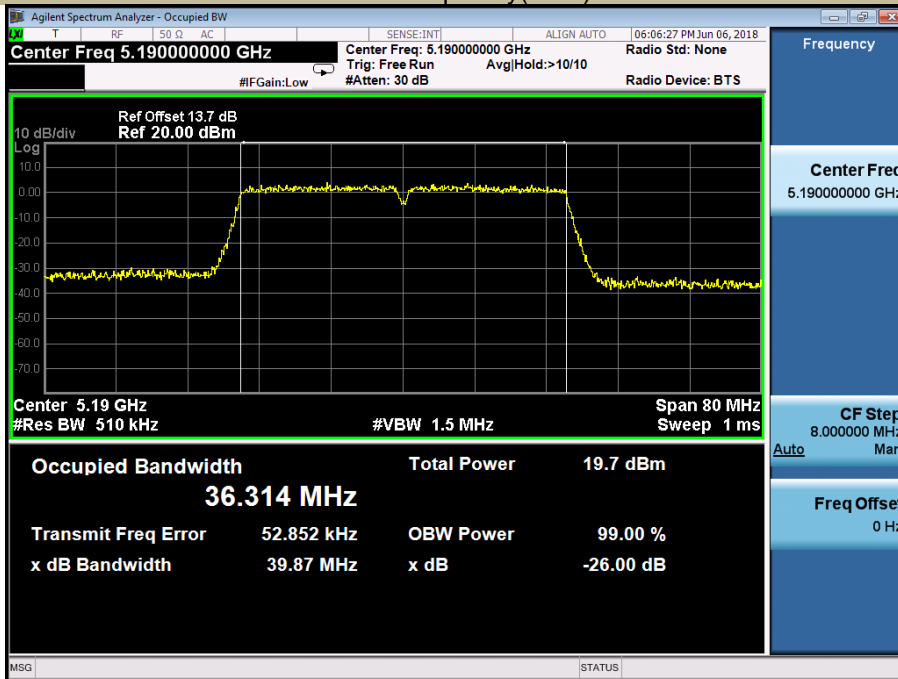

Emission Bandwidth & 99% Occupied Bandwidth U-NII - 1
 Test Model 802.11n-HT40 Frequency(MHz) 5230

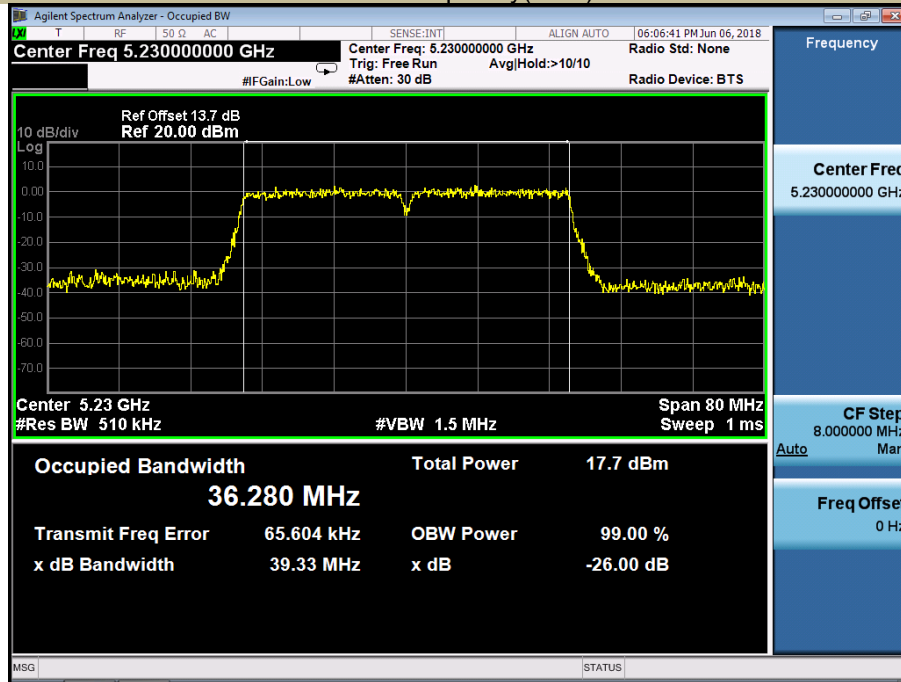

Emission Bandwidth & 99% Occupied Bandwidth U-NII - 1
 Test Model 802.11ac(HT40) Frequency(MHz) 5190

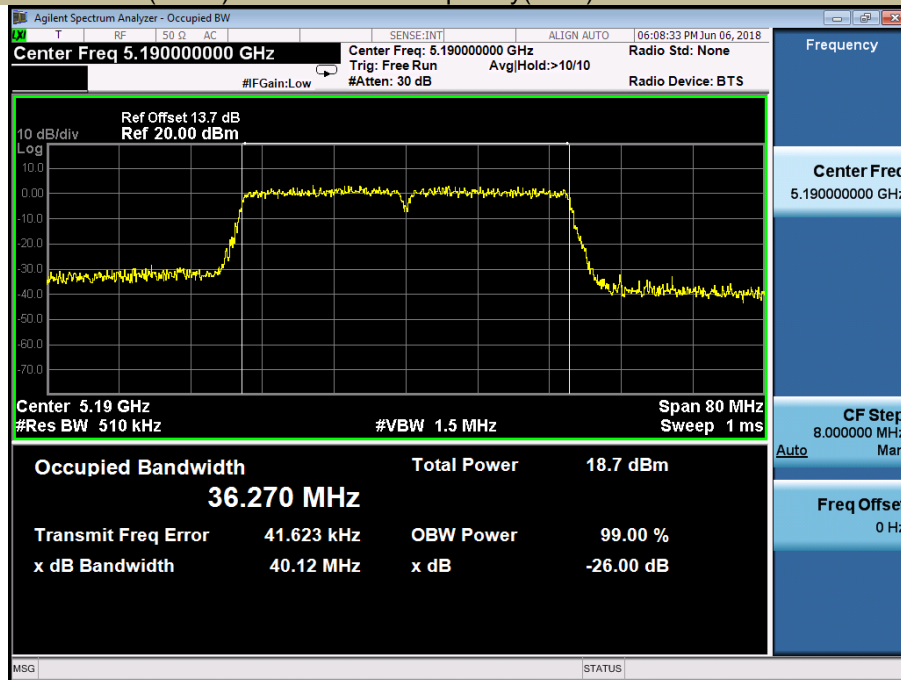

Emission Bandwidth&99% Occupied Bandwidth U-NII - 1
 Test Model 802.11ac(HT40) Frequency(MHz) 5230

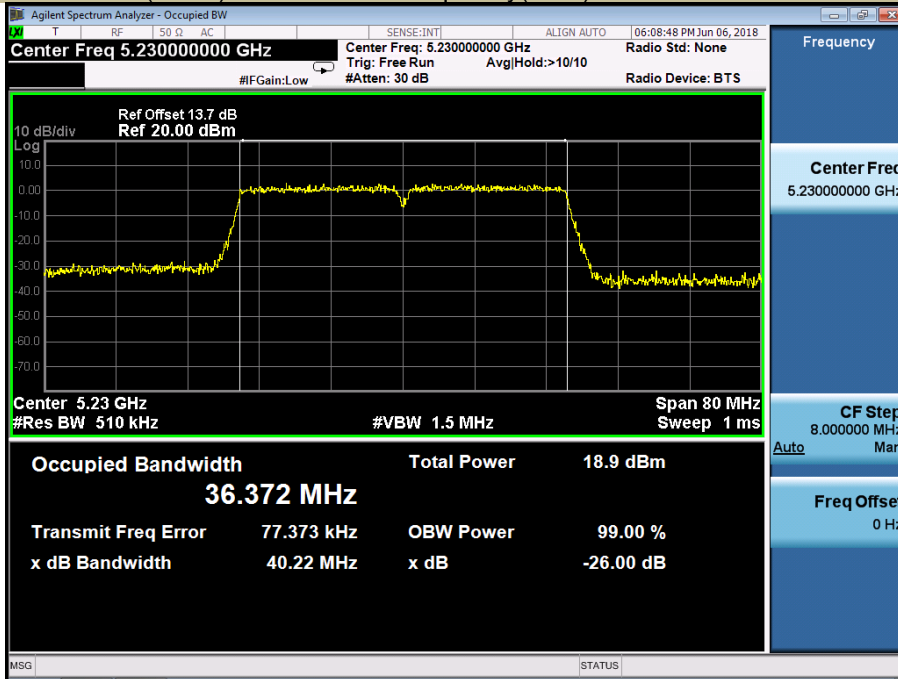

Emission Bandwidth&99% Occupied Bandwidth U-NII - 1
 Test Model 802.11ac 80 Frequency(MHz) 5210

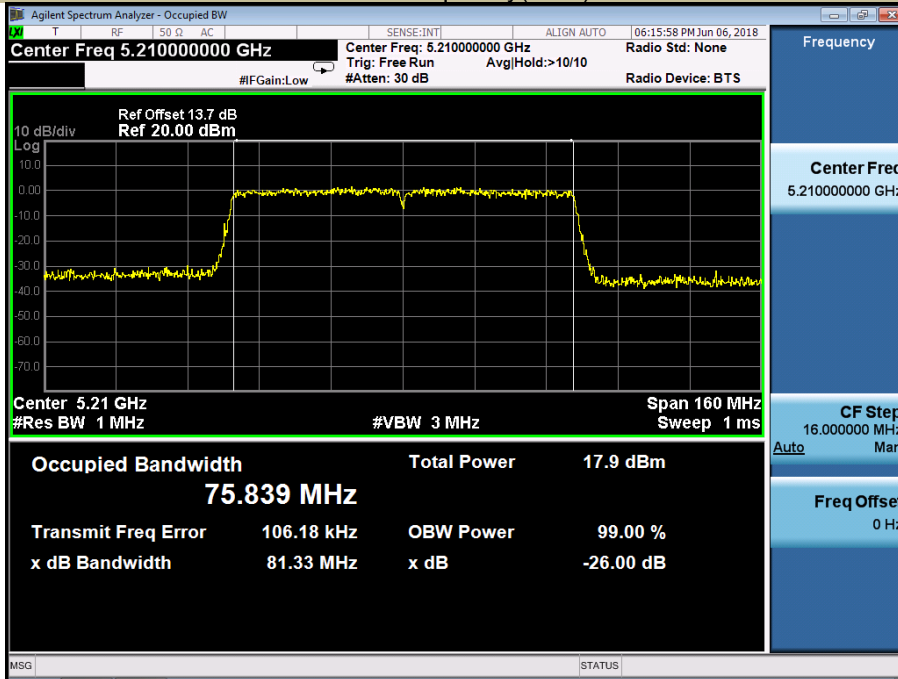

5250-5350MHz

Test Mode	Test Channel MHz		26 dB Bandwidth MHz	99% Bandwidth MHz	Verdict
802.11a	CH52	5260	21.33	16.833	Pass
	CH56	5280	21.35	16.897	Pass
	CH64	5320	21.47	16.907	Pass
802.11n-HT20	CH52	5260	21.64	17.904	Pass
	CH56	5280	21.62	18.016	Pass
	CH64	5320	21.45	17.963	Pass
802.11ac(VHT20)	CH52	5260	21.46	17.960	Pass
	CH56	5280	21.45	17.968	Pass
	CH64	5320	21.42	17.900	Pass
802.11n-HT40	CH54	5270	39.98	36.322	Pass
	CH62	5310	39.75	36.263	Pass
802.11ac(VHT40)	CH54	5270	39.57	36.262	Pass
	CH62	5310	39.85	36.314	Pass
802.11ac(VHT80)	CH58	5290	80.69	75.792	Pass

Emission Bandwidth&99% Occupied Bandwidth U-NII – 2A
 Test Model 802.11a Frequency(MHz) 5260

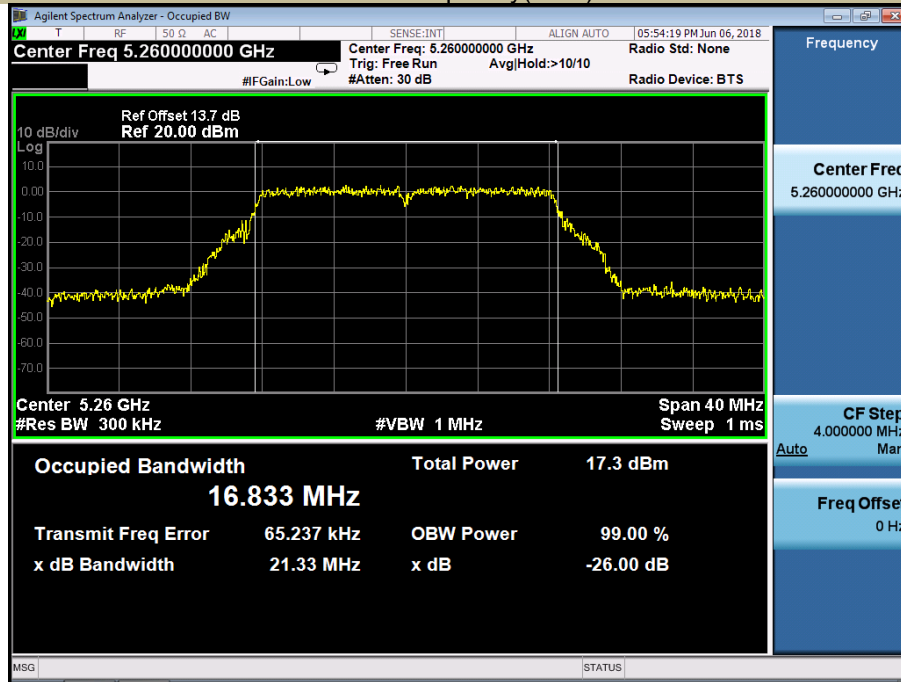

Emission Bandwidth&99% Occupied Bandwidth U-NII – 2A
 Test Model 802.11a Frequency(MHz) 5280

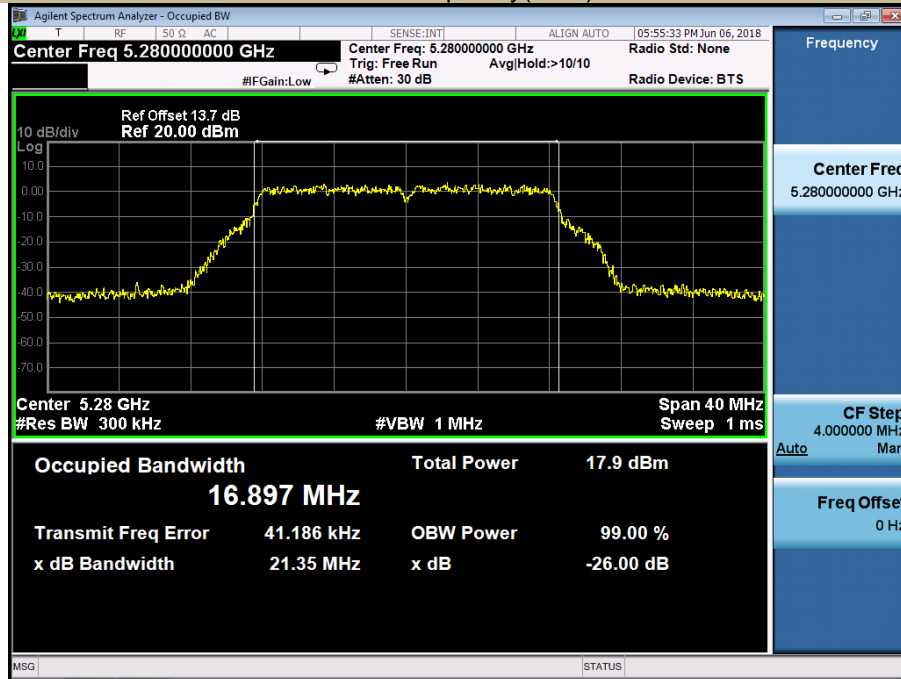

Emission Bandwidth&99% Occupied Bandwidth U-NII – 2A
Test Model 802.11a Frequency(MHz) 5320

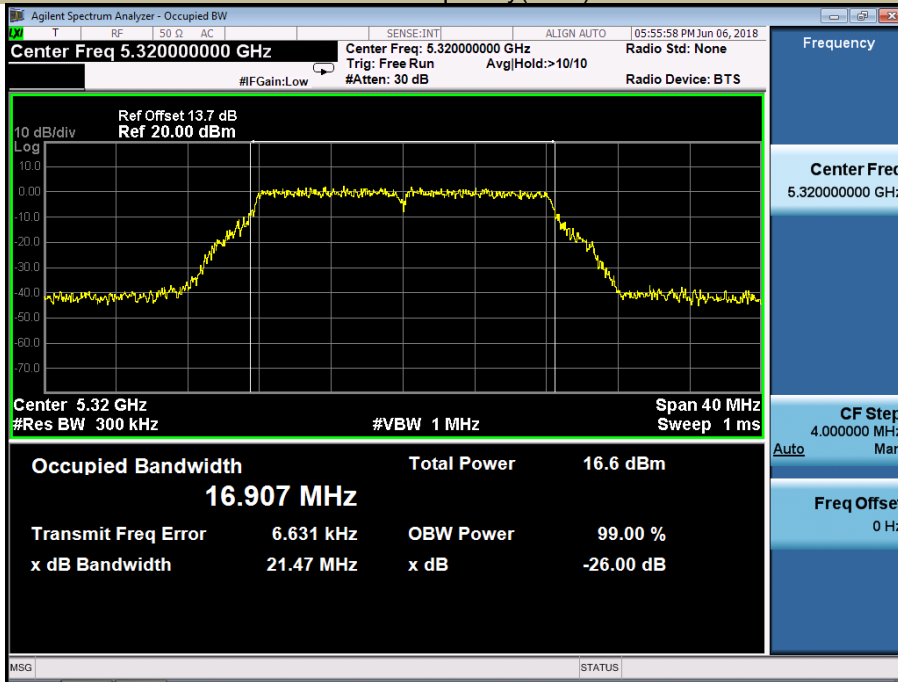

Emission Bandwidth&99% Occupied Bandwidth U-NII – 2A
Test Model 802.11n-HT20 Frequency(MHz) 5260

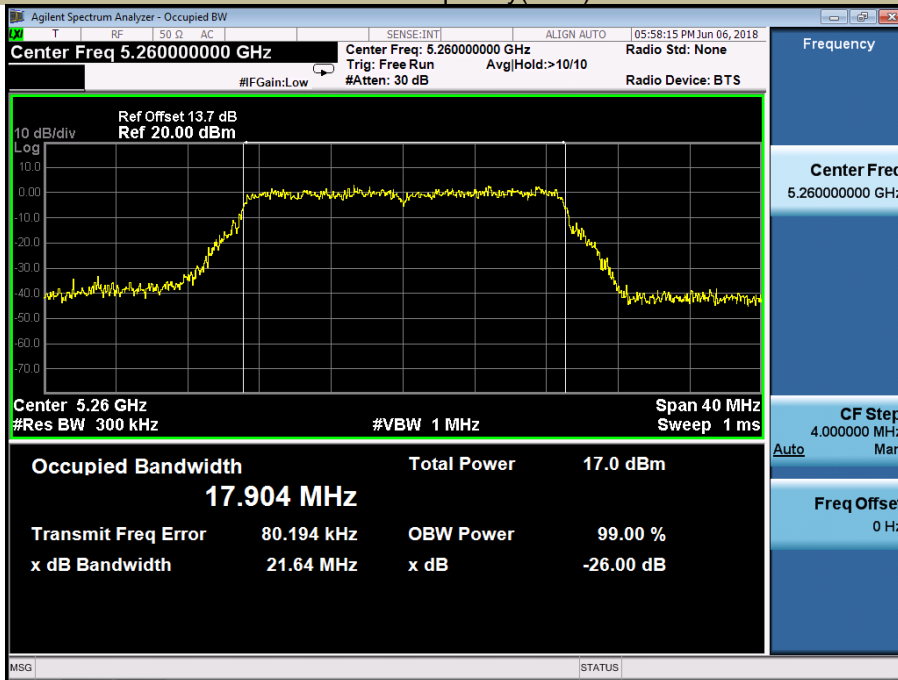

Emission Bandwidth&99% Occupied Bandwidth U-NII – 2A
 Test Model 802.11n-HT20 Frequency(MHz) 5280

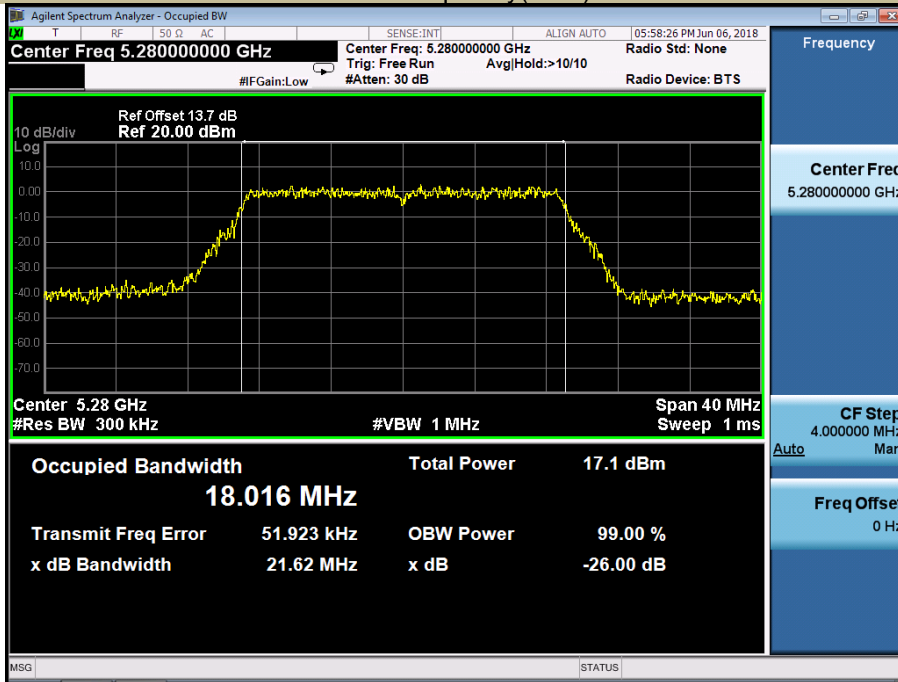

Emission Bandwidth&99% Occupied Bandwidth U-NII – 2A
 Test Model 802.11n-HT20 Frequency(MHz) 5320

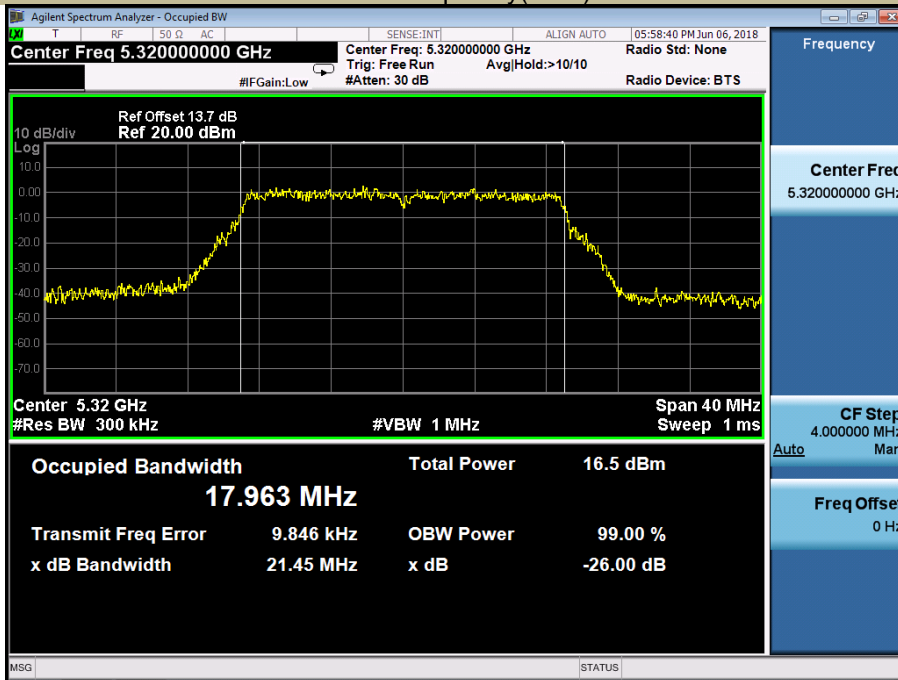

Emission Bandwidth&99% Occupied Bandwidth U-NII – 2A
 Test Model 802.11ac(HT20) Frequency(MHz) 5260

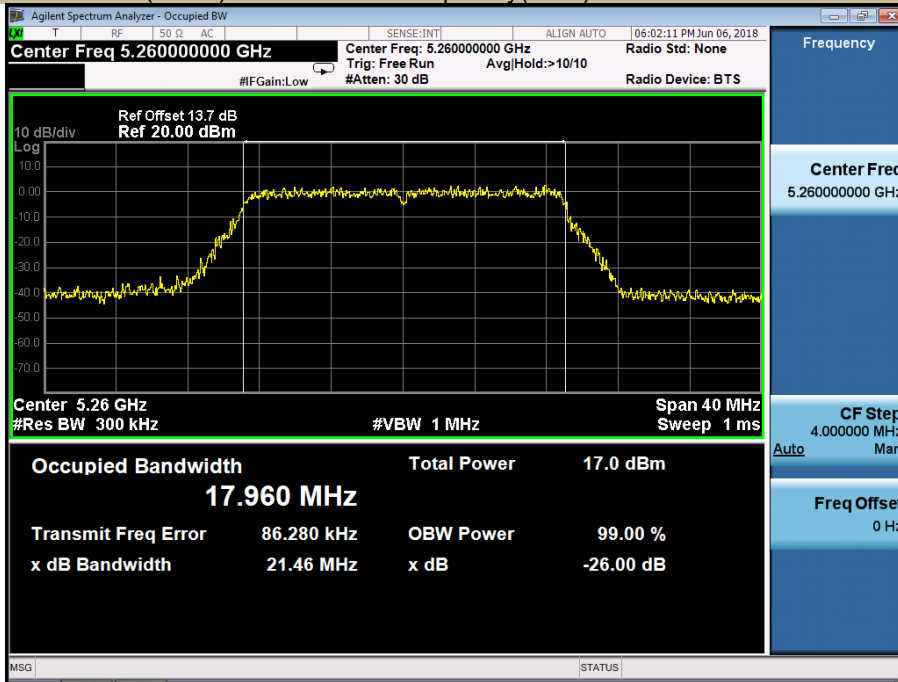

Emission Bandwidth&99% Occupied Bandwidth U-NII – 2A
 Test Model 802.11ac(HT20) Frequency(MHz) 5280

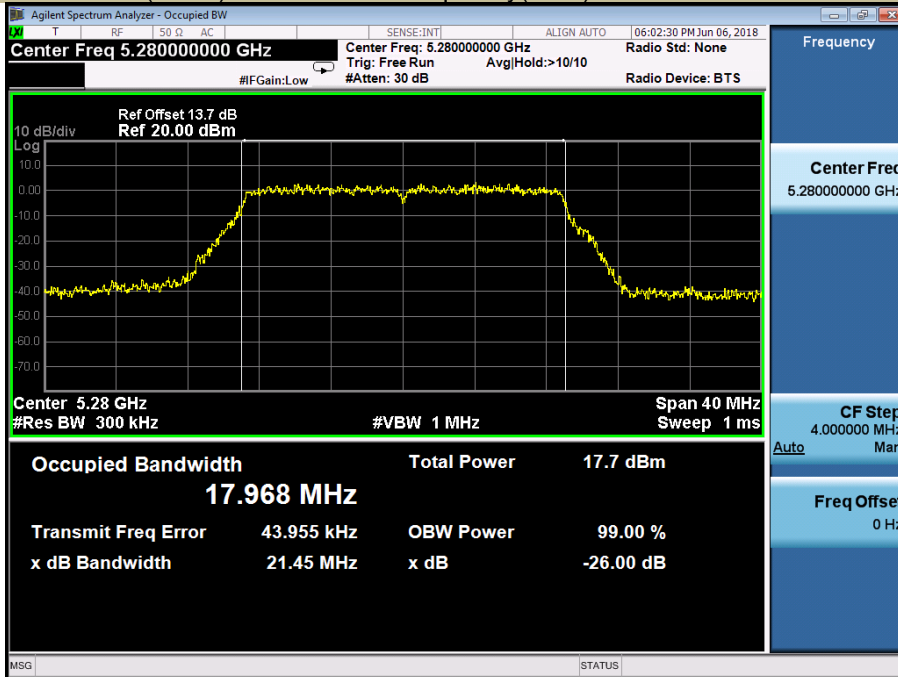

Emission Bandwidth&99% Occupied Bandwidth U-NII – 2A
 Test Model 802.11ac(HT20) Frequency(MHz) 5320

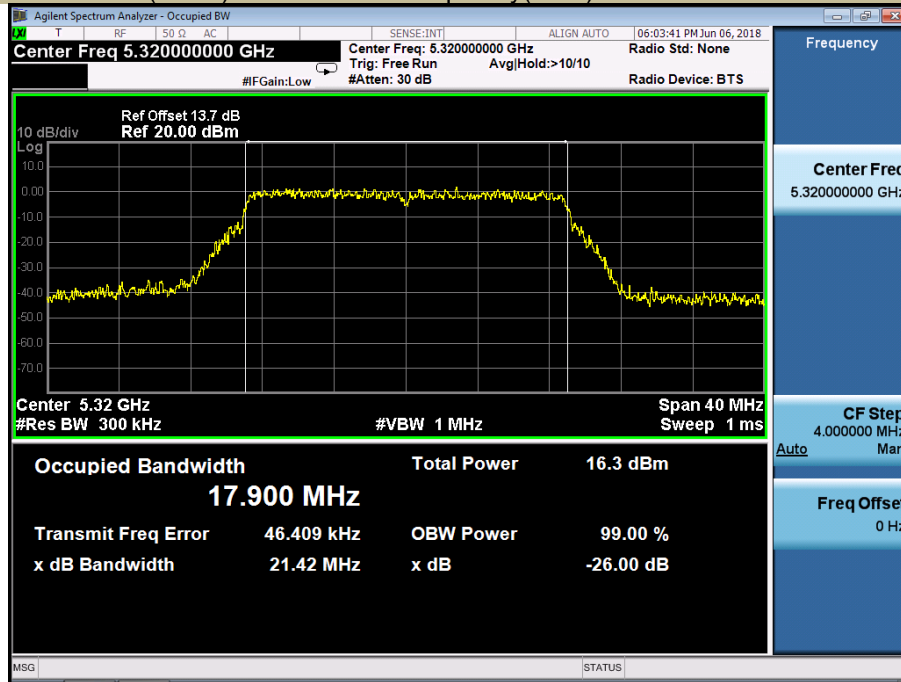

Emission Bandwidth&99% Occupied Bandwidth U-NII – 2A
 Test Model 802.11n-HT40 Frequency(MHz) 5270

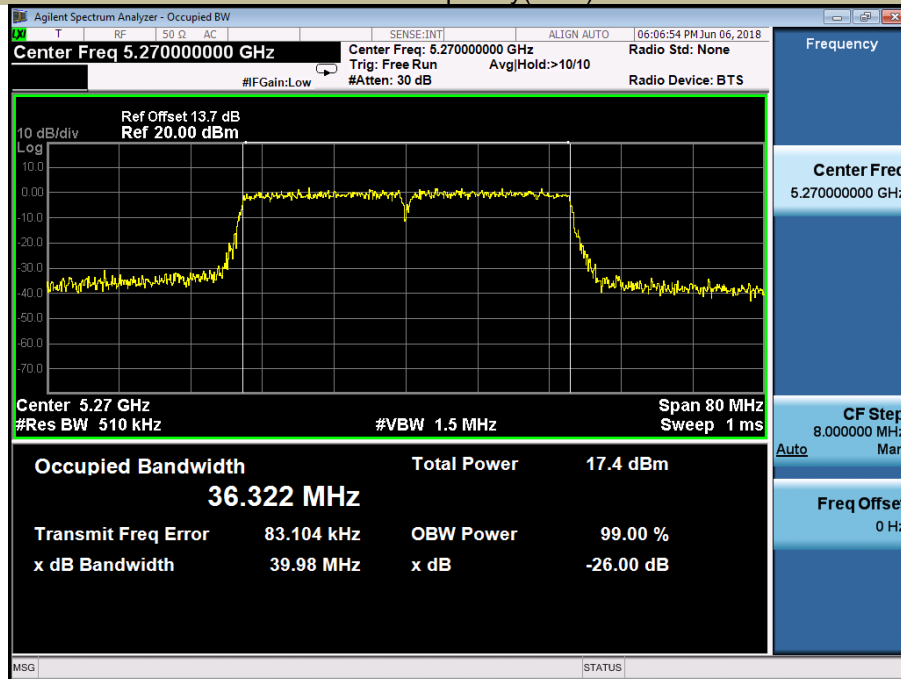

Emission Bandwidth & 99% Occupied Bandwidth U-NII – 2A
 Test Model 802.11n-HT40 Frequency(MHz) 5310

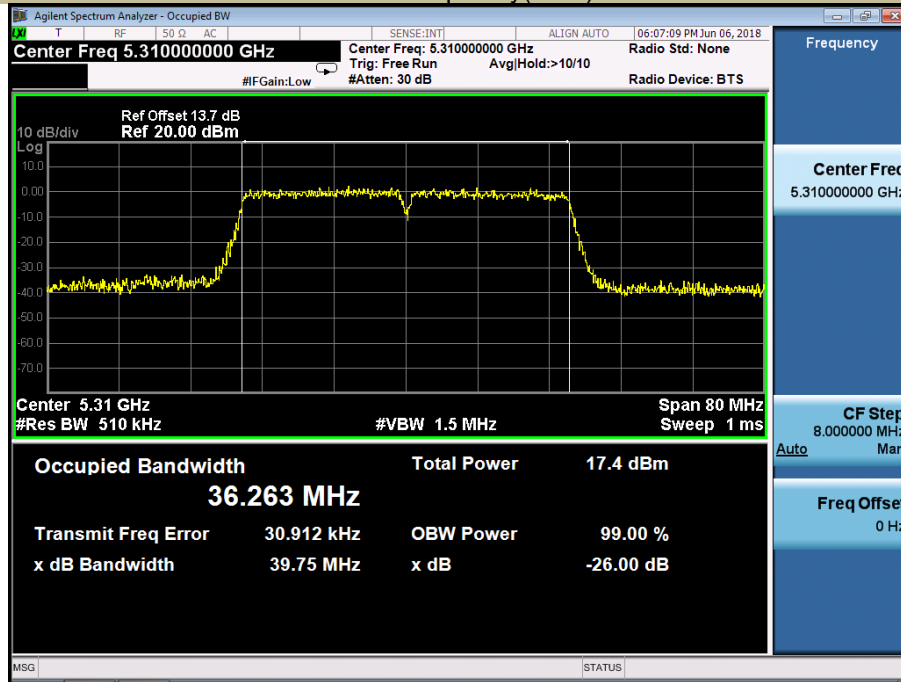

Emission Bandwidth & 99% Occupied Bandwidth U-NII – 2A
 Test Model 802.11ac(HT40) Frequency(MHz) 5270

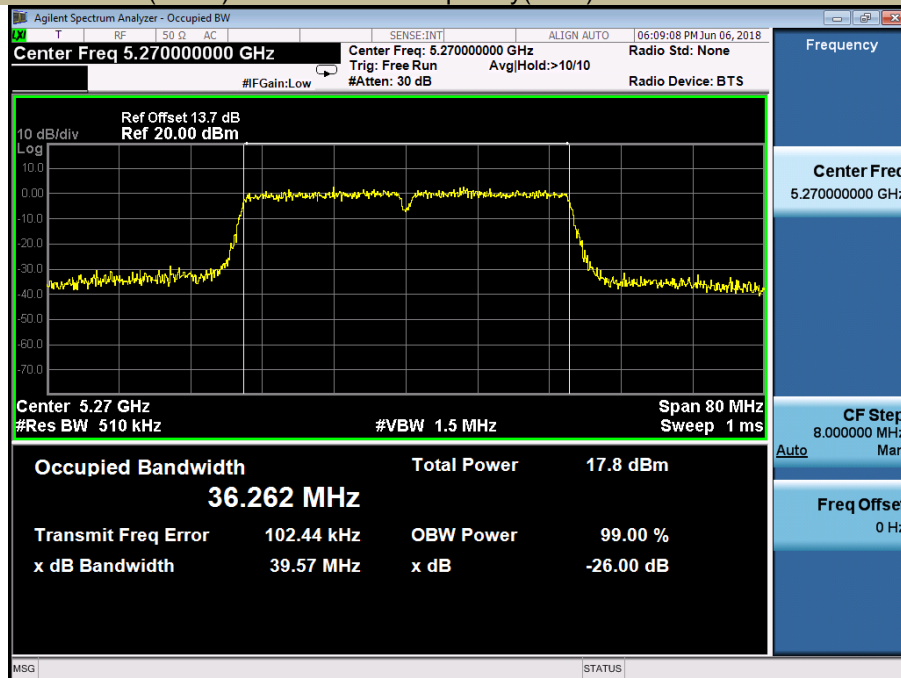

Emission Bandwidth&99% Occupied Bandwidth U-NII – 2A
 Test Model 802.11ac(HT40) Frequency(MHz) 5310

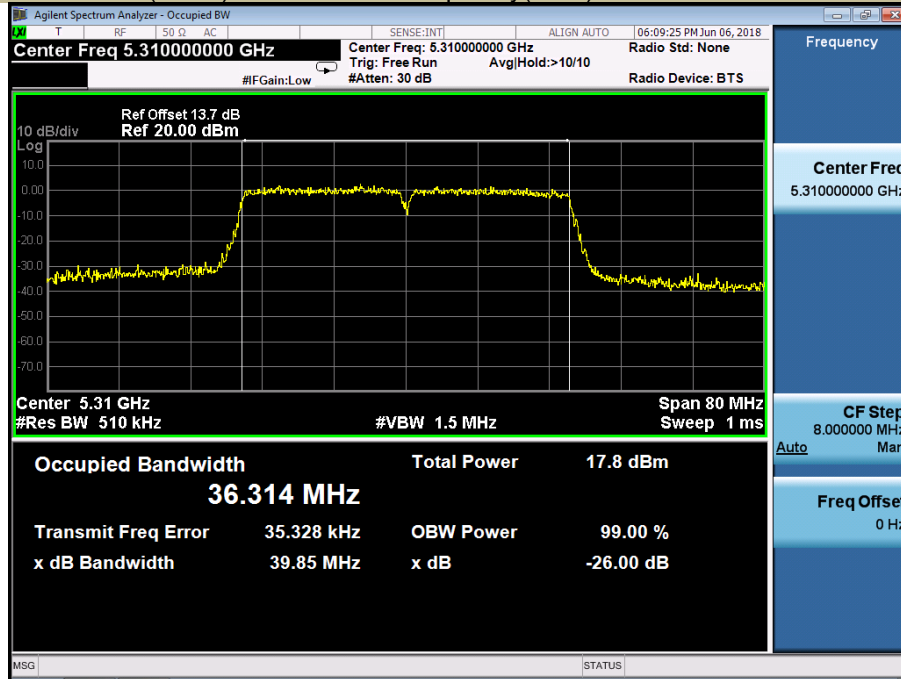

Emission Bandwidth&99% Occupied Bandwidth U-NII – 2A
 Test Model 802.11ac 80 Frequency(MHz) 5290

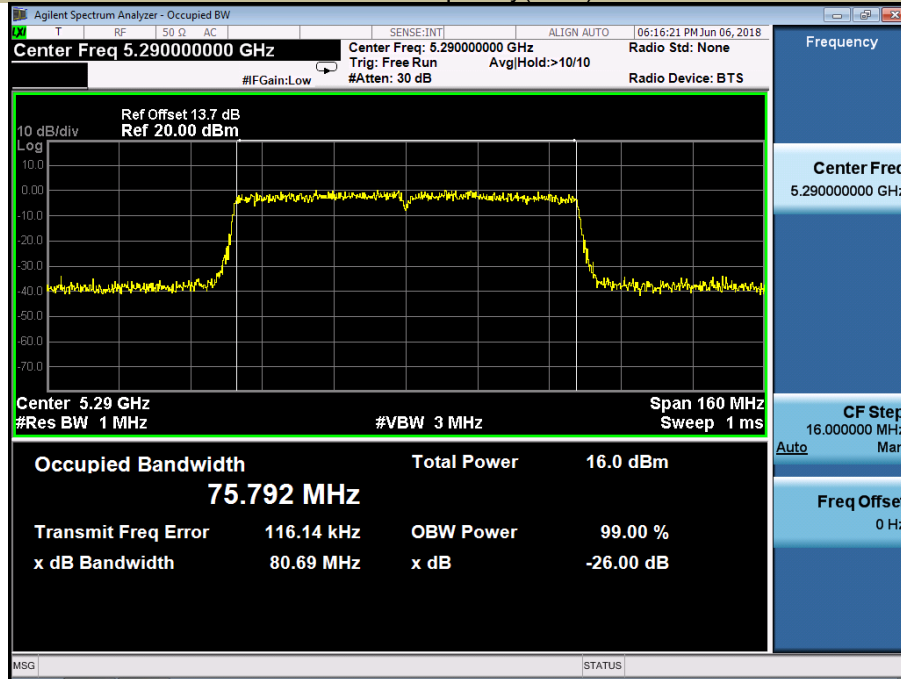

5470-5725MHz

Test Mode	Test Channel MHz		26 dB Bandwidth MHz	99% Bandwidth MHz	Verdict
802.11a	CH100	5500	21.00	16.849	Pass
	CH116	5580	21.56	16.866	Pass
	CH140	5700	21.16	16.843	Pass
802.11n-HT20	CH100	5500	21.63	17.920	Pass
	CH116	5580	21.60	17.977	Pass
	CH140	5700	21.46	17.870	Pass
802.11ac(VHT20)	CH100	5500	21.72	17.952	Pass
	CH116	5580	21.68	17.989	Pass
	CH140	5700	21.51	17.909	Pass
802.11n-HT40	CH102	5510	39.65	36.332	Pass
	CH110	5550	39.62	36.383	Pass
	CH134	5670	39.76	36.437	Pass
802.11ac(VHT40)	CH102	5510	40.09	36.333	Pass
	CH110	5550	40.04	36.333	Pass
	CH134	5670	39.67	36.415	Pass
802.11ac(VHT80)	CH106	5530	80.08	75.984	Pass

Emission Bandwidth&99% Occupied Bandwidth U-NII – 2C
 Test Model 802.11a Frequency(MHz) 5500

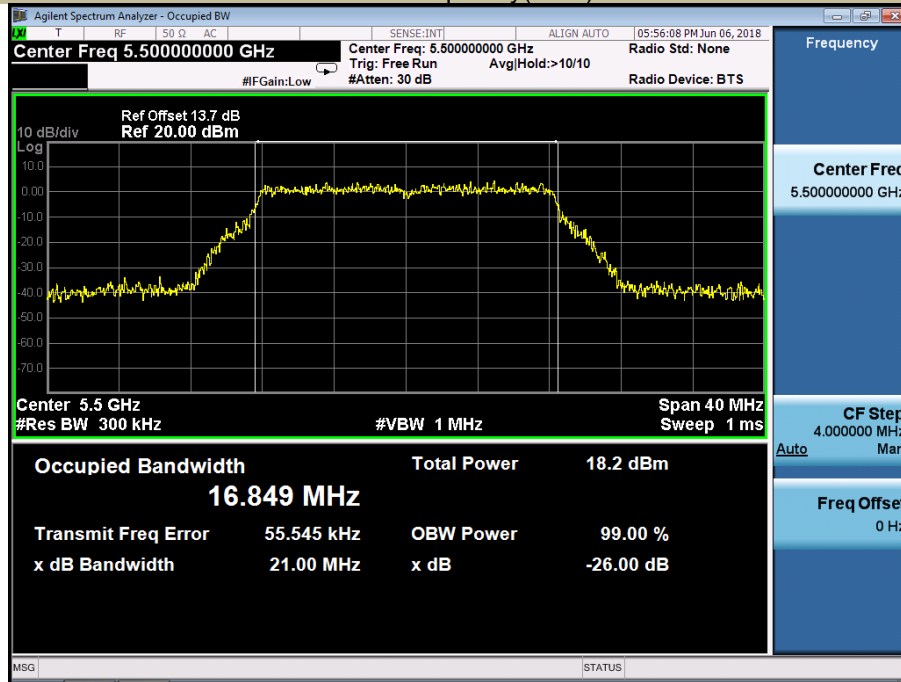

Emission Bandwidth&99% Occupied Bandwidth U-NII – 2C
 Test Model 802.11a Frequency(MHz) 5580

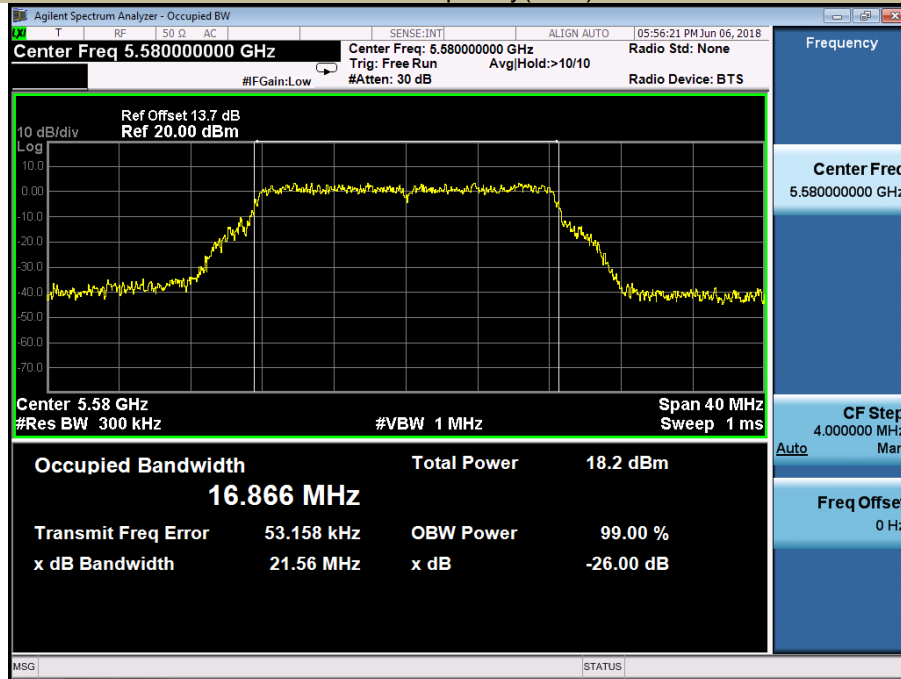

Emission Bandwidth&99% Occupied Bandwidth U-NII – 2C
 Test Model 802.11a Frequency(MHz) 5700

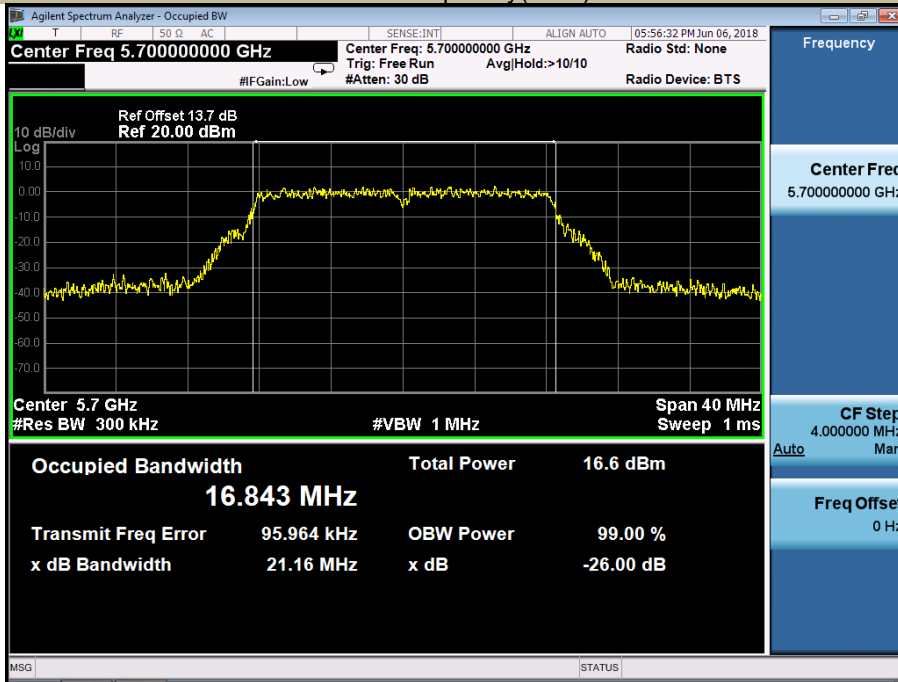

Emission Bandwidth&99% Occupied Bandwidth U-NII – 2C
 Test Model 802.11n-HT20 Frequency(MHz) 5500

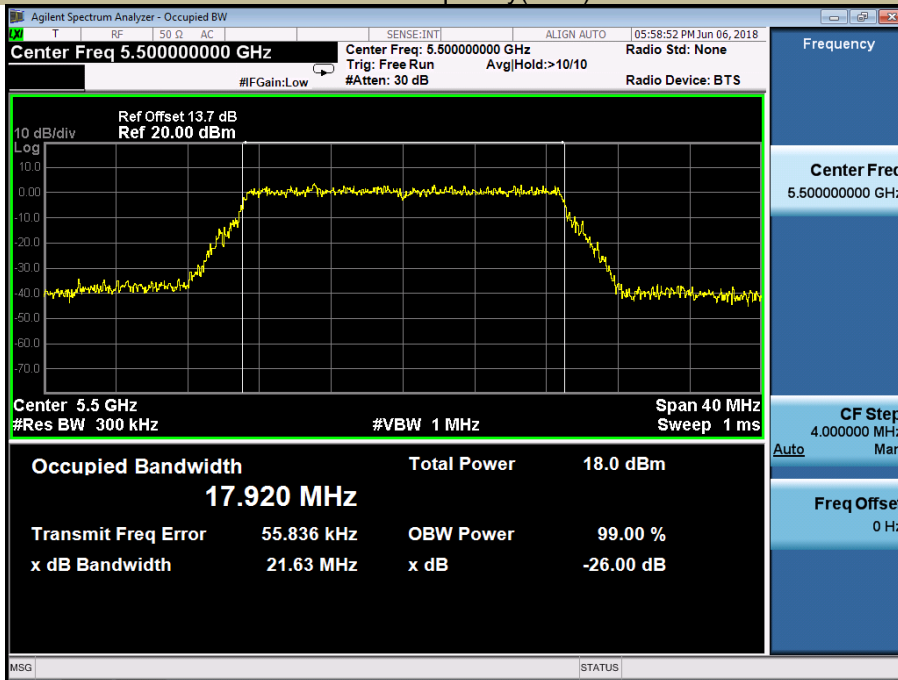

Emission Bandwidth&99% Occupied Bandwidth U-NII – 2C
 Test Model 802.11n-HT20 Frequency(MHz) 5580

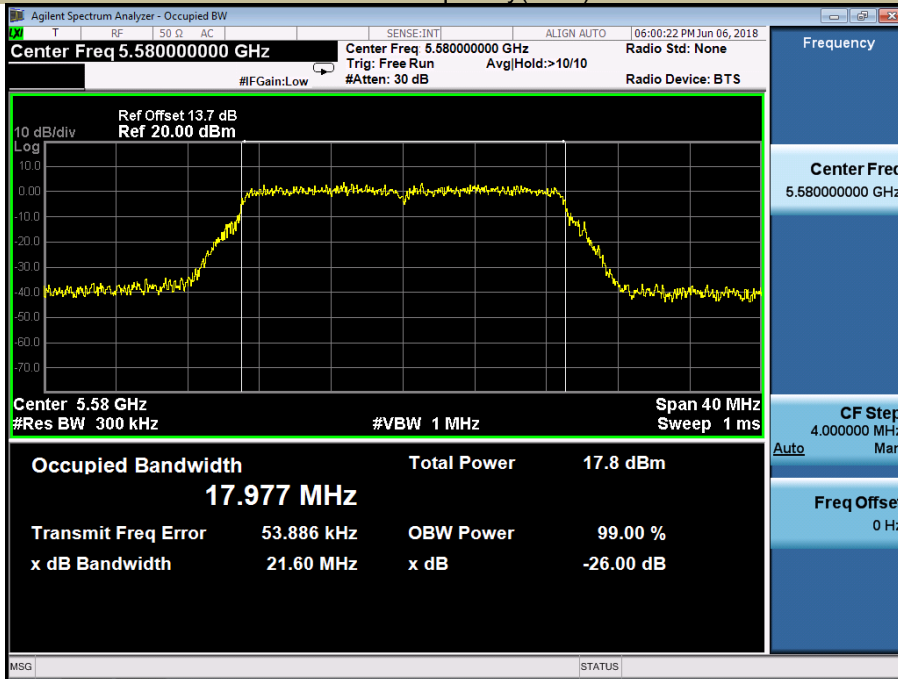

Emission Bandwidth&99% Occupied Bandwidth U-NII – 2C
 Test Model 802.11n-HT20 Frequency(MHz) 5700

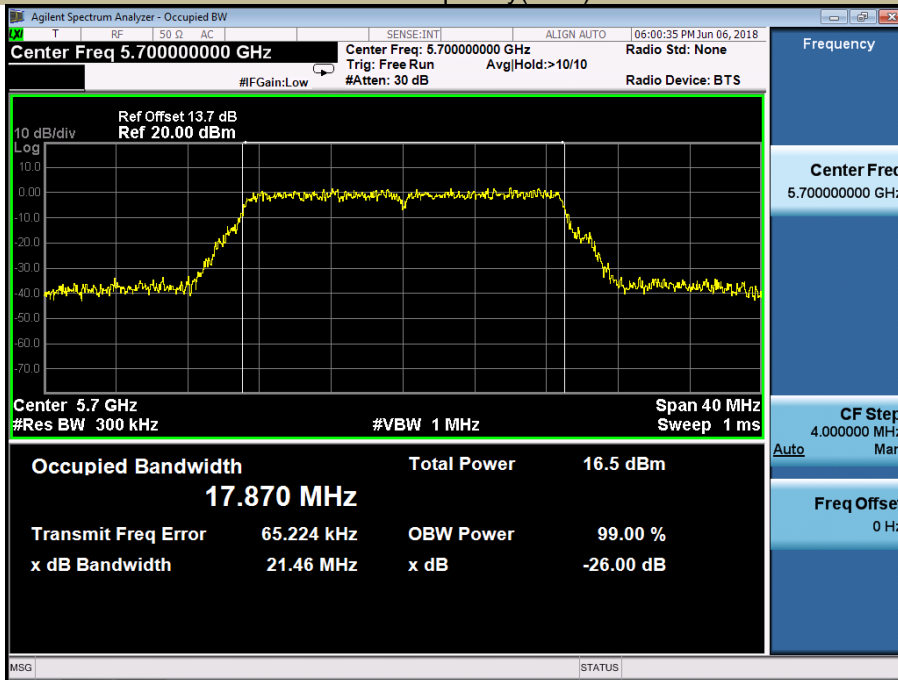

Emission Bandwidth&99% Occupied Bandwidth U-NII – 2C
 Test Model 802.11ac(HT20) Frequency(MHz) 5500

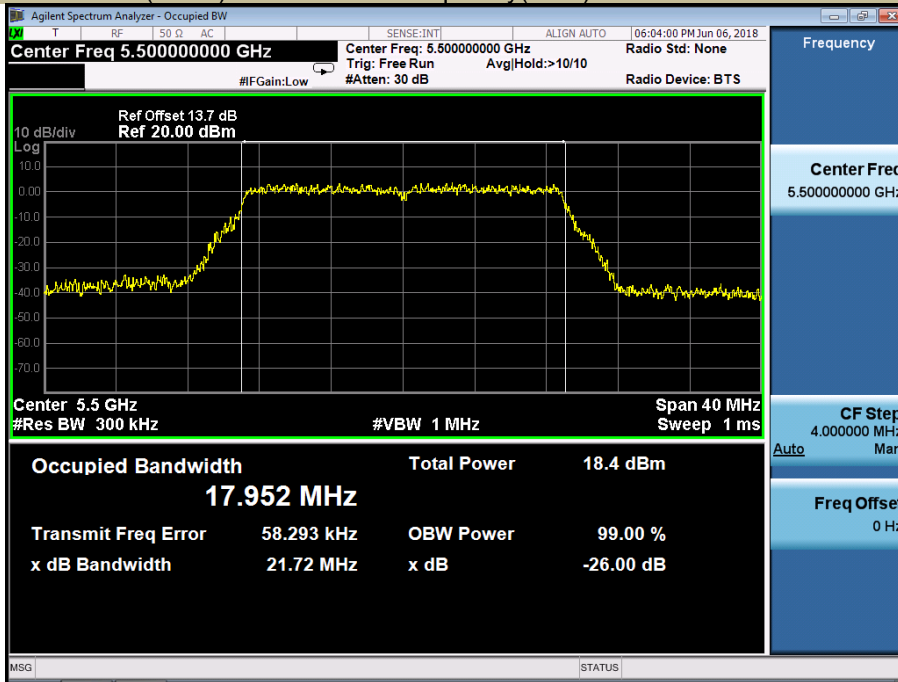

Emission Bandwidth&99% Occupied Bandwidth U-NII – 2C
 Test Model 802.11ac(HT20) Frequency(MHz) 5580

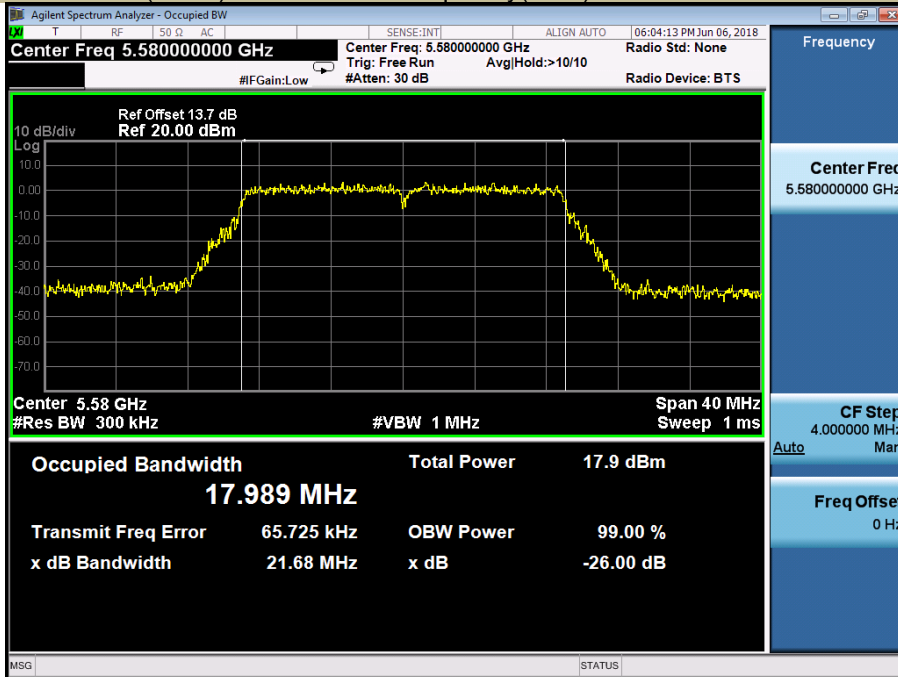

Emission Bandwidth&99% Occupied Bandwidth U-NII – 2C
 Test Model 802.11ac(HT20) Frequency(MHz) 5700

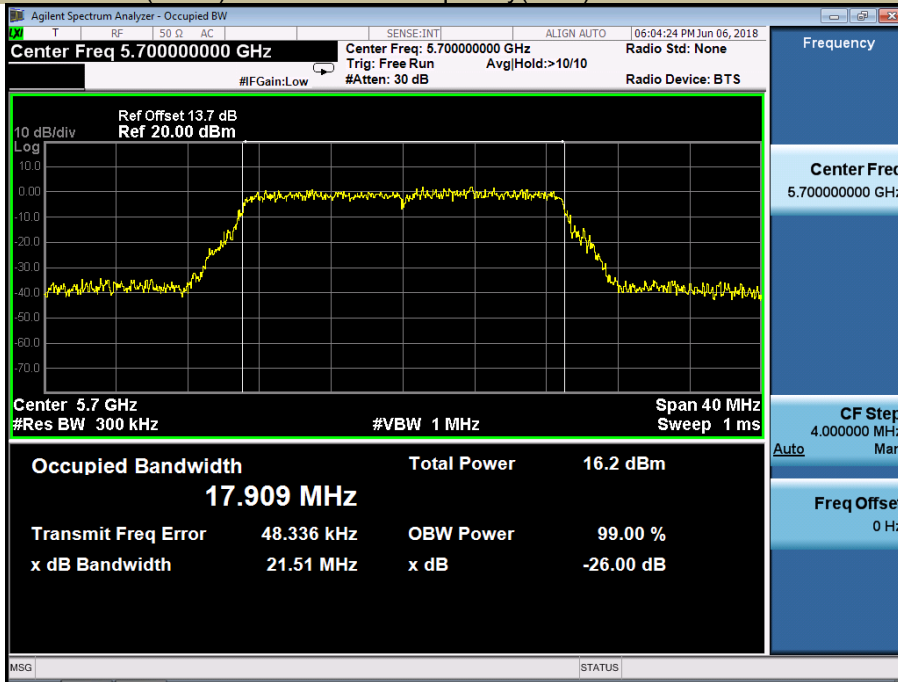

Emission Bandwidth&99% Occupied Bandwidth U-NII – 2C
 Test Model 802.11n-HT40 Frequency(MHz) 5510

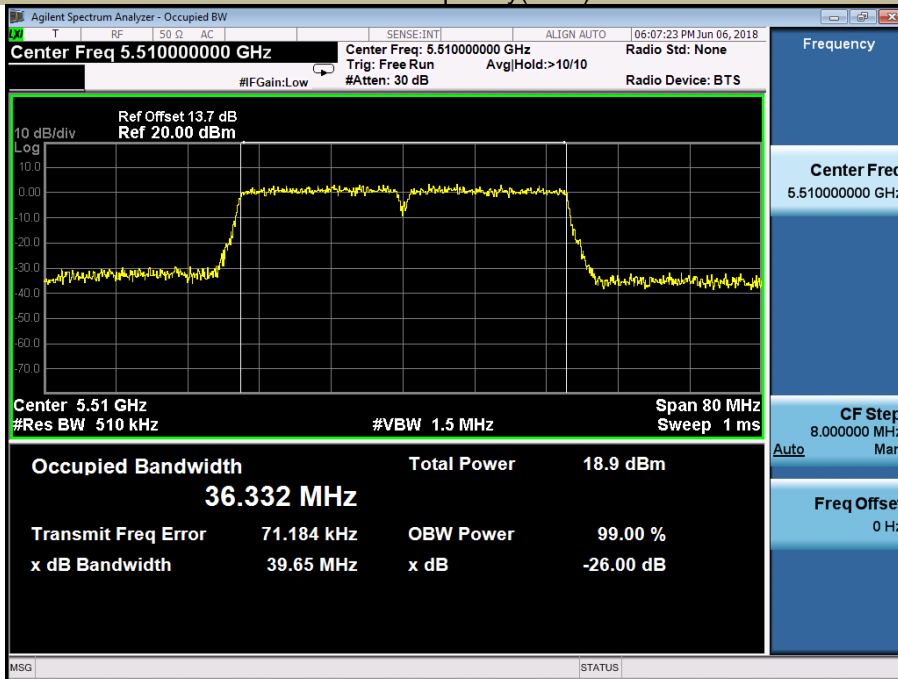

Emission Bandwidth&99% Occupied Bandwidth U-NII – 2C
 Test Model 802.11n-HT40 Frequency(MHz) 5550

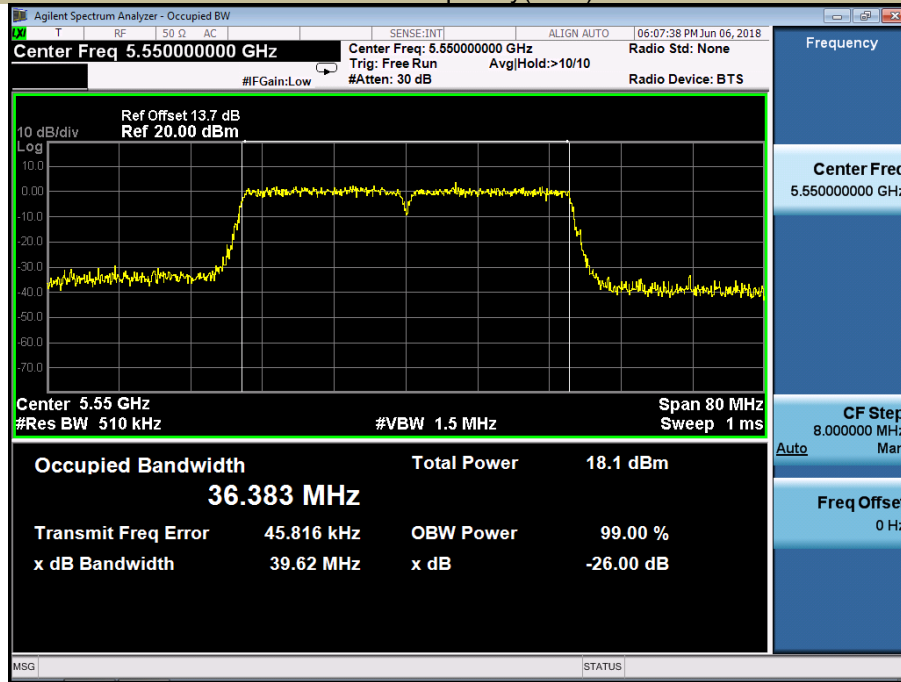

Emission Bandwidth&99% Occupied Bandwidth U-NII – 2C
 Test Model 802.11n-HT40 Frequency(MHz) 5670

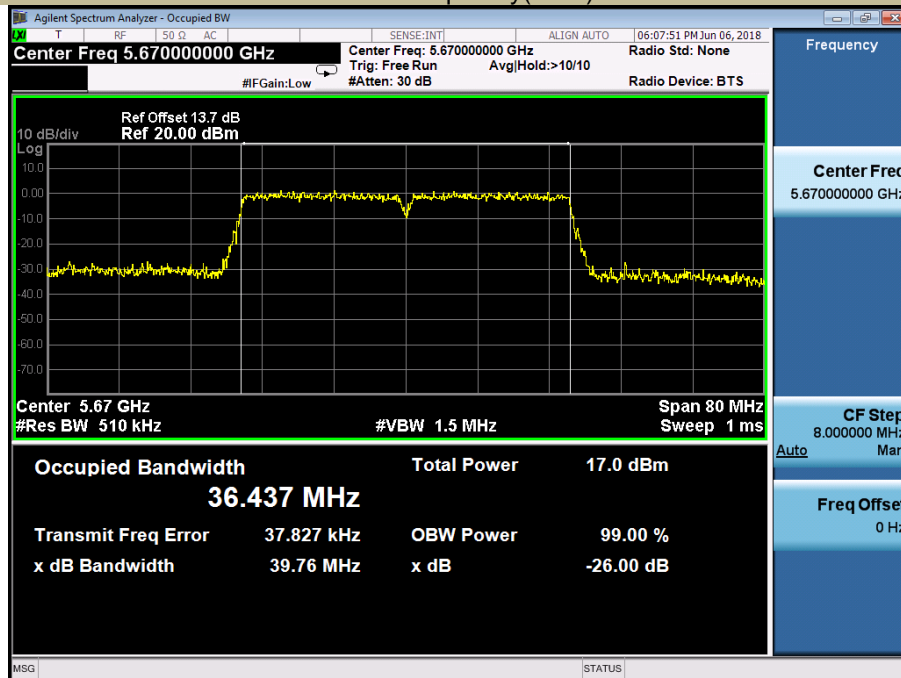

Emission Bandwidth&99% Occupied Bandwidth U-NII – 2C
 Test Model 802.11ac(HT40) Frequency(MHz) 5510

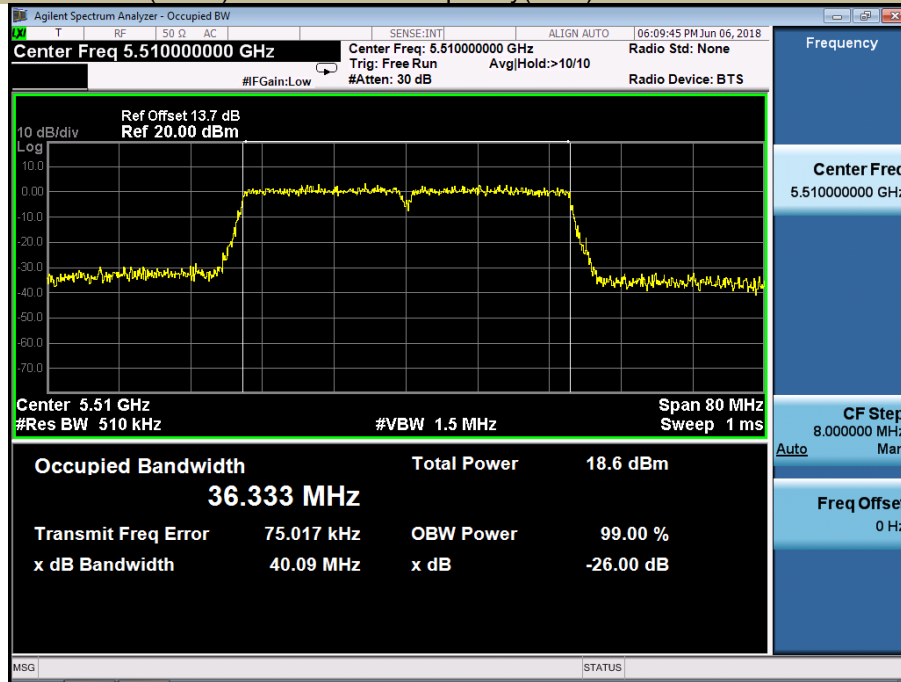

Emission Bandwidth&99% Occupied Bandwidth U-NII – 2C
 Test Model 802.11ac(HT40) Frequency(MHz) 5550

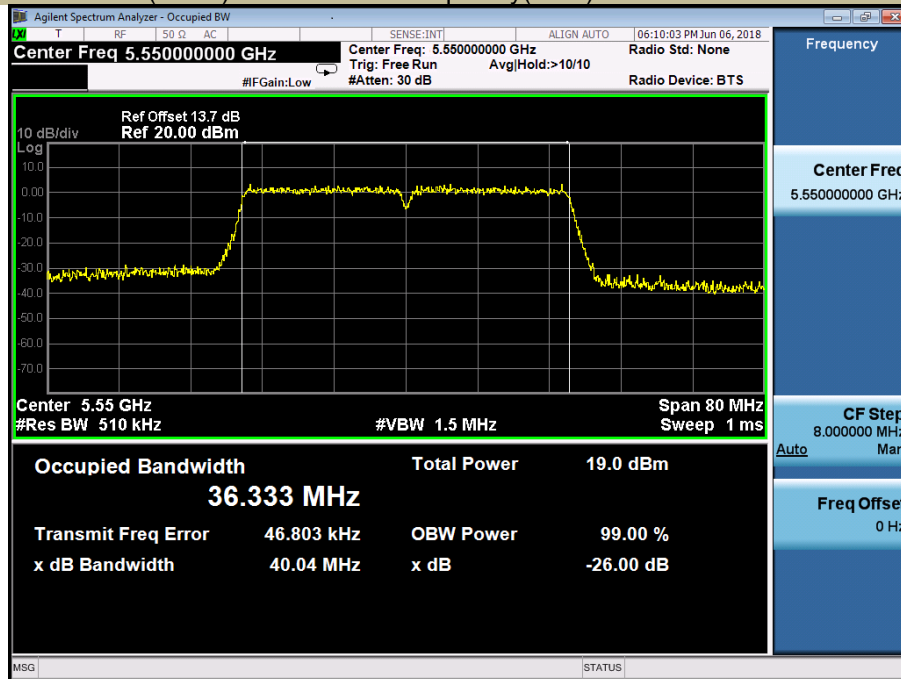

Emission Bandwidth & 99% Occupied Bandwidth U-NII – 2C
 Test Model 802.11ac(HT40) Frequency(MHz) 5670

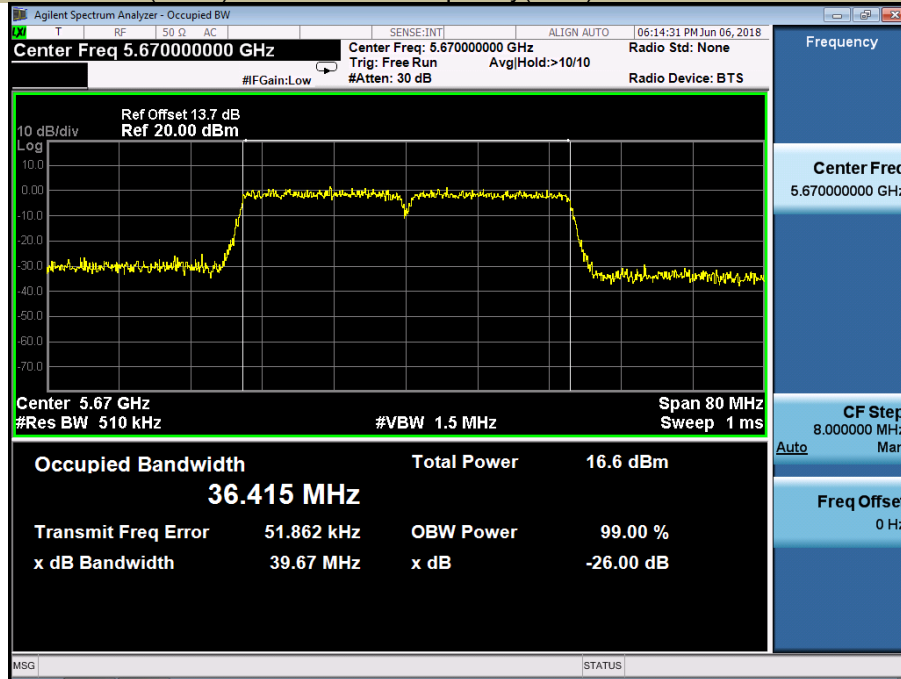

Emission Bandwidth & 99% Occupied Bandwidth U-NII – 2C
 Test Model 802.11ac 80 Frequency(MHz) 5530

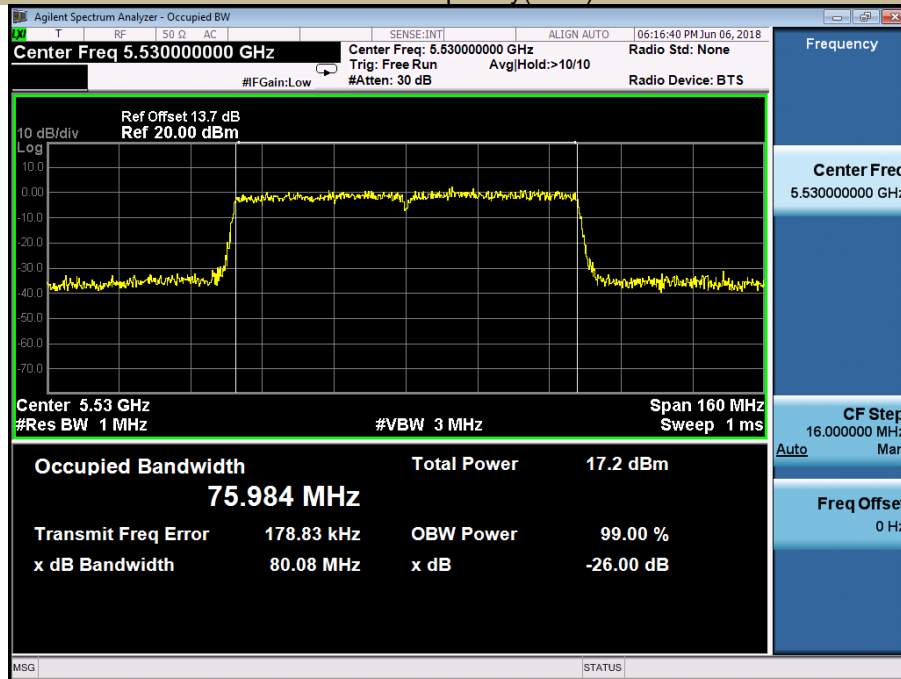

5725-5850MHz

Test Mode	Test Channel MHz		6 dB Bandwidth MHz	99% Bandwidth MHz	Limit kHz
802.11a	CH149	5745	16.29	16.530	≥500
	CH157	5785	16.39	16.536	≥500
	CH165	5825	16.38	16.518	≥500
802.11n-HT20	CH149	5745	17.57	17.692	≥500
	CH157	5785	17.61	17.704	≥500
	CH165	5825	17.60	17.726	≥500
802.11ac(VHT20)	CH149	5745	17.62	17.707	≥500
	CH157	5785	17.63	17.719	≥500
	CH165	5825	17.63	17.714	≥500
802.11n-HT40	CH151	5755	36.43	36.291	≥500
	CH159	5795	36.41	36.222	≥500
802.11ac(VHT40)	CH151	5755	35.93	36.235	≥500
	CH159	5795	35.79	36.176	≥500
802.11ac(VHT80)	CH155	5775	74.90	75.686	≥500

Emission Bandwidth&99% Occupied Bandwidth U-NII - 3
Test Model 802.11a Frequency(MHz) 5745

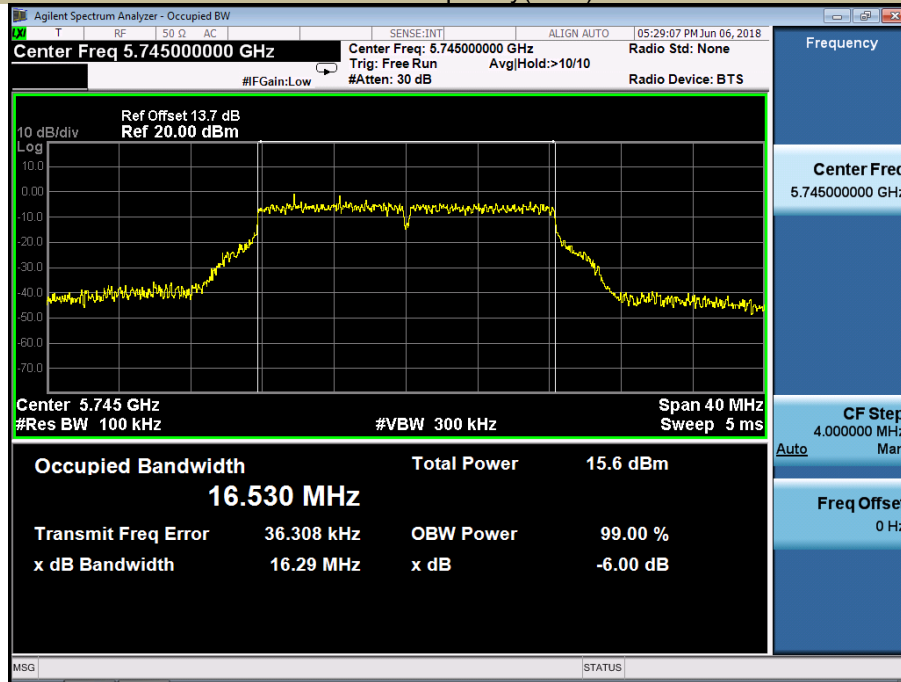

Emission Bandwidth&99% Occupied Bandwidth U-NII - 3
Test Model 802.11a Frequency(MHz) 5785

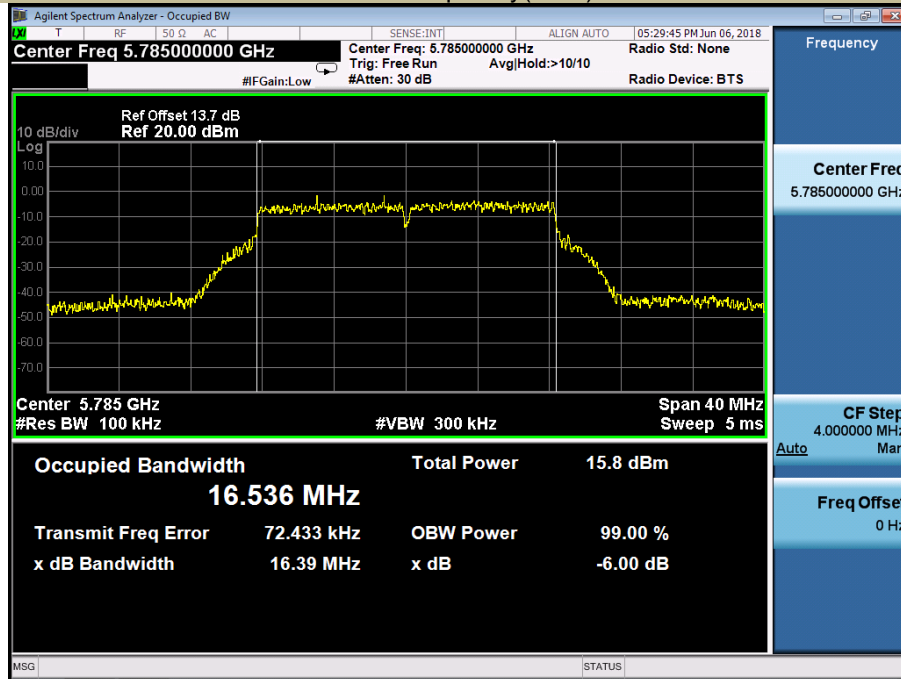

Emission Bandwidth&99% Occupied Bandwidth U-NII - 3
Test Model 802.11a Frequency(MHz) 5825

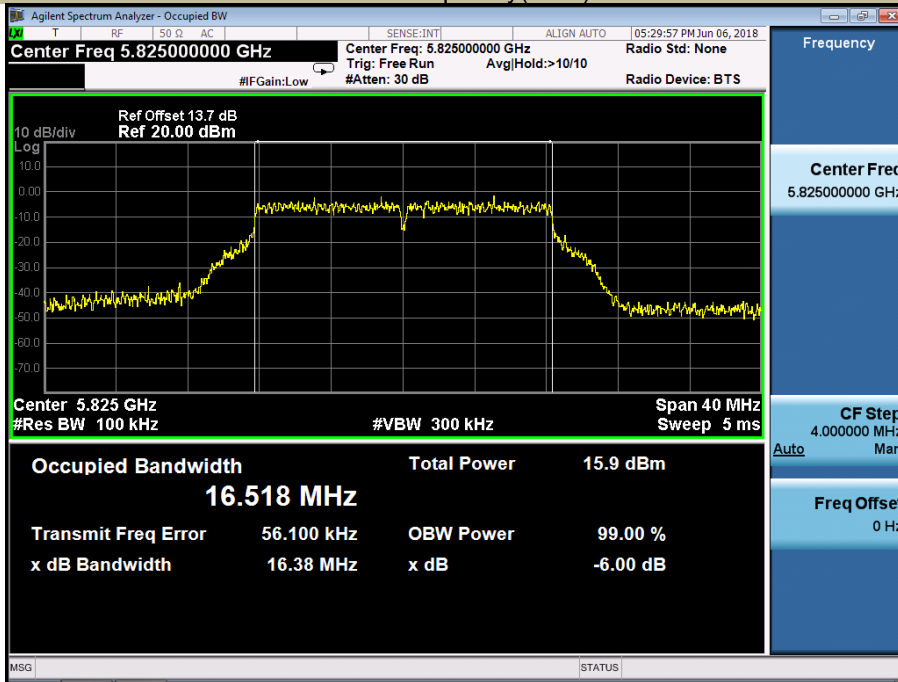

Emission Bandwidth&99% Occupied Bandwidth U-NII - 3
Test Model 802.11n-HT20 Frequency(MHz) 5745

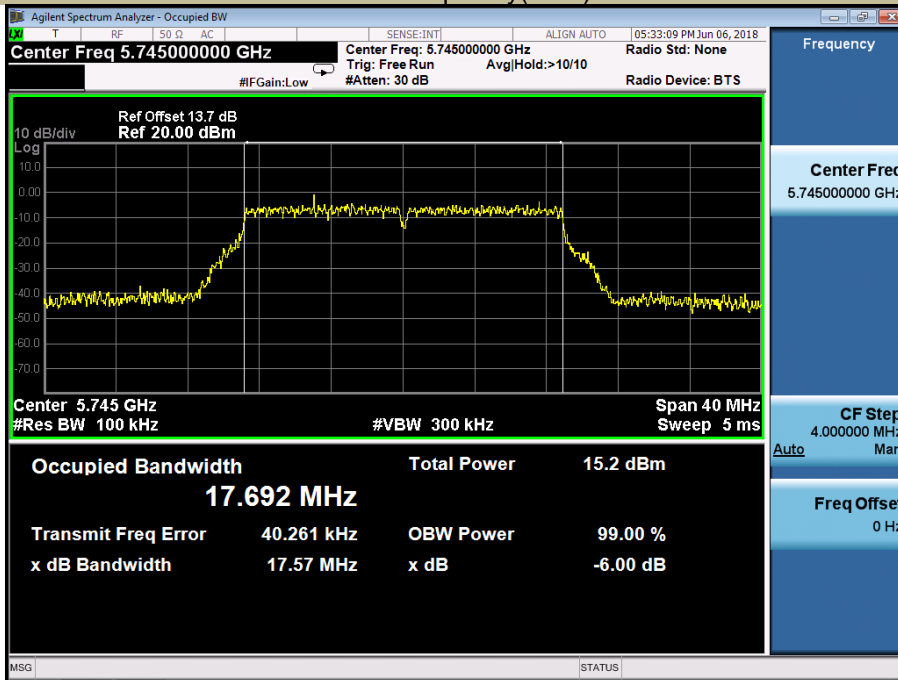

Emission Bandwidth&99% Occupied Bandwidth U-NII - 3
Test Model 802.11n-HT20 Frequency(MHz) 5785

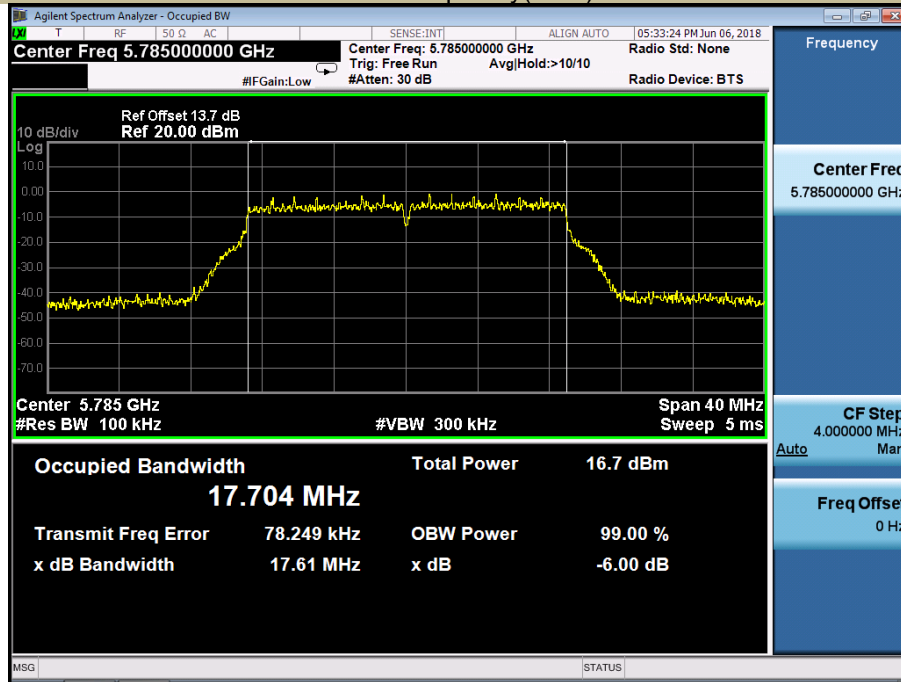

Emission Bandwidth&99% Occupied Bandwidth U-NII - 3
Test Model 802.11n-HT20 Frequency(MHz) 5825

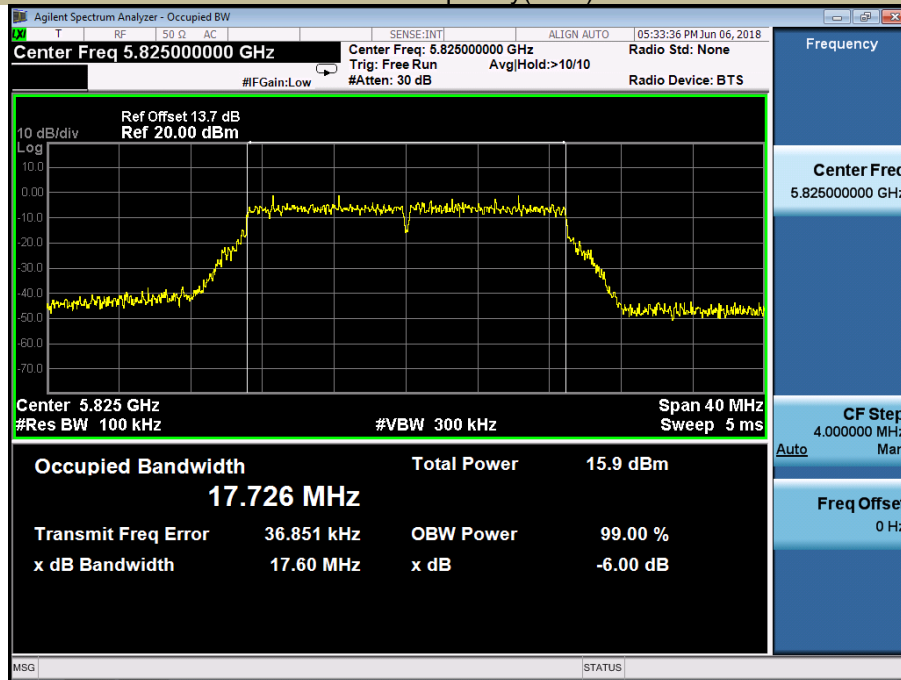

Emission Bandwidth&99% Occupied Bandwidth U-NII - 3
Test Model 802.11ac(HT20) Frequency(MHz) 5745

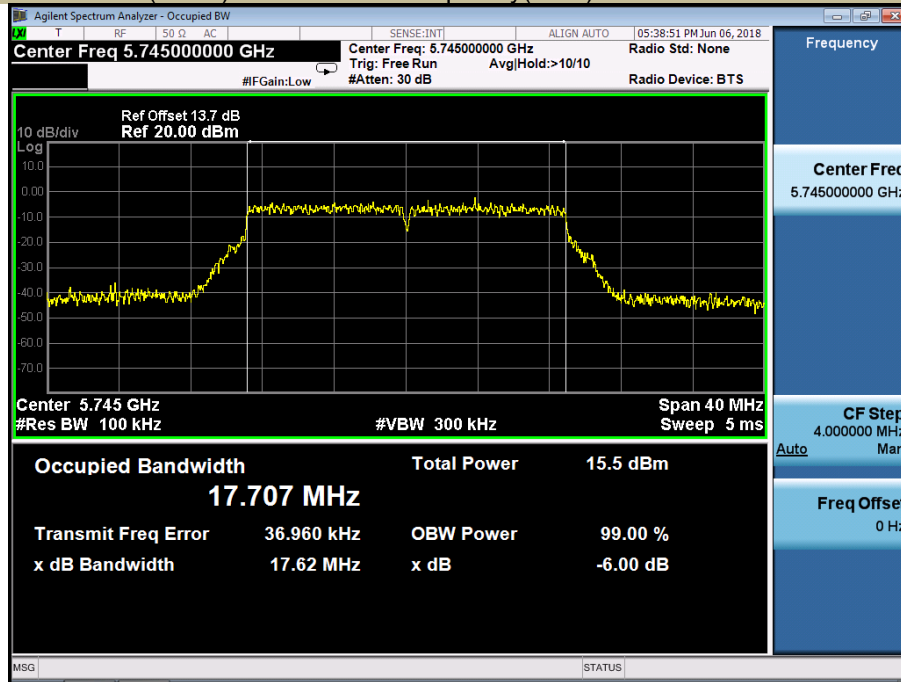

Emission Bandwidth&99% Occupied Bandwidth U-NII - 3
Test Model 802.11ac(HT20) Frequency(MHz) 5785

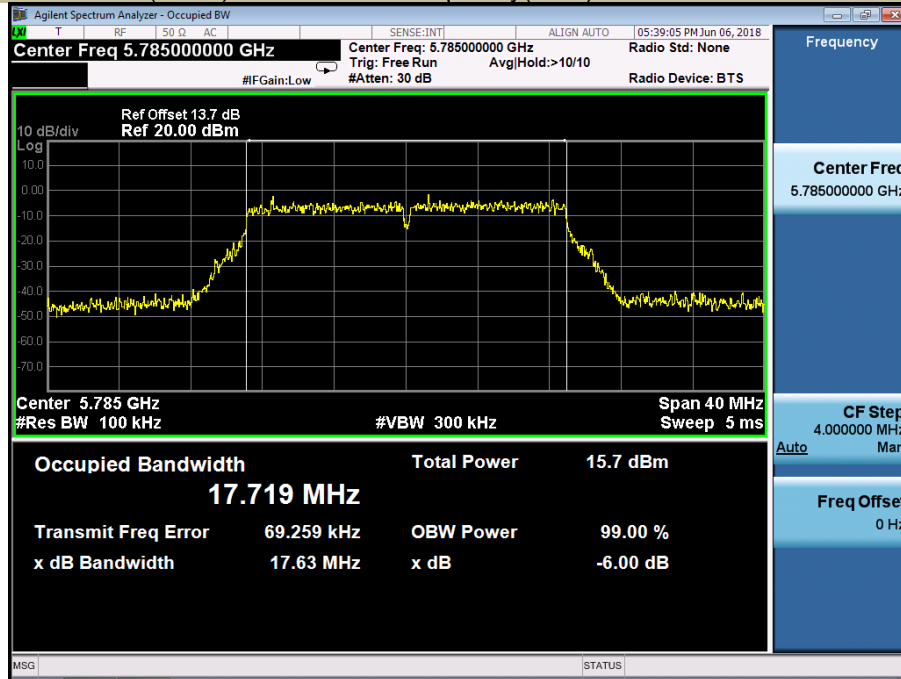

Emission Bandwidth & 99% Occupied Bandwidth U-NII - 3
 Test Model 802.11ac(HT20) Frequency(MHz) 5825

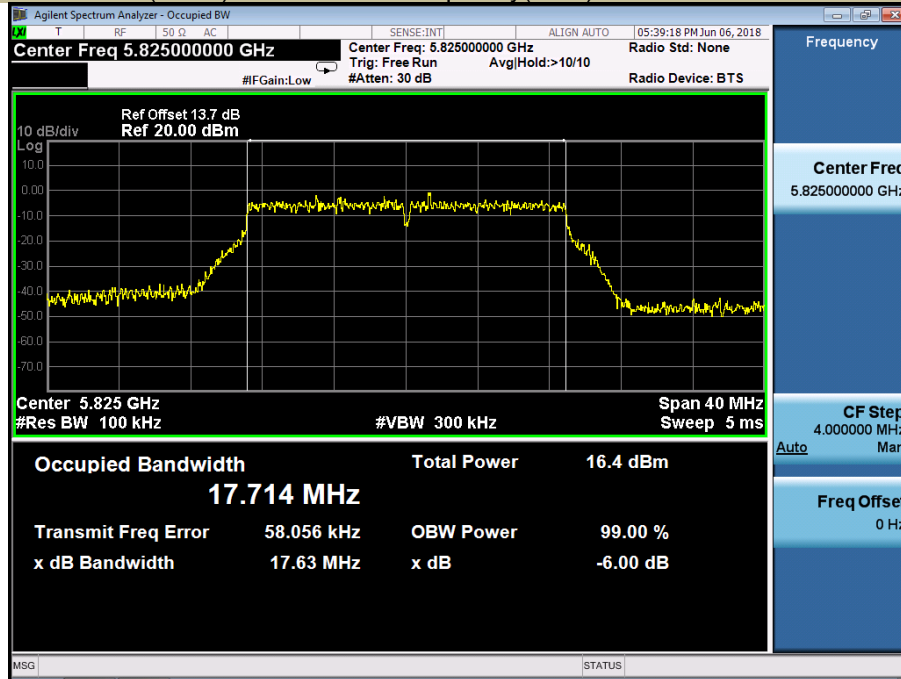

Emission Bandwidth & 99% Occupied Bandwidth U-NII - 3
 Test Model 802.11n-HT40 Frequency(MHz) 5755

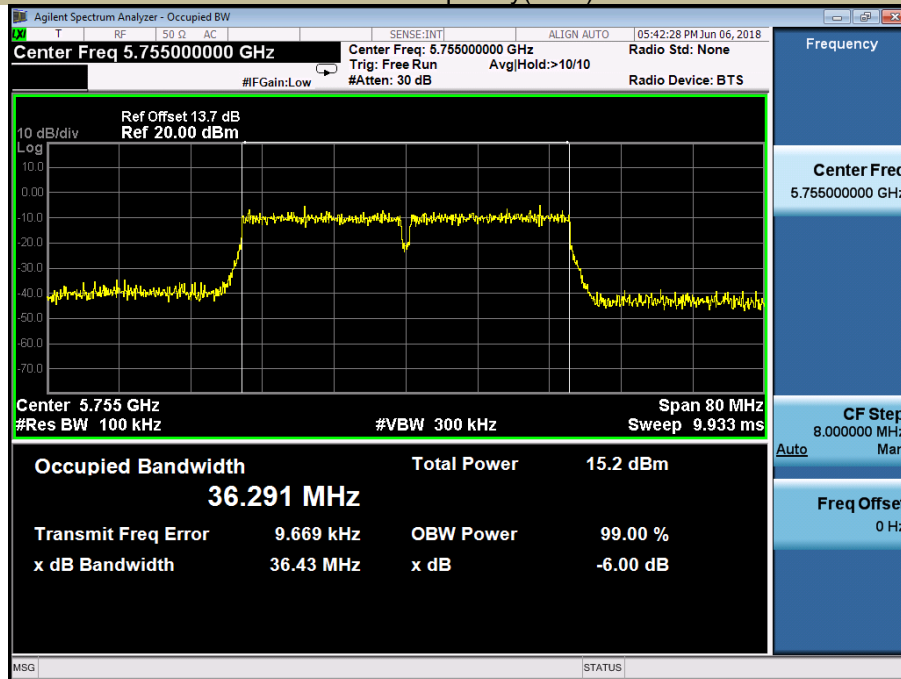

Emission Bandwidth & 99% Occupied Bandwidth U-NII - 3
 Test Model 802.11n-HT40 Frequency(MHz) 5795

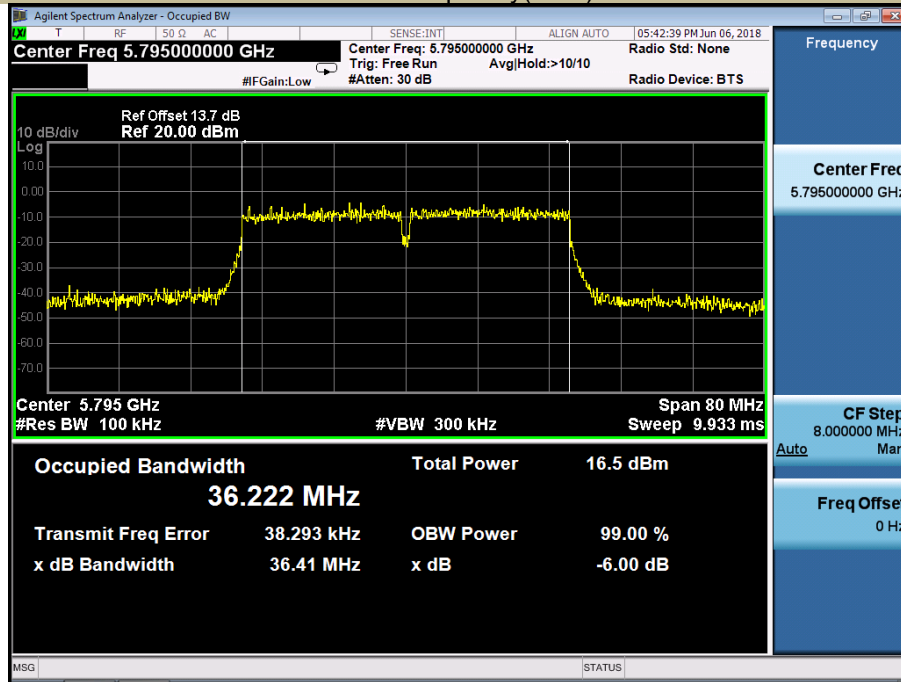

Emission Bandwidth & 99% Occupied Bandwidth U-NII - 3
 Test Model 802.11ac(HT40) Frequency(MHz) 5755

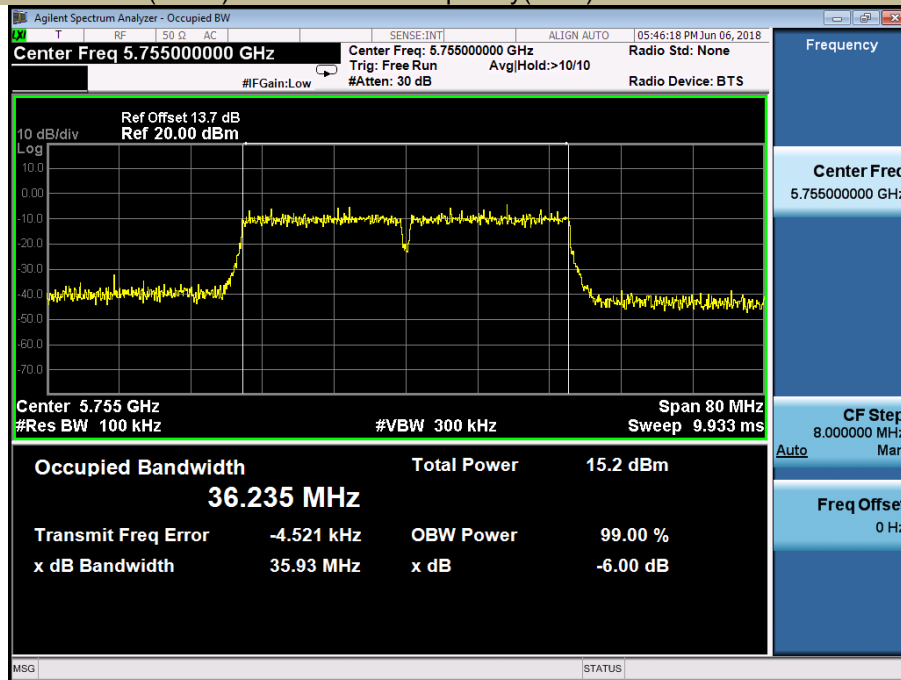

Emission Bandwidth & 99% Occupied Bandwidth U-NII - 3
 Test Model 802.11ac(HT40) Frequency(MHz) 5795

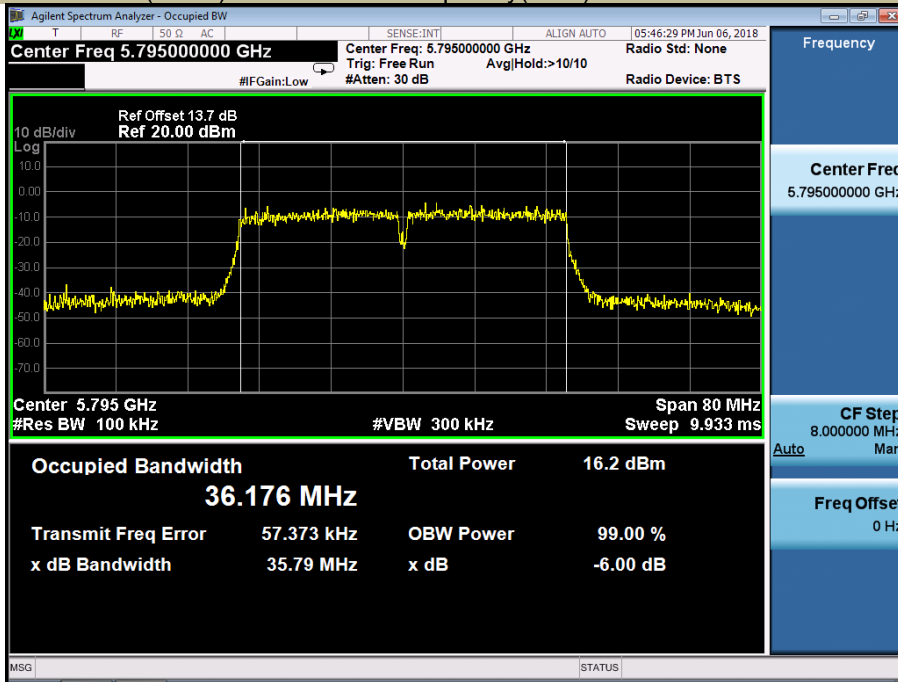

Emission Bandwidth & 99% Occupied Bandwidth U-NII - 3
 Test Model 802.11ac 80 Frequency(MHz) 5775

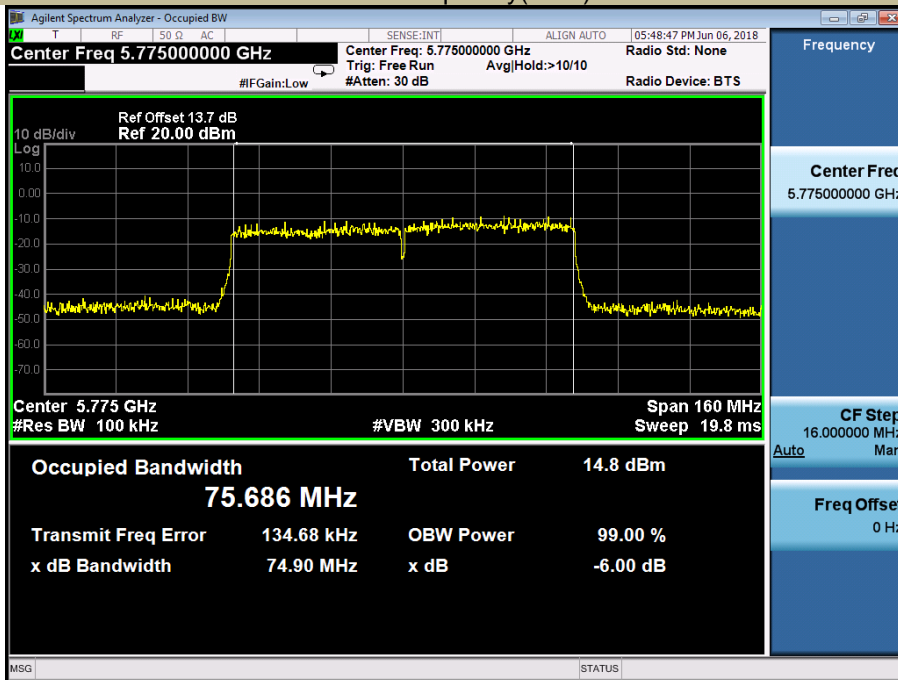

8.2 MAXIMUM CONDUCTED OUTPUT POWER

8.2.1 Applicable Standard

According to FCC Part 15.407(a)(1) for UNII Band I
According to FCC Part 15.407(a)(2) for UNII Band II-A and UNII Band II-C
According to FCC Part 15.407(a)(3) for UNII Band III
According to 789033 D02 Section II(E)

8.2.2 Conformance Limit

■ For the band 5.15-5.25 GHz,

(a) (1) (i) For an outdoor access point operating in the band 5.15-5.25 GHz, the maximum conducted output power over the frequency band of operation shall not exceed 1 W provided the maximum antenna gain does not exceed 6 dBi. If transmitting antennas of directional gain greater than 6 dBi are used, both the maximum conducted output power and the maximum power spectral density shall be reduced by the amount in dB that the directional gain of the antenna exceeds 6 dBi. The maximum e.i.r.p. at any elevation angle above 30 degrees as measured from the horizon must not exceed 125 mW (21 dBm).

(a) (1) (ii) For an indoor access point operating in the band 5.15-5.25 GHz, the maximum conducted output power over the frequency band of operation shall not exceed 1 W provided the maximum antenna gain does not exceed 6 dBi. If transmitting antennas of directional gain greater than 6 dBi are used, both the maximum conducted output power and the maximum power spectral density shall be reduced by the amount in dB that the directional gain of the antenna exceeds 6 dBi.

(a) (1) (iii) For fixed point-to-point access points operating in the band 5.15-5.25 GHz, the maximum conducted output power over the frequency band of operation shall not exceed 1 W. Fixed point-to-point U-NII devices may employ antennas with directional gain up to 23 dBi without any corresponding reduction in the maximum conducted output power or maximum power spectral density. For fixed point-to-point transmitters that employ a directional antenna gain greater than 23 dBi, a 1 dB reduction in maximum conducted output power and maximum power spectral density is required for each 1 dB of antenna gain in excess of 23 dBi. Fixed, point-to-point operations exclude the use of point-to-multipoint systems, omnidirectional applications, and multiple collocated transmitters transmitting the same information. The operator of the U-NII device, or if the equipment is professionally installed, the installer, is responsible for ensuring that systems employing high gain directional antennas are used exclusively for fixed, point-to-point operations.

(a) (1) (iv) For mobile and portable client devices in the 5.15-5.25 GHz band, the maximum conducted output power over the frequency band of operation shall not exceed 250 mW provided the maximum antenna gain does not exceed 6 dBi. If transmitting antennas of directional gain greater than 6 dBi are used, both the maximum conducted output power and the maximum power spectral density shall be reduced by the amount in dB that the directional gain of the antenna exceeds 6 dBi.

■ For the 5.25-5.35 GHz and 5.47-5.725 GHz bands

(a) (2) the maximum conducted output power over the frequency bands of operation shall not exceed the lesser of 250 mW or $11 \text{ dBm} + 10 \log B$, where B is the 26 dB emission bandwidth in megahertz. In addition, the maximum power spectral density shall not exceed 11 dBm in any 1 megahertz band. If transmitting antennas of directional gain greater than 6 dBi are used, both the maximum conducted output power and the maximum power spectral density shall be reduced by the amount in dB that the directional gain of the antenna exceeds 6 dBi.

■ For the band 5.725-5.85 GHz

(a) (3) For the band 5.725-5.85 GHz, the maximum conducted output power over the frequency band of operation shall not exceed 1 W. In addition, the maximum power spectral density shall not exceed 30 dBm in any 500-kHz band. If transmitting antennas of directional gain greater than 6 dBi are used, both the maximum conducted output power and the maximum power spectral density shall be reduced by the amount in dB that the directional gain of the antenna exceeds 6 dBi.

8.2.3 Test Configuration

Test according to clause 6.1 radio frequency test setup

8.2.4 Test Procedure

The maximum average conducted output power can be measured using Method PM-G (Measurement using

a gated RF average power meter):

Measurements may be performed using a wideband gated RF power meter provided that the gate parameters are adjusted such that the power is measured only when the EUT is transmitting at its maximum power control level. Since the measurement is made only during the ON time of the transmitter, no duty cycle correction factor is required.

- a. The Transmitter output (antenna port) was connected to the power meter.
- b. Turn on the EUT and power meter and then record the power value.
- c. Repeat above procedures on all channels needed to be tested.

8.2.5 Test Results

1T1R - Antenna A

802.11a mode

Band	Channel Number	Channel Freq. (MHz)	Conducted Output Power(dBm)	Limit (dBm)	Verdict
U-NII - 1	CH36	5180	15.43	30	Pass
	CH40	5200	15.64	30	Pass
	CH48	5240	15.56	30	Pass

802.11n-HT20

Band	Channel Number	Channel Freq. (MHz)	Conducted Output Power(dBm)	Limit (dBm)	Verdict
U-NII - 1	CH36	5180	15.21	30	Pass
	CH40	5200	15.23	30	Pass
	CH48	5240	15.01	30	Pass

802.11 ac (VHT20)

Band	Channel Number	Channel Freq. (MHz)	Conducted Output Power(dBm)	Limit (dBm)	Verdict
U-NII - 1	CH36	5180	15.22	30	Pass
	CH40	5200	15.07	30	Pass
	CH48	5240	15.44	30	Pass

802.11n-HT40

Band	Channel Number	Channel Freq. (MHz)	Conducted Output Power(dBm)	Limit (dBm)	Verdict
U-NII - 1	CH38	5190	15.46	30	Pass
	CH46	5230	15.89	30	Pass

802.11 ac (VHT40)

Band	Channel Number	Channel Freq. (MHz)	Conducted Output Power(dBm)	Limit (dBm)	Verdict
U-NII - 1	CH38	5190	15.73	30	Pass
	CH46	5230	15.43	30	Pass

802.11 ac (VHT80)

Band	Channel Number	Channel Freq. (MHz)	Conducted Output Power(dBm)	Limit (dBm)	Verdict
U-NII - 1	CH42	5210	15.36	30	Pass

☒ 802.11a mode

Band	Channel Number	Channel Freq. (MHz)	Conducted Output Power(dBm)	Limit (dBm)	Verdict
U-NII – 2A	CH52	5260	15.91	24	Pass
	CH56	5280	15.83	24	Pass
	CH64	5320	15.29	24	Pass

☒ 802.11n-HT20

Band	Channel Number	Channel Freq. (MHz)	Conducted Output Power(dBm)	Limit (dBm)	Verdict
U-NII – 2A	CH52	5260	15.03	24	Pass
	CH56	5280	15.22	24	Pass
	CH64	5320	15.02	24	Pass

☒ 802.11 ac (VHT20)

Band	Channel Number	Channel Freq. (MHz)	Conducted Output Power(dBm)	Limit (dBm)	Verdict
U-NII – 2A	CH52	5260	15.89	24	Pass
	CH56	5280	15.95	24	Pass
	CH64	5320	15.58	24	Pass

☒ 802.11n-HT40

Band	Channel Number	Channel Freq. (MHz)	Conducted Output Power(dBm)	Limit (dBm)	Verdict
U-NII – 2A	CH54	5270	15.29	24	Pass
	CH62	5310	15.43	24	Pass

☒ 802.11 ac (VHT40)

Band	Channel Number	Channel Freq. (MHz)	Conducted Output Power(dBm)	Limit (dBm)	Verdict
U-NII – 2A	CH54	5270	15.49	24	Pass
	CH62	5310	15.54	24	Pass

☒ 802.11 ac (VHT80)

Band	Channel Number	Channel Freq. (MHz)	Conducted Output Power(dBm)	Limit (dBm)	Verdict
U-NII – 2A	CH58	5290	15.21	24	Pass

☒ 802.11a mode

Band	Channel Number	Channel Freq. (MHz)	Conducted Output Power(dBm)	Limit (dBm)	Verdict
U-NII – 2C	CH100	5500	15.24	24	Pass
	CH116	5580	15.95	24	Pass
	CH140	5700	15.58	24	Pass

☒ 802.11n-HT20

Band	Channel Number	Channel Freq. (MHz)	Conducted Output Power(dBm)	Limit (dBm)	Verdict
U-NII – 2C	CH100	5500	15.69	24	Pass
	CH116	5580	15.51	24	Pass
	CH140	5700	15.78	24	Pass

☒ 802.11 ac (VHT20)

Band	Channel Number	Channel Freq. (MHz)	Conducted Output Power(dBm)	Limit (dBm)	Verdict
U-NII – 2C	CH100	5500	15.61	24	Pass
	CH116	5580	15.85	24	Pass
	CH140	5700	15.35	24	Pass

☒ 802.11n-HT40

Band	Channel Number	Channel Freq. (MHz)	Conducted Output Power(dBm)	Limit (dBm)	Verdict
U-NII – 2C	CH102	5510	15.07	24	Pass
	CH110	5550	15.78	24	Pass
	CH134	5670	15.85	24	Pass

☒ 802.11 ac (VHT40)

Band	Channel Number	Channel Freq. (MHz)	Conducted Output Power(dBm)	Limit (dBm)	Verdict
U-NII – 2C	CH102	5510	15.92	24	Pass
	CH110	5550	15.74	24	Pass
	CH134	5670	15.02	24	Pass

☒ 802.11 ac (VHT80)

Band	Channel Number	Channel Freq. (MHz)	Conducted Output Power(dBm)	Limit (dBm)	Verdict
U-NII – 2C	CH106	5530	15.39	24	Pass

☒ 802.11a mode

Band	Channel Number	Channel Freq. (MHz)	Conducted Output Power(dBm)	Limit (dBm)	Verdict
U-NII – 3	CH149	5745	15.52	30	Pass
	CH157	5785	15.28	30	Pass
	CH165	5825	15.14	30	Pass

☒ 802.11n-HT20

Band	Channel Number	Channel Freq. (MHz)	Conducted Output Power(dBm)	Limit (dBm)	Verdict
U-NII – 3	CH149	5745	15.16	30	Pass
	CH157	5785	15.57	30	Pass
	CH165	5825	15.64	30	Pass

☒ 802.11 ac (VHT20)

Band	Channel Number	Channel Freq. (MHz)	Conducted Output Power(dBm)	Limit (dBm)	Verdict
U-NII – 3	CH149	5745	15.16	30	Pass
	CH157	5785	15.27	30	Pass
	CH165	5825	15.03	30	Pass

☒ 802.11n-HT40

Band	Channel Number	Channel Freq. (MHz)	Conducted Output Power(dBm)	Limit (dBm)	Verdict
U-NII – 3	CH151	5755	15.38	30	Pass
	CH159	5795	15.67	30	Pass

☒ 802.11 ac (VHT40)

Band	Channel Number	Channel Freq. (MHz)	Conducted Output Power(dBm)	Limit (dBm)	Verdict
U-NII – 3	CH151	5755	15.45	30	Pass
	CH159	5795	15.72	30	Pass

☒ 802.11 ac (VHT80)

Band	Channel Number	Channel Freq. (MHz)	Conducted Output Power(dBm)	Limit (dBm)	Verdict
U-NII – 3	CH155	5775	15.26	30	Pass

1T1R - Antenna B

☒ 802.11a mode

Band	Channel Number	Channel Freq. (MHz)	Conducted Output Power(dBm)	Limit (dBm)	Verdict
U-NII - 1	CH36	5180	15.16	30	Pass
	CH40	5200	15.62	30	Pass
	CH48	5240	15.28	30	Pass

☒ 802.11n-HT20

Band	Channel Number	Channel Freq. (MHz)	Conducted Output Power(dBm)	Limit (dBm)	Verdict
U-NII - 1	CH36	5180	15.94	30	Pass
	CH40	5200	15.81	30	Pass
	CH48	5240	15.48	30	Pass

☒ 802.11 ac (VHT20)

Band	Channel Number	Channel Freq. (MHz)	Conducted Output Power(dBm)	Limit (dBm)	Verdict
U-NII - 1	CH36	5180	15.73	30	Pass
	CH40	5200	15.46	30	Pass
	CH48	5240	15.76	30	Pass

☒ 802.11n-HT40

Band	Channel Number	Channel Freq. (MHz)	Conducted Output Power(dBm)	Limit (dBm)	Verdict
U-NII - 1	CH38	5190	15.28	30	Pass
	CH46	5230	15.16	30	Pass

☒ 802.11 ac (VHT40)

Band	Channel Number	Channel Freq. (MHz)	Conducted Output Power(dBm)	Limit (dBm)	Verdict
U-NII - 1	CH38	5190	15.54	30	Pass
	CH46	5230	15.21	30	Pass

☒ 802.11 ac (VHT80)

Band	Channel Number	Channel Freq. (MHz)	Conducted Output Power(dBm)	Limit (dBm)	Verdict
U-NII - 1	CH42	5210	15.74	30	Pass

☒ 802.11a mode

Band	Channel Number	Channel Freq. (MHz)	Conducted Output Power(dBm)	Limit (dBm)	Verdict
U-NII – 2A	CH52	5260	15.14	24	Pass
	CH56	5280	15.68	24	Pass
	CH64	5320	15.78	24	Pass

☒ 802.11n-HT20

Band	Channel Number	Channel Freq. (MHz)	Conducted Output Power(dBm)	Limit (dBm)	Verdict
U-NII – 2A	CH52	5260	15.45	24	Pass
	CH56	5280	15.04	24	Pass
	CH64	5320	15.79	24	Pass

☒ 802.11 ac (VHT20)

Band	Channel Number	Channel Freq. (MHz)	Conducted Output Power(dBm)	Limit (dBm)	Verdict
U-NII – 2A	CH52	5260	15.26	24	Pass
	CH56	5280	15.96	24	Pass
	CH64	5320	15.01	24	Pass

☒ 802.11n-HT40

Band	Channel Number	Channel Freq. (MHz)	Conducted Output Power(dBm)	Limit (dBm)	Verdict
U-NII – 2A	CH54	5270	15.54	24	Pass
	CH62	5310	15.89	24	Pass

☒ 802.11 ac (VHT40)

Band	Channel Number	Channel Freq. (MHz)	Conducted Output Power(dBm)	Limit (dBm)	Verdict
U-NII – 2A	CH54	5270	15.12	24	Pass
	CH62	5310	15.29	24	Pass

☒ 802.11 ac (VHT80)

Band	Channel Number	Channel Freq. (MHz)	Conducted Output Power(dBm)	Limit (dBm)	Verdict
U-NII – 2A	CH58	5290	15.33	24	Pass

☒ 802.11a mode

Band	Channel Number	Channel Freq. (MHz)	Conducted Output Power(dBm)	Limit (dBm)	Verdict
U-NII – 2C	CH100	5500	15.19	24	Pass
	CH116	5580	15.28	24	Pass
	CH140	5700	15.52	24	Pass

☒ 802.11n-HT20

Band	Channel Number	Channel Freq. (MHz)	Conducted Output Power(dBm)	Limit (dBm)	Verdict
U-NII – 2C	CH100	5500	15.43	24	Pass
	CH116	5580	15.54	24	Pass
	CH140	5700	15.71	24	Pass

☒ 802.11 ac (VHT20)

Band	Channel Number	Channel Freq. (MHz)	Conducted Output Power(dBm)	Limit (dBm)	Verdict
U-NII – 2C	CH100	5500	15.51	24	Pass
	CH116	5580	15.06	24	Pass
	CH140	5700	15.13	24	Pass

☒ 802.11n-HT40

Band	Channel Number	Channel Freq. (MHz)	Conducted Output Power(dBm)	Limit (dBm)	Verdict
U-NII – 2C	CH102	5510	15.08	24	Pass
	CH110	5550	15.39	24	Pass
	CH134	5670	15.65	24	Pass

☒ 802.11 ac (VHT40)

Band	Channel Number	Channel Freq. (MHz)	Conducted Output Power(dBm)	Limit (dBm)	Verdict
U-NII – 2C	CH102	5510	15.27	24	Pass
	CH110	5550	15.51	24	Pass
	CH134	5670	15.21	24	Pass

☒ 802.11 ac (VHT80)

Band	Channel Number	Channel Freq. (MHz)	Conducted Output Power(dBm)	Limit (dBm)	Verdict
U-NII – 2C	CH106	5530	15.62	24	Pass

☒ 802.11a mode

Band	Channel Number	Channel Freq. (MHz)	Conducted Output Power(dBm)	Limit (dBm)	Verdict
U-NII – 3	CH149	5745	15.69	30	Pass
	CH157	5785	15.57	30	Pass
	CH165	5825	15.36	30	Pass

☒ 802.11n-HT20

Band	Channel Number	Channel Freq. (MHz)	Conducted Output Power(dBm)	Limit (dBm)	Verdict
U-NII – 3	CH149	5745	15.26	30	Pass
	CH157	5785	15.35	30	Pass
	CH165	5825	15.91	30	Pass

☒ 802.11 ac (VHT20)

Band	Channel Number	Channel Freq. (MHz)	Conducted Output Power(dBm)	Limit (dBm)	Verdict
U-NII – 3	CH149	5745	15.23	30	Pass
	CH157	5785	15.45	30	Pass
	CH165	5825	15.52	30	Pass

☒ 802.11n-HT40

Band	Channel Number	Channel Freq. (MHz)	Conducted Output Power(dBm)	Limit (dBm)	Verdict
U-NII – 3	CH151	5755	15.02	30	Pass
	CH159	5795	15.93	30	Pass

☒ 802.11 ac (VHT40)

Band	Channel Number	Channel Freq. (MHz)	Conducted Output Power(dBm)	Limit (dBm)	Verdict
U-NII – 3	CH151	5755	15.23	30	Pass
	CH159	5795	15.72	30	Pass

☒ 802.11 ac (VHT80)

Band	Channel Number	Channel Freq. (MHz)	Conducted Output Power(dBm)	Limit (dBm)	Verdict
U-NII – 3	CH155	5775	15.44	30	Pass

For 2T2R

802.11n-HT20-Total

Band	Channel Number	Channel Freq. (MHz)	ANT 1	ANT 2	Total	Limit (dBm)	Verdict
			(dBm)	(dBm)	(dBm)		
U-NII - 1	CH36	5180	15.21	15.94	18.60	30	Pass
	CH40	5200	15.23	15.81	18.54	30	Pass
	CH48	5240	15.01	15.48	18.26	30	Pass

802.11 ac (VHT20) -Total

Band	Channel Number	Channel Freq. (MHz)	ANT 1	ANT 2	Total	Limit (dBm)	Verdict
			(dBm)	(dBm)	(dBm)		
U-NII - 1	CH36	5180	15.22	15.73	18.49	30	Pass
	CH40	5200	15.07	15.46	18.28	30	Pass
	CH48	5240	15.44	15.76	18.61	30	Pass

802.11n-HT40 -Total

Band	Channel Number	Channel Freq. (MHz)	ANT 1	ANT 2	Total	Limit (dBm)	Verdict
			(dBm)	(dBm)	(dBm)		
U-NII - 1	CH38	5190	15.46	15.28	18.38	30	Pass
	CH46	5230	15.89	15.16	18.55	30	Pass

802.11 ac (VHT40) -Total

Band	Channel Number	Channel Freq. (MHz)	ANT 1	ANT 2	Total	Limit (dBm)	Verdict
			(dBm)	(dBm)	(dBm)		
U-NII - 1	CH38	5190	15.73	15.54	18.65	30	Pass
	CH46	5230	15.43	15.21	18.33	30	Pass

802.11 ac (VHT80) -Total

Band	Channel Number	Channel Freq. (MHz)	ANT 1	ANT 2	Total	Limit (dBm)	Verdict
			(dBm)	(dBm)	(dBm)		
U-NII - 1	CH42	5210	15.36	15.74	18.56	30	Pass

☒ 802.11n-HT20-Total

Band	Channel Number	Channel Freq. (MHz)	ANT 1	ANT 2	Total	Limit (dBm)	Verdict
			(dBm)	(dBm)	(dBm)		
U-NII – 2A	CH52	5260	15.03	15.45	18.26	24	Pass
	CH56	5280	15.22	15.04	18.14	24	Pass
	CH64	5320	15.02	15.79	18.43	24	Pass

☒ 802.11 ac (VHT20) -Total

Band	Channel Number	Channel Freq. (MHz)	ANT 1	ANT 2	Total	Limit (dBm)	Verdict
			(dBm)	(dBm)	(dBm)		
U-NII – 2A	CH52	5260	15.89	15.26	18.60	24	Pass
	CH56	5280	15.95	15.96	18.97	24	Pass
	CH64	5320	15.58	15.01	18.31	24	Pass

☒ 802.11n-HT40-Total

Band	Channel Number	Channel Freq. (MHz)	ANT 1	ANT 2	Total	Limit (dBm)	Verdict
			(dBm)	(dBm)	(dBm)		
U-NII – 2A	CH54	5270	15.29	15.54	18.43	24	Pass
	CH62	5310	15.43	15.89	18.68	24	Pass

☒ 802.11 ac (VHT40) -Total

Band	Channel Number	Channel Freq. (MHz)	ANT 1	ANT 2	Total	Limit (dBm)	Verdict
			(dBm)	(dBm)	(dBm)		
U-NII – 2A	CH54	5270	15.49	15.12	18.32	24	Pass
	CH62	5310	15.54	15.29	18.43	24	Pass

☒ 802.11 ac (VHT80) -Total

Band	Channel Number	Channel Freq. (MHz)	ANT 1	ANT 2	Total	Limit (dBm)	Verdict
			(dBm)	(dBm)	(dBm)		
U-NII – 2A	CH58	5290	15.21	15.33	18.28	24	Pass

☒ 802.11n-HT20-Total

Band	Channel Number	Channel Freq. (MHz)	ANT 1	ANT 2	Total	Limit (dBm)	Verdict
			(dBm)	(dBm)	(dBm)		
U-NII – 2C	CH100	5500	15.69	15.43	18.57	24	Pass
	CH116	5580	15.51	15.54	18.54	24	Pass
	CH140	5700	15.78	15.71	18.76	24	Pass

☒ 802.11 ac (VHT20) -Total

Band	Channel Number	Channel Freq. (MHz)	ANT 1	ANT 2	Total	Limit (dBm)	Verdict
			(dBm)	(dBm)	(dBm)		
U-NII – 2C	CH100	5500	15.61	15.51	18.57	24	Pass
	CH116	5580	15.85	15.06	18.48	24	Pass
	CH140	5700	15.35	15.13	18.25	24	Pass

☒ 802.11n-HT40 -Total

Band	Channel Number	Channel Freq. (MHz)	ANT 1	ANT 2	Total	Limit (dBm)	Verdict
			(dBm)	(dBm)	(dBm)		
U-NII – 2C	CH102	5510	15.07	15.08	18.09	24	Pass
	CH116	5580	15.78	15.39	18.60	24	Pass
	CH134	5670	15.85	15.65	18.76	24	Pass

☒ 802.11 ac (VHT40) -Total

Band	Channel Number	Channel Freq. (MHz)	ANT 1	ANT 2	Total	Limit (dBm)	Verdict
			(dBm)	(dBm)	(dBm)		
U-NII – 2C	CH102	5510	15.92	15.27	18.62	24	Pass
	CH110	5550	15.74	15.51	18.64	24	Pass
	CH134	5670	15.02	15.21	18.13	24	Pass

☒ 802.11 ac (VHT80) -Total

Band	Channel Number	Channel Freq. (MHz)	ANT 1	ANT 2	Total	Limit (dBm)	Verdict
			(dBm)	(dBm)	(dBm)		
U-NII – 2C	CH106	5530	15.39	15.62	18.52	24	Pass

☒ 802.11n-HT20-Total

Band	Channel Number	Channel Freq. (MHz)	ANT 1	ANT 2	Total	Limit (dBm)	Verdict
			(dBm)	(dBm)	(dBm)		
U-NII – 3	CH149	5745	15.16	15.26	18.22	30	Pass
	CH157	5785	15.57	15.35	18.47	30	Pass
	CH165	5825	15.64	15.91	18.79	30	Pass

☒ 802.11 ac (VHT20) -Total

Band	Channel Number	Channel Freq. (MHz)	ANT 1	ANT 2	Total	Limit (dBm)	Verdict
			(dBm)	(dBm)	(dBm)		
U-NII – 3	CH149	5745	15.16	15.23	18.21	30	Pass
	CH157	5785	15.27	15.45	18.37	30	Pass
	CH165	5825	15.03	15.52	18.29	30	Pass

☒ 802.11n-HT40-Total

Band	Channel Number	Channel Freq. (MHz)	ANT 1	ANT 2	Total	Limit (dBm)	Verdict
			(dBm)	(dBm)	(dBm)		
U-NII – 3	CH151	5755	15.38	15.02	18.21	30	Pass
	CH159	5795	15.67	15.93	18.81	30	Pass

☒ 802.11 ac (VHT40) -Total

Band	Channel Number	Channel Freq. (MHz)	ANT 1	ANT 2	Total	Limit (dBm)	Verdict
			(dBm)	(dBm)	(dBm)		
U-NII – 3	CH151	5755	15.45	15.23	18.35	30	Pass
	CH159	5795	15.72	15.72	18.73	30	Pass

☒ 802.11 ac (VHT80) -Total

Band	Channel Number	Channel Freq. (MHz)	ANT 1	ANT 2	Total	Limit (dBm)	Verdict
			(dBm)	(dBm)	(dBm)		
U-NII – 3	CH155	5775	15.26	15.44	18.36	30	Pass