



# FCC Part 15C Test Report

## FCC ID: 2AF9RWETEK

Product Name:	Android tv box
Trademark:	WETEK
Model Name :	Wetek Core, Wetek Core Light, Wetek Openelec, Wetek Core Openelec+, wetek play, wetek play plus, wetek play+, Wetek Pro, Wetek plus., Wetek
Prepared For :	<b>WeTek Electronics Limited</b>
Address :	Level 10, Central Building, 1-3 Pedder Street, Central, Hong Kong
Prepared By :	<b>Shenzhen BCTC Technology Co., Ltd.</b>
Address :	No.101,Yousong Road,Longhua New District, Shenzhen,China
Test Date:	Oct. 12 - Oct. 24, 2015
Date of Report :	Oct. 25, 2015
Report No.:	BCTC-151012610



## VERIFICATION OF COMPLIANCE

**Applicant's name** ..... **WeTek Electronics Limited**

**Address**..... Level 10, Central Building, 1-3 Pedder Street, Central, Hong Kong

**Manufacture's Name** ..... **Videstro Technology Co., Ltd**

**Address**..... 402A, Building B, Donglian Industrial 23rd District Bao'an, Shenzhen China

**Product description**

**Product name**..... Android tv box

**Model Name:** Wetek Core, Wetek Core Light, Wetek Openelec, Wetek Core Openelec+, wetek play, wetek play plus, wetek play+, Wetek Pro, Wetek plus., Wetek

**Test procedure** FCC Part15.407

**Standards** ANSI C63.10-2013

KDB789033 D02 General UNII Test Procedures New Rules v01

This device described above has been tested by BCTC, and the test results show that the equipment under test (EUT) is in compliance with the FCC requirements. And it is applicable only to the tested sample identified in the report.

This report shall not be reproduced except in full, without the written approval of BCTC, this document may be altered or revised by BCTC, personal only, and shall be noted in the revision of the document.

**Test Result** **Pass**

**Testing Engineer** : Eric Yang  
(Eric Yang)

**Technical Manager** : Sophie Lee  
(Sophia Lee)

**Authorized Signatory** : Carson Zhang  
(Carson. Zhang)







## 1. TEST SUMMARY

Test Items	Test Requirement	Result
Conducted Emissions	15.207	PASS
Radiated Emissions	15.407(b), 15.209	PASS
26dB bandwidth and 99%dB Bandwidth	15.403(i) 15.407(e)	PASS
Power density	15.407 (a)	PASS
Maximum Peak Output Power	15.407 (a)	PASS
Emissions from out of band	15.407 (b)	PASS
Transmission in case of Absence of Information	15.407(c)	PASS
Frequency Stability	15.407(g)	PASS
Antenna Requirement	15.203	PASS



## 2.GENERAL PRODUCT INFORMATION

### 2.1. Product Function

Refer to Technical Construction Form and User Manual.

### 2.2. Description of Device (EUT)

Product Name:	Android tv box
Model No.:	Wetek Core, Wetek Core Light, Wetek Openelec, Wetek Core Openelec+, wetek play, wetek play plus, wetek play+, Wetek Pro, Wetek plus., Wetek
Trade Name:	WETEK
Operation Frequency:	5180-5240 5745-5825MHz(5G 802.11a/n(HT20)) 5180-5240, 5755-5795 MHz(802.11n(HT40))
Channel numbers:	See channel list
Modulation technology:	64QAM, 16QAM, QPSK, BPSK for OFDM
Data speed (IEEE 802.11a):	6Mbps, 9Mbps, 12Mbps, 18Mbps, 24Mbps, 36Mbps, 48Mbps,54Mbps
Data speed (IEEE 802.11n):	Up to 150Mbps
Antenna Type:	Internal antenna
Antenna gain:	3.5dBi
Power supply:	DC 12V from adapter
Adapter:	Model:JK120100-S04USA I/P:AC 100-240V 50/60Hz O/P:DC 12V/1A

Channel	Frequency (MHz)	Channel	Frequency (MHz)
36	5180	44	5220
40	5200	48	5240



Channel List for 802.11a/n(20)			
Channel	Frequency (MHz)	Channel	Frequency (MHz)
149	5745	161	5805
153	5765	165	5825
157	5785		

Channel List for 802.11n(40)			
Channel	Frequency (MHz)	Channel	Frequency (MHz)
38	5190	46	5230

Channel List for 802.11n(40)			
Channel	Frequency (MHz)	Channel	Frequency (MHz)
106	5755	161	5795



### 2.3. Test Supporting System

None.

### 2.4. Independent Operation Modes

The basic operation modes are:

These is Digital Transmission system (DTS) and have modulation OFDM, DSSS, DBPSK, DQPSK, CCK, 16QAM, 64QAM. According exploratory test, EUT will have maximum output power in those data rate (802.11a/n: MCS0), so those data rate were used for all test. The equipment enables high-speed access without wires to network assets. This adapter uses the IEEE 802.11 protocol to enable wireless communications between the host and Wireless router.

802.11a/n(20)

Frequency	Band 1	Band 4
Low	5180MHz	5745MHz
Middle	5200MHz	5785MHz
High	5240MHz	5825MHz

802.11n(40)

Frequency	Band 1	Band 4
Low	5190MHz	5755MHz
Middle	5230MHz	5795MHz
High		

Note: for conducted emission test, we pretest all mode,the worst mode was 802.11a channel 36.  
for radiated emissions test, we pretest all mode,the worst mode was 802.11a/n20  
The worst mode's data was recording and show in the test report.

### 2.5. Test Sites

#### 2.5.1. Test Facilities

Lab Qualifications : FCC Registration No.:187086



### 3. TEST SET-UP AND OPERATION MODES

#### 3.1. Principle of Configuration Selection

**Emission:** The equipment under test (EUT) was configured to measure its highest possible radiation level. The test modes were adapted accordingly in reference to the Operating Instructions.

#### 3.2. Block Diagram of Test Set-up

System Diagram of Connections between EUT and Simulators

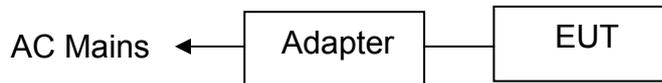

*(EUT: Android tv box)*

#### 3.3. Test Operation Mode and Test Software

None.

#### 3.4. Special Accessories and Auxiliary Equipment

#### 3.5. Countermeasures to Achieve EMC Compliance

None.



## 4. EMISSION TEST RESULTS

### 4.1. Conducted Emission Measurement

POWER LINE CONDUCTED EMISSION Limits (Frequency Range 150KHz-30MHz)

FREQUENCY (MHz)	Class B (dBuV)		Standard
	Quasi -peak	Average	
0.15 -0.5	66 - 56 *	56 - 46 *	FCC
0.50 -5.0	56.00	46.00	FCC
5.0 -30.0	60.00	50.00	FCC

Note:

- (1) The tighter limit applies at the band edges.
- (2) The limit of " \* " marked band means the limitation decreases linearly with the logarithm of the frequency in the range.

The following table is the setting of the receiver

Receiver Parameters	Setting
Attenuation	10 dB
Start Frequency	0.15 MHz
Stop Frequency	30 MHz
IF Bandwidth	9 kHz

#### 4.1.1. TEST PROCEDURE

- a. The EUT was placed 0.8 meters from the horizontal ground plane with EUT being connected to the power mains through a line impedance stabilization network (LISN). All other support equipments powered from additional LISN(s). The LISN provide 50 Ohm/ 50uH of coupling impedance for the measuring instrument.
- b. Interconnecting cables that hang closer than 40 cm to the ground plane shall be folded back and forth in the center forming a bundle 30 to 40 cm long.
- c. I/O cables that are not connected to a peripheral shall be bundled in the center. The end of the cable may be terminated, if required, using the correct terminating impedance. The overall length shall not exceed 1 m.
- d. LISN at least 80 cm from nearest part of EUT chassis.
- e. For the actual test configuration, please refer to the related Item –EUT Test Photos.

#### 4.1.2. DEVIATION FROM TEST STANDARD

No deviation

#### 4.1.3. TEST SETUP

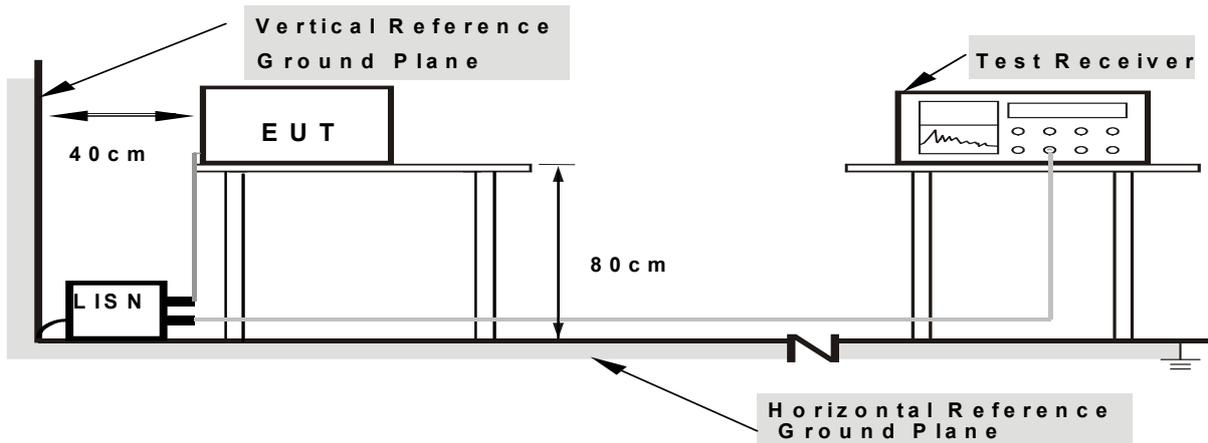

**Note: 1.** Support units were connected to second LISN.  
**2.** Both of LISNs (AMN) are 80 cm from EUT and at least 80 cm from other units and other metal planes

#### 4.1.4. EUT OPERATING CONDITIONS

The EUT was configured for testing in a typical fashion (as a customer would normally use it). The EUT has been programmed to continuously transmit during test. This operating condition was tested and used to collect the included data.

We pretest all adapter's emission, only the adapter 1's data was worst and the data was recording in the report.

The data only show the worst mode.

If peak level comply with Quasi-Peak limit, then the Quasi-Peak level is deemed to comply with Quasi-Peak limit.

We pretest AC 120V and AC 240V, the worst voltage was AC 120V and the data recording in the report.







#### 4.2. Radiated Emission Measurement

##### 4.2.1. Radiated Emission Limits (Frequency Range 9kHz-1000MHz)

20dBc in any 100 kHz bandwidth outside the operating frequency band. In case the emission fall within the restricted band specified on 15.205(a), then the 15.209(a) limit in the table below has to be followed.

Frequencies (MHz)	Field Strength (microvolts/meter)	Measurement Distance (meters)
0.009~0.490	2400/F(KHz)	300
0.490~1.705	24000/F(KHz)	30
1.705~30.0	30	30
30~88	100	3
88~216	150	3
216~960	200	3
Above 960	500	3

##### LIMITS OF RADIATED EMISSION MEASUREMENT (Above 1000MHz)

FREQUENCY (MHz)	Class B (dBuV/m) (at 3M)	
	PEAK	AVERAGE
Above 1000	74	54

**Notes:**

- (1) The limit for radiated test was performed according to FCC PART 15C.
- (2) The tighter limit applies at the band edges.
- (3) Emission level (dBuV/m)=20log Emission level (uV/m).

##### FREQUENCY RANGE OF RADIATED MEASUREMENT (For unintentional radiators)

Highest frequency generated or Upper frequency of measurement used in the device or on which the device operates or tunes (MHz)	Range (MHz)
Below 1.705	30
1.705 – 108	1000
108 – 500	2000
500 – 1000	5000
Above 1000	5th harmonic of the highest frequency or 40 GHz, whichever is lower



Spectrum Parameter	Setting
Attenuation	Auto
Start Frequency	1000 MHz
Stop Frequency	10th carrier harmonic
RB / VB (emission in restricted band)	1 MHz / 1 MHz for Peak, 1 MHz / 10Hz for Average

Receiver Parameter	Setting
Attenuation	Auto
Start ~ Stop Frequency	9kHz~150kHz / RB 200Hz for QP
Start ~ Stop Frequency	150kHz~30MHz / RB 9kHz for QP
Start ~ Stop Frequency	30MHz~1000MHz / RB 120kHz for QP

#### 4.2.2. TEST PROCEDURE

- The measuring distance of at 3 m shall be used for measurements at frequency up to 25GHz. For frequencies above 1GHz, any suitable measuring distance may be used.
- The EUT was placed on the top of a rotating table 1.5 meters above the ground at a 3 meter open area test site. The table was rotated 360 degrees to determine the position of the highest radiation.
- The height of the equipment or of the substitution antenna shall be 1.5 m; the height of the test antenna shall vary between 1 m to 4 m. Both horizontal and vertical polarizations of the antenna are set to make the measurement.
- The initial step in collecting conducted emission data is a spectrum analyzer peak detector mode pre-scanning the measurement frequency range. Significant peaks are then marked and then Quasi Peak detector mode re-measured.
- If the Peak Mode measured value compliance with and lower than Quasi Peak Mode Limit, the EUT shall be deemed to meet QP Limits and then no additional QP Mode measurement performed.
- For the actual test configuration, please refer to the related Item –EUT Test Photos.
- For the radiated emission test above 1GHz:
 

Place the measurement antenna away from each area of the EUT determined to be a source of emissions at the specified measurement distance, while keeping the measurement antenna aimed at the source of emissions at each frequency of significant emissions, with polarization oriented for maximum response. The measurement antenna may have to be higher or lower than the EUT, depending on the radiation pattern of the emission and staying aimed at the emission source for receiving the maximum signal. The final measurement antenna elevation shall be that which maximizes the emissions. The measurement antenna elevation for maximum emissions shall be restricted to a range of heights of from 1 m to 4 m above the ground or reference ground plane.

Note:

Both horizontal and vertical antenna polarities were tested and performed pretest to three orthogonal axis. The worst case emissions were reported

We pretest AC 120V and AC 240V, the worst voltage was AC 120V and the data recording in the report.

#### 4.2.3. DEVIATION FROM TEST STANDARD

No deviation

#### 4.2.4. TEST SETUP

##### (A) Radiated Emission Test-Up Frequency Below 30MHz

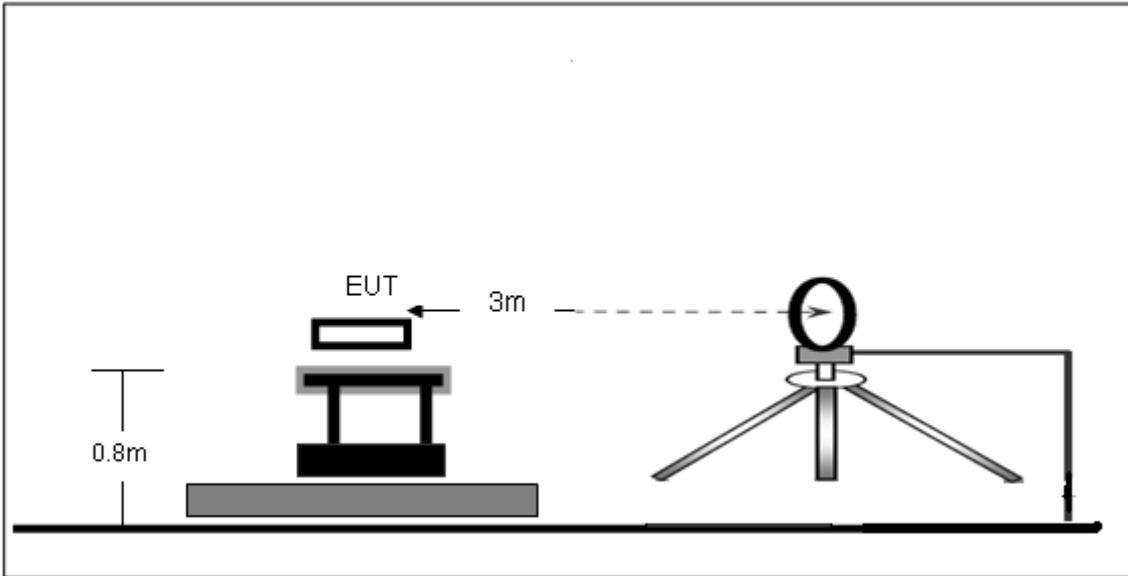

##### (B) Radiated Emission Test-Up Frequency 30MHz~1GHz

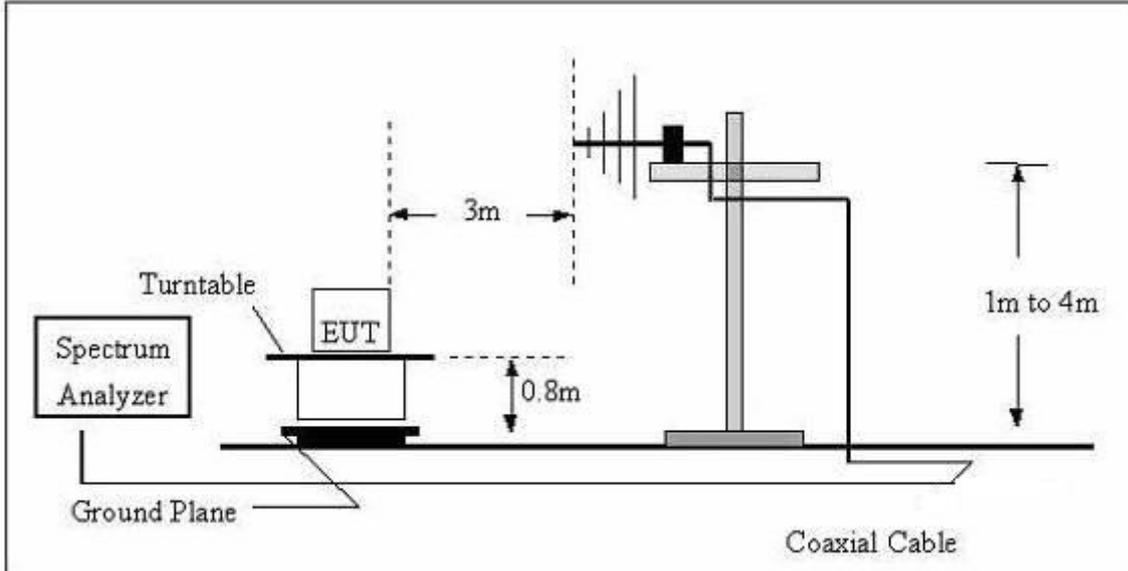

### (C) Radiated Emission Test-Up Frequency Above 1GHz

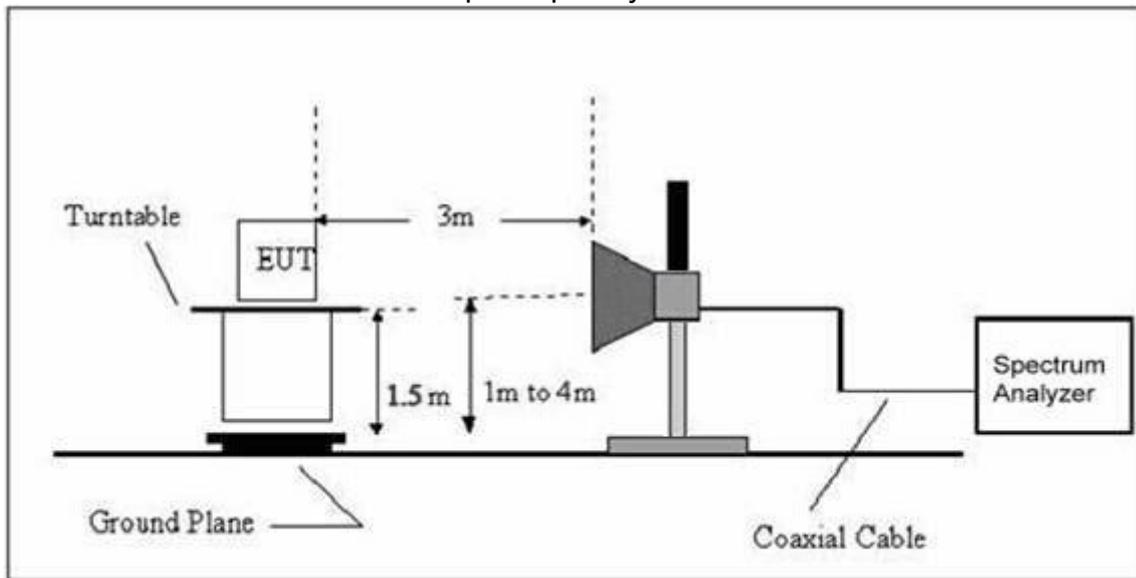

#### 4.2.5. EUT OPERATING CONDITIONS

The EUT tested system was configured as the statements of 2.4 Unless otherwise a special operating condition is specified in the follows during the testing.

We pretest all adapter's emission, only the adapter 1's data was worst and the data was recording in the report.

The data only show the worst mode.



## Radiated Spurious Emission (Below 30MHz )

EUT :	Android tv box	Model Name :	Wetek Core
Temperature :	20 °C	Relative Humidity :	48%
Pressure :	1010 hPa	Polarization :	---
Test Voltage :	DC 12V from adapter		
Test Mode :	TX		

Freq.	Reading	Limit	Margin	State
(MHz)	(dBuV/m)	(dBuV/m)	(dB)	P/F
--	--	--	--	PASS
--	--	--	--	PASS

## Note:

The amplitude of spurious emissions which are attenuated by more than 20dB below the permissible value has no need to be reported.

Distance extrapolation factor =  $40 \log(\text{specific distance}/\text{test distance})$ (dB);

Limit line = specific limits(dBuv) + distance extrapolation factor.





EUT :	Android tv box	Model Name :	Wetek Core
Temperature :	26 °C	Relative Humidity :	54%
Pressure :	1010 hPa	Polarization :	Vertical
Test Voltage :	DC 12V from adapter		
Test Mode : (Worst)	802.11a low channel		

No. Mk.	Freq.	Reading Level	Correct Factor	Measurement	Limit	Over	Antenna Height	Table Degree
	MHz	dBuV	dB/m	dBuV/m	dBuV/m	dB	cm	degree
1	42.7496	37.48	-9.18	28.30	40.00	-11.70	QP	
2	52.0251	42.17	-10.63	31.54	40.00	-8.46	QP	
3	* 63.0916	45.28	-12.13	33.15	40.00	-6.85	QP	
4	77.8654	41.27	-17.33	23.94	40.00	-16.06	QP	
5	129.9226	38.40	-14.11	24.29	43.50	-19.21	QP	
6	938.8326	26.39	-0.70	25.69	46.00	-20.31	QP	

Remark:

Factor = Antenna Factor + Cable Loss – Pre-amplifier.  
 All interfaces was connected, and BT TX mode was link.

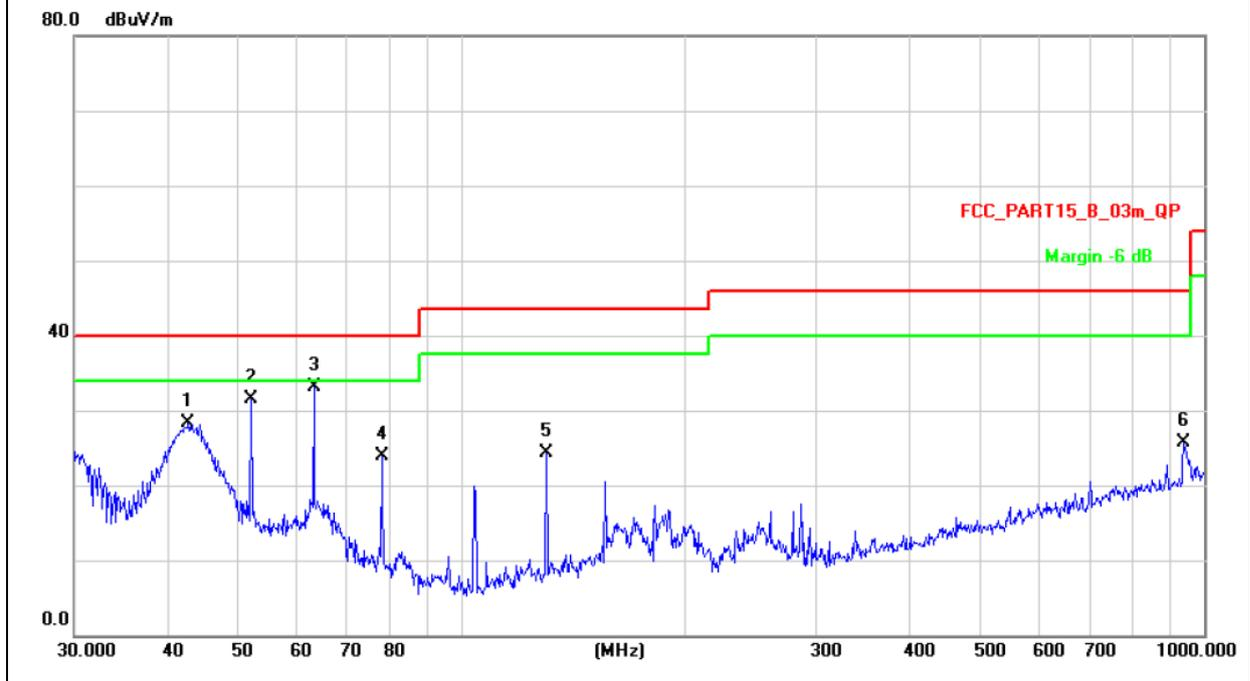











## **5. BAND EDGE COMPLIANCE TEST**

### **5.1. Limits**

(1) For transmitters operating in the 5.15-5.25 GHz band: All emissions outside of the 5.15-5.35 GHz band shall not exceed an e.i.r.p. of  $-27$  dBm/MHz.

(4) For transmitters operating in the 5.725-5.85 GHz band: All emissions within the frequency range from the band edge to 10 MHz above or below the band edge shall not exceed an e.i.r.p. of  $-17$  dBm/MHz; for frequencies 10 MHz or greater above or below the band edge, emissions shall not exceed an e.i.r.p. of  $-27$  dBm/MHz.

### **5.2. Test setup**

Test method: FCC KDB 789033 G)& Parts 15.407(b)(4) & 15.209(a)

Same as Clause 4.2.

### **5.3. Test Data**

Please see data as below:

Note: we pretest horizontal and vertical, the worst was horizontal and show in the report.



Modulation	Test Frequency (MHz)	Max Level (dB $\mu$ V/m)	EIRP[dBm]	Limit[dBm]	Result
802.11a	5180	52.21	-42.99	-27.00	Pass
	5200	51.84	-43.36	-27.00	Pass
	5240	51.63	-43.57	-27.00	Pass
	5745	51.39	-43.81	-27.00	Pass
	5875	51.61	-43.59	-27.00	Pass
	5825	51.36	-43.84	-27.00	Pass
802.11n(HT20)	5180	52.03	-43.17	-27.00	Pass
	5200	51.66	-43.54	-27.00	Pass
	5240	51.91	-43.29	-27.00	Pass
	5745	51.51	-43.69	-27.00	Pass
	5875	51.36	-43.84	-27.00	Pass
	5825	51.84	-43.36	-27.00	Pass
802.11n(HT40)	5190	51.62	-43.58	-27.00	Pass
	5230	51.75	-43.45	-27.00	Pass
	5755	51.29	-43.91	-27.00	Pass
	5795	51.37	-43.83	-27.00	Pass

Remark: 1. According to KDB 789033 D02 section H) d) (iii), for measurement above 1000MHz@3m distance, the limit of EIRP is calculated as follows:  $EIRP[dBm] = E[dB\mu V/m] - 95.2$



## 6. 26DB AND 99% BANDWIDTH TEST

### 6.1. Measurement Procedure

The bandwidth at 26 dB down from the highest in-band spectral density is measured with a spectrum analyzer connected to the antenna terminal while the EUT is operating at its maximum power control level, as defined in KDB 789033, at the appropriate frequencies. The spectrum analyzer's bandwidth measurement function is configured to measure the 26 dB bandwidth.

The 26 dB bandwidth is used to determine the conducted power limits.

There is no limit bandwidth for U-NII-1, U-NII-2-A and U-NII-2-C.

The minimum of 6dB Bandwidth measurement is 0.5 MHz for U-NII-3

26dB bandwidth

	Frequency (MHz)	26dB Bandwidth (MHz)	99% Bandwidth (MHz)
802.11a	5180	22.48	16.51
	5200	22.12	16.48
	5240	22.49	16.49
802.11n (HT20)	5180	23.00	17.65
	5200	23.78	17.70
	5240	23.07	17.69
802.11n (HT40)	5190	43.22	36.17
	5230	42.81	36.14



## 6dB bandwidth

	<b>Frequency (MHz)</b>	<b>6dB Bandwidth (MHz)</b>	<b>99% Bandwidth (MHz)</b>	<b>Limit (MHz)</b>
802.11a	5745	13.91	16.39	>0.5
	5785	15.34	16.39	>0.5
	5825	12.35	16.40	>0.5
802.11n (HT20)	5745	13.90	17.58	>0.5
	5785	15.05	17.58	>0.5
	5825	13.82	17.59	>0.5
802.11n (HT40)	5755	35.14	35.92	>0.5
	5795	33.89	35.95	>0.5



### 802.11a 5180MHz



### 802.11a 5220MHz





802.11a 5240MHz

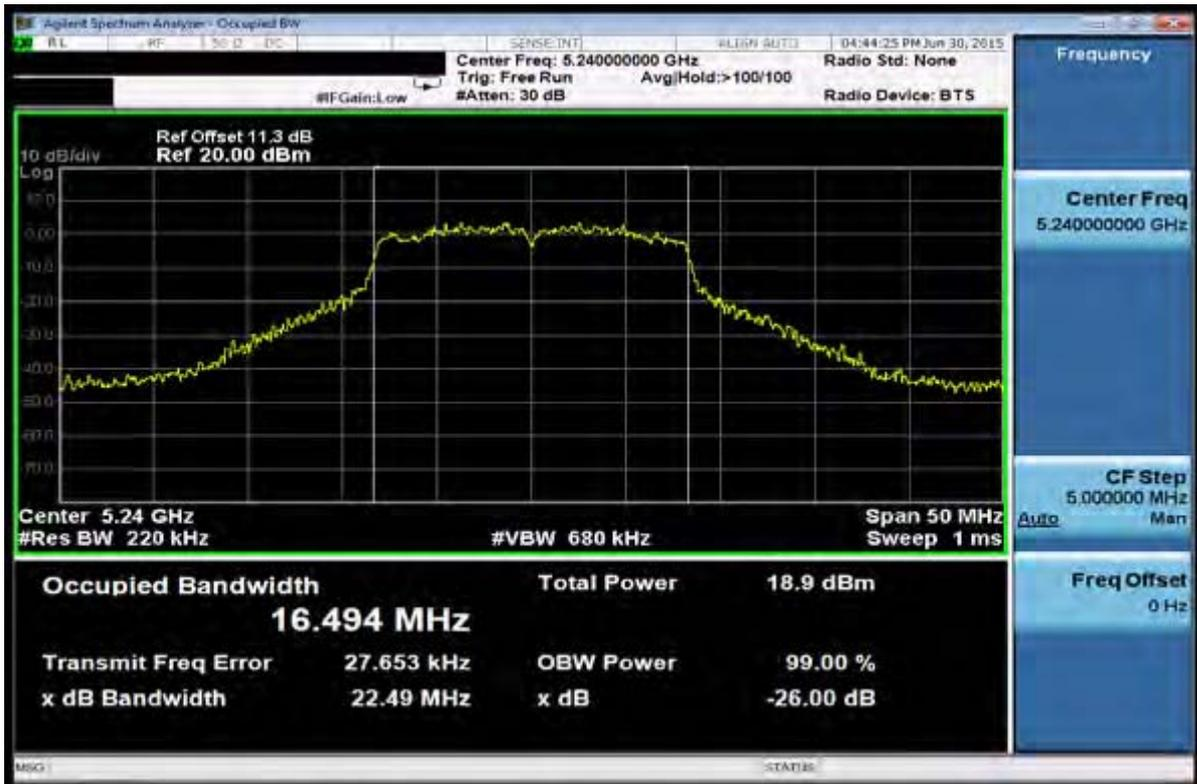

802.11n(HT20) 5180MHz





802.11n(HT20) 5220MHz



802.11n(HT20) 5240MHz

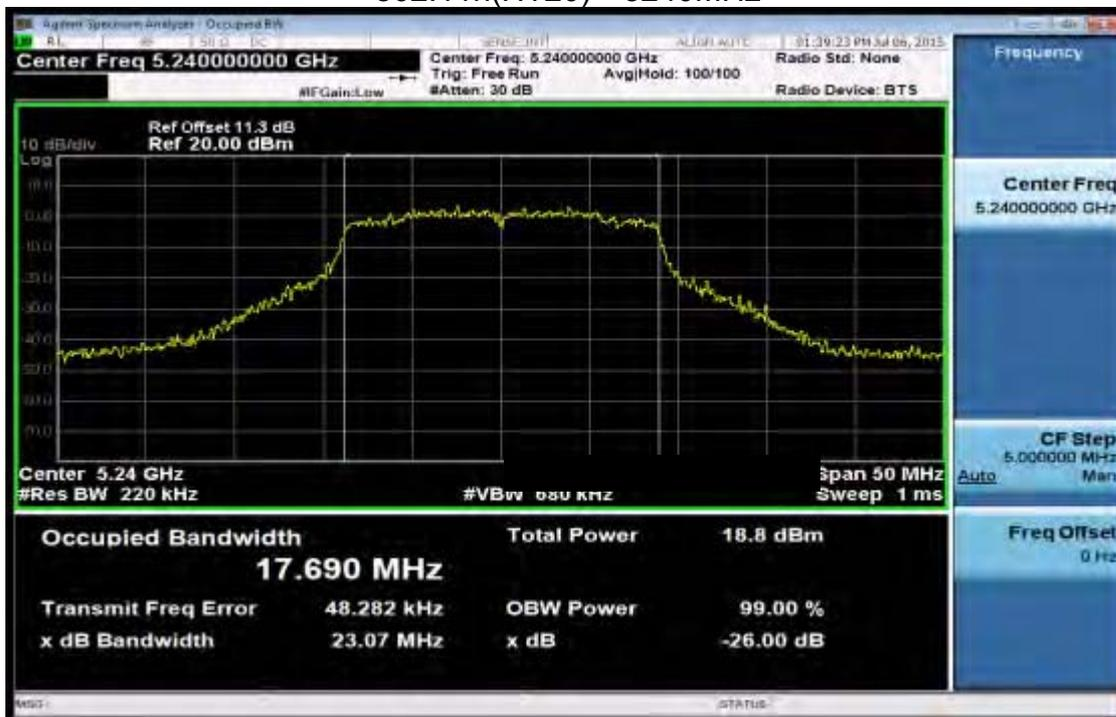

802.11n(HT40) 5190MHz

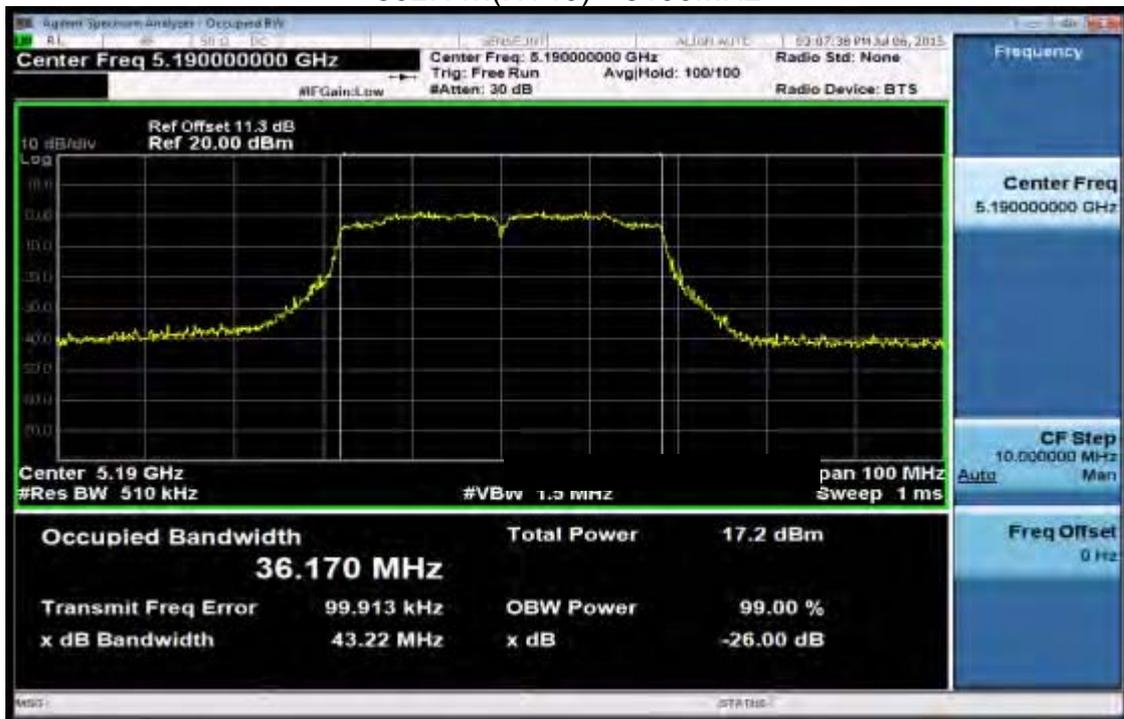

802.11n(HT40) 5230MHz





6dB bandwidth

802.11a 5745MHz

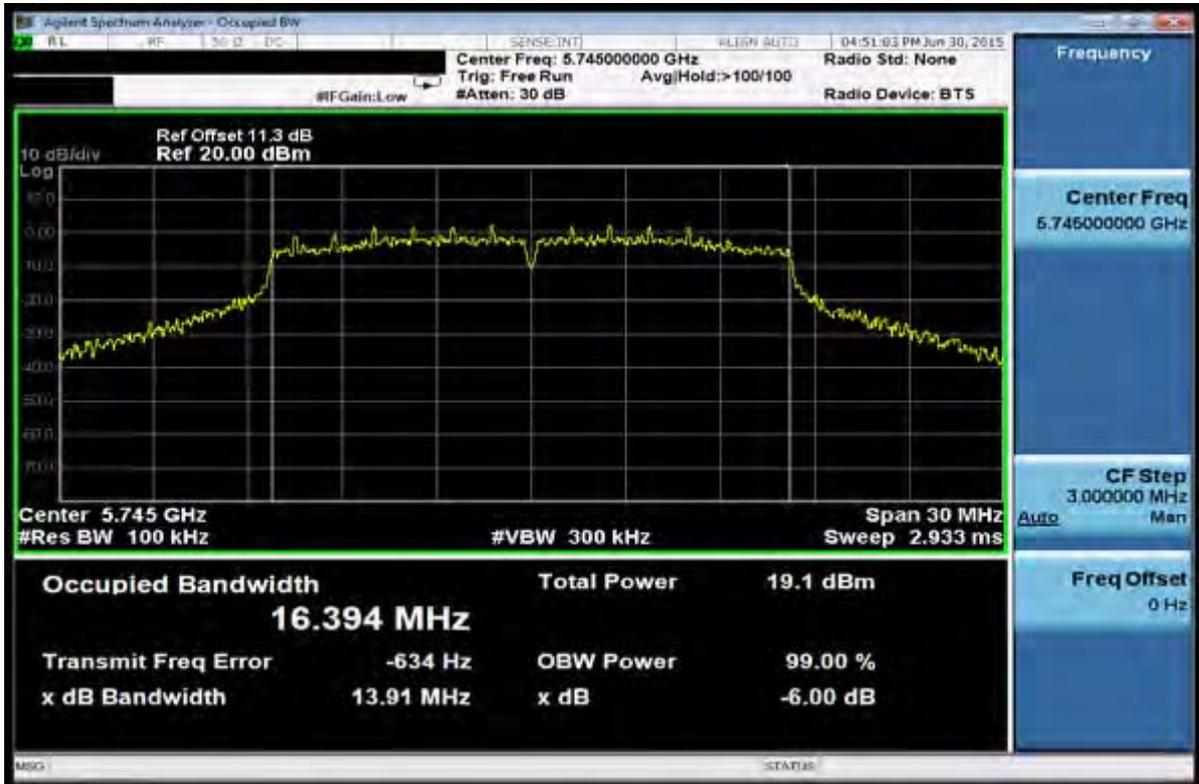

802.11a 5785MHz





### 802.11a 5825MHz

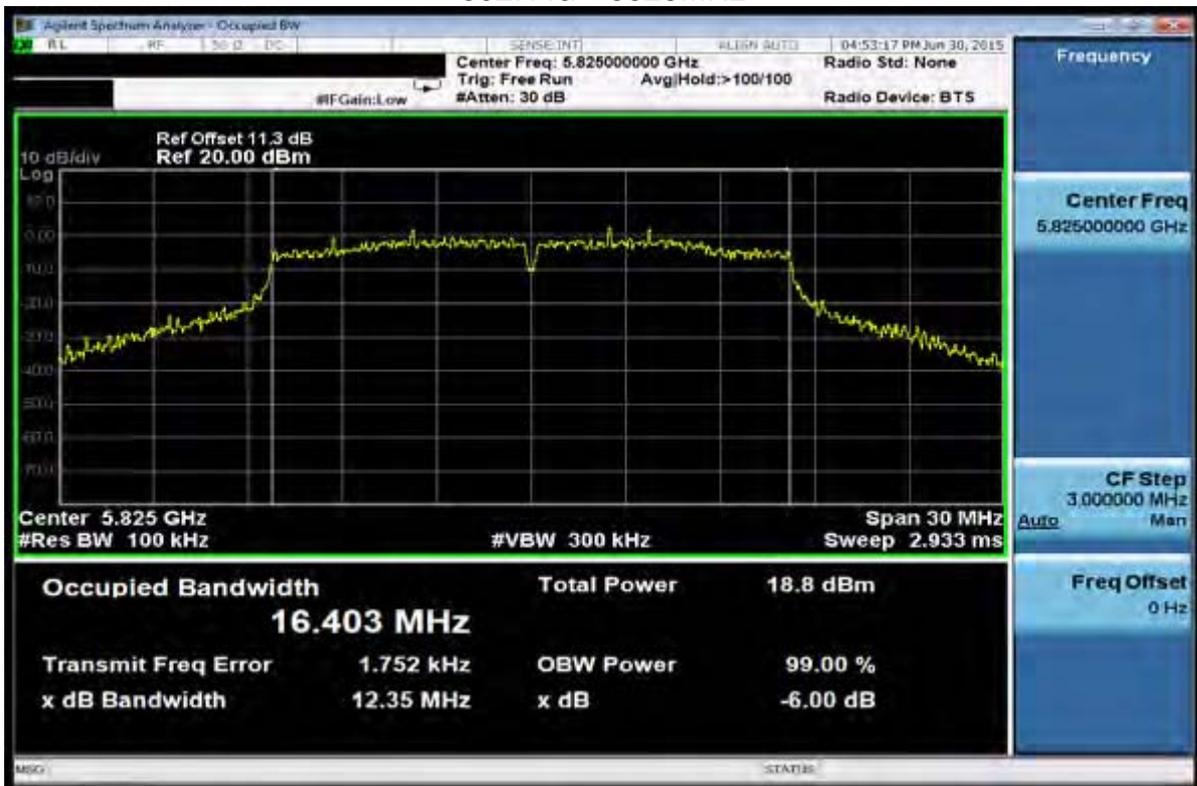

### 802.11n(HT20) 5745MHz





### 802.11n(HT20) 5785MHz



### 802.11n(HT20) 5825MHz





802.11n(HT40) 5755MHz



802.11n(HT40) 5795MHz





## 7. OUTPUT POWER TEST

### 7.1. Limits

For mobile and portable client devices in the 5.15-5.25 GHz band, the maximum conducted output power over the frequency band of operation shall not exceed 250 mW provided the maximum antenna gain does not exceed 6 dBi.

For the band 5.725-5.85 GHz, the maximum conducted output power over the frequency band of operation shall not exceed 1 W.

### 7.2. Test setup

1. The maximum average conducted output power can be measured using Method PM-G (Measurement using a gated RF average power meter):
2. Measurements may be performed using a wideband gated RF power meter provided that the gate parameters are adjusted such that the power is measured only when the EUT is transmitting at its maximum power control level. Since the measurement is made only during the ON time of the transmitter, no duty cycle correction factor is required.
  - a. The Transmitter output (antenna port) was connected to the power meter.
  - b. Turn on the EUT and power meter and then record the power value.
  - c. Repeat above procedures on all channels needed to be tested.

### 7.3. Test result

	Frequency (MHz)	Average Output Power(dBm)	Average Output Power(mW)	FCC Limit (dBm)	Result
802.11a	5180	15.84	38.37	23.98	Pass
	5220	15.66	36.81	23.98	Pass
	5240	15.67	36.90	23.98	Pass
	5745	14.75	29.85	30.0	Pass
	5785	14.67	29.31	30.0	Pass
	5825	14.62	28.97	30.0	Pass
802.11n (HT20)	5180	13.57	22.75	23.98	Pass
	5220	13.27	21.23	23.98	Pass
	5240	13.42	21.98	23.98	Pass
	5745	13.08	20.32	30.0	Pass
	5785	13.11	20.46	30.0	Pass
	5825	13.06	20.23	30.0	Pass
802.11n (HT40)	5190	12.79	19.01	23.98	Pass
	5230	12.34	17.14	23.98	Pass
	5755	12.18	16.52	30.0	Pass
	5795	12.27	16.87	30.0	Pass



## 8. PEAK POWER SPECTRAL DENSITY TEST

### 8.1. Limits

In addition, the maximum power spectral density shall not exceed 11 dBm in any 1 megahertz band.

In addition, the maximum power spectral density shall not exceed 30 dBm in any 500 kHz band.

### 8.2. Test setup

1. Place the EUT on the table and set it in transmitting mode.
2. The testing follows FCC KDB 789033 D02 General UNII Test Procedures New Rules v01.
3. Remove the antenna from the EUT and then connect a low loss RF cable from the antenna port to

Spectrum.

4. For U-NII1, U-NII-2A, U-NII-2C Band:

Set RBW=1MHz, VBW=3MHz, where span is enough to capture the entire bandwidth, Sweep time = Auto (601 pts), detector = sample, traces 100 sweeps of video averaging. (SA-2 with the omission of procedure x, the integration with 26dB EBW bandwidth)

For U-NII-3 Band:

Set RBW=510 kHz, VBW=3\*RBW, where span is enough to capture the entire bandwidth, Sweep time = Auto (601 pts), detector = sample, traces 100 sweeps of video averaging. (SA-2 with the omission of procedure x, the integration with 26dB EBW bandwidth)

5. Use the cursor on spectrum to peak search the highest level of trace
6. Record the max. reading and add  $10 \log(1/\text{duty cycle})$ .

### 8.3. Test data

Test data as below

	Frequency (MHz)	Reading Level (dBm)	Duty factor (dB)	Duty factor 10 log (1MHz/RBW)	PPSD (dBm)	FCC Limit (dBm)	Result
802.11a	5180	1.93	0.21	0.0	2.14	11.00	Pass
	5220	2.46	0.21	0.0	2.67	11.00	Pass
	5240	1.33	0.21	0.0	1.54	11.00	Pass
	5745	1.66	0.21	0.0	1.87	30.00	Pass
	5785	2.17	0.21	0.0	2.38	30.00	Pass
	5825	1.85	0.21	0.0	2.06	30.00	Pass
802.11n (HT20)	5180	1.18	0.44	0.0	1.62	11.00	Pass
	5220	2.39	0.44	0.0	2.83	11.00	Pass
	5240	2.09	0.44	0.0	2.53	11.00	Pass
	5745	3.04	0.44	0.0	3.48	30.00	Pass
	5785	2.63	0.44	0.0	3.07	30.00	Pass
	5825	1.73	0.44	0.0	2.17	30.00	Pass
802.11n (HT40)	5190	-3.92	0.77	0.0	-3.15	11.00	Pass
	5230	-0.35	0.77	0.0	0.42	11.00	Pass
	5755	0.38	0.77	0.0	1.15	30.00	Pass
	5795	-0.59	0.77	0.0	0.18	30.00	Pass

Note: where x is the duty cycle.



802.11a 5180MHz



802.11a 5220MHz





802.11a 5240MHz



802.11a 5745MHz





802.11a 5785MHz



802.11a 5825MHz





802.11n(HT20) 5180MHz



802.11n(HT20) 5220MHz





802.11n(HT20) 5240MHz



802.11n(HT20) 5745MHz





802.11n(HT20) 5785MHz



802.11n(HT20) 5825MHz





802.11n(HT40) 5190MHz



802.11n(HT40) 5230MHz





802.11n(HT40) 5755MHz



802.11n(HT40) 5795MHz





## 9. DUTY CYCLE TEST SIGNAL

Pre-analysis Check: While conducting average power measurement, duty cycle of each mode shall be checked to ensure its duty cycle in order to compensate for the loss due to insufficient ratio of duty cycle.

All duty cycle is pre-scanned, and result as obtained below shows only the most representative ones where duty cycle is conducted as the given transmission with given virtual operation that expresses the percentage.

**Formula:**

$$\text{Duty Cycle} = \text{Ton} / (\text{Ton} + \text{Toff})$$

**Measurement Procedure:**

1. Set span = Zero
2. RBW = 8MHz
3. VBW = 8MHz,
4. Detector = Peak

Duty Cycle:

Operation Mode	Duty Cycle	Duty Fator (dB) $10 * \log (1/ \text{Duty cycle})$
802.11a	95.35%	0.21
802.11n(HT20)	90.78%	0.42
802.11n(HT40)	83.76%	0.77





## **10. FREQUENCY STABILITY**

### **10.1. Limits**

Manufacturers of U-NII devices are responsible for ensuring frequency stability such that an emission is maintained within the band of operation under all conditions of normal operation as specified in the user's manual.

### **10.2. Test setup**

1. The EUT was placed inside temperature chamber and powered and powered by nominal DC voltage.
2. Set EUT as normal operation.
3. Turn the EUT on and couple its output to spectrum.
4. Turn the EUT off and set the chamber to the highest temperature specified.
5. Allow sufficient time (approximately 30 min) for the temperature of the chamber to stabilize, turn the EUT and measure the operating frequency.
6. Repeat step with the temperature chamber set to the lowest temperature.







	Test Voltage	Test Temp.	Measured Frequency (MHz)	Spectrum Frequency (MHz)	$\Delta$ Frequency (MHz)
802.11n40	4.255V	-20°C	5190.000	5190.0268	-0.0268
			5230.000	5230.0364	-0.0364
			5755.000	5755.0517	-0.0517
			5795.000	5795.0641	-0.0641
	3.145V		5190.000	5190.0297	-0.0297
			5230.000	5230.0384	-0.0384
			5755.000	5755.0275	-0.0275
			5795.000	5795.0466	-0.0466
	3.70V	25°C	5190.000	5190.0258	-0.0258
			5230.000	5230.0618	-0.0618
			5755.000	5755.0268	-0.0268
			5795.000	5795.0517	-0.0517
	4.255V	50°C	5190.000	5190.0617	-0.0617
			5230.000	5230.0547	-0.0547
			5755.000	5755.0417	-0.0417
			5795.000	5795.0349	-0.0349
3.145V	50°C	5190.000	5190.0521	-0.0521	
		5230.000	5230.0329	-0.0329	
		5755.000	5755.0337	-0.0337	
		5795.000	5795.0419	-0.0419	



## **11. TRANSMISSION IN THE ABSENCE OF DATA**

### **11.1. Limits**

According to §15.407(c)

The device shall automatically discontinue transmission in case of either absence of information to transmit or operational failure. These provisions are not intended to preclude the transmission of control or signaling information or the use of repetitive codes used by certain digital technologies to complete frame or burst intervals. Applicants shall include in their application for equipment authorization a description of how this requirement is met.

### **11.2. Test result**

No non-compliance noted:

Refer to the theory of operation.

## 12. PHOTOGRAPHS OF TEST SET-UP

### Conducted Emission



### Radiated Emission Test

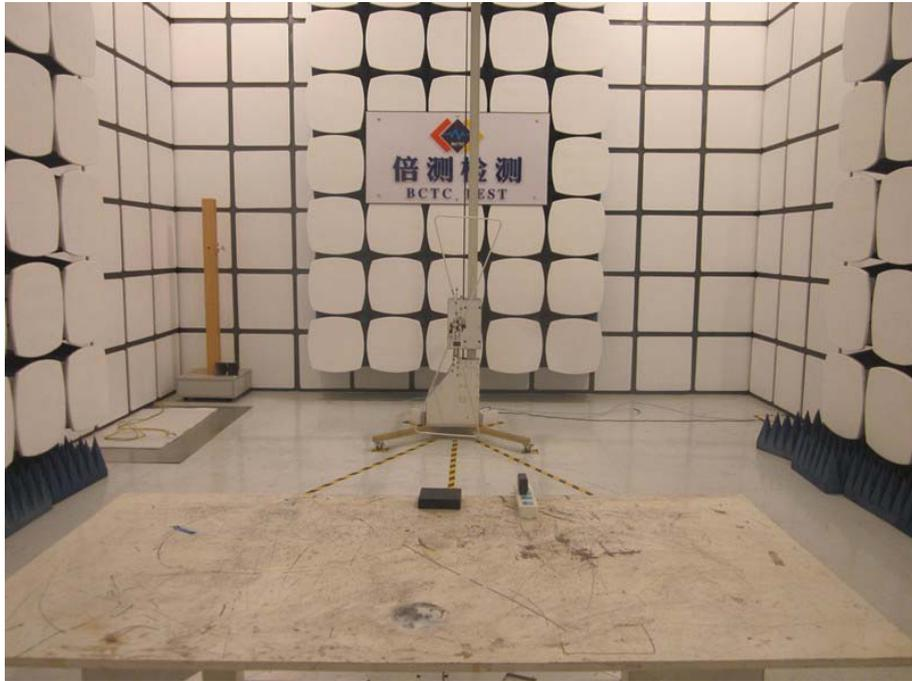

### 13. PHOTOGRAPHS OF THE EUT



-----END-----