

TEST REPORT

Product : HANDHELD VITALSIGNS
MONITORING SYSTEM
Trade mark : **bewell**
connect
Model/Type reference : BW-X07HD
Serial Number : N/A
Report Number : EED32100251307
FCC ID : 2AF8T-BW-X07HD
Date of Issue : Jun. 14, 2017
Test Standards : 47 CFR Part 2(2015)
47 CFR Part 27 subpart C(2015)
Test result : PASS

Prepared for:

BEWELL CONNECT CORP
SUITE 410, 185 ALEWIFE BROOK PARKWAY
CAMBRIDGE, Massachusetts, United States

Prepared by:

Centre Testing International Group Co., Ltd.
Hongwei Industrial Zone, Bao'an 70 District,
Shenzhen, Guangdong, China
TEL: +86-755-3368 3668
FAX: +86-755-3368 3385

Tested By:

Tom chen
Tom chen (Test Project)

Compiled by:

Kevin lan
Kevin lan (Project Engineer)

Reviewed by:

Kevin yang
Kevin yang (Reviewer)

Approved by:

Sheek Luo
Sheek Luo (Lab supervisor)

Date:

Jun. 14, 2017

Check No.: 2392125448



2 Version

Version No.	Date	Description
00	Jun. 14, 2017	Original

3 Test Summary

LTE Band 7			
Test Item	Test Requirement	Test method	Result
Conducted output power	Part 2.1046(a) /Part 27.50(h)	TIA-603-D-2010 & KDB 971168 D01v02r02	PASS
Effective Radiated Power of Transmitter(EIRP)	Part 2.1046(a) / Part 27.50(h)	TIA-603-D-2010 & KDB 971168 D01v02r02	PASS
peak-to-average ratio	Part 27.50(d)	KDB 971168 D01v02r02	PASS
99% & 26dB Occupied Bandwidth	Part 2.1049(h)	KDB 971168 D01v02r02	PASS
Band Edge at antenna terminals	Part 2.1051/ Part 27.53(m)	KDB 971168 D01v02r02	PASS
Spurious emissions at antenna terminals	Part 2.1051/ Part 27.53(m)	TIA-603-D-2010 & KDB 971168 D01v02r02	PASS
Field strength of spurious radiation	Part 2.1053/ Part 27.53(m)	TIA-603-D-2010 & KDB 971168 D01v02r02	PASS
Frequency stability	Part 2.1055/Part 27.54	TIA-603-D-2010 & KDB 971168 D01v02r02	PASS

Remark:The tested samples and the sample information are provided by the client.

4 Content

1 COVER PAGE	1
2 VERSION	2
3 TEST SUMMARY	3
4 CONTENT	4
5 TEST REQUIREMENT	5
5.1 TEST SETUP.....	5
5.1.1 For Conducted test setup.....	5
5.1.2 For Radiated Emissions test setup.....	5
5.2 TEST ENVIRONMENT.....	6
5.3 TEST CONDITION.....	6
6 GENERAL INFORMATION	7
6.1 CLIENT INFORMATION.....	7
6.2 GENERAL DESCRIPTION OF EUT.....	7
6.3 PRODUCT SPECIFICATION SUBJECTIVE TO THIS STANDARD.....	8
6.4 DESCRIPTION OF SUPPORT UNITS.....	8
6.5 TEST LOCATION.....	8
6.6 TEST FACILITY.....	8
6.7 DEVIATION FROM STANDARDS.....	8
6.8 ABNORMALITIES FROM STANDARD CONDITIONS.....	8
6.9 OTHER INFORMATION REQUESTED BY THE CUSTOMER.....	8
6.10 MEASUREMENT UNCERTAINTY (95% CONFIDENCE LEVELS, K=2).....	8
7 EQUIPMENT LIST	9
8 RADIO TECHNICAL REQUIREMENTS SPECIFICATION	11
APPENDIX A: CONDUCTED OUTPUT POWER AND EFFECTIVE (ISOTROPIC) RADIATED POWER.....	12
APPENDIX B: PEAK-TO-AVERAGE RATIO.....	18
APPENDIX C: 26DB BANDWIDTH AND OCCUPIED BANDWIDTH.....	79
APPENDIX D: BAND EDGE.....	89
APPENDIX E: CONDUCTED SPURIOUS EMISSION.....	127
APPENDIX F: FREQUENCY STABILITY.....	199
APPENDIX G: FIELD STRENGTH OF SPURIOUS RADIATION.....	207
PHOTOGRAPHS OF TEST SETUP	211
PHOTOGRAPHS OF EUT CONSTRUCTIONAL DETAILS	212

5 Test Requirement

5.1 Test setup

5.1.1 For Conducted test setup

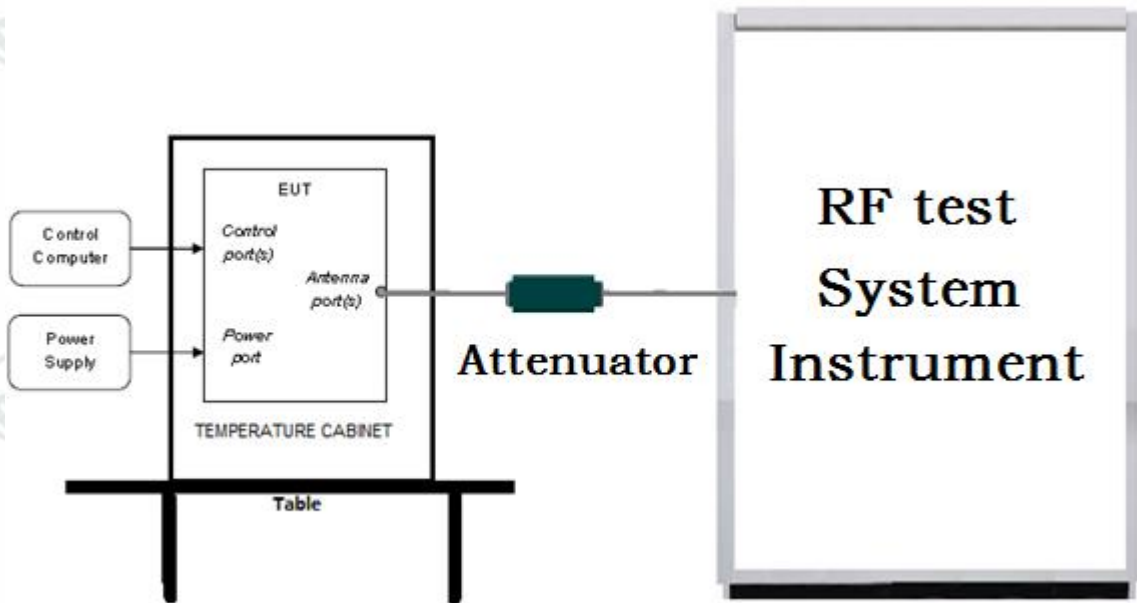

5.1.2 For Radiated Emissions test setup

Radiated Emissions setup:

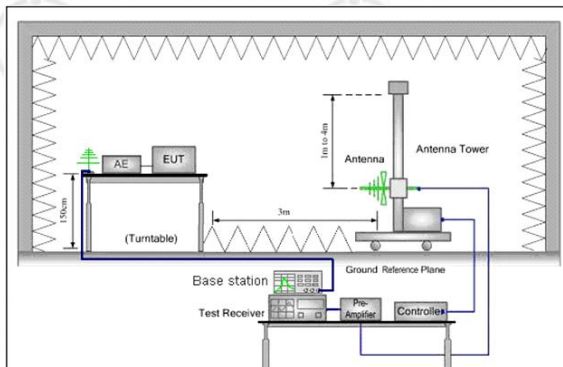

Figure 1.30MHz to 1GHz

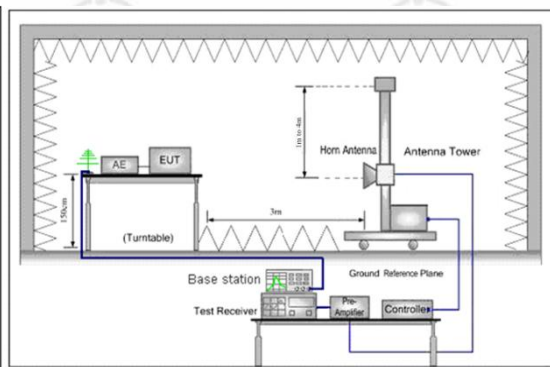

Figure 2. above 1GHz

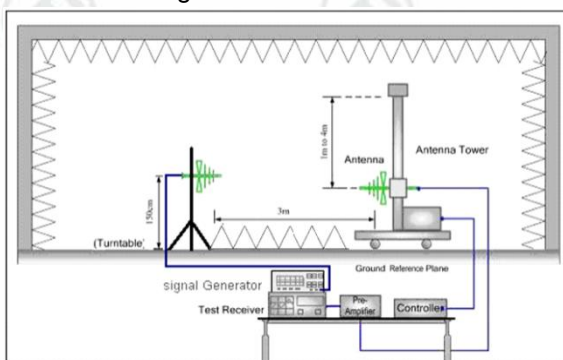

Figure 1. 30MHz to 1GHz

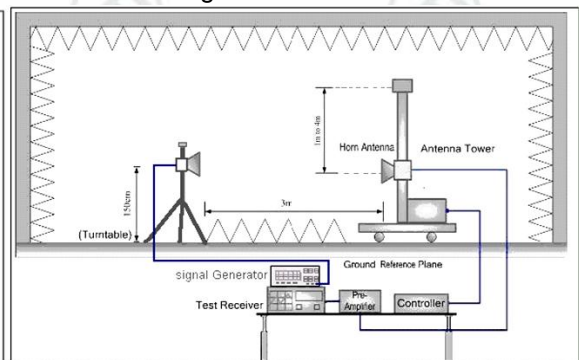

Figure 2. above 1GHz

5.2 Test Environment

Operating Environment:	
Temperature:	23°C
Humidity:	51% RH
Atmospheric Pressure:	1010mbar

5.3 Test Condition

Test channel:

LTE



Test Mode	Test Frequency ID	Bandwidth (MHz)	Number [UL]	Frequency of Uplink(MHz)	Number [DL]	Frequency of Downlink(MHz)
LTE band 7 TX:2500 MHz to 2570 MHz RX: :2620 MHz to 2690 MHz	Low Range	5	20775	2502.5	2775	2622.5
		10	20800	2505	2800	2625
		15	20825	2507.5	2825	2627.5
		20	20850	2510	2850	2630
	Mid Range	5/10/15/20	21100	2535	3100	2655
	High Range	5	21425	2567.5	3425	2687.5
		10	21400	2565	2400	2685
		15	21375	2562.5	3375	2682.5
		10	21350	2560	3350	2680

6 General Information

6.1 Client Information

Applicant:	BEWELL CONNECT CORP
Address of Applicant:	SUITE 410, 185 ALEWIFE BROOK PARKWAY CAMBRIDGE, Massachusetts, United States
Manufacturer:	Visiomed Technology Co., Ltd
Address of Manufacturer:	2 Floor of No.1 Building, Jia An Technological Industrial Park, 67 District, Bao An, 518101 Shenzhen China
Factory:	Visiomed Technology Co., Ltd
Address of Factory:	2 Floor of No.1 Building, Jia An Technological Industrial Park, 67 District, Bao An, 518101 Shenzhen China

6.2 General Description of EUT

Product Name:	HANDHELD VITALSIGNS MONITORING SYSTEM	
Test Model No.(EUT):	BW-X07HD	
Trade mark:		
EUT Supports Radios application:	<p>LTE Band 2: TX:1850 MHz to 1910 MHz RX:1930 MHz to 1990 MHz.</p> <p>LTE Band 4: TX:1710 MHz to 1755 MHz RX:2110 MHz to 2170 MHz.</p> <p>LTE band 7: TX:2500 MHz to 2570 MHz RX:2620 MHz to 2690 MHz.</p> <p>LTE band 12: TX: 699 MHz to 716 MHz RX: 729 MHz to 746 MHz.</p> <p>WCDMA1900: TX:1850 MHz to 1910 MHz RX:1930 MHz to 1990 MHz.</p> <p>WIFI 802.11b/g/n(20)/n(40): TX/RX:2412 MHz to 2462 MHz</p> <p>BT4.0 Dual mode: 2402 MHz to 2480 MHz.</p> <p>GPS:1575.42MHz</p>	
Power Supply:	AC adapter:	<p>MODEL No.:UE10WCP1-050200SPA</p> <p>PART No.:UE160106HKWY1-P</p> <p>INPUT:100-240V~50/60Hz, 500mA</p> <p>OUTPUT:5.0V  2.0A</p>
	Battery:	2500mAh 3.7V (Rechargeable Li-ion Battery)
Hardware Version:	(manufacturer declare)H.VS.MSM8909.02	
Software Version:	(manufacturer declare)Visiocheck_1.0.6	
Sample Received Date:	Oct. 19, 2016	
Sample tested Date:	Oct. 19, 2016 to Jun. 13, 2017	

6.3 Product Specification subjective to this standard

Frequency Band:	LTE Band 7: TX: 2500 MHz to 2570 MHz RX:2620 MHz to 2690 MHz
Modulation Type:	LTE Mode with QPSK,16QAM Modulation
Sample Type:	Portable production
Antenna Type:	Internal antenna
Antenna Gain:	LTE Band 7: 3dBi
Test Voltage:	AC 120V, 60Hz

6.4 Description of Support Units

The EUT has been tested independently.

6.5 Test Location

All tests were performed at:

Centre Testing International Group Co., Ltd.

Hongwei Industrial Zone, Bao'an 70 District, Shenzhen, Guangdong, China 518101

Telephone: +86 (0) 755 33683668 Fax:+86 (0) 755 33683385

No tests were sub-contracted.

6.6 Test Facility

FCC-Registration No.: 886427

Centre Testing International Group Co., Ltd. EMC Laboratory has been registered and fully described in a report filed with the FCC (Federal Communications Commission). The acceptance letter from the FCC is maintained in our files. Registration 886427.

6.7 Deviation from Standards

None.

6.8 Abnormalities from Standard Conditions

None.

6.9 Other Information Requested by the Customer

None.

6.10 Measurement Uncertainty (95% confidence levels, k=2)

No.	Item	Measurement Uncertainty
1	Radio Frequency	7.9×10^{-8}
2	RF power, conducted	0.31dB (30MHz-1GHz)
		0.57dB (1GHz-18GHz)
3	Radiated Spurious emission test	4.5dB (30MHz-1GHz)
		4.8dB (1GHz-12.75GHz)
4	Conduction emission	3.6dB (9kHz to 150kHz)
		3.2dB (150kHz to 30MHz)
5	Temperature test	0.64°C
6	Humidity test	2.8%
7	DC power voltages	0.025%

7 Equipment List

Communication RF test system					
Equipment	Manufacturer	Mode No.	Serial Number	Cal. Date (mm-dd-yyyy)	Cal. Due date (mm-dd-yyyy)
Spectrum Analyzer	Agilent	E4440A	MY46185649	12-16-2016	12-15-2017
Signal Generator	Agilent	E4438C	MY45095744	03-14-2017	03-13-2018
Communication test set	Agilent	E5515C	GB47050534	03-14-2017	03-13-2018
Signal Generator	Keysight	E8257D	MY53401106	03-14-2017	03-13-2018
Communication test set	R&S	CMW500	152394	03-14-2017	03-13-2018
High-pass filter	Sinoscite	FL3CX03WG18 NM12-0398-002	---	01-12-2017	01-11-2018
High-pass filter	MICRO-TRONICS	SPA-F-63029-4	---	01-12-2017	01-11-2018
band rejection filter	Sinoscite	FL5CX01CA09C L12-0395-001	---	01-12-2017	01-11-2018
band rejection filter	Sinoscite	FL5CX01CA08C L12-0393-001	---	01-12-2017	01-11-2018
band rejection filter	Sinoscite	FL5CX02CA04C L12-0396-002	---	01-12-2017	01-11-2018
band rejection filter	Sinoscite	FL5CX02CA03C L12-0394-001	---	01-12-2017	01-11-2018
DC Power	Keysight	E3642A	MY54426112	03-14-2017	03-13-2018
DC Power	Keysight	E3642A	MY54426115	03-14-2017	03-13-2018
PC-2	Lenovo	R4960d	---	04-01-2017	03-31-2018
PC-3	Lenovo	R4960d	---	04-01-2017	03-31-2018
RF control unit	JS Tonscend	JS0806-1	158060004	03-14-2017	03-13-2018
DC power Box	JS Tonscend	JS0806-4	158060007	04-01-2017	03-31-2018
LTE Automatic test software	JS Tonscend	JS1120-1	---	04-01-2017	03-31-2018
WCDMA Automatic test software	JS Tonscend	JS1120-3	---	04-01-2017	03-31-2018
GSM Automatic test software	JS Tonscend	JS1120-3	---	04-01-2017	03-31-2018

Radiated Spurious Emission & Radiated Emission					
Equipment	Manufacturer	Mode No.	Serial Number	Cal. date (mm-dd-yyyy)	Cal. Due date (mm-dd-yyyy)
3M Chamber & Accessory Equipment	TDK	SAC-3	---	06-05-2016	06-05-2019
TRILOG Broadband Antenna	SCHWARZBECK	VULB9163	9163-618	07-28-2016	07-27-2017
Microwave Preamplifier	Agilent	8449B	3008A02425	02-16-2017	02-15-2018
Horn Antenna	ETS-LINDGREN	3117	00057407	07-20-2015	07-18-2018
Loop Antenna	ETS	6502	00071730	07-30-2015	07-28-2017
Spectrum Analyzer	R&S	FSP40	100416	06-16-2016	06-15-2017
Receiver	R&S	ESCI	100435	06-16-2016	06-15-2017
Multi device Controller	matturo	NCD/070/10711 112	---	01-12-2017	01-11-2018
LISN	schwarzbeck	NNBM8125	81251547	06-16-2016	06-15-2017
LISN	schwarzbeck	NNBM8125	81251548	06-16-2016	06-15-2017
Signal Generator	Agilent	E4438C	MY45095744	03-14-2017	03-13-2018
Signal Generator	Keysight	E8257D	MY53401106	03-14-2017	03-13-2018
Temperature/ Humidity Indicator	TAYLOR	1451	1905	05-08-2017	05-07-2018
Communication test set	Agilent	E5515C	GB47050534	03-14-2017	03-13-2018
Cable line	Fulai(7M)	SF106	5219/6A	01-12-2017	01-11-2018
Cable line	Fulai(6M)	SF106	5220/6A	01-12-2017	01-11-2018
Cable line	Fulai(3M)	SF106	5216/6A	01-12-2017	01-11-2018
Cable line	Fulai(3M)	SF106	5217/6A	01-12-2017	01-11-2018
Communication test set	R&S	CMW500	152394	03-14-2017	03-13-2018
High-pass filter(3-18GHz)	Sinoscite	FL3CX03WG18 NM12-0398-002	---	01-12-2017	01-11-2018
High-pass filter(6-18GHz)	MICRO-TRONICS	SPA-F-63029-4	---	01-12-2017	01-11-2018
band rejection filter	Sinoscite	FL5CX01CA09C L12-0395-001	---	01-12-2017	01-11-2018
band rejection filter	Sinoscite	FL5CX01CA08C L12-0393-001	---	01-12-2017	01-11-2018
band rejection filter	Sinoscite	FL5CX02CA04C L12-0396-002	---	01-12-2017	01-11-2018
band rejection filter	Sinoscite	FL5CX02CA03C L12-0394-001	---	01-12-2017	01-11-2018

8 Radio Technical Requirements Specification

Reference documents for testing:

No.	Identity	Document Title
1	PART 27 (2015)	PART 27 – MISCELLANEOUS WIRELESS COMMUNICATIONS SERVICES Subpart C – Technical Standards
2	PART 2 (2015)	Frequency allocations and radio treaty matters; general rules and regulations
3	TIA-603-D-2010	Land Mobile FM or PM -Communications Equipment -Measurement and Performance Standards
4	KDB971168 D01	KDB971168 D01 Power Meas License Digital Systems v02r02
5	KDB 412172 D01	KDB 412172 D01 Determining ERP and EIRP v01r01

Test Results List:

Test Requirement	Test method	Test item	Verdict	Note
Part 2.1046(a)/ Part 27.50(h)	TIA-603-D&KDB 971168 D01v02r02	Conducted output power	PASS	Appendix A)
Part 27.50(d)	KDB 971168 D01v02r02	peak-to-average ratio	PASS	Appendix B)
Part 2.1049(h)	KDB 971168 D01v02r02	99% & 26dB Occupied Bandwidth	PASS	Appendix C)
Part 2.1051/ Part 27.53(m)	Part 27.53(m) &KDB 971168 D01v02r02	Band Edge at antenna terminals	PASS	Appendix D)
Part 2.1051 / Part 27.53(m)	TIA-603-D &KDB 971168 D01v02r02	Spurious emissions at antenna terminals	PASS	Appendix E)
Part 2.1055/ Part 27.54	TIA-603-D &KDB 971168 D01v02r02	Frequency stability	PASS	Appendix F)
Part 2.1053 / Part 27.53(m)	TIA-603-D &KDB 971168 D01v02r02	Field strength of spurious radiation	PASS	Appendix G)
Part 2.1046(a)/ Part 27.50(h)	TIA-603-D &KDB 971168 D01v02r02	Effective Radiated Power of Transmitter(ERP)	PASS	Appendix A)

Appendix A: Conducted Output Power and Effective (Isotropic) Radiated Power

<p>Description of the Conducted Output Power Measurement and ERP/EIRP Measurement:</p>	<p>A system simulator was used to establish communication with the EUT. Its parameters were set to force the EUT transmitting at maximum output power. The measured power in the radio frequency on the transmitter output terminals shall be reported.</p> <p>According to KDB 412172 D01 Power Approach $EIRP = P_T + G_T - L_c$, $ERP = EIRP - 2.15$, where P_T = transmitter output power in dBm G_T = gain of the transmitting antenna in dBi L_c = signal attenuation in the connecting cable between the transmitter and antenna in dB</p>				
<p>Measurement Procedure:</p>	<ol style="list-style-type: none"> 1. The transmitter output port was connected to the system simulator. 2. Set EUT at maximum power through the system simulator. 3. Select lowest, middle, and highest channels for each band and different modulation. 4. Measure and record the power level from the system simulator. 				
<p>Limit:</p>	<table border="1"> <tr> <td data-bbox="422 891 598 936">Mode</td> <td data-bbox="606 891 1056 936">LTE band 7</td> </tr> <tr> <td data-bbox="422 936 598 981">Limit</td> <td data-bbox="606 936 1056 981">33.01dBm (2W)</td> </tr> </table>	Mode	LTE band 7	Limit	33.01dBm (2W)
Mode	LTE band 7				
Limit	33.01dBm (2W)				

Test Result

$G_T - L_C = 3\text{dB}$

Channel Bandwidth: 5 MHz

Channel Bandwidth: 5 MHz							
Modulation	Channel	RB Configuration		Average Power [dBm]	E.i.r.p [dBm]	Verdict	
		Size	Offset				
QPSK	LCH	1	0	22.80	25.80	PASS	
		1	12	22.87	25.87	PASS	
		1	24	23.07	26.07	PASS	
		12	0	21.93	24.93	PASS	
		12	6	21.80	24.80	PASS	
		12	13	22.04	25.04	PASS	
		25	0	21.90	24.90	PASS	
	MCH	1	0	22.82	25.82	PASS	
		1	12	22.60	25.60	PASS	
		1	24	22.67	25.67	PASS	
		12	0	21.99	24.99	PASS	
		12	6	21.95	24.95	PASS	
		12	13	22.10	25.10	PASS	
		25	0	21.93	24.93	PASS	
	HCH	1	0	22.52	25.52	PASS	
		1	12	21.83	24.83	PASS	
		1	24	21.75	24.75	PASS	
		12	0	21.93	24.93	PASS	
		12	6	21.69	24.69	PASS	
		12	13	21.53	24.53	PASS	
		25	0	21.79	24.79	PASS	
	16QAM	LCH	1	0	22.10	25.10	PASS
			1	12	21.81	24.81	PASS
			1	24	22.08	25.08	PASS
12			0	21.02	24.02	PASS	
12			6	20.89	23.89	PASS	
12			13	20.98	23.98	PASS	
25			0	21.09	24.09	PASS	
MCH		1	0	22.09	25.09	PASS	
		1	12	21.98	24.98	PASS	
		1	24	22.08	25.08	PASS	
		12	0	21.13	24.13	PASS	

	HCH	12	6	21.06	24.06	PASS
		12	13	20.95	23.95	PASS
		25	0	21.15	24.15	PASS
		1	0	21.81	24.81	PASS
		1	12	21.28	24.28	PASS
		1	24	21.26	24.26	PASS
		12	0	21.24	24.24	PASS
		12	6	21.00	24.00	PASS
		12	13	20.89	23.89	PASS
		25	0	21.08	24.08	PASS

Channel Bandwidth: 10 MHz

Channel Bandwidth: 10 MHz							
Modulation	Channel	RB Configuration		Average Power [dBm]	E.i.r.p [dBm]	Verdict	
		Size	Offset				
QPSK	LCH	1	0	22.86	25.86	PASS	
		1	24	23.02	26.02	PASS	
		1	49	23.12	26.12	PASS	
		25	0	22.03	25.03	PASS	
		25	12	22.11	25.11	PASS	
		25	25	22.06	25.06	PASS	
		50	0	21.99	24.99	PASS	
		MCH	1	0	22.81	25.81	PASS
	1		24	22.52	25.52	PASS	
	1		49	22.14	25.14	PASS	
	25		0	22.19	25.19	PASS	
	25		12	22.10	25.10	PASS	
	25		25	22.14	25.14	PASS	
	50		0	21.93	24.93	PASS	
	HCH		1	0	22.92	25.92	PASS
		1	24	22.05	25.05	PASS	
		1	49	21.15	24.15	PASS	
		25	0	22.33	25.33	PASS	
		25	12	21.92	24.92	PASS	
		25	25	21.45	24.45	PASS	
		50	0	22.00	25.00	PASS	
		16QAM	LCH	1	0	22.30	25.30
	1			24	22.30	25.30	PASS

		1	49	22.76	25.76	PASS	
		25	0	21.06	24.06	PASS	
		25	12	21.08	24.08	PASS	
		25	25	21.02	24.02	PASS	
		50	0	21.02	24.02	PASS	
	MCH		1	0	22.33	25.33	PASS
			1	24	22.03	25.03	PASS
			1	49	21.71	24.71	PASS
			25	0	21.07	24.07	PASS
			25	12	21.04	24.04	PASS
			25	25	21.15	24.15	PASS
			50	0	21.08	24.08	PASS
			HCH		1	0	22.51
	1	24			21.64	24.64	PASS
	1	49			20.72	23.72	PASS
	25	0			21.32	24.32	PASS
	25	12			21.16	24.16	PASS
	25	25			20.76	23.76	PASS
	50	0			21.34	24.34	PASS

Channel Bandwidth: 15 MHz

Channel Bandwidth: 15 MHz							
Modulation	Channel	RB Configuration		Average Power [dBm]	E.i.r.p [dBm]	Verdict	
		Size	Offset				
QPSK	LCH	1	0	23.22	26.22	PASS	
		1	37	23.10	26.10	PASS	
		1	74	22.98	25.98	PASS	
		37	0	21.91	24.91	PASS	
		37	18	21.99	24.99	PASS	
		37	38	21.96	24.96	PASS	
		75	0	21.76	24.76	PASS	
	MCH		1	0	23.11	26.11	PASS
			1	37	22.36	25.36	PASS
			1	74	22.57	25.57	PASS
			37	0	22.03	25.03	PASS
			37	18	21.97	24.97	PASS
			37	38	22.06	25.06	PASS
			75	0	21.97	24.97	PASS

16QAM	HCH	1	0	22.40	25.40	PASS
		1	37	22.16	25.16	PASS
		1	74	21.45	24.45	PASS
		37	0	22.17	25.17	PASS
		37	18	21.93	24.93	PASS
		37	38	21.72	24.72	PASS
		75	0	21.22	24.22	PASS
	LCH	1	0	22.75	25.75	PASS
		1	37	23.19	26.19	PASS
		1	74	22.77	25.77	PASS
		37	0	20.87	23.87	PASS
		37	18	21.01	24.01	PASS
		37	38	20.96	23.96	PASS
		75	0	20.82	23.82	PASS
	MCH	1	0	22.89	25.89	PASS
		1	37	21.51	24.51	PASS
		1	74	20.68	23.68	PASS
		37	0	21.20	24.20	PASS
		37	18	21.11	24.11	PASS
		37	38	21.13	24.13	PASS
		75	0	21.11	24.11	PASS
	HCH	1	0	22.15	25.15	PASS
		1	37	21.76	24.76	PASS
		1	74	21.08	24.08	PASS
		37	0	21.28	24.28	PASS
		37	18	20.89	23.89	PASS
		37	38	21.11	24.11	PASS
		75	0	21.41	24.41	PASS

Channel Bandwidth: 20 MHz

Channel Bandwidth: 20 MHz						
Modulation	Channel	RB Configuration		Average Power [dBm]	E.i.r.p [dBm]	Verdict
		Size	Offset			
QPSK	LCH	1	0	22.99	25.99	PASS
		1	49	22.19	25.19	PASS
		1	99	22.80	25.80	PASS
		50	0	21.93	24.93	PASS
		50	25	21.99	24.99	PASS

		50	50	21.73	24.73	PASS	
		100	0	21.79	24.79	PASS	
	MCH	1	0	23.02	26.02	PASS	
		1	49	22.47	25.47	PASS	
		1	99	22.68	25.68	PASS	
		50	0	21.99	24.99	PASS	
		50	25	21.99	24.99	PASS	
		50	50	22.13	25.13	PASS	
		100	0	21.97	24.97	PASS	
		HCH	1	0	22.40	25.40	PASS
	1		49	22.71	25.71	PASS	
	1		99	21.08	24.08	PASS	
	50		0	21.30	24.30	PASS	
	50		25	21.83	24.83	PASS	
	50		50	21.85	24.85	PASS	
	100		0	21.22	24.22	PASS	
	16QAM		LCH	1	0	21.89	24.89
		1		49	22.19	25.19	PASS
		1		99	21.58	24.58	PASS
		50		0	20.98	23.98	PASS
50		25		20.98	23.98	PASS	
50		50		20.75	23.75	PASS	
100		0		20.84	23.84	PASS	
MCH		1		0	22.23	25.23	PASS
		1	49	21.63	24.63	PASS	
		1	99	22.01	25.01	PASS	
		50	0	21.07	24.07	PASS	
		50	25	21.04	24.04	PASS	
		50	50	21.15	24.15	PASS	
HCH		100	0	21.08	24.08	PASS	
	1	0	22.56	25.56	PASS		
	1	49	21.32	24.32	PASS		
	1	99	20.47	23.47	PASS		
	50	0	21.38	24.38	PASS		
	50	25	20.85	23.85	PASS		
	50	50	21.14	24.14	PASS		
	100	0	21.22	24.22	PASS		

Appendix B: Peak-to-Average Ratio

Test Result

Channel Bandwidth: 5 MHz

Channel Bandwidth: 5 MHz						
Modulation	Channel	RB Configuration		Peak-to-Average Ratio [dB]	Limit [dB]	Verdict
		Size	Offset			
QPSK	LCH	1	0	8.38	<13	PASS
		1	12	3.47	<13	PASS
		1	24	3.46	<13	PASS
		12	0	4.24	<13	PASS
		12	6	4.19	<13	PASS
		12	13	4.23	<13	PASS
		25	0	4.76	<13	PASS
	MCH	1	0	3.99	<13	PASS
		1	12	3.92	<13	PASS
		1	24	3.98	<13	PASS
		12	0	4.54	<13	PASS
		12	6	4.46	<13	PASS
		12	13	4.47	<13	PASS
		25	0	5	<13	PASS
	HCH	1	0	3.95	<13	PASS
		1	12	3.84	<13	PASS
		1	24	5.67	<13	PASS
		12	0	4.35	<13	PASS
		12	6	4.15	<13	PASS
		12	13	4.29	<13	PASS
		25	0	4.75	<13	PASS
16QAM	LCH	1	0	4.5	<13	PASS
		1	12	4.48	<13	PASS
		1	24	4.39	<13	PASS
		12	0	5.28	<13	PASS
		12	6	5.19	<13	PASS
		12	13	5.29	<13	PASS
		25	0	12.09	<13	PASS
	MCH	1	0	4.88	<13	PASS
		1	12	4.87	<13	PASS
		1	24	4.82	<13	PASS
		12	0	5.46	<13	PASS

	HCH	12	6	5.36	<13	PASS
		12	13	5.48	<13	PASS
		25	0	5.8	<13	PASS
		1	0	4.59	<13	PASS
		1	12	4.49	<13	PASS
		1	24	5.17	<13	PASS
		12	0	5.33	<13	PASS
		12	6	5.27	<13	PASS
		12	13	5.15	<13	PASS
		25	0	5.43	<13	PASS

Channel Bandwidth: 10 MHz

Channel Bandwidth: 10 MHz						
Modulation	Channel	RB Configuration		Peak-to-Average Ratio [dB]	Limit [dB]	Verdict
		Size	Offset			
QPSK	LCH	1	0	4.1	<13	PASS
		1	24	4.6	<13	PASS
		1	49	4.39	<13	PASS
		25	0	4.27	<13	PASS
		25	12	4.64	<13	PASS
		25	25	4.38	<13	PASS
		50	0	4.86	<13	PASS
		50	0	4.86	<13	PASS
	MCH	1	0	3.99	<13	PASS
		1	24	3.87	<13	PASS
		1	49	4.27	<13	PASS
		25	0	4.49	<13	PASS
		25	12	4.77	<13	PASS
		25	25	4.53	<13	PASS
		50	0	4.79	<13	PASS
		50	0	4.79	<13	PASS
	HCH	1	0	3.93	<13	PASS
		1	24	3.66	<13	PASS
		1	49	5.3	<13	PASS
		25	0	4.37	<13	PASS
		25	12	4.67	<13	PASS
		25	25	4.47	<13	PASS
		50	0	4.59	<13	PASS
		50	0	4.59	<13	PASS
16QAM	LCH	1	0	4.37	<13	PASS
		1	24	5.41	<13	PASS

		1	49	4.61	<13	PASS
		25	0	5.38	<13	PASS
		25	12	5.51	<13	PASS
		25	25	5.53	<13	PASS
		50	0	5.85	<13	PASS
	MCH	1	0	5.09	<13	PASS
		1	24	4.38	<13	PASS
		1	49	4.87	<13	PASS
		25	0	5.54	<13	PASS
		25	12	5.71	<13	PASS
		25	25	5.59	<13	PASS
		50	0	5.89	<13	PASS
		HCH	1	0	4.56	<13
	1		24	4.38	<13	PASS
	1		49	6.72	<13	PASS
	25		0	8.51	<13	PASS
	25		12	5.59	<13	PASS
	25		25	5.52	<13	PASS
	50		0	5.79	<13	PASS

Channel Bandwidth: 15 MHz

Channel Bandwidth: 15 MHz						
Modulation	Channel	RB Configuration		Peak-to-Average Ratio [dB]	Limit [dB]	Verdict
		Size	Offset			
QPSK	LCH	1	0	5.38	<13	PASS
		1	37	4.14	<13	PASS
		1	74	6.39	<13	PASS
		37	0	5.02	<13	PASS
		37	18	5.09	<13	PASS
		37	38	5.08	<13	PASS
		75	0	5.54	<13	PASS
		MCH	1	0	5.48	<13
	1		37	3.85	<13	PASS
	1		74	6.63	<13	PASS
	37		0	5.06	<13	PASS
	37		18	5.26	<13	PASS
	37		38	5.2	<13	PASS
	75		0	5.46	<13	PASS

16QAM	HCH	1	0	5.16	<13	PASS	
		1	37	4.13	<13	PASS	
		1	74	5.49	<13	PASS	
		37	0	5.01	<13	PASS	
		37	18	5.23	<13	PASS	
		37	38	5.23	<13	PASS	
		75	0	5.35	<13	PASS	
	LCH	1	0	5.78	<13	PASS	
		1	37	4.86	<13	PASS	
		1	74	6.59	<13	PASS	
		37	0	6.18	<13	PASS	
		37	18	5.88	<13	PASS	
		37	38	6.16	<13	PASS	
		75	0	6.53	<13	PASS	
		MCH	1	0	8.43	<13	PASS
			1	37	4.87	<13	PASS
			1	74	6.09	<13	PASS
			37	0	6.25	<13	PASS
			37	18	6	<13	PASS
			37	38	6.4	<13	PASS
			75	0	6.59	<13	PASS
	HCH	1	0	5.86	<13	PASS	
		1	37	4.87	<13	PASS	
		1	74	6.09	<13	PASS	
		37	0	6.18	<13	PASS	
		37	18	5.99	<13	PASS	
		37	38	6.21	<13	PASS	
		75	0	8.57	<13	PASS	

Channel Bandwidth: 20 MHz

Channel Bandwidth: 20 MHz						
Modulation	Channel	RB Configuration		Peak-to-Average Ratio [dB]	Limit [dB]	Verdict
		Size	Offset			
QPSK	LCH	1	0	2.49	<13	PASS
		1	49	4.33	<13	PASS
		1	99	3.37	<13	PASS
		50	0	5.86	<13	PASS
		50	25	5.02	<13	PASS

		50	50	6.14	<13	PASS	
		100	0	6.17	<13	PASS	
	MCH	1	0	3.38	<13	PASS	
		1	49	4.13	<13	PASS	
		1	99	2.91	<13	PASS	
		50	0	5.82	<13	PASS	
		50	25	4.93	<13	PASS	
		50	50	6.12	<13	PASS	
		100	0	6.14	<13	PASS	
		HCH	1	0	2.85	<13	PASS
	1		49	4.21	<13	PASS	
	1		99	3.34	<13	PASS	
	50		0	5.75	<13	PASS	
	50		25	4.88	<13	PASS	
	50		50	6.05	<13	PASS	
	100		0	6.02	<13	PASS	
	16QAM		LCH	1	0	2.89	<13
		1		49	5.01	<13	PASS
		1		99	3.55	<13	PASS
		50		0	6.68	<13	PASS
50		25		5.99	<13	PASS	
50		50		6.92	<13	PASS	
100		0		7.04	<13	PASS	
MCH		1		0	3.44	<13	PASS
		1	49	4.99	<13	PASS	
		1	99	3.26	<13	PASS	
		50	0	6.75	<13	PASS	
		50	25	6.05	<13	PASS	
		50	50	6.85	<13	PASS	
HCH		100	0	6.99	<13	PASS	
	1	0	3.14	<13	PASS		
	1	49	4.88	<13	PASS		
	1	99	2.85	<13	PASS		
	50	0	6.67	<13	PASS		
	50	25	5.96	<13	PASS		
	50	50	6.73	<13	PASS		
	100	0	6.92	<13	PASS		

Test Graphs

Channel Bandwidth: 5 MHz



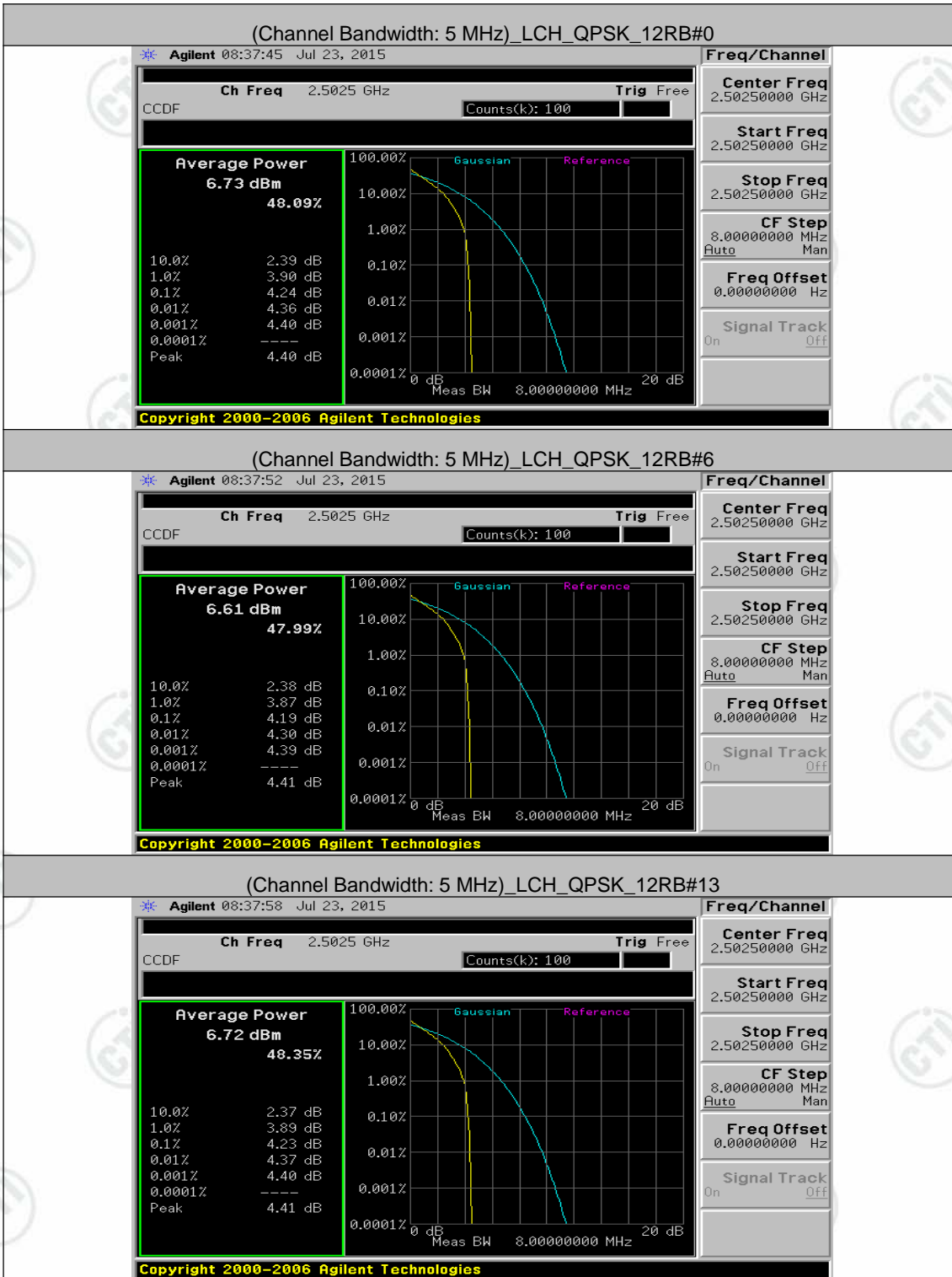

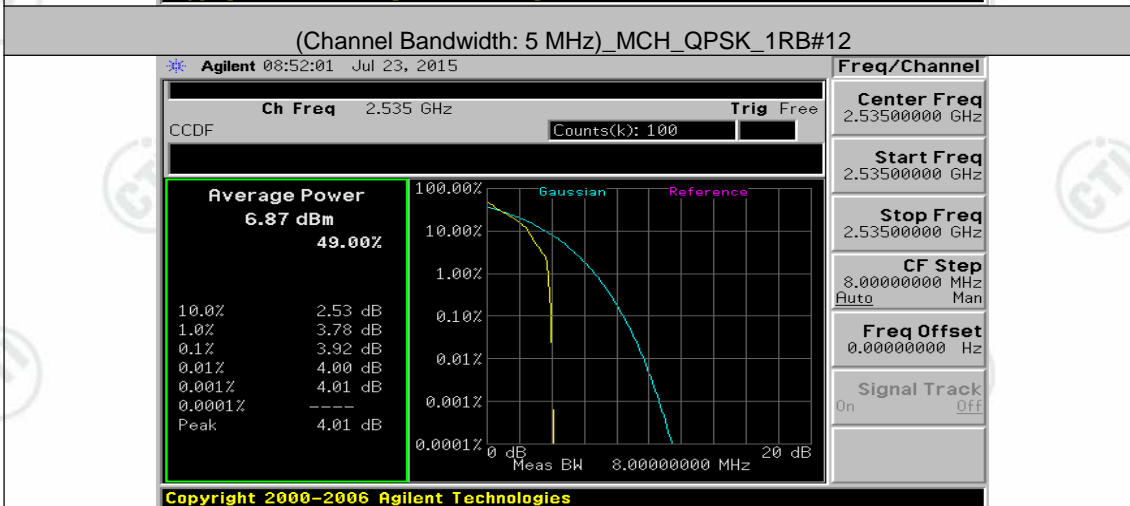
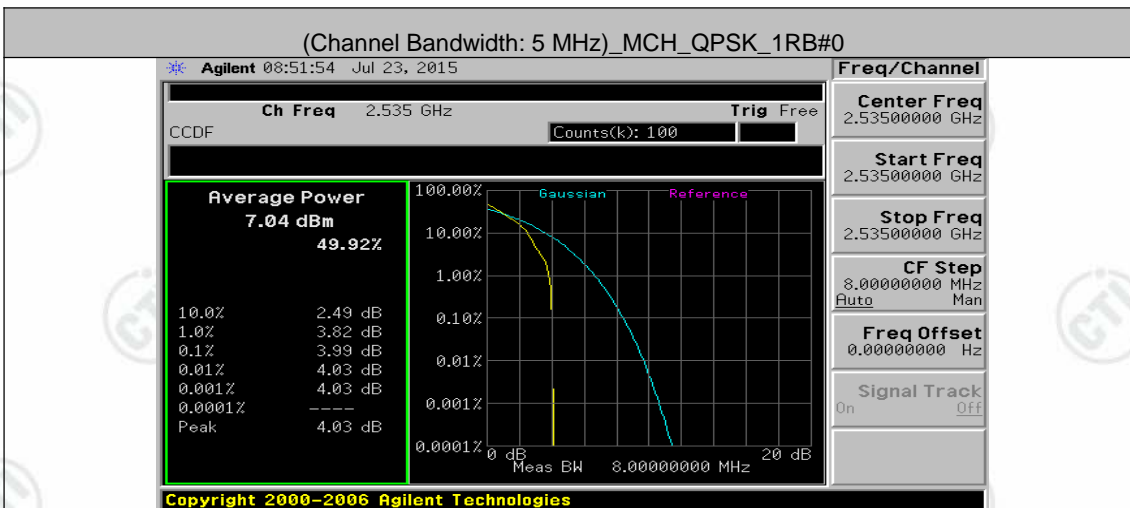
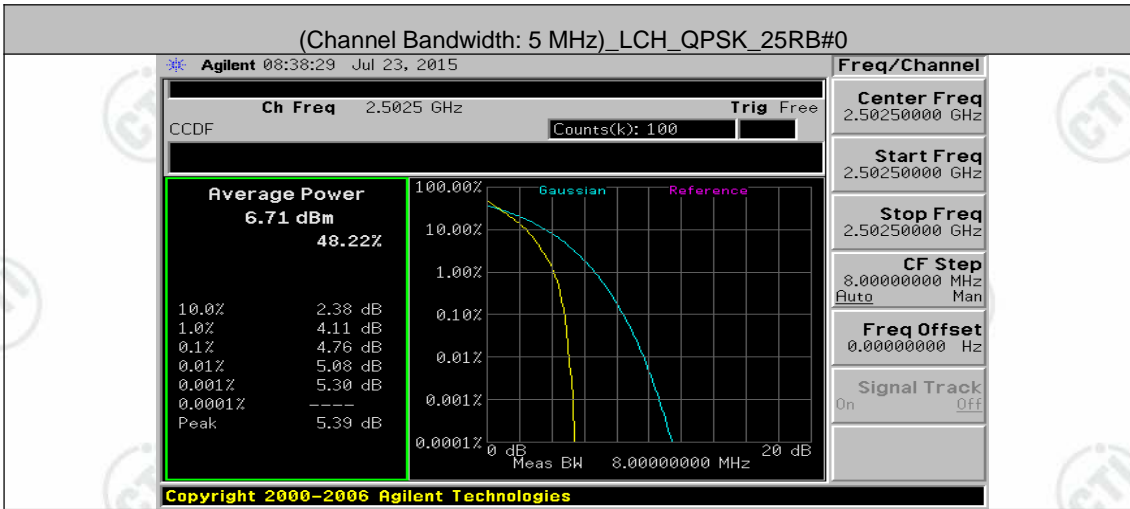



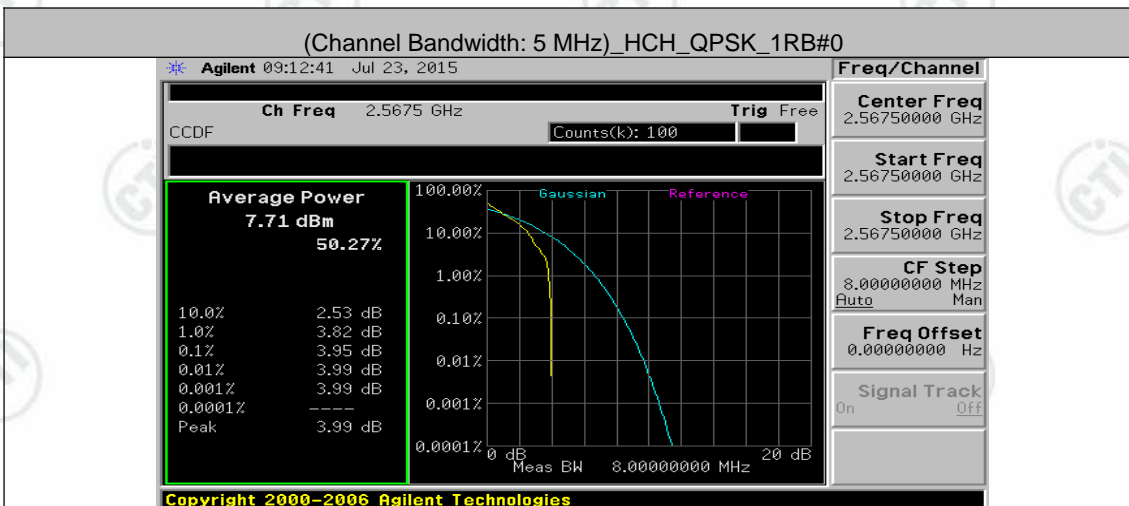
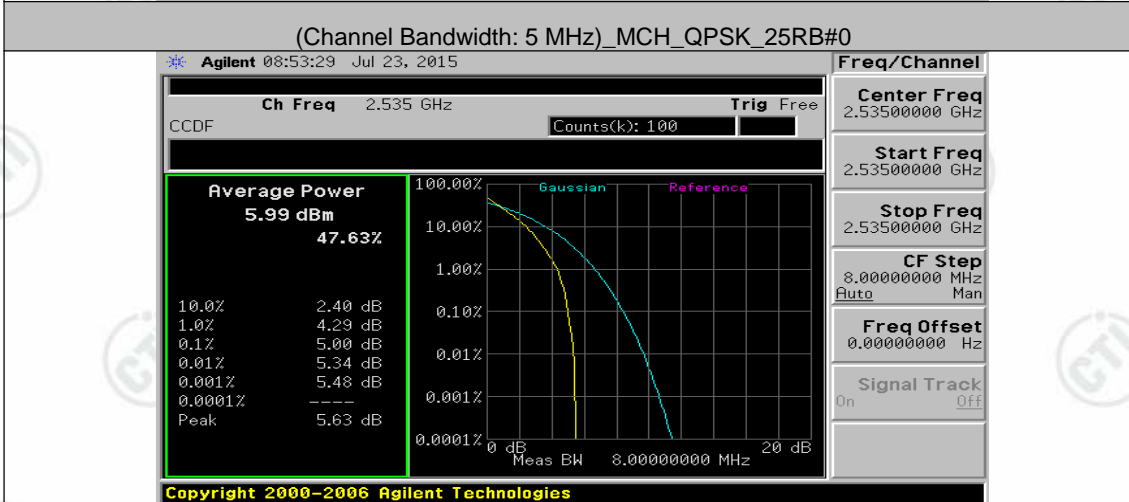
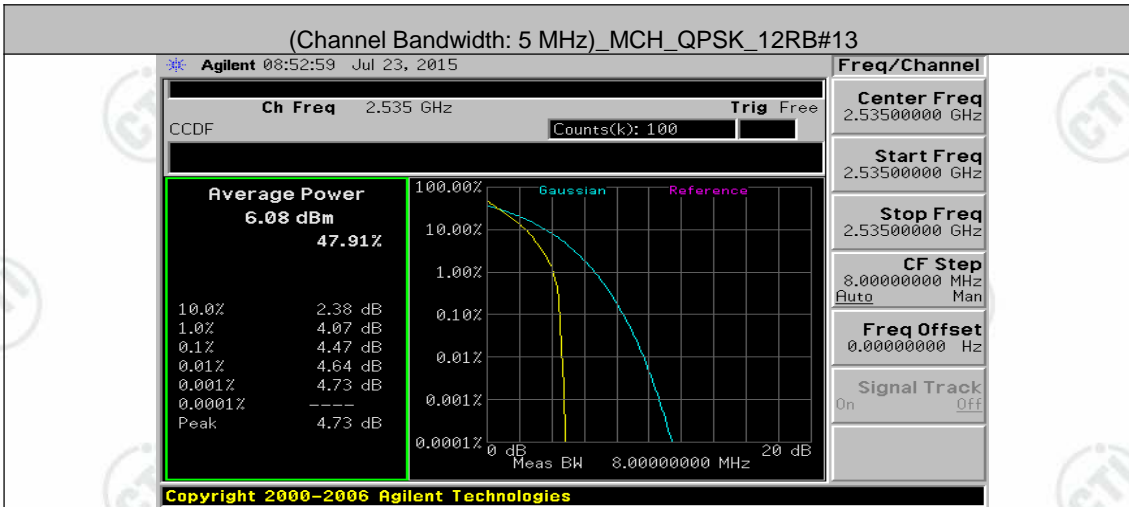





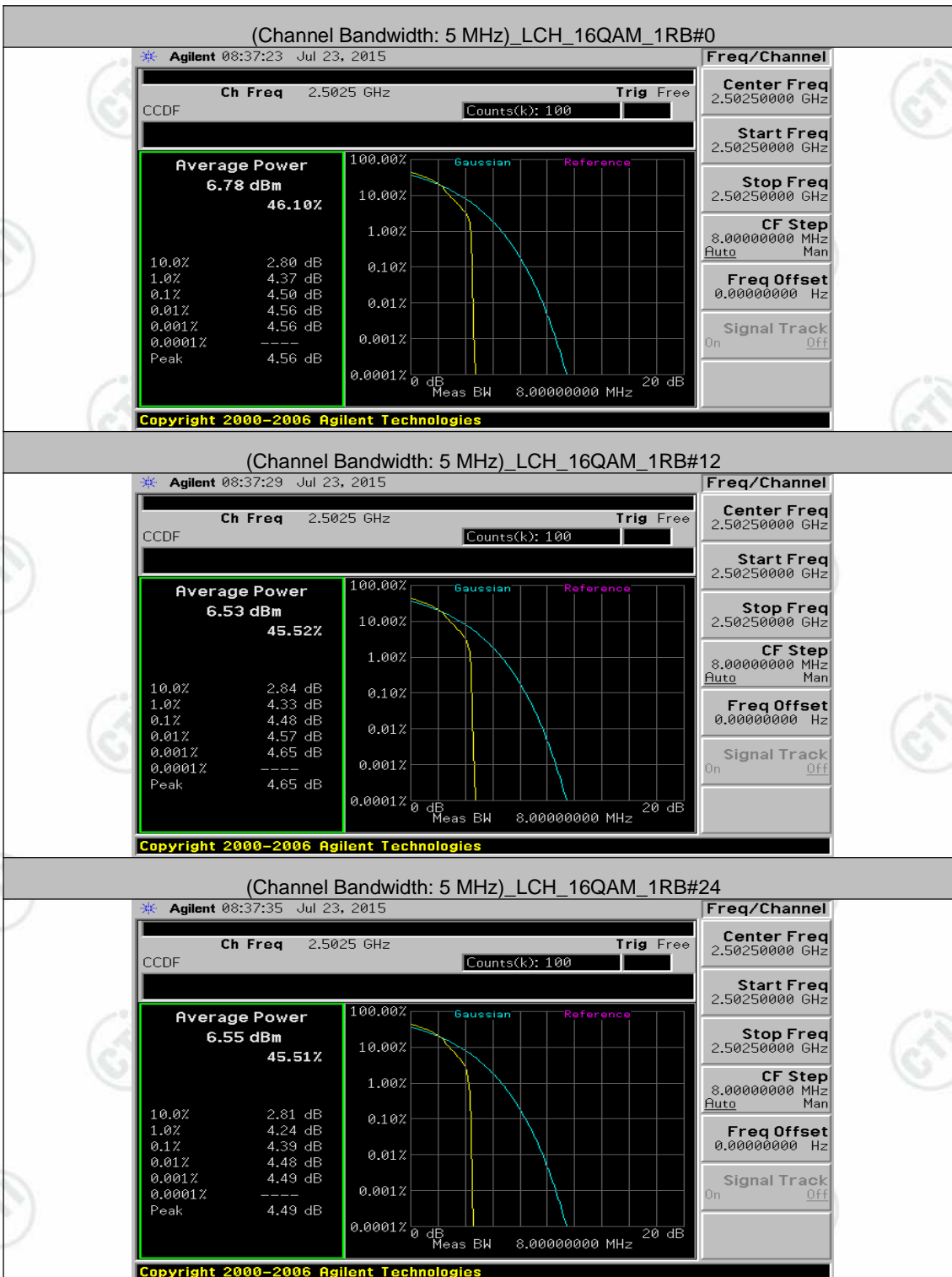

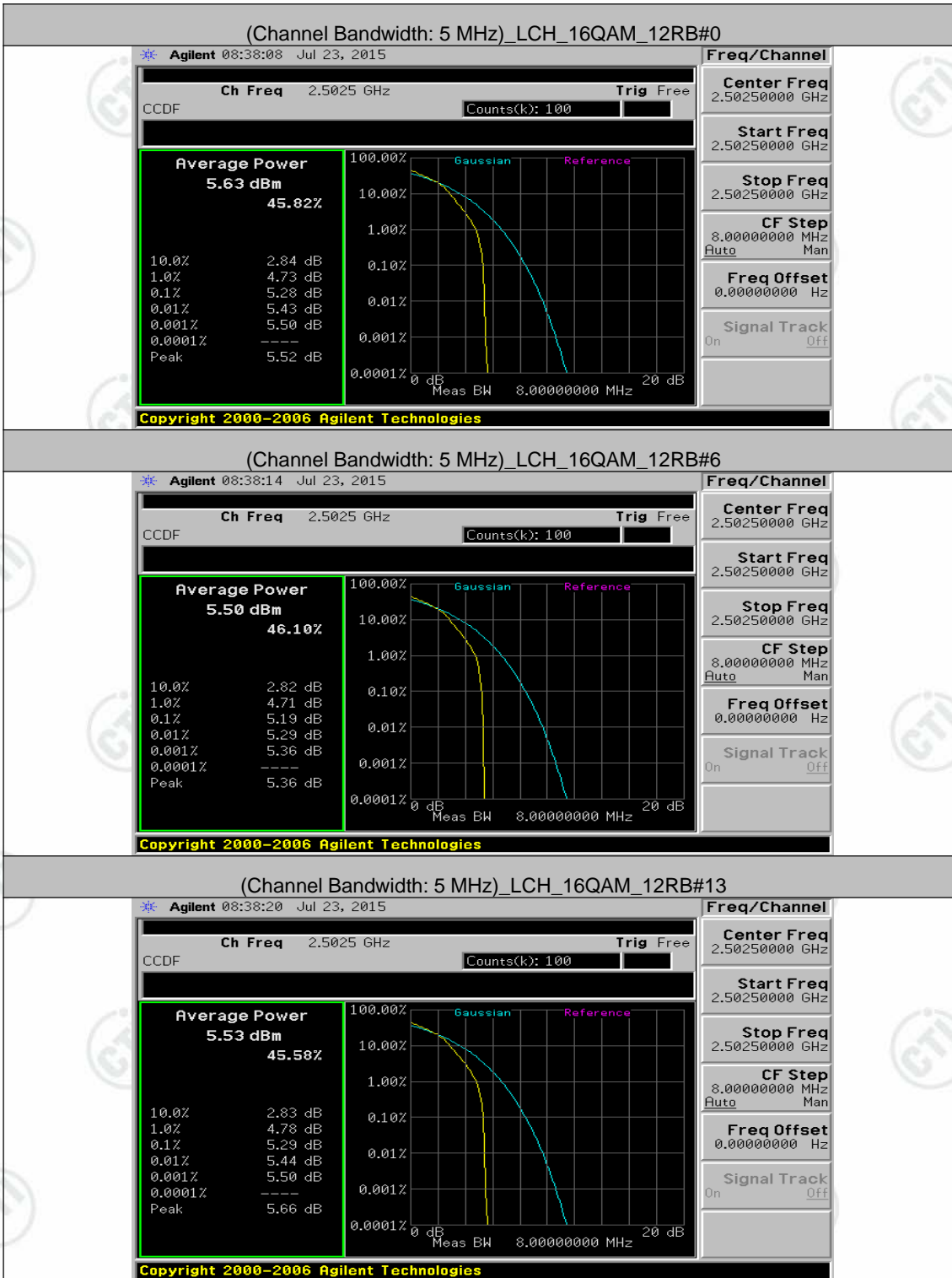

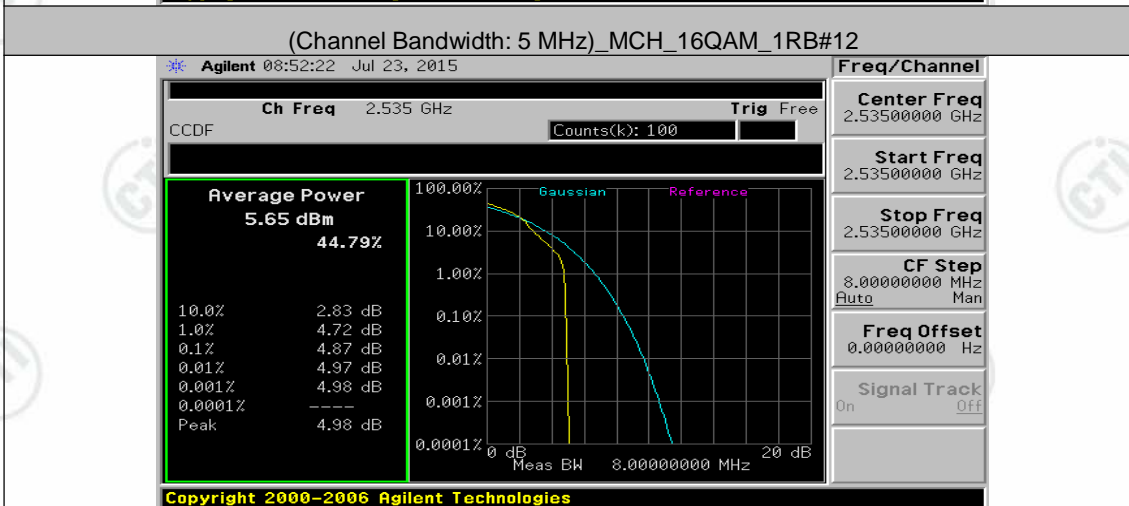
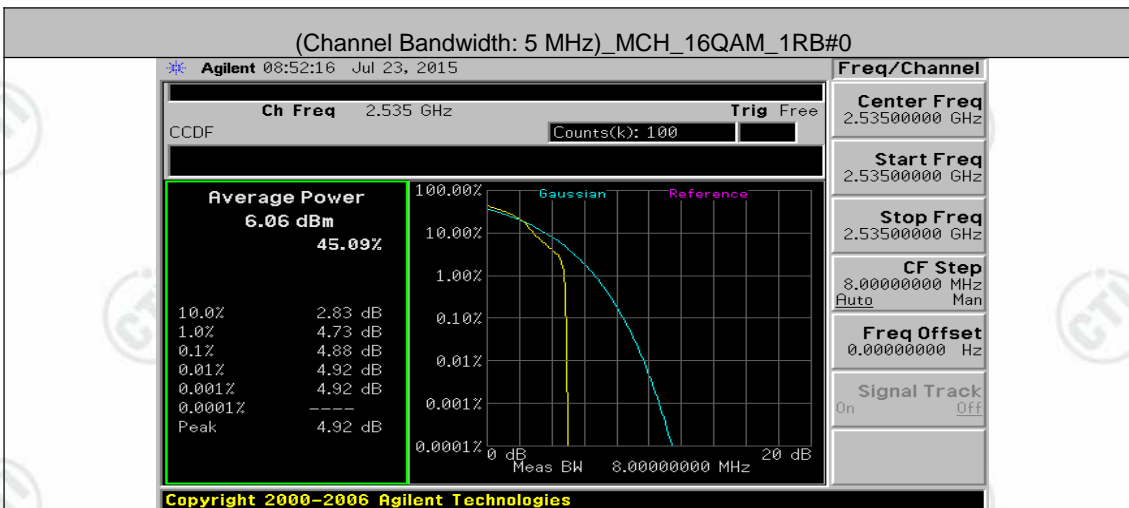
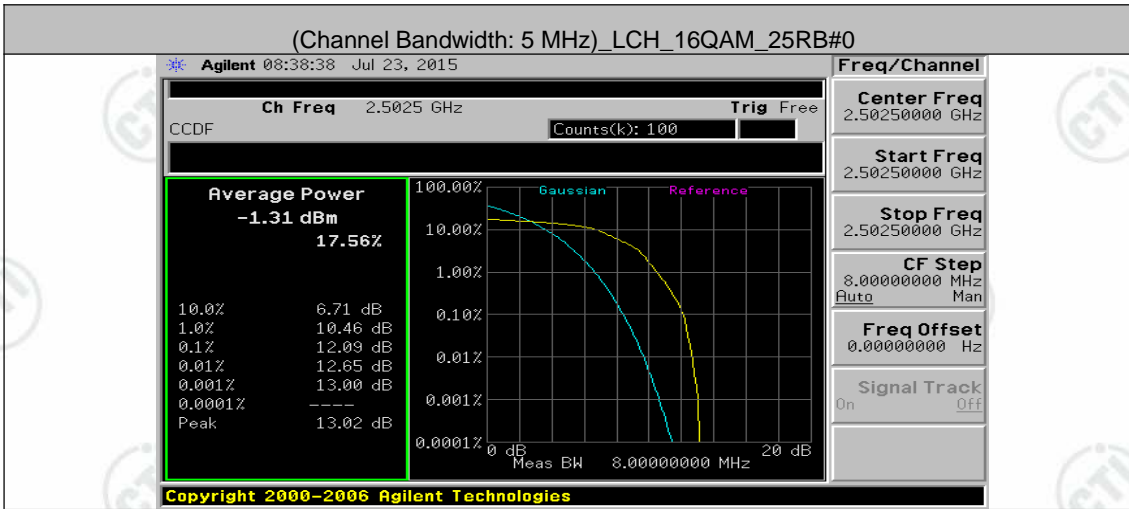

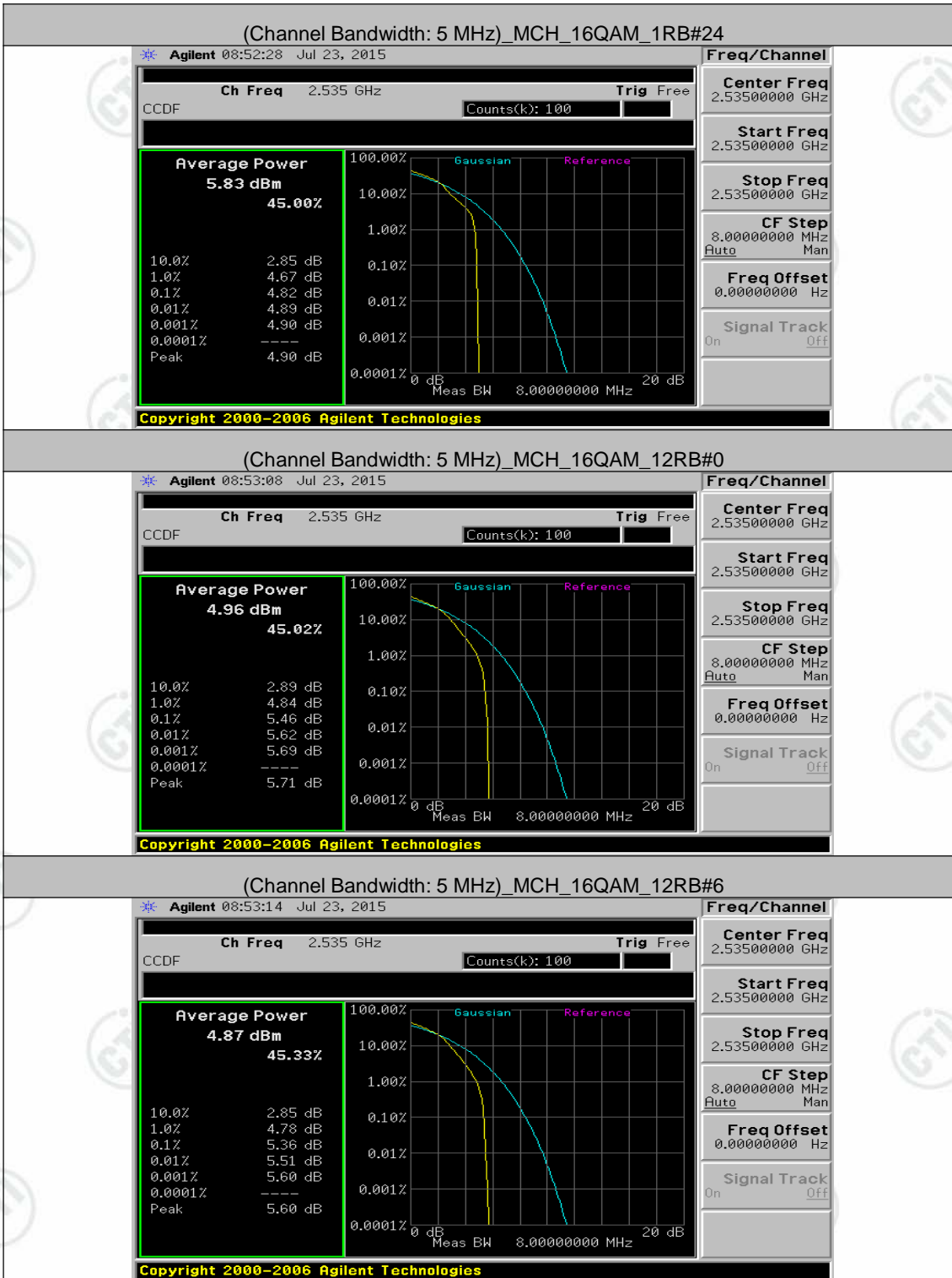

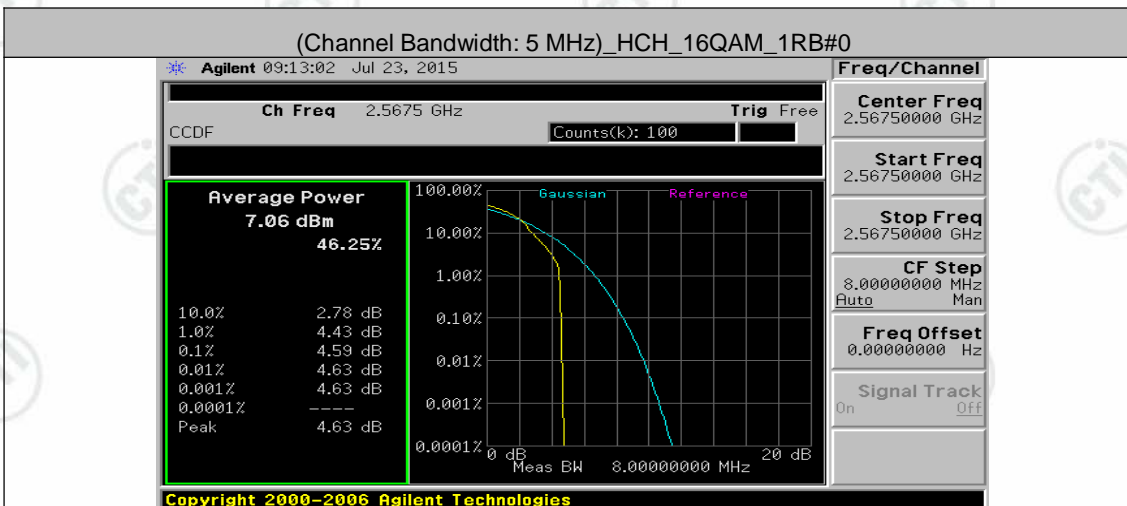
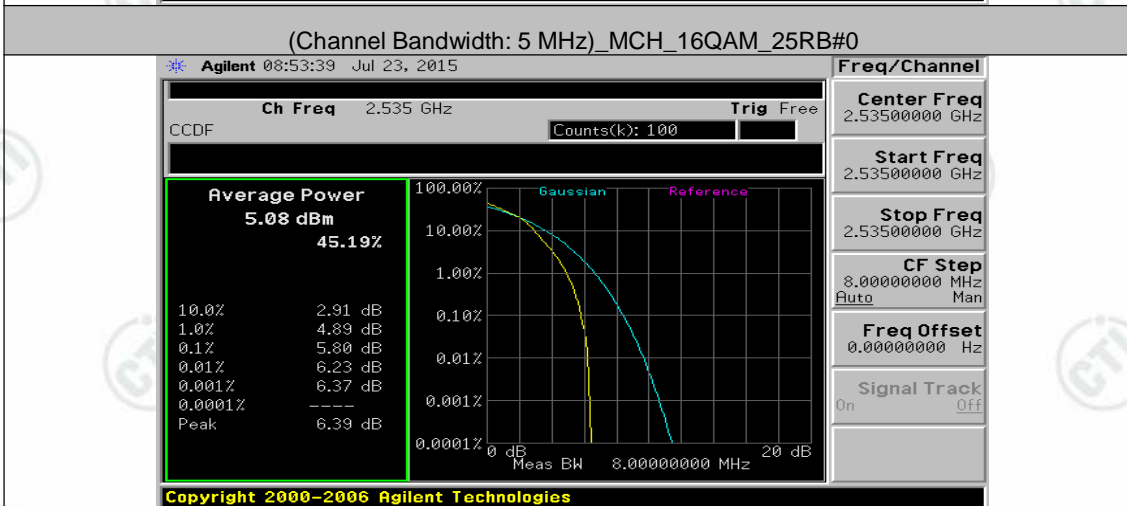
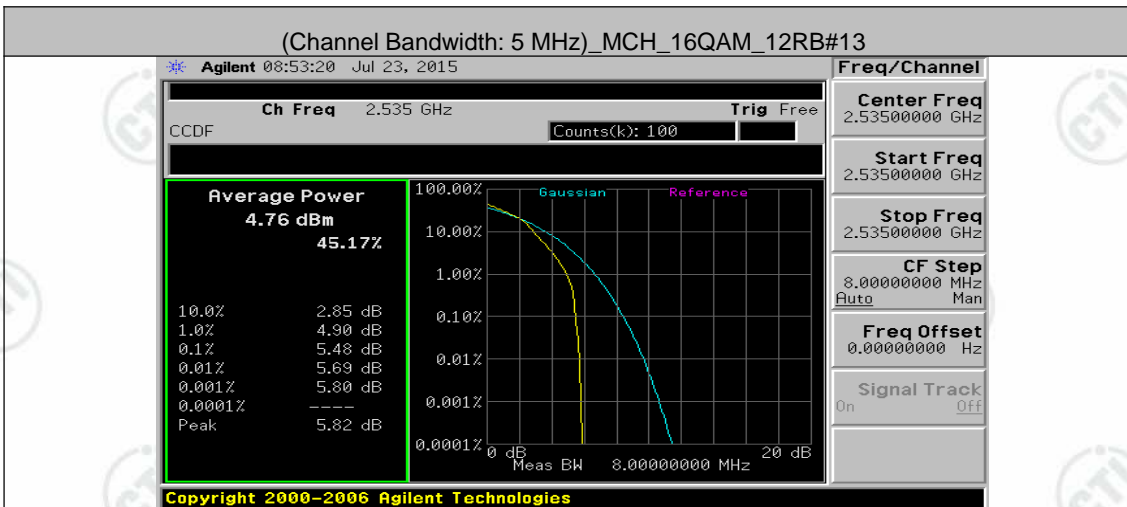





Channel Bandwidth: 10 MHz

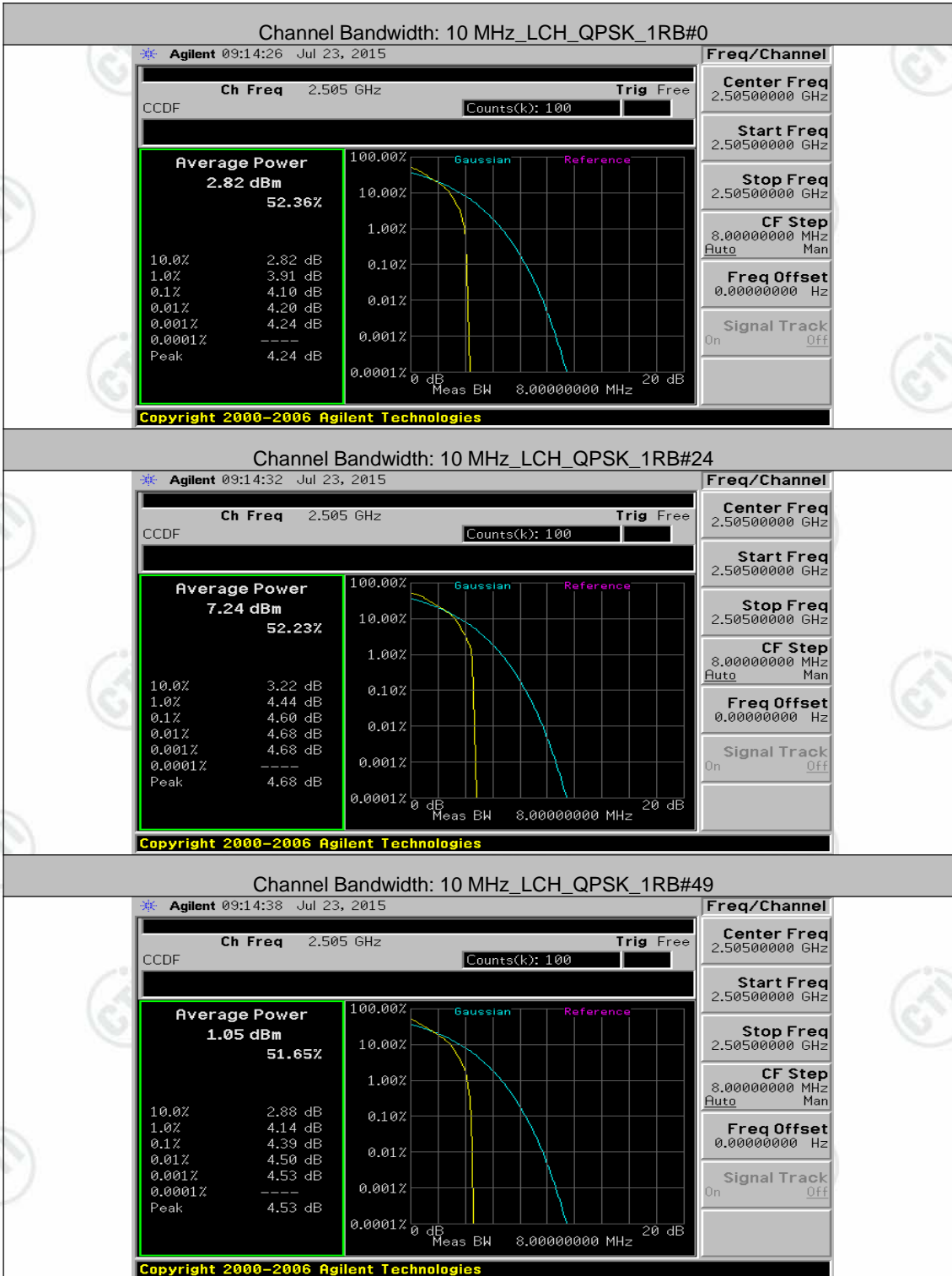

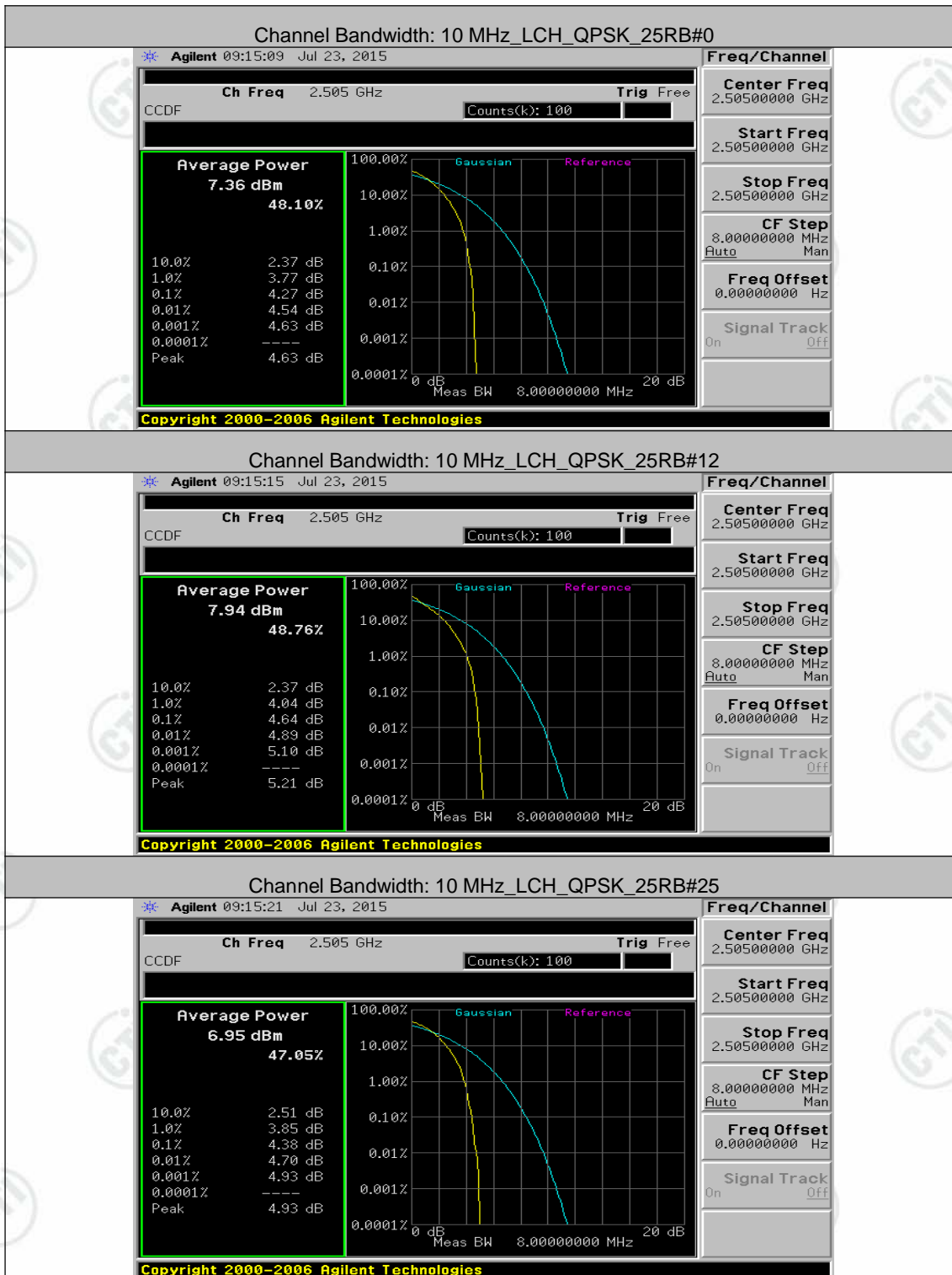

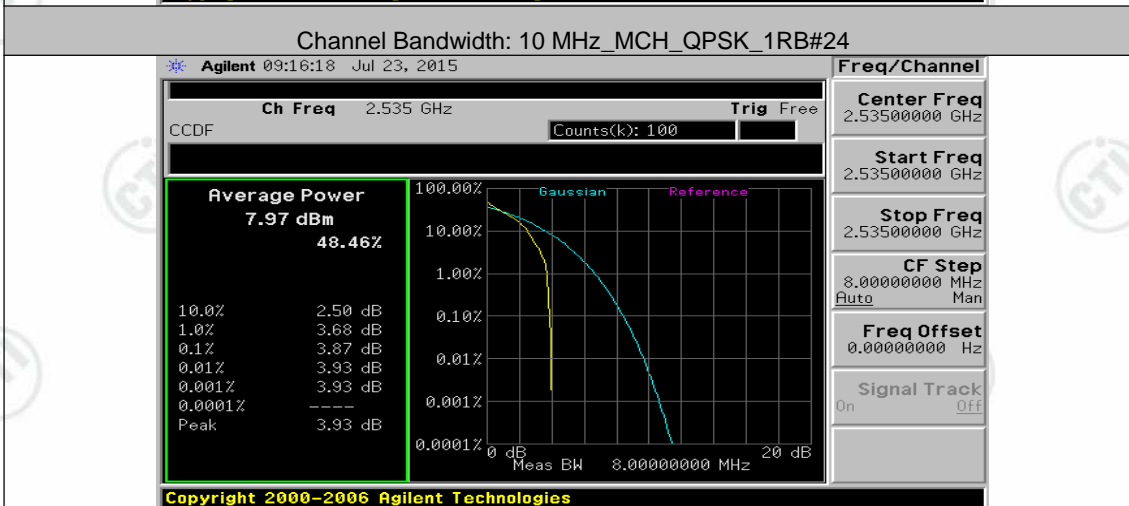
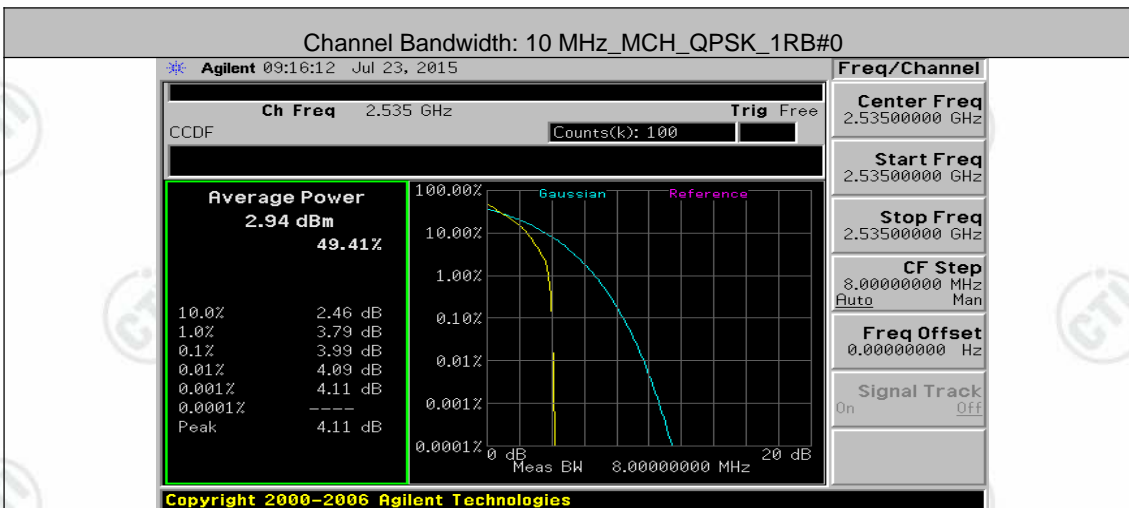
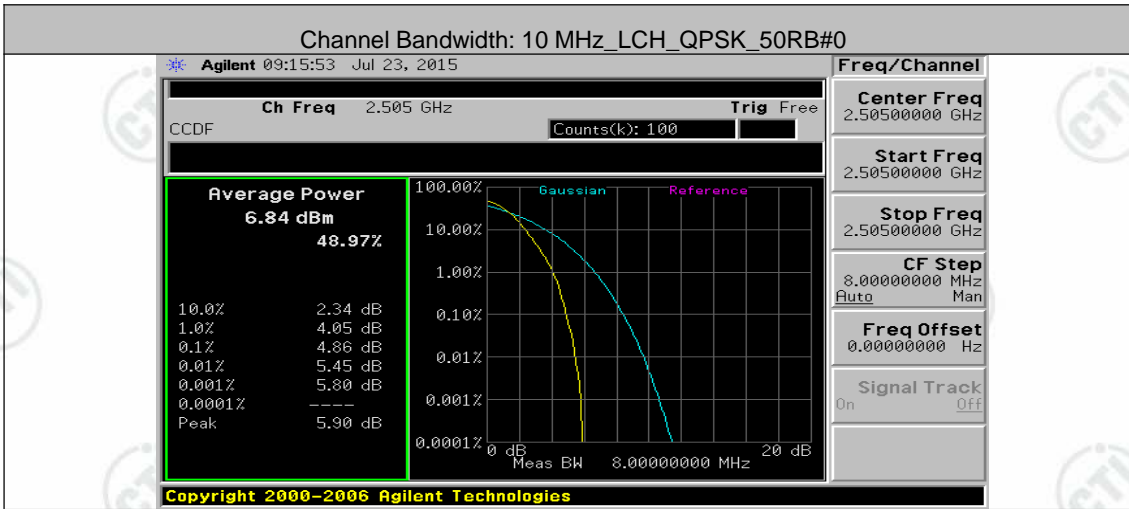

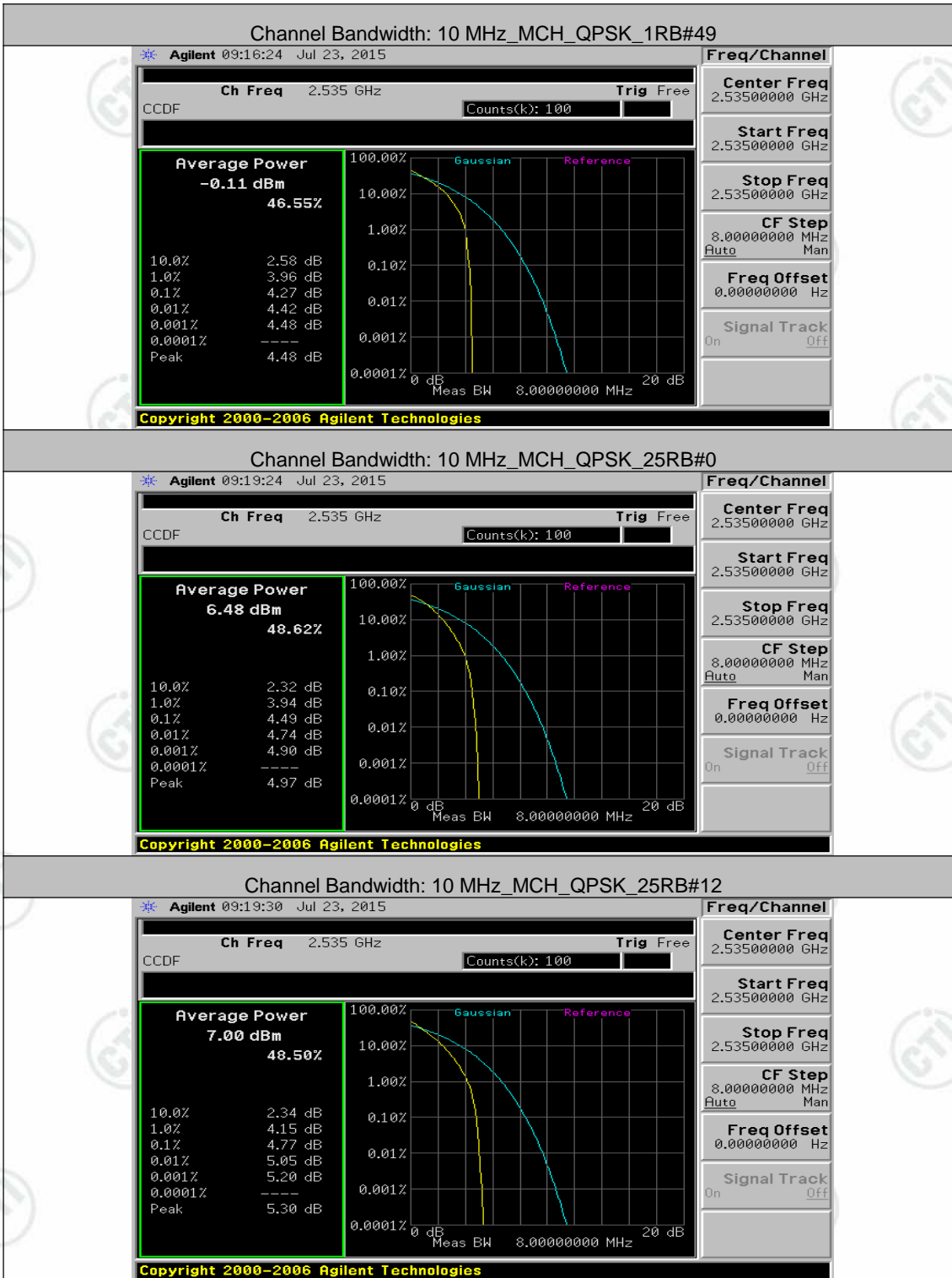

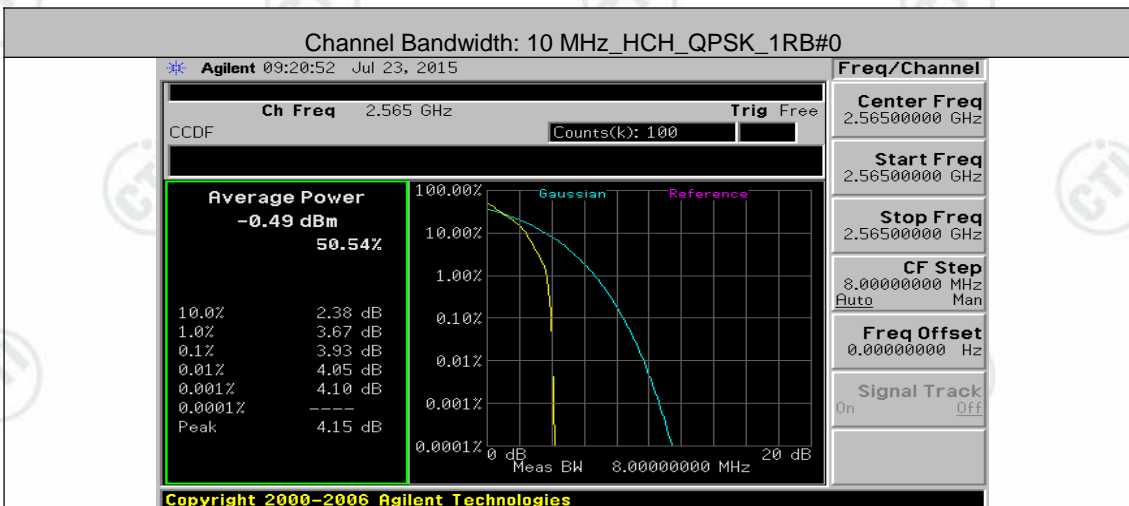
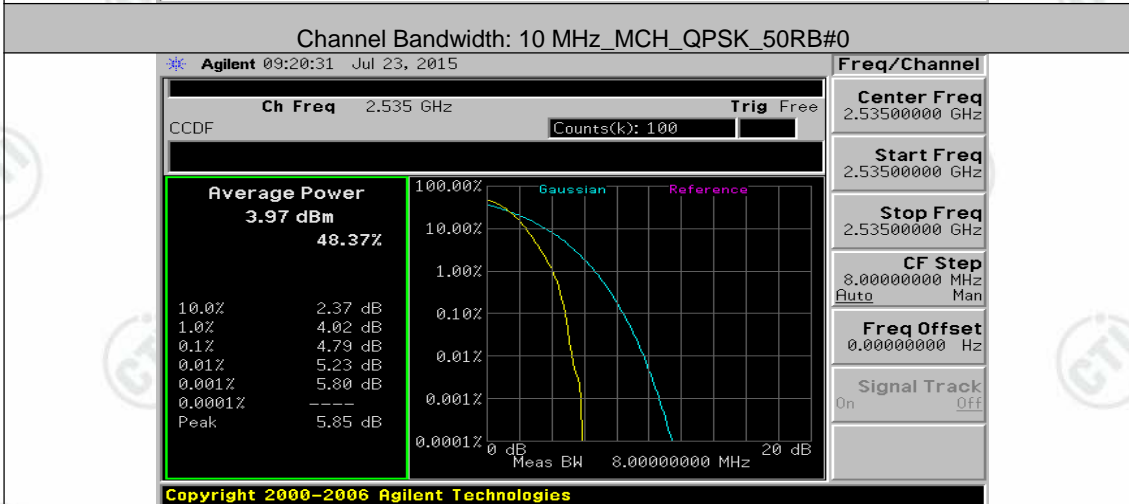
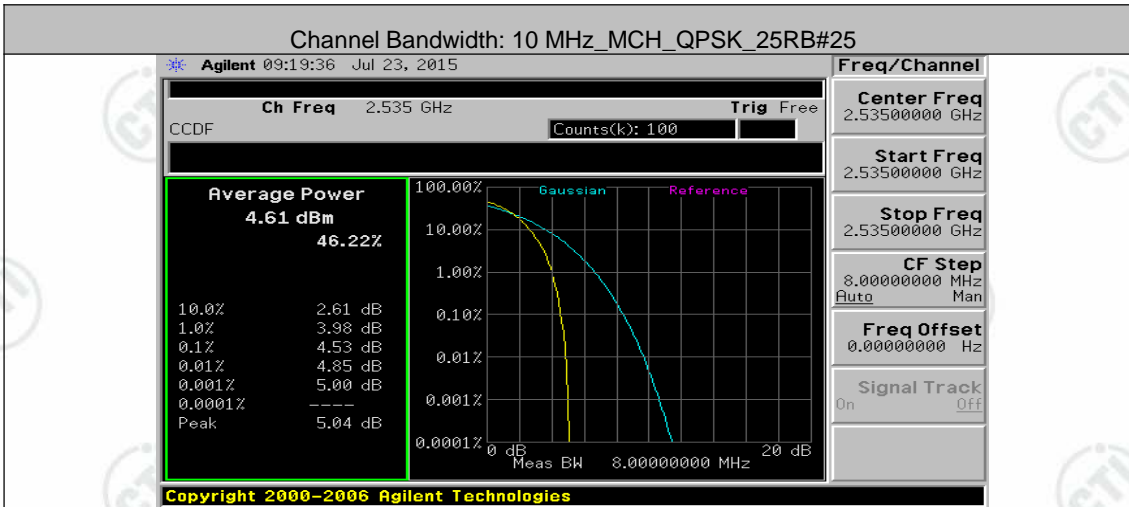



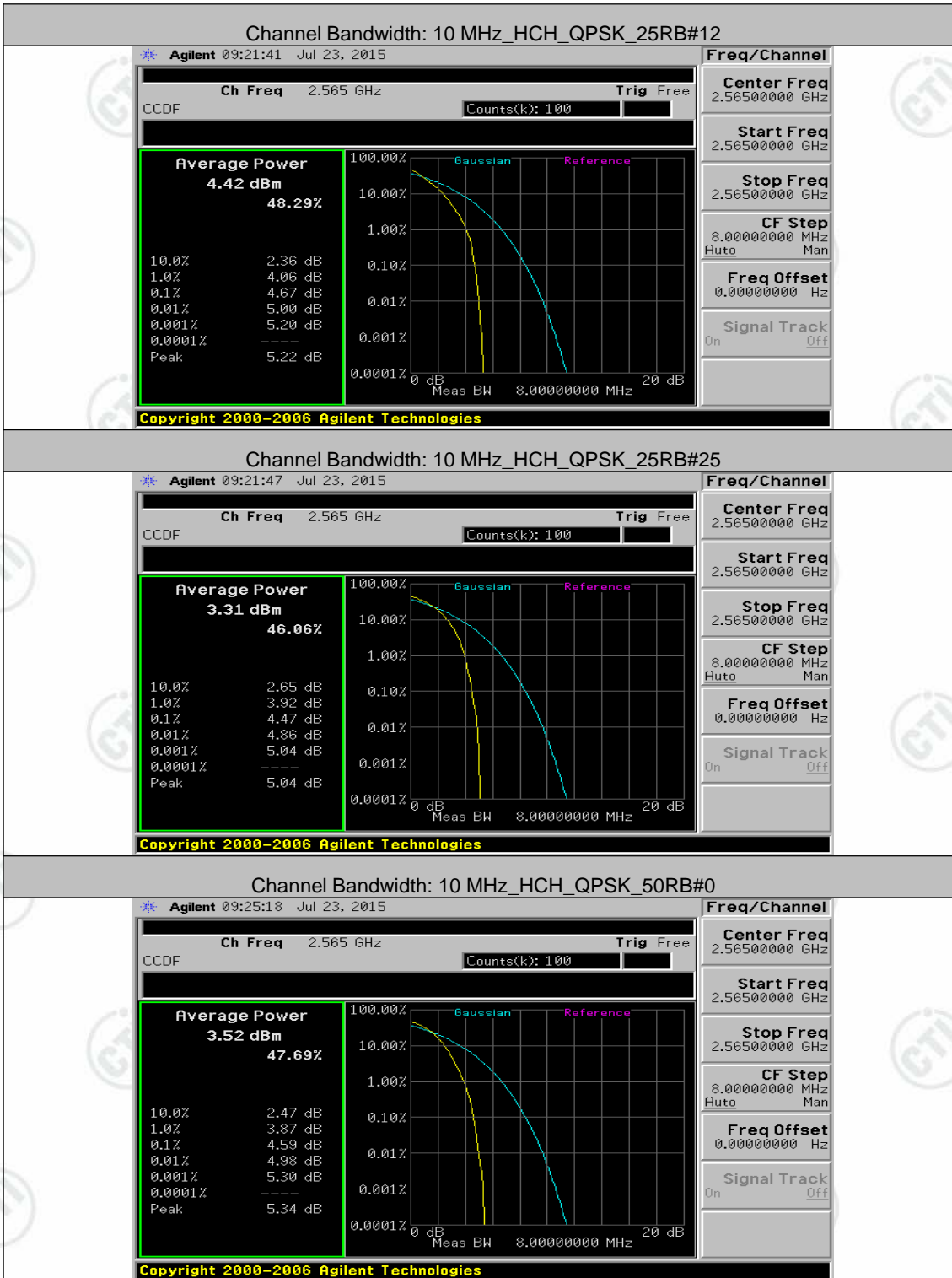

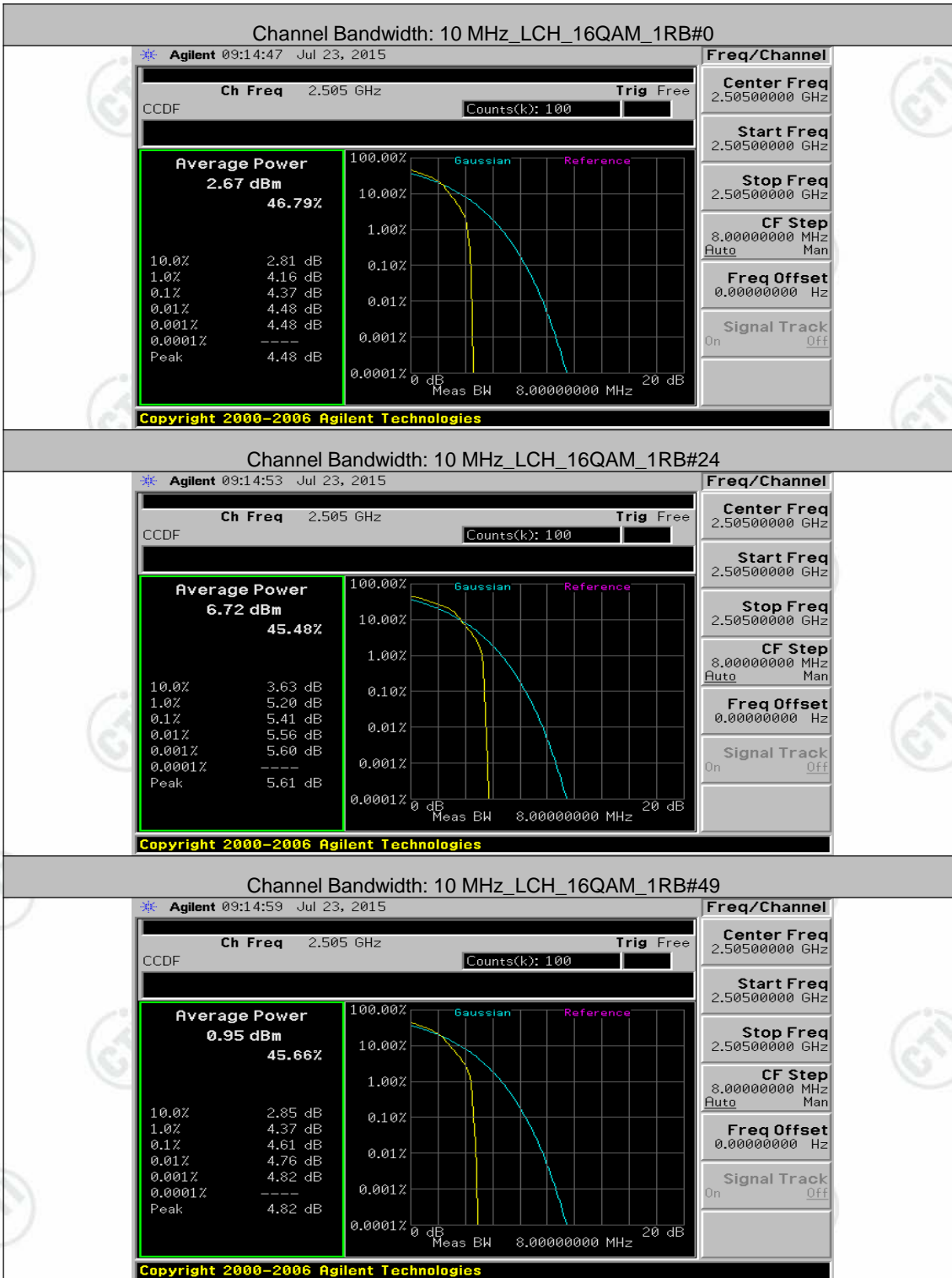



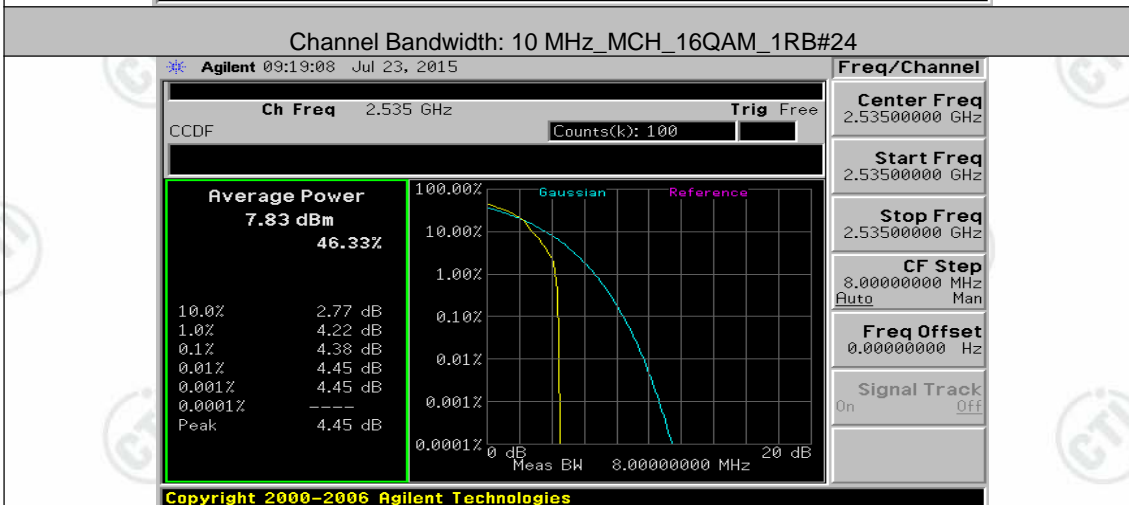
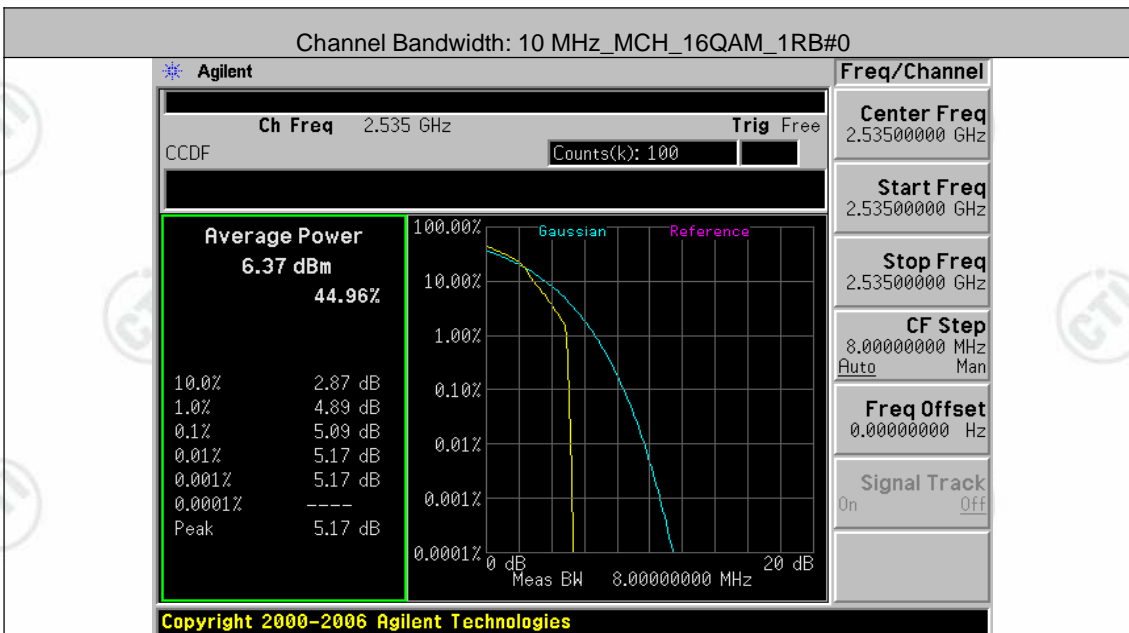
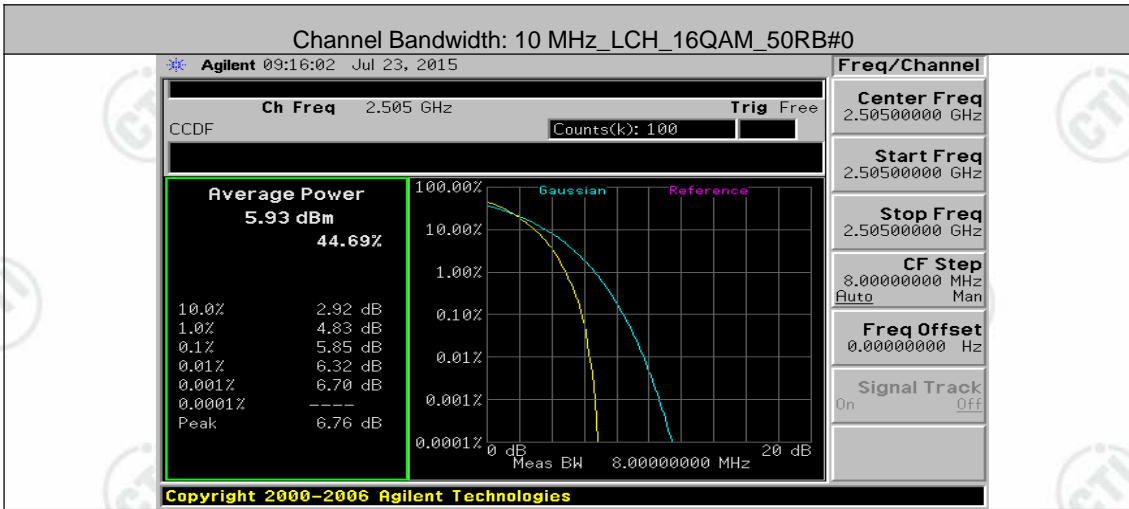



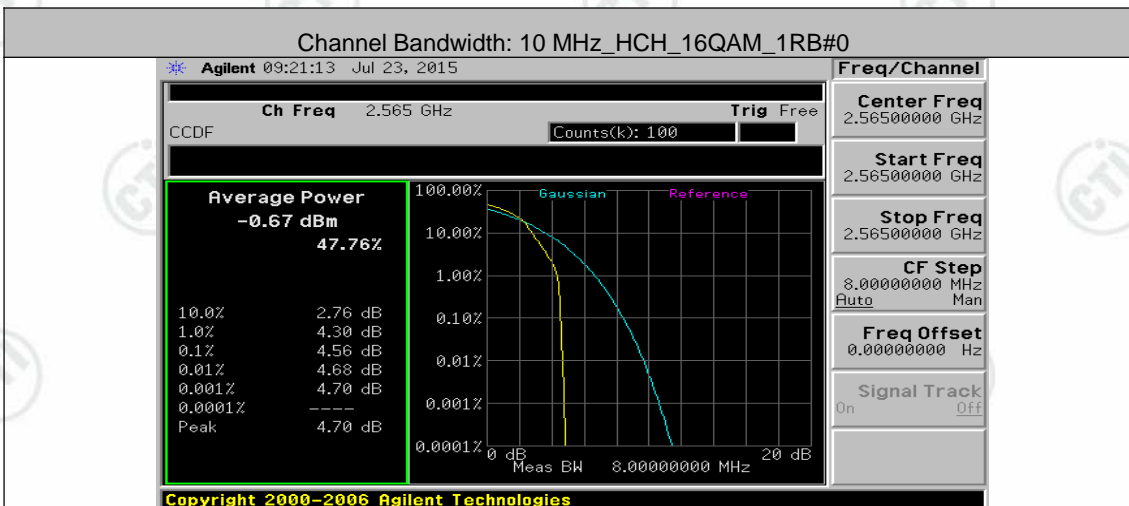
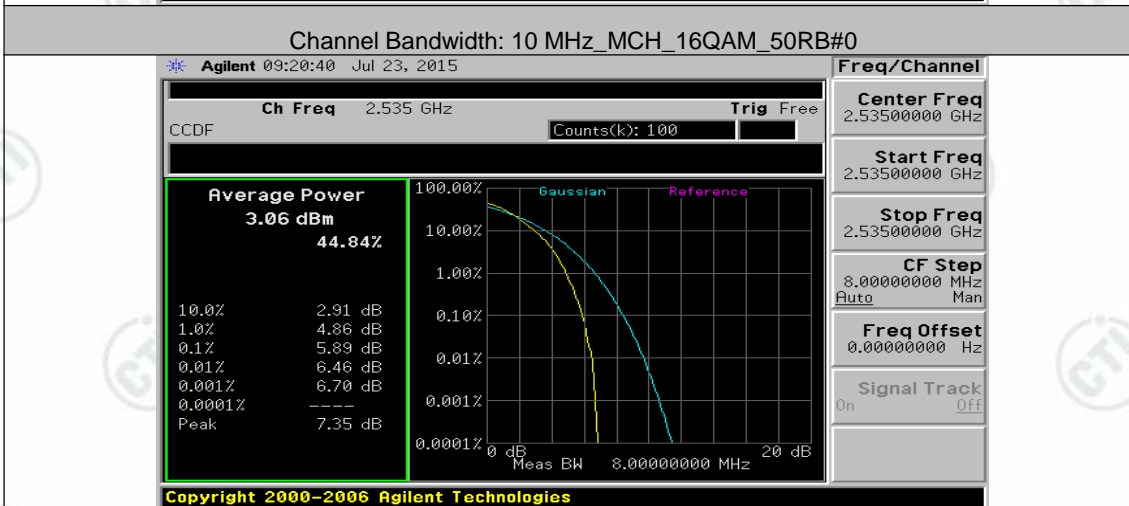
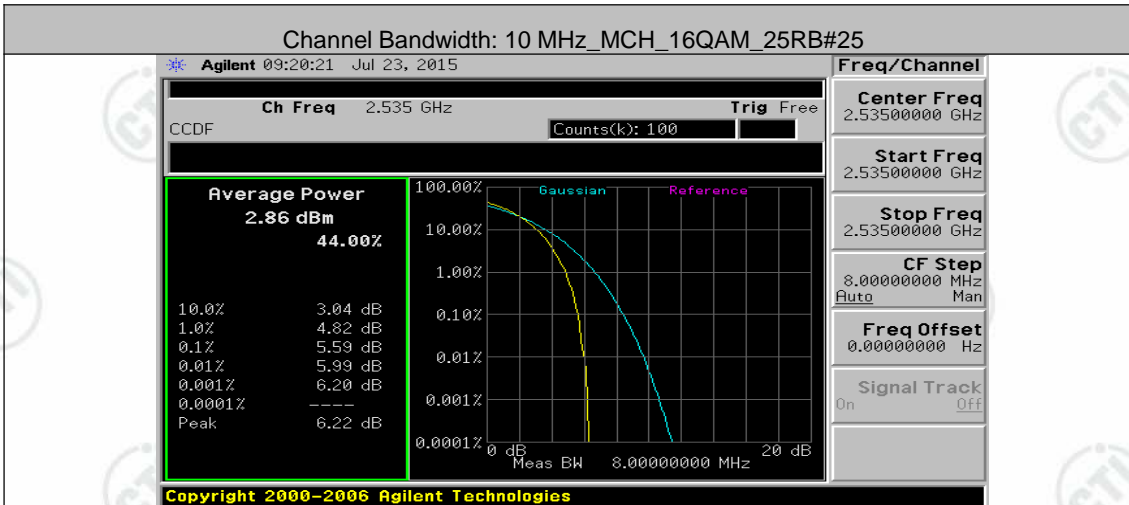

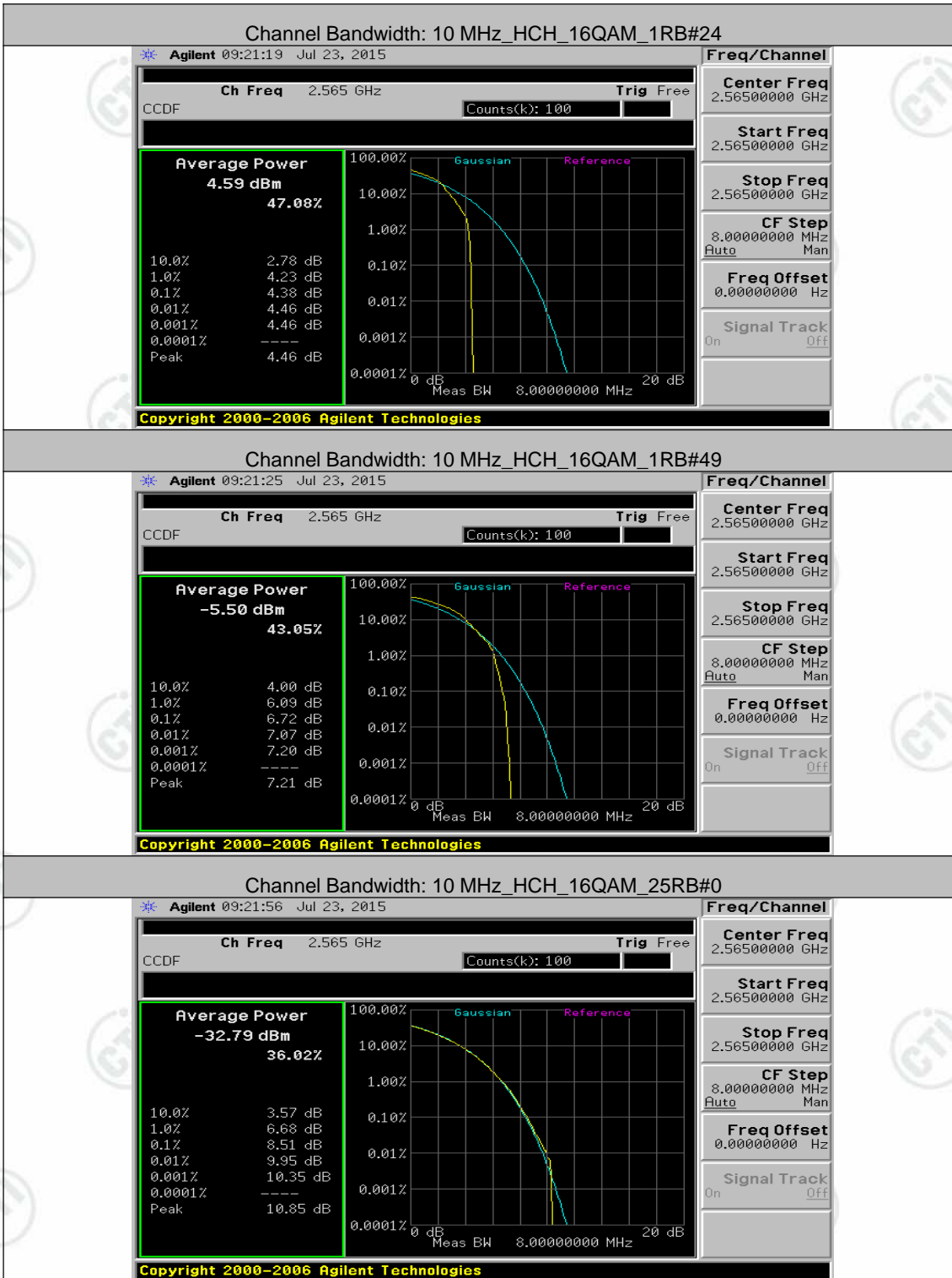

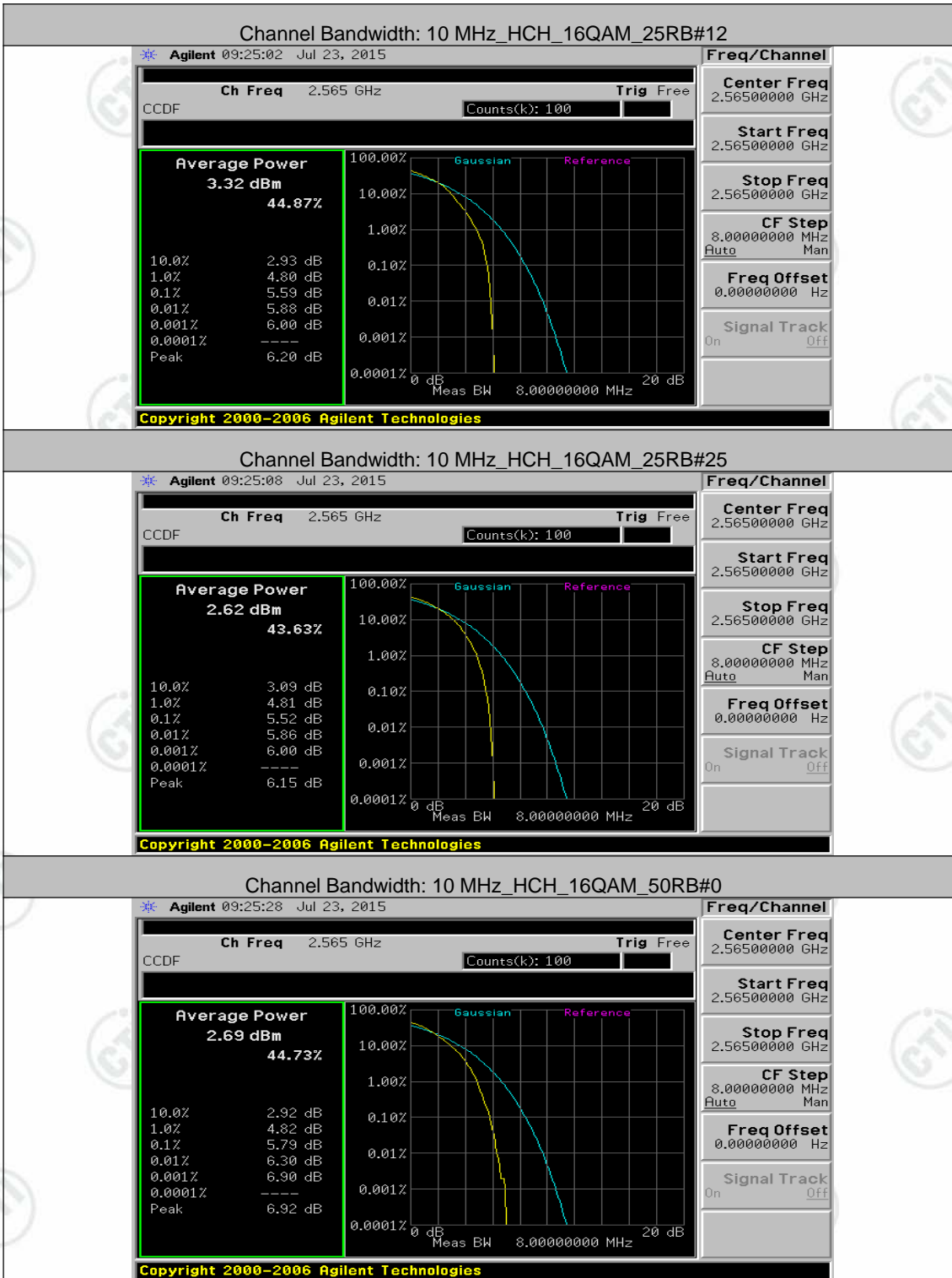

Channel Bandwidth: 15 MHz



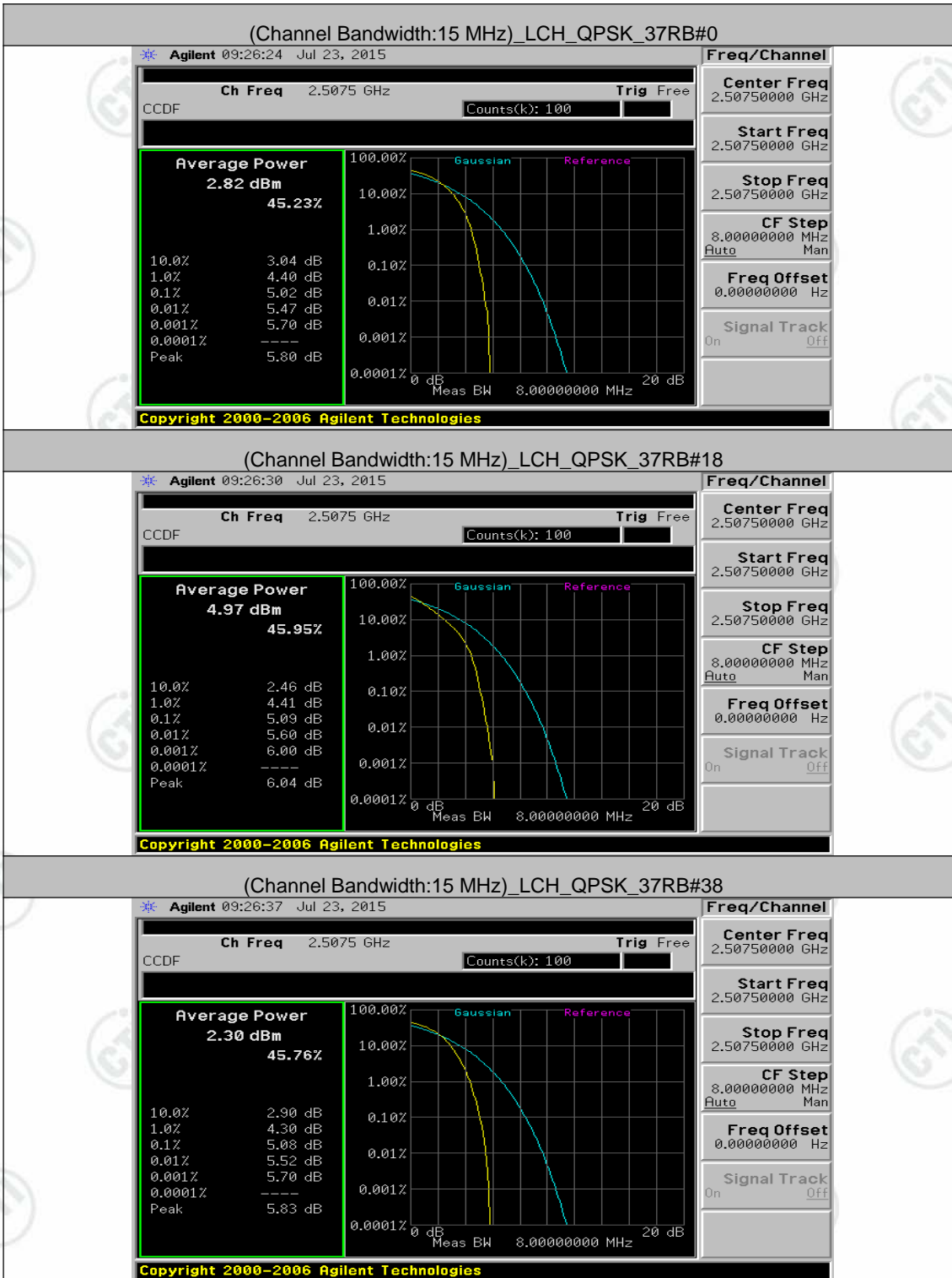

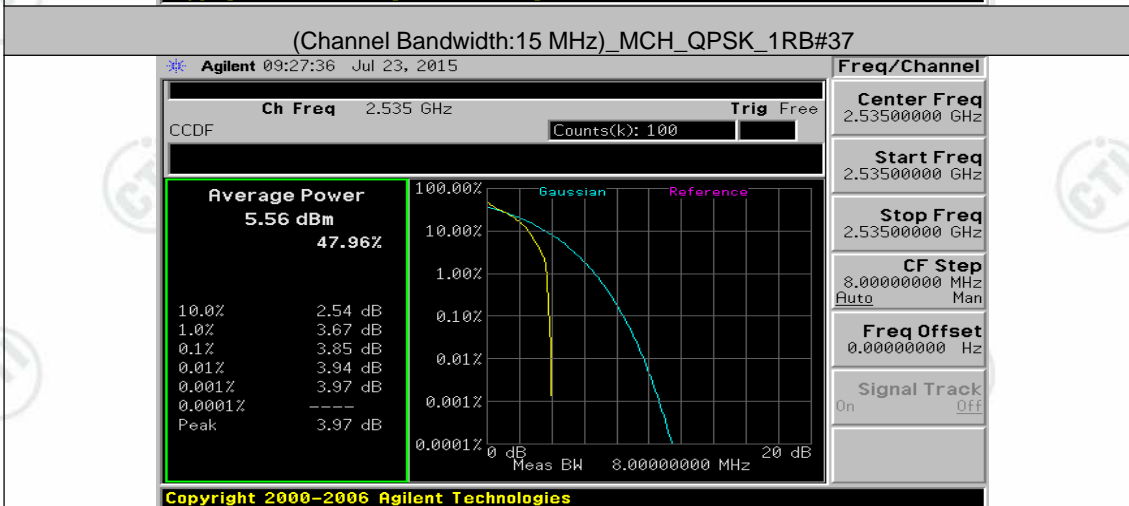
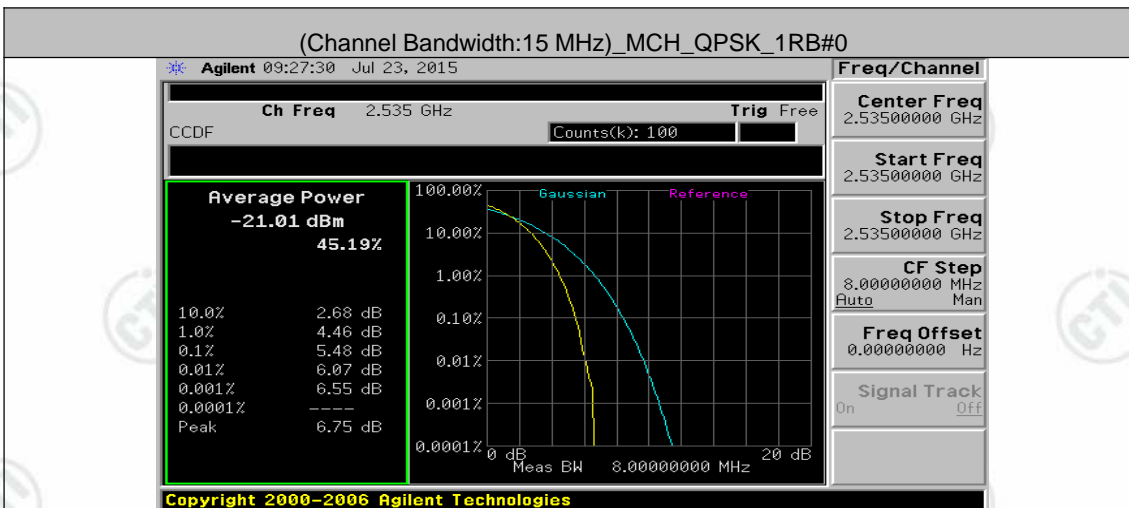
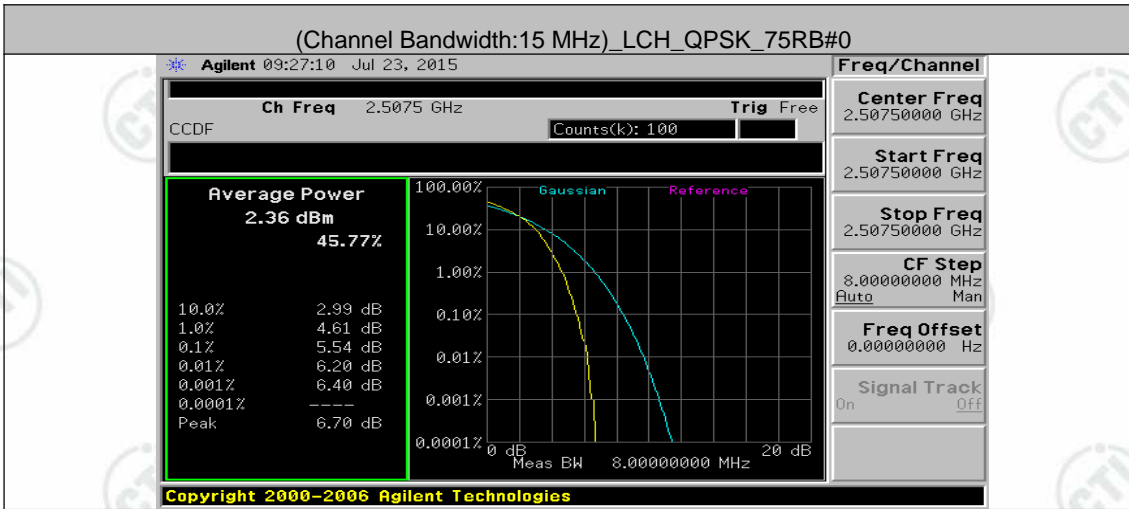



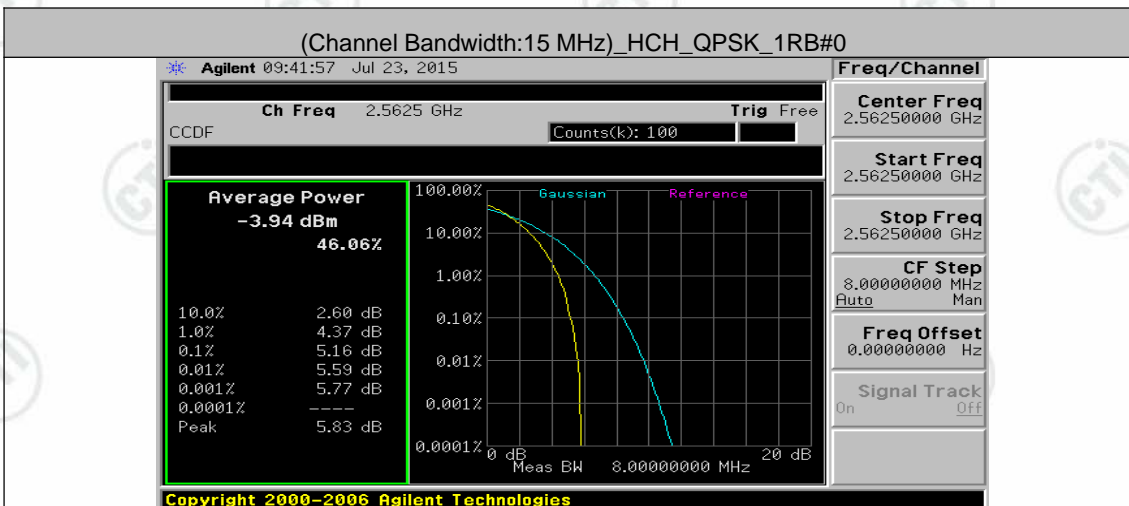
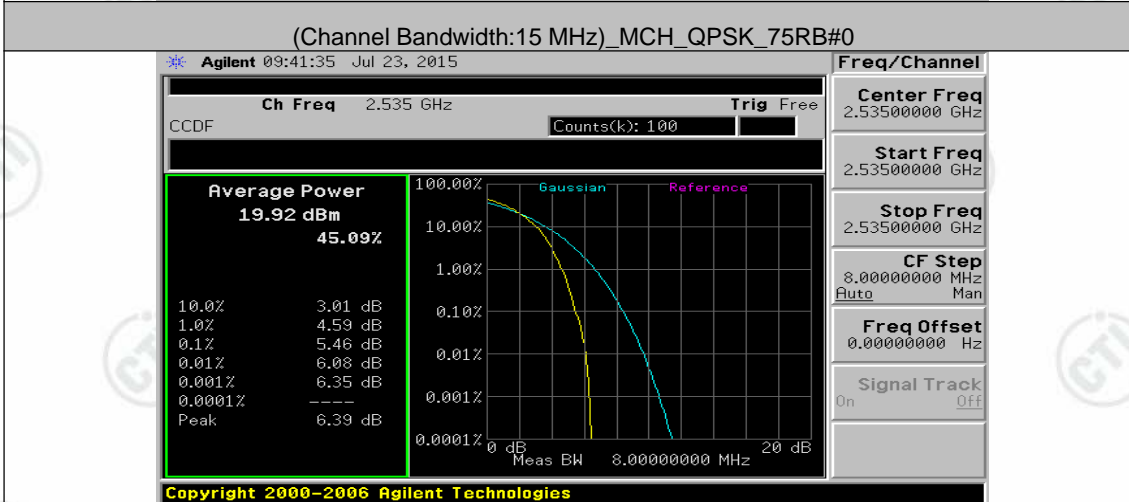
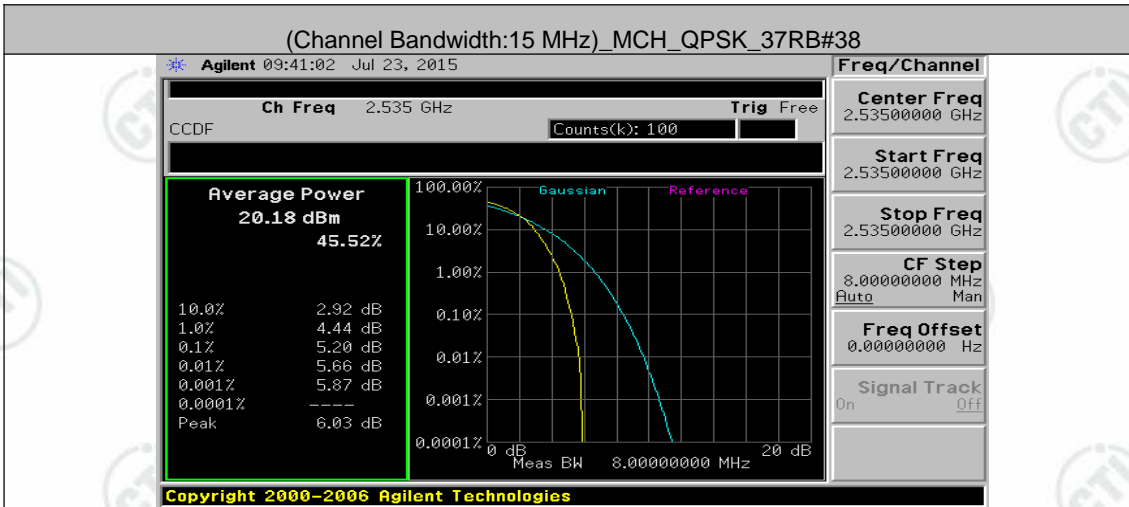

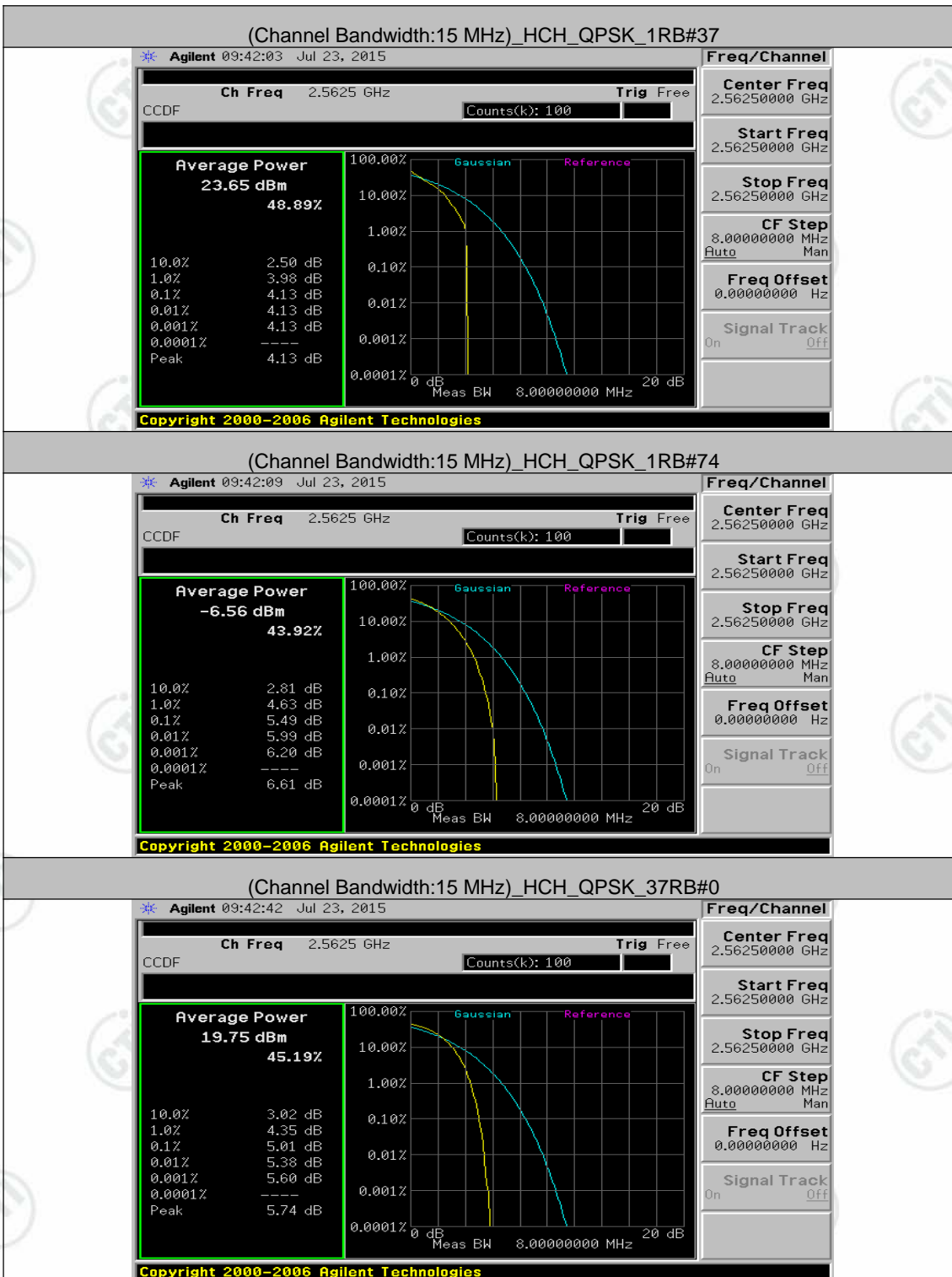

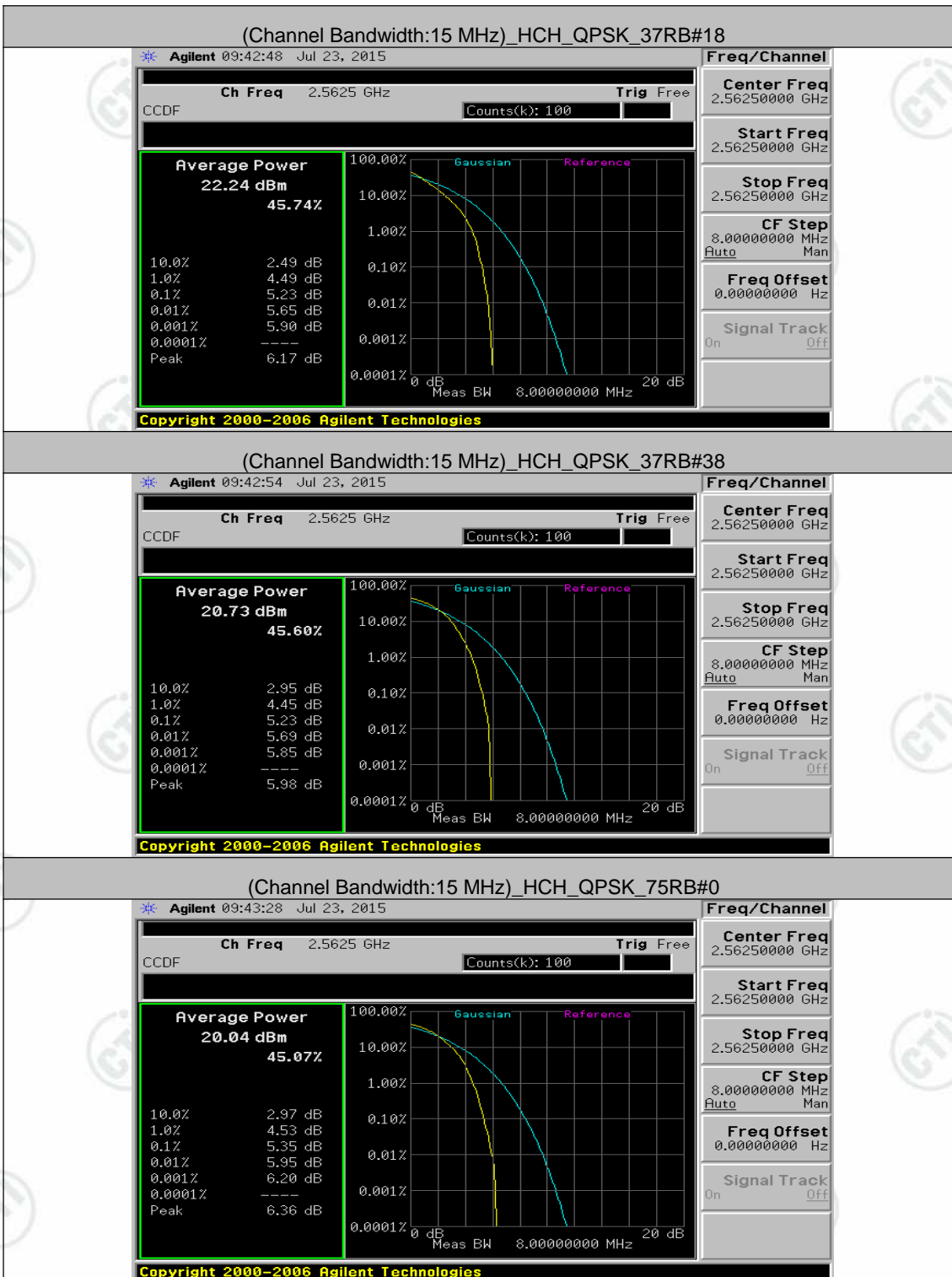

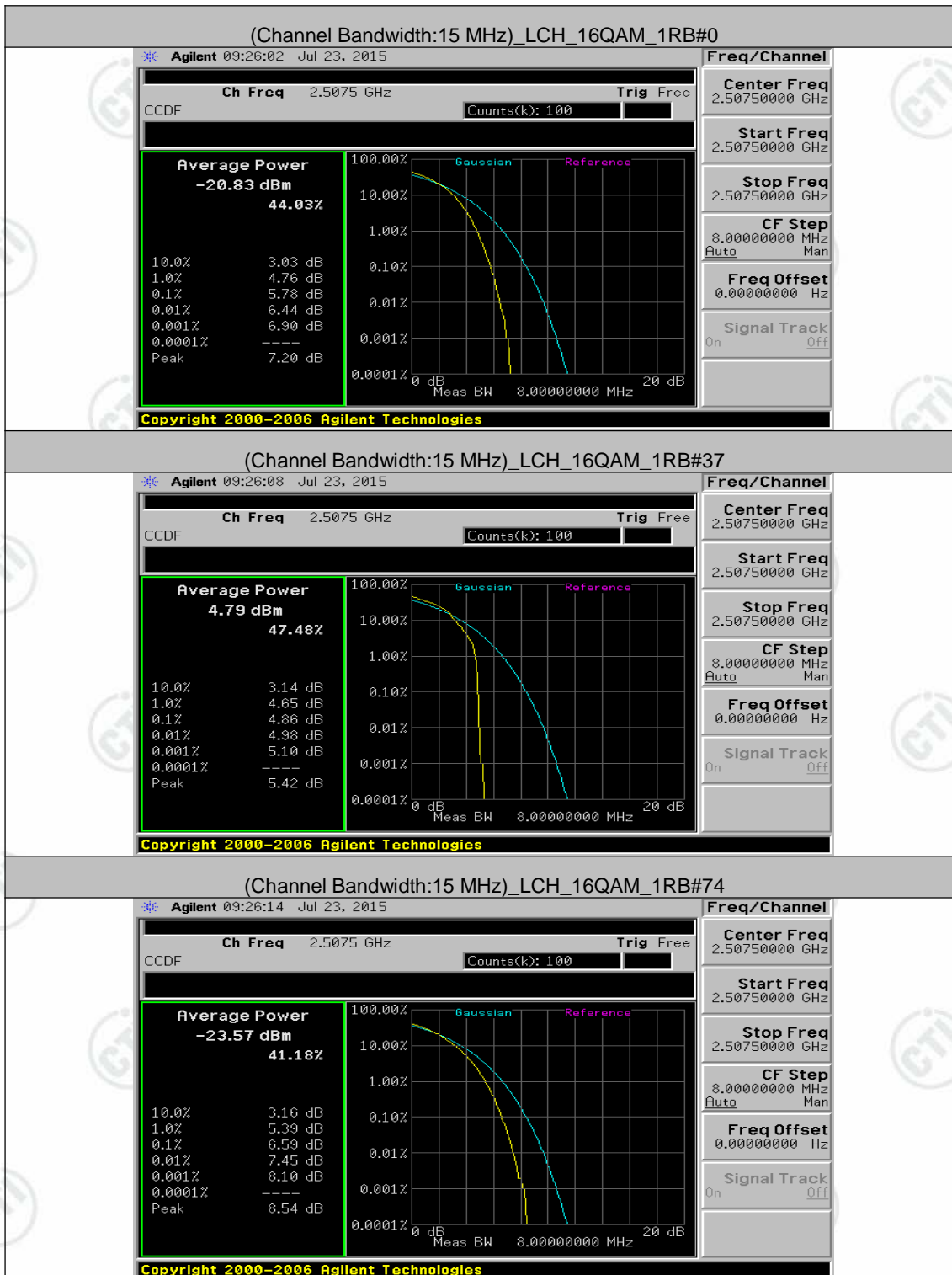



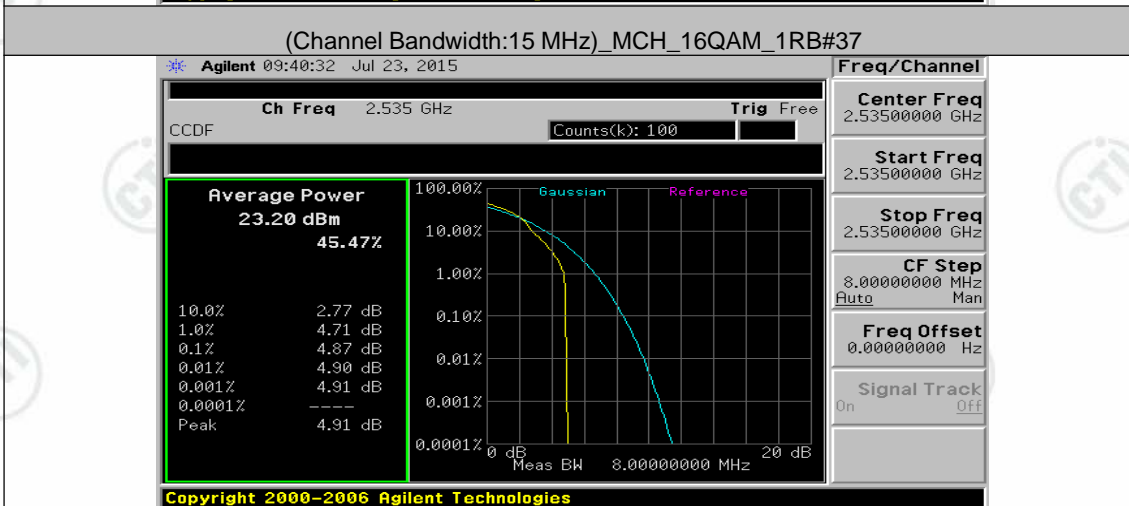
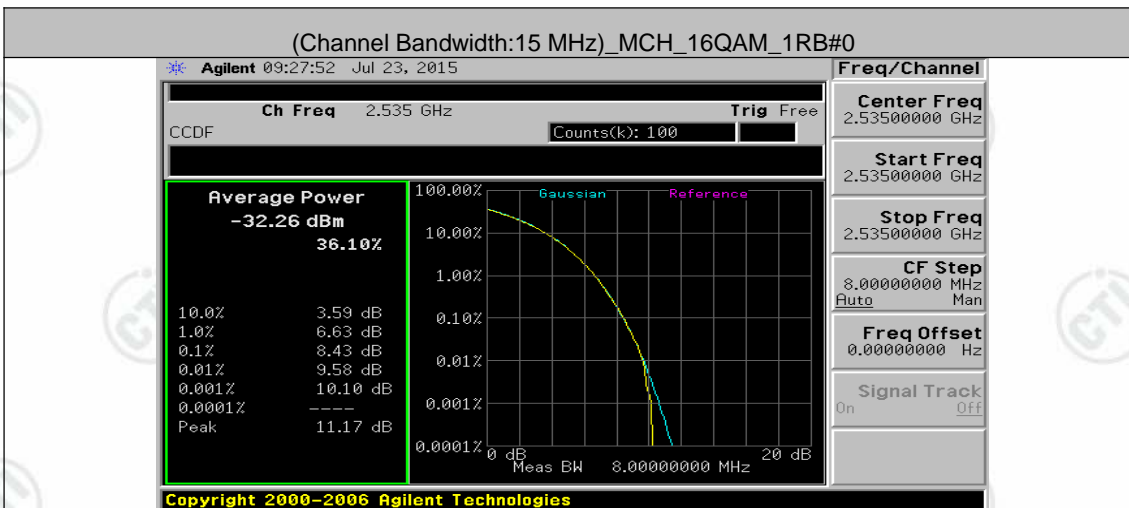
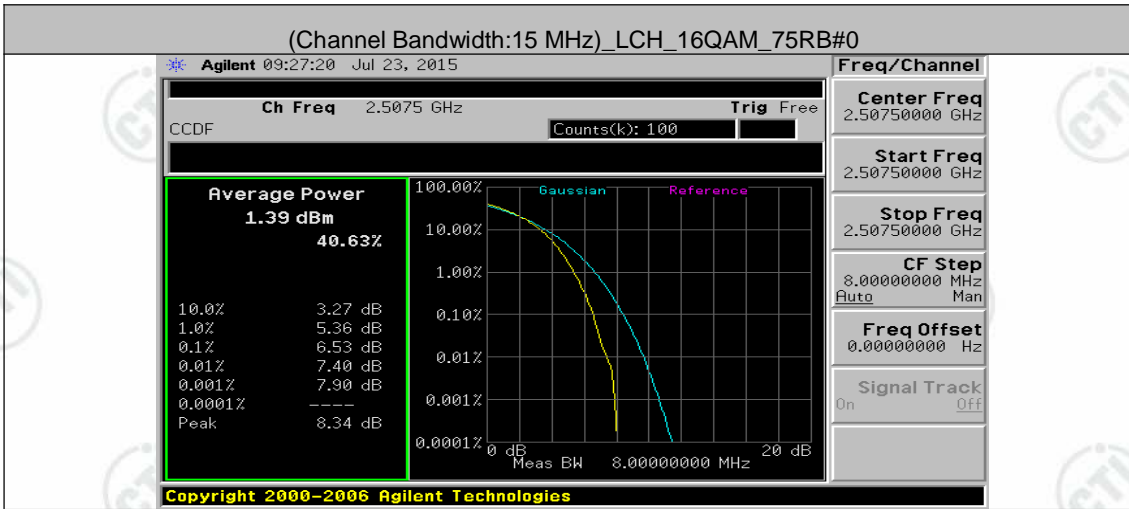



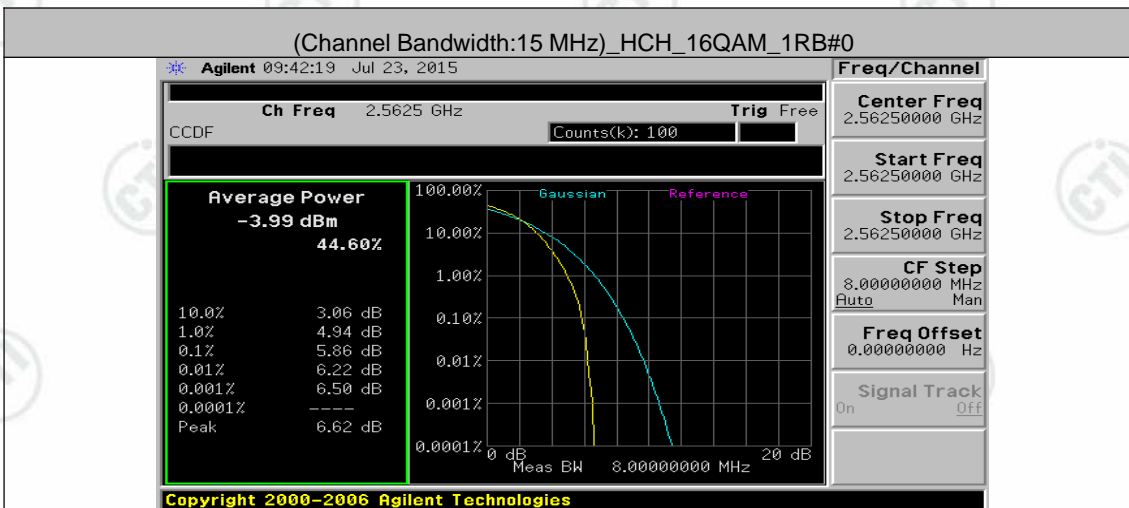
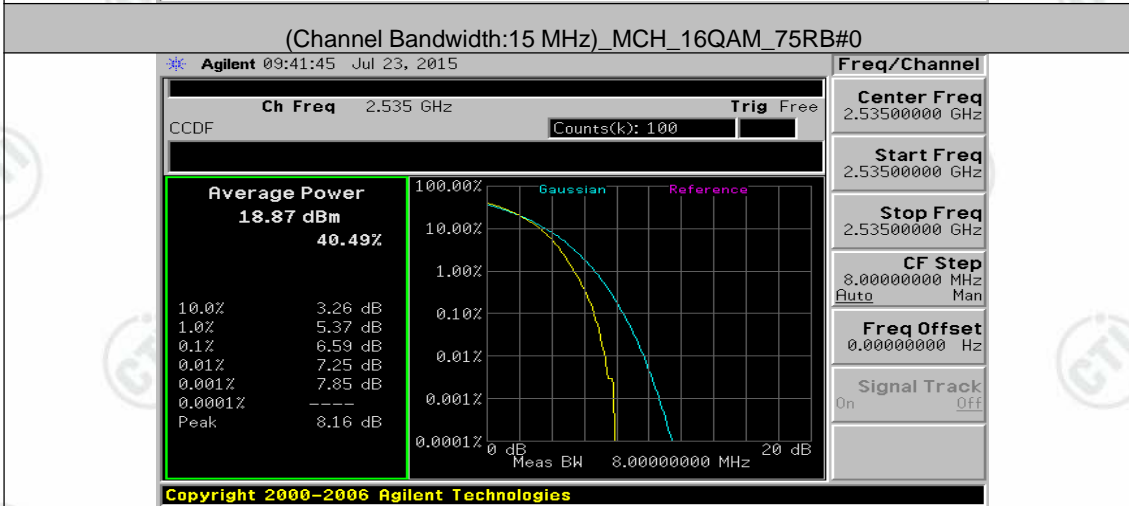
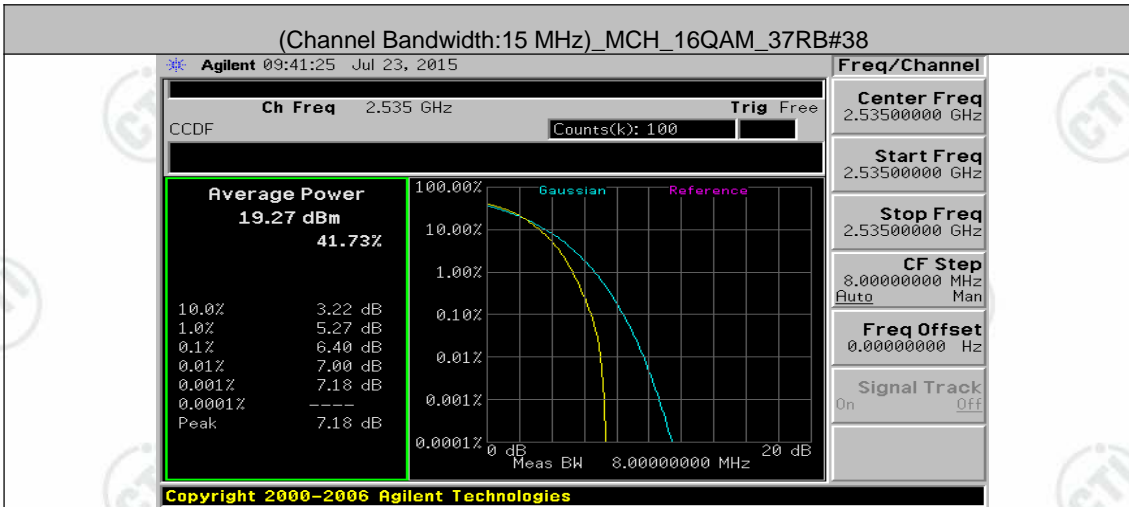

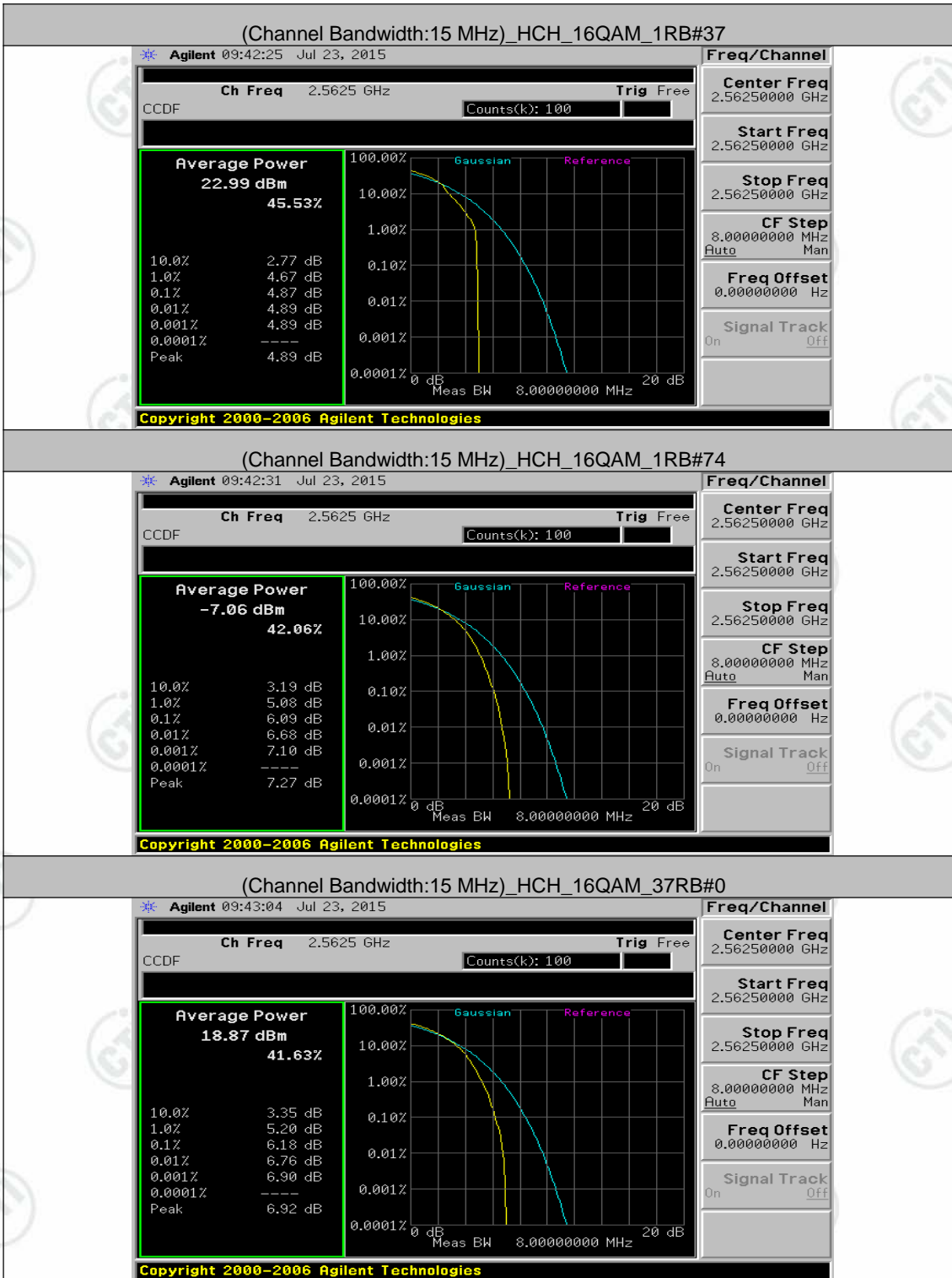

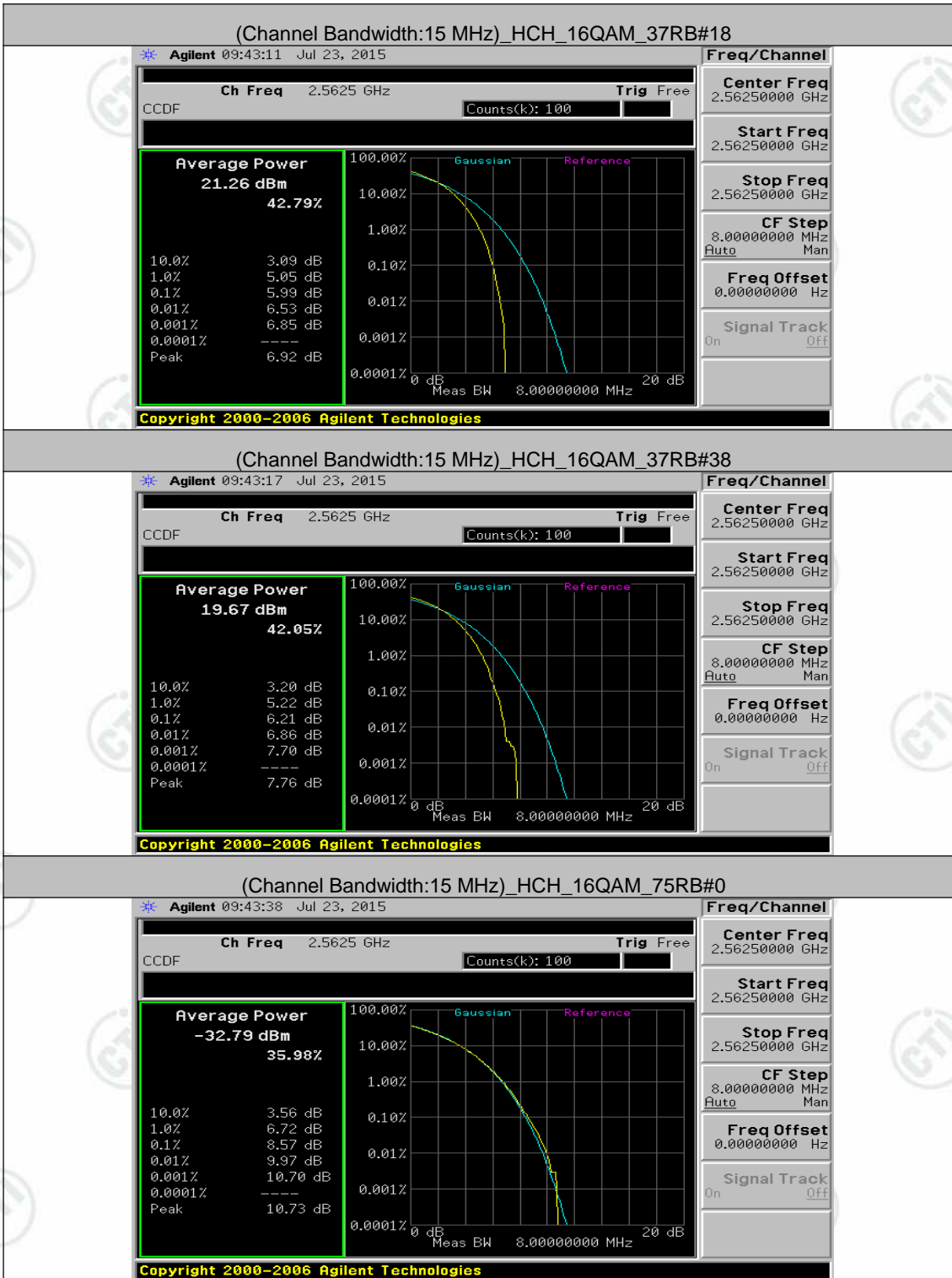

Channel Bandwidth: 20 MHz





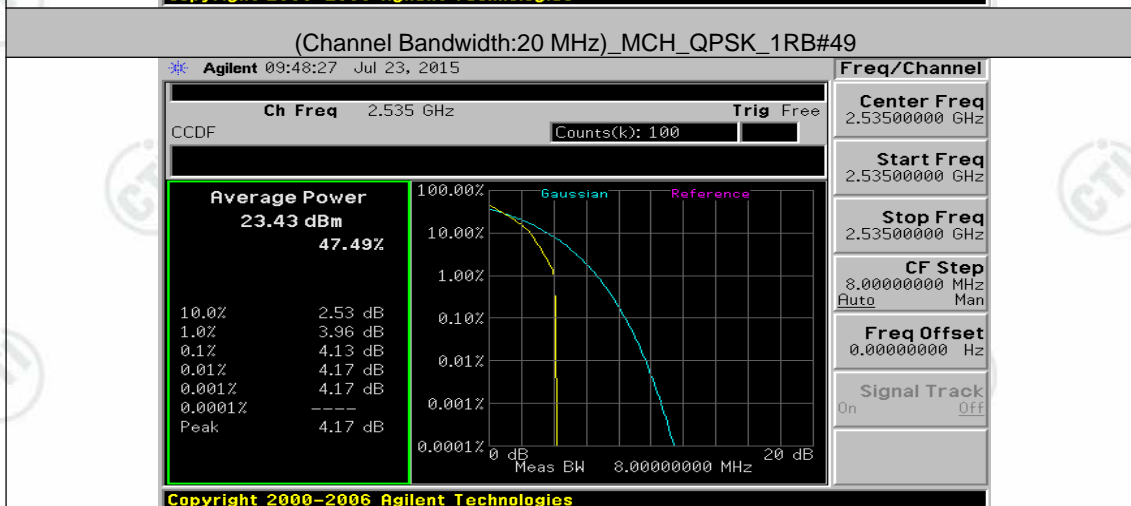
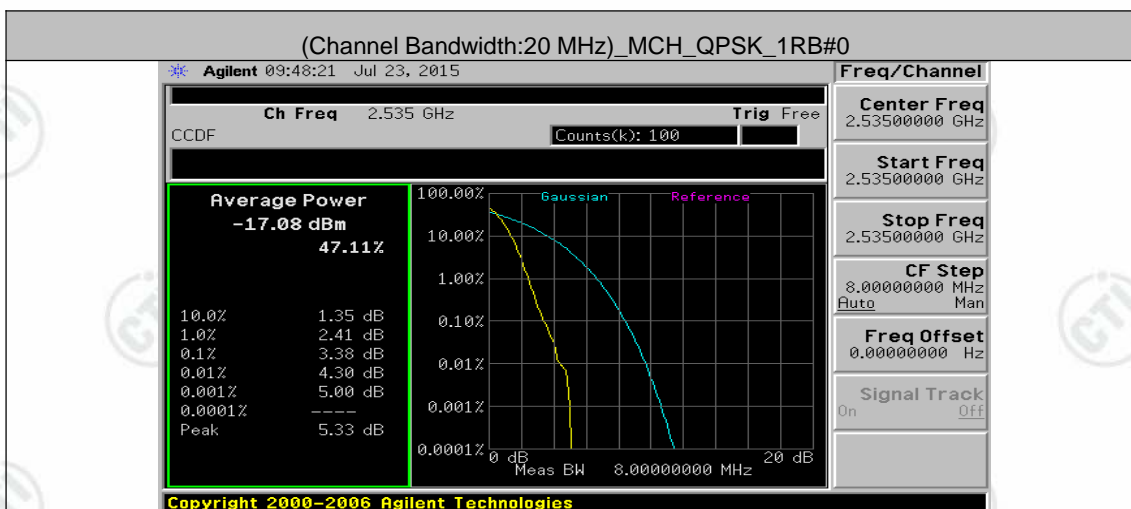
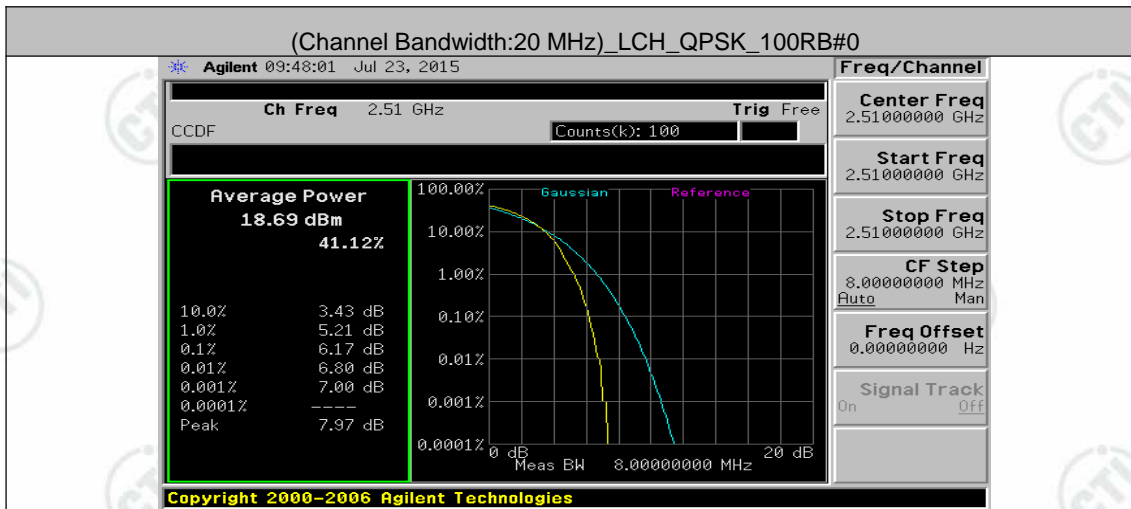

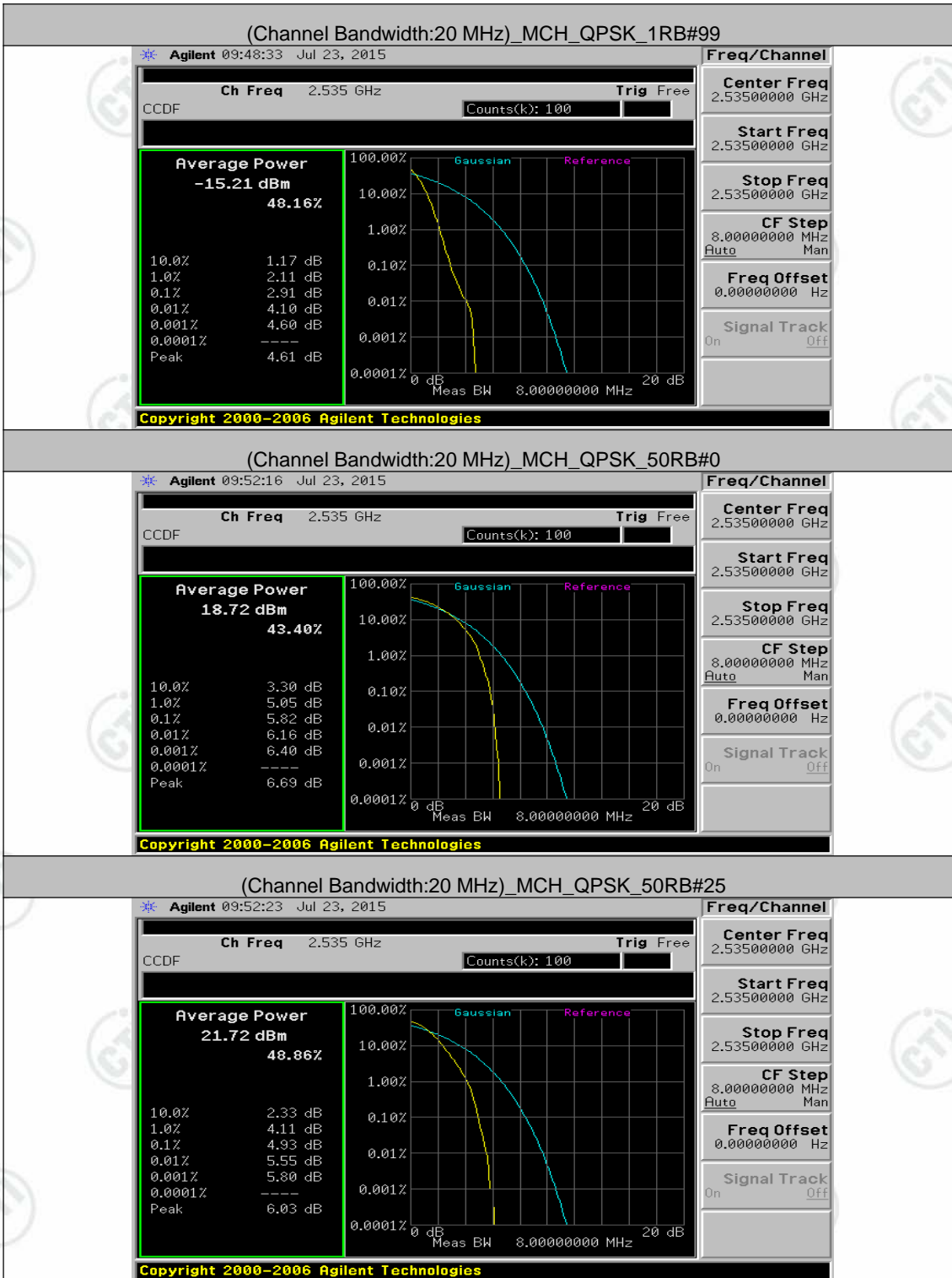

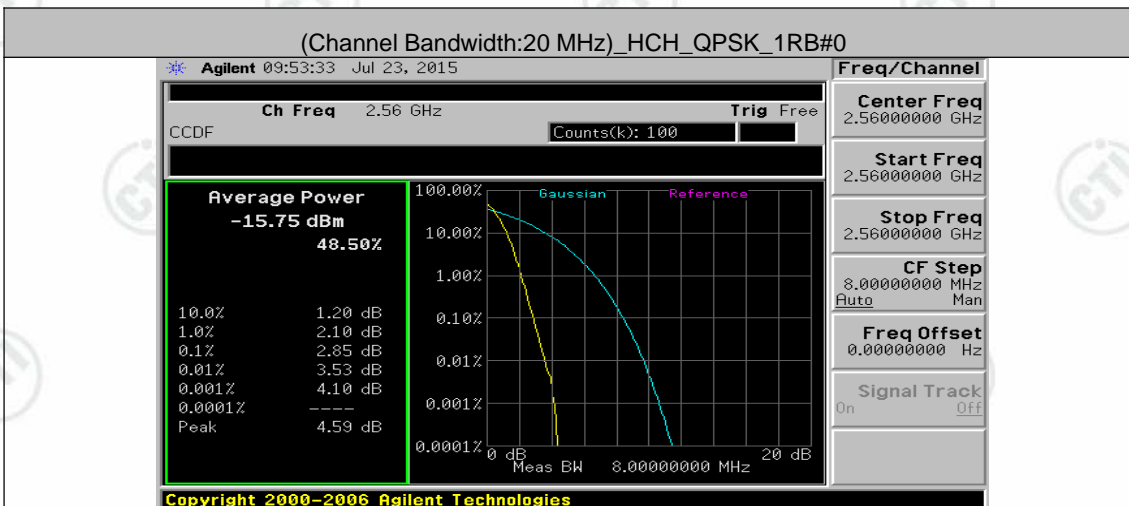
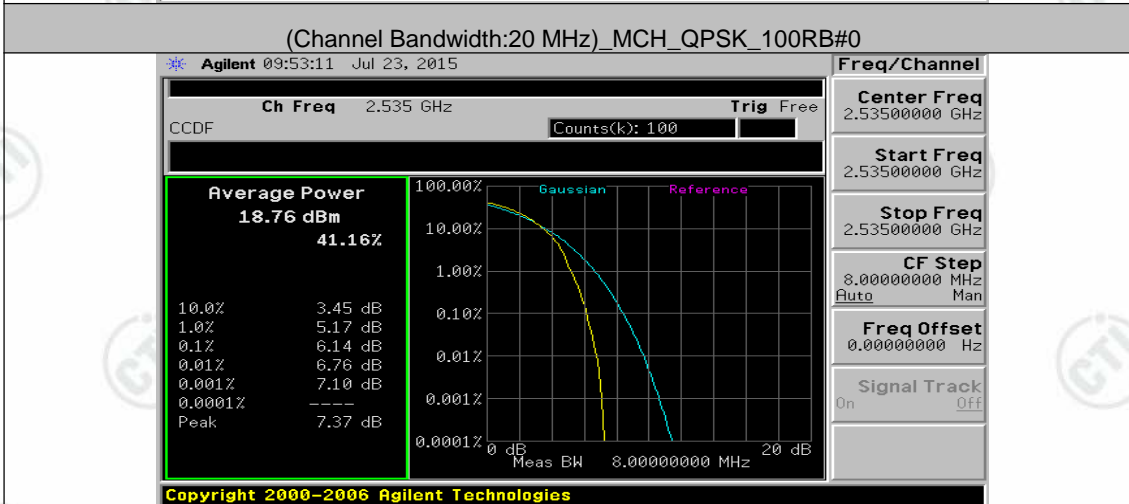
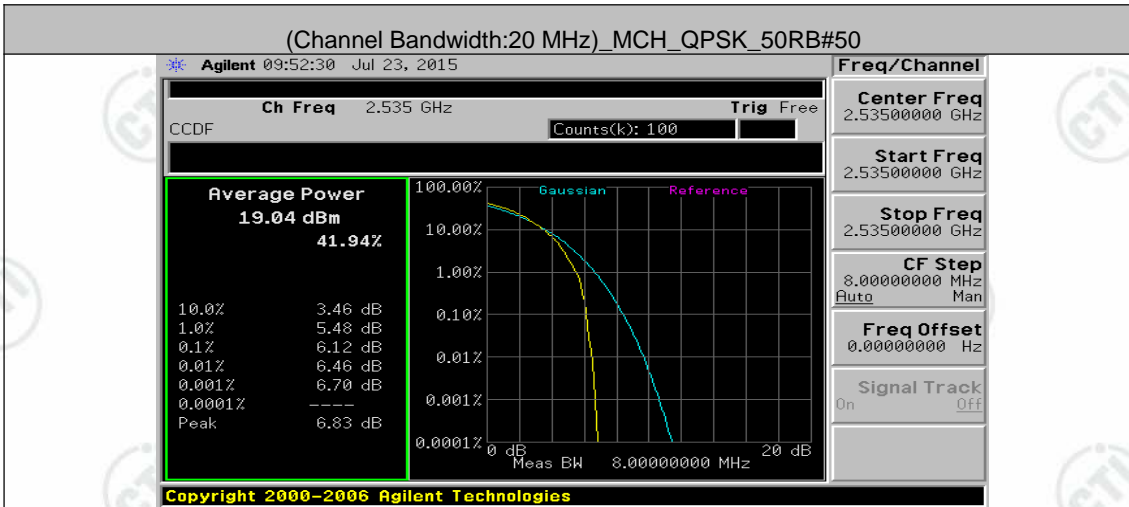









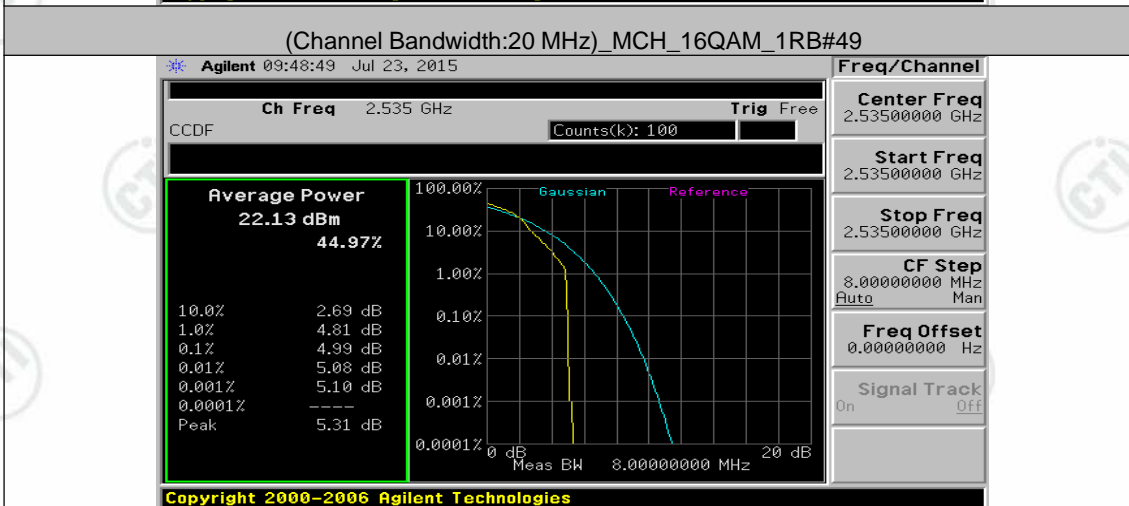
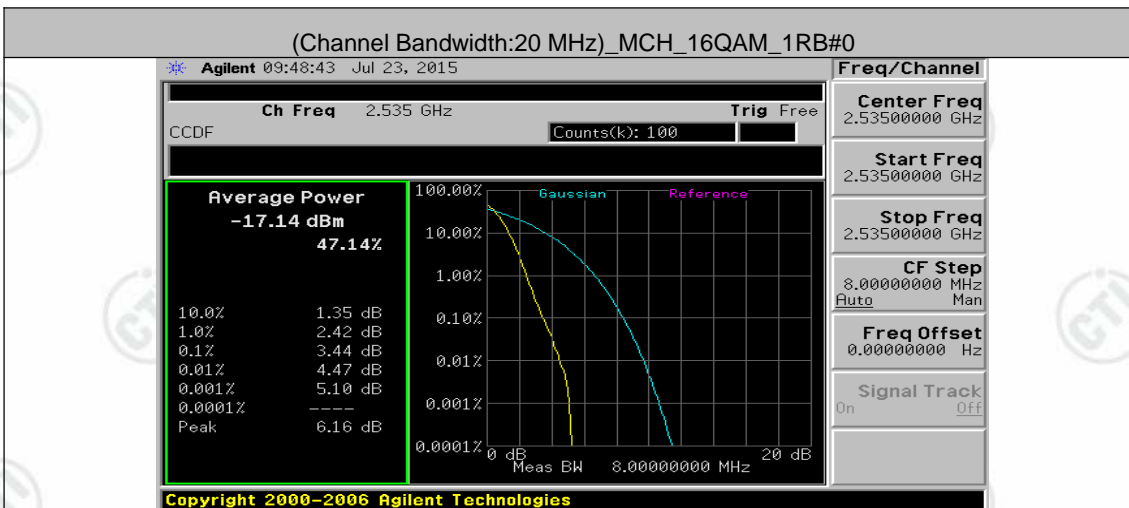
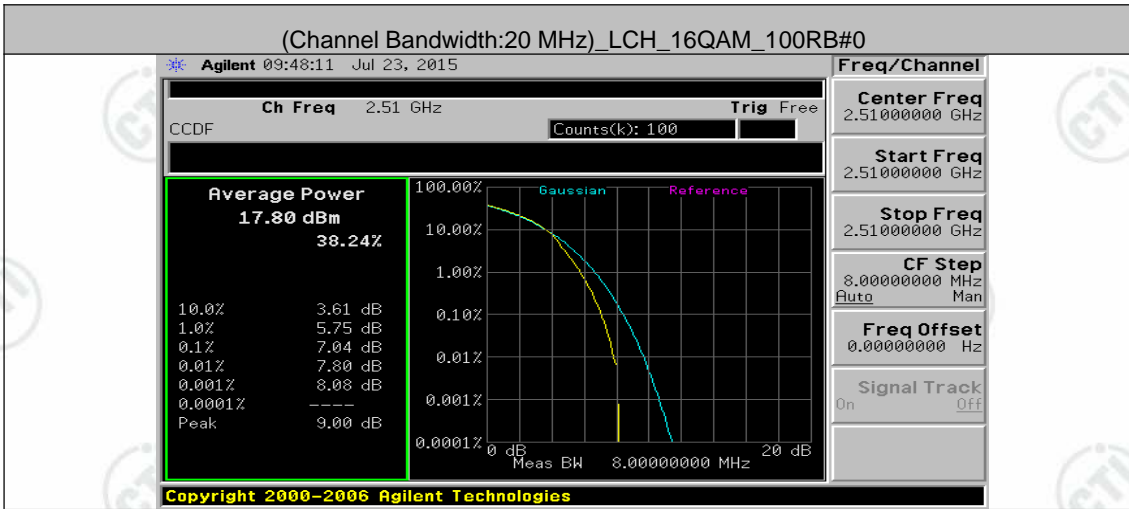

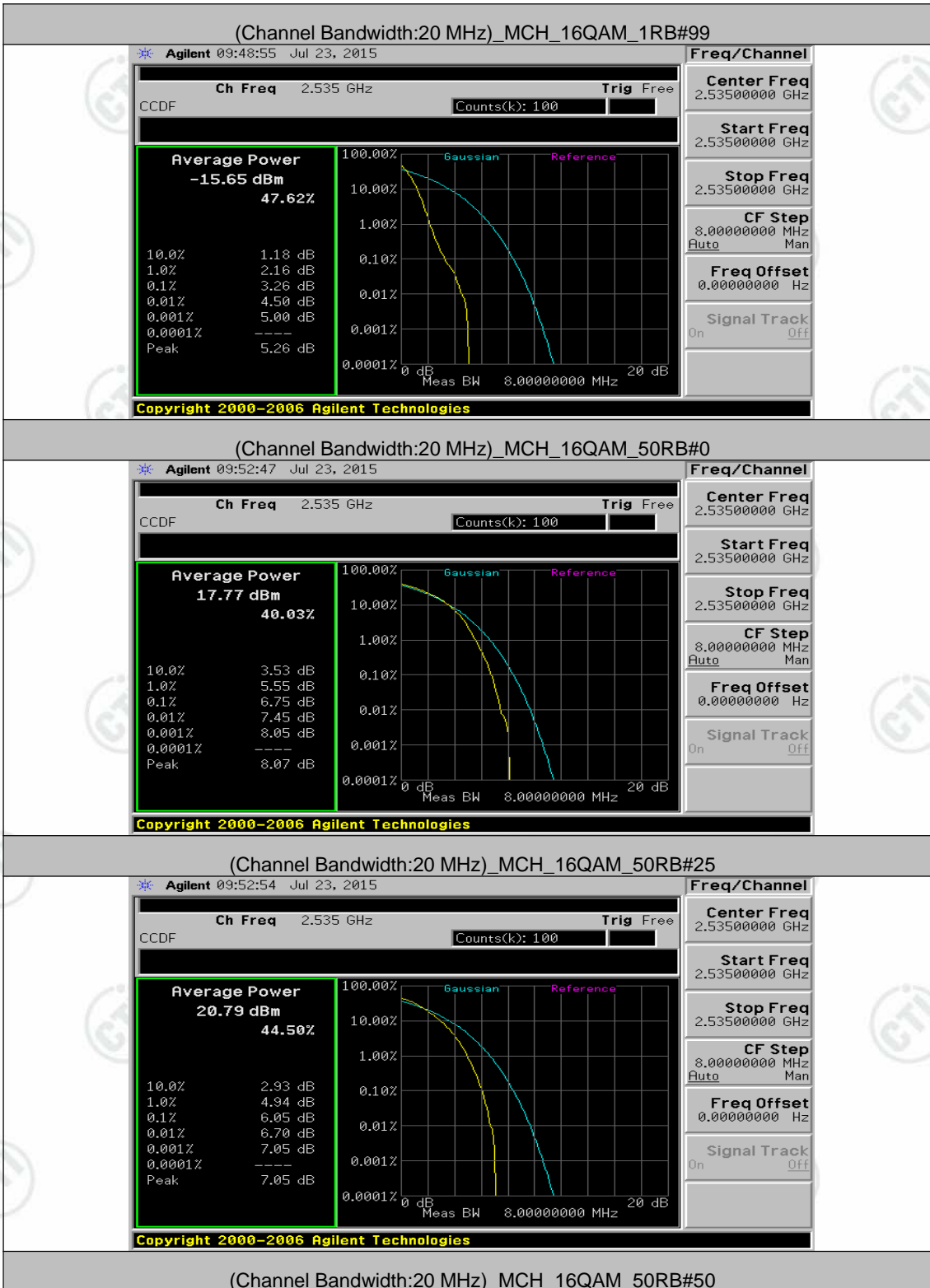

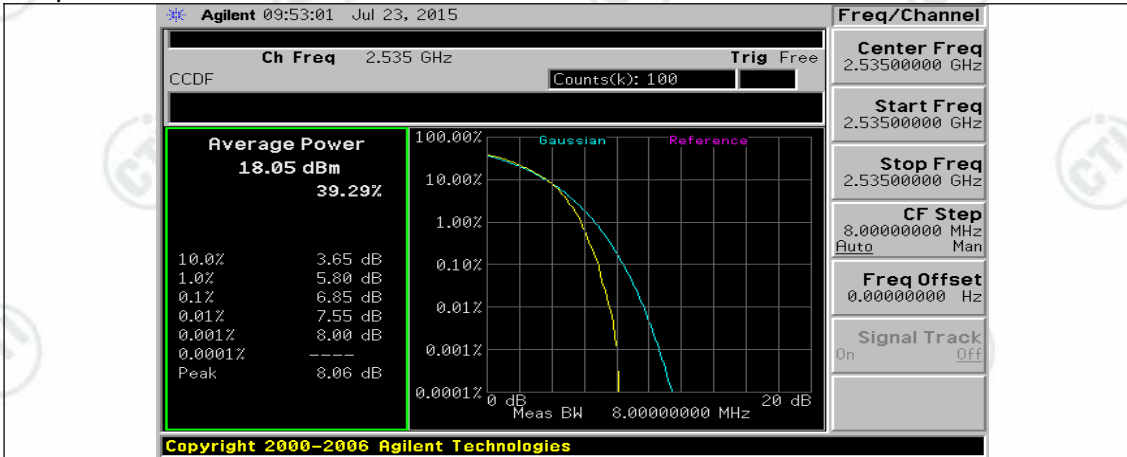

(Channel Bandwidth:20 MHz)_MCH_16QAM_100RB#0

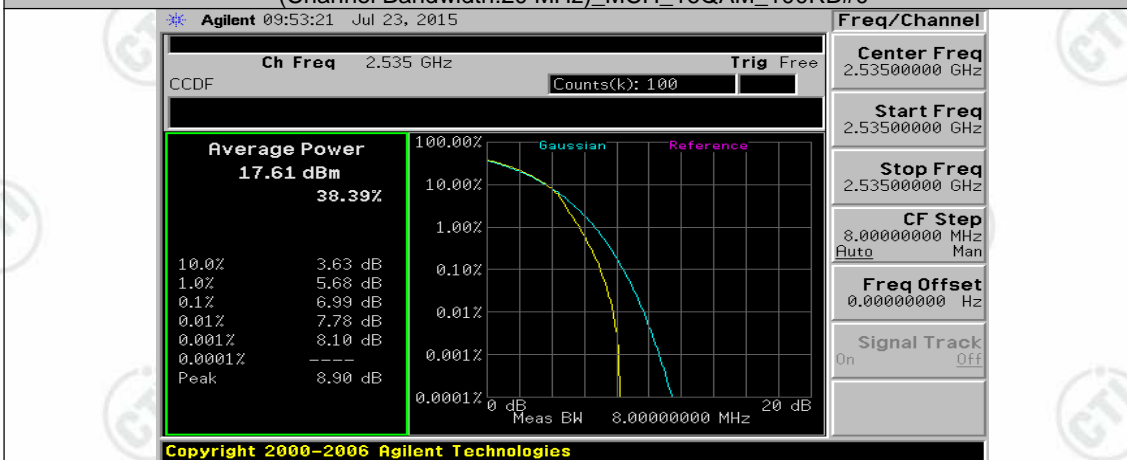

(Channel Bandwidth:20 MHz)_HCH_16QAM_1RB#0

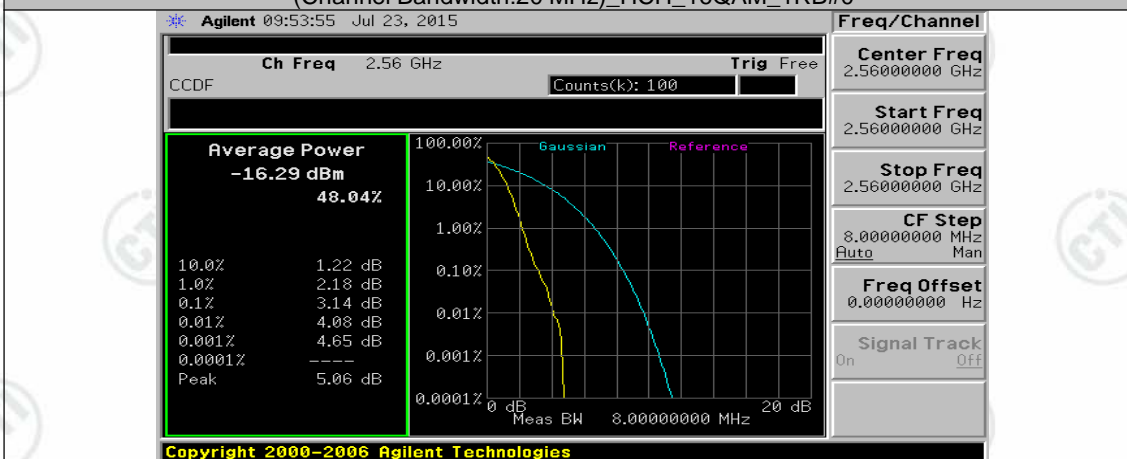



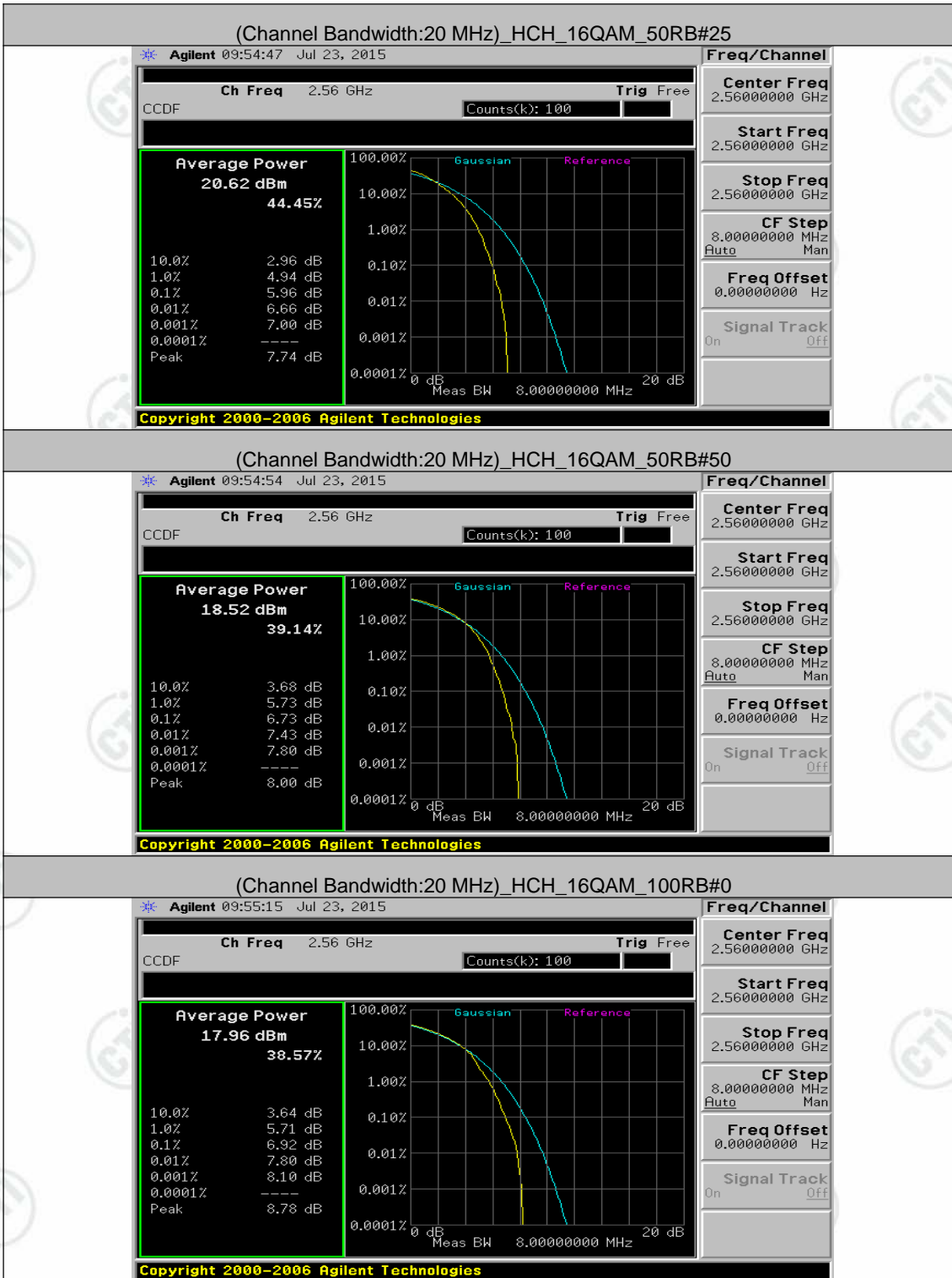

Appendix C: 26dB Bandwidth and Occupied Bandwidth

Test Graphs

Channel Bandwidth: 5 MHz

Channel Bandwidth: 5 MHz						
Modulation	Channel	RB Configuration		Occupied Bandwidth (MHz)	26dB Bandwidth (MHz)	Verdict
		Size	Offset			
QPSK	LCH	25	0	4.4752	4.953	PASS
	MCH	25	0	4.4721	4.954	PASS
	HCH	25	0	4.4758	4.968	PASS
16QAM	LCH	25	0	4.4790	4.967	PASS
	MCH	25	0	4.4794	4.960	PASS
	HCH	25	0	4.4813	4.951	PASS

Channel Bandwidth: 10 MHz

Channel Bandwidth: 10 MHz						
Modulation	Channel	RB Configuration		Occupied Bandwidth (MHz)	26dB Bandwidth (MHz)	Verdict
		Size	Offset			
QPSK	LCH	50	0	8.9288	9.753	PASS
	MCH	50	0	8.9238	9.756	PASS
	HCH	50	0	8.9300	9.767	PASS
16QAM	LCH	50	0	8.9312	9.789	PASS
	MCH	50	0	8.9264	9.759	PASS
	HCH	50	0	8.9148	9.760	PASS

Channel Bandwidth: 15 MHz

Channel Bandwidth: 15 MHz						
Modulation	Channel	RB Configuration		Occupied Bandwidth (MHz)	26dB Bandwidth (MHz)	Verdict
		Size	Offset			
QPSK	LCH	75	0	13.4007	14.489	PASS
	MCH	75	0	13.4102	14.540	PASS
	HCH	75	0	13.3724	14.373	PASS
16QAM	LCH	75	0	13.4127	14.438	PASS
	MCH	75	0	13.4289	14.507	PASS
	HCH	75	0	13.3926	14.445	PASS

Channel Bandwidth: 20 MHz

Channel Bandwidth: 20 MHz						
Modulation	Channel	RB Configuration		Occupied Bandwidth (MHz)	26dB Bandwidth (MHz)	Verdict
		Size	Offset			
QPSK	LCH	100	0	17.8349	19.137	PASS
	MCH	100	0	17.8730	19.302	PASS
	HCH	100	0	17.8226	18.959	PASS
16QAM	LCH	100	0	17.8673	19.117	PASS
	MCH	100	0	17.8692	19.250	PASS
	HCH	100	0	17.8033	19.025	PASS

Test Graphs

Channel Bandwidth: 5 MHz

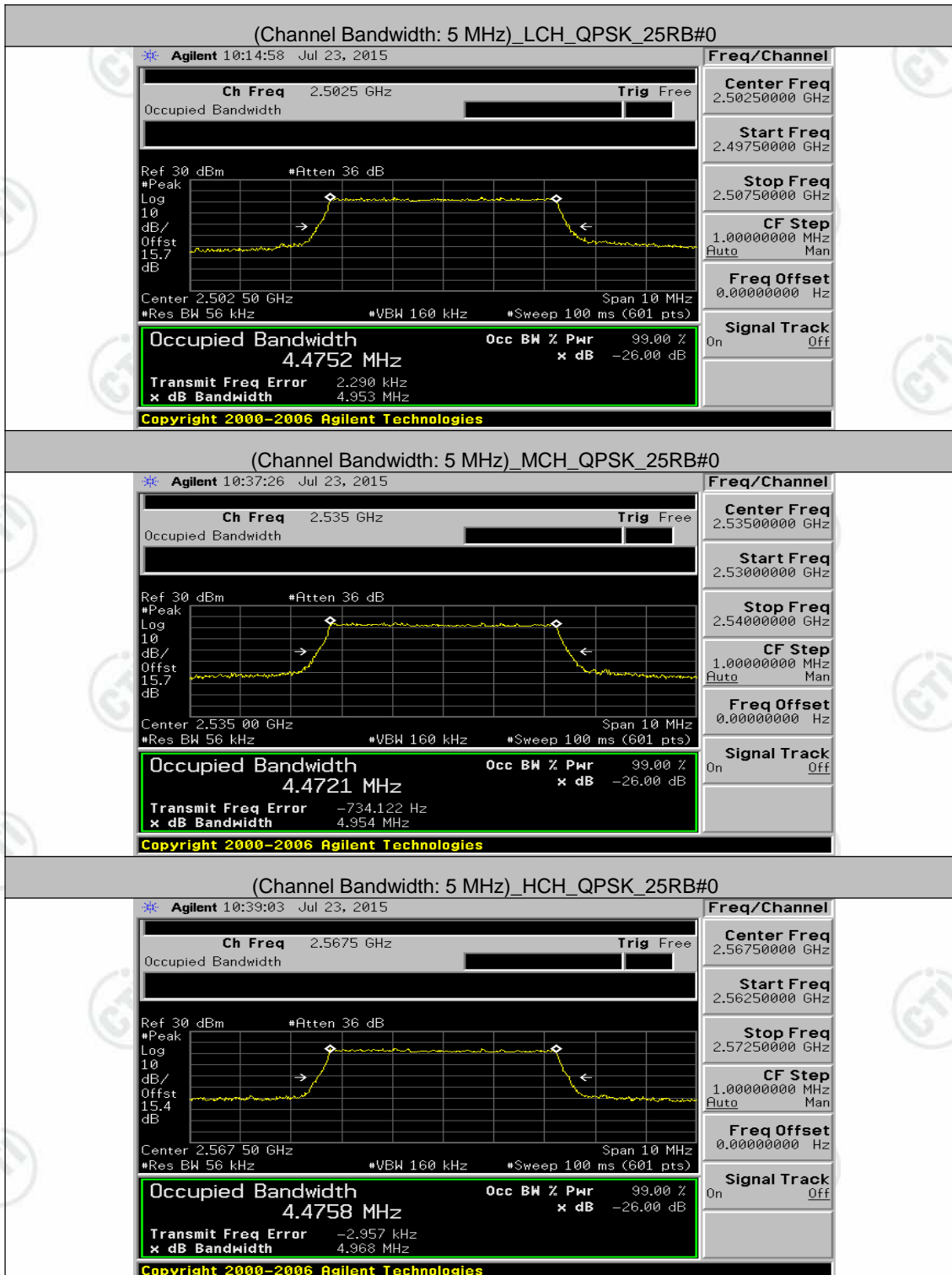

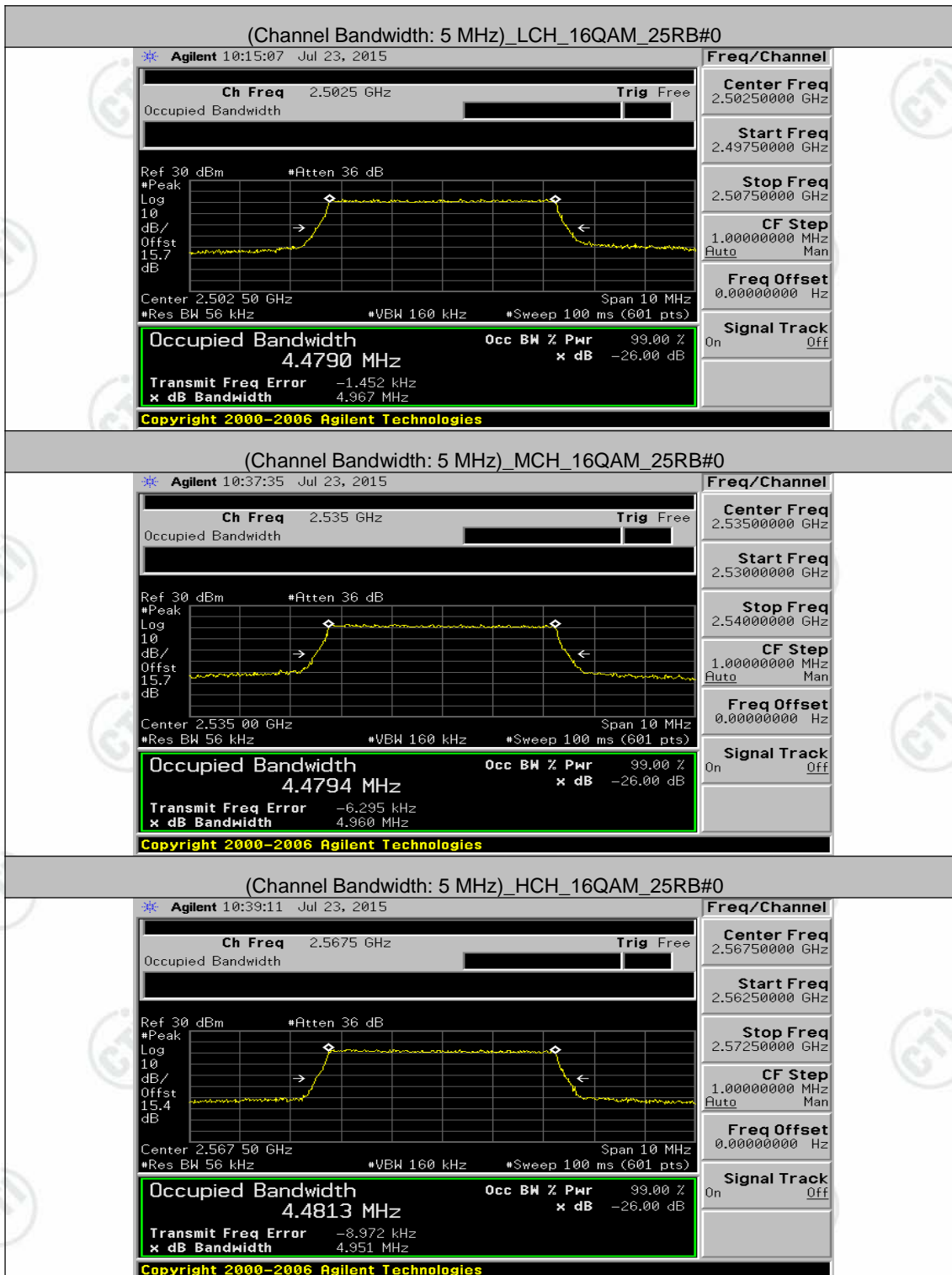

Channel Bandwidth: 10 MHz

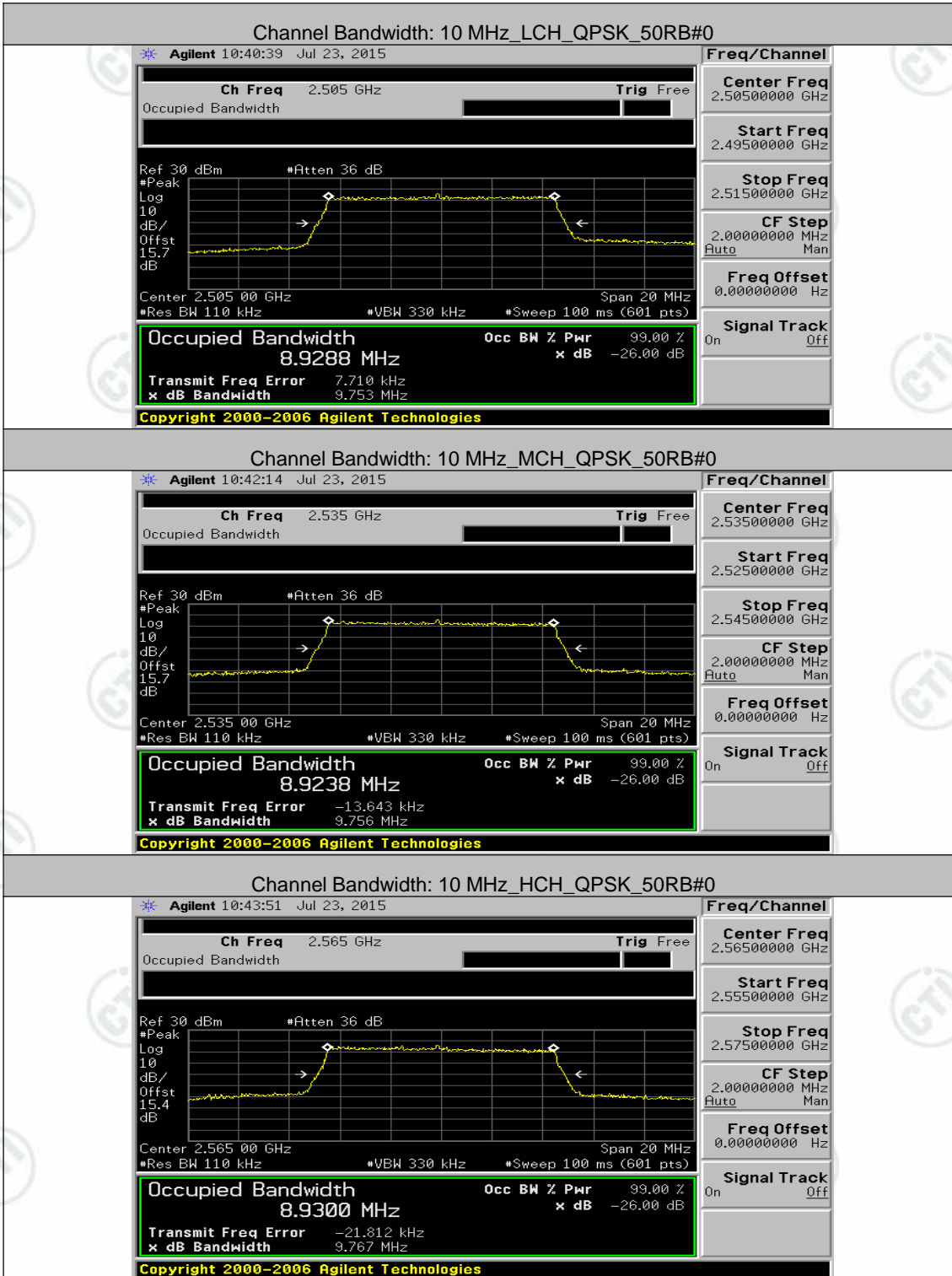

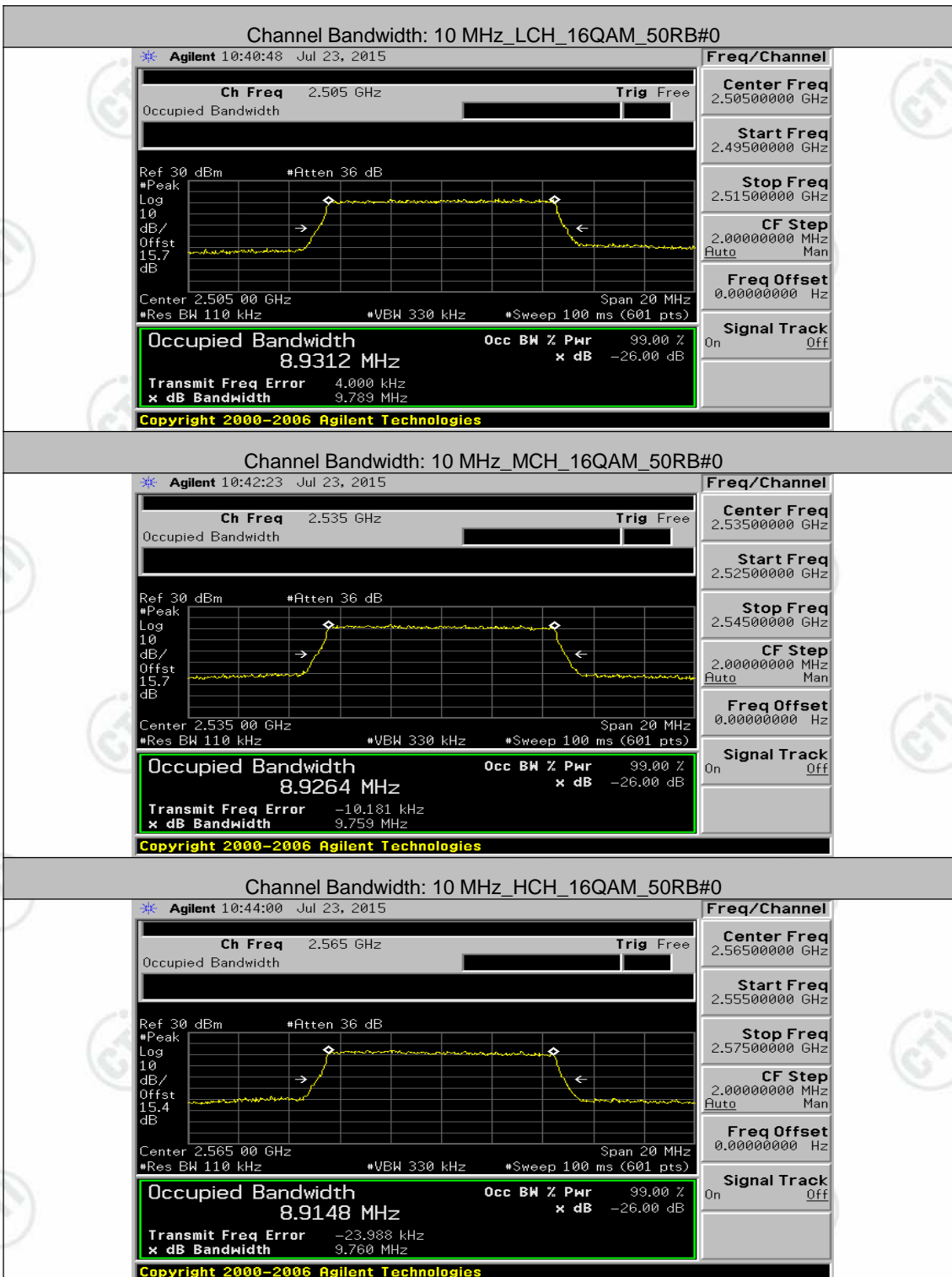

Channel Bandwidth: 15 MHz

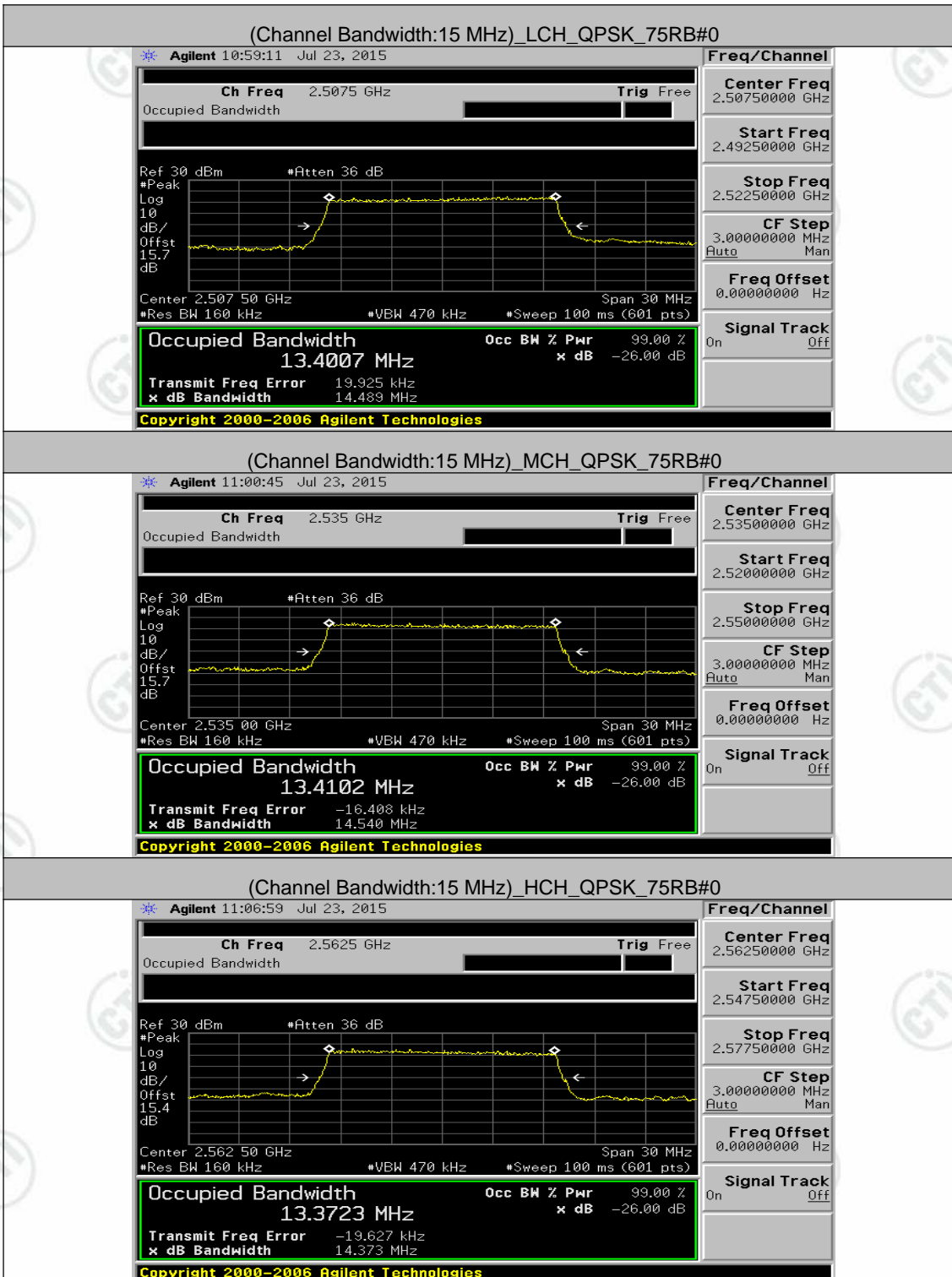

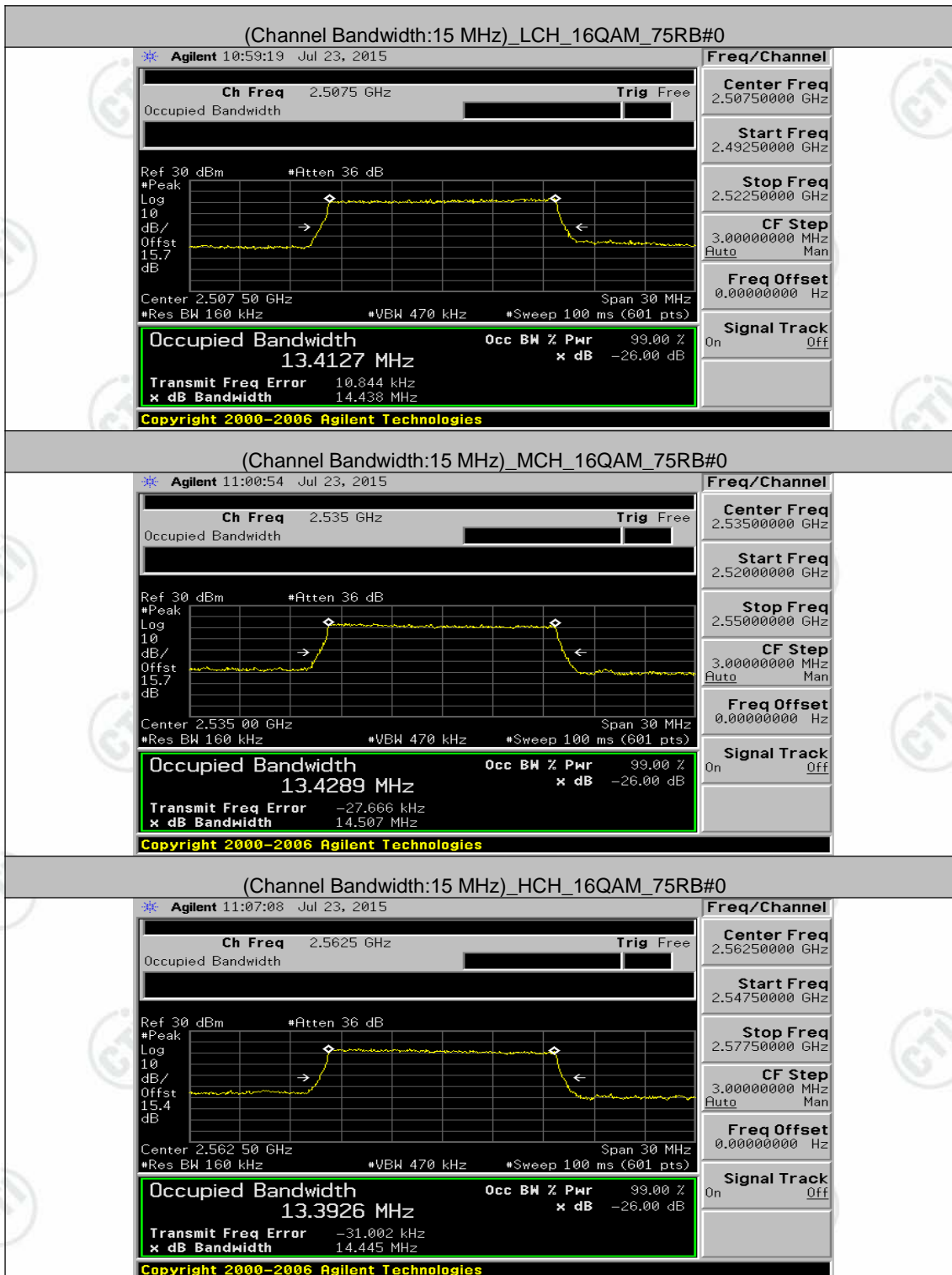

Channel Bandwidth: 20 MHz

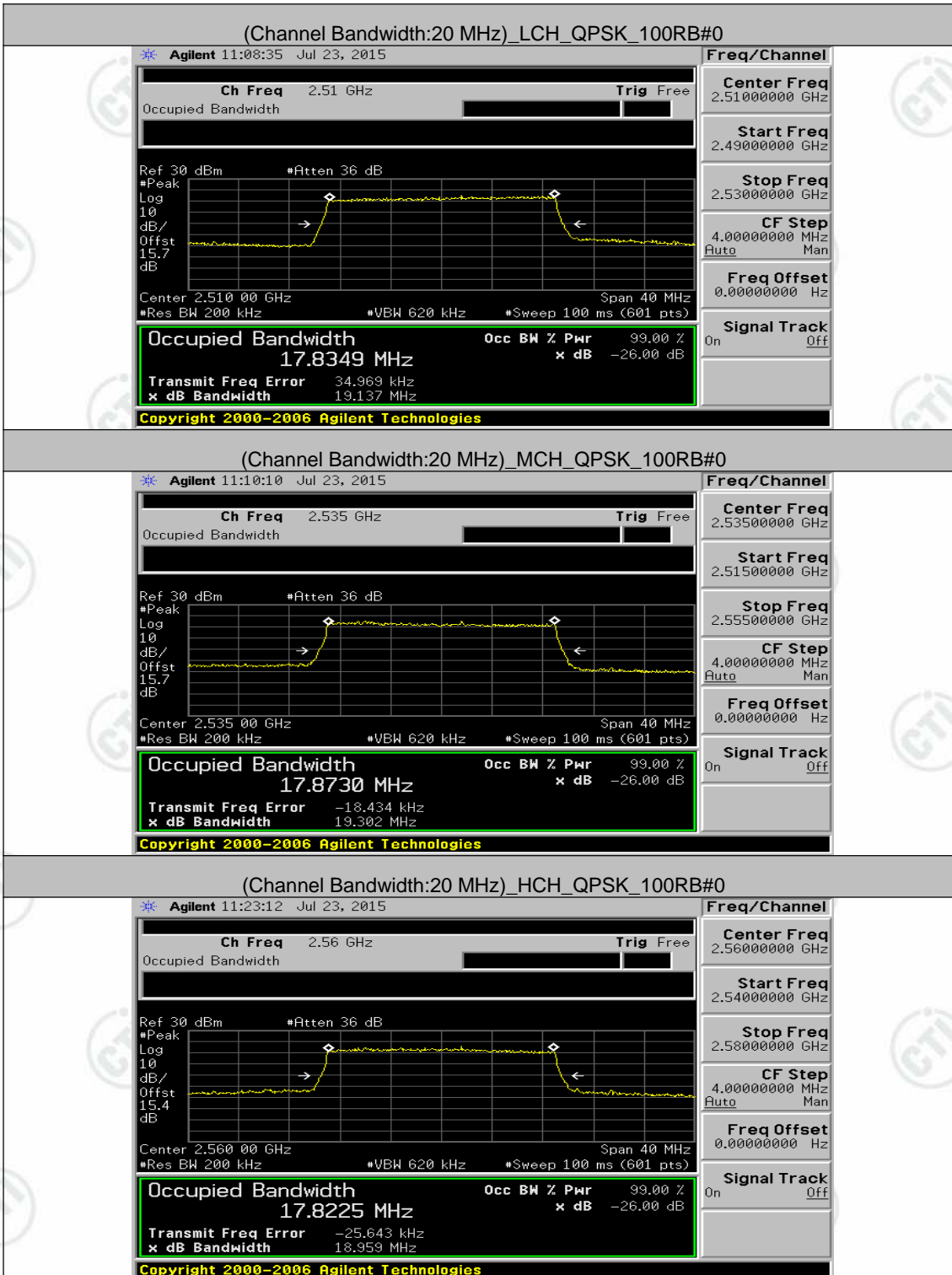

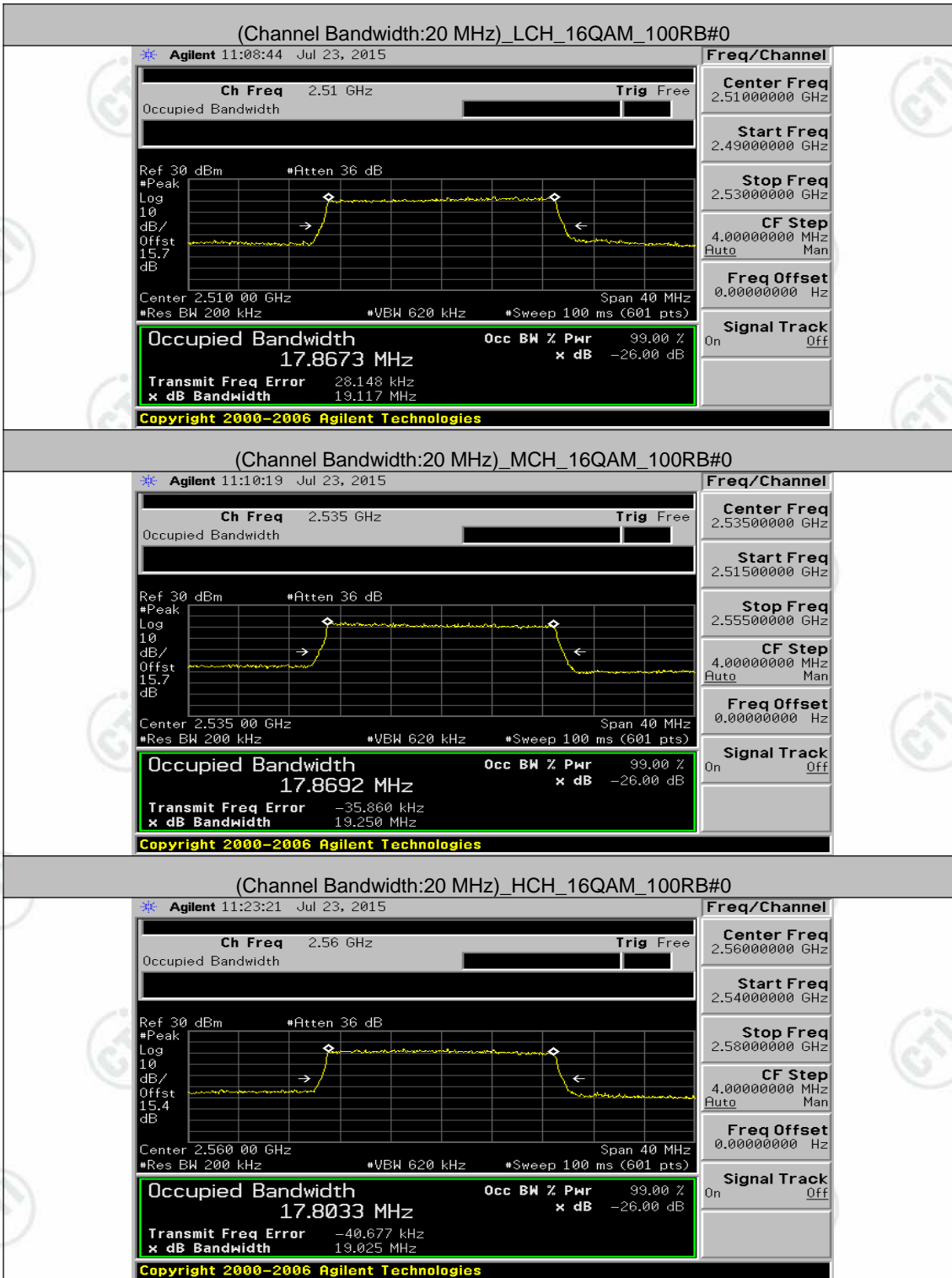

Appendix D: Band Edge

Test Graphs

Channel Bandwidth: 5 MHz

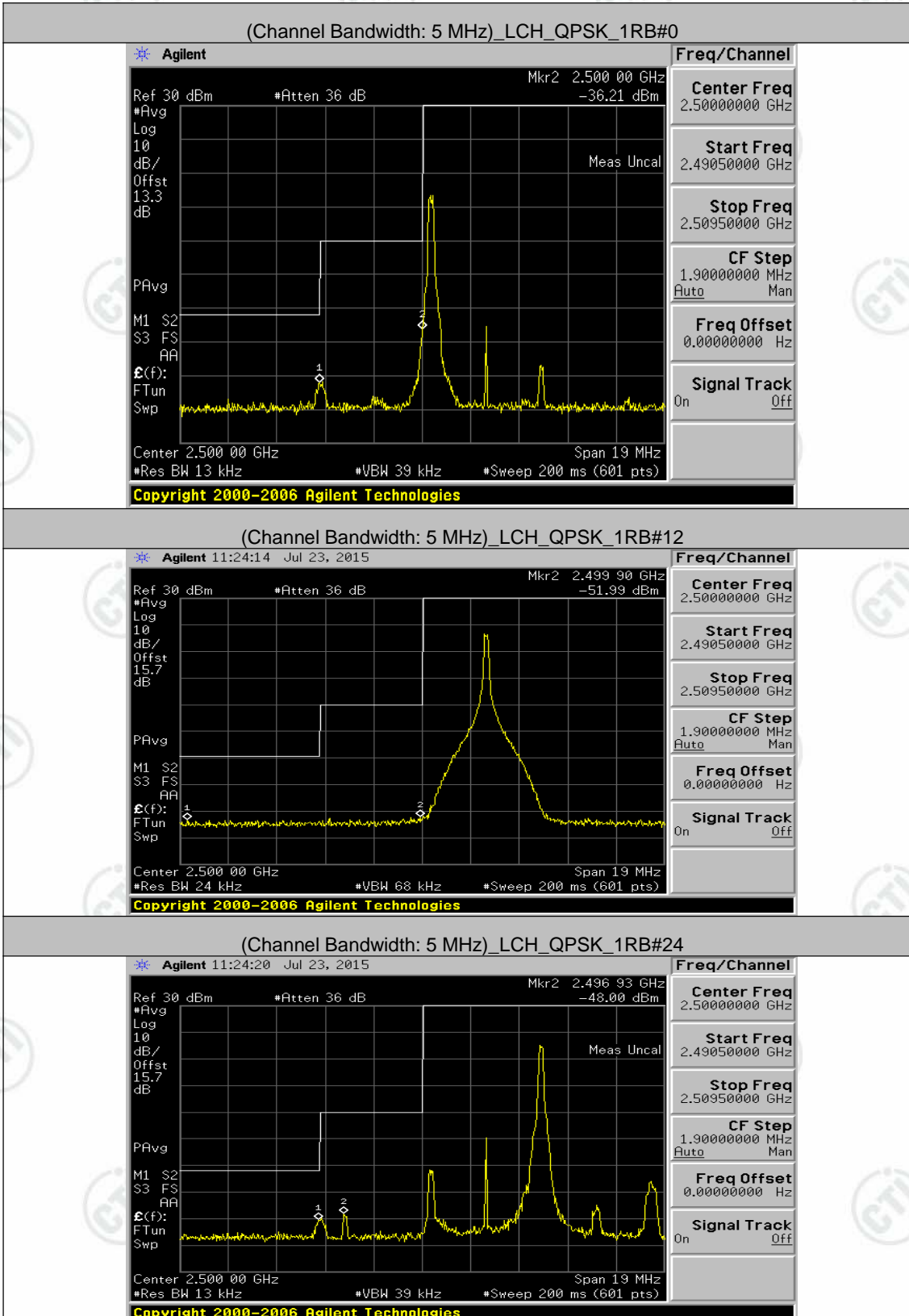

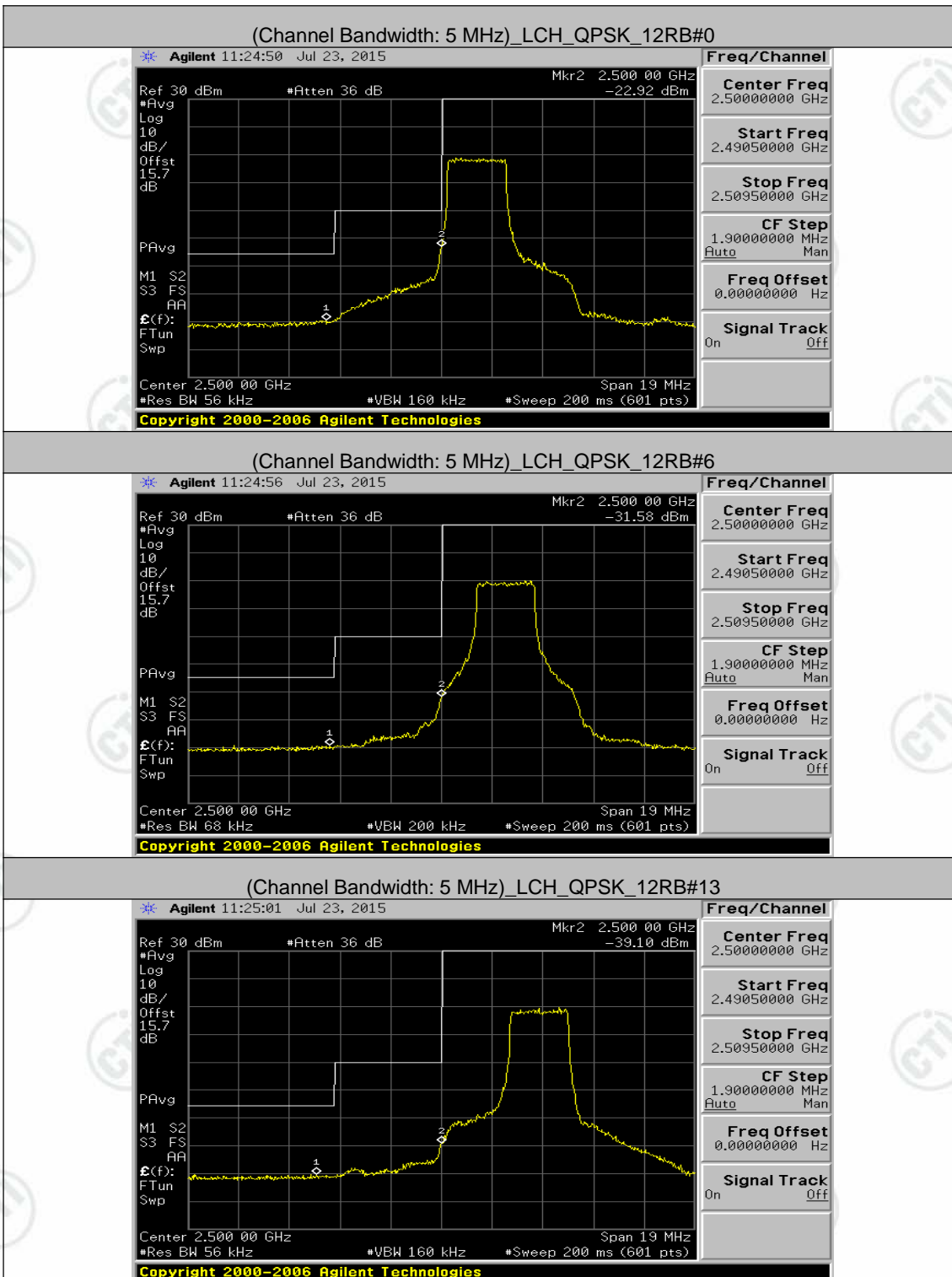

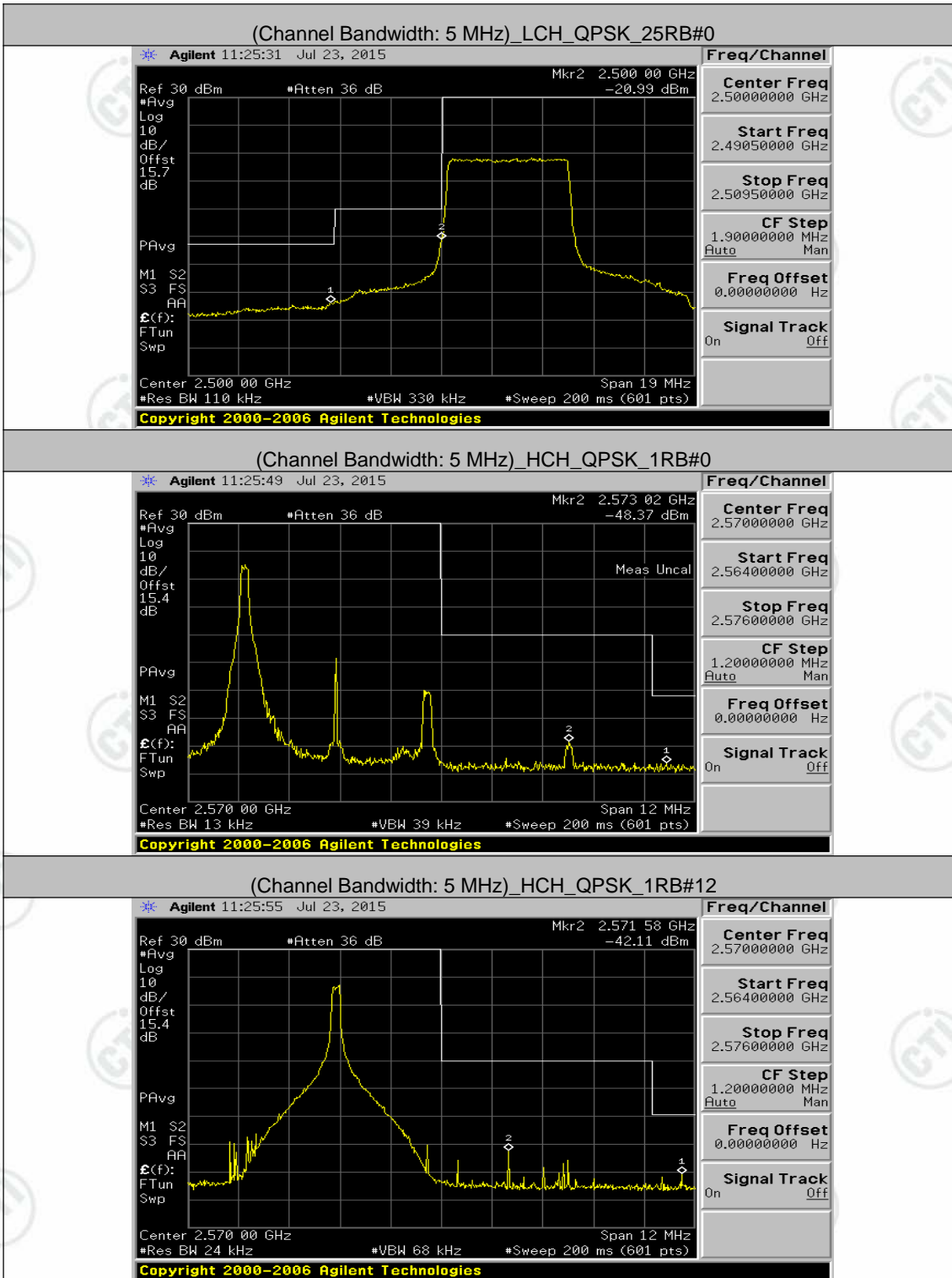

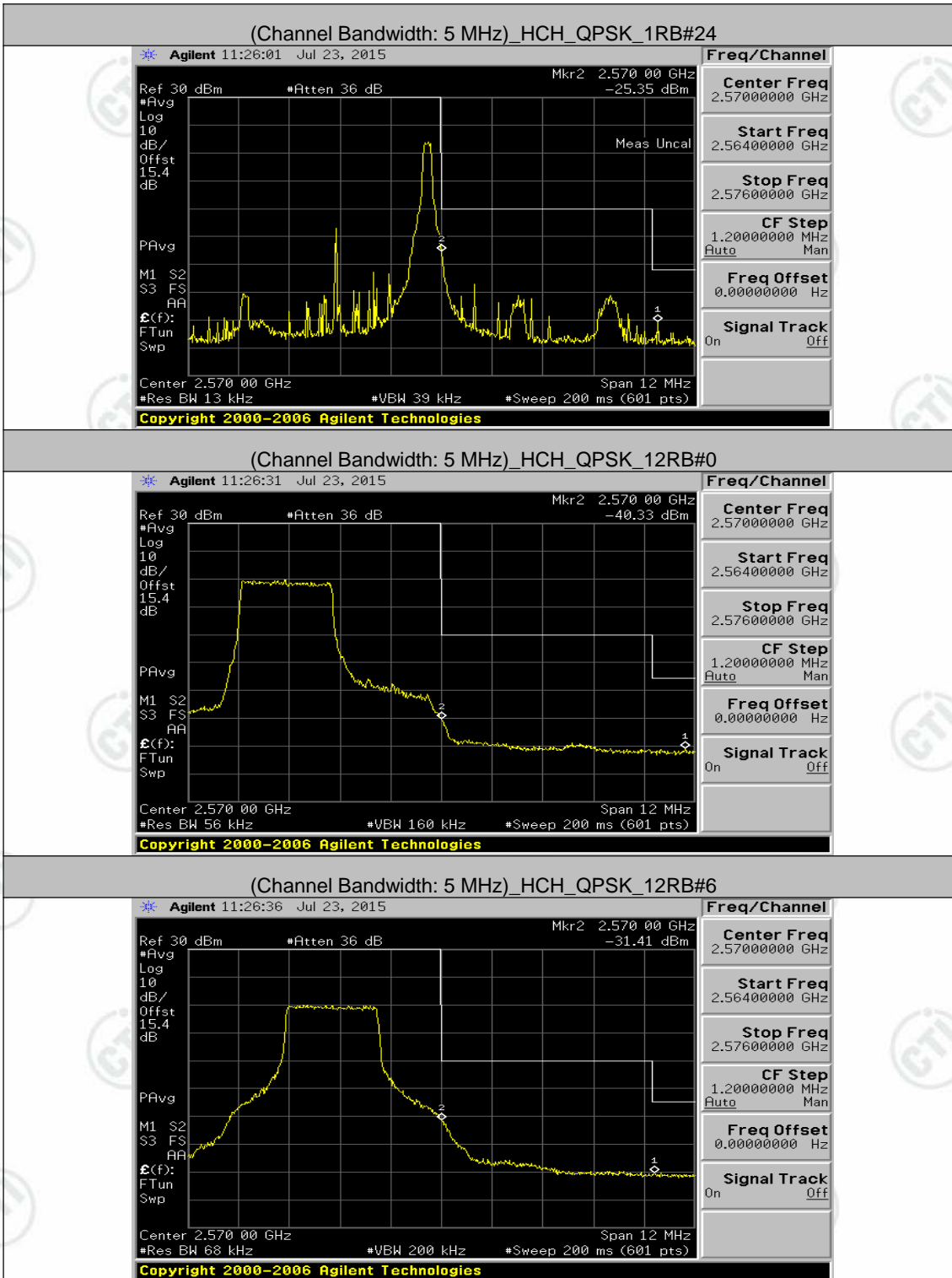

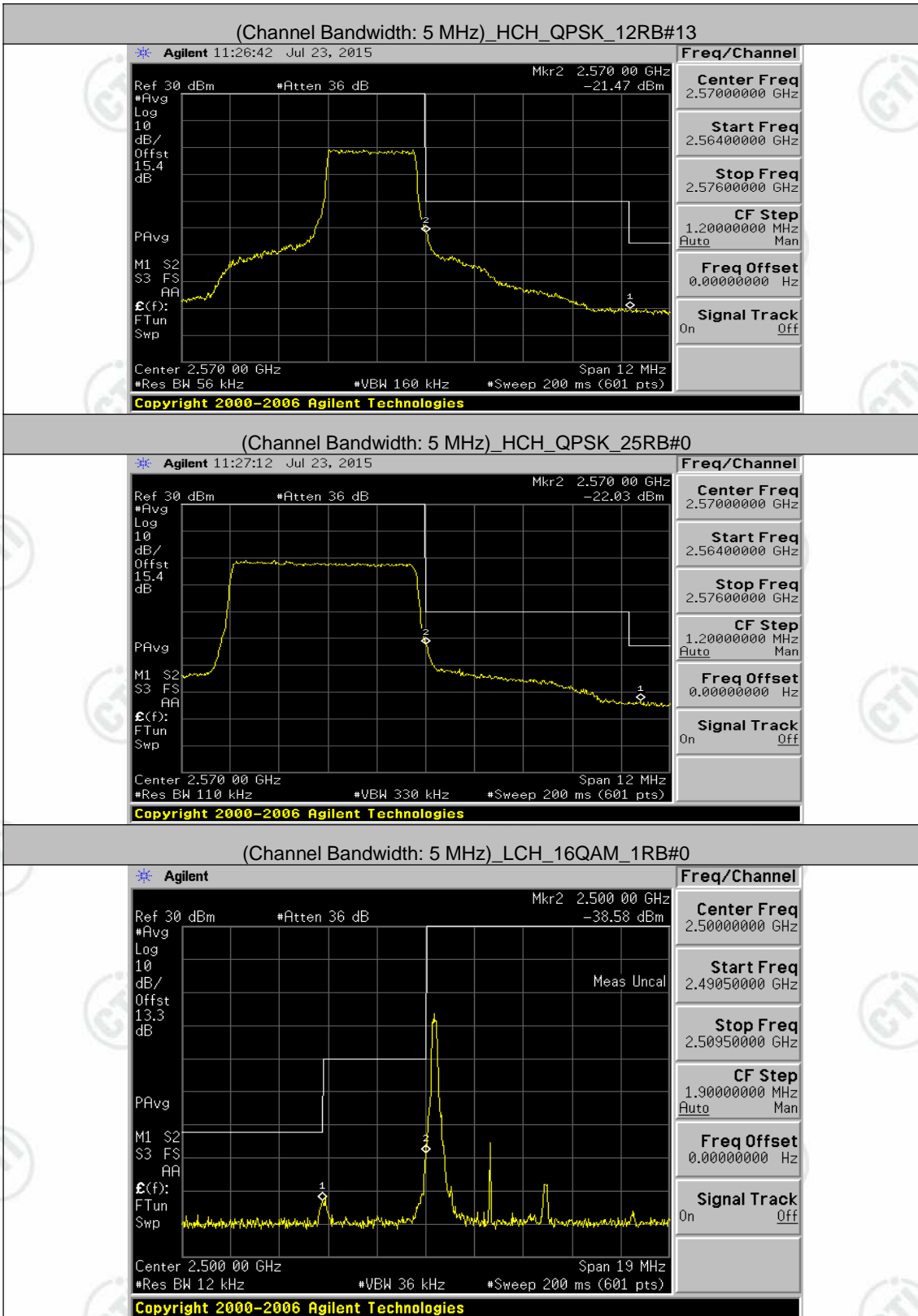

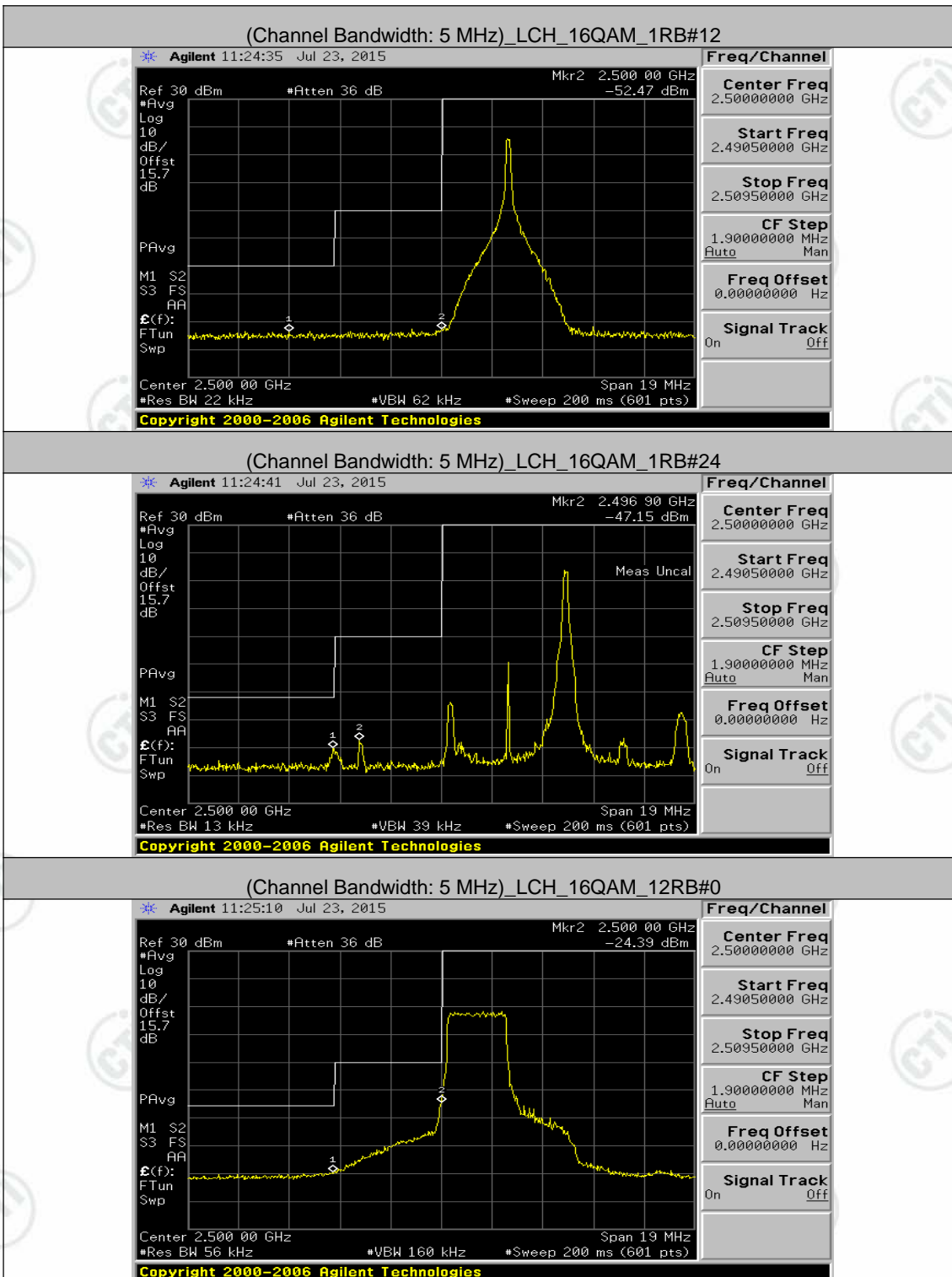

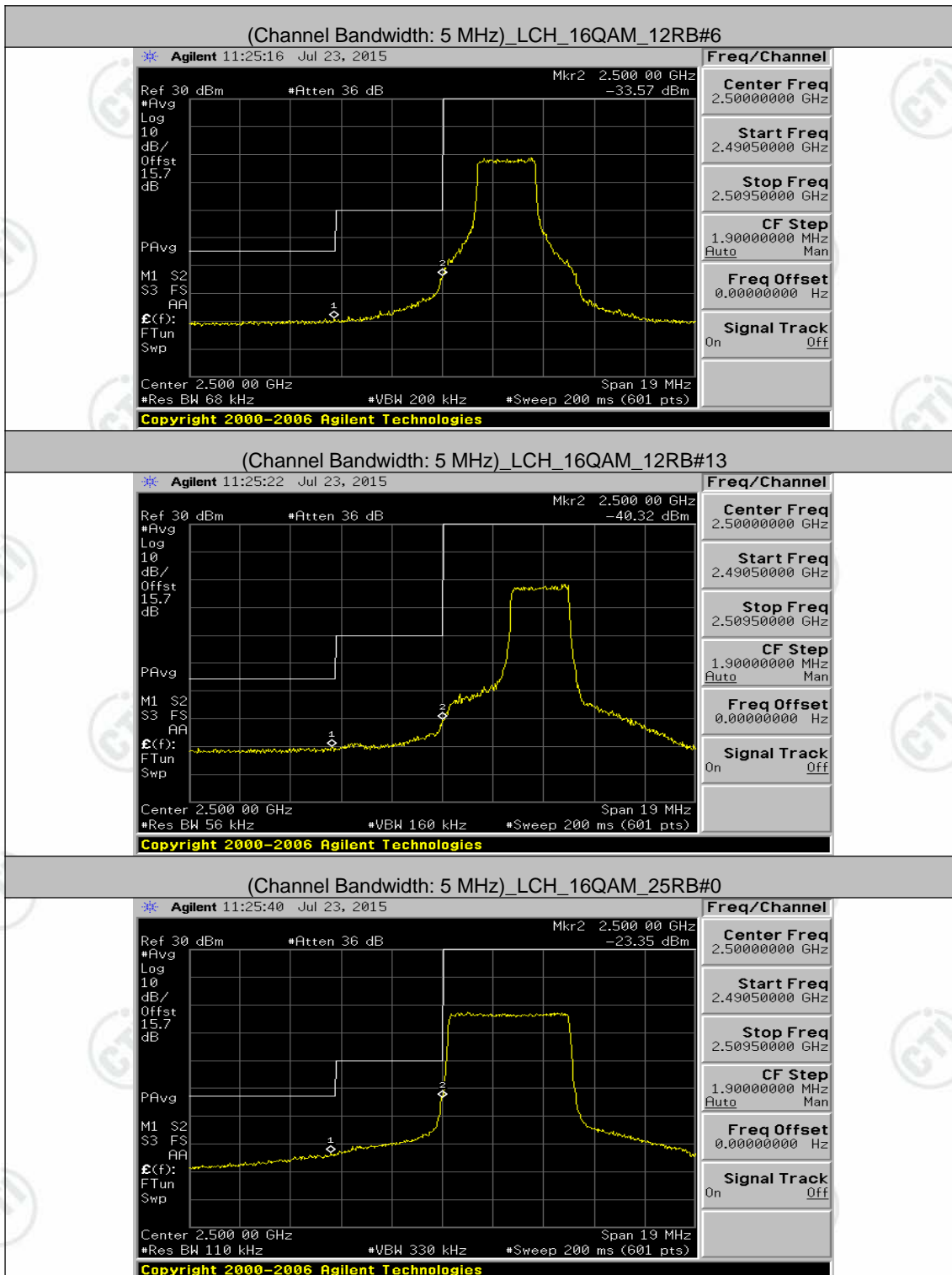

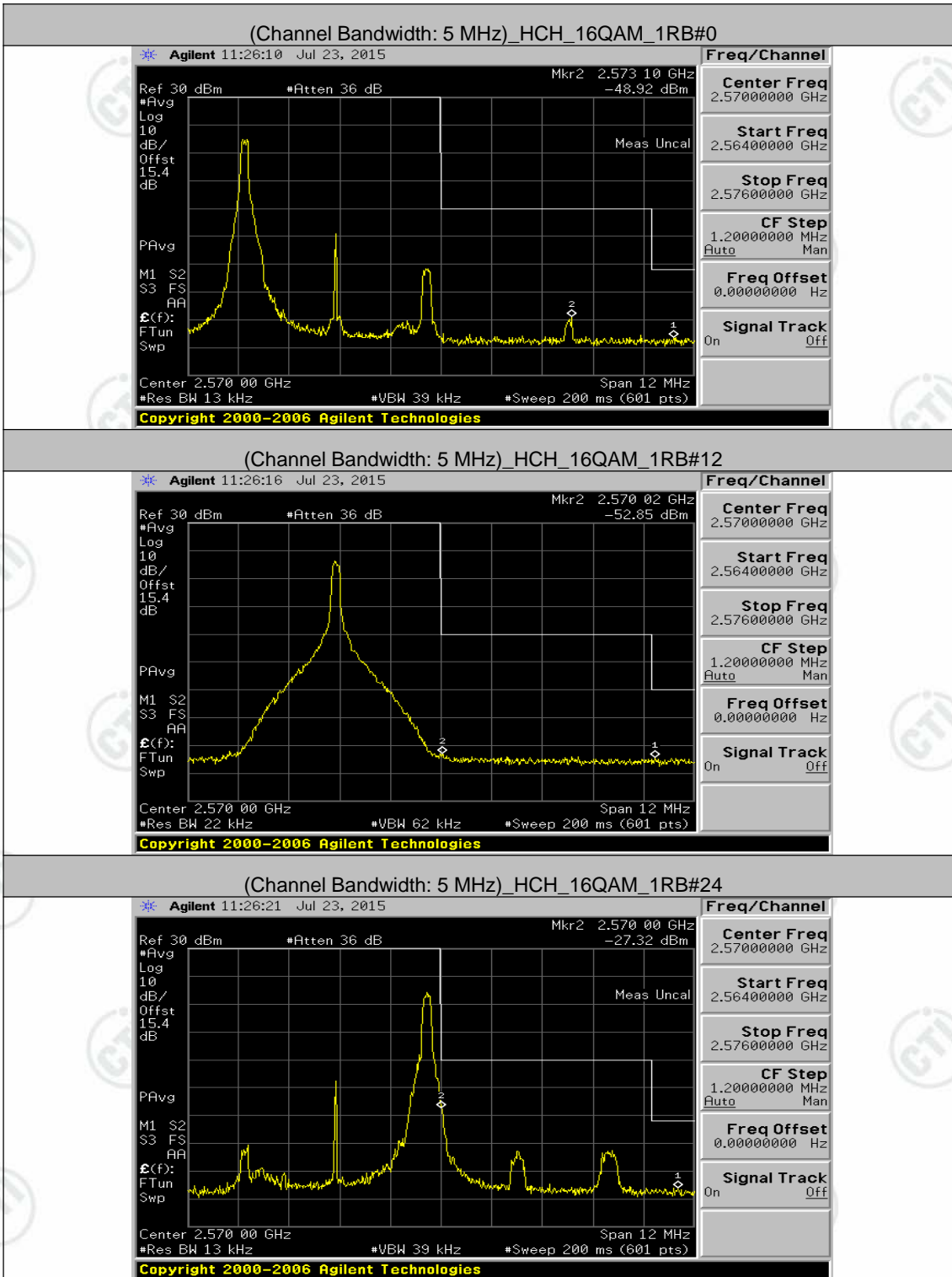

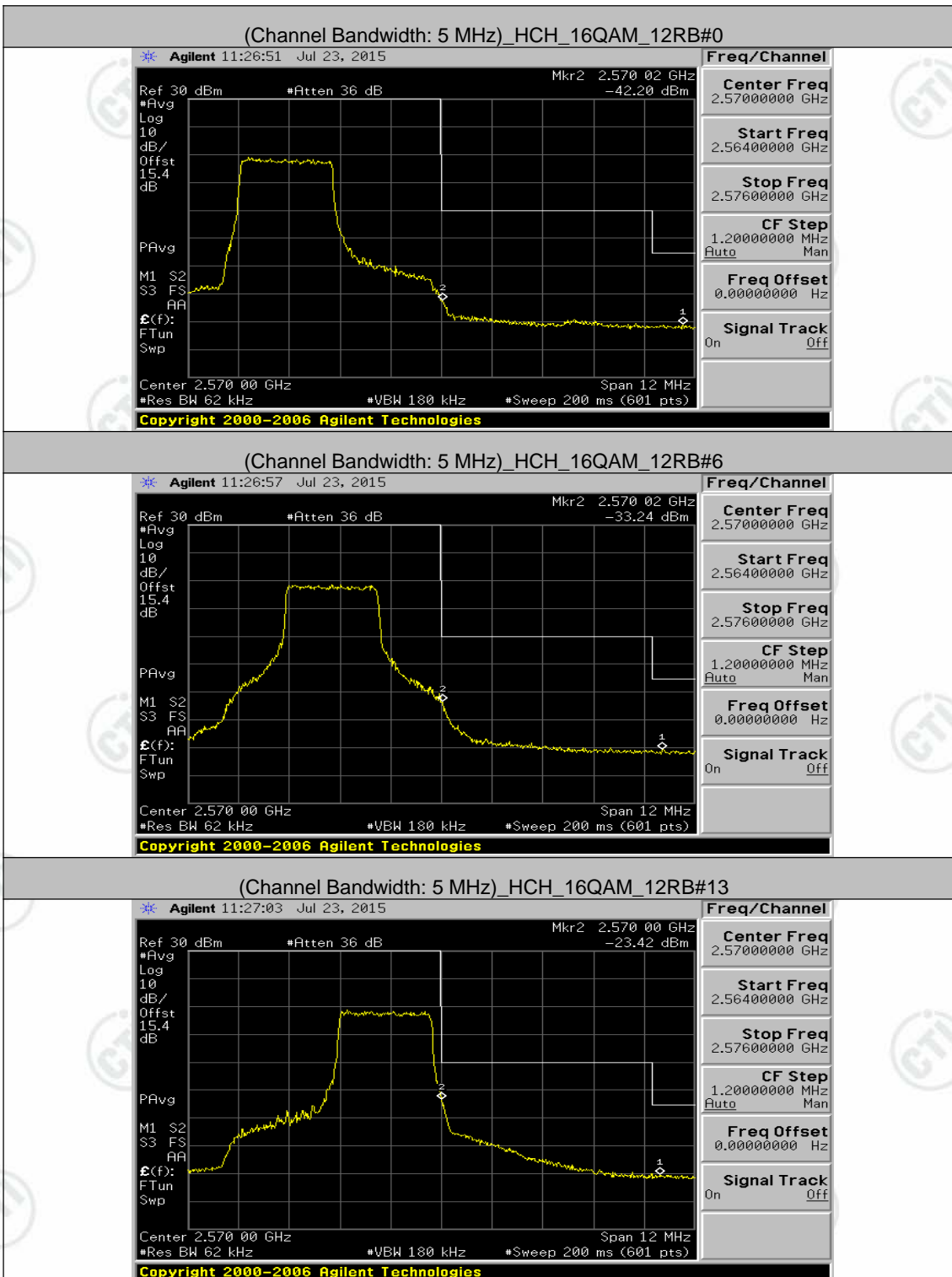

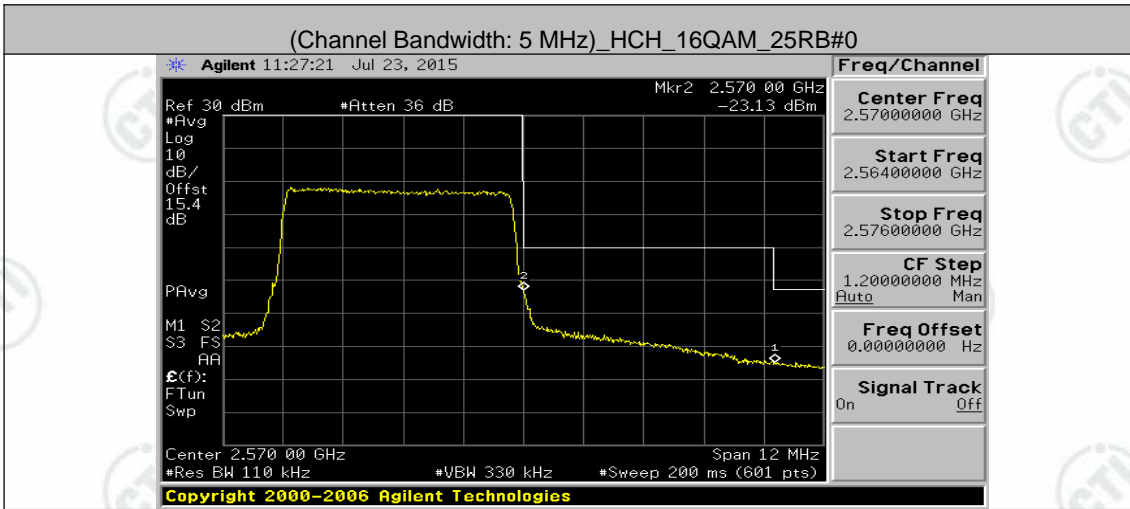

Channel Bandwidth: 10 MHz

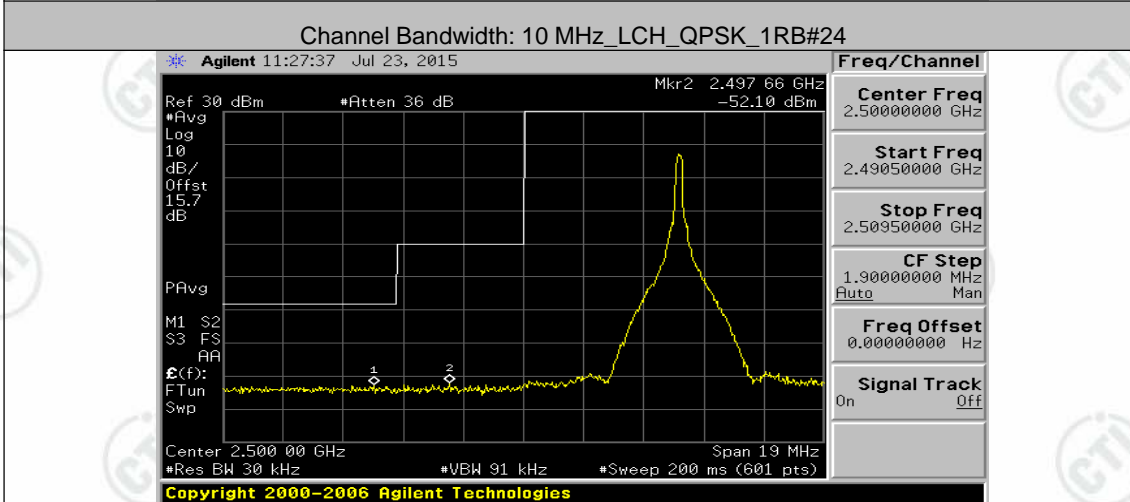
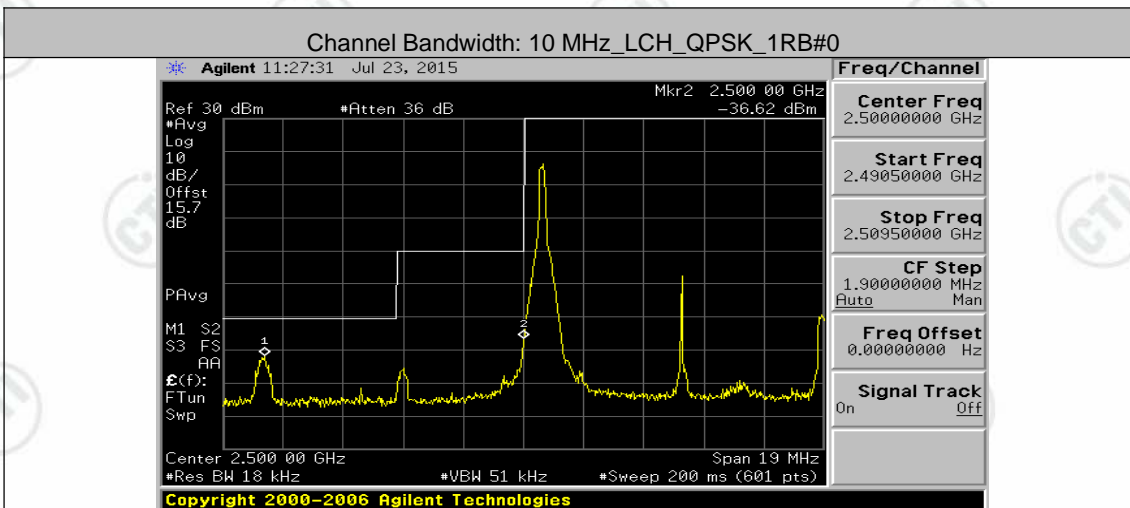

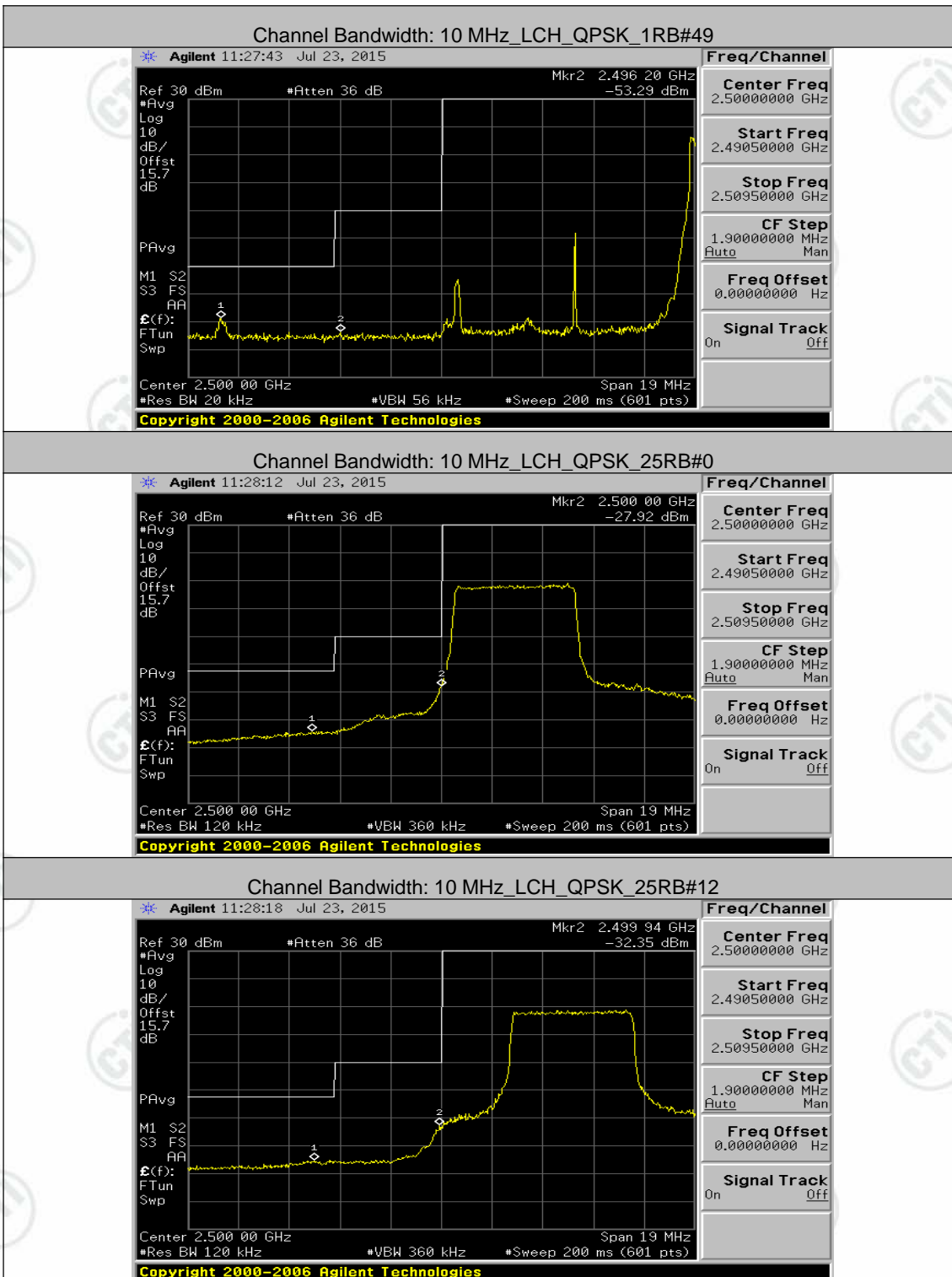

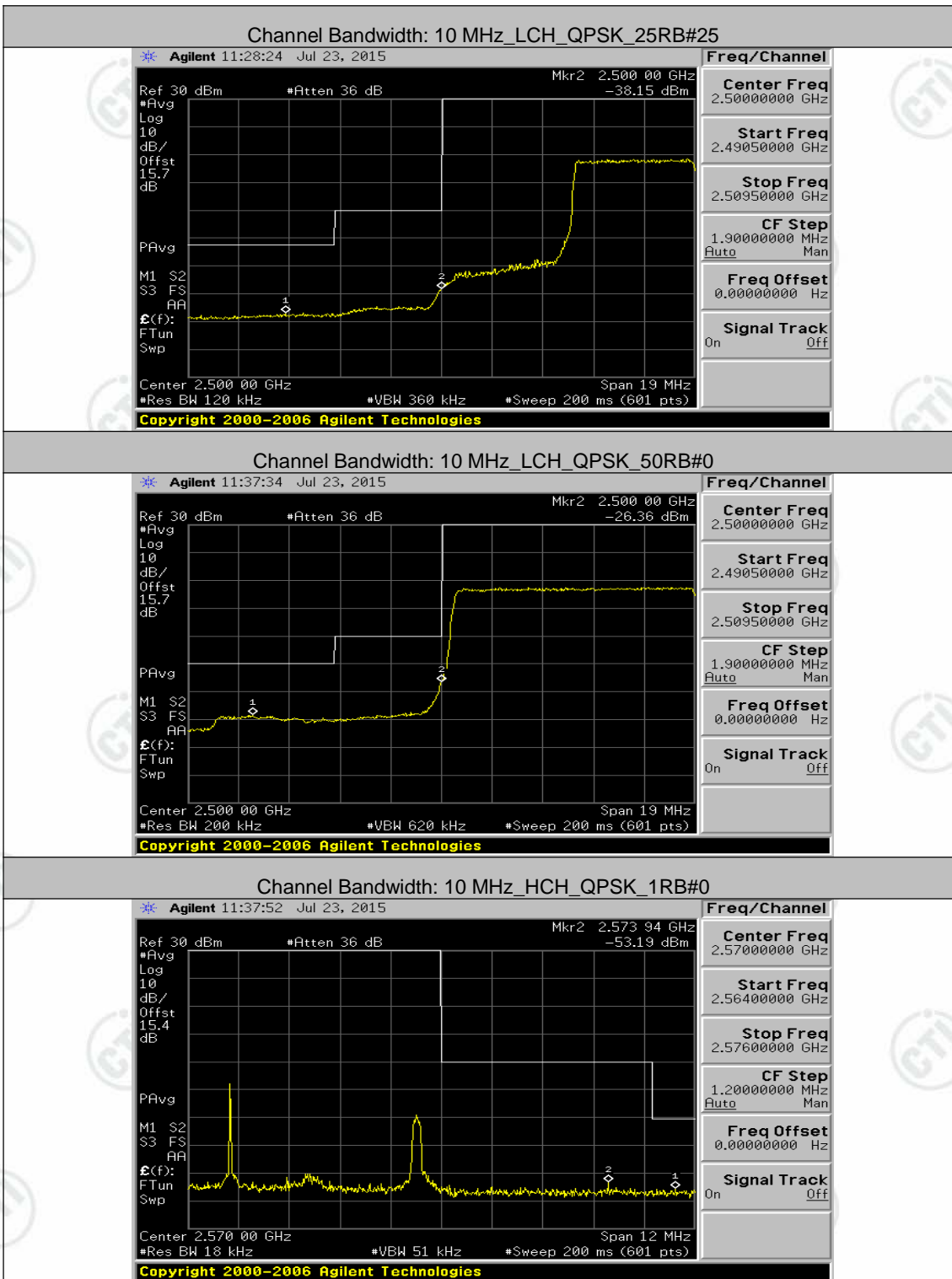

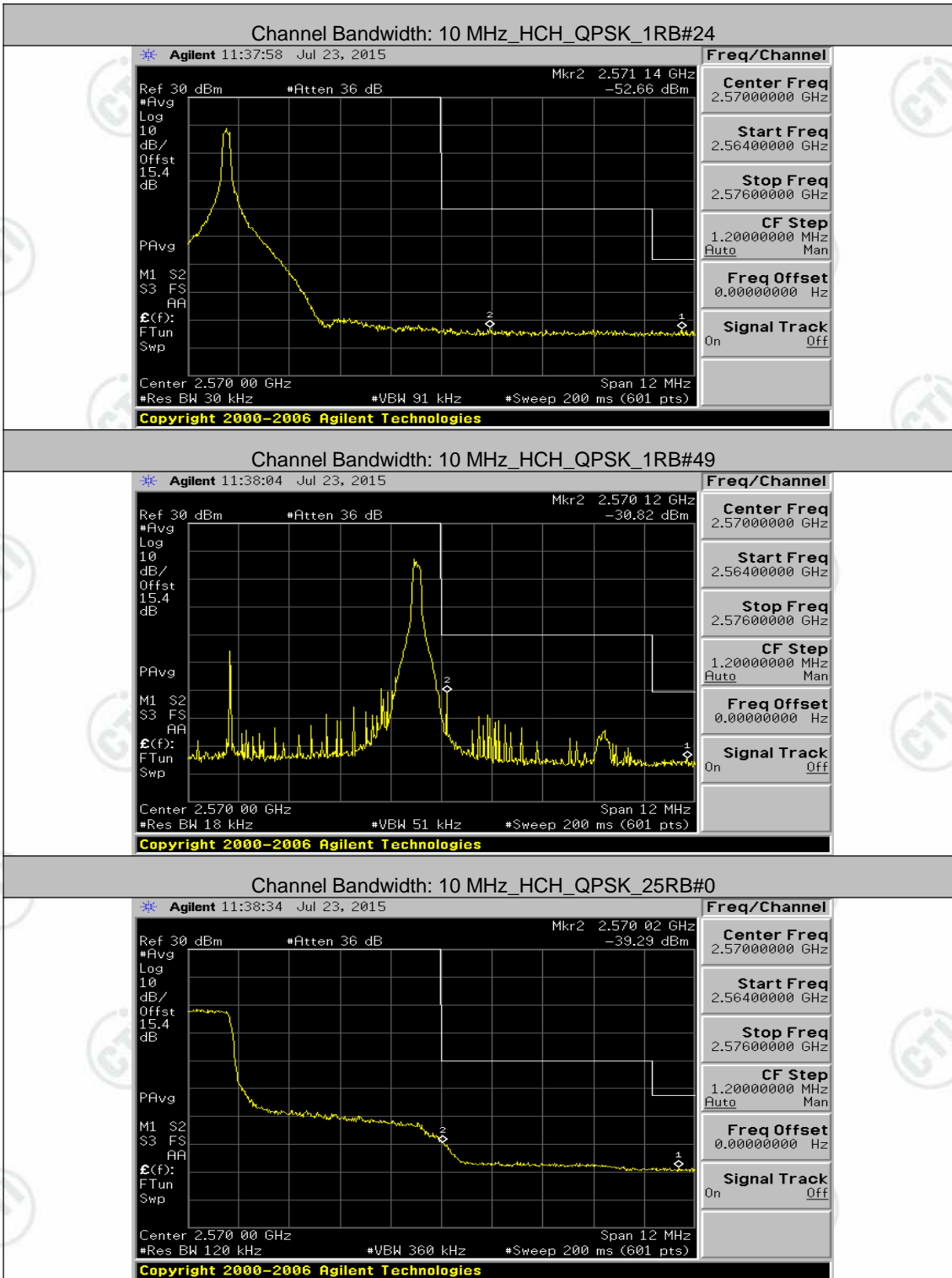

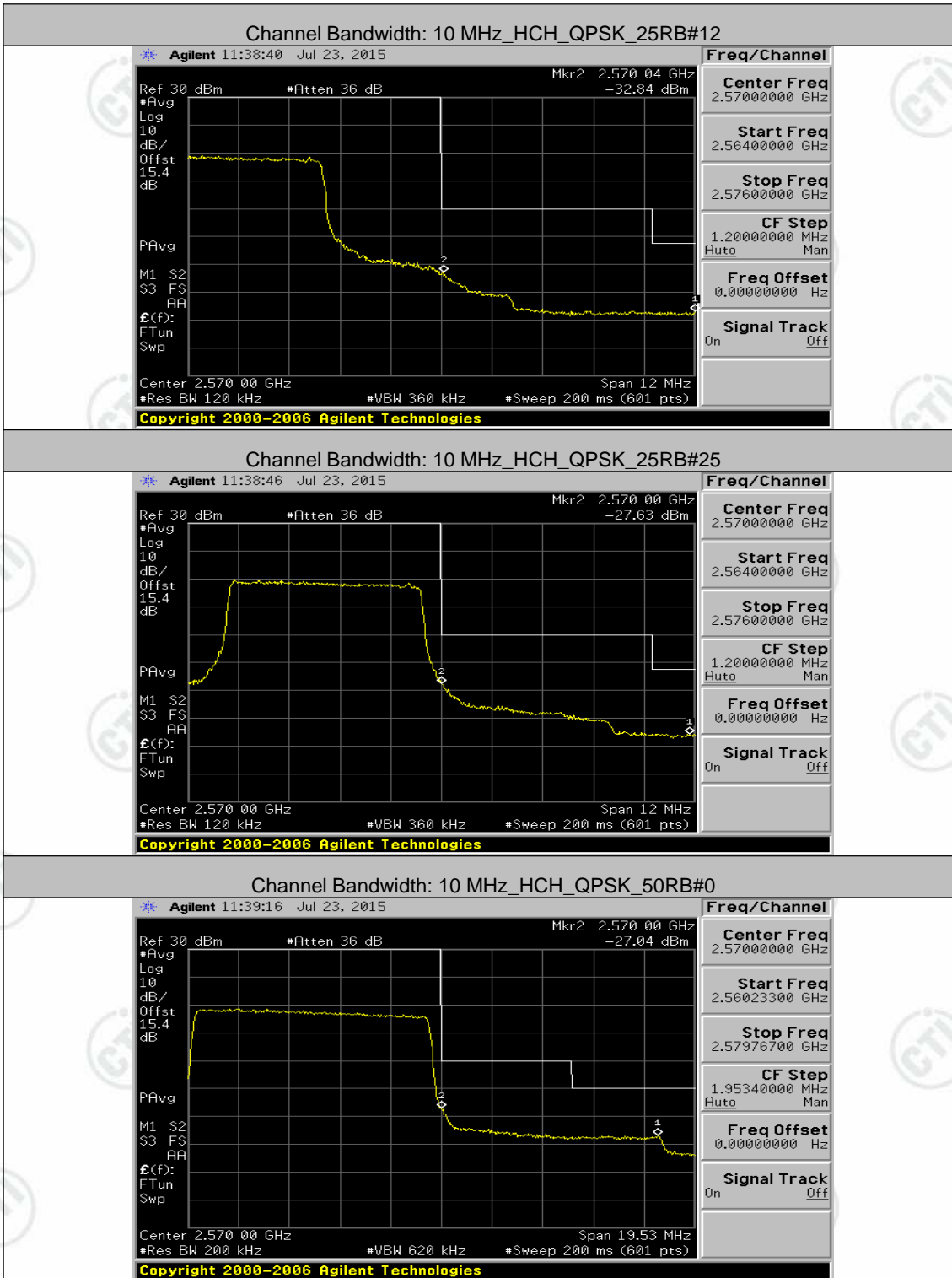

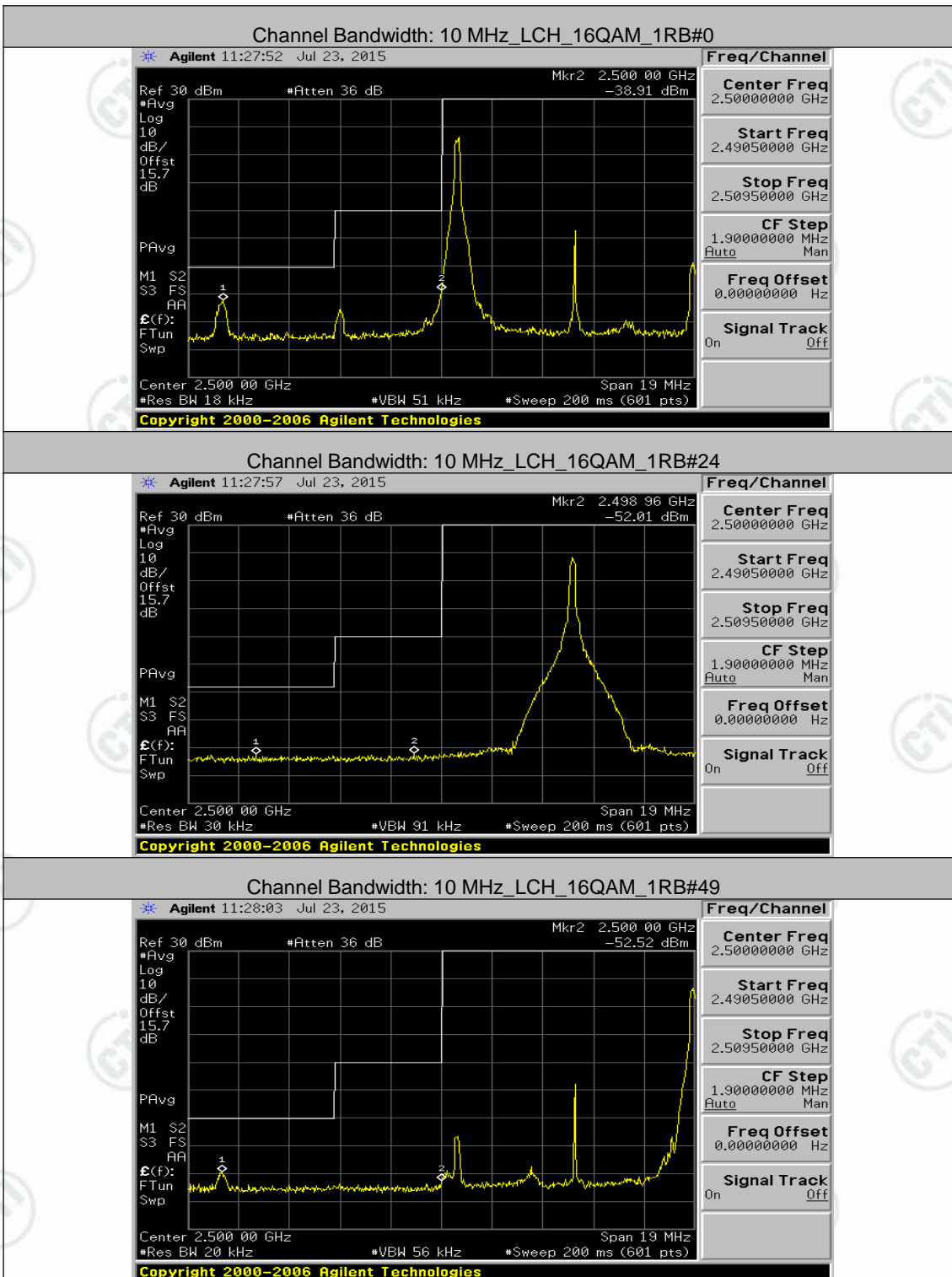

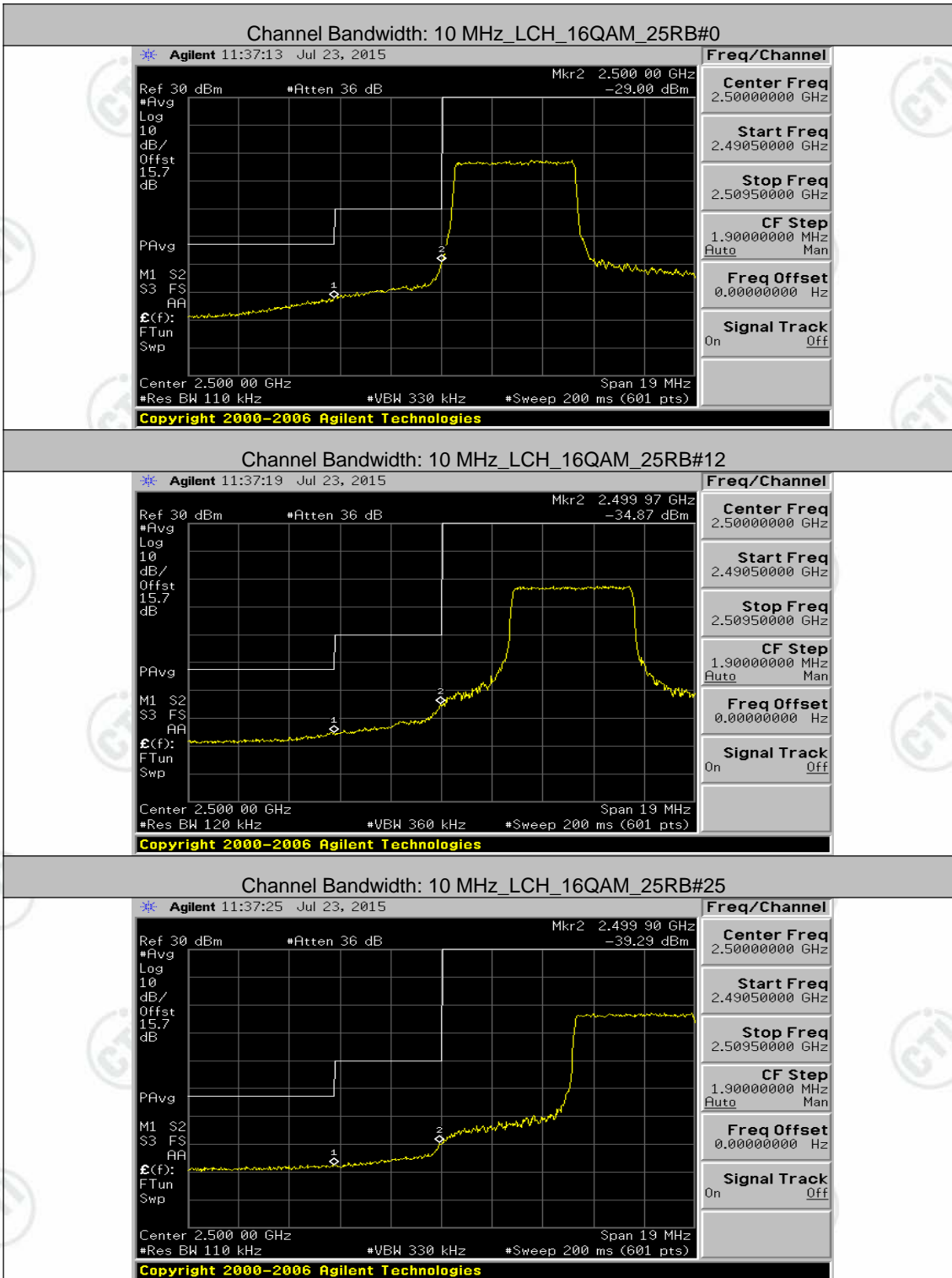

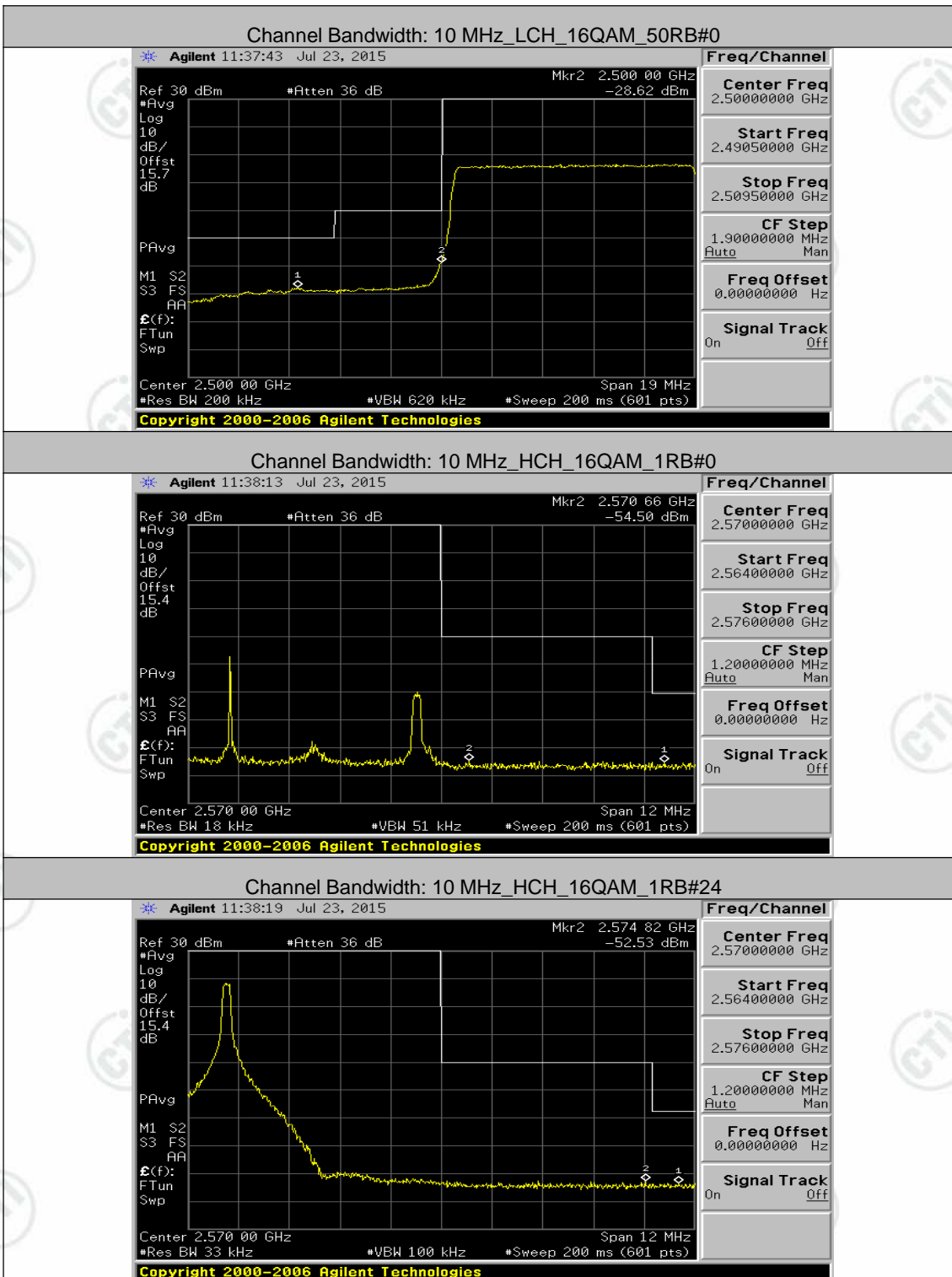

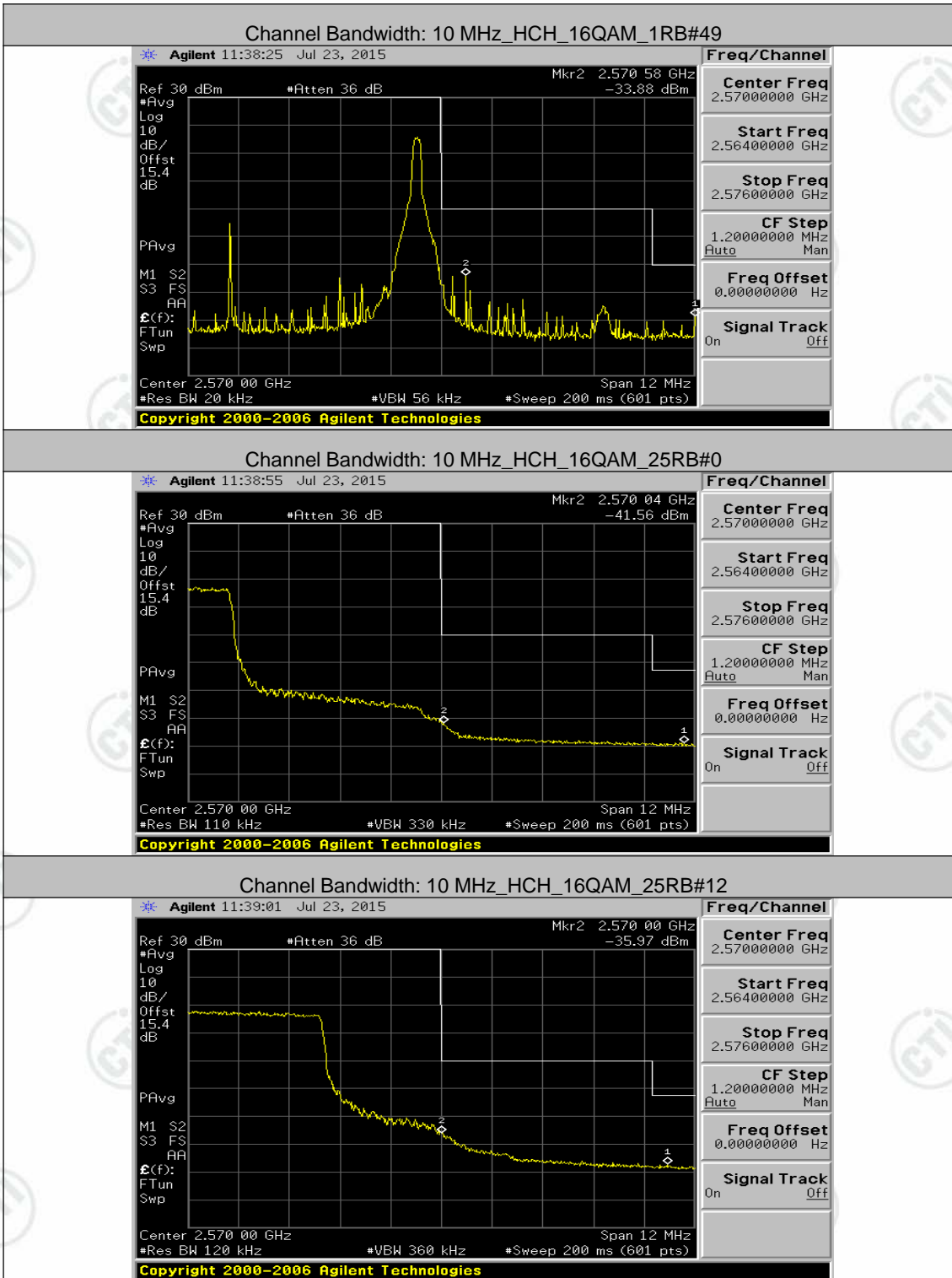

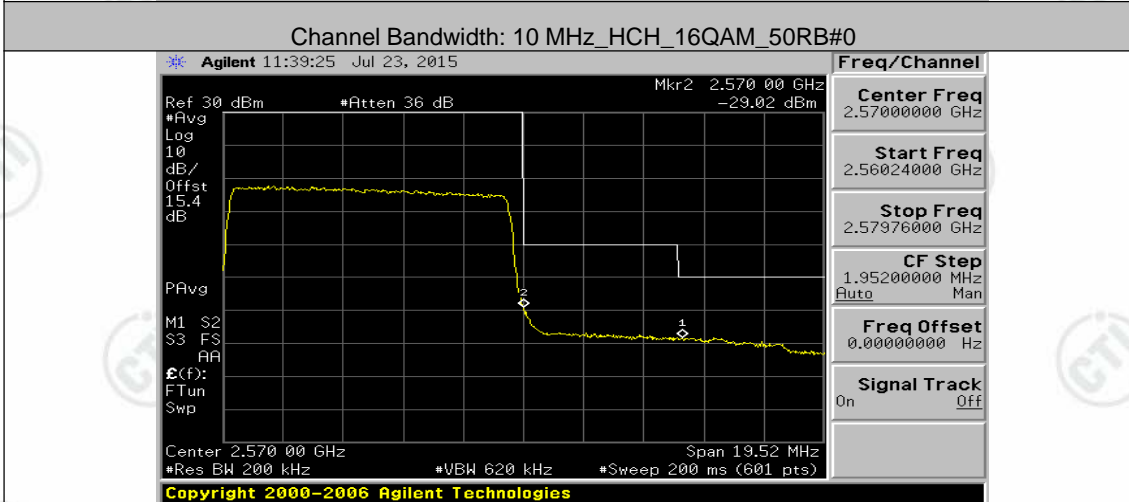
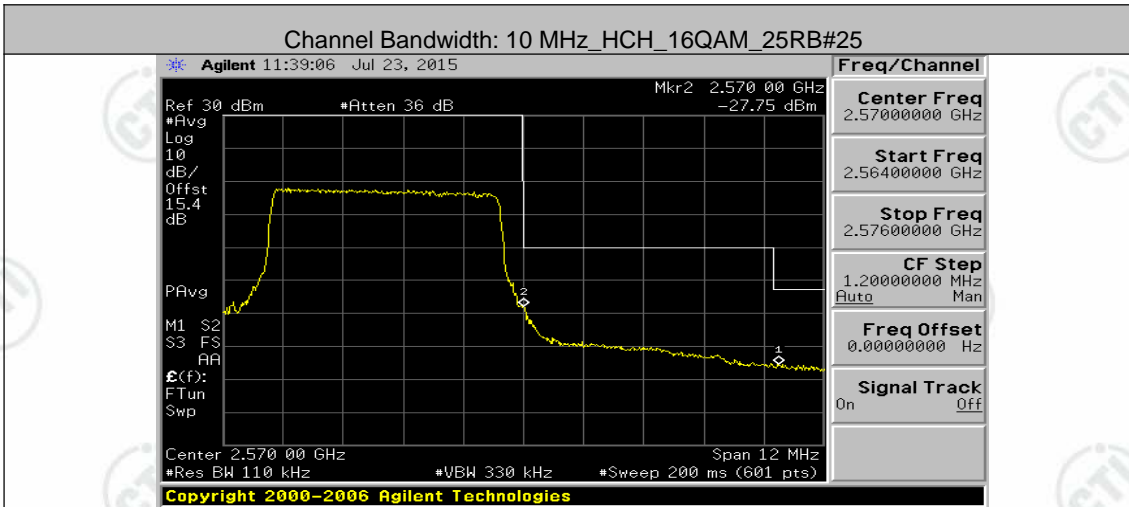

Channel Bandwidth: 15 MHz

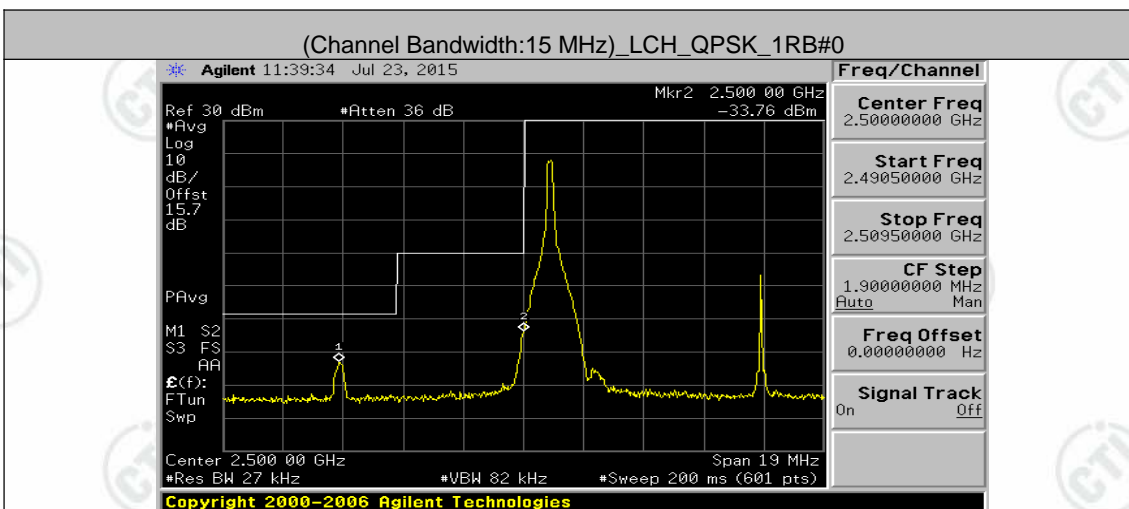

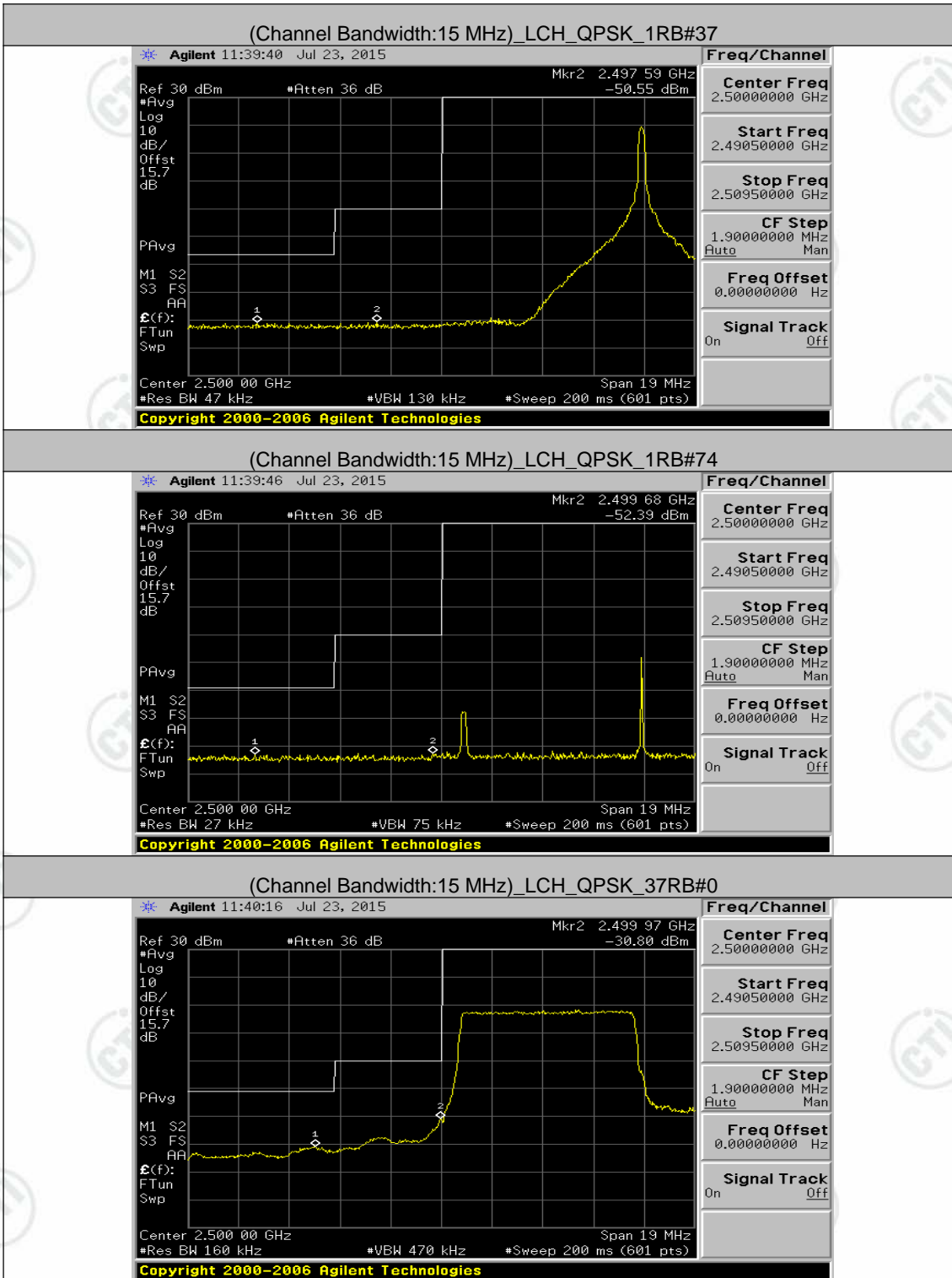

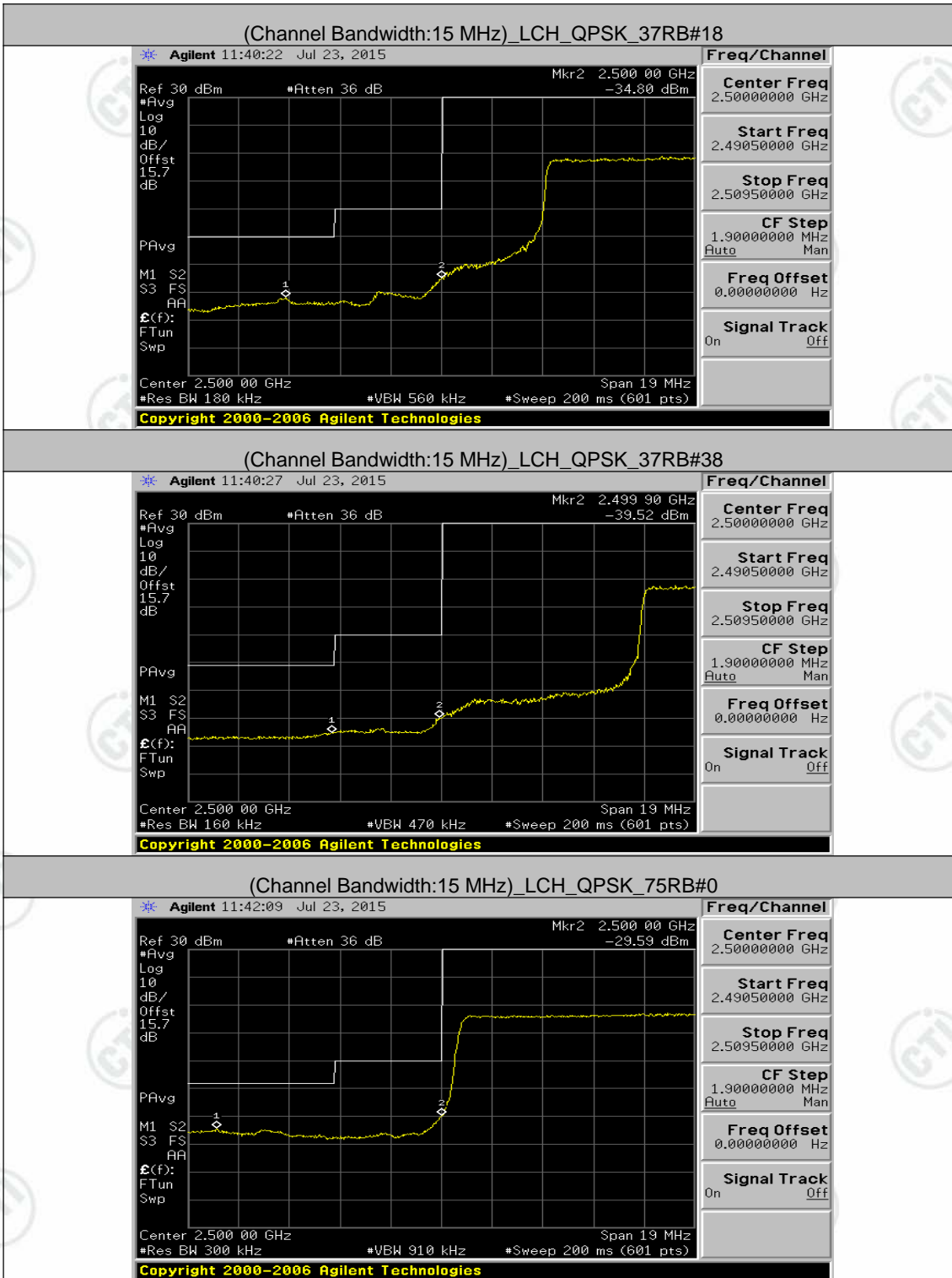

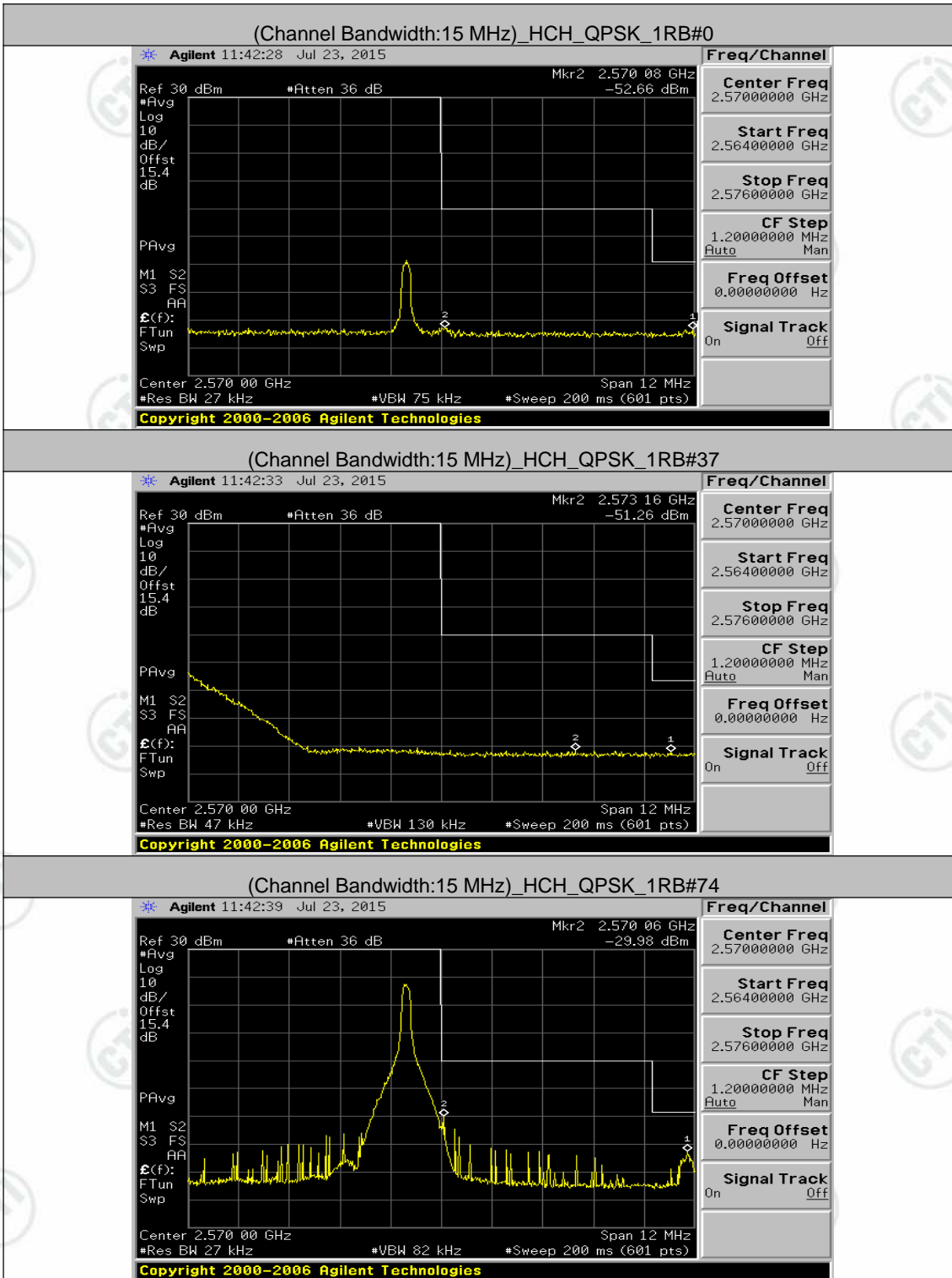

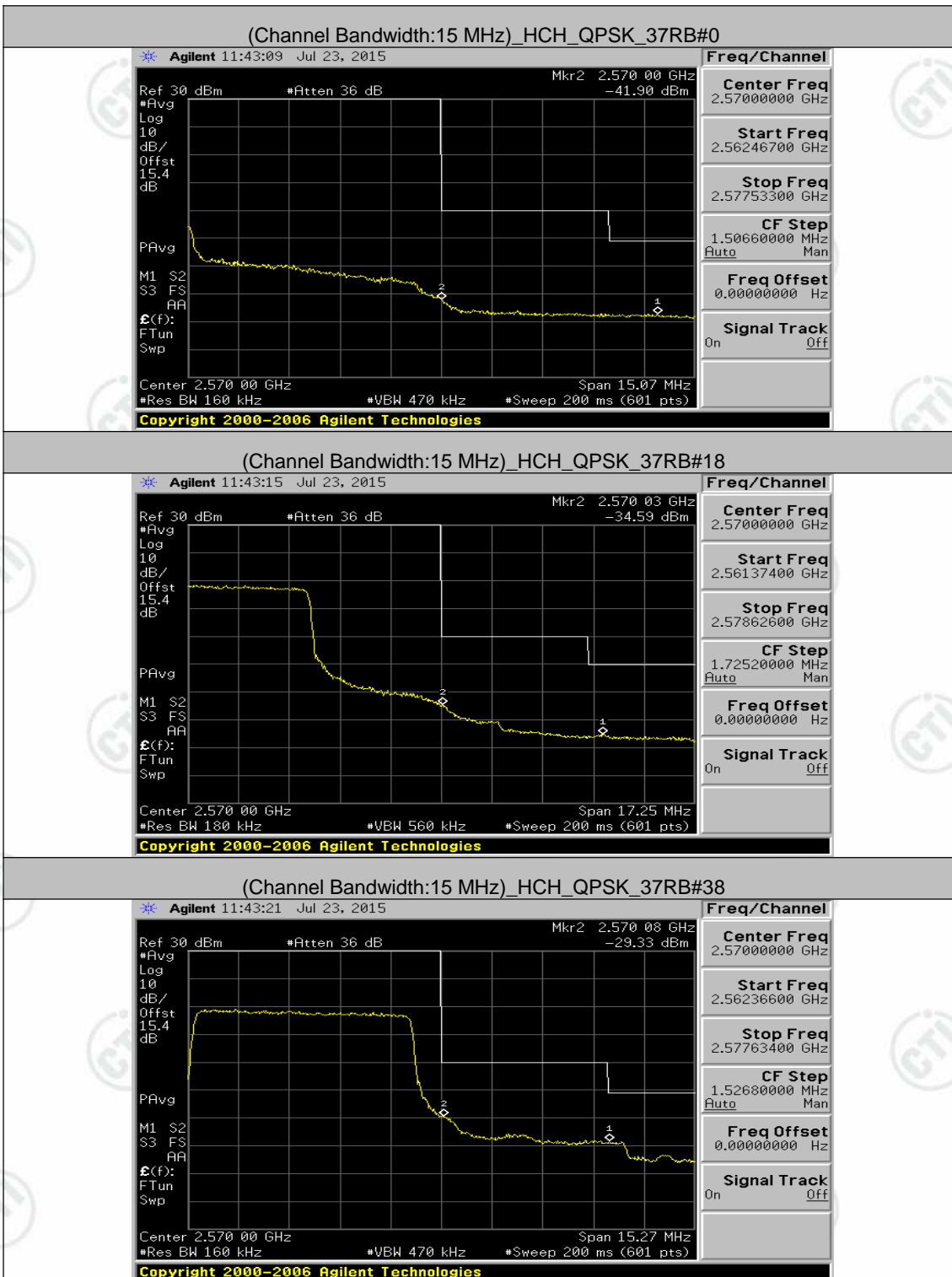

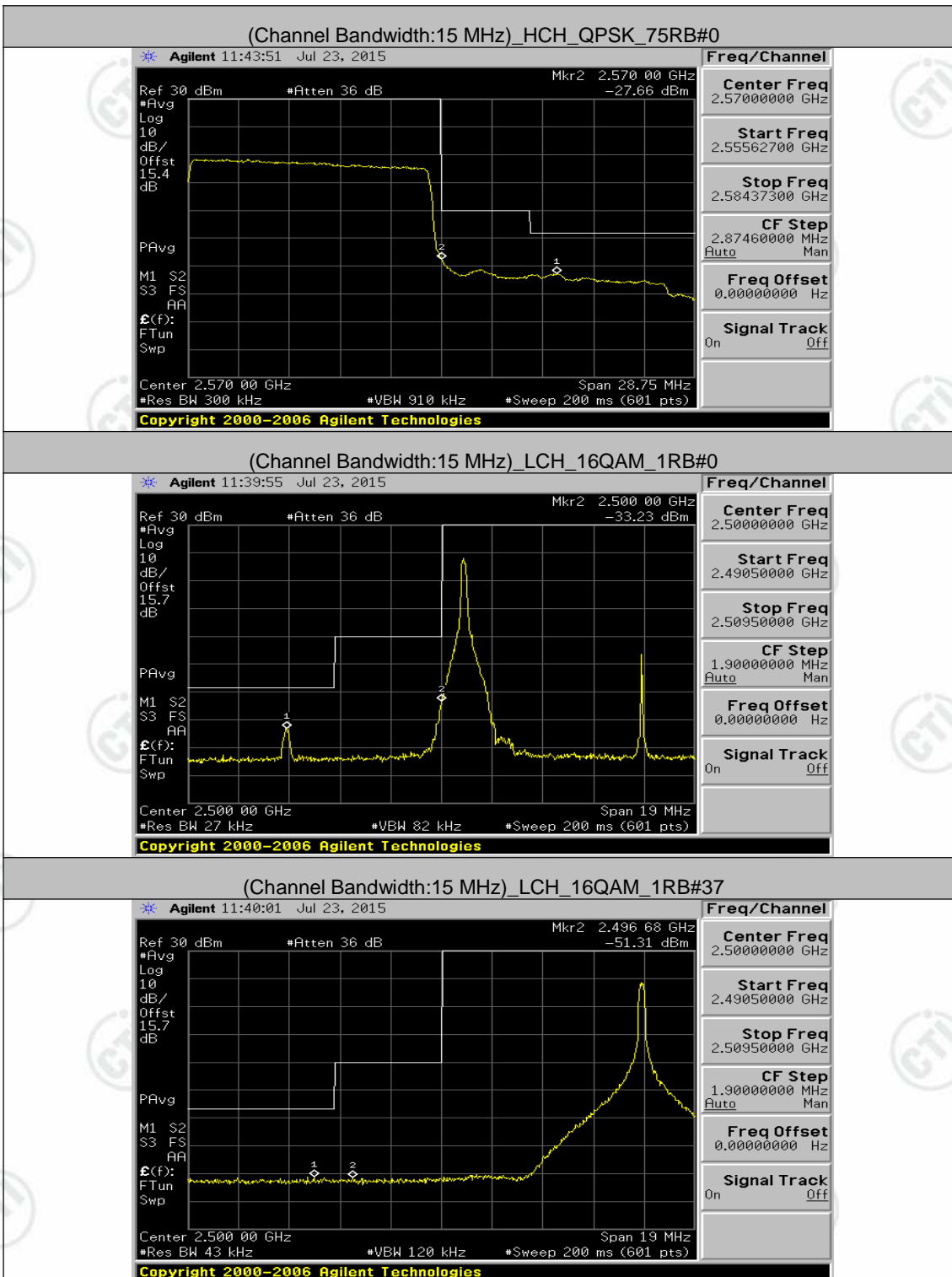

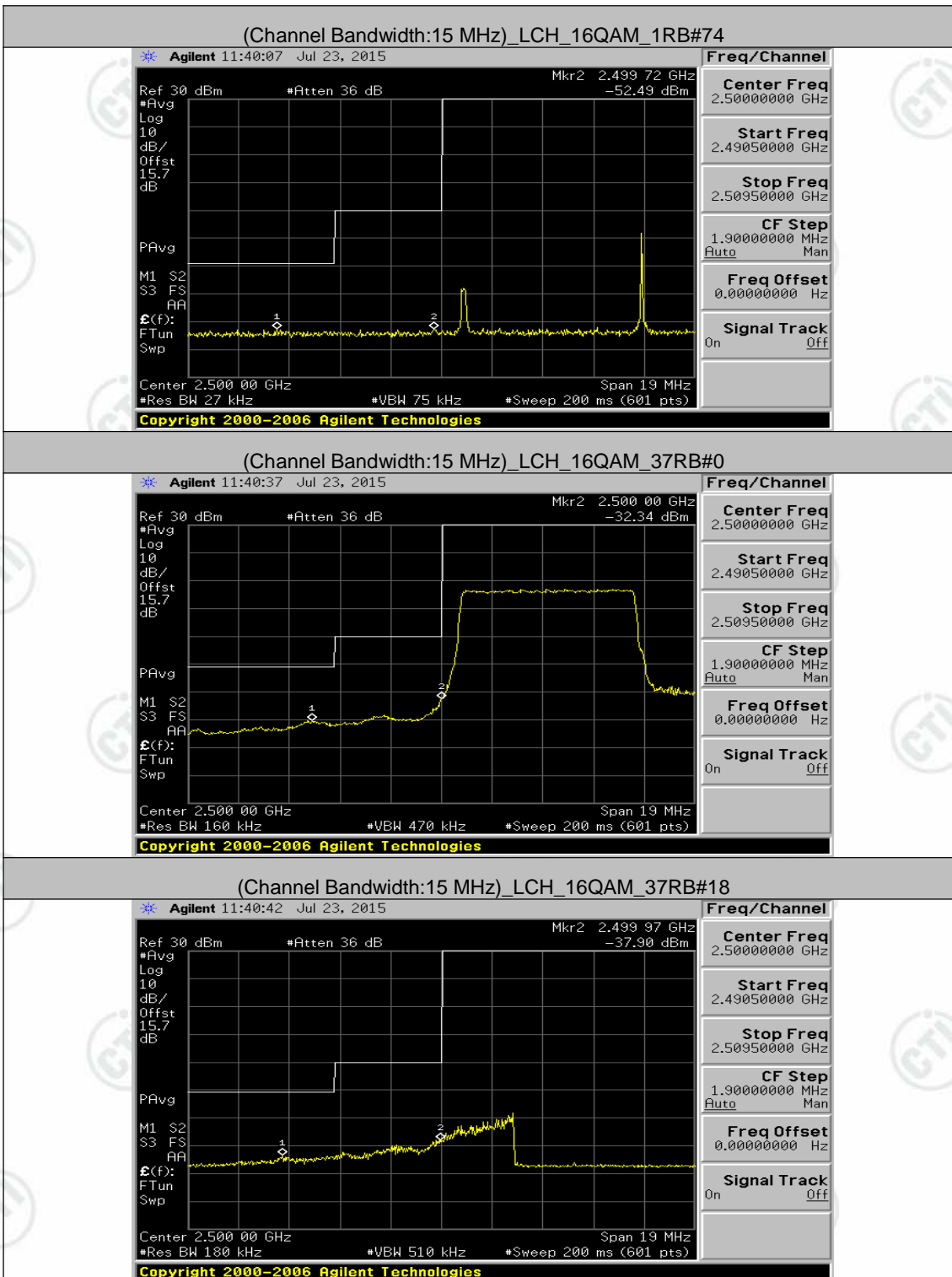

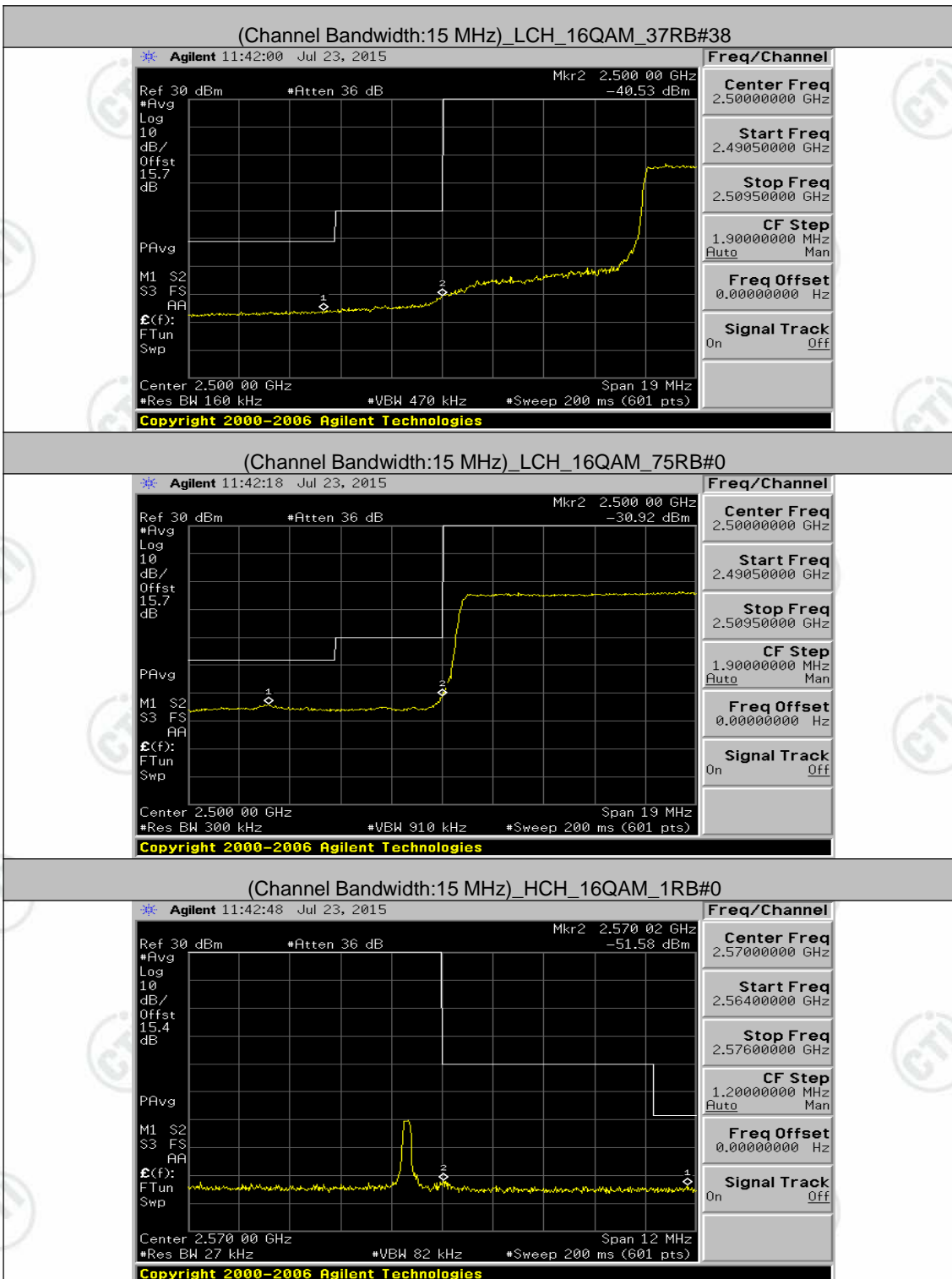

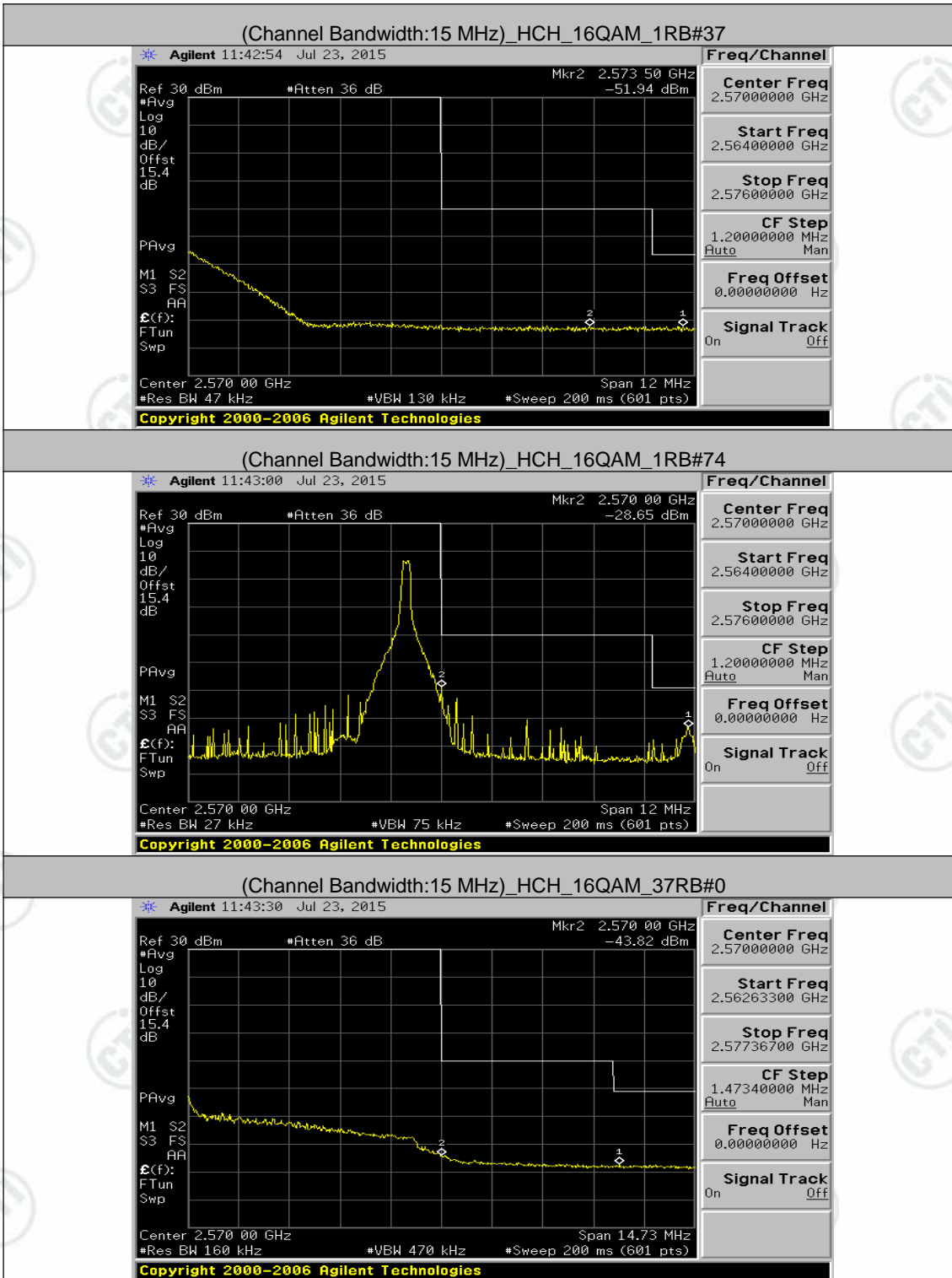

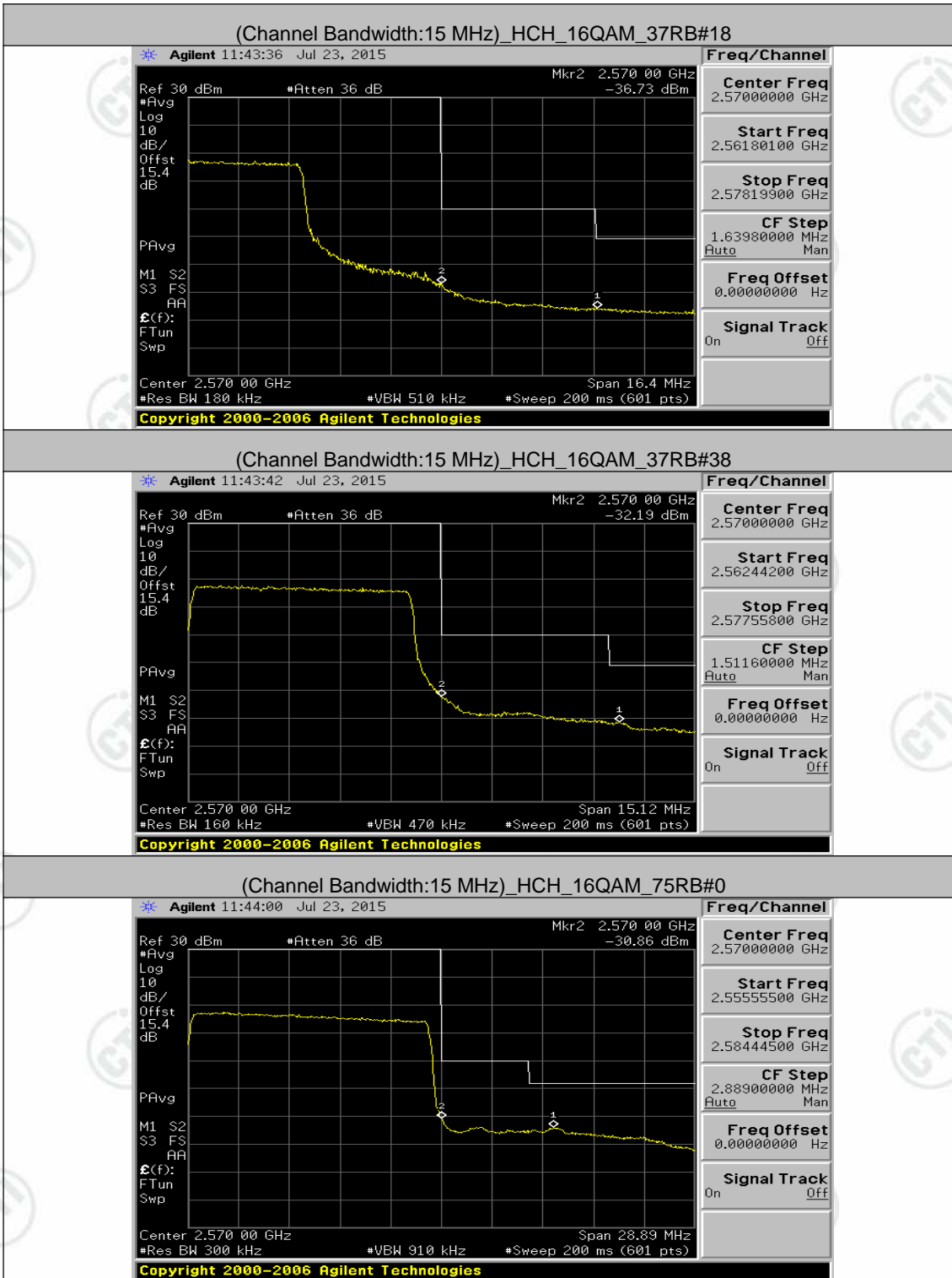

Channel Bandwidth: 20 MHz

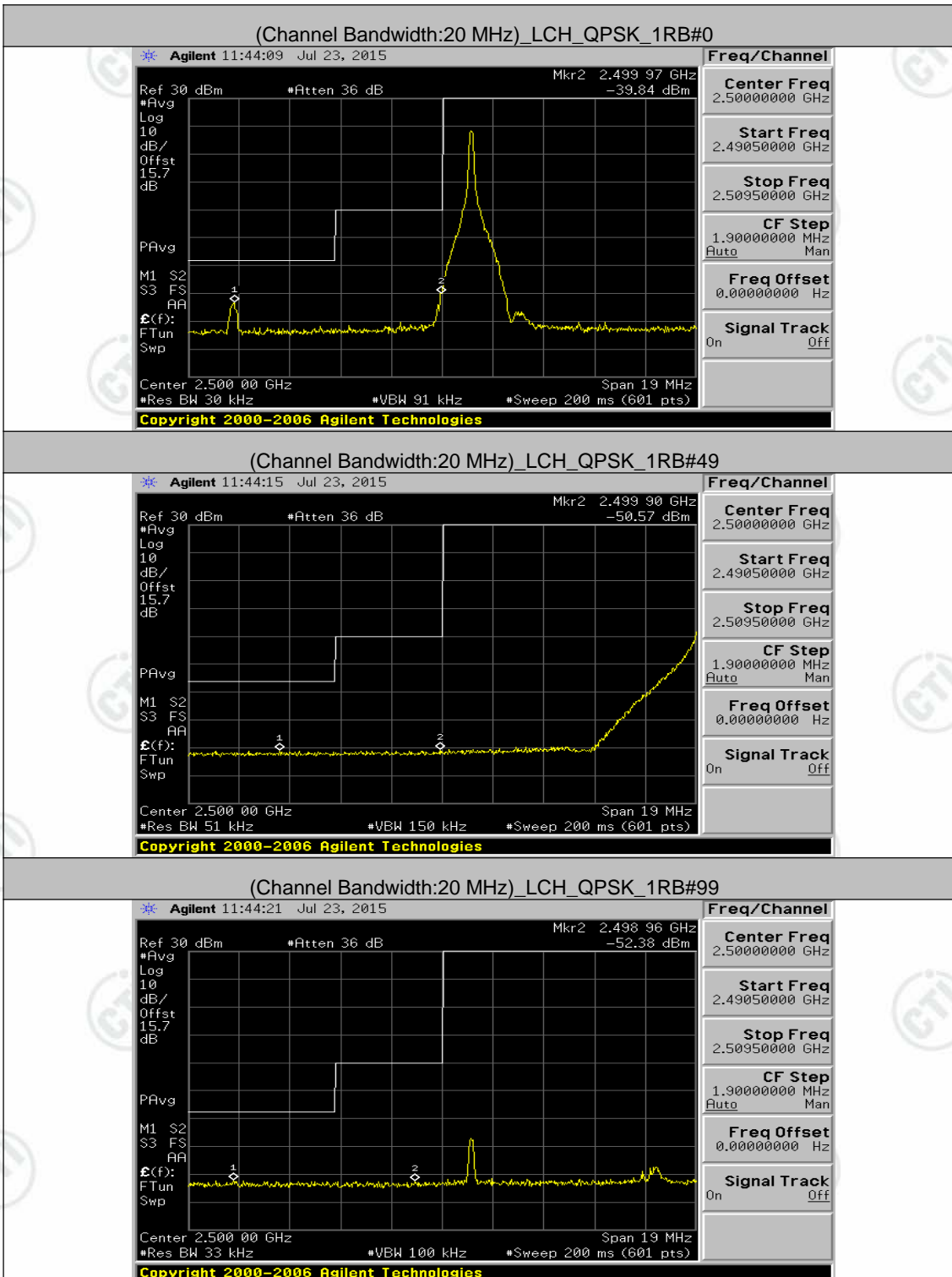

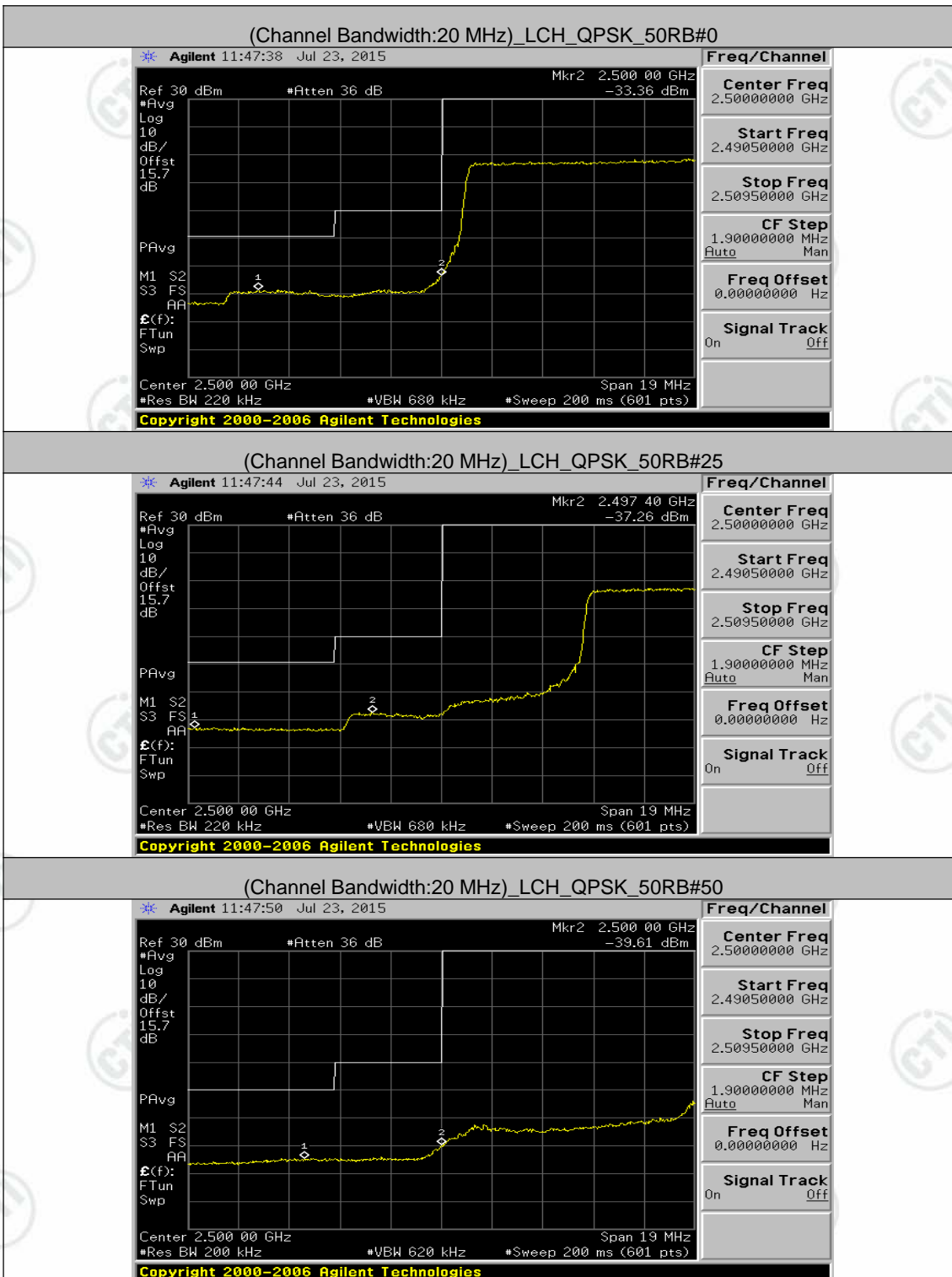

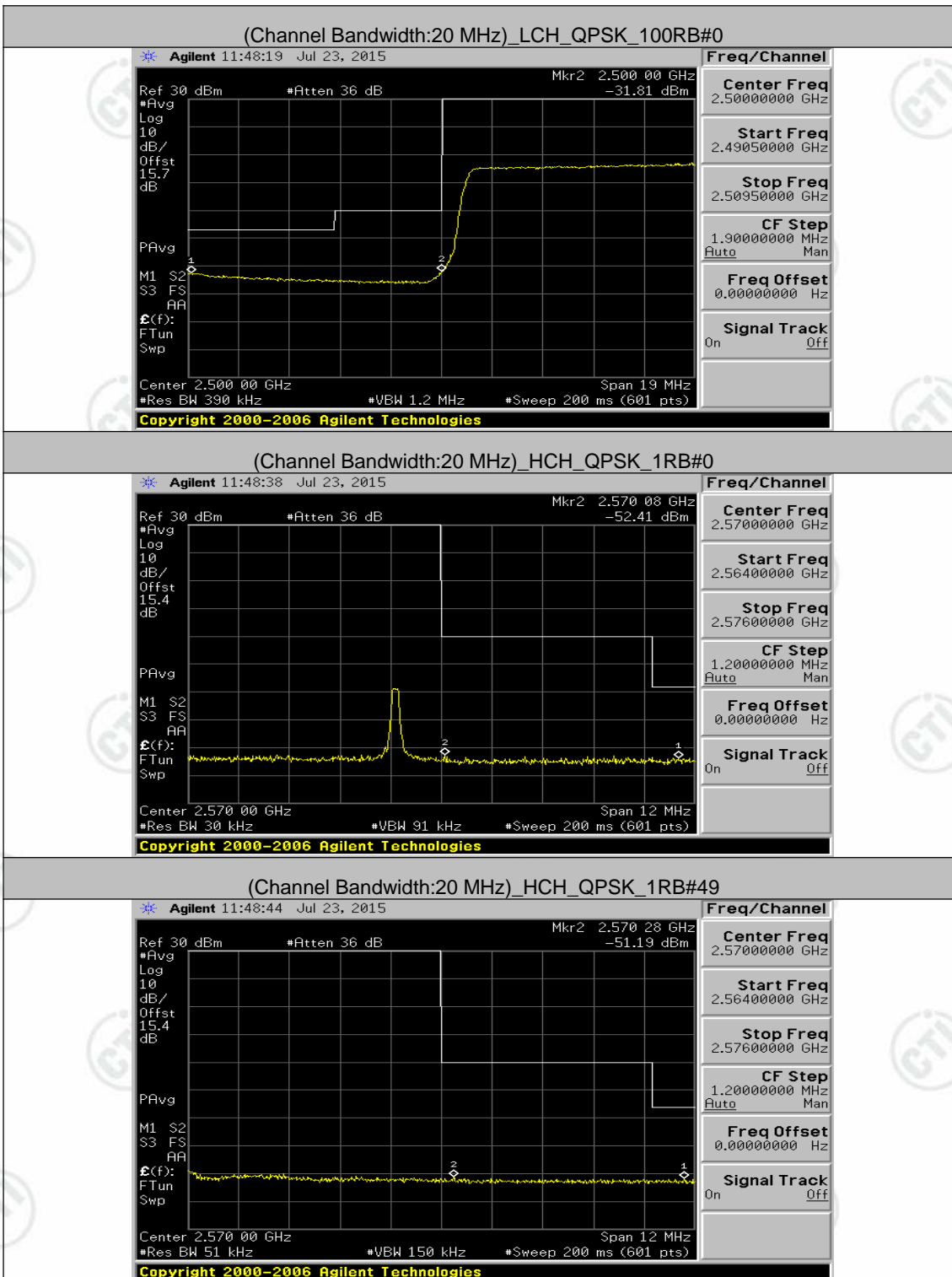

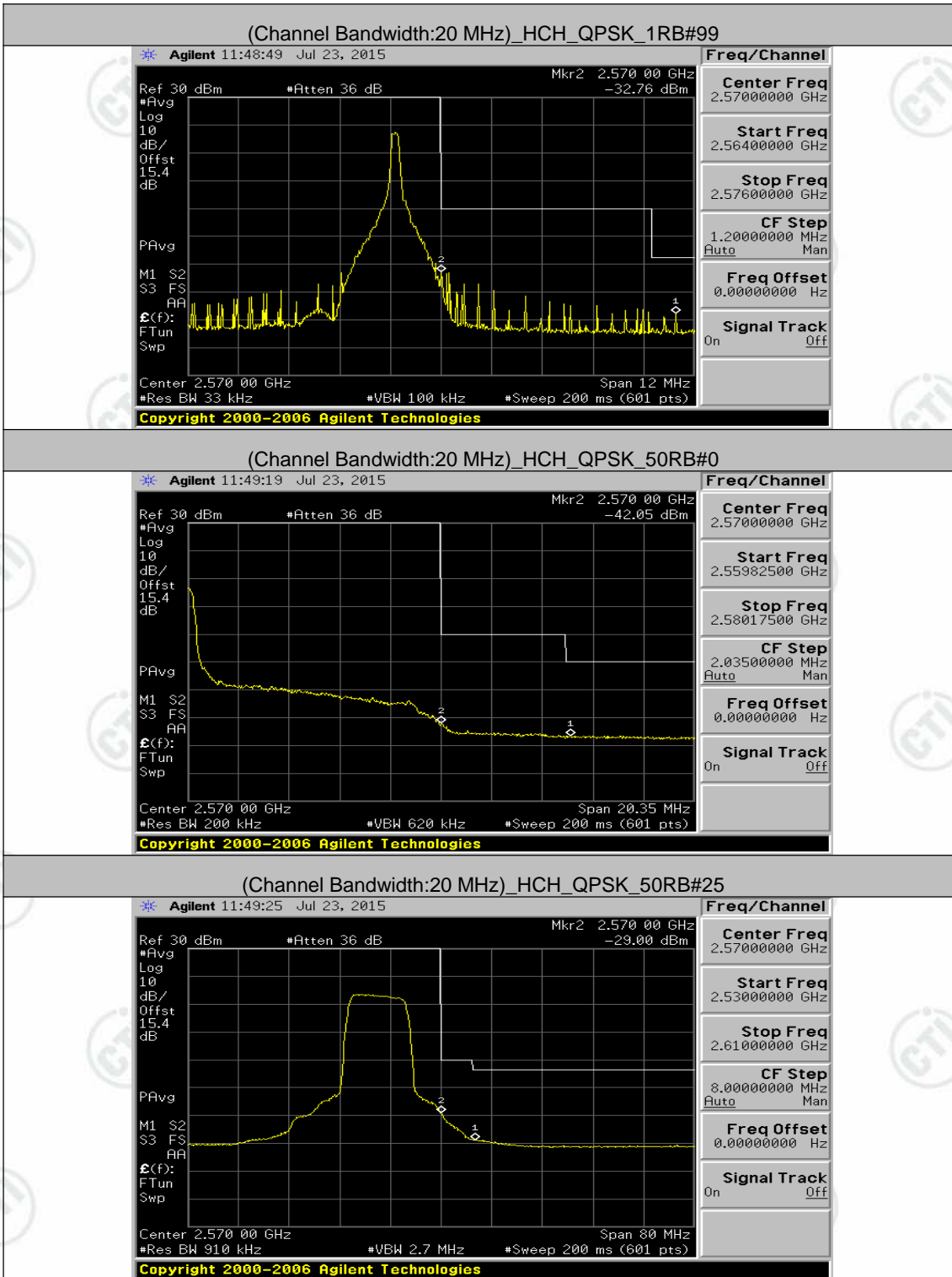

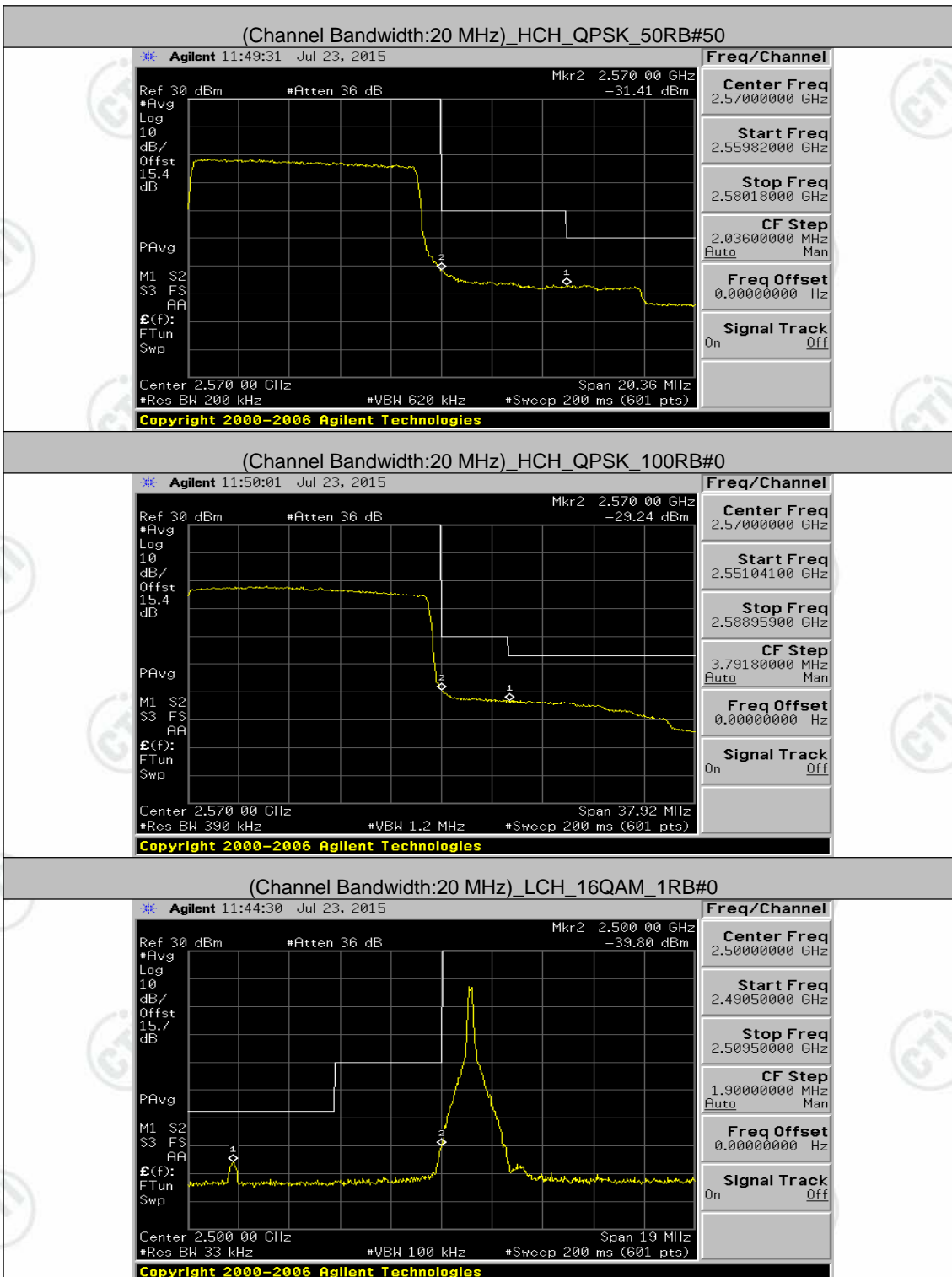

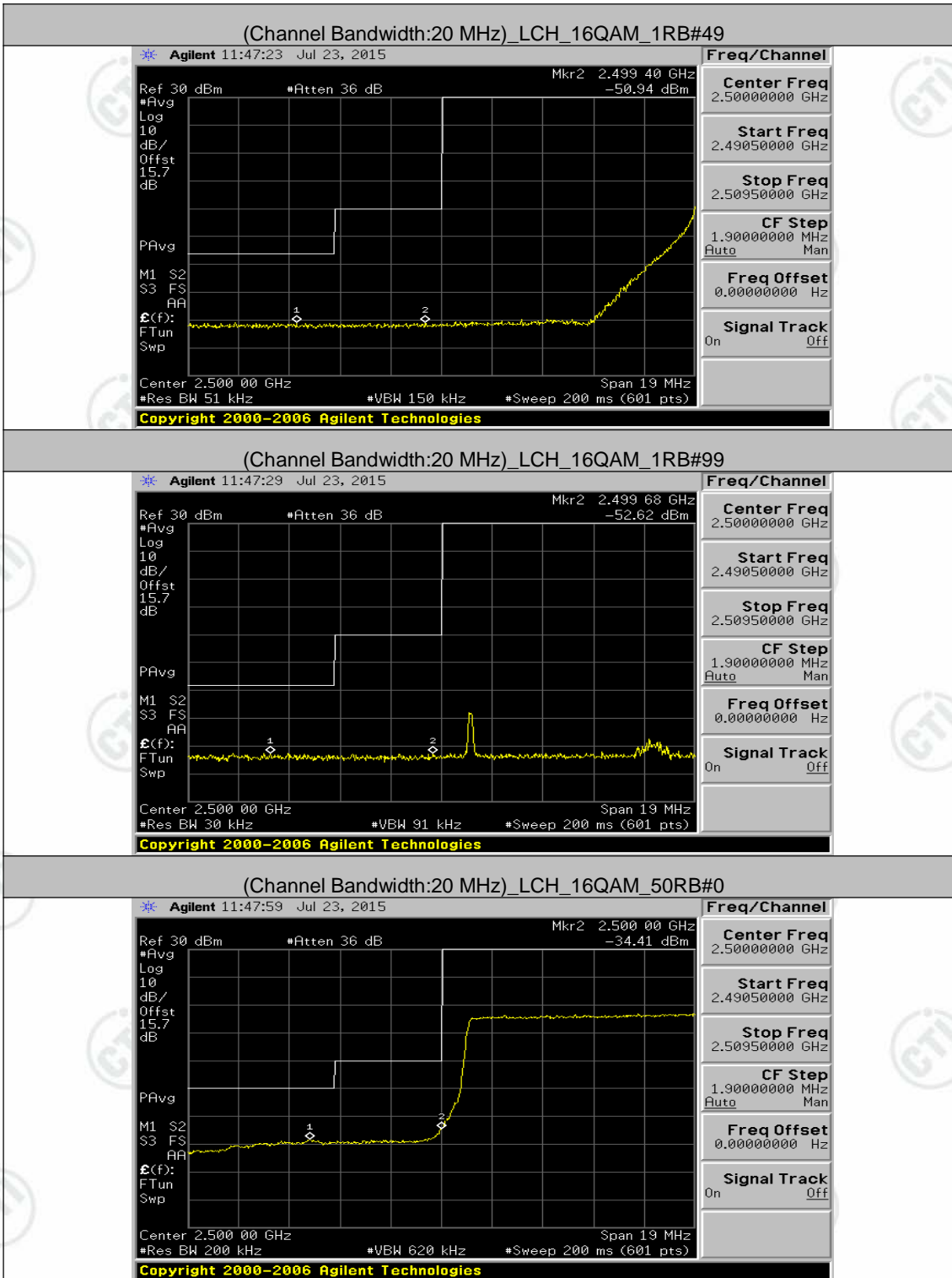

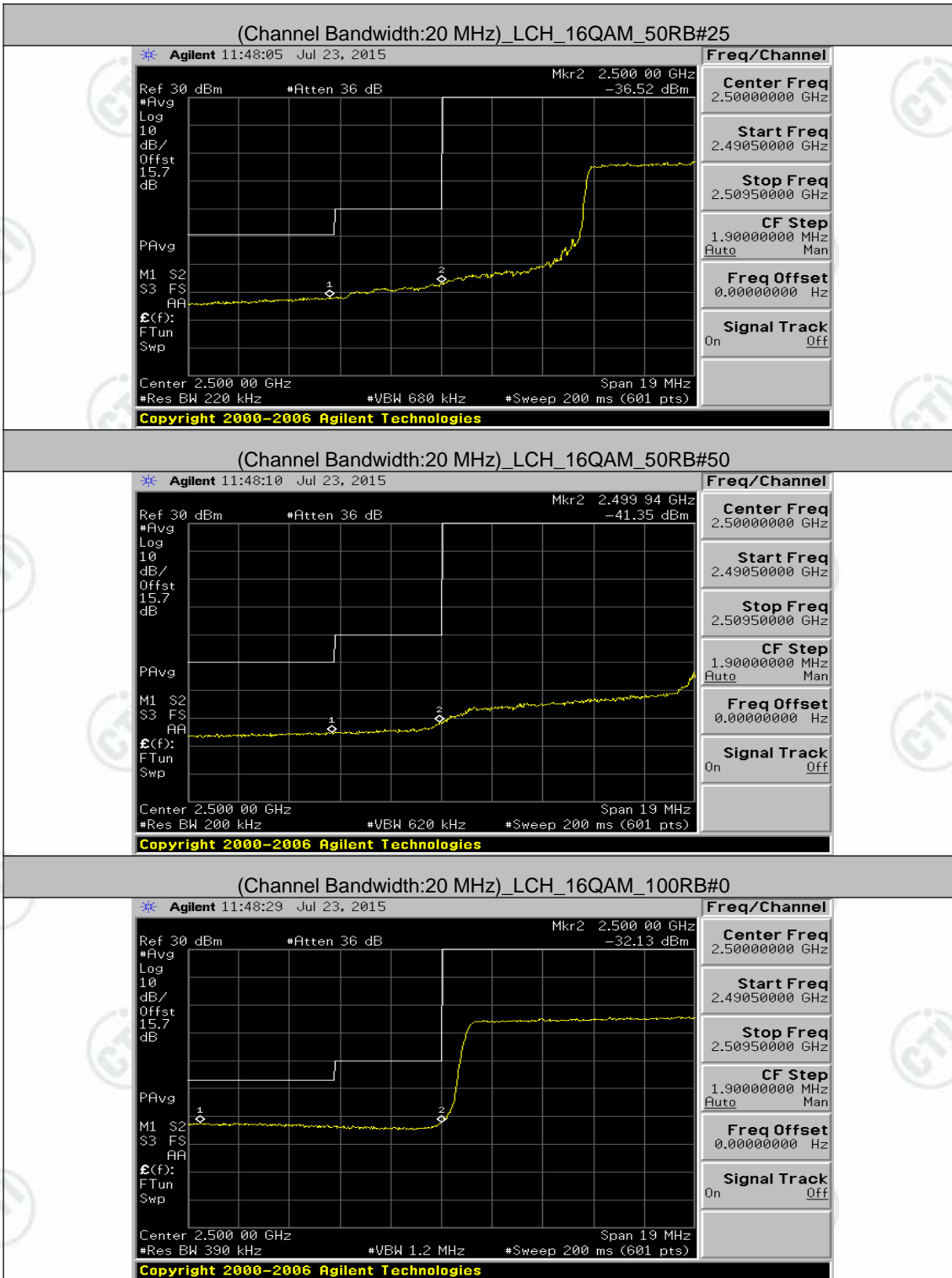

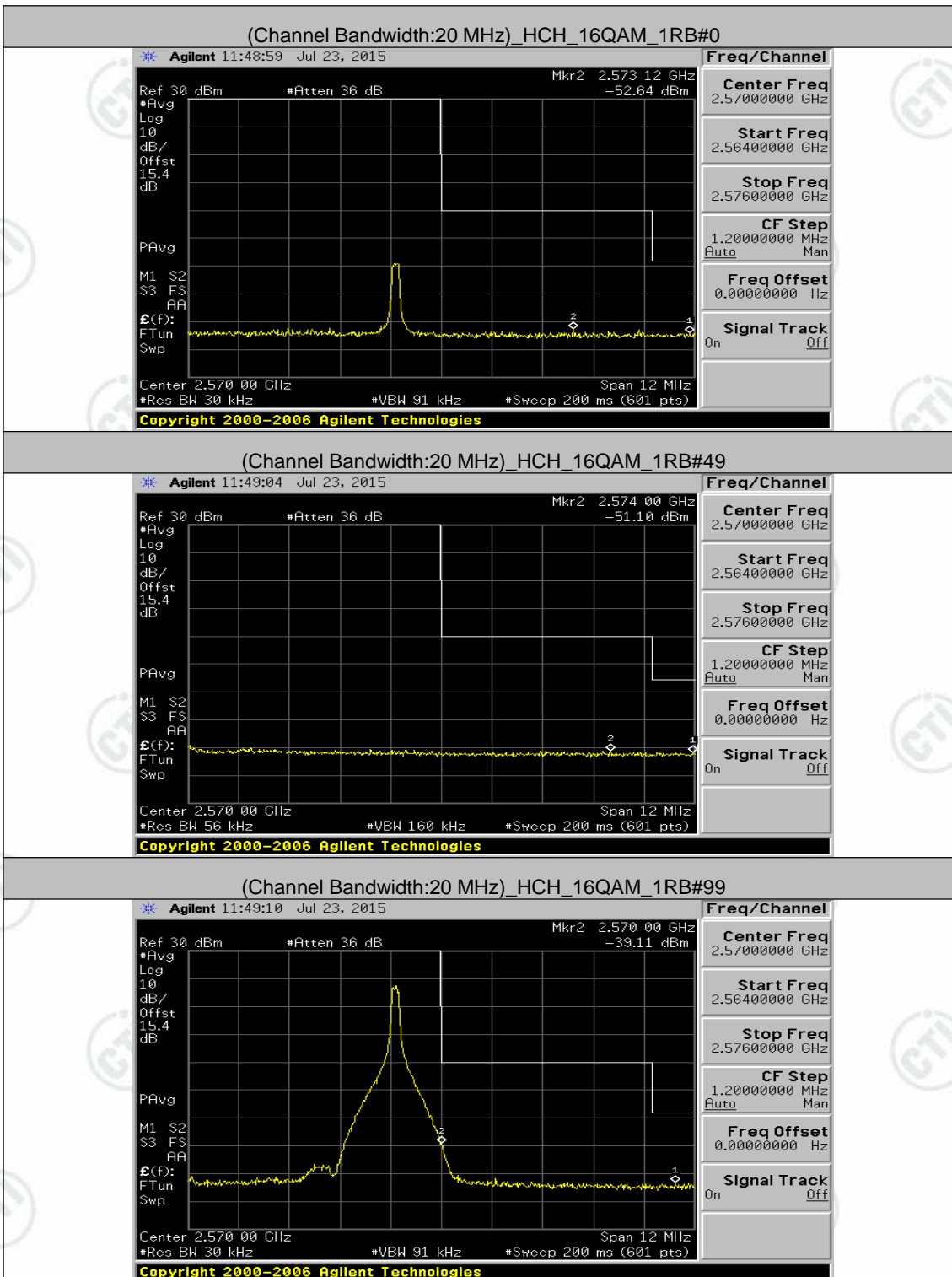

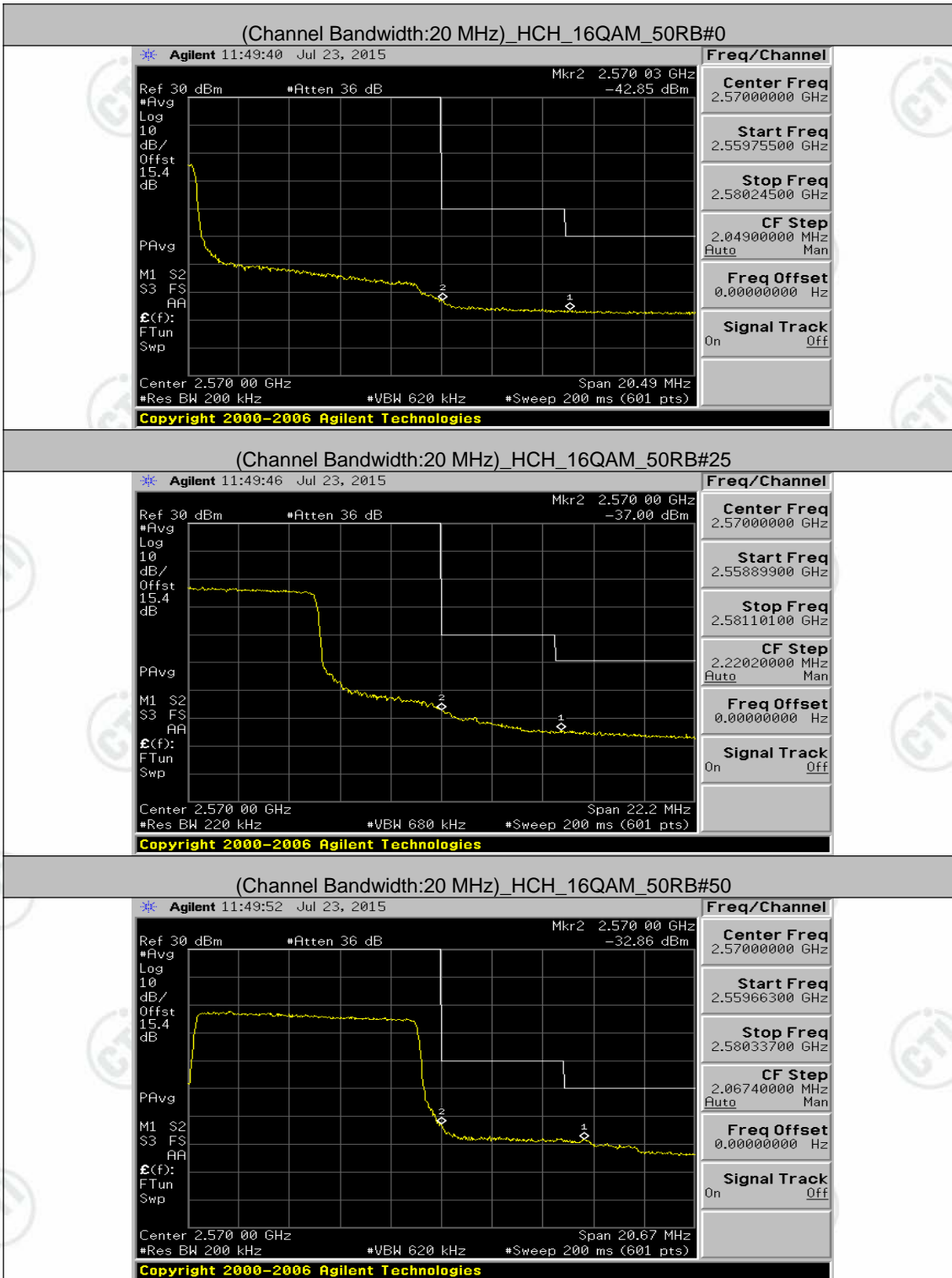

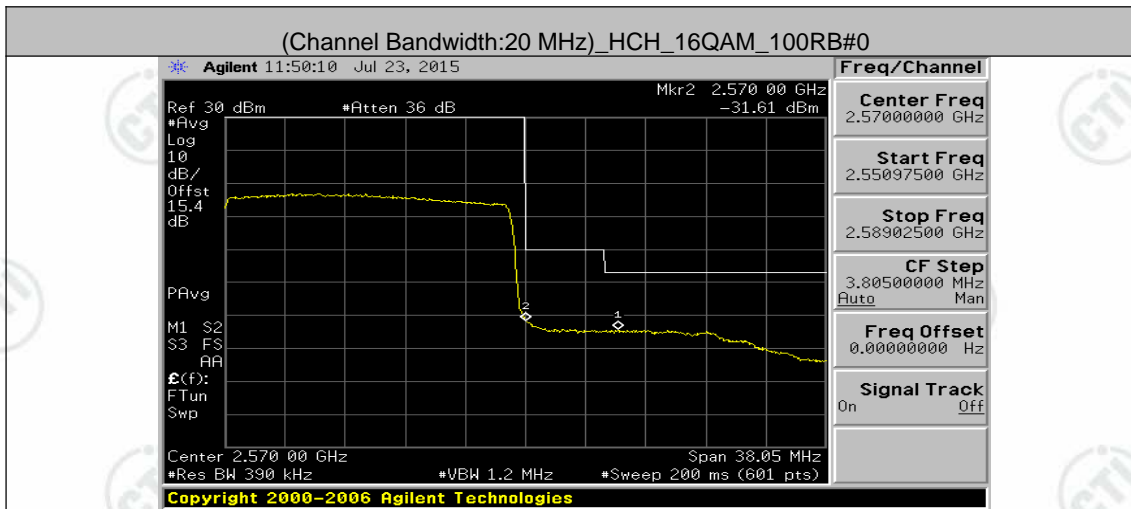

Appendix E: Conducted Spurious Emission

Test Graphs

Channel Bandwidth: 5 MHz

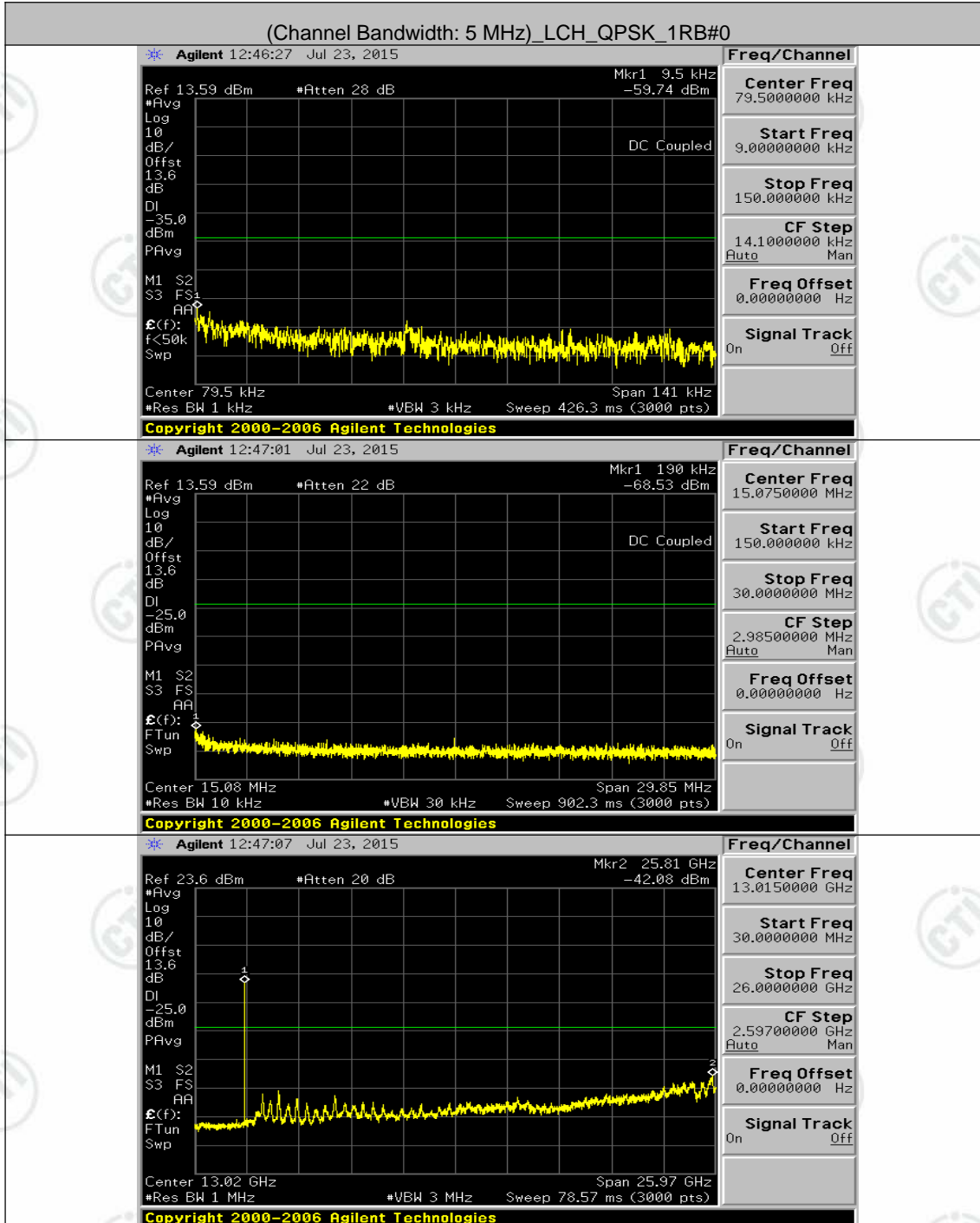

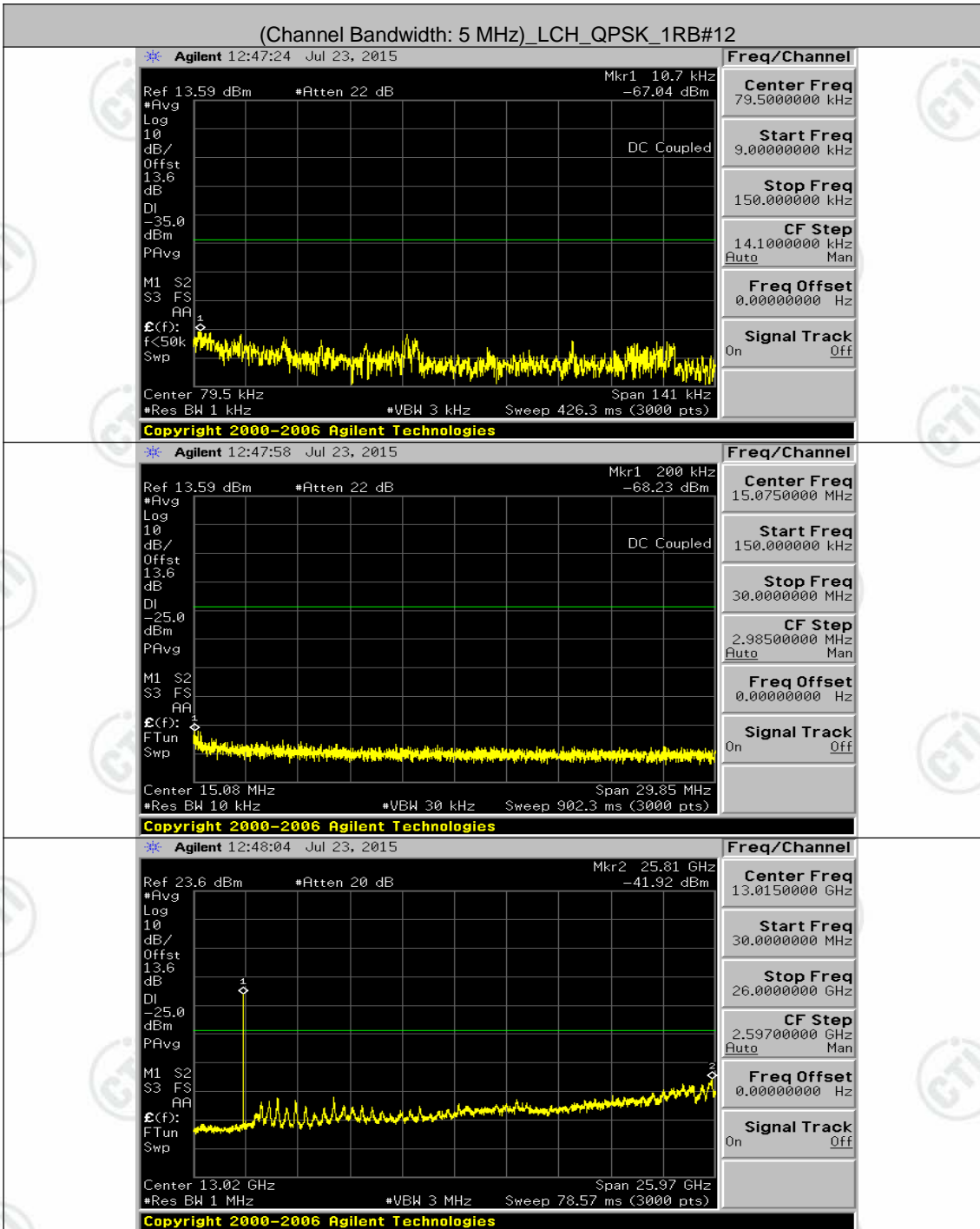

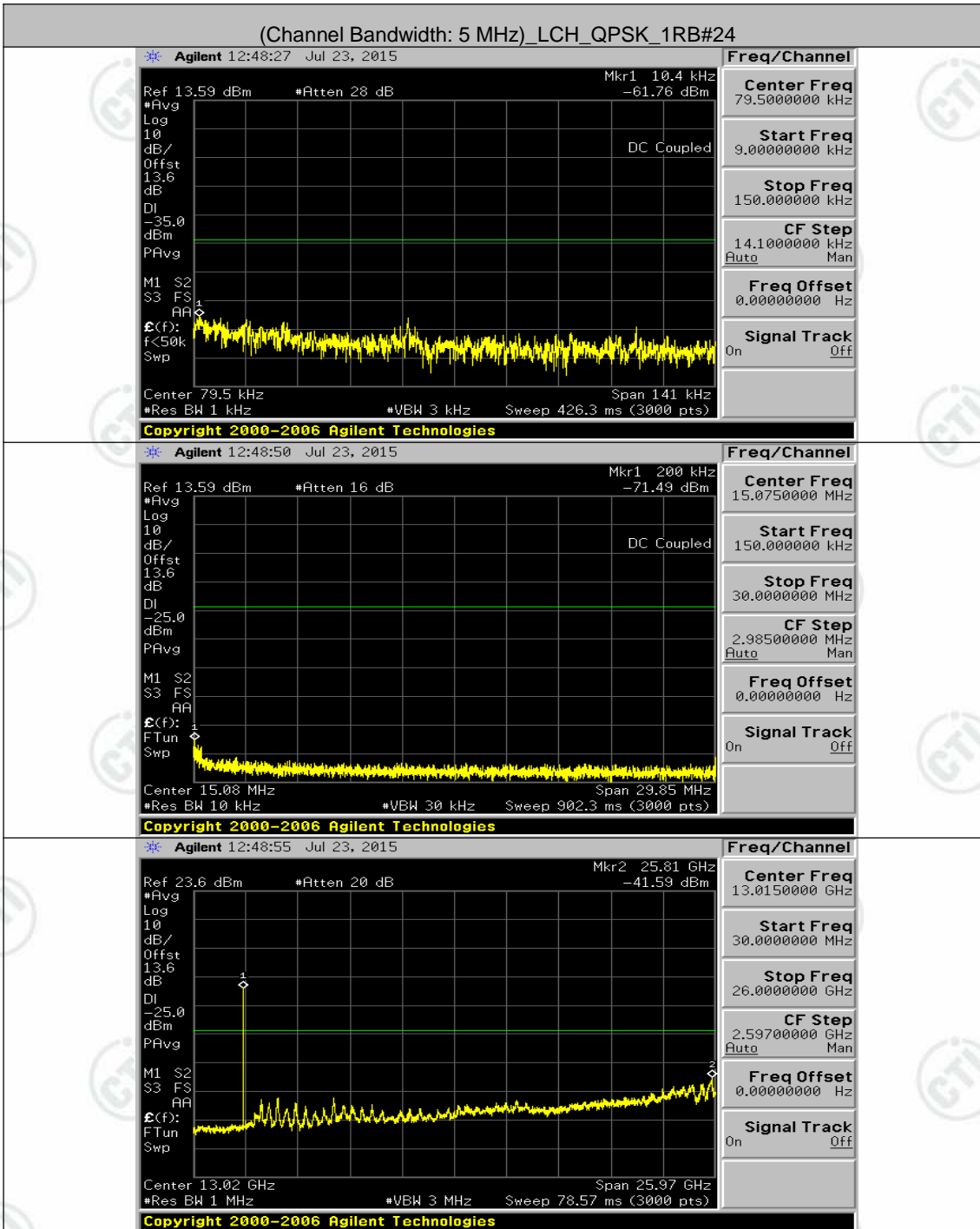

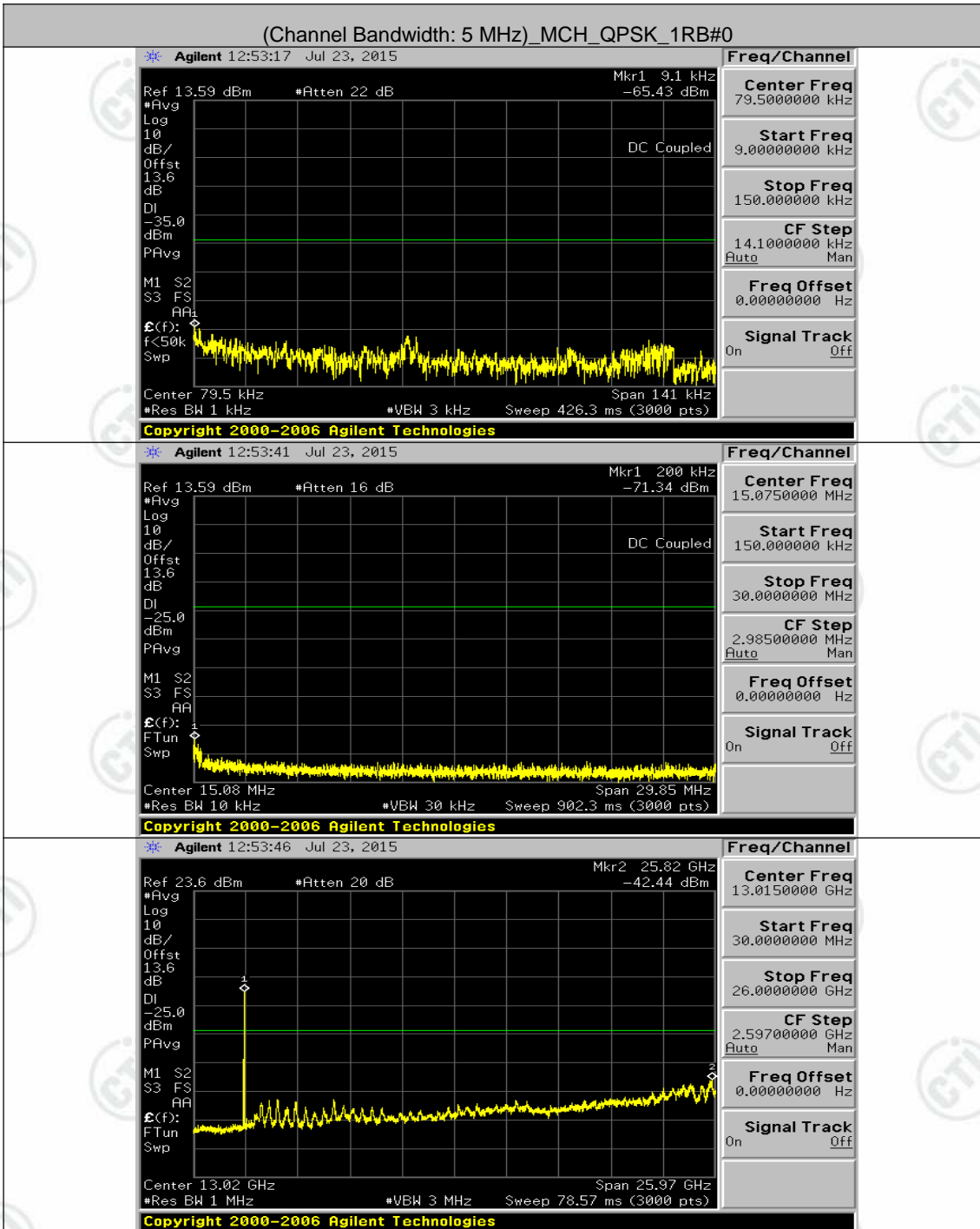

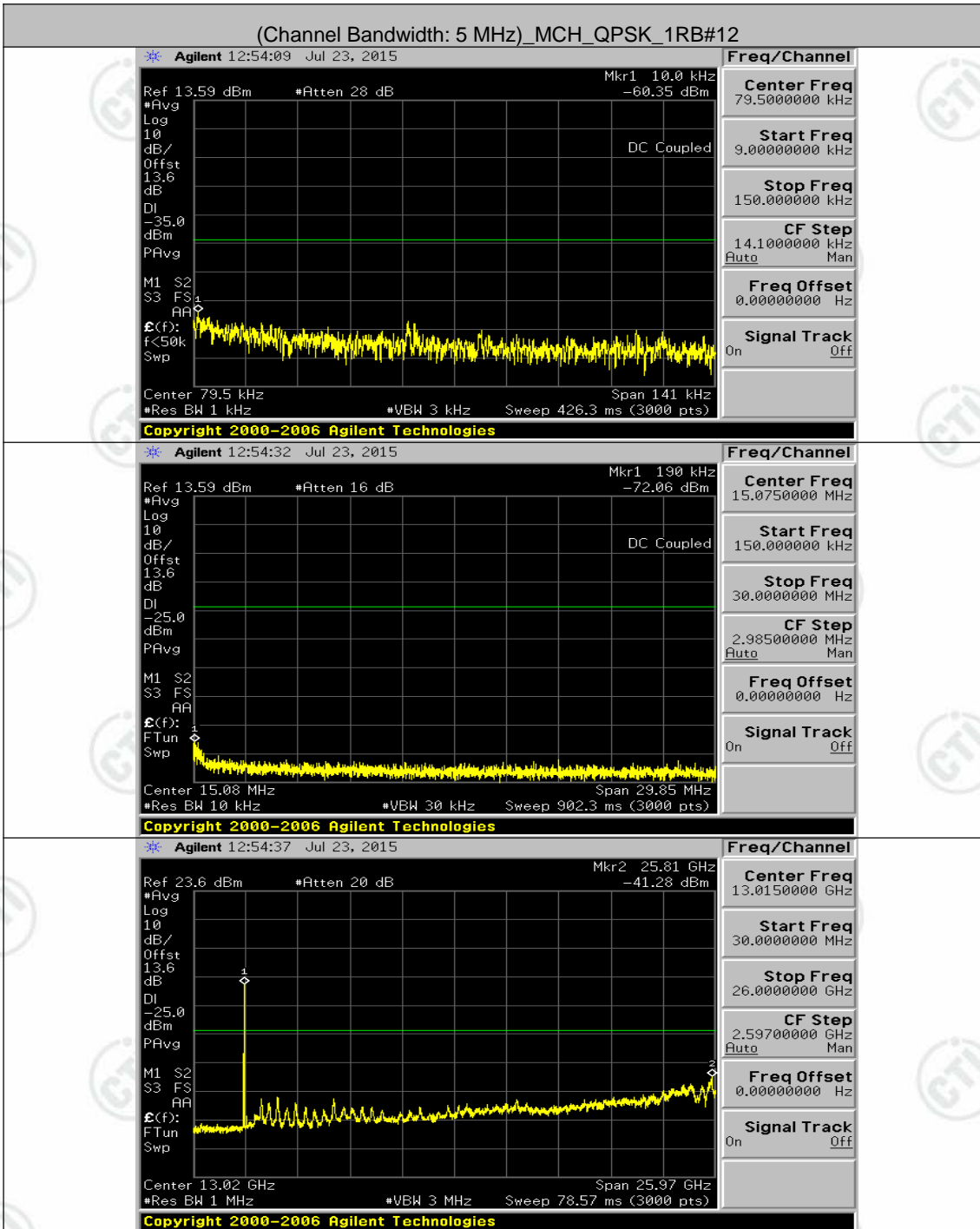

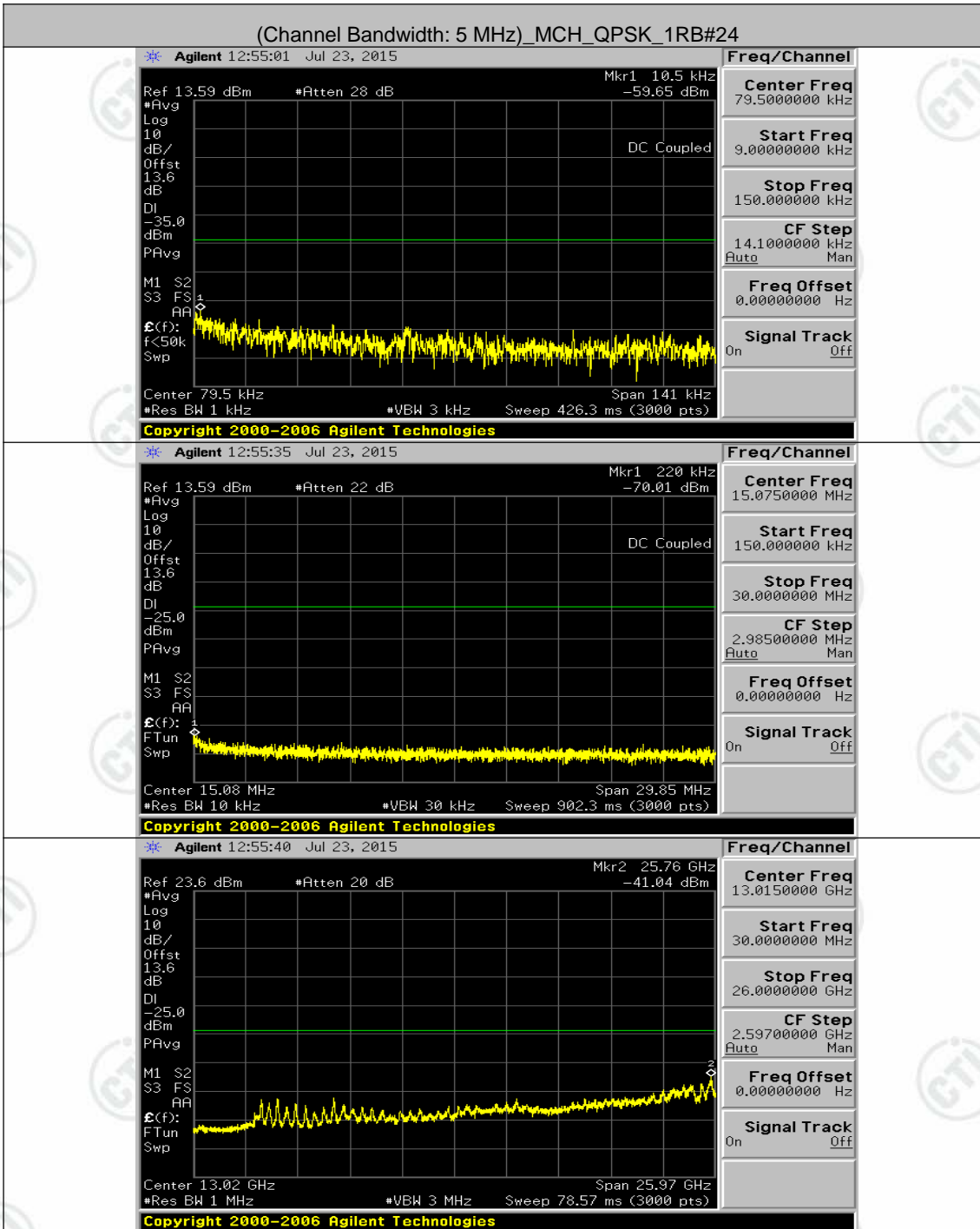

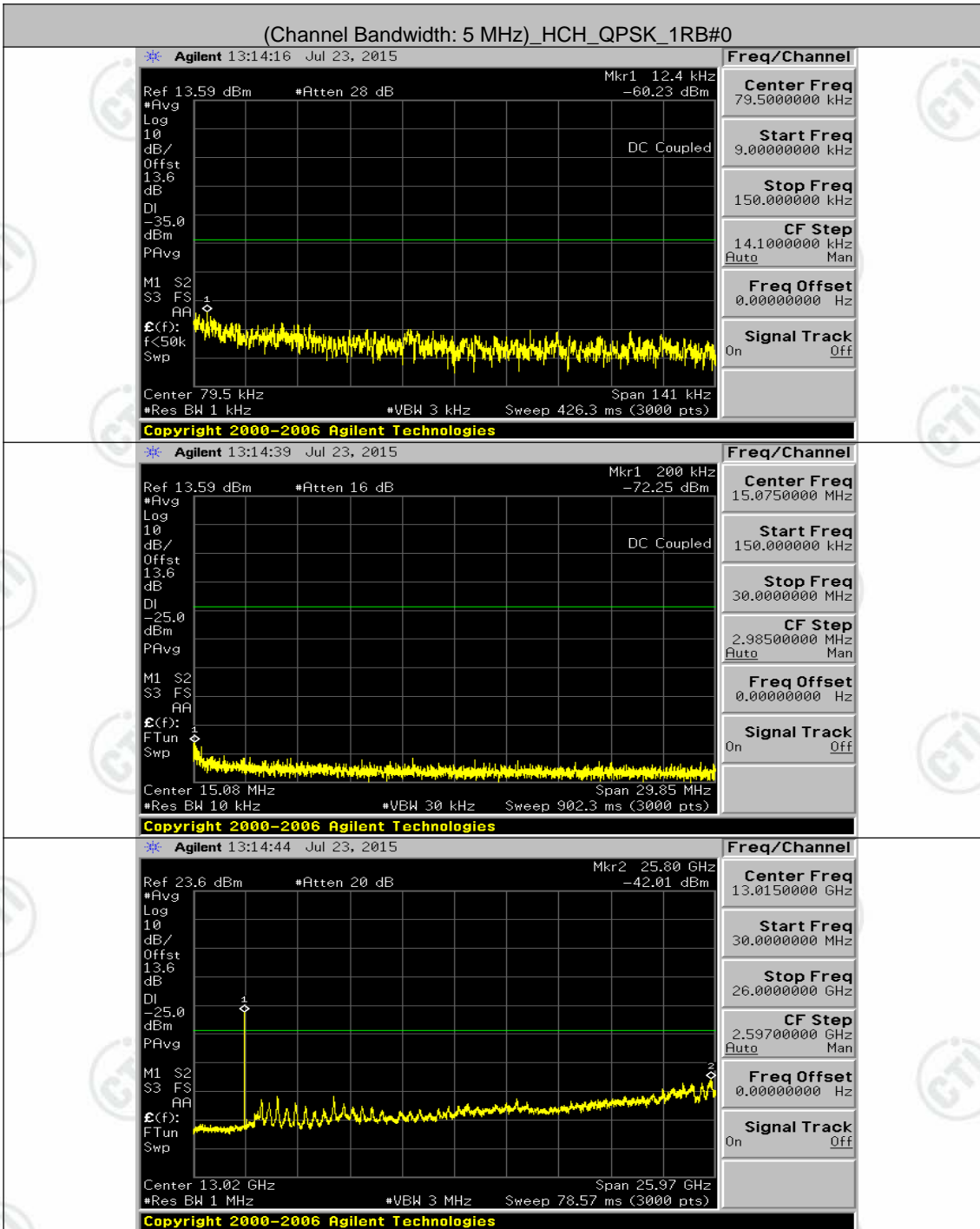

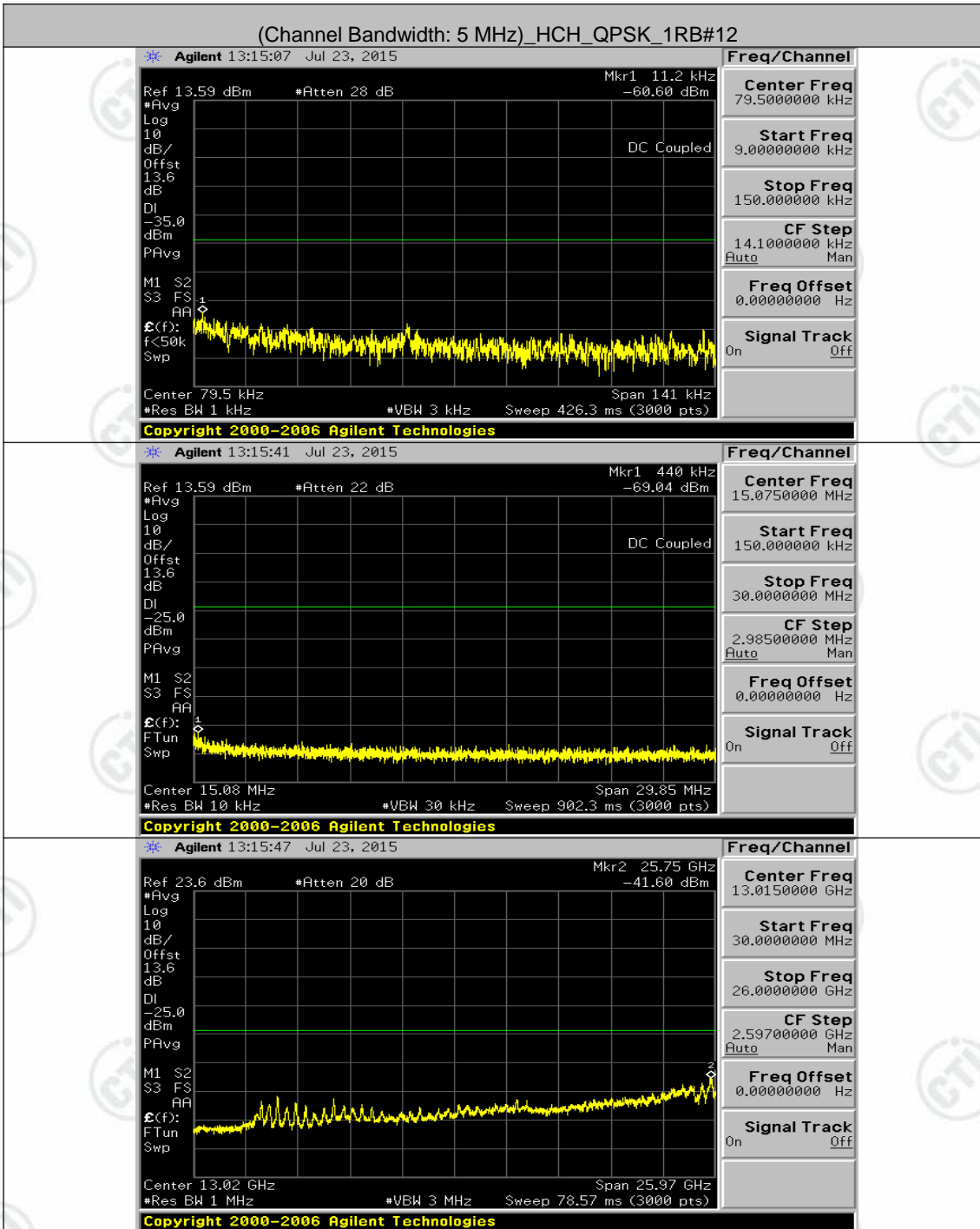

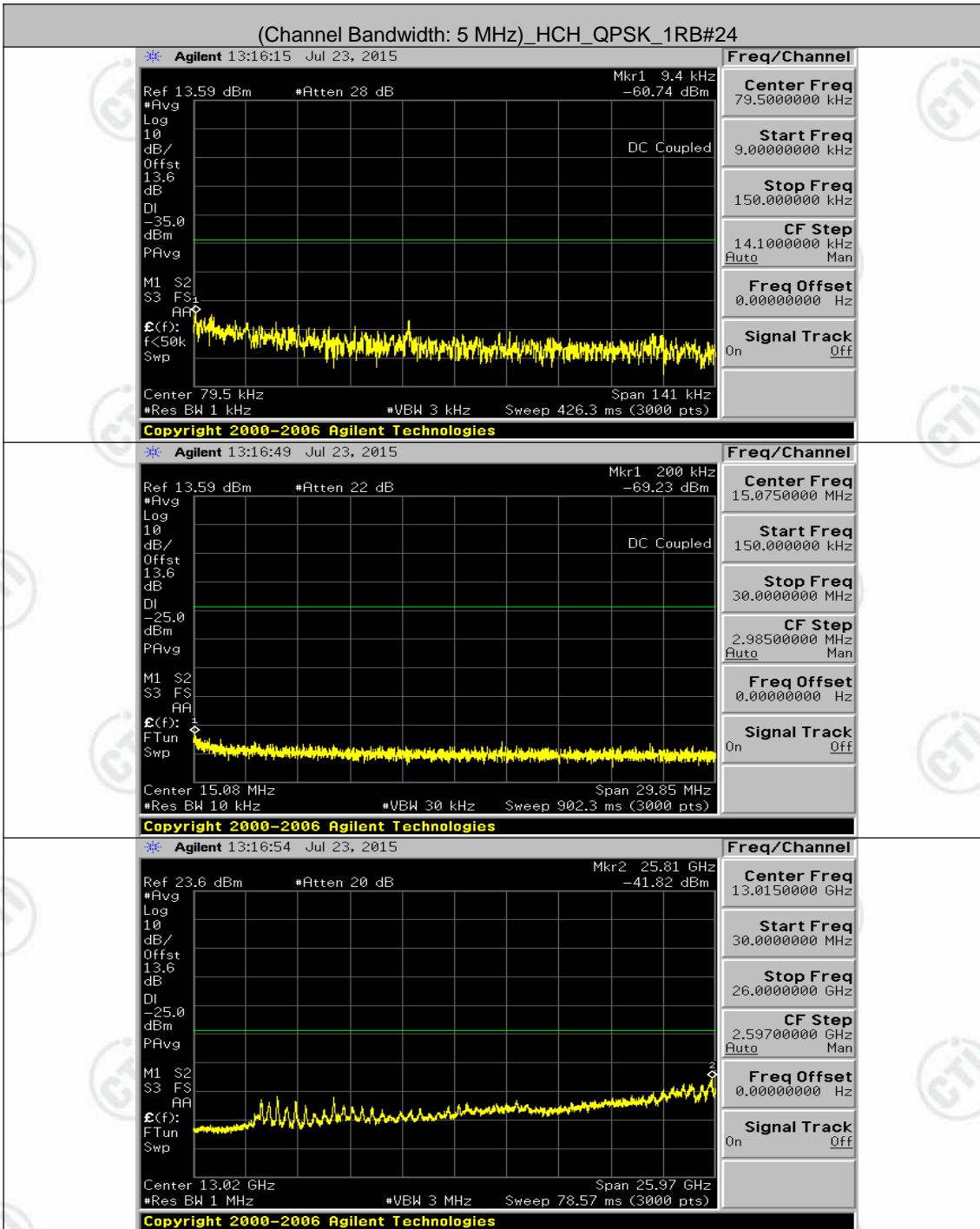

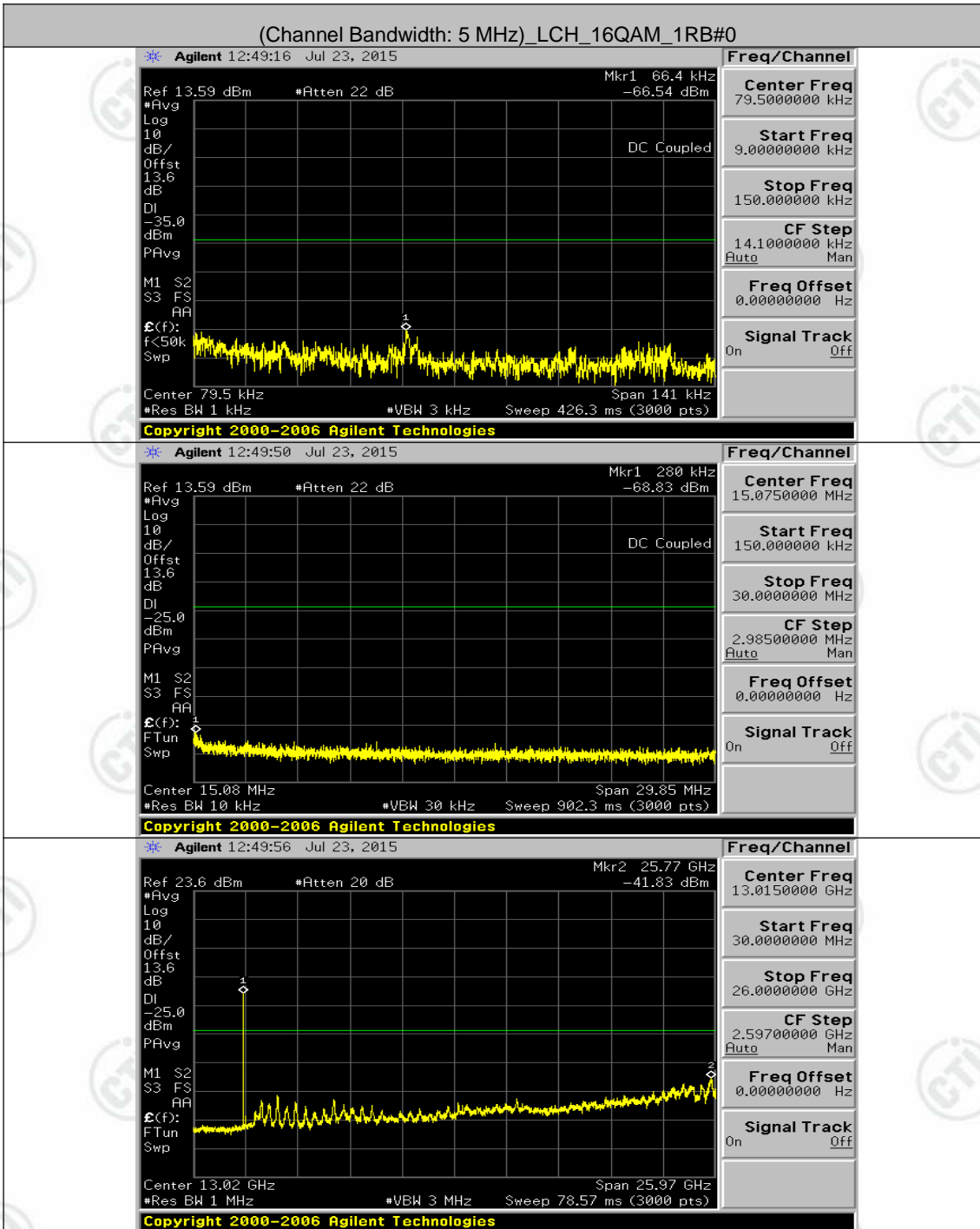

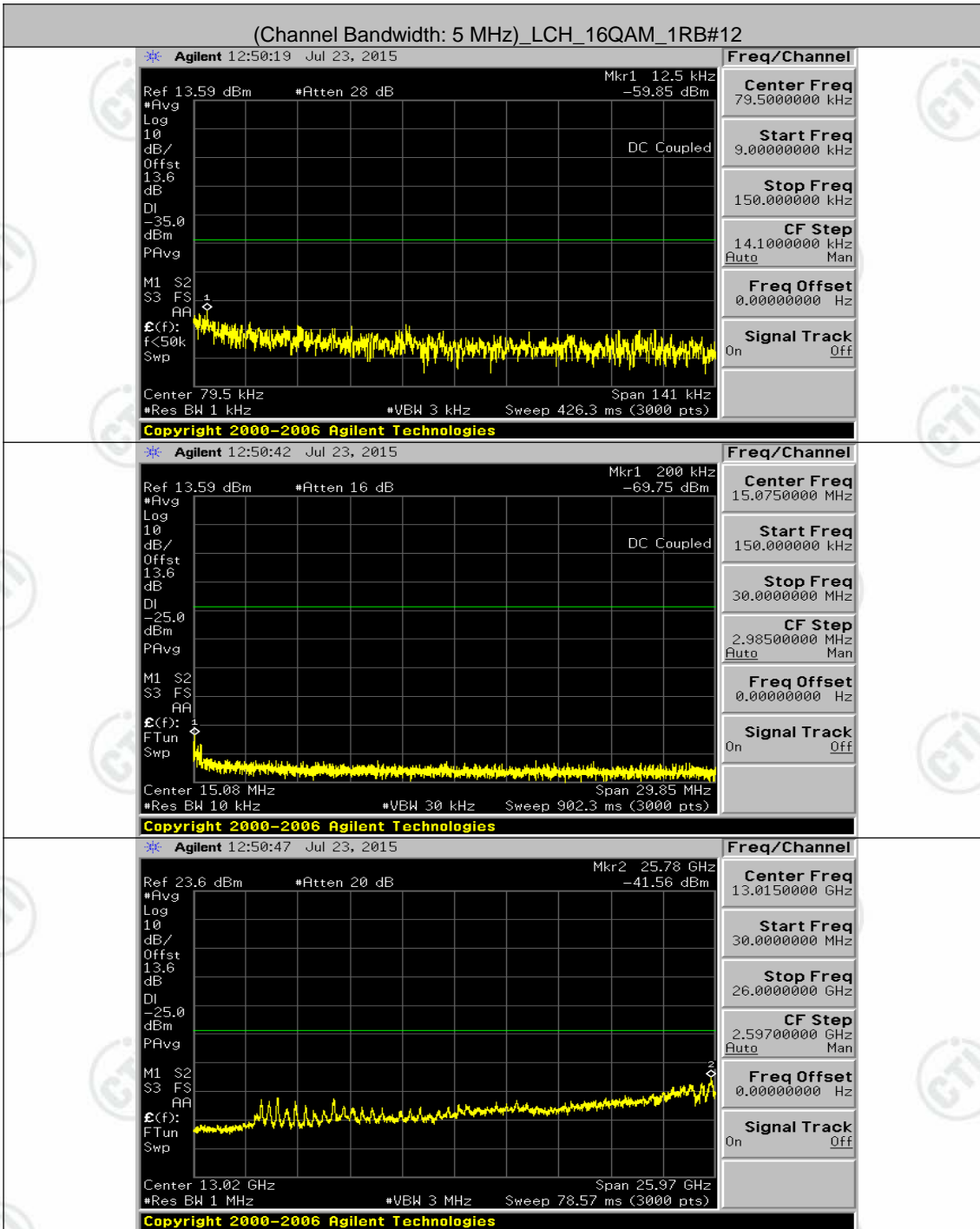

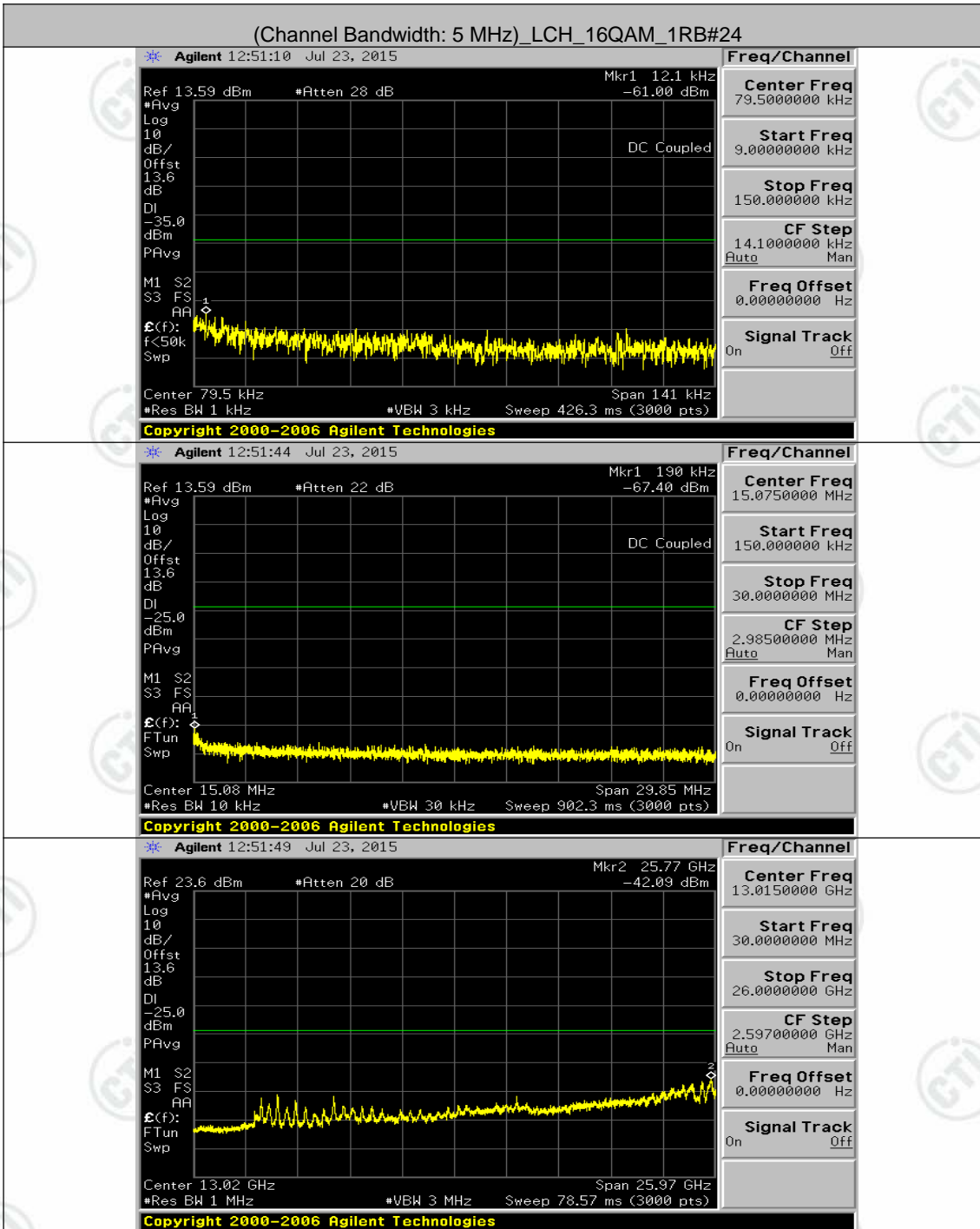

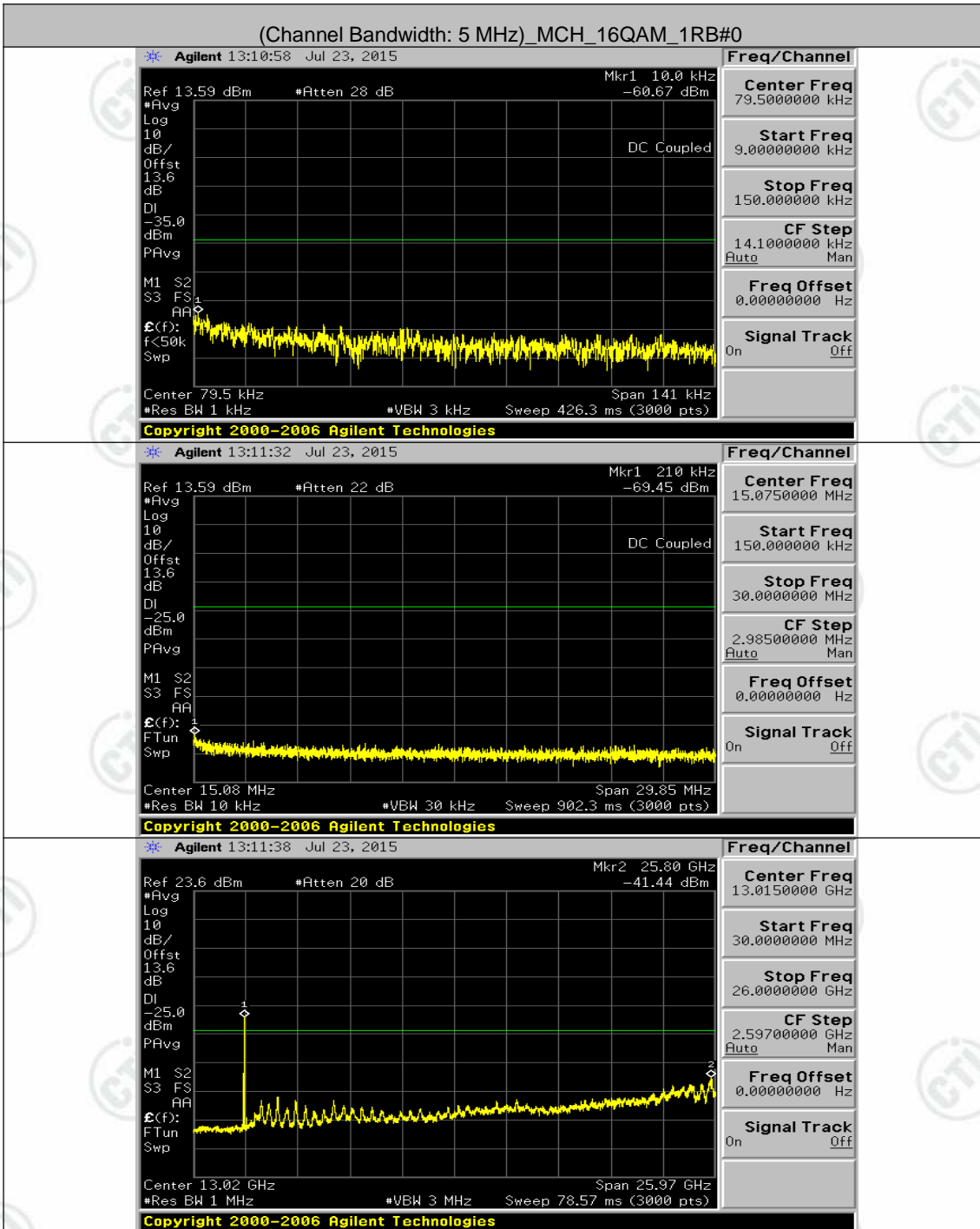

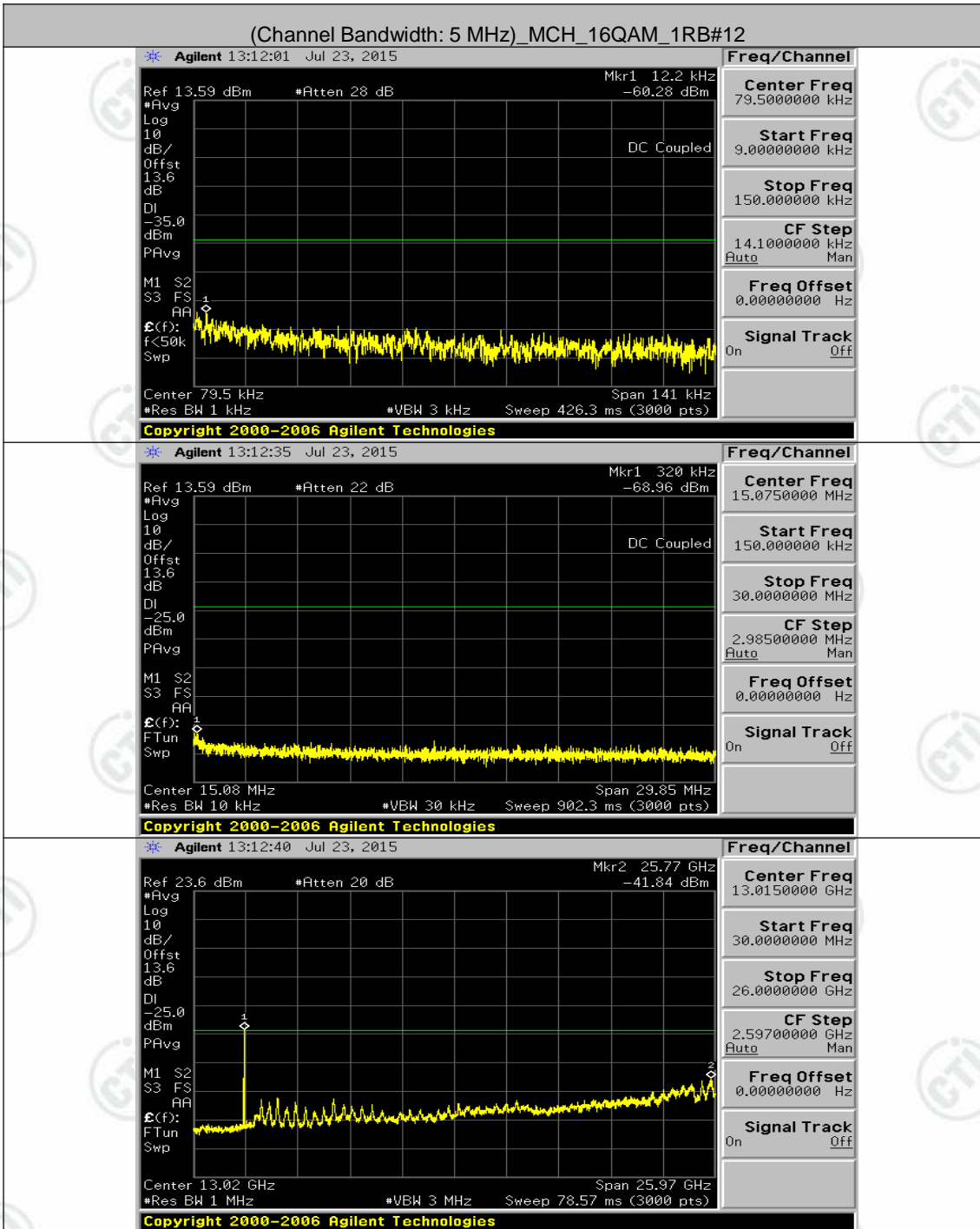

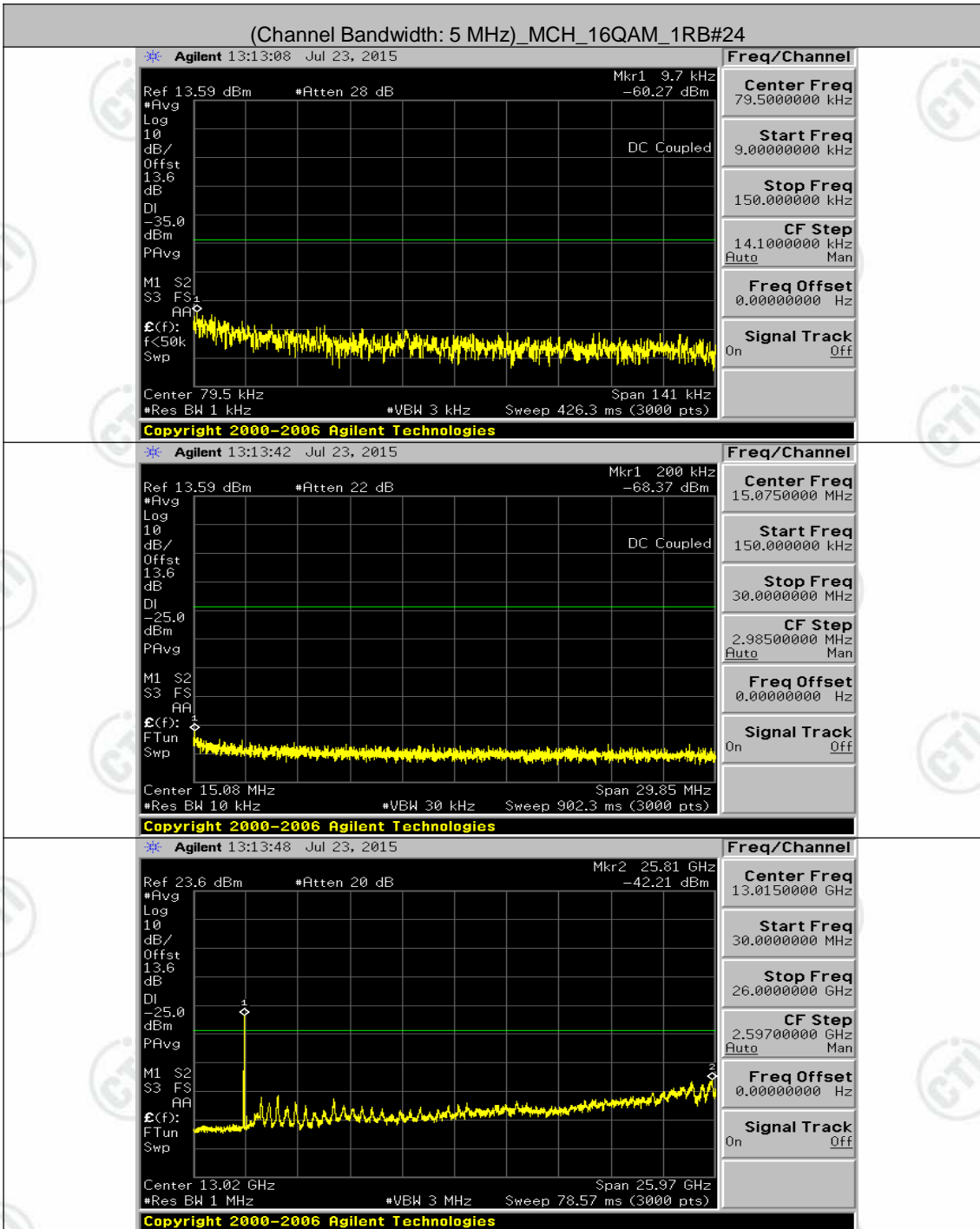

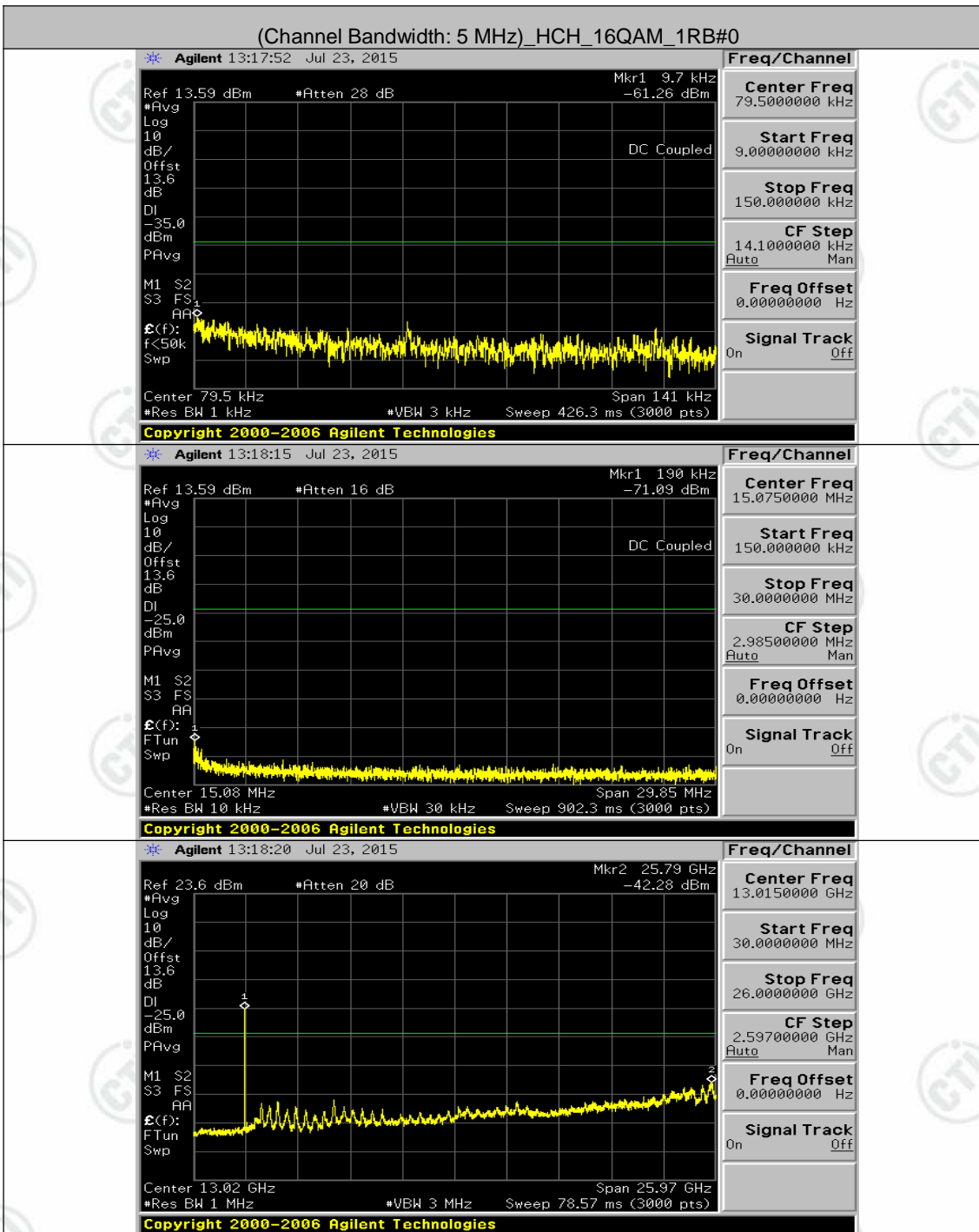

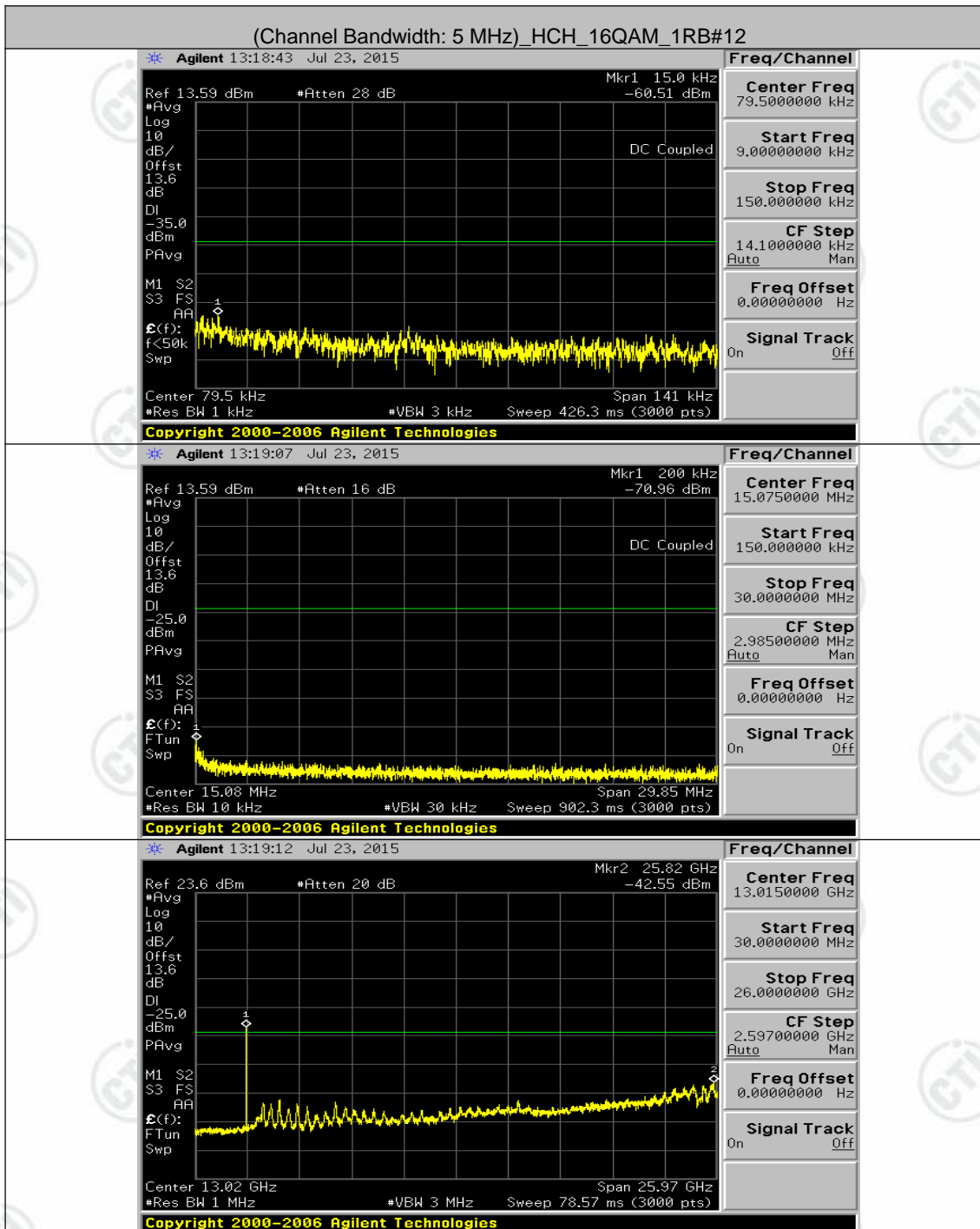

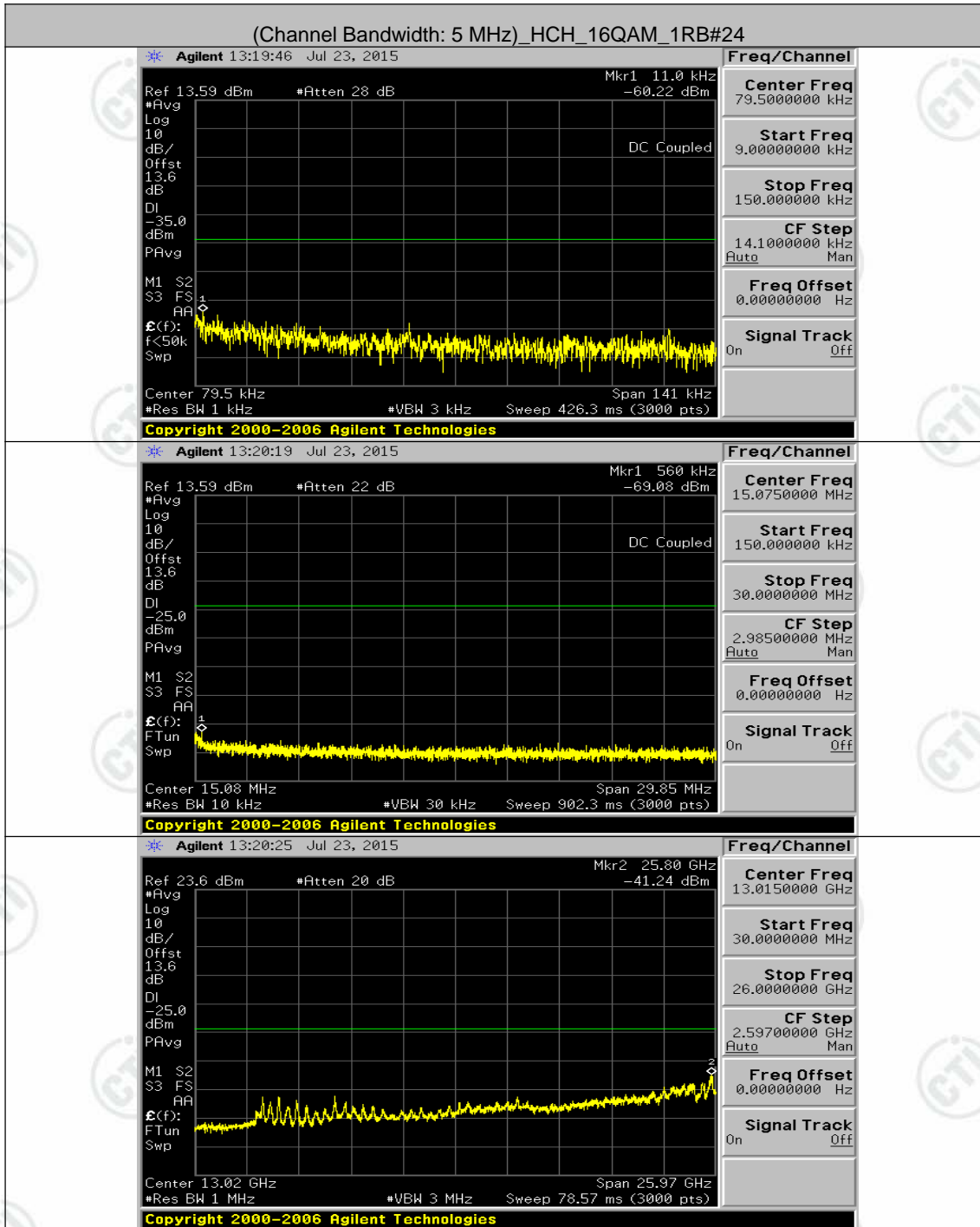

Channel Bandwidth: 10 MHz

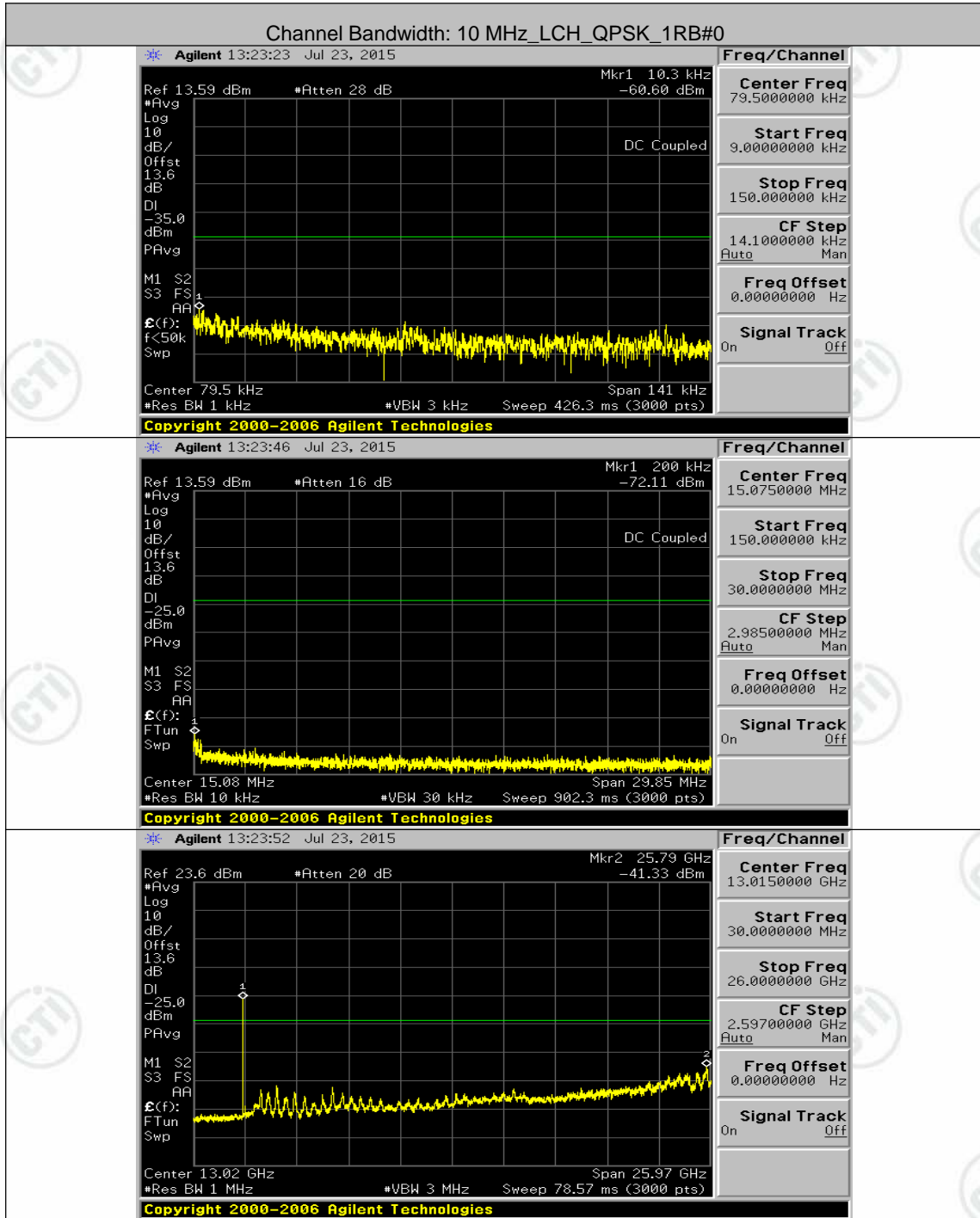

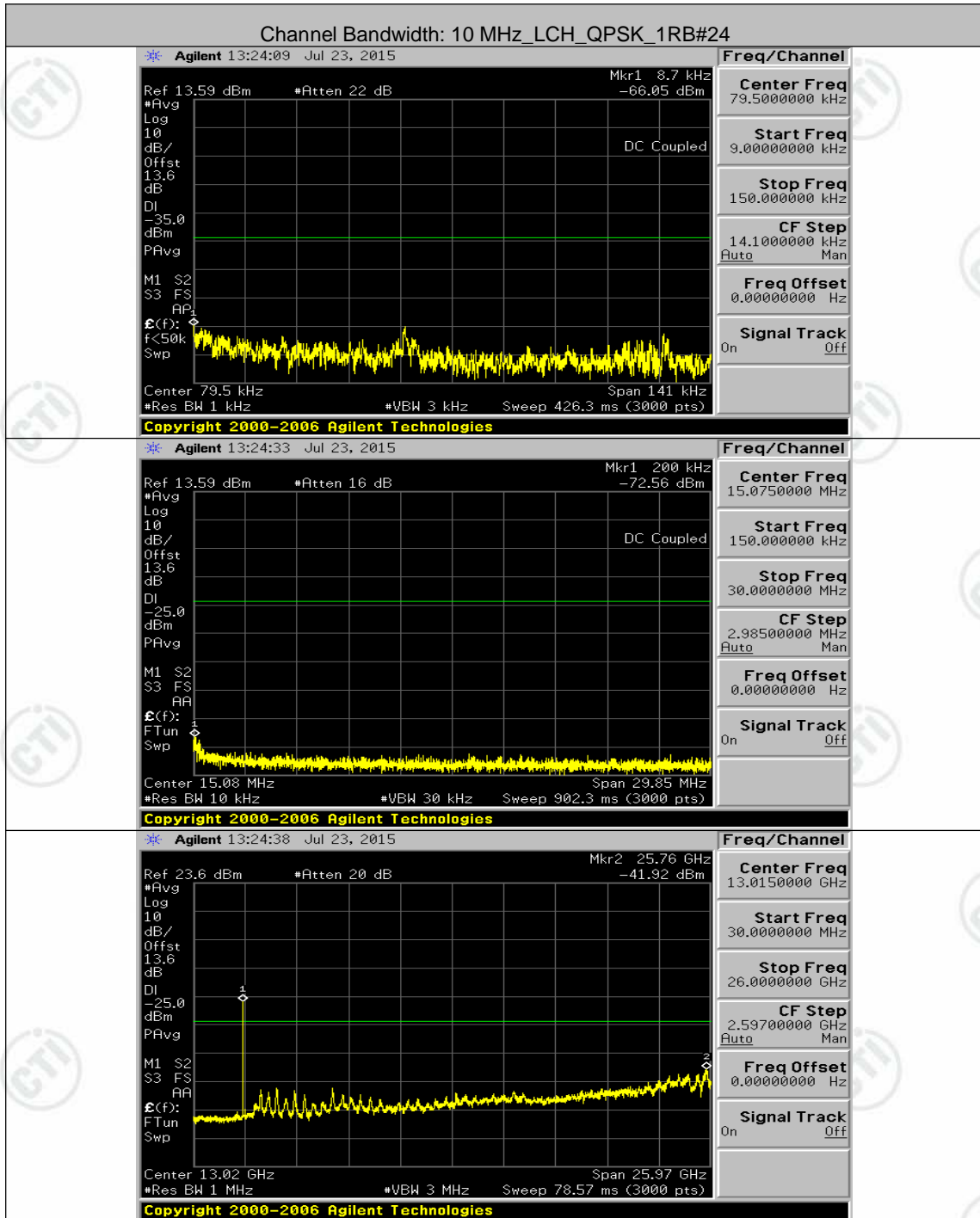

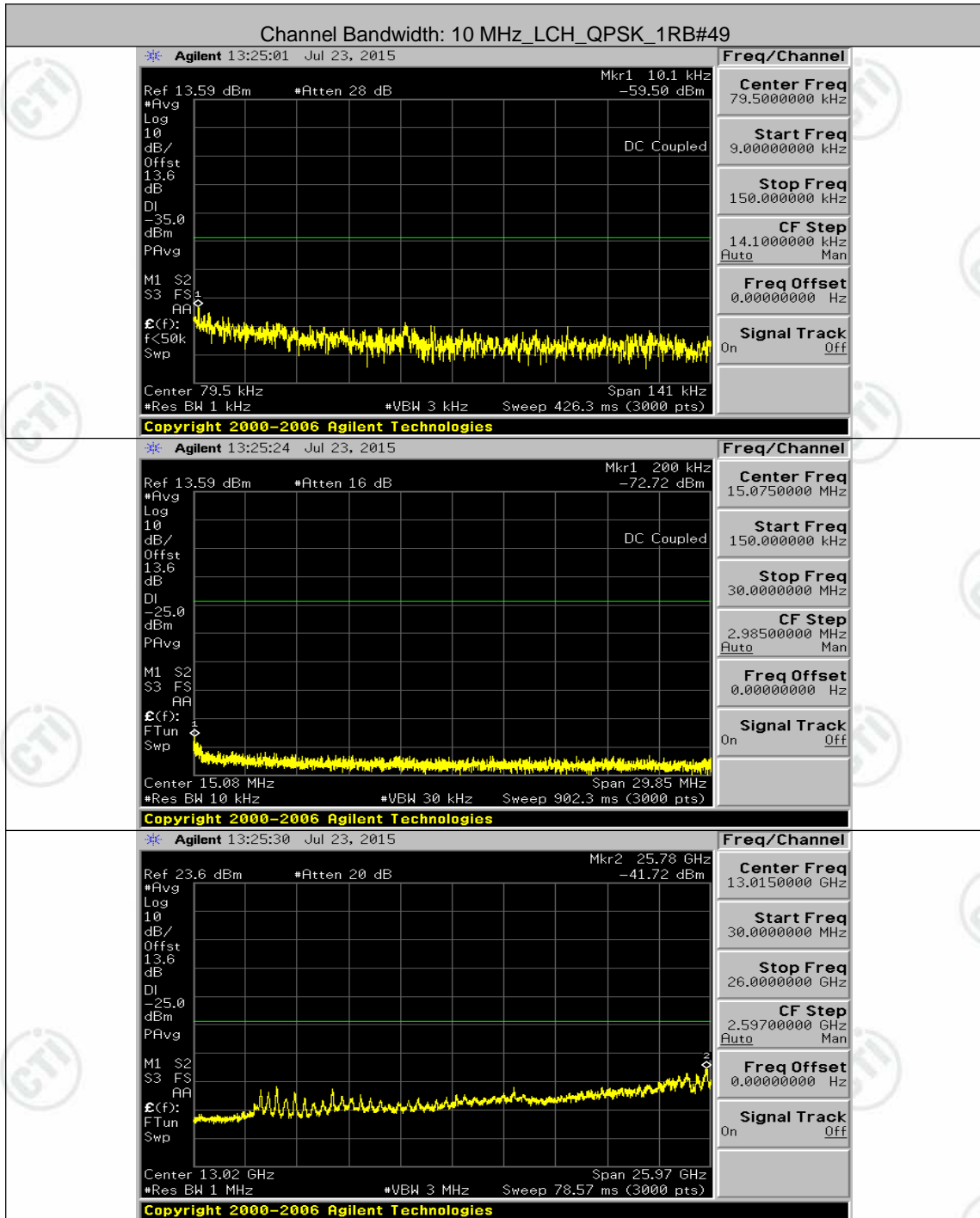

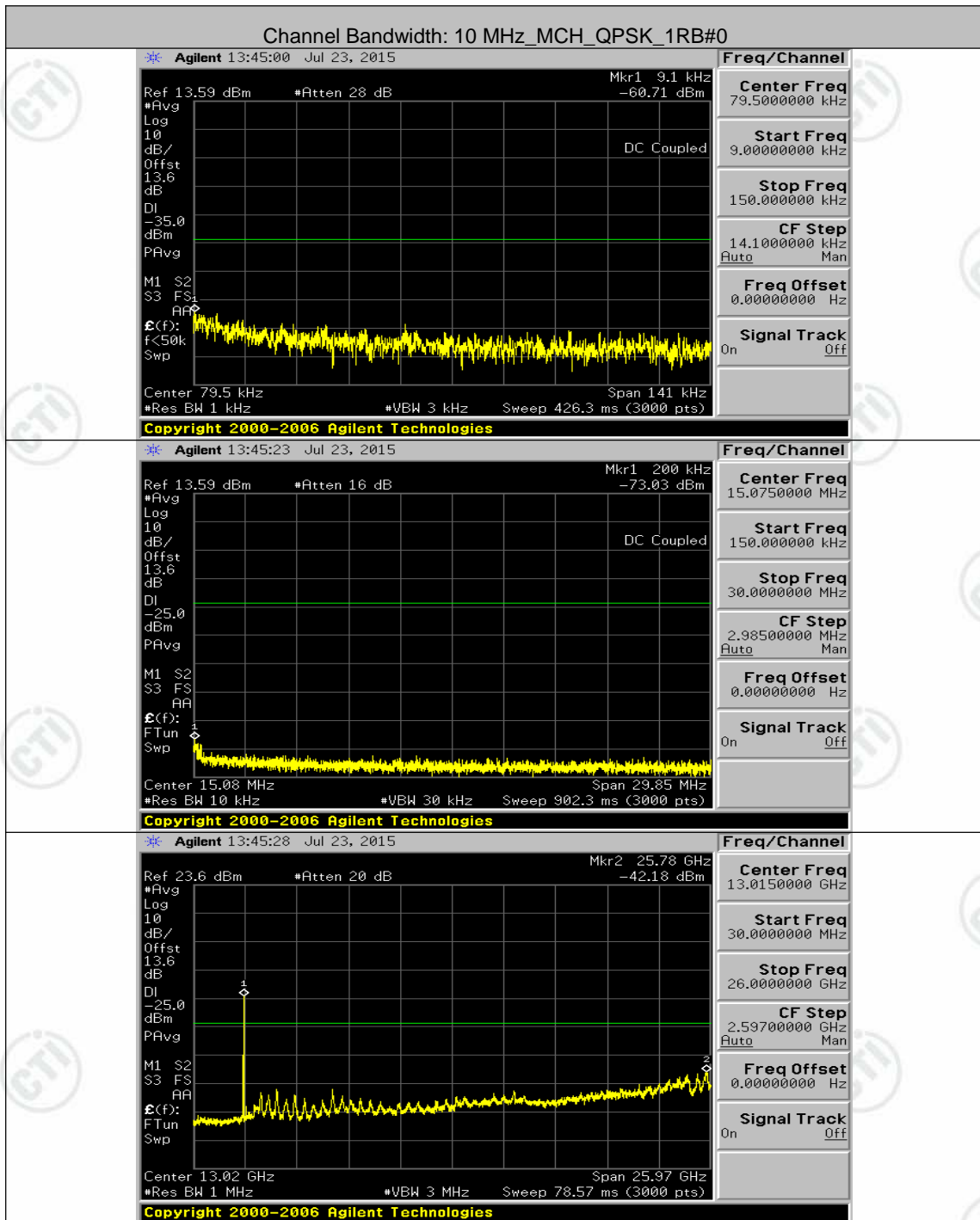

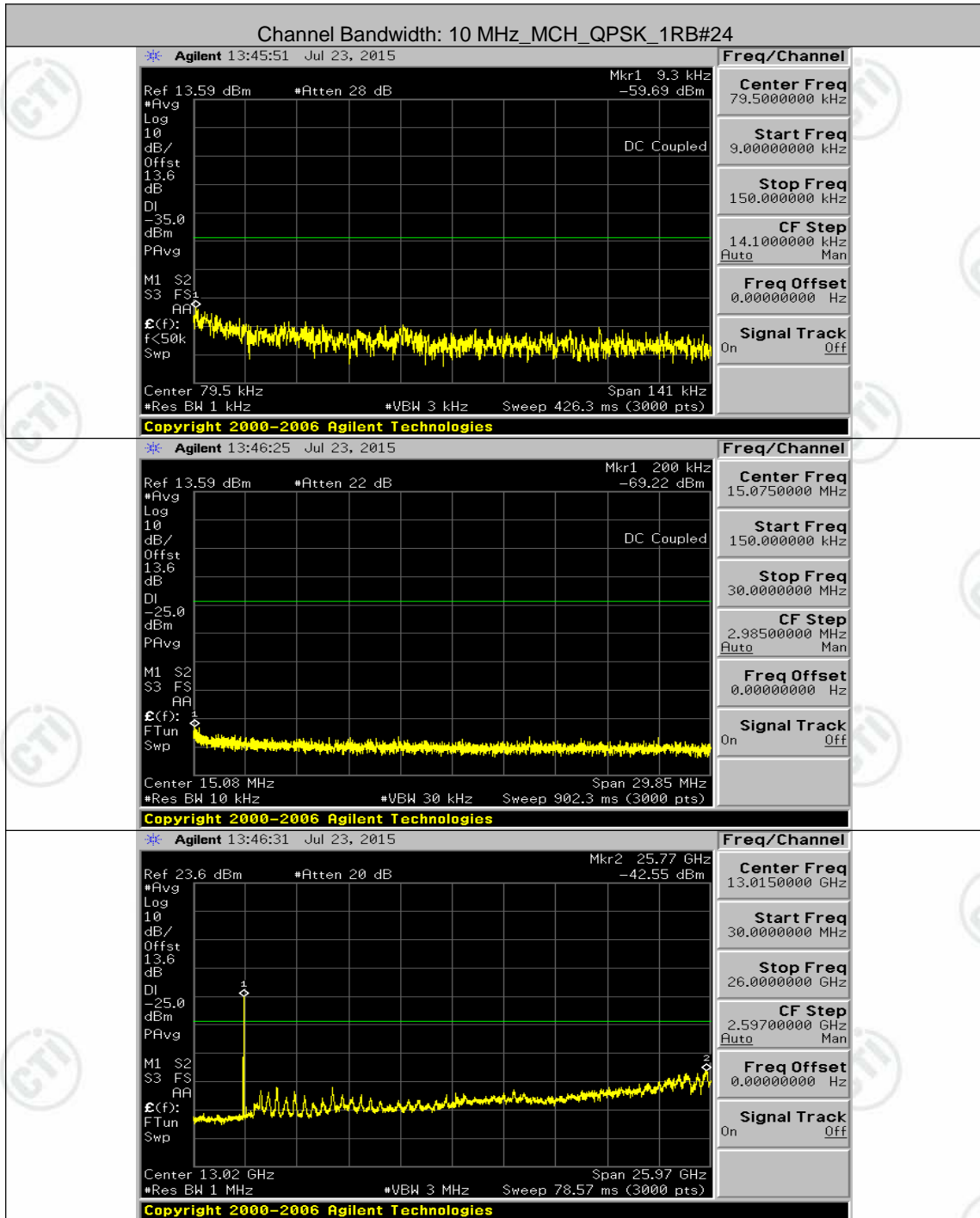

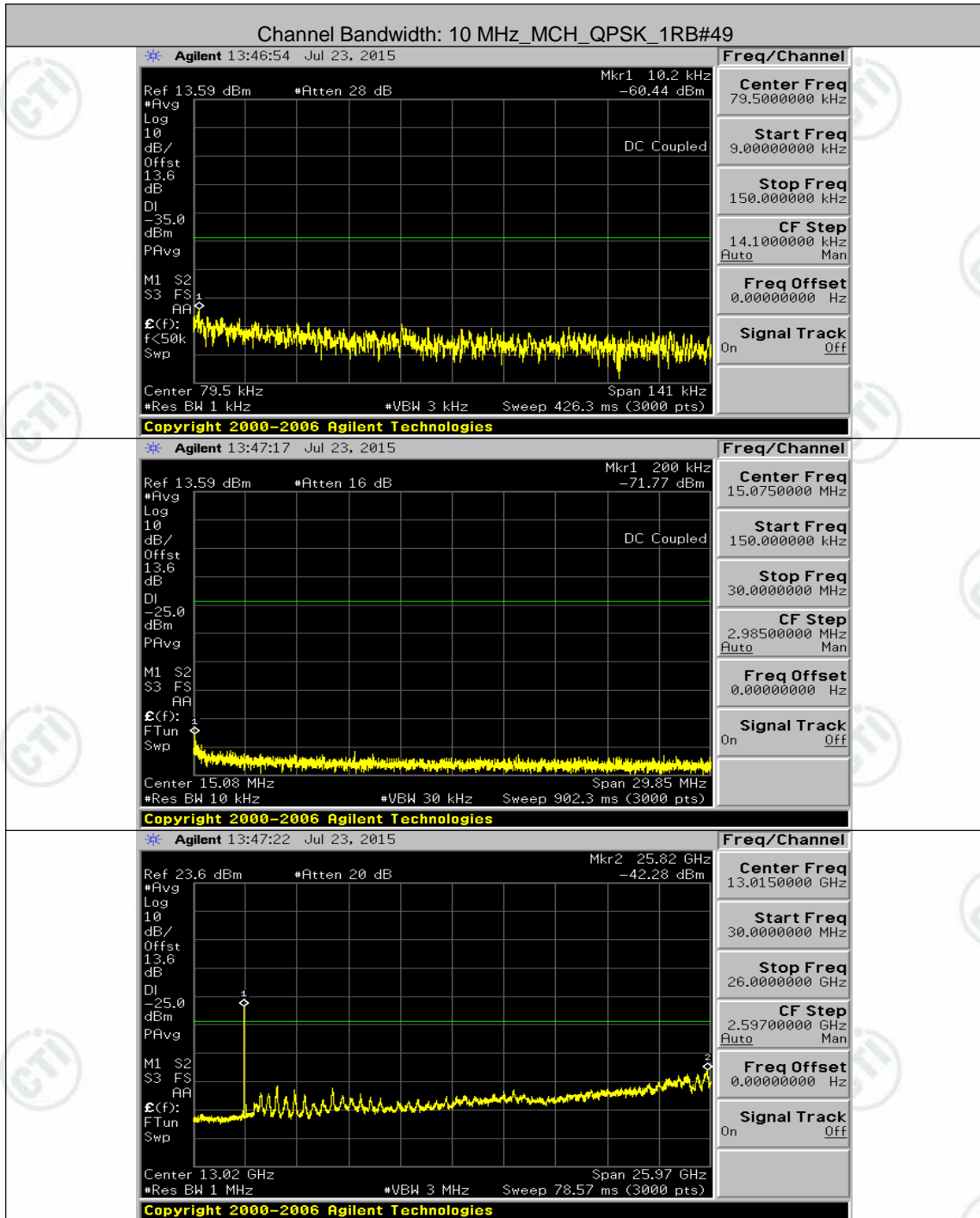

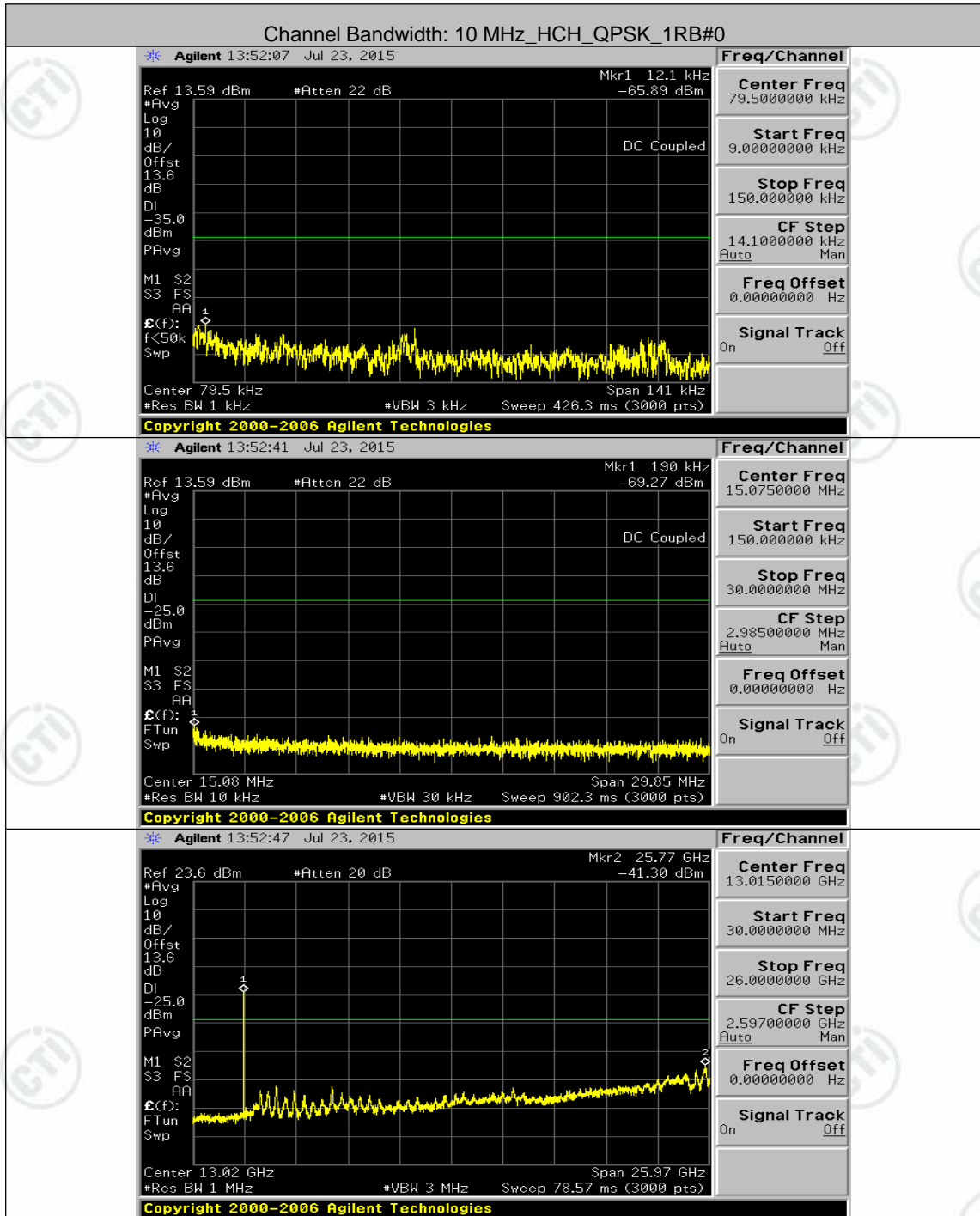

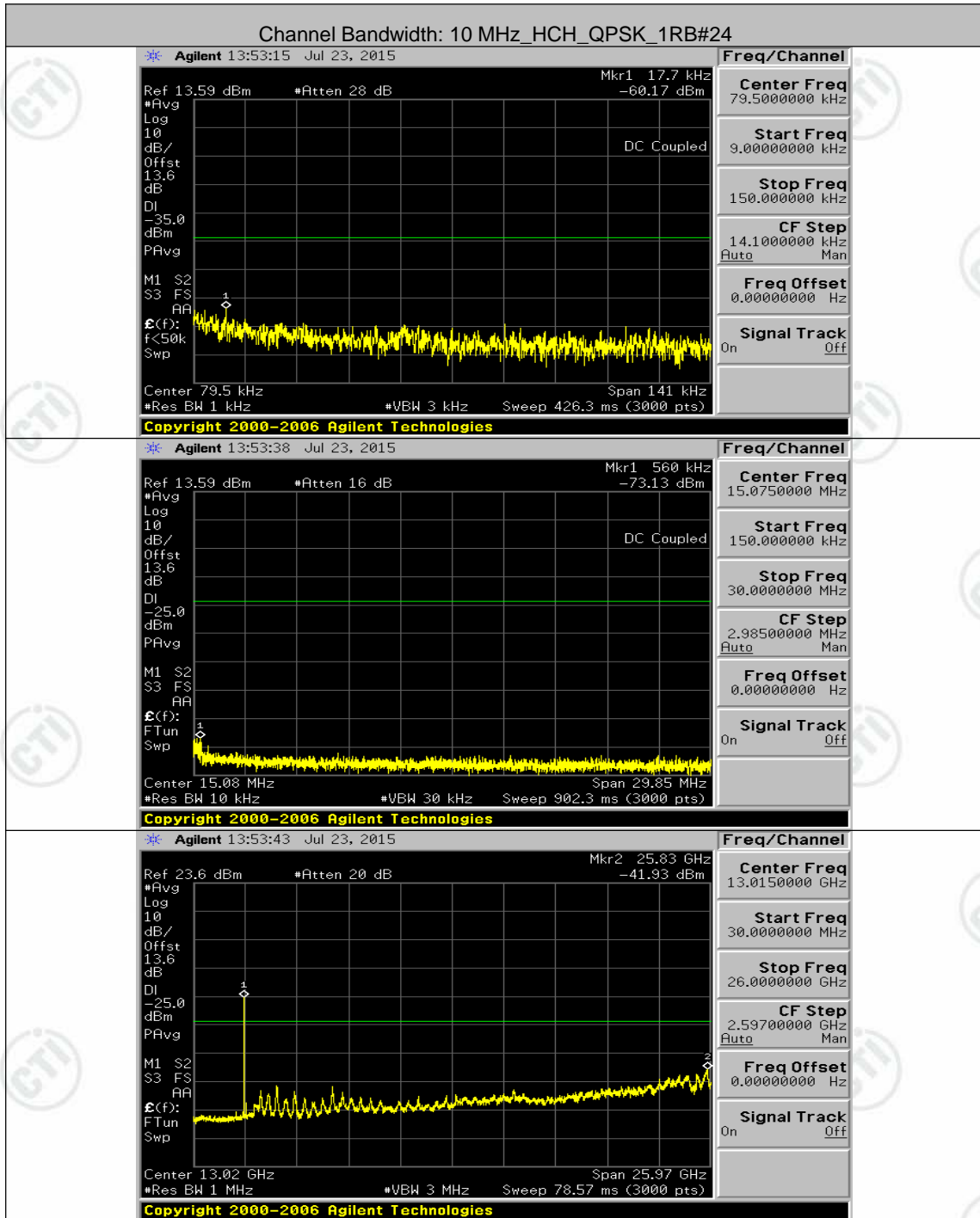

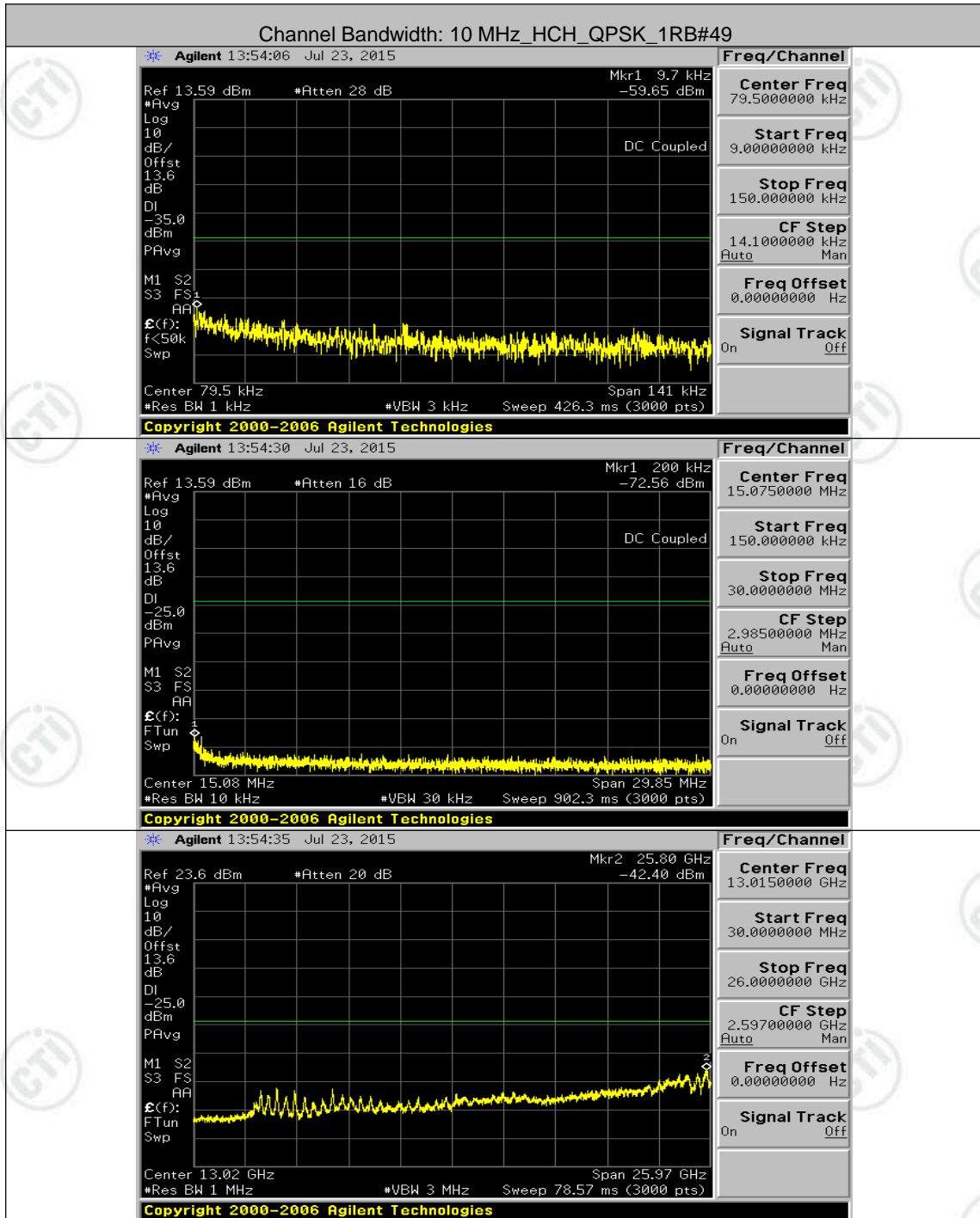

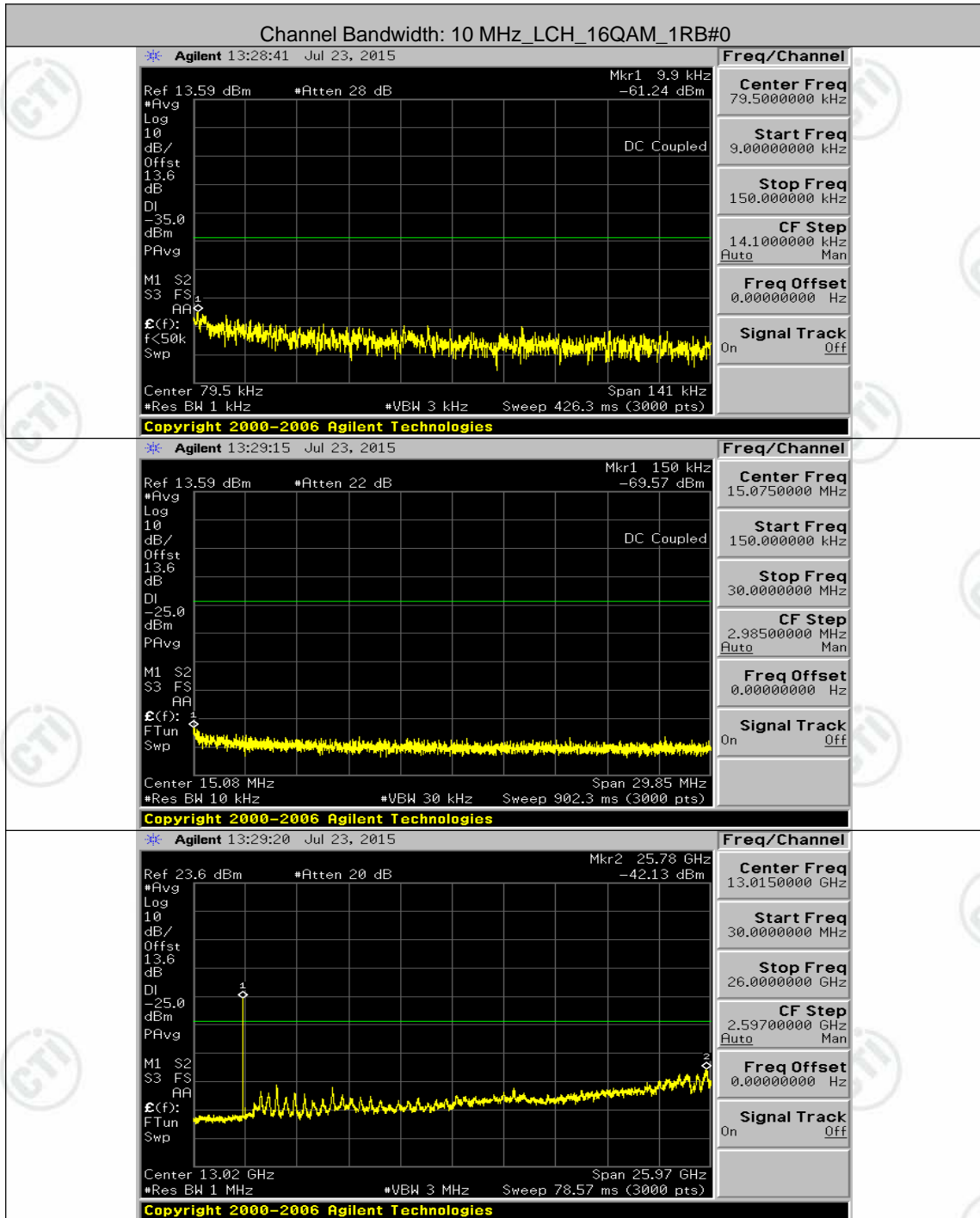

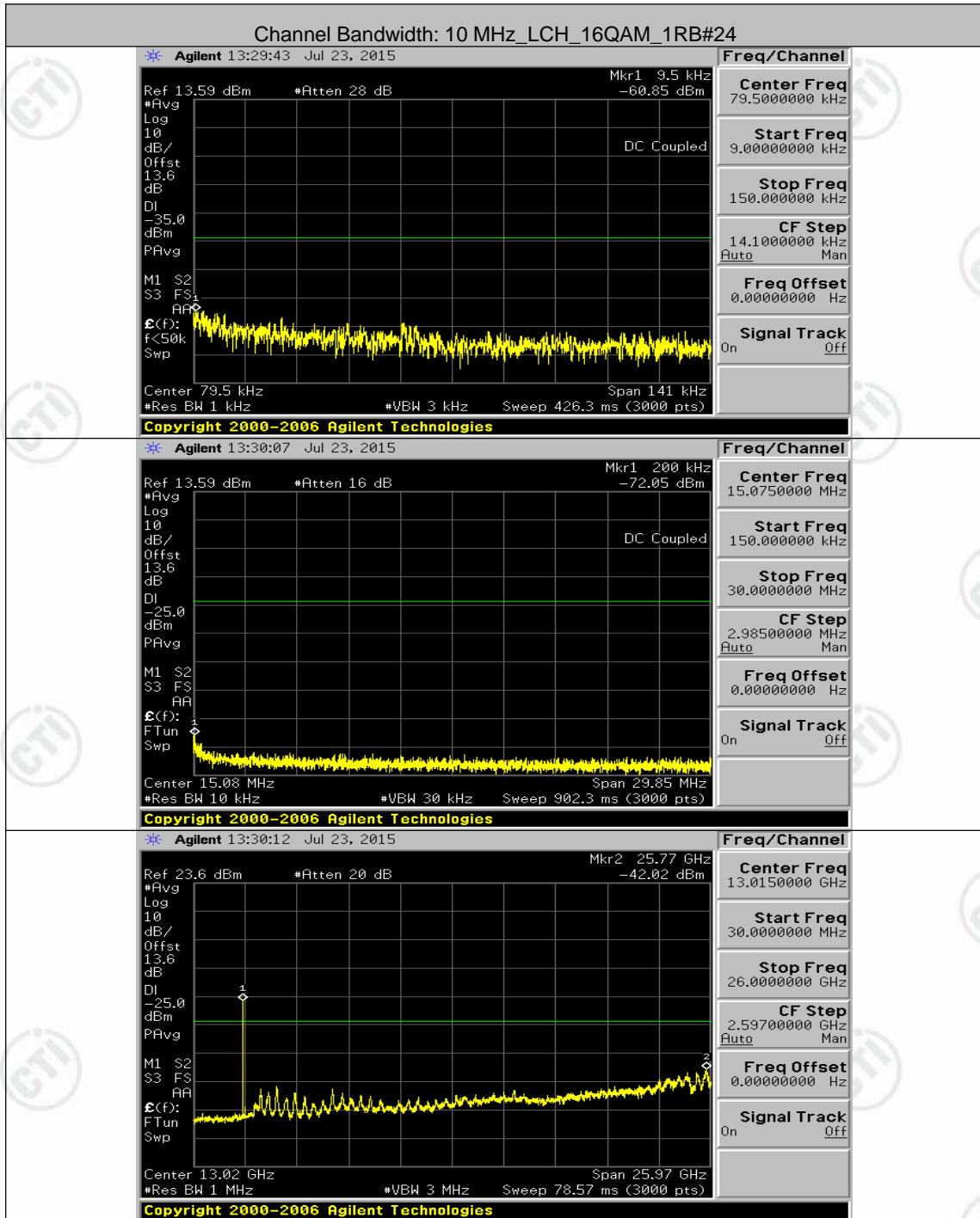

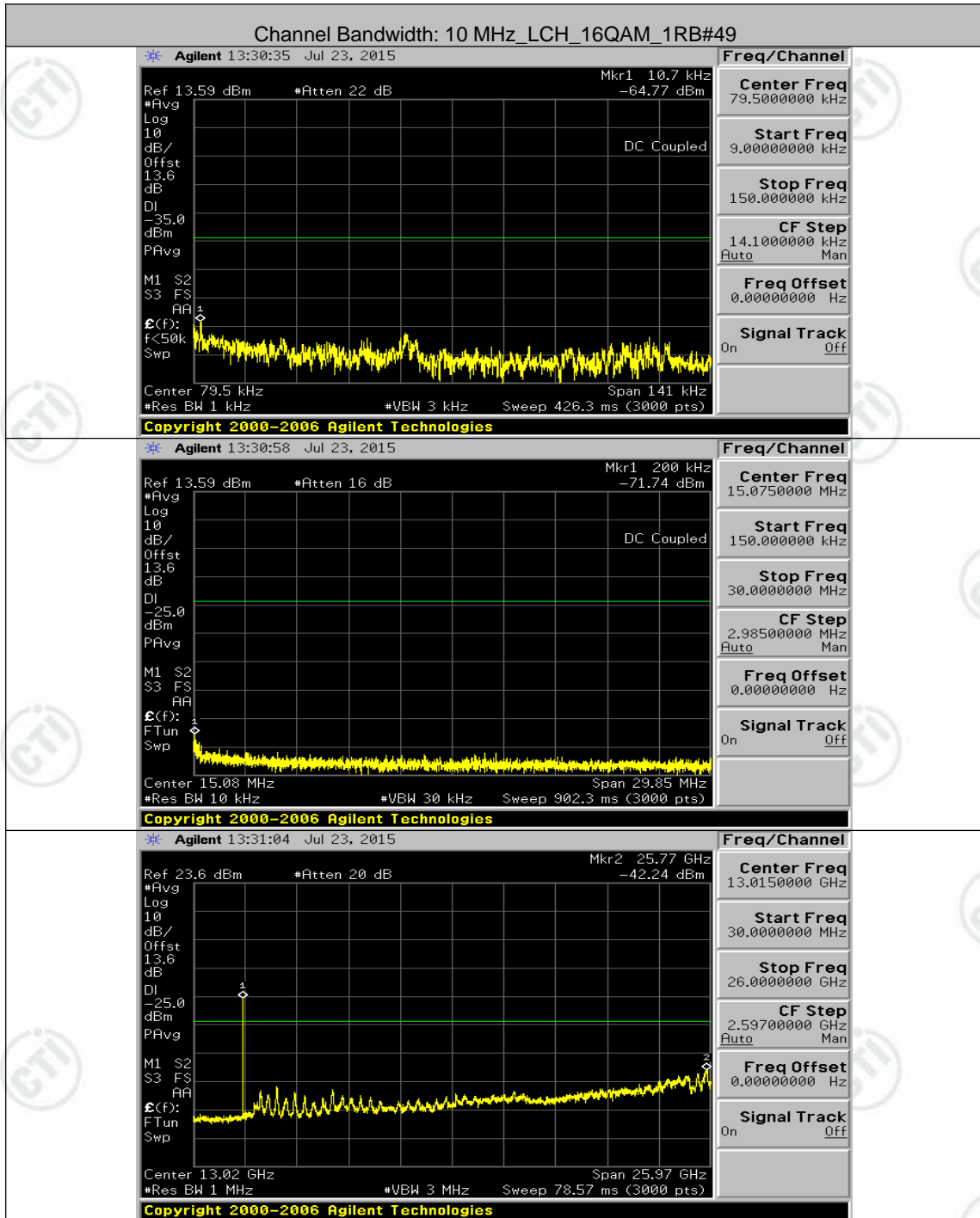

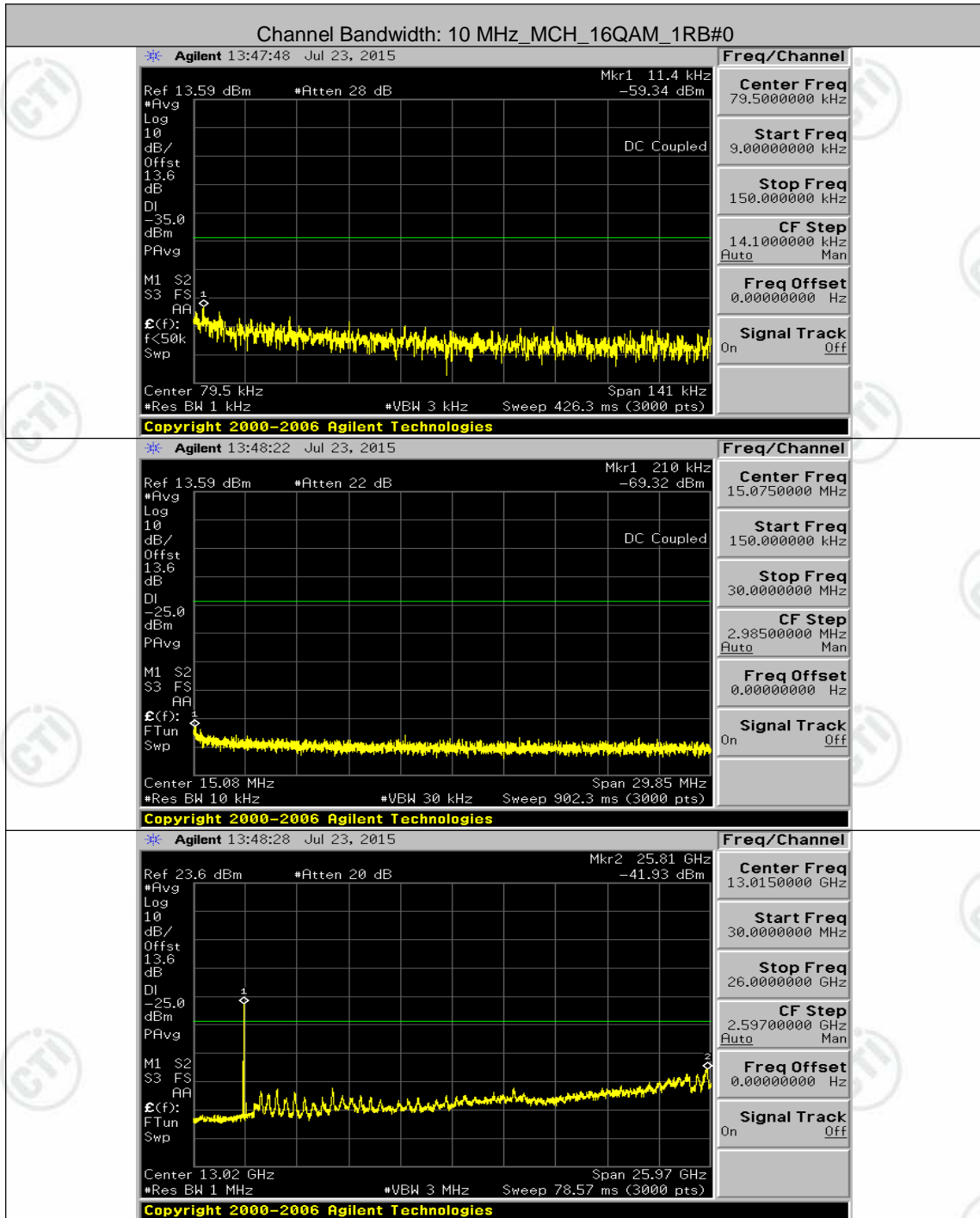

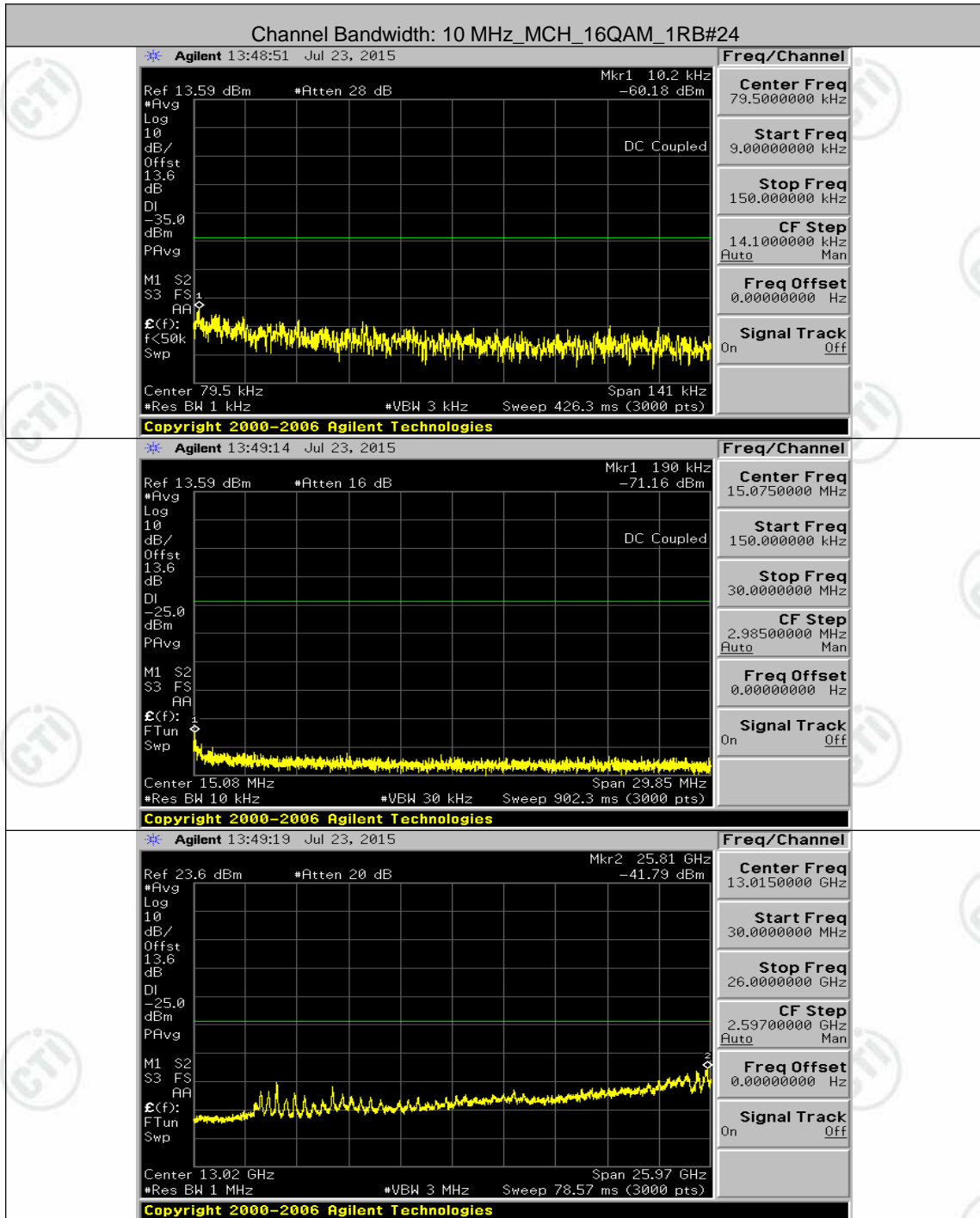

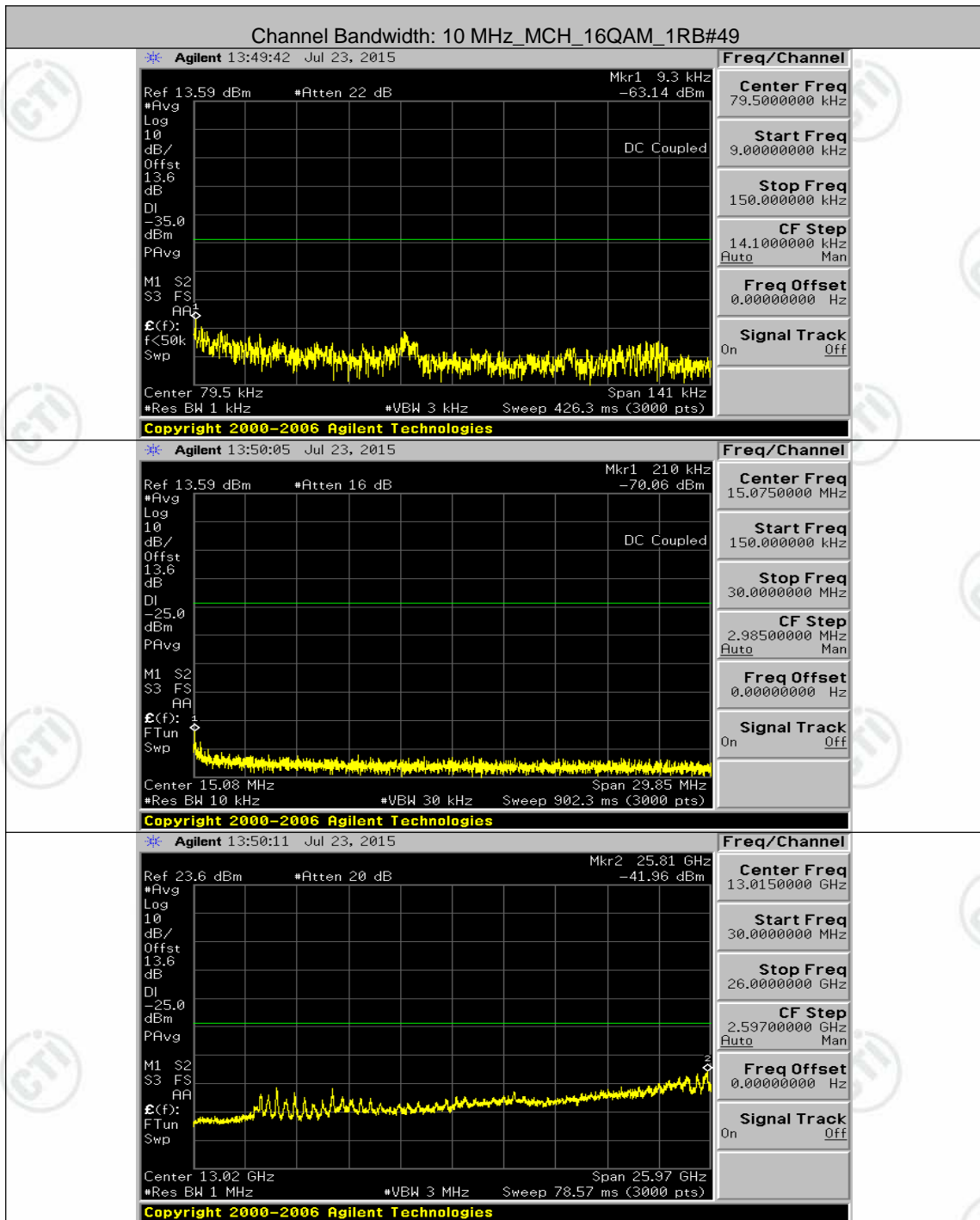

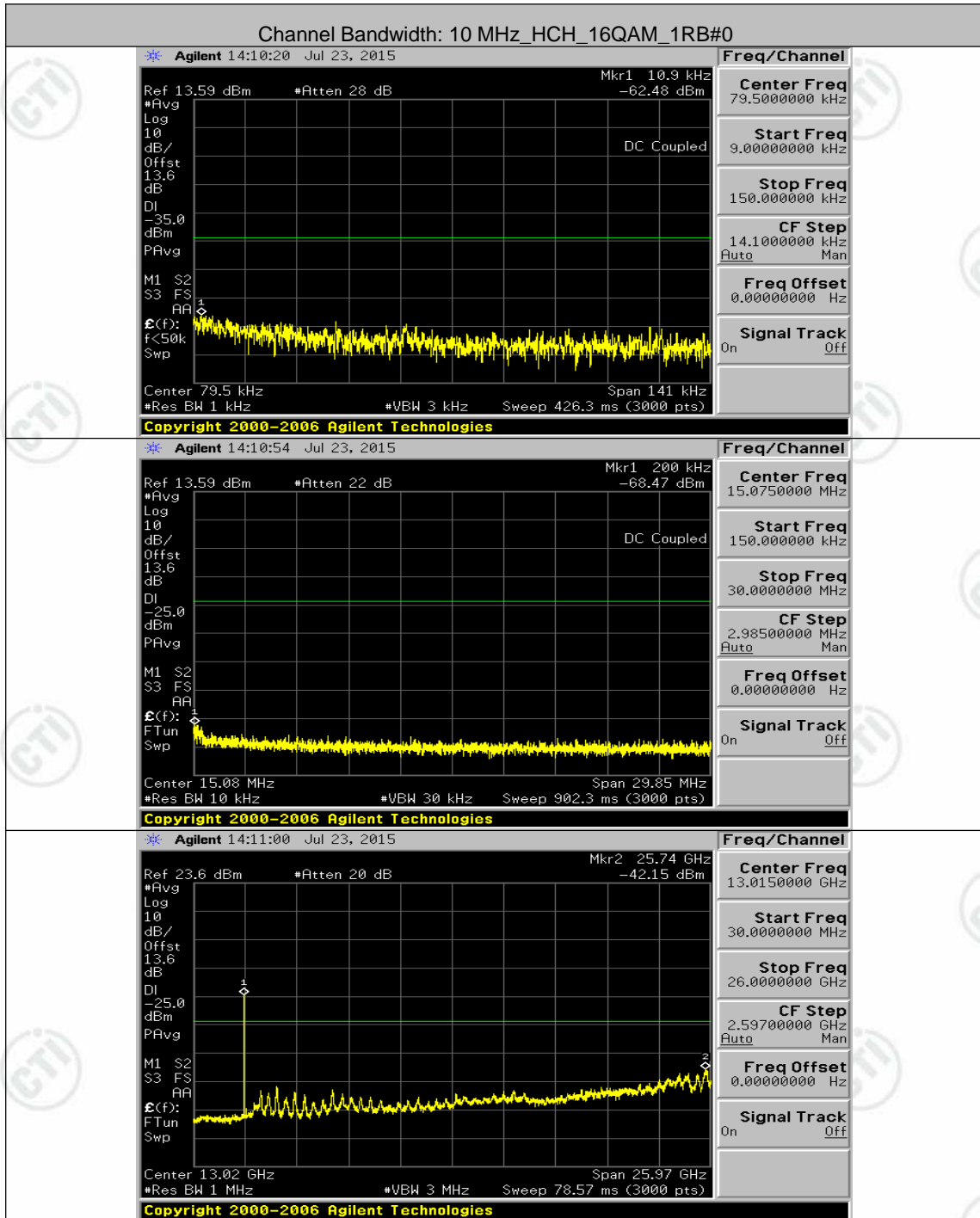

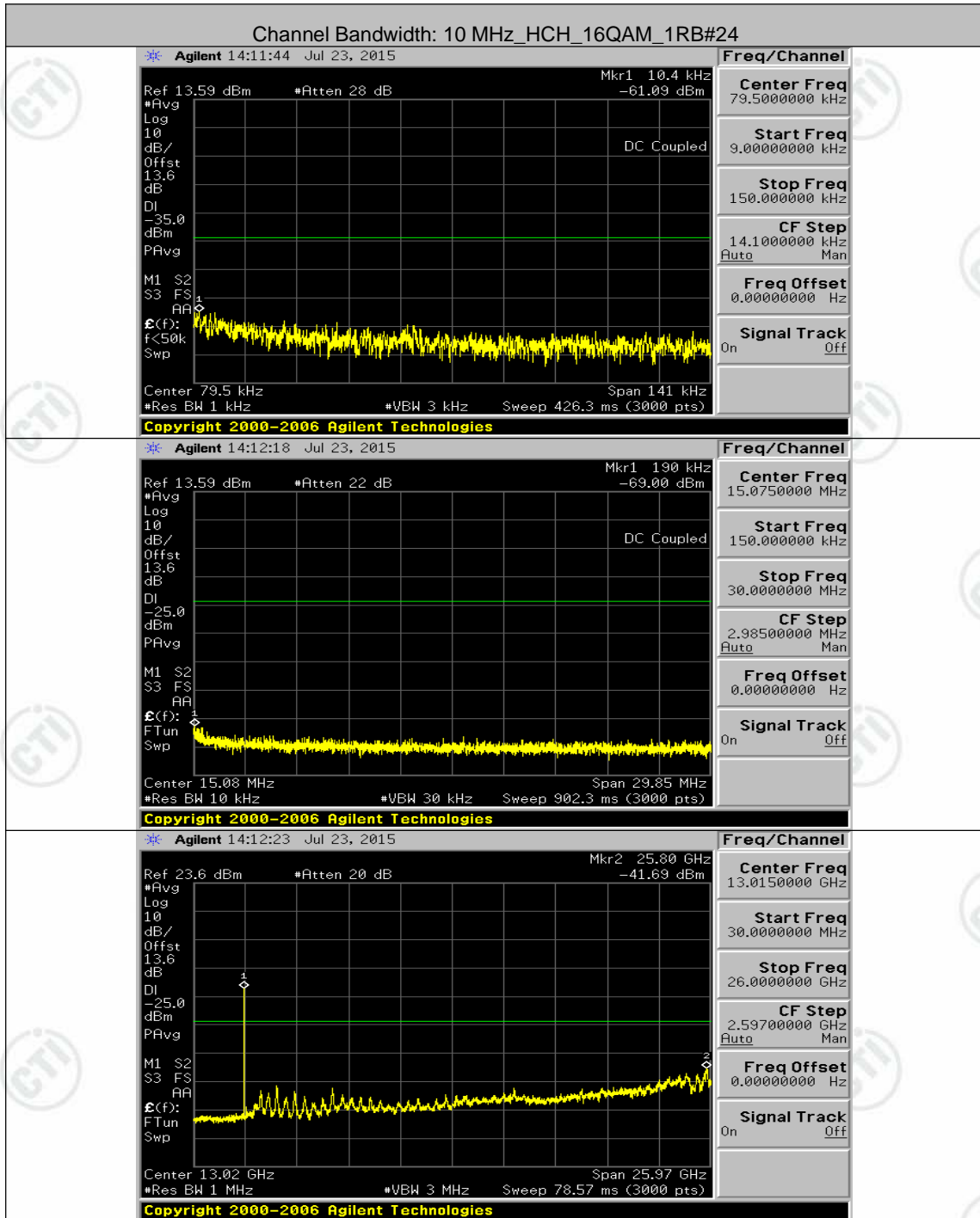

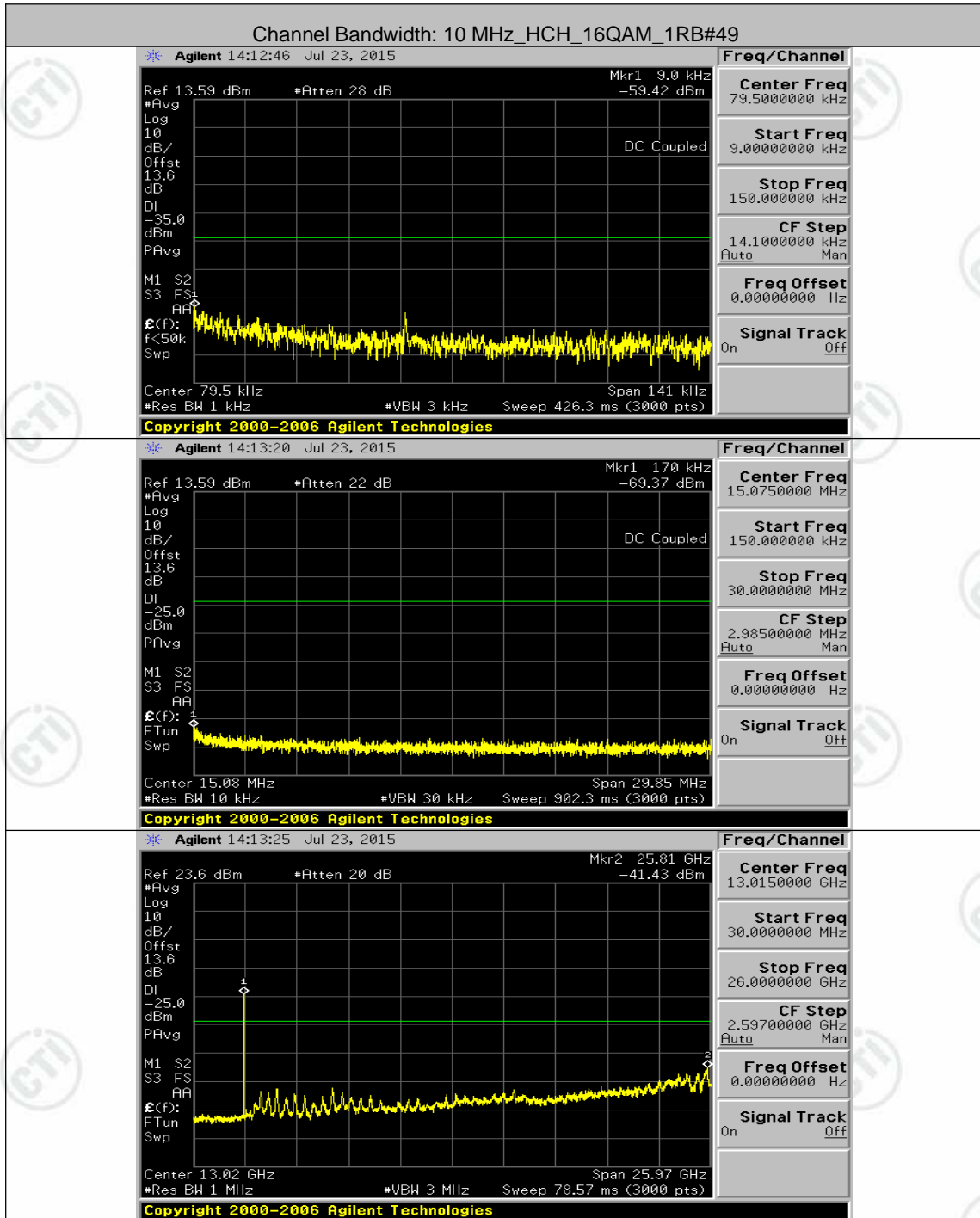

Channel Bandwidth: 15 MHz

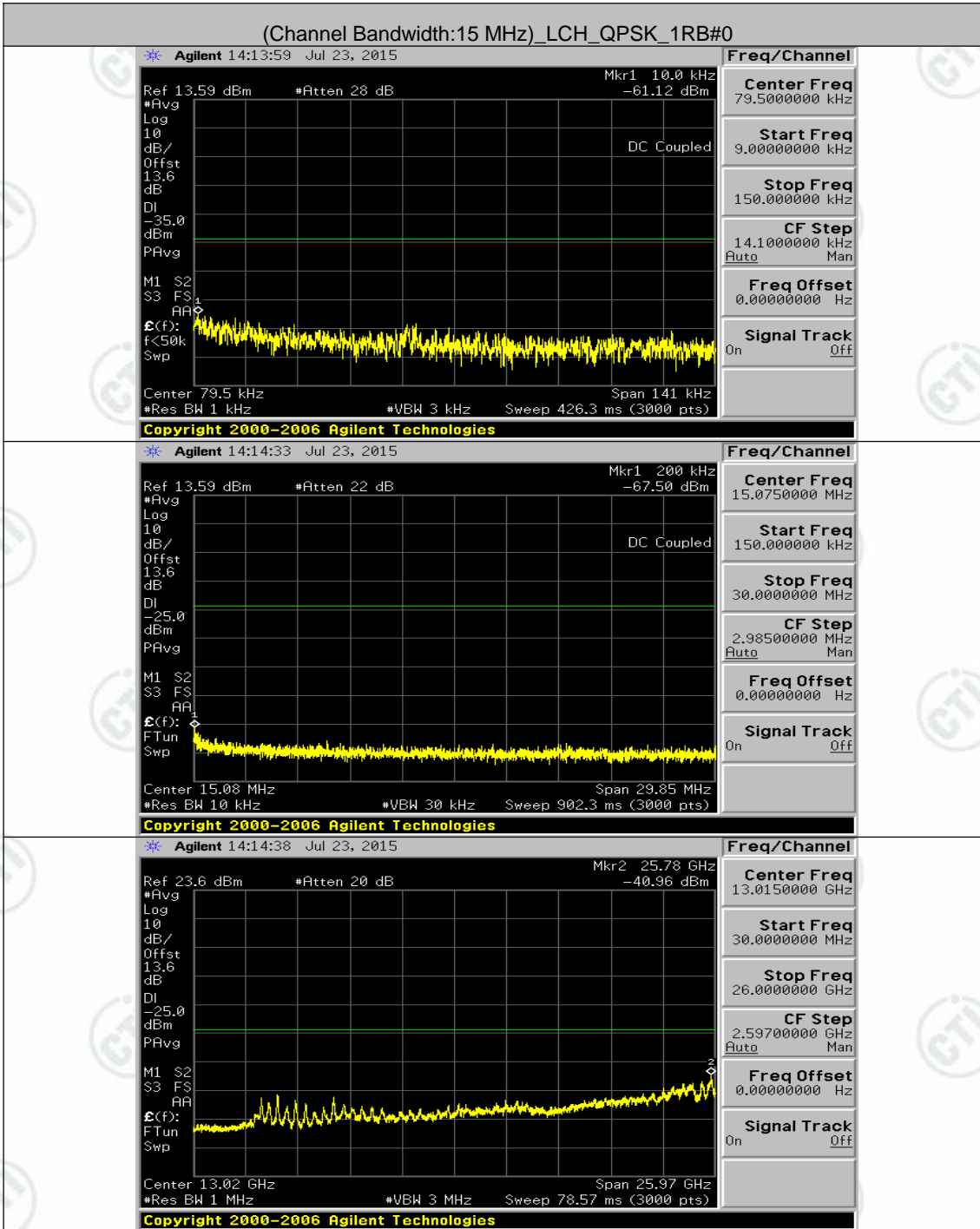

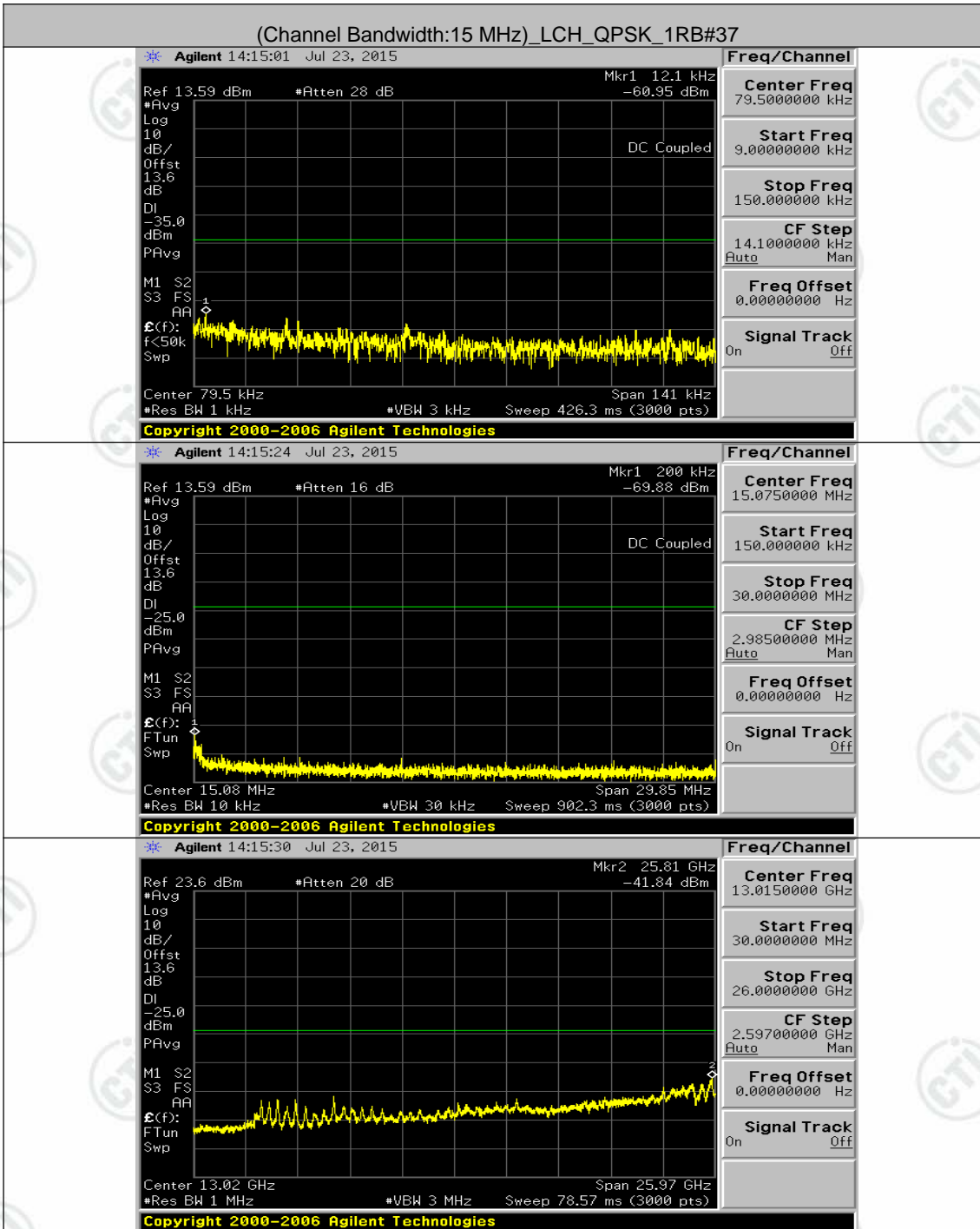

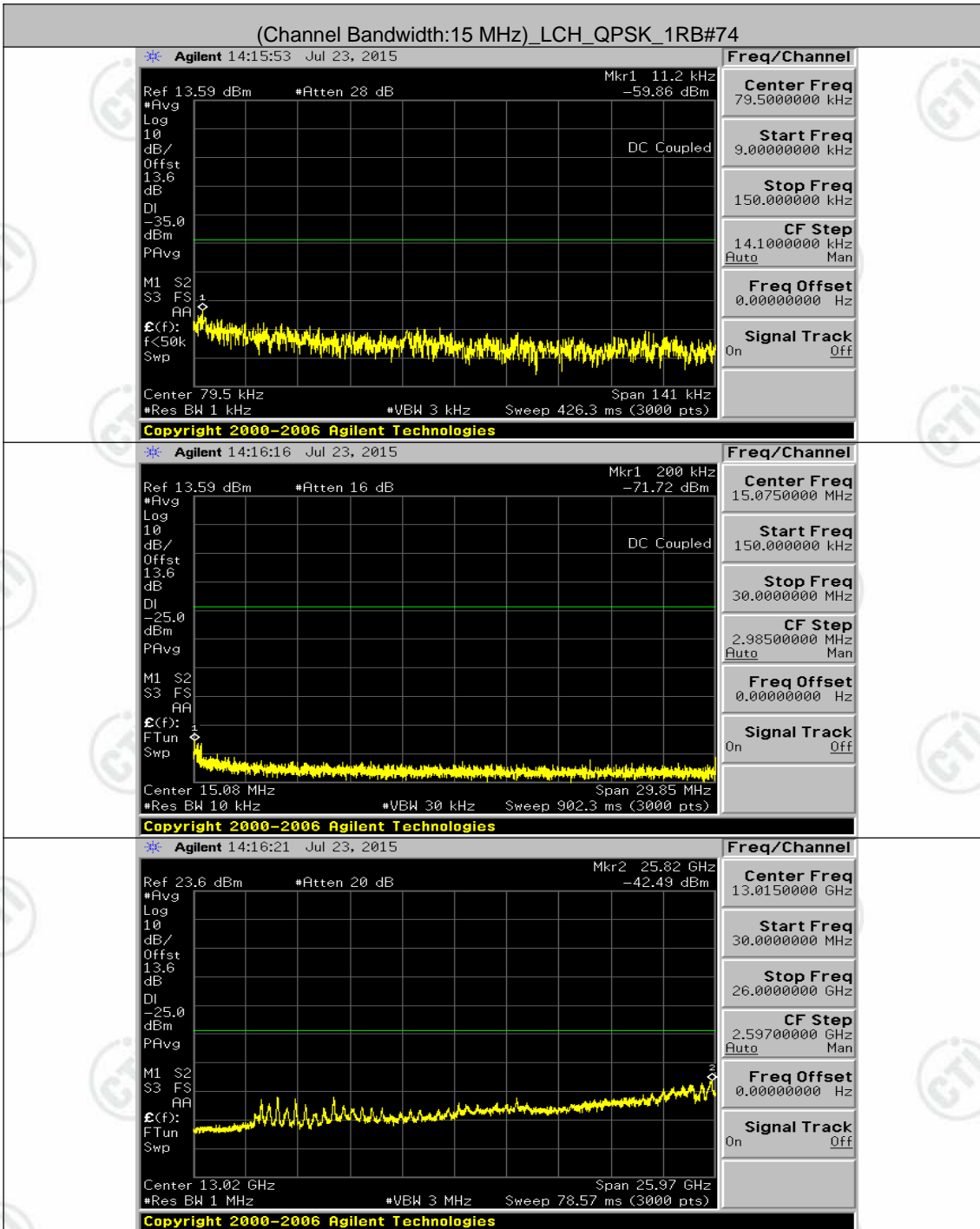

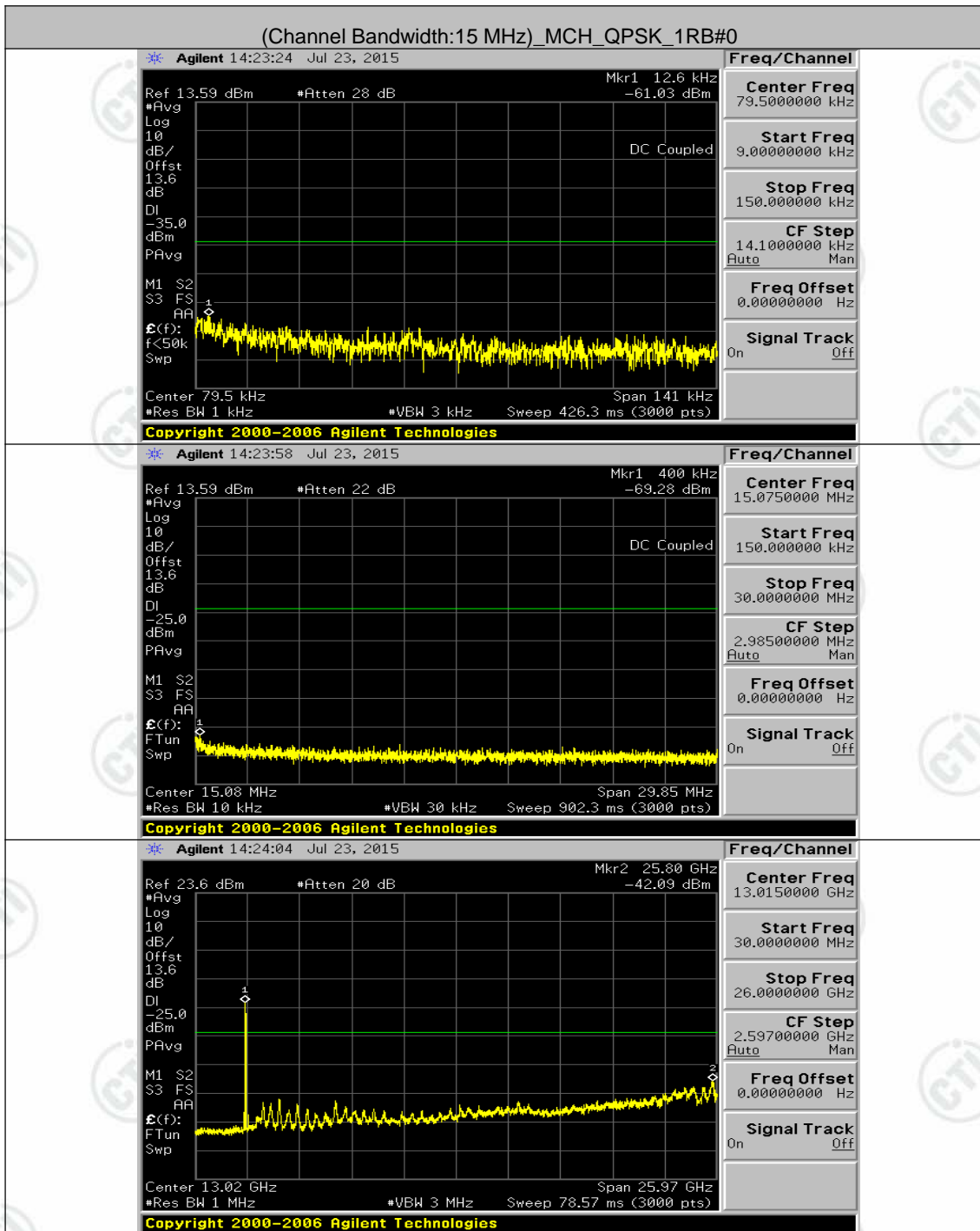

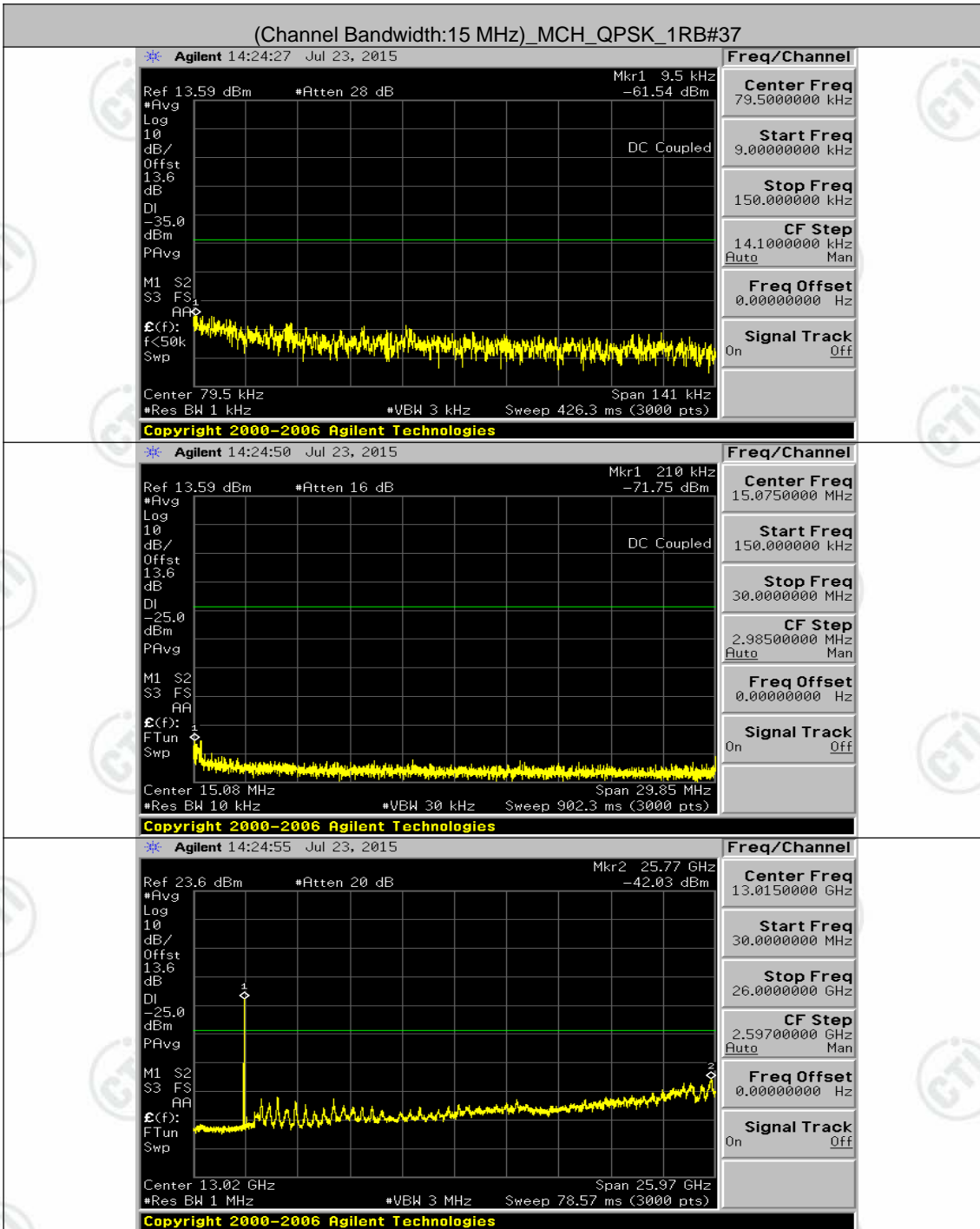

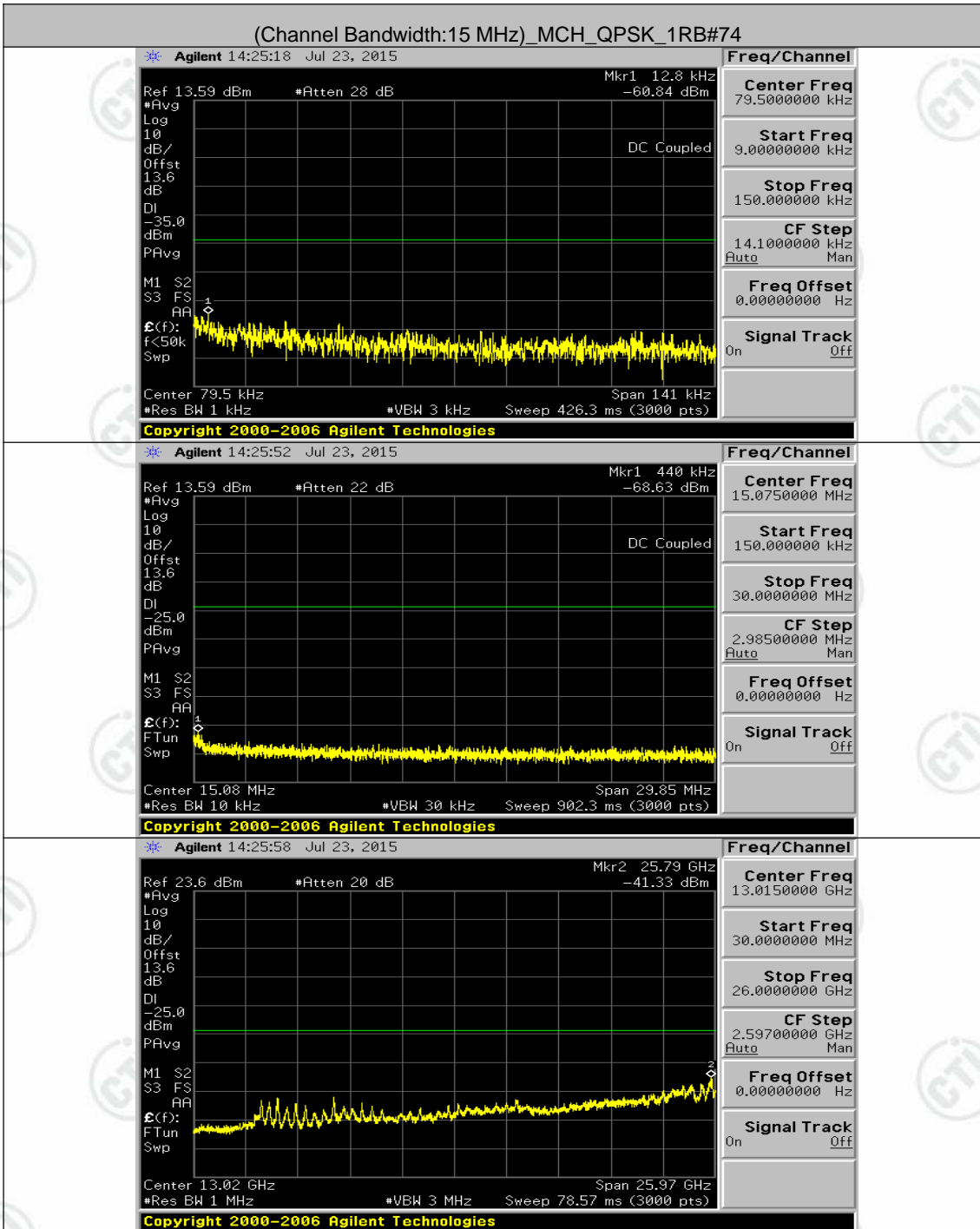

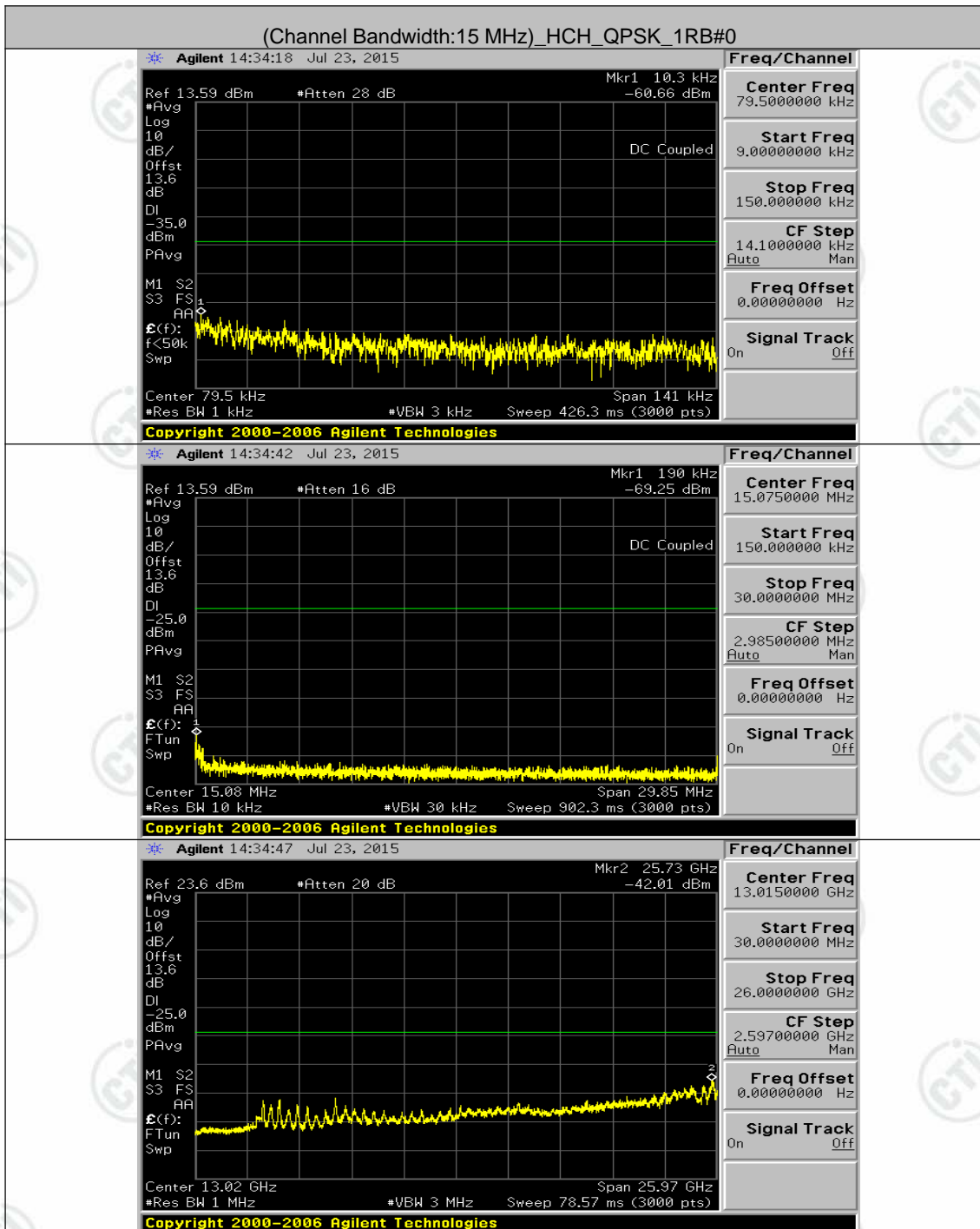

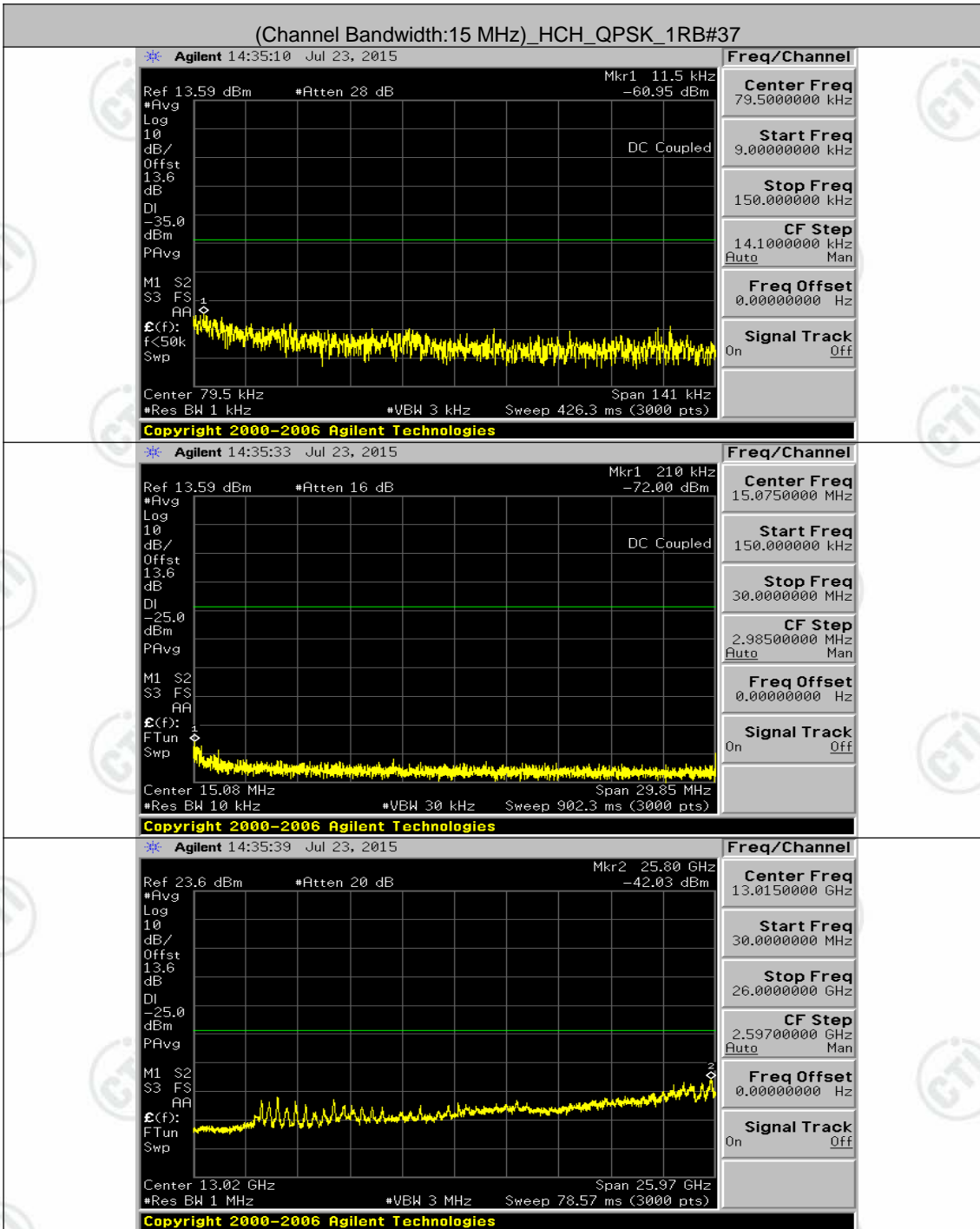

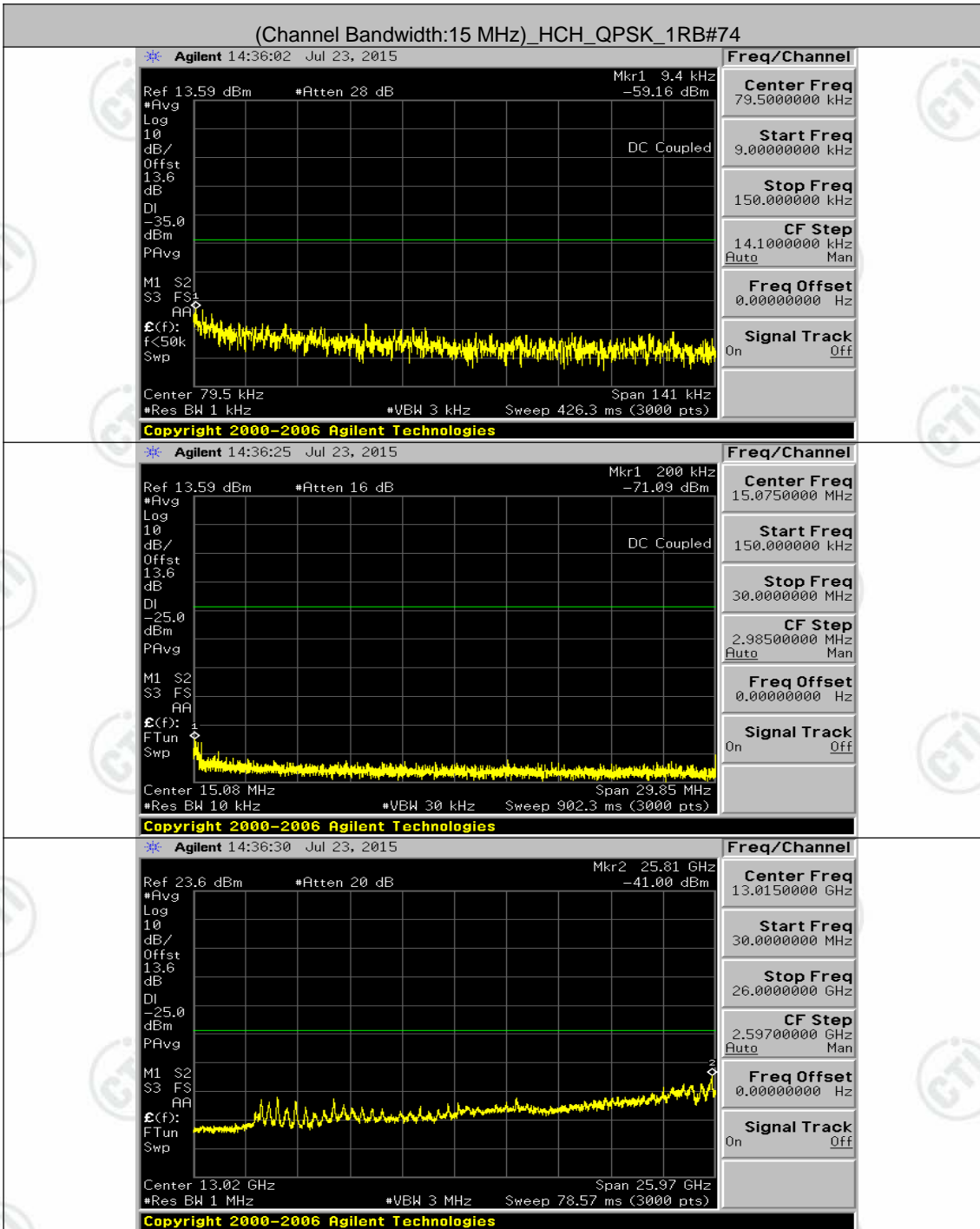

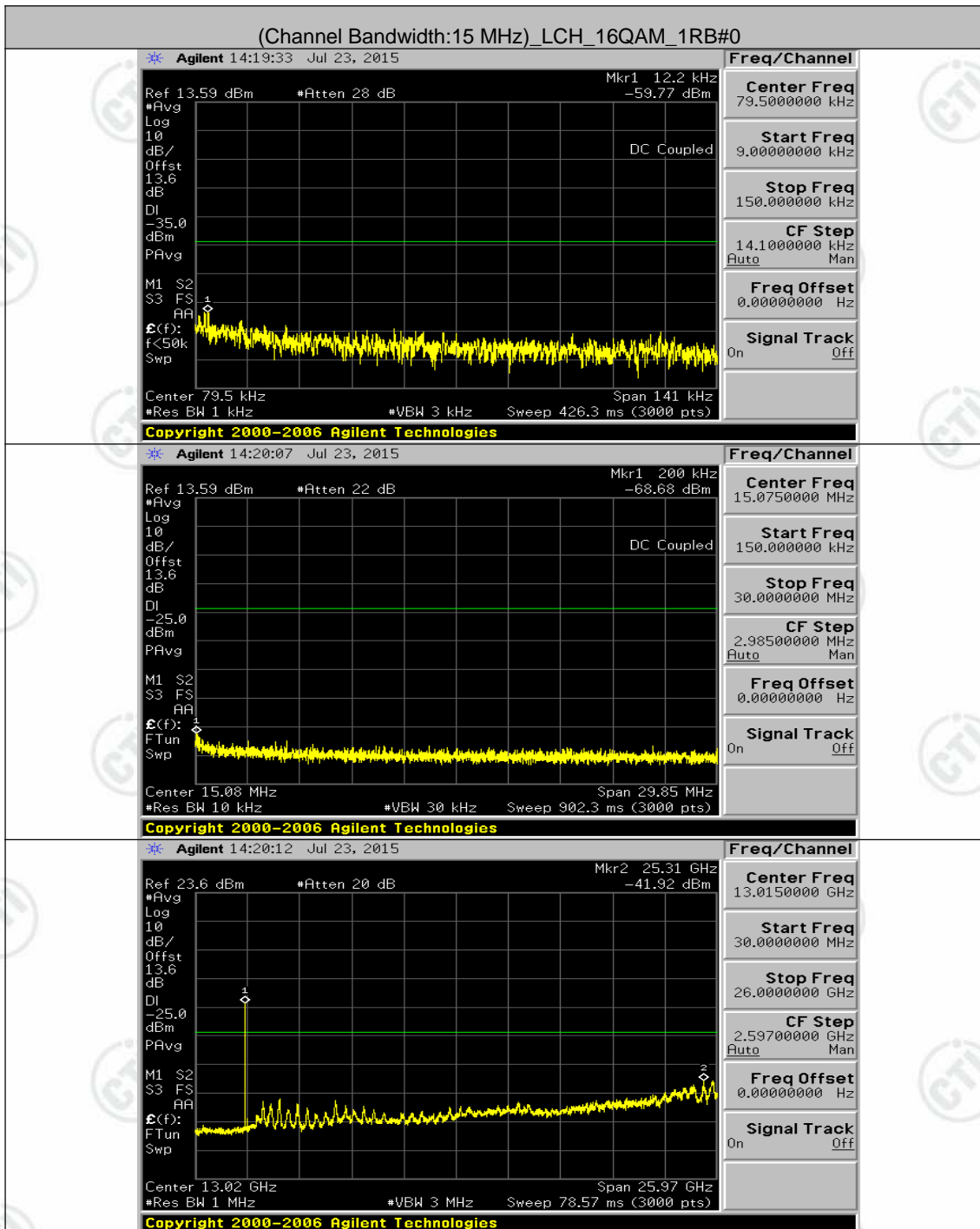

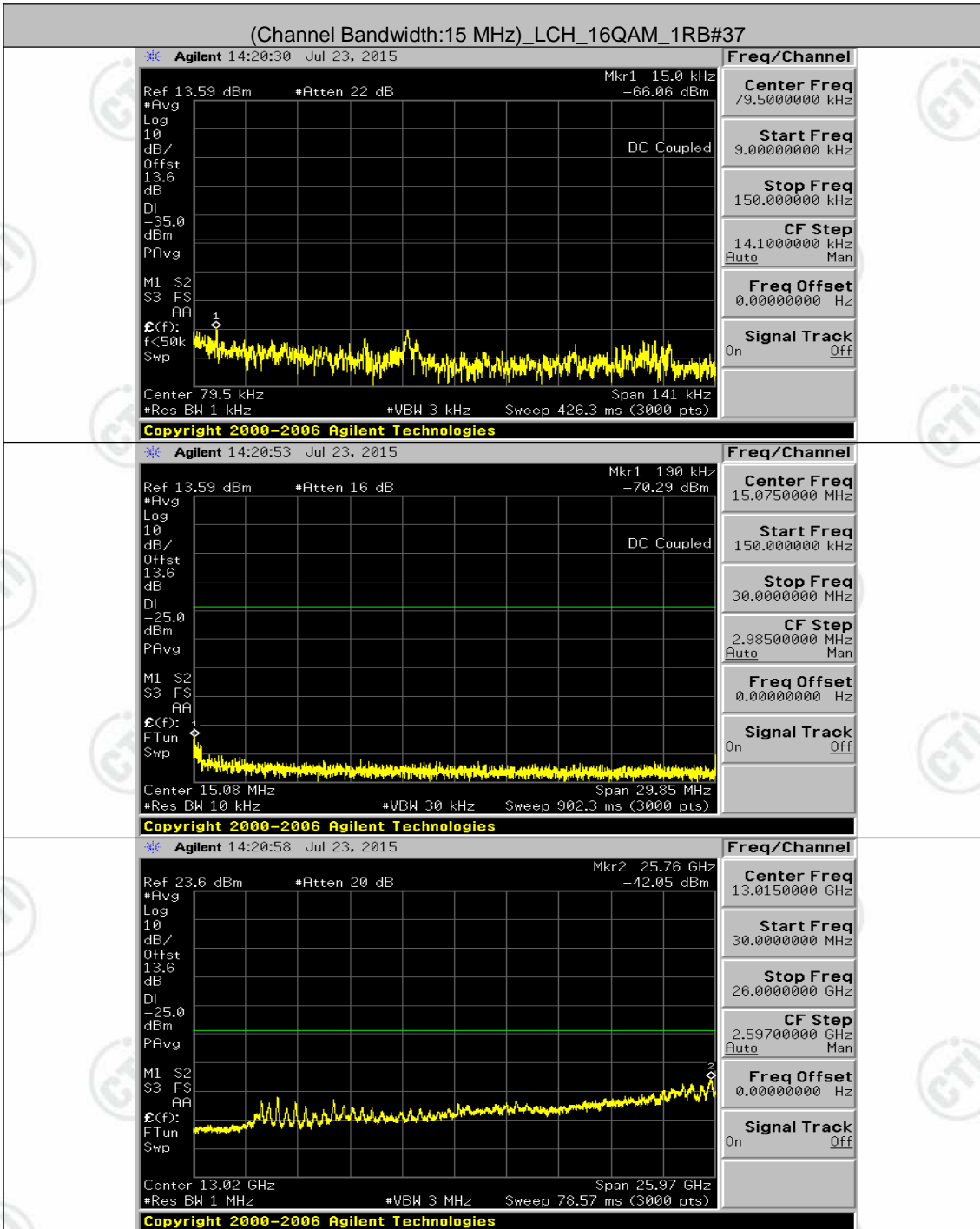

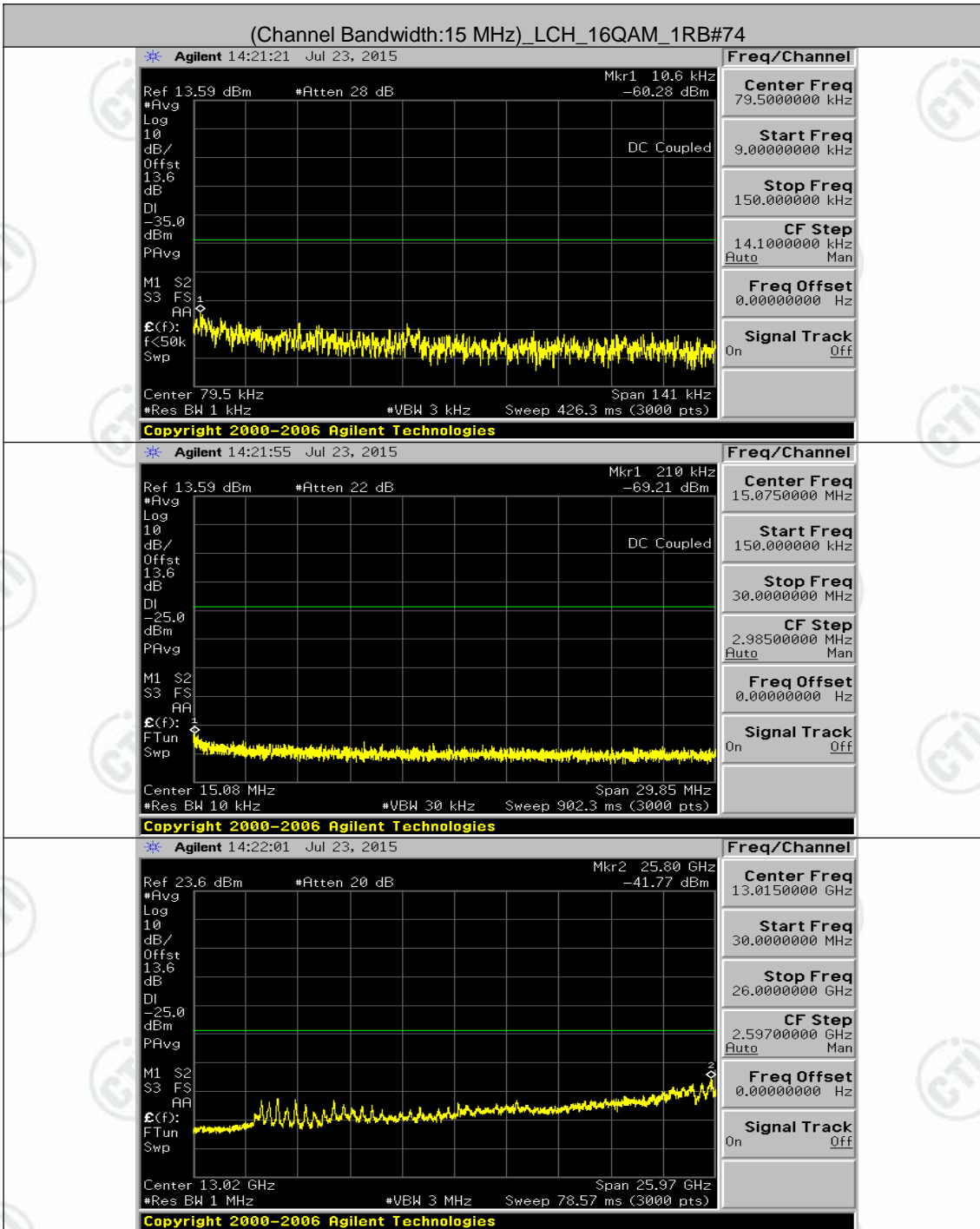

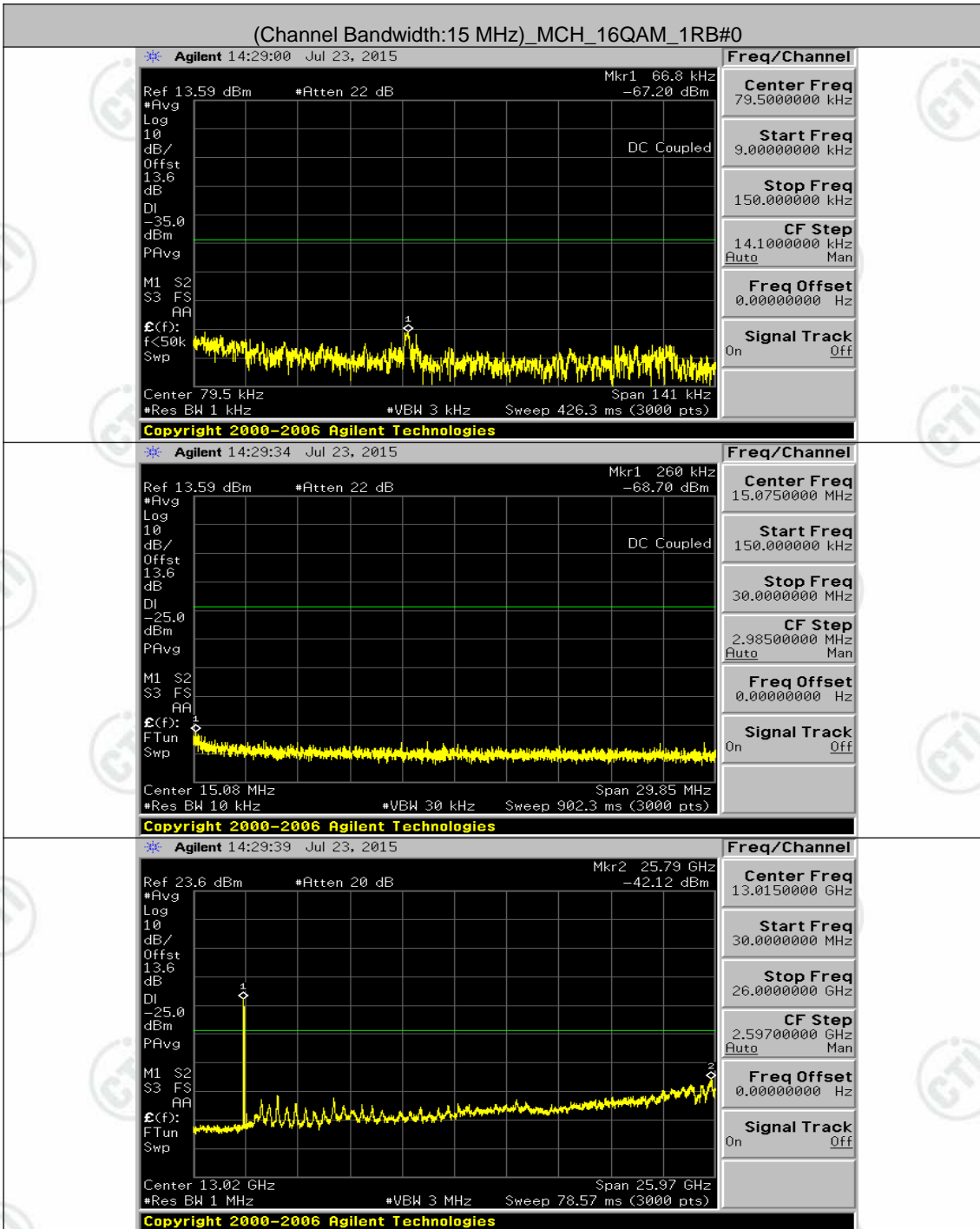

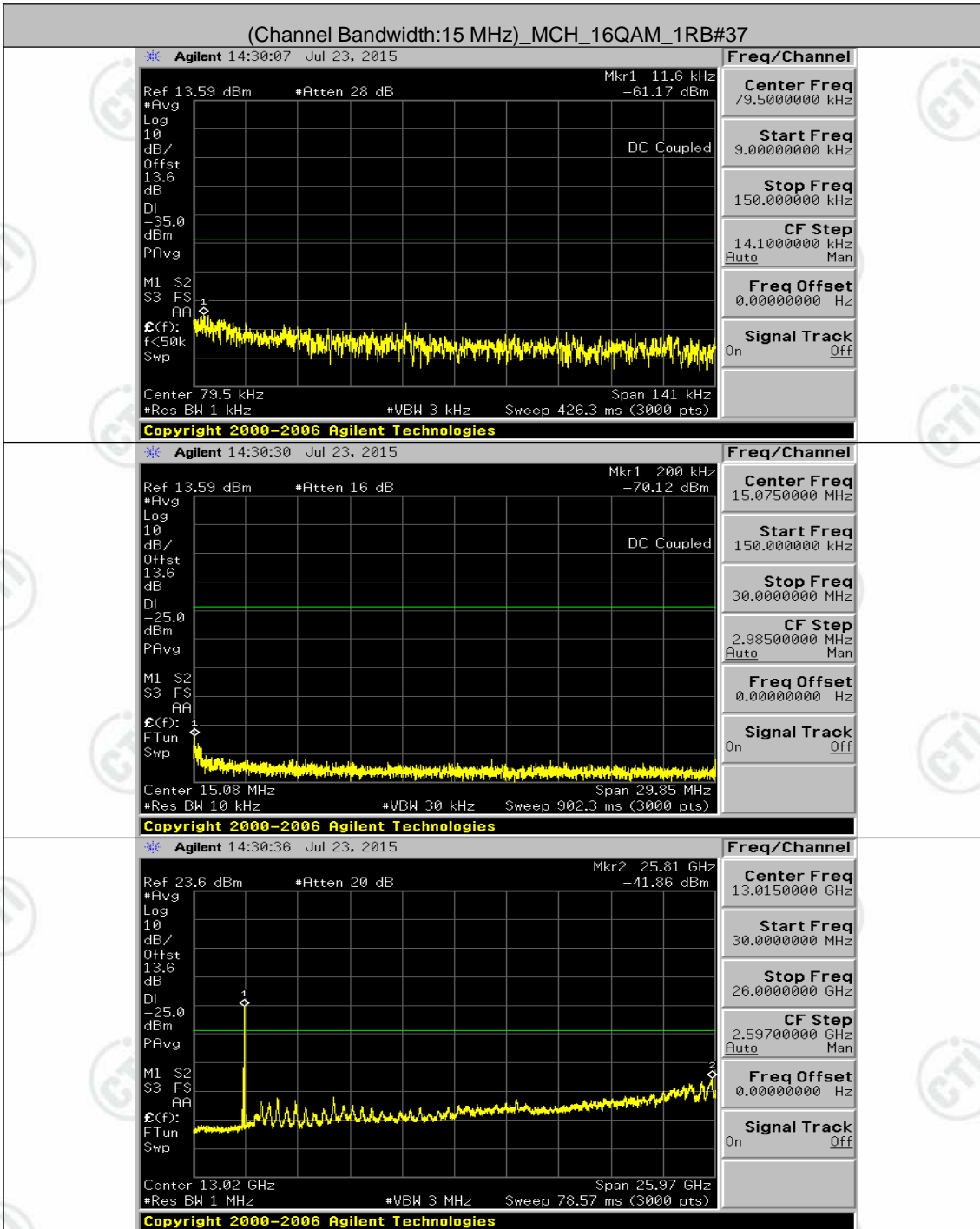

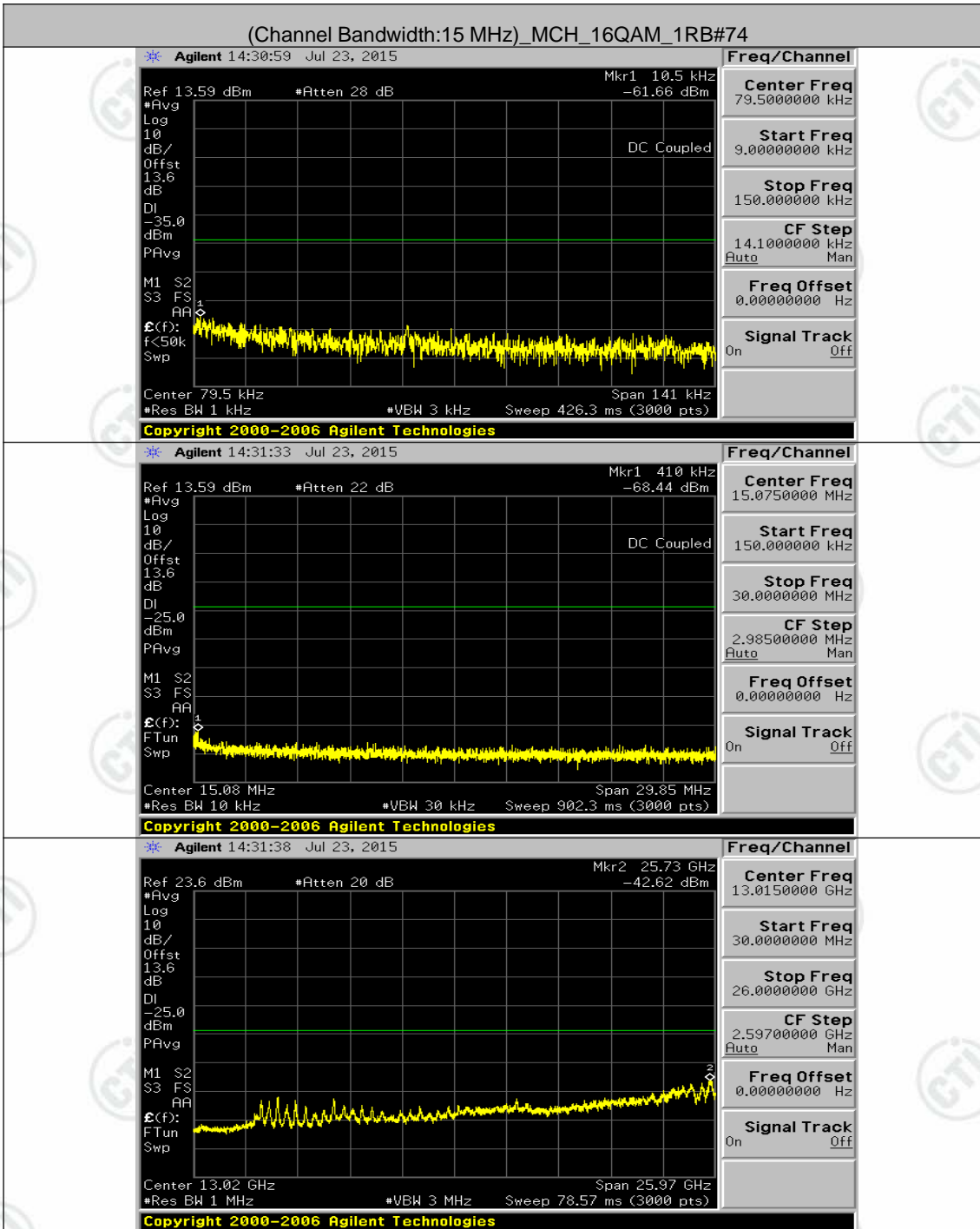

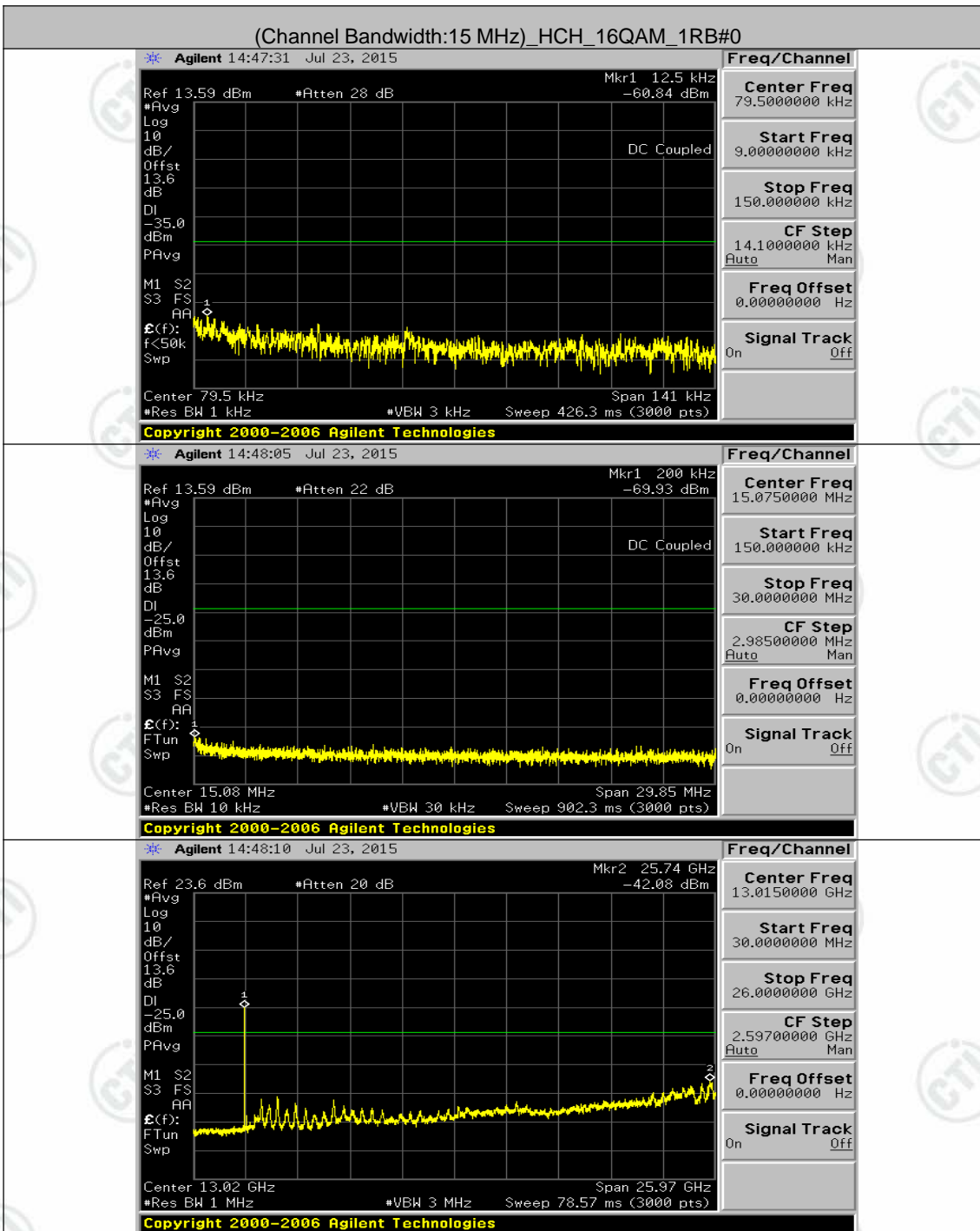

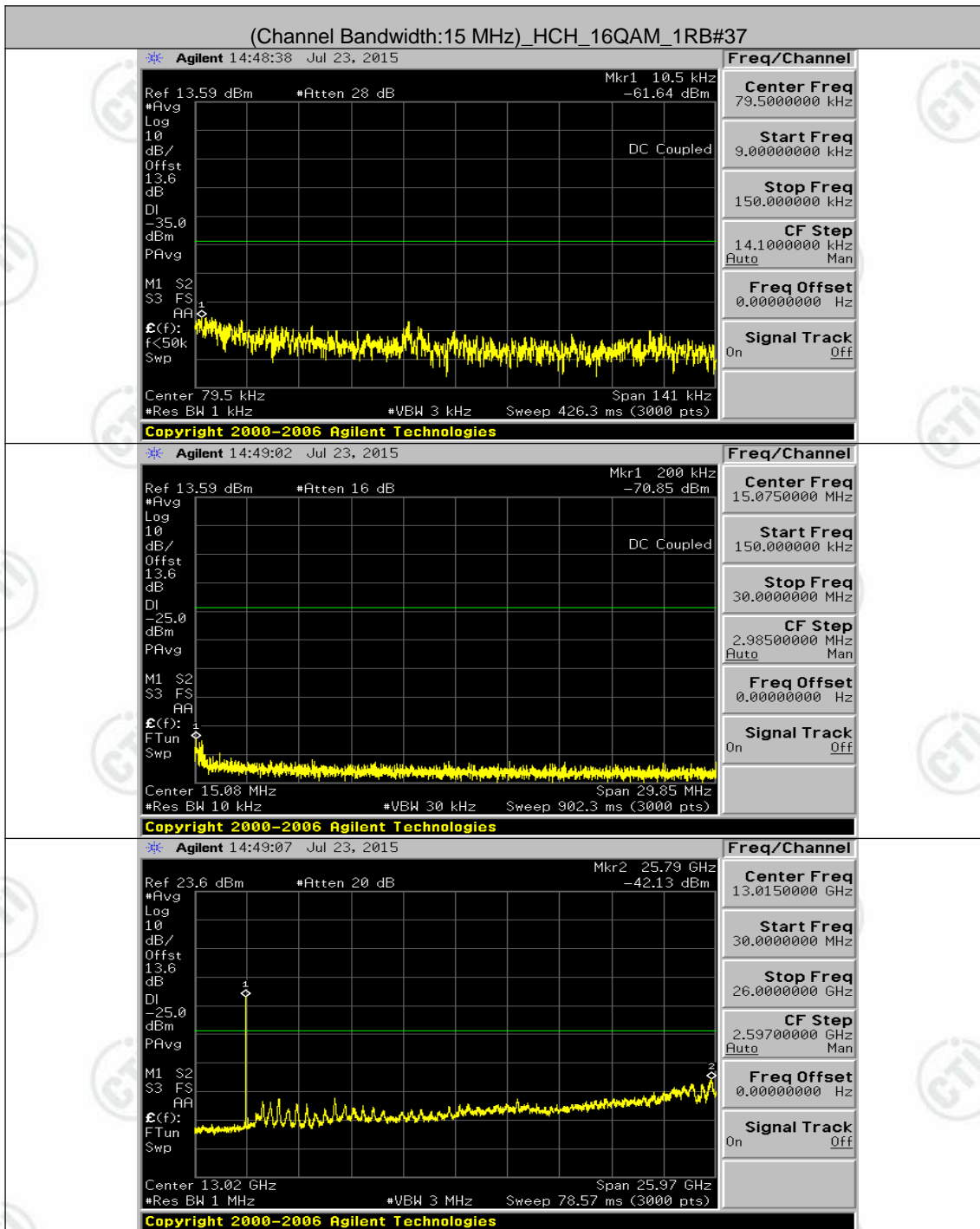

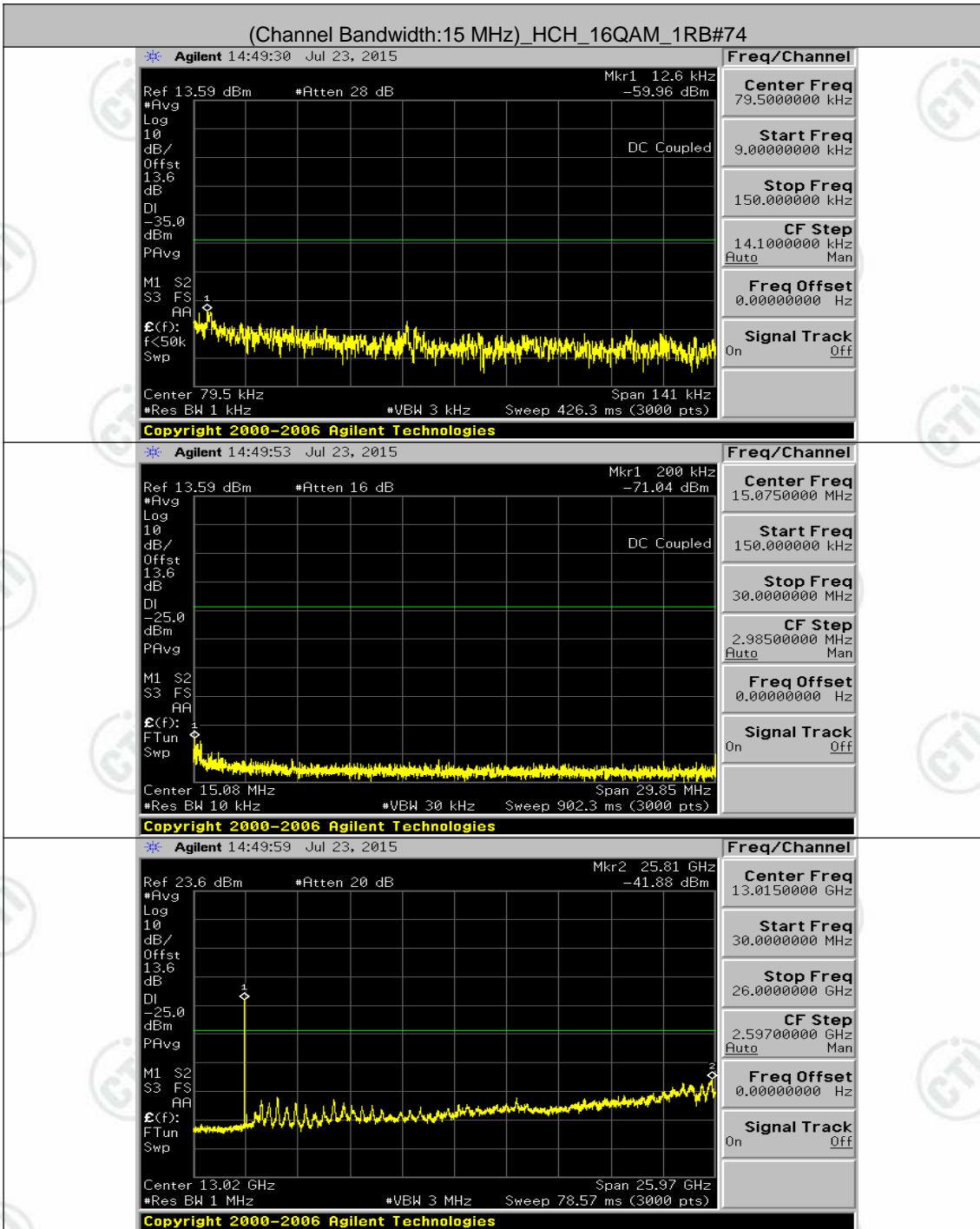

Channel Bandwidth: 20 MHz

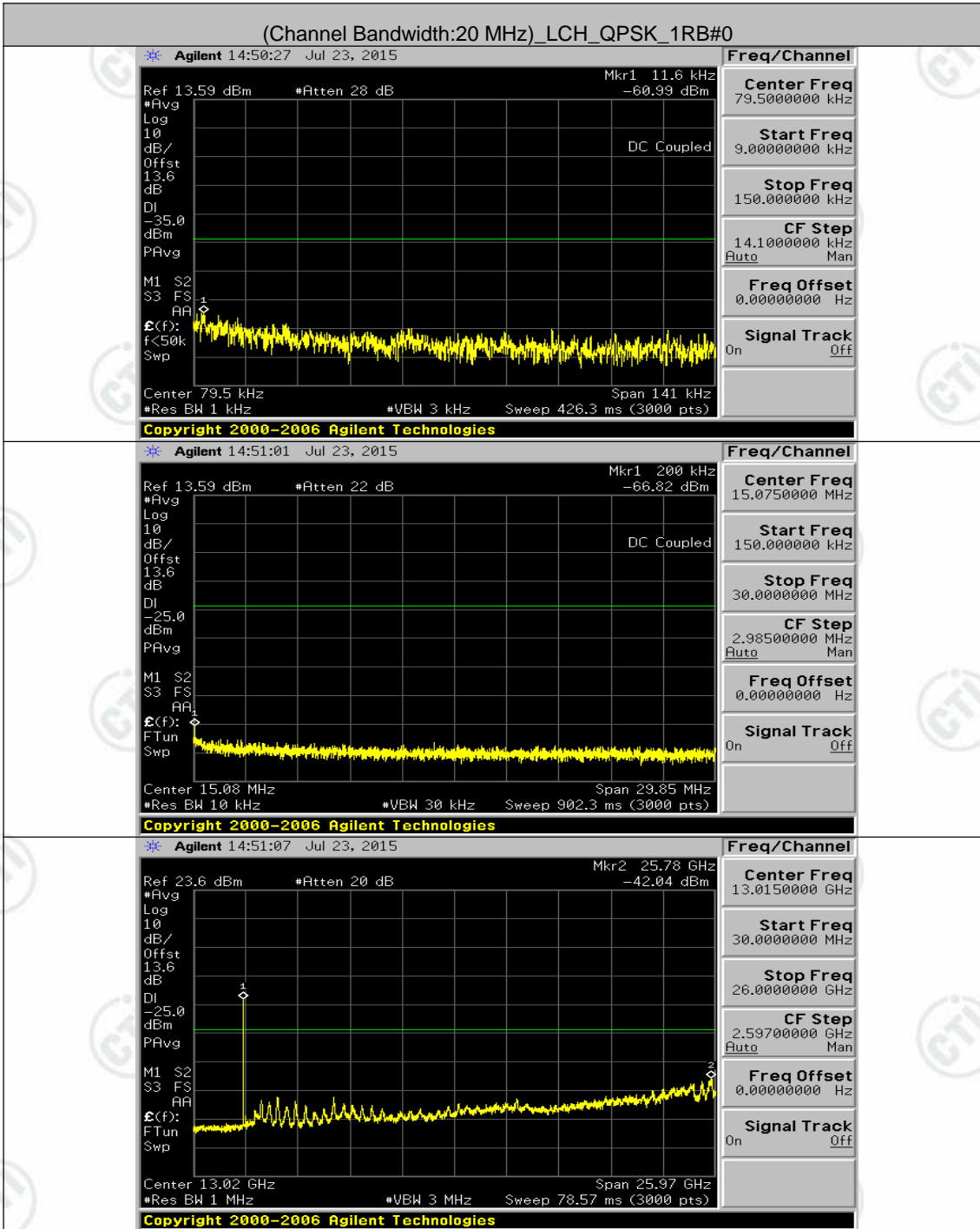

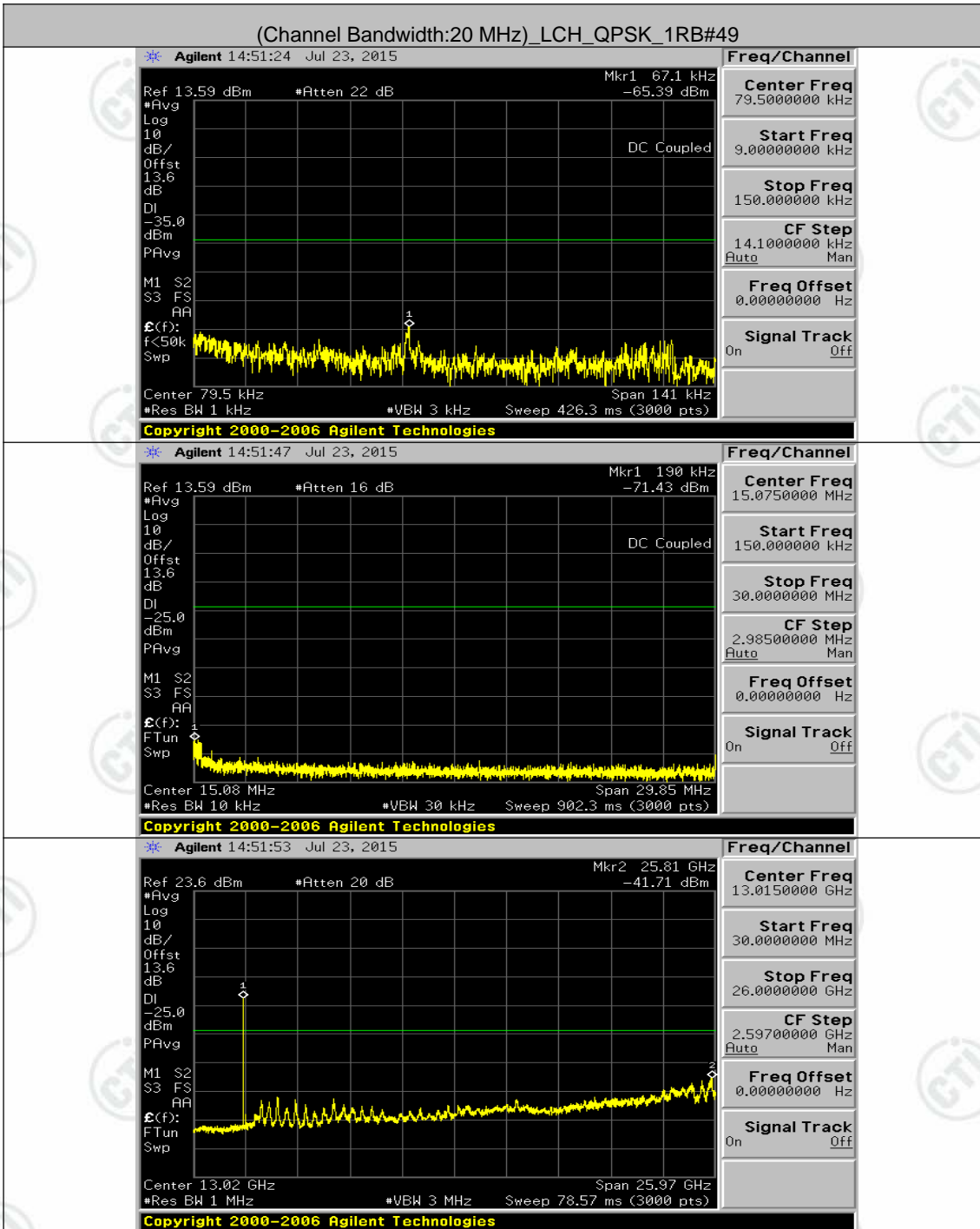

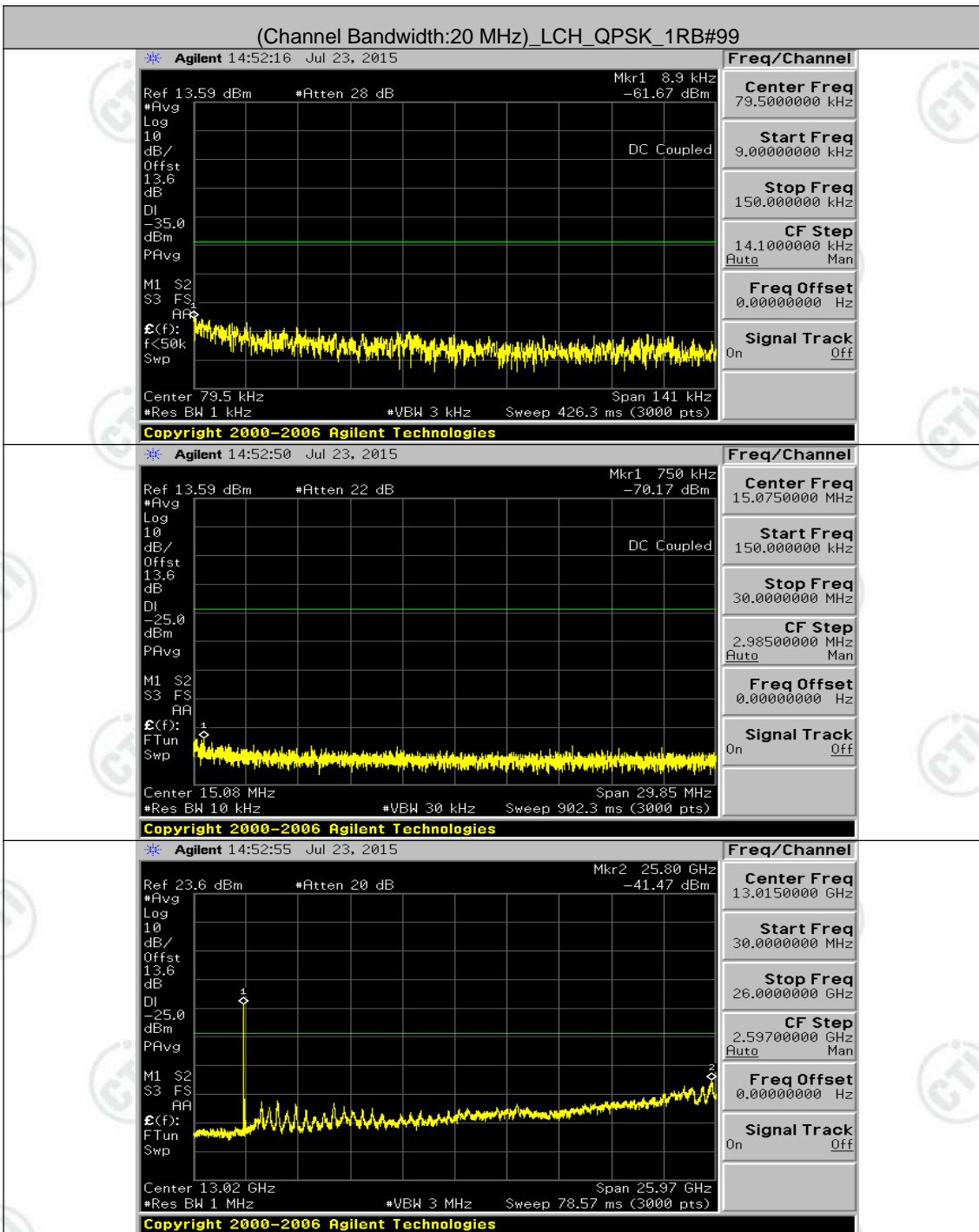

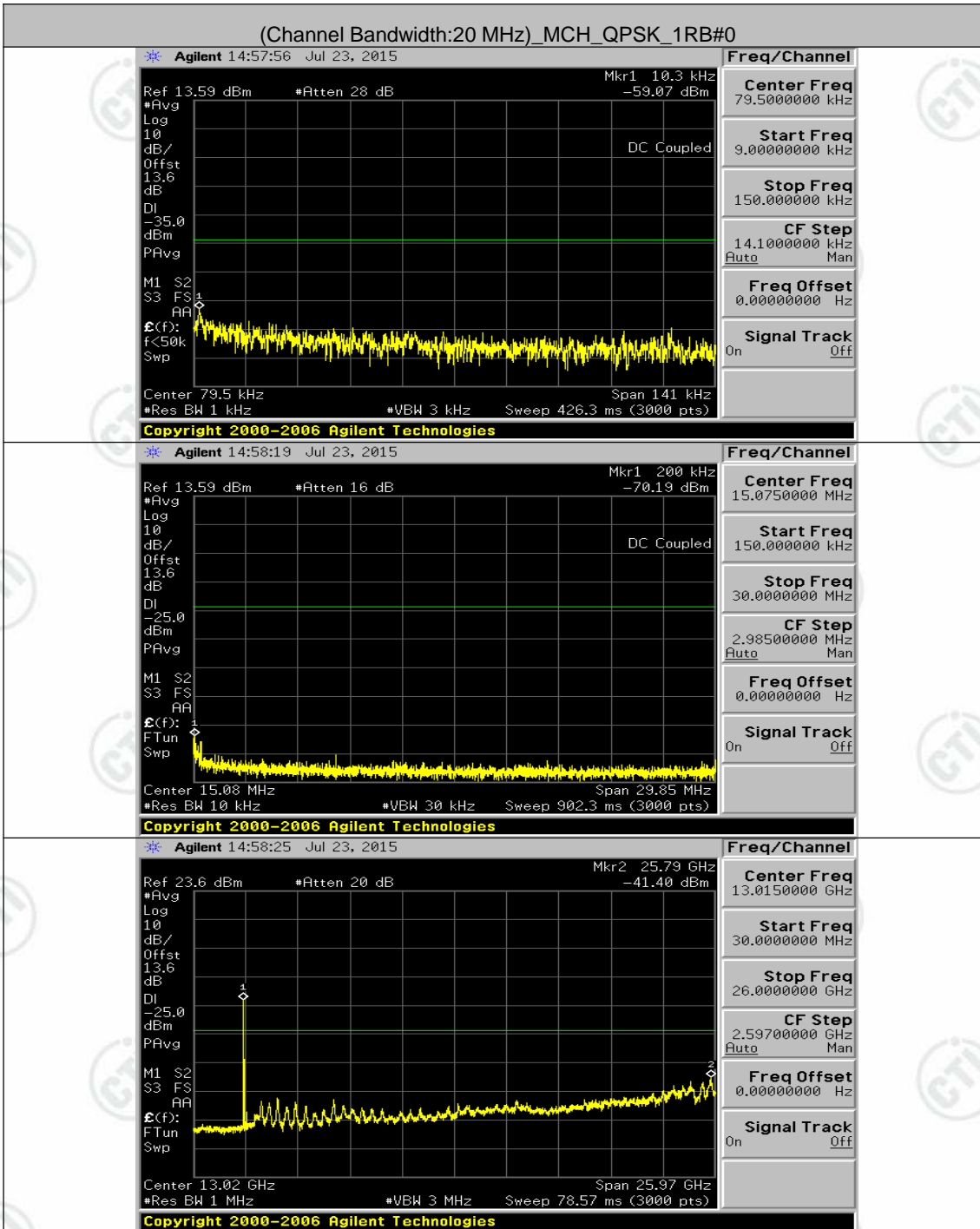

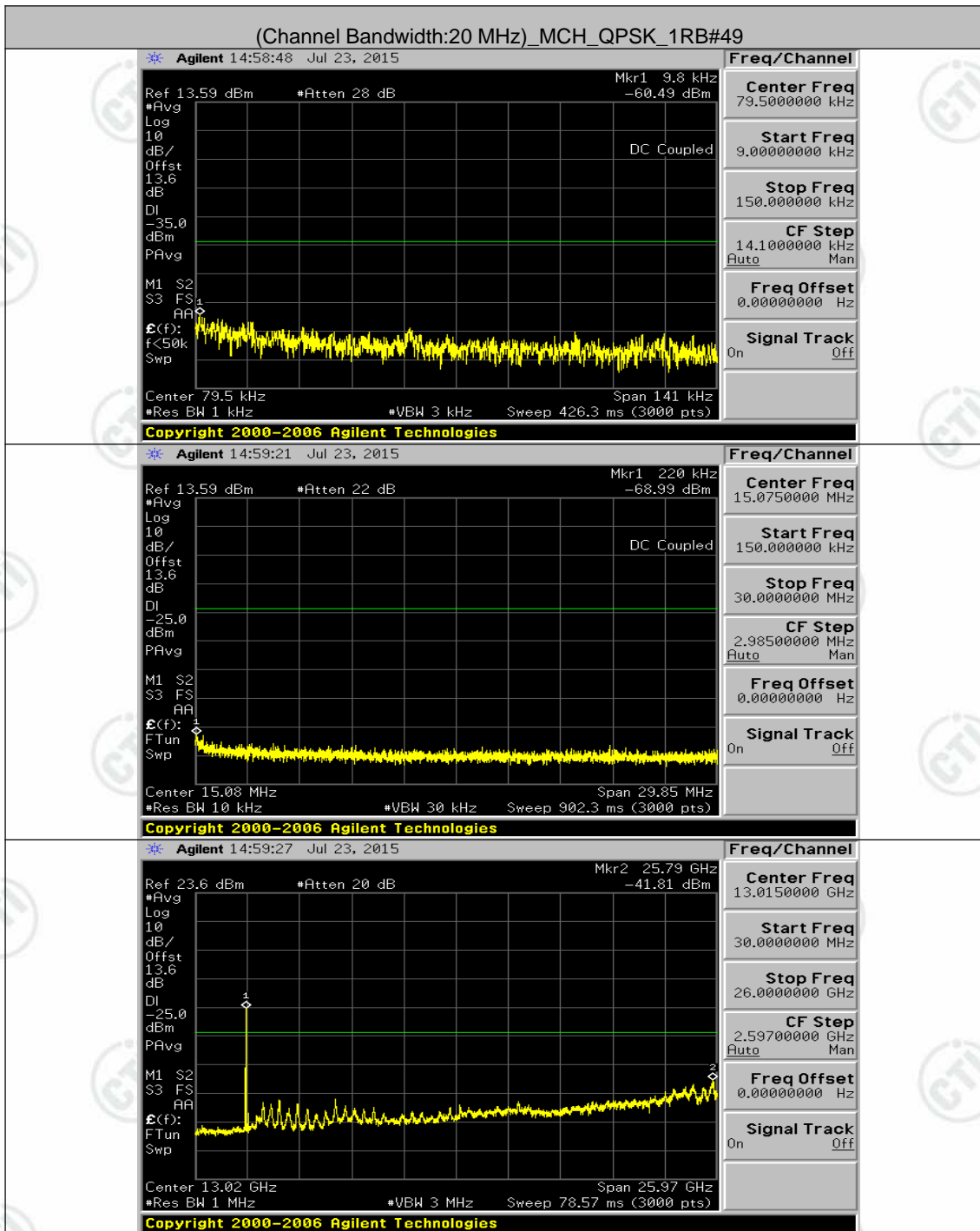

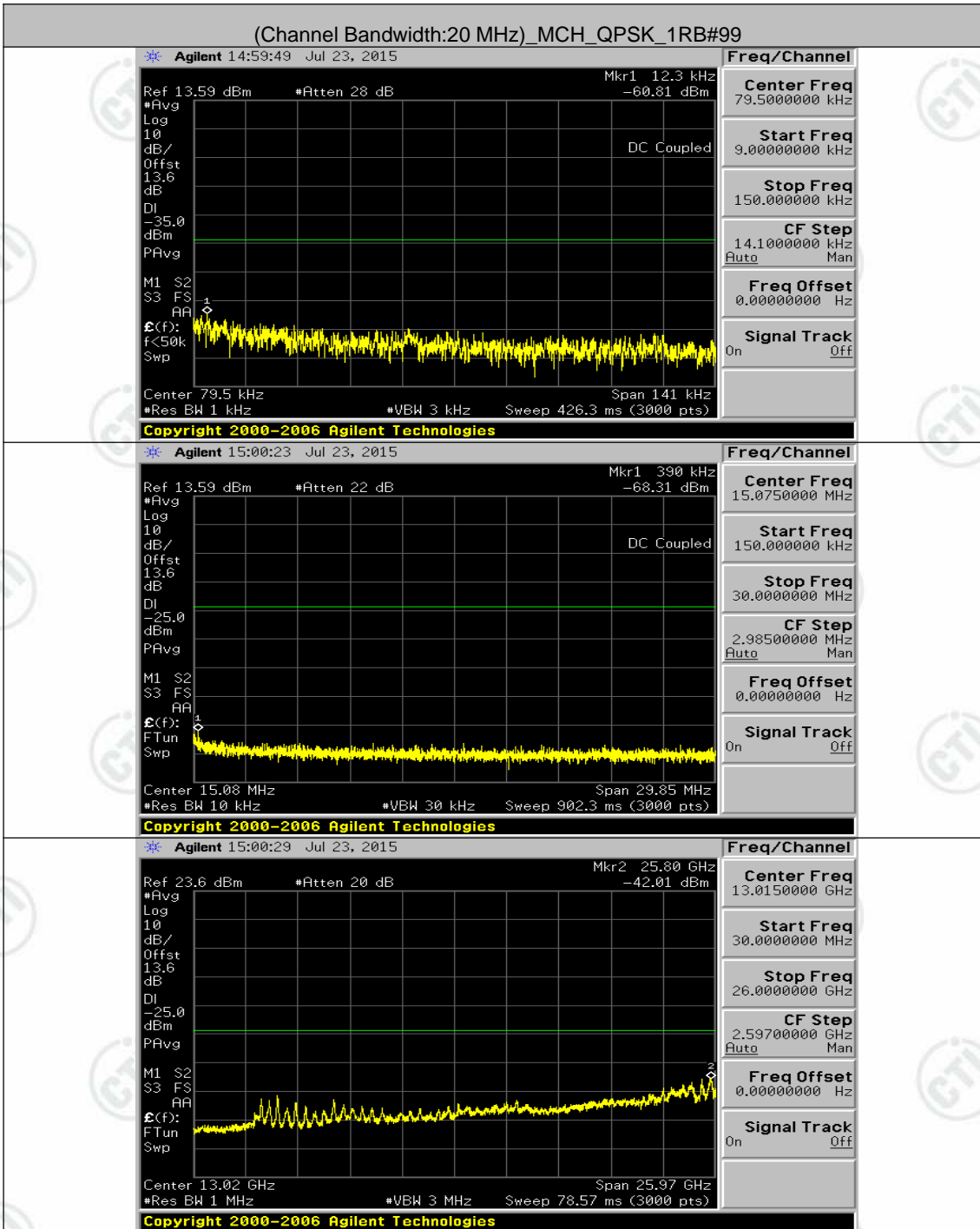

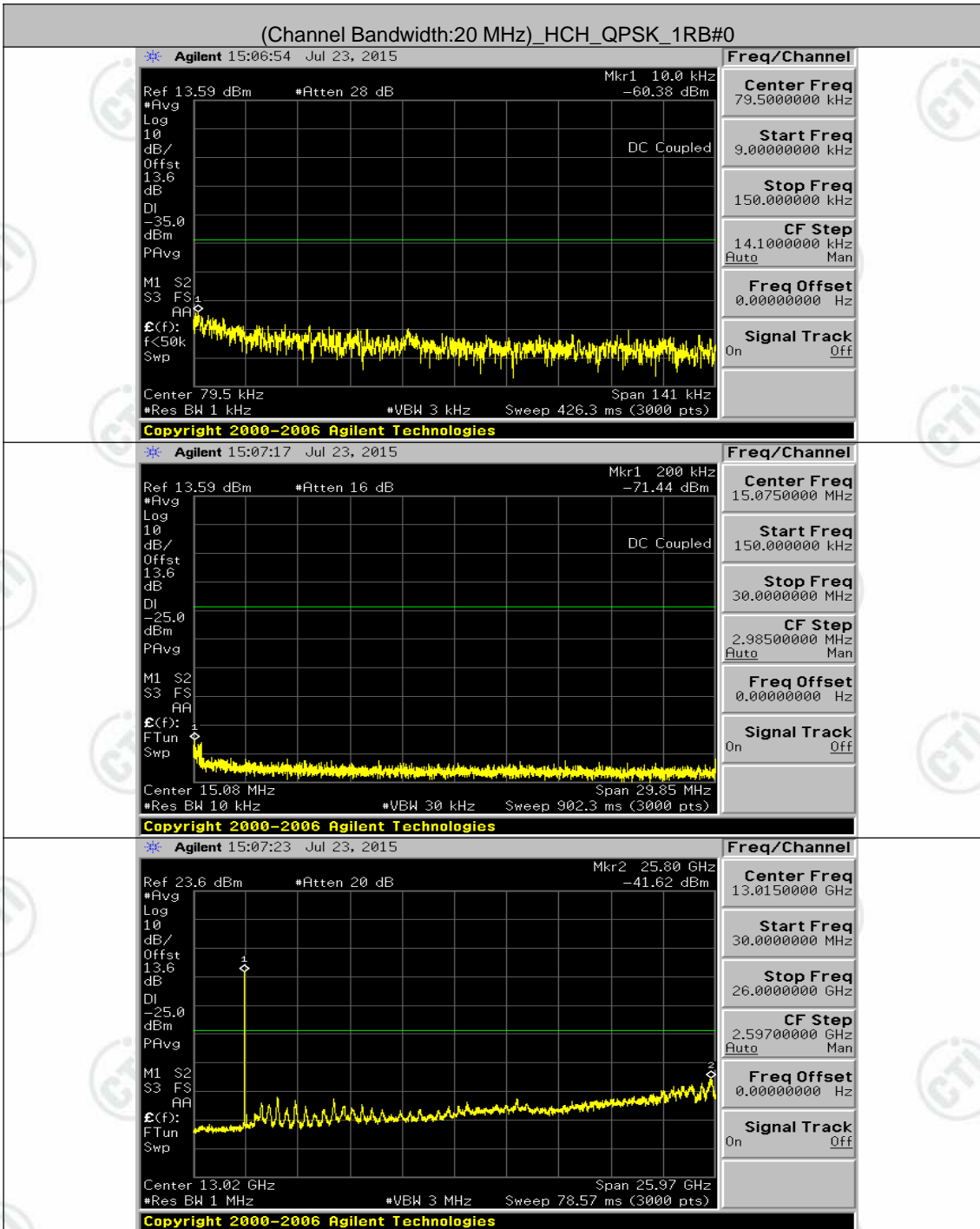

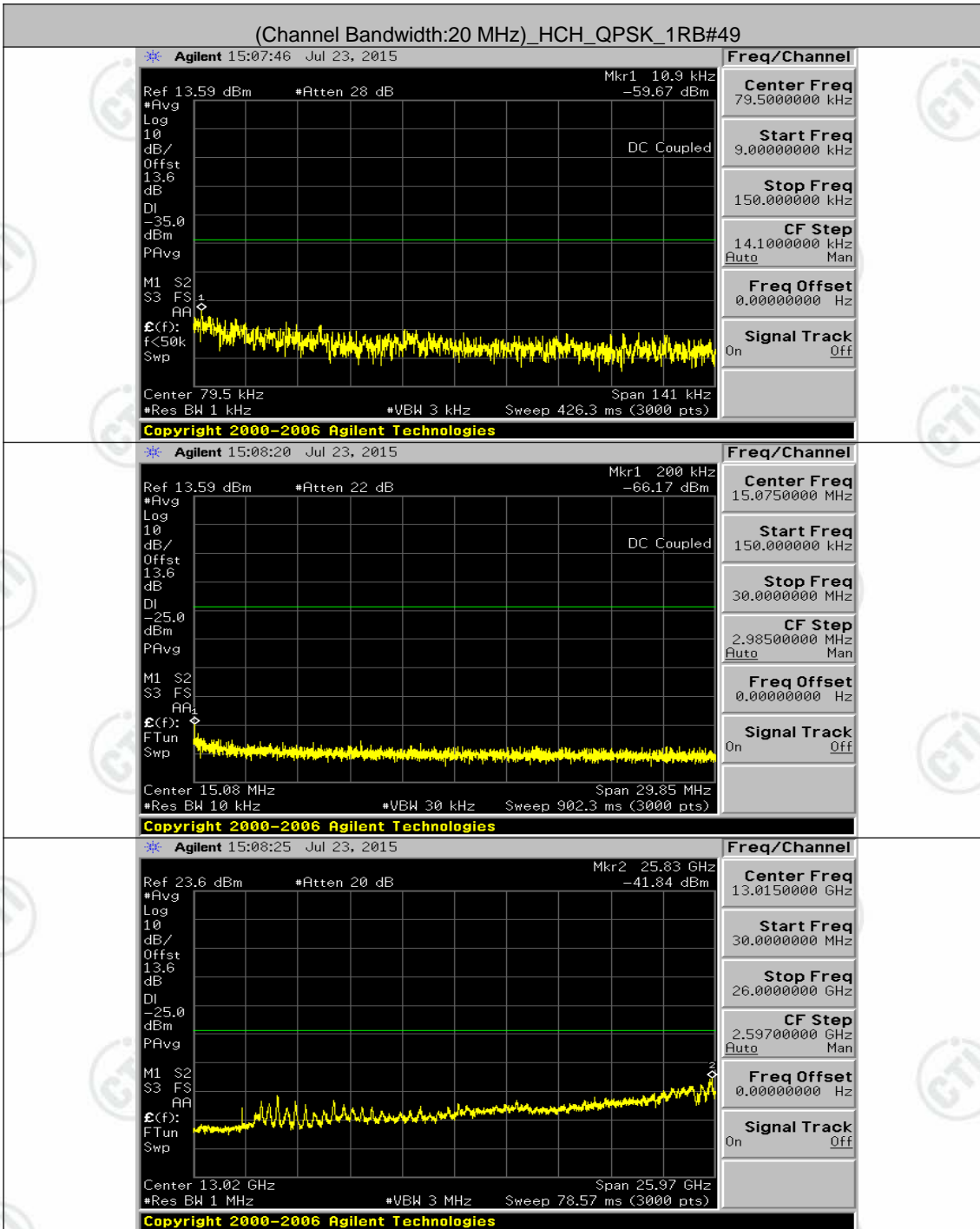

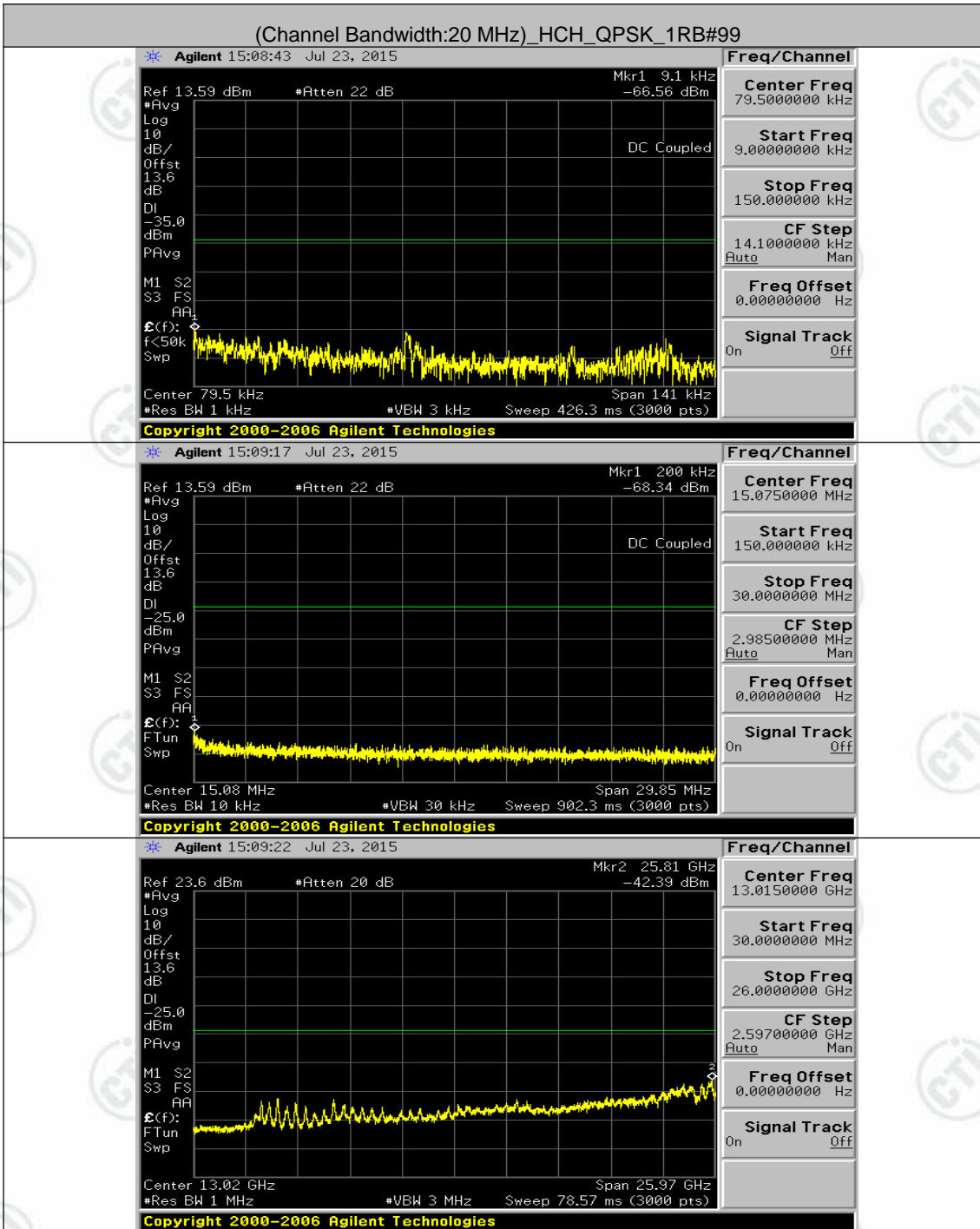

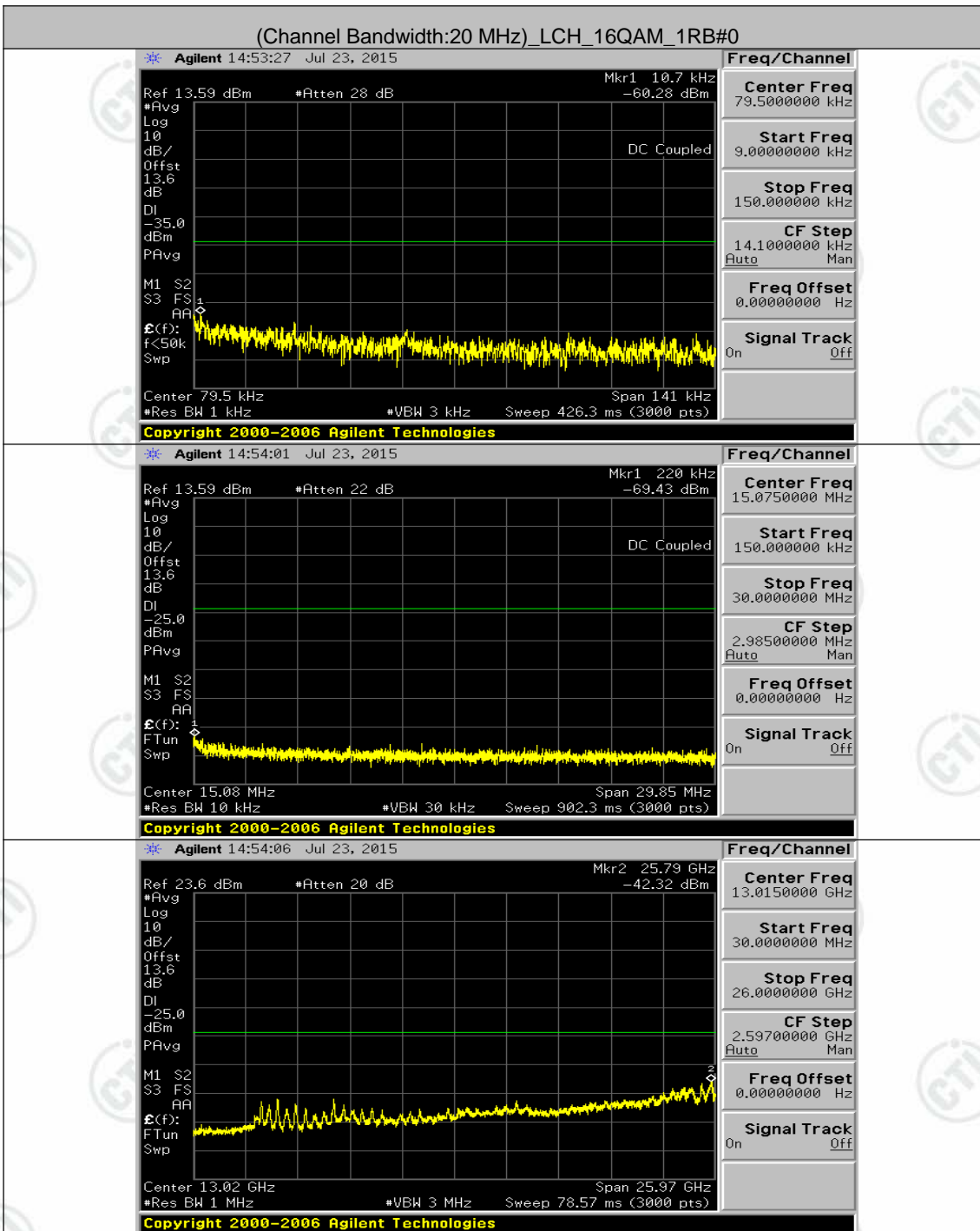

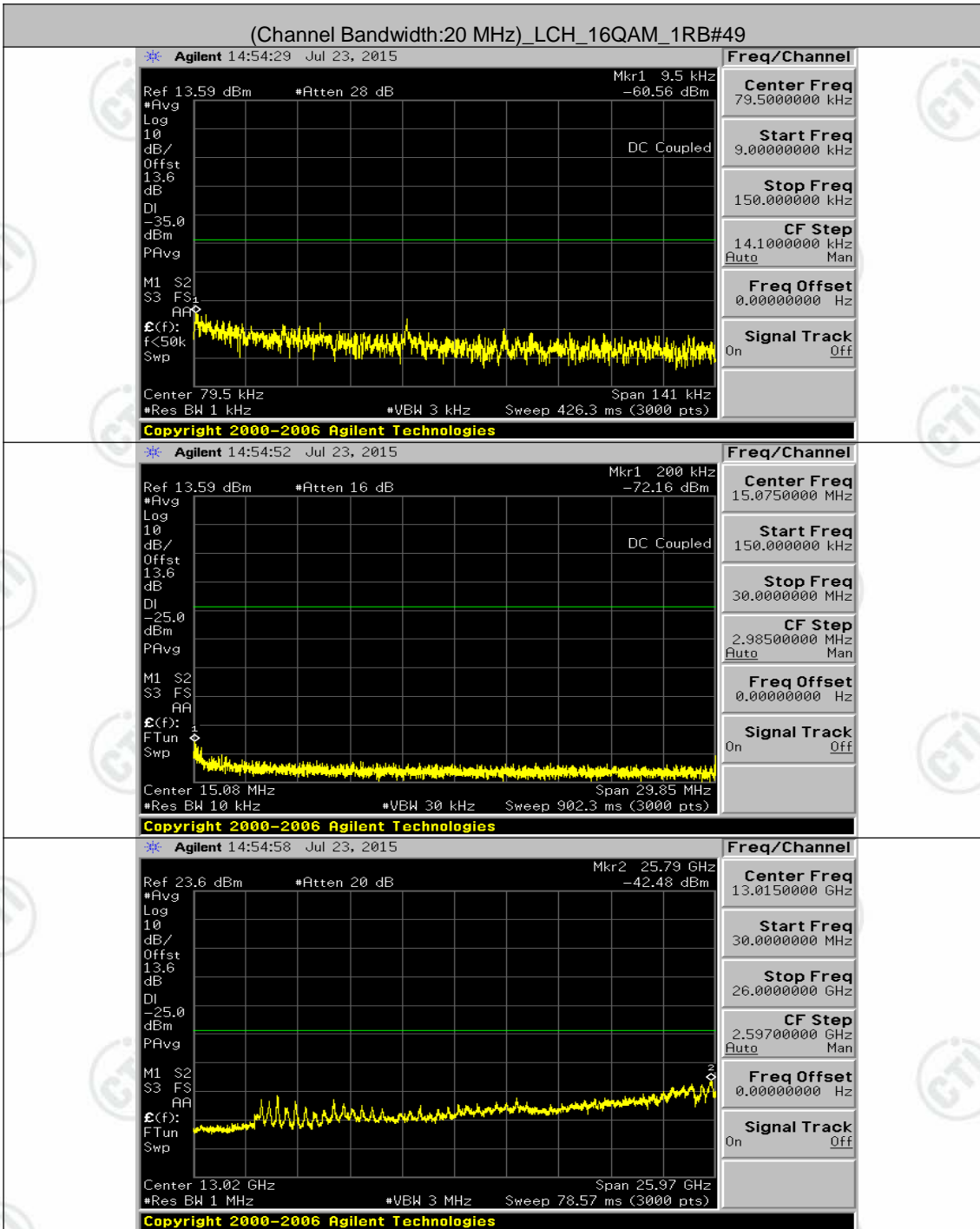

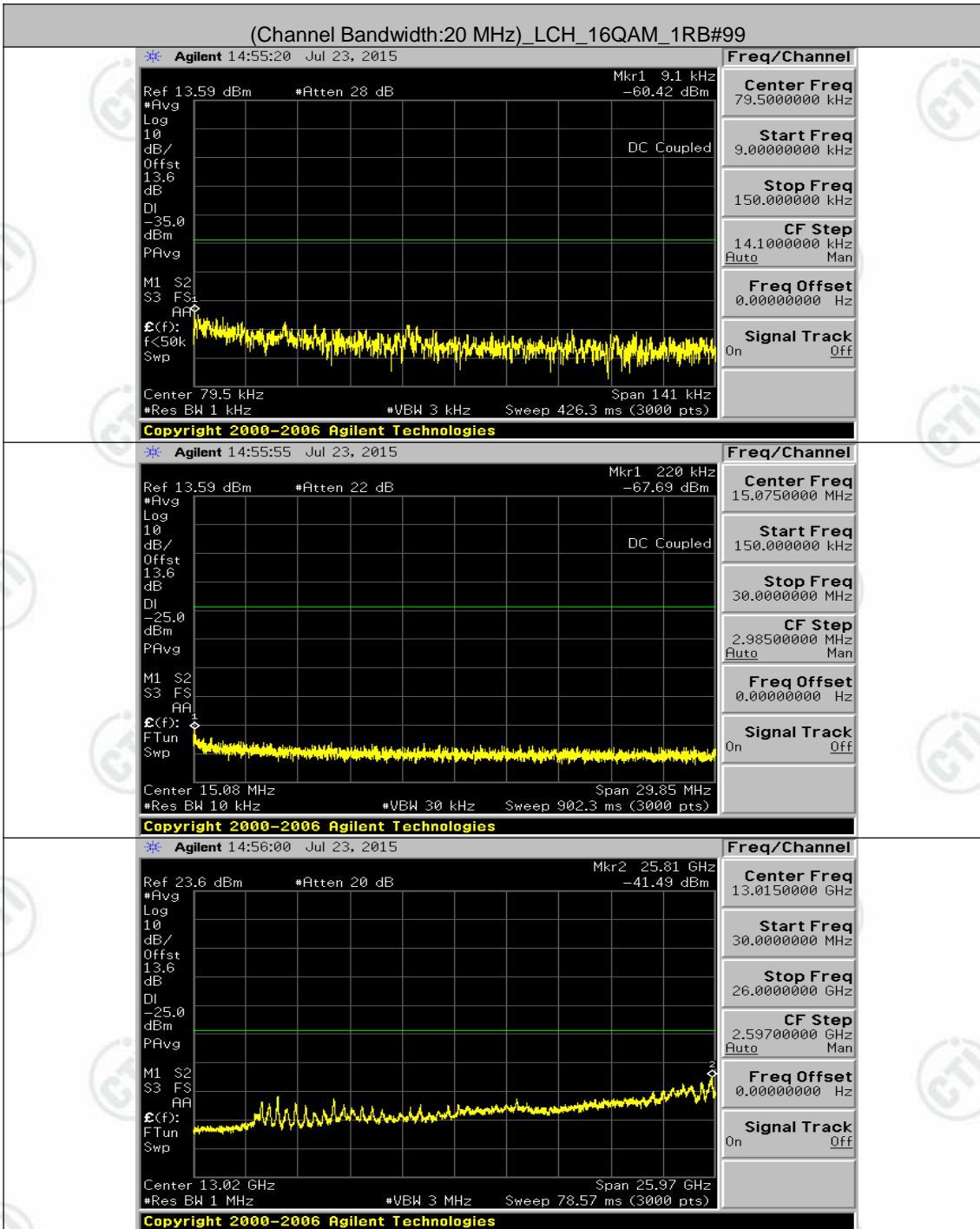

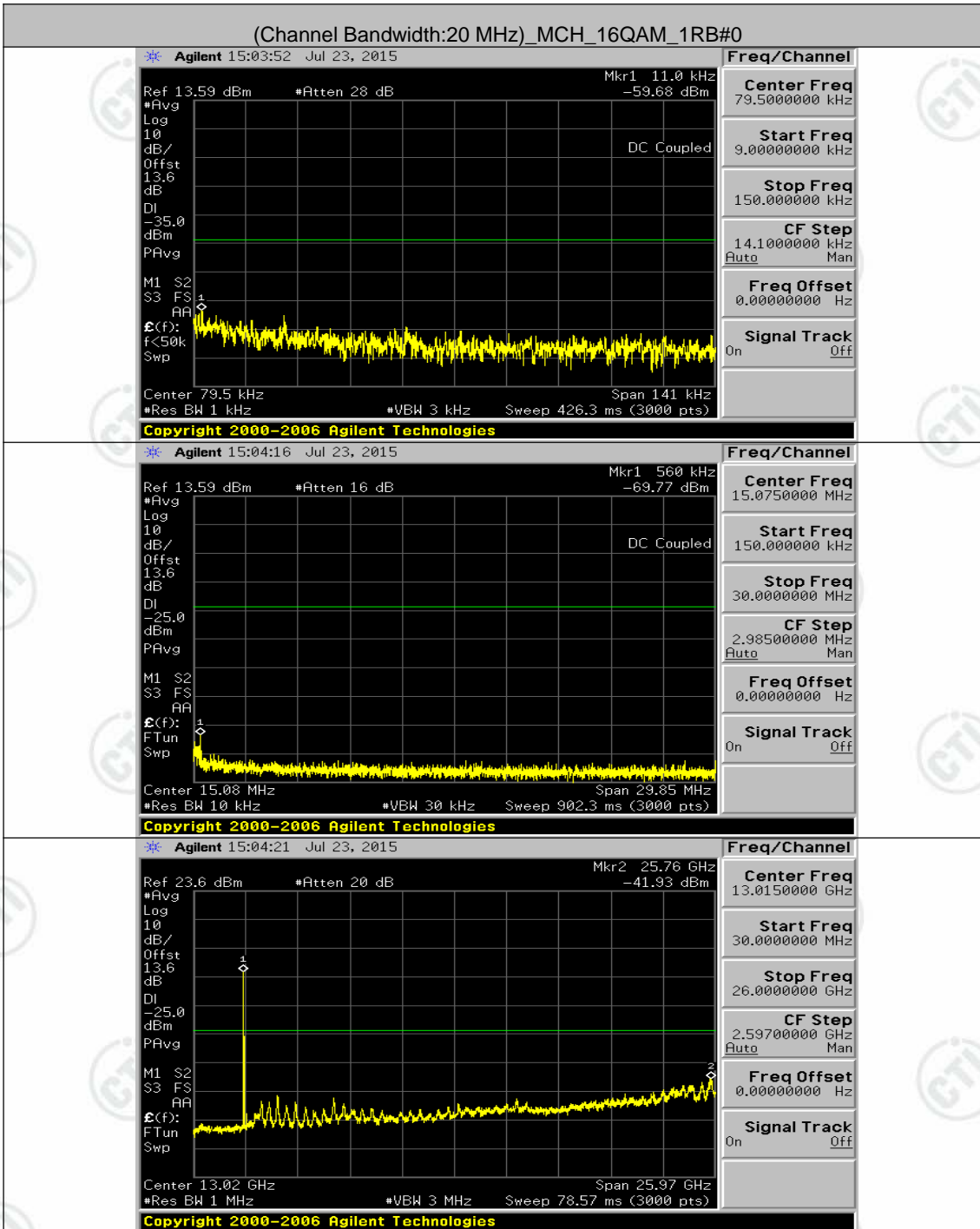

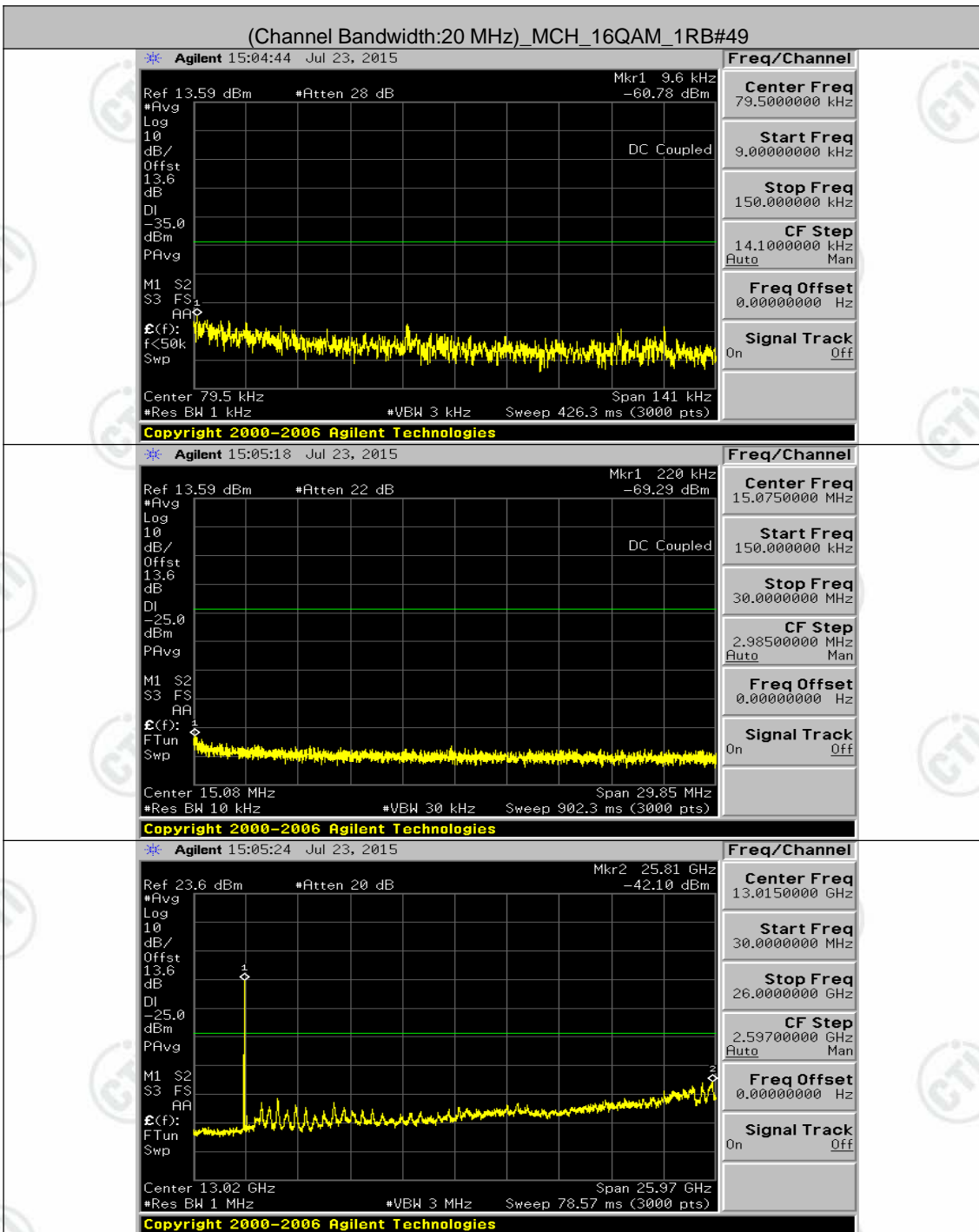

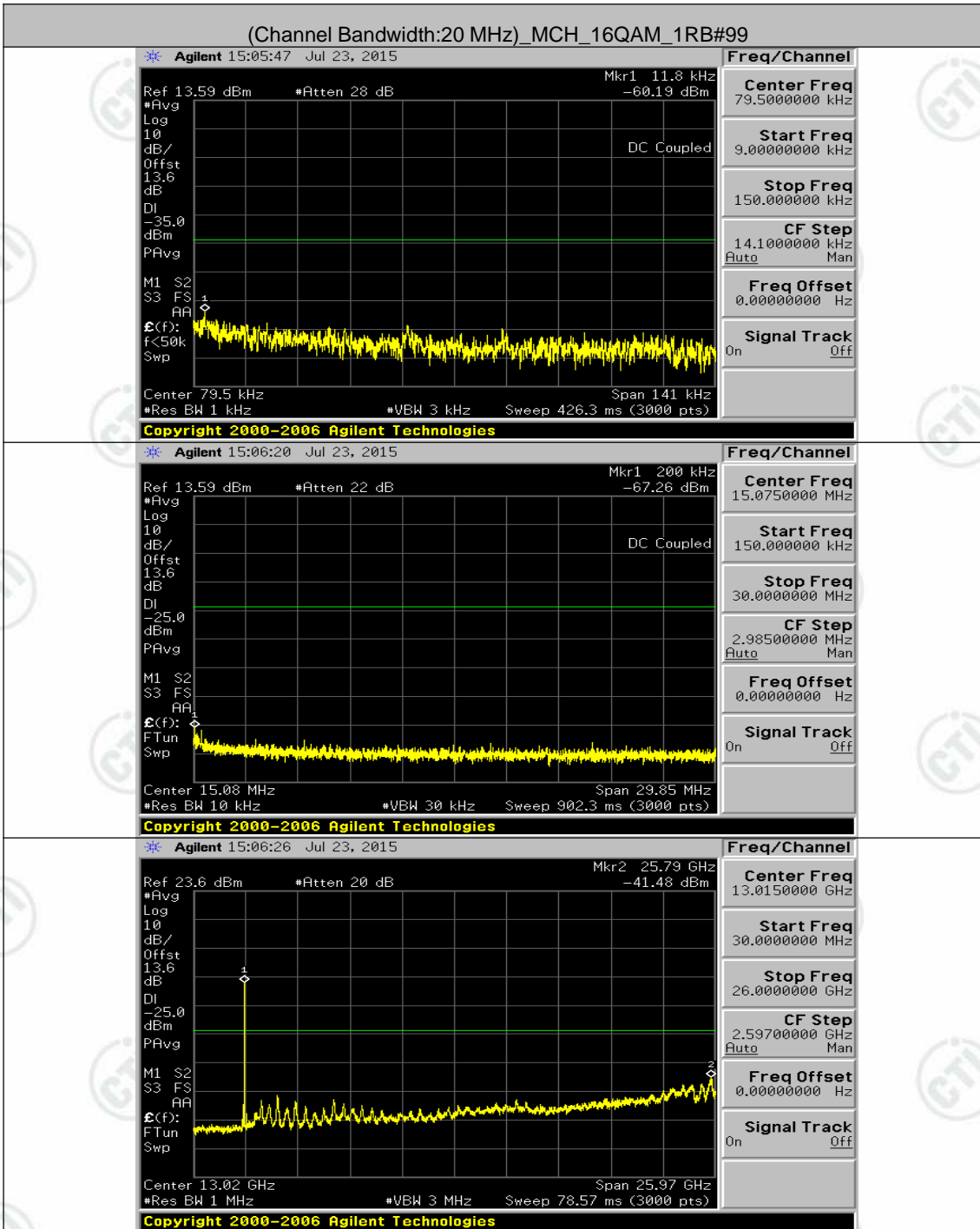

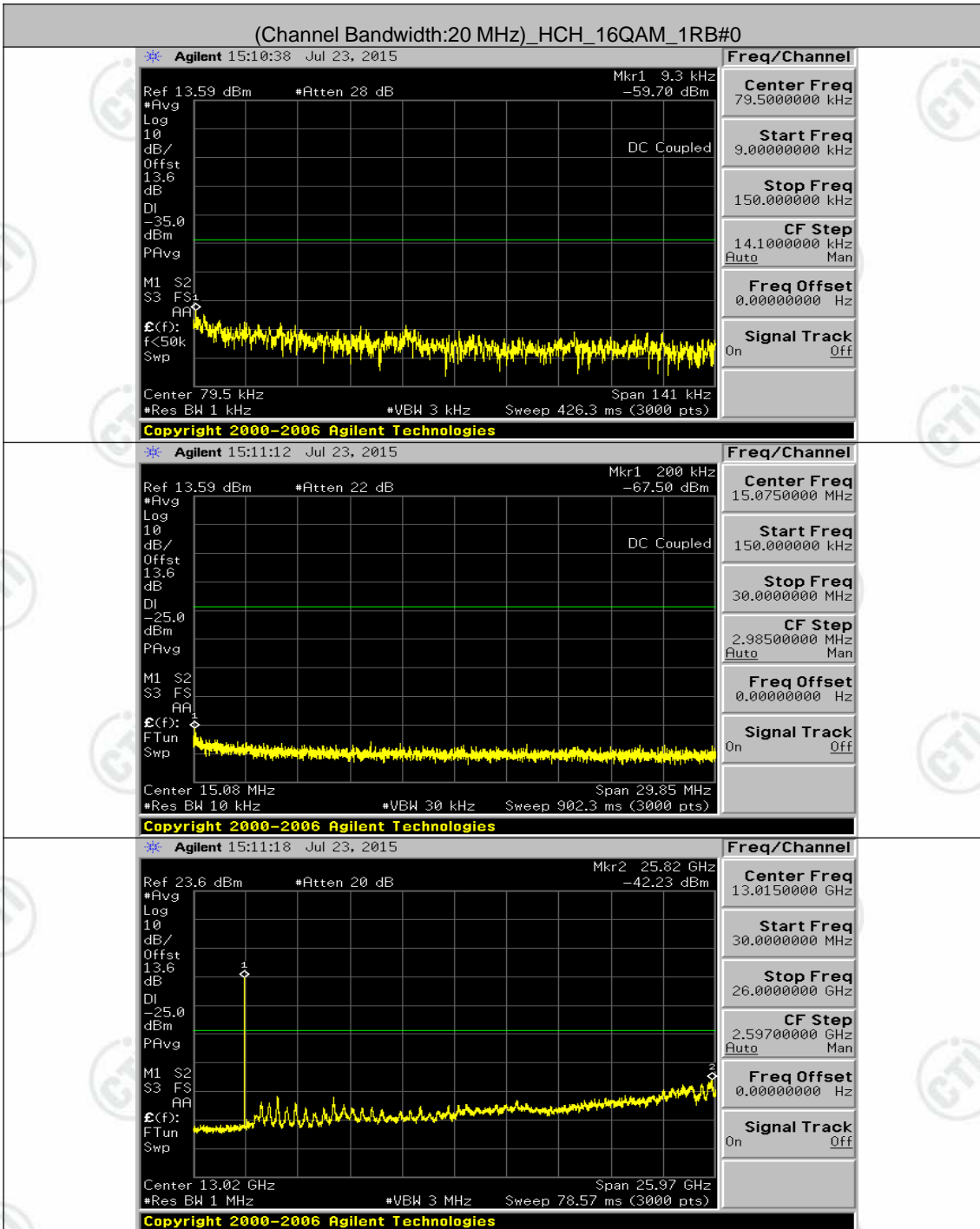

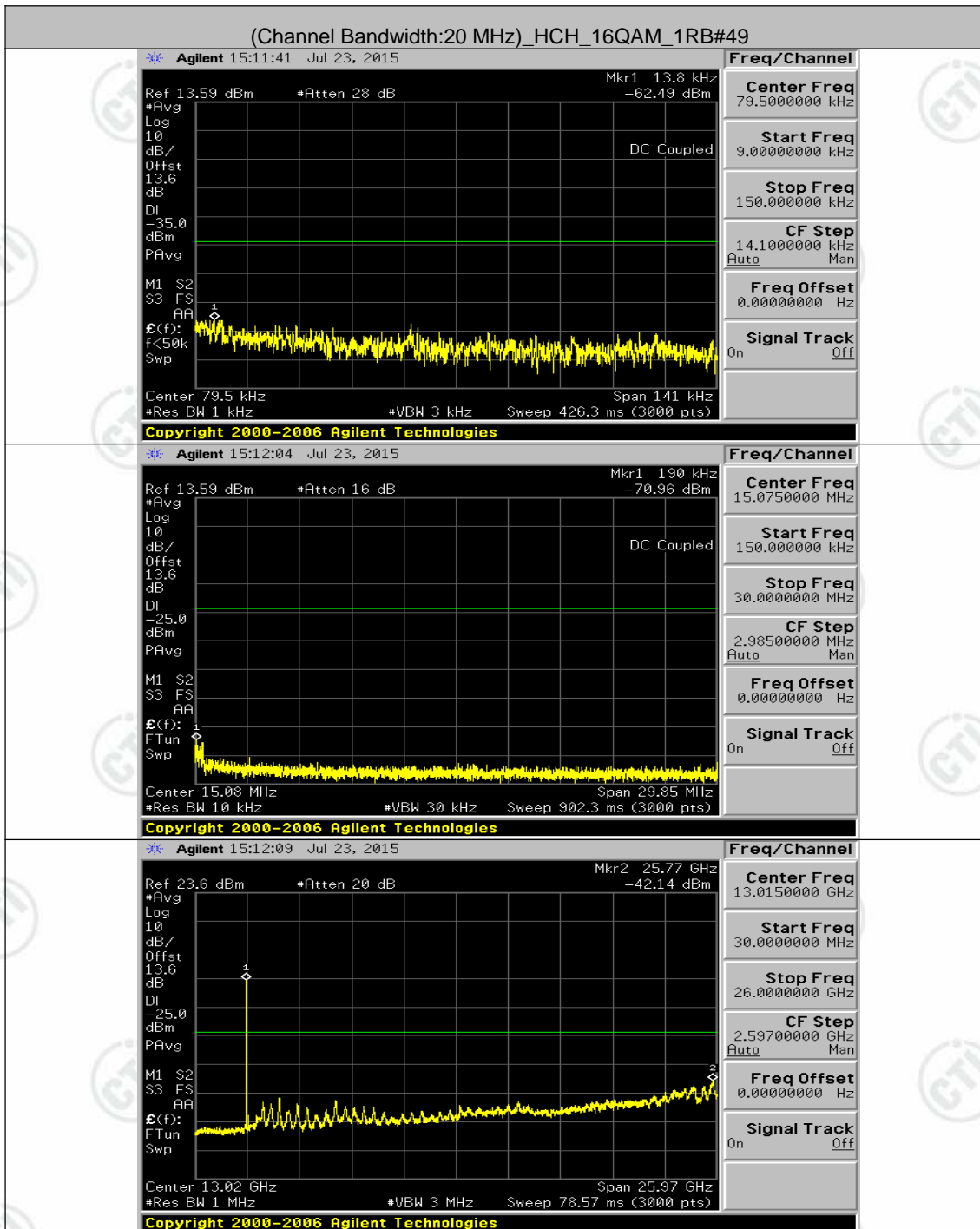

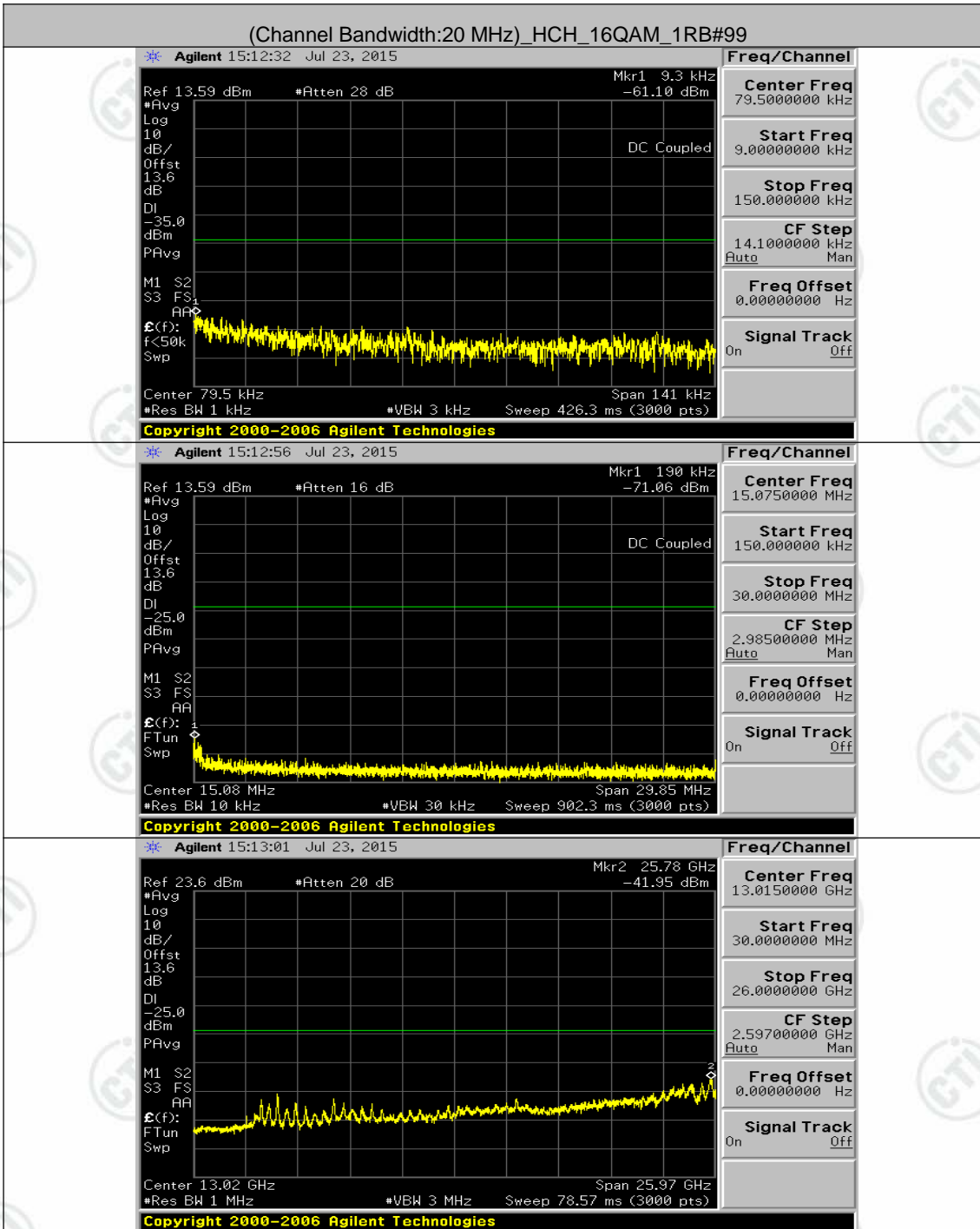

Appendix F: Frequency Stability

Test Result

VL is 3.5V, VN is 3.6V, VH is 3.7V.

Channel Bandwidth: 5 MHz

Channel Bandwidth: 5 MHz							
Voltage							
Modulation	Channel	Voltage [Vdc]	Temperature (°C)	Deviation (Hz)	Deviation (ppm)	Limit (ppm)	Verdict
QPSK	LCH	VL	TN	3.38	0.001349	± 2.5	PASS
		VN	TN	3.25	0.001298	± 2.5	PASS
		VH	TN	-2.53	-0.001012	± 2.5	PASS
	MCH	VL	TN	-3.25	-0.001281	± 2.5	PASS
		VN	TN	-2.53	-0.000999	± 2.5	PASS
		VH	TN	-1.96	-0.000773	± 2.5	PASS
	HCH	VL	TN	0.76	0.000295	± 2.5	PASS
		VN	TN	1.19	0.000462	± 2.5	PASS
		VH	TN	0.97	0.000379	± 2.5	PASS
16QAM	LCH	VL	TN	2.32	0.000926	± 2.5	PASS
		VN	TN	5.51	0.002201	± 2.5	PASS
		VH	TN	-0.26	-0.000103	± 2.5	PASS
	MCH	VL	TN	-1.27	-0.000502	± 2.5	PASS
		VN	TN	-2.12	-0.000835	± 2.5	PASS
		VH	TN	-1.76	-0.000694	± 2.5	PASS
	HCH	VL	TN	1.56	0.000607	± 2.5	PASS
		VN	TN	1.50	0.000585	± 2.5	PASS
		VH	TN	-1.10	-0.000429	± 2.5	PASS
Temperature							
Modulation	Channel	Voltage [Vdc]	Temperature (°C)	Deviation (Hz)	Deviation (ppm)	Limit (ppm)	Verdict
QPSK	LCH	VN	-30	0.14	0.000057	± 2.5	PASS
		VN	-20	1.97	0.000789	± 2.5	PASS
		VN	-10	2.25	0.000897	± 2.5	PASS
		VN	0	-0.62	-0.000246	± 2.5	PASS
		VN	10	3.32	0.001326	± 2.5	PASS
		VN	20	1.72	0.000686	± 2.5	PASS
		VN	30	3.38	0.001349	± 2.5	PASS
		VN	40	4.71	0.001881	± 2.5	PASS
	MCH	VN	-30	-2.30	-0.000909	± 2.5	PASS
		VN	-20	-4.32	-0.001704	± 2.5	PASS
		VN	-10	0.01	0.000006	± 2.5	PASS
		VN	0	0.60	0.000237	± 2.5	PASS
		VN	10	0.06	0.000023	± 2.5	PASS
		VN	20	-3.33	-0.001315	± 2.5	PASS
		VN	30	-2.12	-0.000835	± 2.5	PASS
		VN	40	-2.65	-0.001044	± 2.5	PASS
	HCH	VN	50	-3.09	-0.001219	± 2.5	PASS
		VN	-30	-0.44	-0.000173	± 2.5	PASS
		VN	-20	1.57	0.000613	± 2.5	PASS
		VN	-10	0.76	0.000295	± 2.5	PASS

		VN	0	1.10	0.000429	± 2.5	PASS
		VN	10	0.93	0.000362	± 2.5	PASS
		VN	20	0.62	0.000240	± 2.5	PASS
		VN	30	-0.29	-0.000111	± 2.5	PASS
		VN	40	0.64	0.000251	± 2.5	PASS
		VN	50	0.13	0.000050	± 2.5	PASS
16QAM	LCH	VN	-30	-0.79	-0.000314	± 2.5	PASS
		VN	-20	3.33	0.001332	± 2.5	PASS
		VN	-10	0.39	0.000154	± 2.5	PASS
		VN	0	-0.31	-0.000126	± 2.5	PASS
		VN	10	0.00	0.000000	± 2.5	PASS
		VN	20	-0.39	-0.000154	± 2.5	PASS
		VN	30	4.92	0.001966	± 2.5	PASS
		VN	40	-0.79	-0.000314	± 2.5	PASS
		VN	50	4.31	0.001721	± 2.5	PASS
	MCH	VN	-30	-3.92	-0.001546	± 2.5	PASS
		VN	-20	-2.98	-0.001174	± 2.5	PASS
		VN	-10	-6.27	-0.002472	± 2.5	PASS
		VN	0	-1.29	-0.000508	± 2.5	PASS
		VN	10	-3.38	-0.001332	± 2.5	PASS
		VN	20	-2.49	-0.000982	± 2.5	PASS
		VN	30	-2.47	-0.000976	± 2.5	PASS
		VN	40	-3.22	-0.001270	± 2.5	PASS
		VN	50	-2.03	-0.000801	± 2.5	PASS
	HCH	VN	-30	-0.57	-0.000223	± 2.5	PASS
		VN	-20	3.29	0.001281	± 2.5	PASS
		VN	-10	3.22	0.001254	± 2.5	PASS
		VN	0	3.71	0.001443	± 2.5	PASS
		VN	10	-0.41	-0.000162	± 2.5	PASS
		VN	20	2.93	0.001142	± 2.5	PASS
		VN	30	-0.86	-0.000334	± 2.5	PASS
		VN	40	0.67	0.000262	± 2.5	PASS
		VN	50	-0.53	-0.000206	± 2.5	PASS

Channel Bandwidth: 10 MHz

Channel Bandwidth: 10 MHz							
Voltage							
Modulation	Channel	Voltage [Vdc]	Temperature (°C)	Deviation (Hz)	Deviation (ppm)	Limit (ppm)	Verdict
QPSK	LCH	VL	TN	-2.53	-0.001011	± 2.5	PASS
		VN	TN	-1.77	-0.000708	± 2.5	PASS
		VH	TN	-4.56	-0.001822	± 2.5	PASS
	MCH	VL	TN	-2.37	-0.000937	± 2.5	PASS
		VN	TN	-3.83	-0.001512	± 2.5	PASS
		VH	TN	-2.89	-0.001140	± 2.5	PASS
	HCH	VL	TN	-2.32	-0.000903	± 2.5	PASS
		VN	TN	-2.82	-0.001099	± 2.5	PASS
		VH	TN	-4.31	-0.001679	± 2.5	PASS
16QAM	LCH	VL	TN	-4.86	-0.001942	± 2.5	PASS
		VN	TN	-4.35	-0.001736	± 2.5	PASS
		VH	TN	-1.27	-0.000508	± 2.5	PASS
	MCH	VL	TN	-3.33	-0.001315	± 2.5	PASS
		VN	TN	-2.70	-0.001067	± 2.5	PASS
		VH	TN	-3.13	-0.001236	± 2.5	PASS
	HCH	VL	TN	-2.96	-0.001154	± 2.5	PASS
		VN	TN	-1.90	-0.000742	± 2.5	PASS
		VH	TN	-1.03	-0.000402	± 2.5	PASS
Temperature							
Modulation	Channel	Voltage [Vdc]	Temperature (°C)	Deviation (Hz)	Deviation (ppm)	Limit (ppm)	Verdict
16QAM	LCH	VN	-30	-1.19	-0.000474	± 2.5	PASS
		VN	-20	-0.21	-0.000086	± 2.5	PASS
		VN	-10	-3.96	-0.001582	± 2.5	PASS
		VN	0	-2.56	-0.001022	± 2.5	PASS
		VN	10	-6.07	-0.002421	± 2.5	PASS
		VN	20	-2.80	-0.001119	± 2.5	PASS
		VN	30	-2.37	-0.000948	± 2.5	PASS
		VN	40	-2.75	-0.001096	± 2.5	PASS
	MCH	VN	50	-4.92	-0.001964	± 2.5	PASS
		VN	-30	-3.16	-0.001247	± 2.5	PASS
		VN	-20	-2.19	-0.000863	± 2.5	PASS
		VN	-10	-2.60	-0.001027	± 2.5	PASS
		VN	0	-2.76	-0.001089	± 2.5	PASS
		VN	10	-3.68	-0.001450	± 2.5	PASS
		VN	20	-3.08	-0.001213	± 2.5	PASS
		VN	30	-2.93	-0.001157	± 2.5	PASS
	HCH	VN	40	-4.89	-0.001930	± 2.5	PASS
		VN	50	-2.99	-0.001179	± 2.5	PASS
		VN	-30	-2.75	-0.001071	± 2.5	PASS
		VN	-20	-2.39	-0.000931	± 2.5	PASS
		VN	-10	-1.83	-0.000714	± 2.5	PASS
		VN	0	-2.43	-0.000948	± 2.5	PASS
		VN	10	-3.49	-0.001361	± 2.5	PASS
		VN	20	-4.94	-0.001924	± 2.5	PASS
VN	30	-3.20	-0.001249	± 2.5	PASS		
VN	40	-1.97	-0.000770	± 2.5	PASS		

QPSK	LCH	VN	50	-3.81	-0.001483	± 2.5	PASS
		VN	-30	-4.26	-0.001702	± 2.5	PASS
		VN	-20	-1.39	-0.000554	± 2.5	PASS
		VN	-10	-5.46	-0.002181	± 2.5	PASS
		VN	0	-3.68	-0.001468	± 2.5	PASS
		VN	10	-5.99	-0.002393	± 2.5	PASS
		VN	20	-3.22	-0.001285	± 2.5	PASS
		VN	30	-2.52	-0.001005	± 2.5	PASS
		VN	40	-2.13	-0.000851	± 2.5	PASS
		VN	50	-1.34	-0.000537	± 2.5	PASS
	MCH	VN	-30	-4.31	-0.001699	± 2.5	PASS
		VN	-20	-3.36	-0.001326	± 2.5	PASS
		VN	-10	-6.07	-0.002393	± 2.5	PASS
		VN	0	-1.60	-0.000632	± 2.5	PASS
		VN	10	-3.39	-0.001337	± 2.5	PASS
		VN	20	-3.03	-0.001196	± 2.5	PASS
		VN	30	-4.28	-0.001687	± 2.5	PASS
		VN	40	-3.76	-0.001484	± 2.5	PASS
		VN	50	-3.59	-0.001416	± 2.5	PASS
		HCH	VN	-30	-4.59	-0.001790	± 2.5
	VN		-20	-4.32	-0.001684	± 2.5	PASS
	VN		-10	-2.06	-0.000803	± 2.5	PASS
	VN		0	-1.86	-0.000725	± 2.5	PASS
	VN		10	-0.67	-0.000262	± 2.5	PASS
	VN		20	-3.19	-0.001244	± 2.5	PASS
	VN		30	-7.77	-0.003028	± 2.5	PASS
	VN		40	-3.02	-0.001177	± 2.5	PASS
	VN		50	-4.19	-0.001634	± 2.5	PASS

Channel Bandwidth: 15 MHz

Channel Bandwidth: 15 MHz							
Voltage							
Modulation	Channel	Voltage [Vdc]	Temperature (°C)	Deviation (Hz)	Deviation (ppm)	Limit (ppm)	Verdict
QPSK	LCH	VL	TN	-0.01	-0.000006	± 2.5	PASS
		VN	TN	0.26	0.000103	± 2.5	PASS
		VH	TN	-0.37	-0.000148	± 2.5	PASS
	MCH	VL	TN	-4.71	-0.001857	± 2.5	PASS
		VN	TN	-1.69	-0.000666	± 2.5	PASS
		VH	TN	-2.05	-0.000807	± 2.5	PASS
	HCH	VL	TN	2.19	0.000854	± 2.5	PASS
		VN	TN	1.90	0.000742	± 2.5	PASS
		VH	TN	1.06	0.000413	± 2.5	PASS
16QAM	LCH	VL	TN	-0.27	-0.000108	± 2.5	PASS
		VN	TN	0.29	0.000114	± 2.5	PASS
		VH	TN	0.00	0.000000	± 2.5	PASS
	MCH	VL	TN	-3.85	-0.001518	± 2.5	PASS
		VN	TN	-3.28	-0.001292	± 2.5	PASS
		VH	TN	-3.53	-0.001394	± 2.5	PASS
	HCH	VL	TN	0.19	0.000073	± 2.5	PASS
		VN	TN	1.07	0.000419	± 2.5	PASS
		VH	TN	0.80	0.000313	± 2.5	PASS
Temperature							
Modulation	Channel	Voltage [Vdc]	Temperature (°C)	Deviation (Hz)	Deviation (ppm)	Limit (ppm)	Verdict
QPSK	LCH	VN	-30	-0.29	-0.000114	± 2.5	PASS
		VN	-20	0.11	0.000046	± 2.5	PASS
		VN	-10	-0.26	-0.000103	± 2.5	PASS
		VN	0	-1.13	-0.000451	± 2.5	PASS
		VN	10	0.84	0.000337	± 2.5	PASS
		VN	20	1.22	0.000485	± 2.5	PASS
		VN	30	-0.41	-0.000165	± 2.5	PASS
		VN	40	-0.36	-0.000143	± 2.5	PASS
	MCH	VN	50	-0.67	-0.000268	± 2.5	PASS
		VN	-30	-4.13	-0.001631	± 2.5	PASS
		VN	-20	-4.08	-0.001608	± 2.5	PASS
		VN	-10	-3.60	-0.001422	± 2.5	PASS
		VN	0	-4.46	-0.001761	± 2.5	PASS
		VN	10	-2.92	-0.001151	± 2.5	PASS
		VN	20	-3.05	-0.001202	± 2.5	PASS
		VN	30	-3.22	-0.001270	± 2.5	PASS
	HCH	VN	40	-3.65	-0.001439	± 2.5	PASS
		VN	50	-4.18	-0.001648	± 2.5	PASS
		VN	-30	1.59	0.000620	± 2.5	PASS
		VN	-20	-0.86	-0.000335	± 2.5	PASS
		VN	-10	2.09	0.000815	± 2.5	PASS
		VN	0	0.74	0.000290	± 2.5	PASS
		VN	10	-0.39	-0.000151	± 2.5	PASS
		VN	20	0.74	0.000290	± 2.5	PASS
	VN	30	1.65	0.000642	± 2.5	PASS	
	VN	40	1.43	0.000558	± 2.5	PASS	

16QAM	LCH	VN	50	0.53	0.000207	± 2.5	PASS
		VN	-30	3.52	0.001403	± 2.5	PASS
		VN	-20	3.49	0.001392	± 2.5	PASS
		VN	-10	2.86	0.001141	± 2.5	PASS
		VN	0	3.65	0.001455	± 2.5	PASS
		VN	10	3.96	0.001580	± 2.5	PASS
		VN	20	-0.79	-0.000314	± 2.5	PASS
		VN	30	-0.66	-0.000262	± 2.5	PASS
		VN	40	1.49	0.000593	± 2.5	PASS
		VN	50	-0.86	-0.000342	± 2.5	PASS
	MCH	VN	-30	-3.58	-0.001411	± 2.5	PASS
		VN	-20	-3.98	-0.001569	± 2.5	PASS
		VN	-10	-3.26	-0.001287	± 2.5	PASS
		VN	0	-4.53	-0.001789	± 2.5	PASS
		VN	10	-1.70	-0.000672	± 2.5	PASS
		VN	20	-3.85	-0.001518	± 2.5	PASS
		VN	30	-4.46	-0.001761	± 2.5	PASS
		VN	40	-3.29	-0.001298	± 2.5	PASS
		VN	50	-3.22	-0.001270	± 2.5	PASS
		HCH	VN	-30	2.89	0.001128	± 2.5
	VN		-20	3.62	0.001412	± 2.5	PASS
	VN		-10	1.34	0.000525	± 2.5	PASS
	VN		0	0.83	0.000324	± 2.5	PASS
	VN		10	1.56	0.000608	± 2.5	PASS
	VN		20	2.36	0.000921	± 2.5	PASS
	VN		30	3.35	0.001306	± 2.5	PASS
	VN		40	1.30	0.000508	± 2.5	PASS
	VN		50	2.02	0.000787	± 2.5	PASS

Channel Bandwidth: 20 MHz

Channel Bandwidth: 20 MHz							
Voltage							
Modulation	Channel	Voltage [Vdc]	Temperature (°C)	Deviation (Hz)	Deviation (ppm)	Limit (ppm)	Verdict
QPSK	LCH	VL	TN	0.69	0.000274	± 2.5	PASS
		VN	TN	3.48	0.001385	± 2.5	PASS
		VH	TN	2.37	0.000946	± 2.5	PASS
	MCH	VL	TN	-3.30	-0.001304	± 2.5	PASS
		VN	TN	-2.85	-0.001123	± 2.5	PASS
		VH	TN	-4.18	-0.001648	± 2.5	PASS
	HCH	VL	TN	0.44	0.000173	± 2.5	PASS
		VN	TN	2.07	0.000810	± 2.5	PASS
		VH	TN	3.22	0.001257	± 2.5	PASS
16QAM	LCH	VL	TN	3.09	0.001231	± 2.5	PASS
		VN	TN	2.72	0.001083	± 2.5	PASS
		VH	TN	0.56	0.000222	± 2.5	PASS
	MCH	VL	TN	-2.17	-0.000858	± 2.5	PASS
		VN	TN	-2.99	-0.001179	± 2.5	PASS
		VH	TN	-4.55	-0.001794	± 2.5	PASS
	HCH	VL	TN	-0.76	-0.000296	± 2.5	PASS
		VN	TN	0.70	0.000274	± 2.5	PASS
		VH	TN	-1.36	-0.000531	± 2.5	PASS
Temperature							
Modulation	Channel	Voltage [Vdc]	Temperature (°C)	Deviation (Hz)	Deviation (ppm)	Limit (ppm)	Verdict
QPSK	LCH	VN	-30	1.60	0.000638	± 2.5	PASS
		VN	-20	4.23	0.001687	± 2.5	PASS
		VN	-10	2.75	0.001094	± 2.5	PASS
		VN	0	3.08	0.001225	± 2.5	PASS
		VN	10	2.47	0.000986	± 2.5	PASS
		VN	20	3.72	0.001482	± 2.5	PASS
		VN	30	1.44	0.000576	± 2.5	PASS
		VN	40	3.95	0.001573	± 2.5	PASS
	MCH	VN	50	4.42	0.001761	± 2.5	PASS
		VN	-30	0.37	0.000147	± 2.5	PASS
		VN	-20	0.21	0.000085	± 2.5	PASS
		VN	-10	-1.82	-0.000717	± 2.5	PASS
		VN	0	-2.15	-0.000846	± 2.5	PASS
		VN	10	-0.30	-0.000119	± 2.5	PASS
		VN	20	-3.79	-0.001495	± 2.5	PASS
		VN	30	-3.93	-0.001552	± 2.5	PASS
	HCH	VN	40	-3.68	-0.001450	± 2.5	PASS
		VN	50	-1.60	-0.000632	± 2.5	PASS
		VN	-30	0.10	0.000039	± 2.5	PASS
		VN	-20	-2.43	-0.000950	± 2.5	PASS
		VN	-10	0.01	0.000006	± 2.5	PASS
		VN	0	-1.83	-0.000715	± 2.5	PASS
		VN	10	-0.29	-0.000112	± 2.5	PASS
		VN	20	0.44	0.000173	± 2.5	PASS
	VN	30	1.85	0.000721	± 2.5	PASS	
	VN	40	-0.13	-0.000050	± 2.5	PASS	

16QAM	LCH	VN	50	-0.50	-0.000196	± 2.5	PASS
		VN	-30	2.90	0.001157	± 2.5	PASS
		VN	-20	0.83	0.000331	± 2.5	PASS
		VN	-10	2.63	0.001049	± 2.5	PASS
		VN	0	2.40	0.000957	± 2.5	PASS
		VN	10	1.79	0.000712	± 2.5	PASS
		VN	20	3.48	0.001385	± 2.5	PASS
		VN	30	4.92	0.001961	± 2.5	PASS
		VN	40	2.16	0.000861	± 2.5	PASS
		VN	50	3.72	0.001482	± 2.5	PASS
	MCH	VN	-30	-0.17	-0.000068	± 2.5	PASS
		VN	-20	-0.11	-0.000045	± 2.5	PASS
		VN	-10	-0.29	-0.000113	± 2.5	PASS
		VN	0	-0.19	-0.000073	± 2.5	PASS
		VN	10	-0.17	-0.000068	± 2.5	PASS
		VN	20	-4.63	-0.001828	± 2.5	PASS
		VN	30	-0.13	-0.000051	± 2.5	PASS
		VN	40	-5.29	-0.002088	± 2.5	PASS
		VN	50	-3.43	-0.001354	± 2.5	PASS
		HCH	VN	-30	0.73	0.000285	± 2.5
	VN		-20	-0.54	-0.000212	± 2.5	PASS
	VN		-10	0.41	0.000162	± 2.5	PASS
	VN		0	0.96	0.000374	± 2.5	PASS
	VN		10	0.62	0.000240	± 2.5	PASS
	VN		20	0.84	0.000330	± 2.5	PASS
	VN		30	-1.90	-0.000743	± 2.5	PASS
	VN		40	0.73	0.000285	± 2.5	PASS
	VN		50	1.36	0.000531	± 2.5	PASS

Appendix G: Field strength of spurious radiation

Receiver Setup:	<table border="1"> <thead> <tr> <th>Frequency</th> <th>Detector</th> <th>RBW</th> <th>VBW</th> <th>Remark</th> </tr> </thead> <tbody> <tr> <td>0.009MHz-30MHz</td> <td>Peak</td> <td>10kHz</td> <td>30kHz</td> <td>Peak</td> </tr> <tr> <td>30MHz-1GHz</td> <td>Peak</td> <td>120kHz</td> <td>300kHz</td> <td>Peak</td> </tr> <tr> <td>Above 1GHz</td> <td>Peak</td> <td>1MHz</td> <td>3MHz</td> <td>Peak</td> </tr> </tbody> </table>	Frequency	Detector	RBW	VBW	Remark	0.009MHz-30MHz	Peak	10kHz	30kHz	Peak	30MHz-1GHz	Peak	120kHz	300kHz	Peak	Above 1GHz	Peak	1MHz	3MHz	Peak
Frequency	Detector	RBW	VBW	Remark																	
0.009MHz-30MHz	Peak	10kHz	30kHz	Peak																	
30MHz-1GHz	Peak	120kHz	300kHz	Peak																	
Above 1GHz	Peak	1MHz	3MHz	Peak																	
Measurement Procedure:	<ol style="list-style-type: none"> 1. Scan up to 10th harmonic, find the maximum radiation frequency to measure. 2. The technique used to find the Spurious Emissions of the transmitter was the antenna substitution method. Substitution method was performed to determine the actual ERP/EIRP emission levels of the EUT. <p>Test procedure as below:</p> <ol style="list-style-type: none"> 1) The EUT was powered ON and placed on a 1.5m high table at a 3 meter fully Anechoic Chamber. The antenna of the transmitter was extended to its maximum length. modulation mode and the measuring receiver shall be tuned to the frequency of the transmitter under test. 2) The EUT was set 3 meters(above 18GHz the distance is 1 meter) away from the interference-receiving antenna, which was mounted on the top of a variable-height antenna tower. 3) The disturbance of the transmitter was maximized on the test receiver display by raising and lowering from 1m to 4m the receive antenna and by rotating through 360° the turntable. After the fundamental emission was maximized, a field strength measurement was made. 4) Steps 1) to 3) were performed with the EUT and the receive antenna in both vertical and horizontal polarization. 5) The transmitter was then removed and replaced with another antenna. The center of the antenna was approximately at the same location as the center of the transmitter. 6) A signal at the disturbance was fed to the substitution antenna by means of a non-radiating cable. With both the substitution and the receive antennas horizontally polarized, the receive antenna was raised and lowered to obtain a maximum reading at the test receiver. The level of the signal generator was adjusted until the measured field strength level in step 3) is obtained for this set of conditions. 7) The output power into the substitution antenna was then measured. 8) Steps 6) and 7) were repeated with both antennas polarized. 9) Calculate power in dBm by the following formula: $\text{ERP(dBm)} = \text{Pg(dBm)} - \text{cable loss (dB)} + \text{antenna gain (dBd)}$ $\text{EIRP(dBm)} = \text{Pg(dBm)} - \text{cable loss (dB)} + \text{antenna gain (dBi)}$ $\text{EIRP} = \text{ERP} + 2.15\text{dB}$ <p>where: Pg is the generator output power into the substitution antenna.</p> 10) Test the EUT in the lowest channel, the middle channel the Highest channel 11) The radiation measurements are performed in X, Y, Z axis positioning for EUT operation mode, And found the X axis positioning which it is worse case. 12) Repeat above procedures until all frequencies measured was complete. 																				
Limit:	Attenuated at least 43+10log(P)																				

Test Data:
Above 1GHz
QPSK

Band 7 20775 channel/BW5(lowest channel)							
Frequency (MHz)	Height (cm)	Azimuth (deg)	Spurious Emission Level (dBm)	Limit (dBm)	Over Limit (dB)	Result	Antenna Polaxis.
1127.091	151	336	-56.15	-13.00	-43.15	Pass	H
1553.293	150	20	-56.41	-13.00	-43.41	Pass	H
3776.385	155	174	-50.81	-13.00	-37.81	Pass	H
5009.426	150	50	-42.42	-13.00	-29.42	Pass	H
6347.466	150	158	-45.70	-13.00	-32.70	Pass	H
7508.688	156	91	-44.08	-13.00	-31.08	Pass	H
1124.226	149	200	-57.22	-13.00	-44.22	Pass	V
1541.476	158	36	-57.25	-13.00	-44.25	Pass	V
3700.260	150	55	-50.10	-13.00	-37.10	Pass	V
5009.426	150	10	-45.91	-13.00	-32.91	Pass	V
6461.583	155	27	-46.17	-13.00	-33.17	Pass	V
7508.688	144	11	-43.09	-13.00	-30.09	Pass	V

Band 7 21100 channel/BW5(middle channel)							
Frequency (MHz)	Height (cm)	Azimuth (deg)	Spurious Emission Level (dBm)	Limit (dBm)	Over Limit (dB)	Result	Antenna Polaxis.
1118.517	158	114	-56.73	-13.00	-43.73	Pass	H
1553.293	150	100	-57.26	-13.00	-44.26	Pass	H
5073.591	144	251	-46.55	-13.00	-33.55	Pass	H
6396.125	150	36	-46.22	-13.00	-33.22	Pass	H
7604.867	156	200	-45.56	-13.00	-32.56	Pass	H
9834.406	150	78	-46.33	-13.00	-33.33	Pass	H
1124.226	150	54	-57.34	-13.00	-44.34	Pass	V
1549.344	158	121	-56.99	-13.00	-43.99	Pass	V
3776.385	150	20	-50.64	-13.00	-37.64	Pass	V
5073.591	154	33	-39.73	-13.00	-26.73	Pass	V
6527.712	160	11	-46.13	-13.00	-33.13	Pass	V
7604.867	150	20	-45.54	-13.00	-32.54	Pass	V

Band 7 20425 channel/BW5(highest channel)							
Frequency (MHz)	Height (cm)	Azimuth (deg)	Spurious Emission Level (dBm)	Limit (dBm)	Over Limit (dB)	Result	Antenna Polaxis.
1110.008	150	88	-55.79	-13.00	-42.79	Pass	H
1764.123	154	224	-55.30	-13.00	-42.30	Pass	H
5138.579	150	110	-43.03	-13.00	-30.03	Pass	H
6396.125	155	360	-46.01	-13.00	-33.01	Pass	H
7941.185	148	78	-46.83	-13.00	-33.83	Pass	H
9859.472	150	22	-46.31	-13.00	-33.31	Pass	H
1135.731	150	59	-55.98	-13.00	-42.98	Pass	V
1768.619	150	10	-55.69	-13.00	-42.69	Pass	V
5138.579	154	45	-46.02	-13.00	-33.02	Pass	V
6478.053	150	110	-45.37	-13.00	-32.37	Pass	V
8002.061	155	64	-46.54	-13.00	-33.54	Pass	V
9538.543	148	20	-46.40	-13.00	-33.40	Pass	V

16QAM

Band 7 20775 channel/BW5(lowest channel)							
Frequency (MHz)	Height (cm)	Azimuth (deg)	Spurious Emission Level (dBm)	Limit (dBm)	Over Limit (dB)	Result	Antenna Polaxis.
1124.226	155	336	-56.63	-13.00	-43.63	Pass	H
1573.189	147	20	-56.65	-13.00	-43.65	Pass	H
5009.426	150	11	-42.94	-13.00	-29.94	Pass	H
6527.712	151	247	-45.94	-13.00	-32.94	Pass	H
7508.688	150	226	-45.50	-13.00	-32.50	Pass	H
9759.591	156	89	-46.48	-13.00	-33.48	Pass	H
1118.517	158	360	-55.99	-13.00	-42.99	Pass	V
1545.405	155	78	-57.15	-13.00	-44.15	Pass	V
3824.757	150	200	-50.82	-13.00	-37.82	Pass	V
5009.426	154	54	-43.28	-13.00	-30.28	Pass	V
6527.712	149	81	-46.36	-13.00	-33.36	Pass	V
7508.688	150	51	-43.49	-13.00	-30.49	Pass	V

Band 7 21100 channel/BW5(middle channel)							
Frequency (MHz)	Height (cm)	Azimuth (deg)	Spurious Emission Level (dBm)	Limit (dBm)	Over Limit (dB)	Result	Antenna Polaxis.
1156.150	151	51	-56.32	-13.00	-43.32	Pass	H
1759.638	158	77	-55.43	-13.00	-42.43	Pass	H
5284.497	150	213	-49.45	-13.00	-36.45	Pass	H
5880.782	150	20	-46.61	-13.00	-33.61	Pass	H
6445.156	150	68	-45.92	-13.00	-32.92	Pass	H
8462.975	148	200	-47.33	-13.00	-34.33	Pass	H
1150.279	141	151	-57.07	-13.00	-44.07	Pass	V
1553.293	150	20	-56.76	-13.00	-43.76	Pass	V
5073.591	158	67	-47.16	-13.00	-34.16	Pass	V
6494.564	156	338	-45.19	-13.00	-32.19	Pass	V
7981.717	150	20	-46.41	-13.00	-33.41	Pass	V
9228.060	150	49	-45.98	-13.00	-32.98	Pass	V

Band 7 20425 channel/BW5(highest channel)							
Frequency (MHz)	Height (cm)	Azimuth (deg)	Spurious Emission Level (dBm)	Limit (dBm)	Over Limit (dB)	Result	Antenna Polaxis.
1132.844	151	55	-55.54	-13.00	-42.54	Pass	H
1782.177	150	11	-55.43	-13.00	-42.43	Pass	H
5138.579	152	261	-42.17	-13.00	-29.17	Pass	H
6511.117	148	200	-45.03	-13.00	-32.03	Pass	H
8615.126	150	315	-46.96	-13.00	-33.96	Pass	H
9636.161	153	78	-46.21	-13.00	-33.21	Pass	H
1135.731	156	91	-56.32	-13.00	-43.32	Pass	V
1561.221	150	200	-56.74	-13.00	-43.74	Pass	V
5138.579	151	45	-44.37	-13.00	-31.37	Pass	V
6445.156	155	36	-46.20	-13.00	-33.20	Pass	V
7702.278	160	110	-46.15	-13.00	-33.15	Pass	V
9809.404	148	72	-46.02	-13.00	-33.02	Pass	V

Note:

- 1) Scan from 9kHz to 25GHz, the disturbance above 13GHz and below 1GHz are attenuated more than 20 dB below the applicable limit and not required to be reported, the above harmonics were the highest point could be found when testing, so only the above harmonics had been displayed.
- 2) Tested with all kind of bandwidth, RB Size and RB Offset, Found the 5MHz with full RB were the worst case; and then Only the worst case is recorded in the report.

PHOTOGRAPHS OF TEST SETUP

Test model No.: BW-X07HD

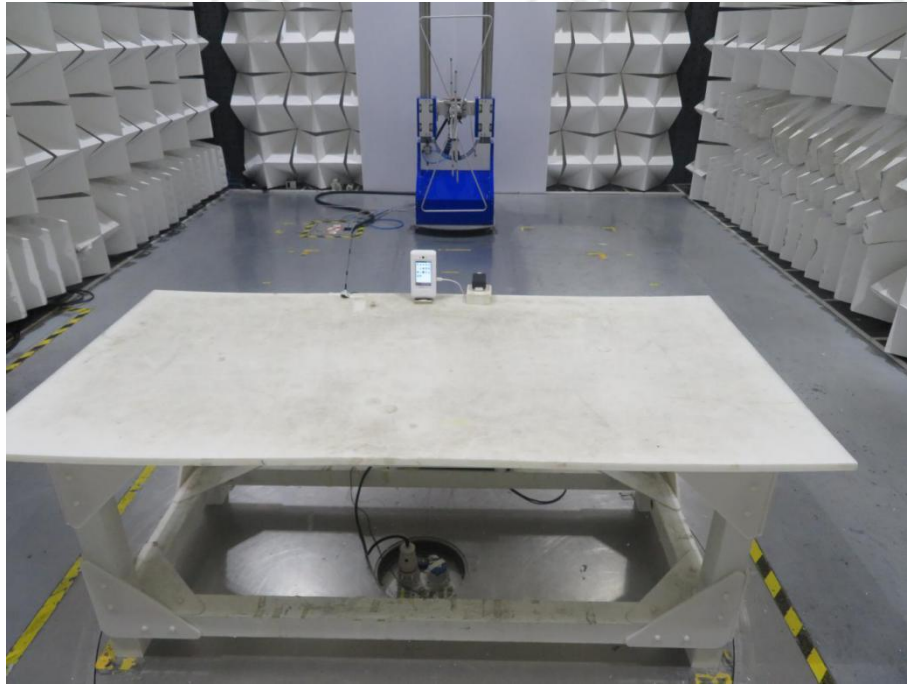

Radiated spurious emission Test Setup-1(Below 1GHz)



Radiated spurious emission Test Setup-2(Above 1GHz)

PHOTOGRAPHS OF EUT Constructional Details

Refer to Report No.EED32100251301 for EUT external and internal photos.

*** End of Report ***

The test report is effective only with both signature and specialized stamp, The result(s) shown in this report refer only to the sample(s) tested. Without written approval of CTI, this report can't be reproduced except in full.