

TEST REPORT

Product : HANDHELD VITALSIGNS
MONITORING SYSTEM
Trade mark : **bewell**
connect
Model/Type reference : BW-X07HD
Serial Number : N/A
Report Number : EED32100251306
FCC ID : 2AF8T-BW-X07HD
Date of Issue : Jun. 14, 2017
Test Standards : 47 CFR Part 2(2015)
47 CFR Part 27 subpart C(2015)
Test result : PASS

Prepared for:

BEWELL CONNECT CORP
SUITE 410, 185 ALEWIFE BROOK PARKWAY
CAMBRIDGE, Massachusetts, United States

Prepared by:

Centre Testing International Group Co., Ltd.
Hongwei Industrial Zone, Bao'an 70 District,
Shenzhen, Guangdong, China
TEL: +86-755-3368 3668
FAX: +86-755-3368 3385

Tested By:

Tom chen

Tom chen (Test Project)

Compiled by:

Kevin lan

Kevin lan (Project Engineer)

Reviewed by:

Kevin yang

Kevin yang (Reviewer)

Approved by:

Sheek Luo

Sheek Luo (Lab supervisor)

Date:

Jun. 14, 2017

Check No.: 2392125448



2 Version

Version No.	Date	Description
00	Jun. 14, 2017	Original

3 Test Summary

LTE band 4			
Test Item	Test Requirement	Test method	Result
Conducted output power	Part 2.1046(a) /Part 27.50(d)	TIA-603-D-2010 & KDB 971168 D01v02r02	PASS
Effective Radiated Power of Transmitter(EIRP)	Part 2.1046(a) / Part 27.50(d)	TIA-603-D-2010 & KDB 971168 D01v02r02	PASS
peak-to-average ratio	Part 27.50(d)	KDB 971168 D01v02r02	PASS
99% &26dBOccupied Bandwidth	Part 2.1049(h)	Part 27.53(h) & KDB 971168 D01v02r02	PASS
Band Edge at antenna terminals	Part 2.1051/ Part 27.53(h)	Part 27.53(h) & KDB 971168 D01v02r02	PASS
Spurious emissions at antenna terminals	Part 2.1051/ Part 27.53(h)	TIA-603-D-2010 & KDB 971168 D01v02r02	PASS
Field strength of spurious radiation	Part 2.1053/ Part 27.53(h)	TIA-603-D-2010 & KDB 971168 D01v02r02	PASS
Frequency stability	Part 2.1055/Part 27.54	TIA-603-D-2010 & KDB 971168 D01v02r02	PASS

Remark:The tested samples and the sample information are provided by the client.

4 Content

1 COVER PAGE	1
2 VERSION	2
3 TEST SUMMARY	3
4 CONTENT	4
5 TEST REQUIREMENT	5
5.1 TEST SETUP.....	5
5.1.1 For Conducted test setup.....	5
5.1.2 For Radiated Emissions test setup.....	5
5.2 TEST ENVIRONMENT.....	5
5.3 TEST CONDITION.....	6
6 GENERAL INFORMATION	7
6.1 CLIENT INFORMATION.....	7
6.2 GENERAL DESCRIPTION OF EUT.....	7
6.3 PRODUCT SPECIFICATION SUBJECTIVE TO THIS STANDARD.....	8
6.4 DESCRIPTION OF SUPPORT UNITS.....	8
6.5 TEST LOCATION.....	8
6.6 TEST FACILITY.....	8
6.7 DEVIATION FROM STANDARDS.....	8
6.8 ABNORMALITIES FROM STANDARD CONDITIONS.....	8
6.9 OTHER INFORMATION REQUESTED BY THE CUSTOMER.....	8
6.10 MEASUREMENT UNCERTAINTY (95% CONFIDENCE LEVELS, K=2).....	8
7 EQUIPMENT LIST	9
8 RADIO TECHNICAL REQUIREMENTS SPECIFICATION	11
APPENDIX A: CONDUCTED OUTPUT POWER AND EFFECTIVE (ISOTROPIC) RADIATED POWER.....	12
APPENDIX B: PEAK-TO-AVERAGE RATIO.....	21
APPENDIX C: 26DB BANDWIDTH AND OCCUPIED BANDWIDTH.....	113
APPENDIX D: BAND EDGE.....	127
APPENDIX E: CONDUCTED SPURIOUS EMISSION.....	183
APPENDIX F: FREQUENCY STABILITY.....	291
APPENDIX G): FIELD STRENGTH OF SPURIOUS RADIATION.....	301
PHOTOGRAPHS OF TEST SETUP	305
PHOTOGRAPHS OF EUT CONSTRUCTIONAL DETAILS	306

5 Test Requirement

5.1 Test setup

5.1.1 For Conducted test setup

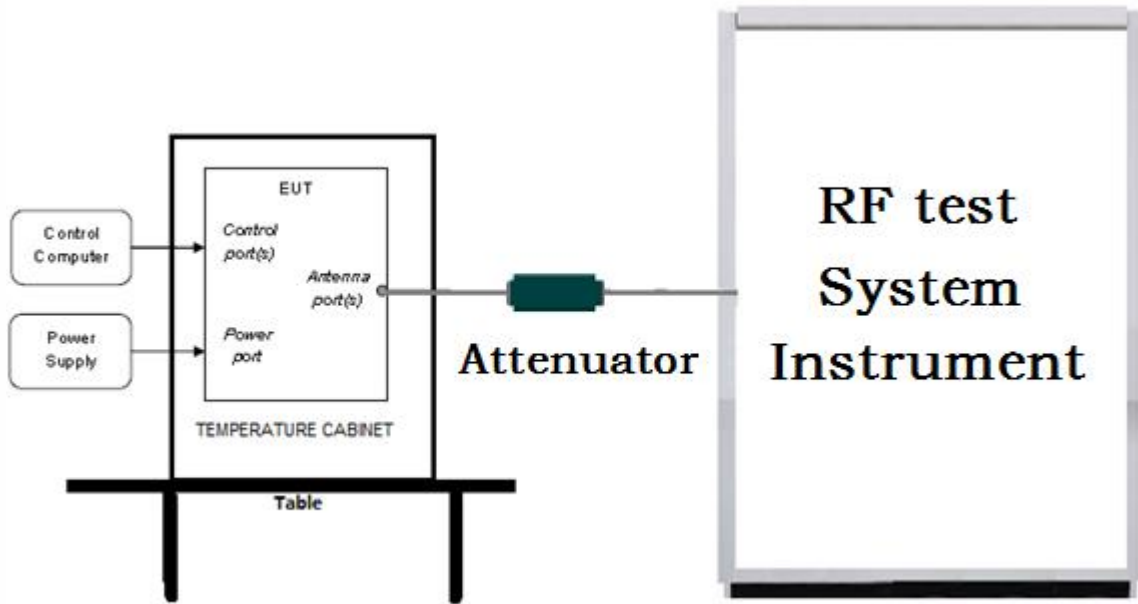

5.1.2 For Radiated Emissions test setup

Radiated Emissions setup:

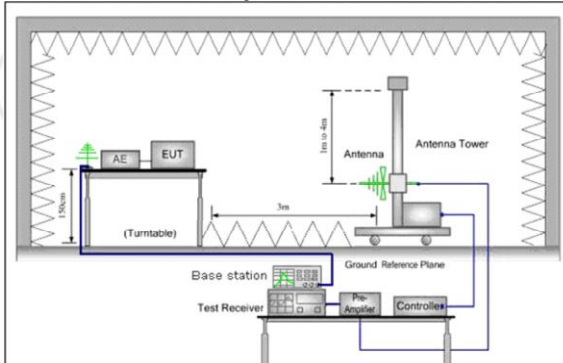

Figure 1.30MHz to 1GHz

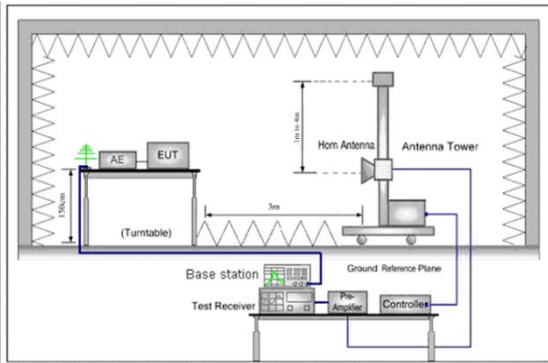

Figure 2. above 1GHz

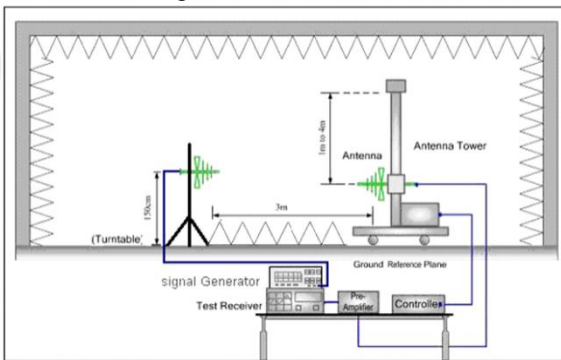

Figure 1. 30MHz to 1GHz

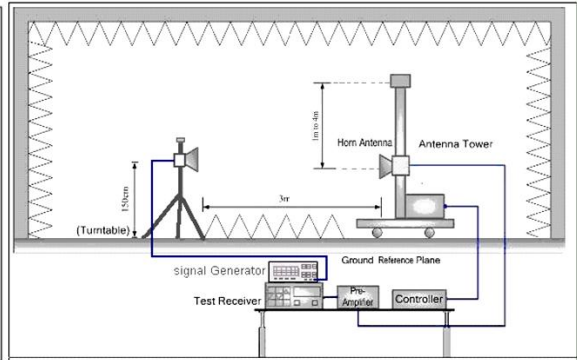

Figure 2. above 1GHz

5.2 Test Environment

Operating Environment:	
Temperature:	23°C
Humidity:	51% RH
Atmospheric Pressure:	1010mbar

5.3 Test Condition

Test channel:

LTE



Test Mode	Test Frequency ID	Bandwidth (MHz)	Number [UL]	Frequency of Uplink(MHz)	Number [DL]	Frequency of Downlink(MHz)
LTE band 4 TX:1710-1755 MHz RX: 2110-2155MHz	Low Range	1.4	19957	1710.7	1957	2110.7
		3	19965	1711.5	1965	2111.5
		5	19975	1712.5	1975	2112.5
		10	20000	1715	2000	2115.0
		15	20025	1717.5	2026	2117.5
	Mid Range	1.4/3/5/10/15/20	20175	1732.5	2175	2132.5
	High Range	1.4	20393	1754.3	2393	2154.3
		3	20385	1753.5	2385	2153.5
		5	20375	1752.5	2375	2152.5
		10	20350	1750	2350	2160.0
		15	20325	1747.5	2325	2147.5
		20	20300	1745	2300	2145.0

6 General Information

6.1 Client Information

Applicant:	BEWELL CONNECT CORP
Address of Applicant:	SUITE 410, 185 ALEWIFE BROOK PARKWAY CAMBRIDGE, Massachusetts, United States
Manufacturer:	Visiomed Technology Co., Ltd
Address of Manufacturer:	2 Floor of No.1 Building, Jia An Technological Industrial Park, 67 District, Bao An, 518101 Shenzhen China
Factory:	Visiomed Technology Co., Ltd
Address of Factory:	2 Floor of No.1 Building, Jia An Technological Industrial Park, 67 District, Bao An, 518101 Shenzhen China

6.2 General Description of EUT

Product Name:	HANDHELD VITALSIGNS MONITORING SYSTEM	
Test Model No.(EUT):	BW-X07HD	
Trade mark:		
EUT Supports Radios application:	<p>LTE Band 2: TX:1850 MHz to 1910 MHz RX:1930 MHz to 1990 MHz.</p> <p>LTE Band 4: TX:1710 MHz to 1755 MHz RX:2110 MHz to 2170 MHz.</p> <p>LTE band 7: TX:2500 MHz to 2570 MHz RX:2620 MHz to 2690 MHz.</p> <p>LTE band 12: TX: 699 MHz to 716 MHz RX: 729 MHz to 746 MHz.</p> <p>WCDMA1900: TX:1850 MHz to 1910 MHz RX:1930 MHz to 1990 MHz.</p> <p>WIFI 802.11b/g/n(20)/n(40): TX/RX:2412 MHz to 2462 MHz</p> <p>BT4.0 Dual mode: 2402 MHz to 2480 MHz.</p> <p>GPS:1575.42MHz</p>	
Power Supply:	AC adapter:	<p>MODEL No.:UE10WCP1-050200SPA</p> <p>PART No.:UE160106HKWY1-P</p> <p>INPUT:100-240V~50/60Hz, 500mA</p> <p>OUTPUT:5.0V  2.0A</p>
	Battery:	2500mAh 3.7V (Rechargeable Li-ion Battery)
Hardware Version:	(manufacturer declare)H.VS.MSM8909.02	
Software Version:	(manufacturer declare)Visiocheck_1.0.6	
Sample Received Date:	Oct. 19, 2016	
Sample tested Date:	Oct. 19, 2016 to Jun. 13, 2017	

6.3 Product Specification subjective to this standard

Frequency Band:	LTE Band 4: TX:1710 MHz to 1755 MHz RX:2110 MHz to 2170 MHz.
Modulation Type:	LTE Mode with QPSK,16QAM Modulation
Sample Type:	Portable production
Antenna Type:	Internal antenna
Antenna Gain:	LTE Band 4: 2.5dBi
Test Voltage:	AC 120V, 60Hz

6.4 Description of Support Units

The EUT has been tested independently.

6.5 Test Location

All tests were performed at:

Centre Testing International Group Co., Ltd.

Hongwei Industrial Zone, Bao'an 70 District, Shenzhen, Guangdong, China 518101

Telephone: +86 (0) 755 33683668 Fax:+86 (0) 755 33683385

No tests were sub-contracted.

6.6 Test Facility

FCC-Registration No.: 886427

Centre Testing International Group Co., Ltd. EMC Laboratory has been registered and fully described in a report filed with the FCC (Federal Communications Commission). The acceptance letter from the FCC is maintained in our files. Registration 886427.

6.7 Deviation from Standards

None.

6.8 Abnormalities from Standard Conditions

None.

6.9 Other Information Requested by the Customer

None.

6.10 Measurement Uncertainty (95% confidence levels, k=2)

No.	Item	Measurement Uncertainty
1	Radio Frequency	7.9×10^{-8}
2	RF power, conducted	0.31dB (30MHz-1GHz)
		0.57dB (1GHz-18GHz)
3	Radiated Spurious emission test	4.5dB (30MHz-1GHz)
		4.8dB (1GHz-12.75GHz)
4	Conduction emission	3.6dB (9kHz to 150kHz)
		3.2dB (150kHz to 30MHz)
5	Temperature test	0.64°C
6	Humidity test	2.8%
7	DC power voltages	0.025%

7 Equipment List

Communication RF test system					
Equipment	Manufacturer	Mode No.	Serial Number	Cal. Date (mm-dd-yyyy)	Cal. Due date (mm-dd-yyyy)
Spectrum Analyzer	Agilent	E4440A	MY46185649	12-16-2016	12-15-2017
Signal Generator	Agilent	E4438C	MY45095744	03-14-2017	03-13-2018
Communication test set	Agilent	E5515C	GB47050534	03-14-2017	03-13-2018
Signal Generator	Keysight	E8257D	MY53401106	03-14-2017	03-13-2018
Communication test set	R&S	CMW500	152394	03-14-2017	03-13-2018
High-pass filter	Sinoscite	FL3CX03WG18 NM12-0398-002	---	01-12-2017	01-11-2018
High-pass filter	MICRO-TRONICS	SPA-F-63029-4	---	01-12-2017	01-11-2018
band rejection filter	Sinoscite	FL5CX01CA09C L12-0395-001	---	01-12-2017	01-11-2018
band rejection filter	Sinoscite	FL5CX01CA08C L12-0393-001	---	01-12-2017	01-11-2018
band rejection filter	Sinoscite	FL5CX02CA04C L12-0396-002	---	01-12-2017	01-11-2018
band rejection filter	Sinoscite	FL5CX02CA03C L12-0394-001	---	01-12-2017	01-11-2018
DC Power	Keysight	E3642A	MY54426112	03-14-2017	03-13-2018
DC Power	Keysight	E3642A	MY54426115	03-14-2017	03-13-2018
PC-2	Lenovo	R4960d	---	04-01-2017	03-31-2018
PC-3	Lenovo	R4960d	---	04-01-2017	03-31-2018
RF control unit	JS Tonscend	JS0806-1	158060004	03-14-2017	03-13-2018
DC power Box	JS Tonscend	JS0806-4	158060007	04-01-2017	03-31-2018
LTE Automatic test software	JS Tonscend	JS1120-1	---	04-01-2017	03-31-2018
WCDMA Automatic test software	JS Tonscend	JS1120-3	---	04-01-2017	03-31-2018
GSM Automatic test software	JS Tonscend	JS1120-3	---	04-01-2017	03-31-2018

Radiated Spurious Emission & Radiated Emission					
Equipment	Manufacturer	Mode No.	Serial Number	Cal. date (mm-dd-yyyy)	Cal. Due date (mm-dd-yyyy)
3M Chamber & Accessory Equipment	TDK	SAC-3	---	06-05-2016	06-05-2019
TRILOG Broadband Antenna	SCHWARZBECK	VULB9163	9163-618	07-28-2016	07-27-2017
Microwave Preamplifier	Agilent	8449B	3008A02425	02-16-2017	02-15-2018
Horn Antenna	ETS-LINDGREN	3117	00057407	07-20-2015	07-18-2018
Loop Antenna	ETS	6502	00071730	07-30-2015	07-28-2017
Spectrum Analyzer	R&S	FSP40	100416	06-16-2016	06-15-2017
Receiver	R&S	ESCI	100435	06-16-2016	06-15-2017
Multi device Controller	matureo	NCD/070/10711 112	---	01-12-2017	01-11-2018
LISN	schwarzbeck	NNBM8125	81251547	06-16-2016	06-15-2017
LISN	schwarzbeck	NNBM8125	81251548	06-16-2016	06-15-2017
Signal Generator	Agilent	E4438C	MY45095744	03-14-2017	03-13-2018
Signal Generator	Keysight	E8257D	MY53401106	03-14-2017	03-13-2018
Temperature/ Humidity Indicator	TAYLOR	1451	1905	05-08-2017	05-07-2018
Communication test set	Agilent	E5515C	GB47050534	03-14-2017	03-13-2018
Cable line	Fulai(7M)	SF106	5219/6A	01-12-2017	01-11-2018
Cable line	Fulai(6M)	SF106	5220/6A	01-12-2017	01-11-2018
Cable line	Fulai(3M)	SF106	5216/6A	01-12-2017	01-11-2018
Cable line	Fulai(3M)	SF106	5217/6A	01-12-2017	01-11-2018
Communication test set	R&S	CMW500	152394	03-14-2017	03-13-2018
High-pass filter(3-18GHz)	Sinoscite	FL3CX03WG18 NM12-0398-002	---	01-12-2017	01-11-2018
High-pass filter(6-18GHz)	MICRO-TRONICS	SPA-F-63029-4	---	01-12-2017	01-11-2018
band rejection filter	Sinoscite	FL5CX01CA09C L12-0395-001	---	01-12-2017	01-11-2018
band rejection filter	Sinoscite	FL5CX01CA08C L12-0393-001	---	01-12-2017	01-11-2018
band rejection filter	Sinoscite	FL5CX02CA04C L12-0396-002	---	01-12-2017	01-11-2018
band rejection filter	Sinoscite	FL5CX02CA03C L12-0394-001	---	01-12-2017	01-11-2018

8 Radio Technical Requirements Specification

Reference documents for testing:

No.	Identity	Document Title
1	PART 27 (2015)	PART 27 – MISCELLANEOUS WIRELESS COMMUNICATIONS SERVICES Subpart C – Technical Standards
2	PART 2 (2015)	Frequency allocations and radio treaty matters; general rules and regulations
3	TIA-603-D-2010	Land Mobile FM or PM -Communications Equipment -Measurement and Performance Standards
4	KDB971168 D01	KDB971168 D01 Power Meas License Digital Systems v02r02
5	KDB 412172 D01	KDB 412172 D01 Determining ERP and EIRP v01r01

Test Results List:

Test Requirement	Test method	Test item	Verdict	Note
Part 2.1046(a)/ Part 27.50(d)	TIA-603-D&KDB 971168 D01v02r02	Conducted output power	PASS	Appendix A)
Part 27.50(d)	KDB 971168 D01v02r02	peak-to-average ratio	PASS	Appendix B)
Part 2.1049(h)	Part 27.53(h) &KDB 971168 D01v02r02	99% & 26dB Occupied Bandwidth	PASS	Appendix C)
Part 2.1051/ Part 27.53(h)	Part 27.53(h) &KDB 971168 D01v02r02	Band Edge at antenna terminals	PASS	Appendix D)
Part 2.1051/ Part 2.1057/ Part 27.53(h)	TIA-603-D &KDB 971168 D01v02r02	Spurious emissions at antenna terminals	PASS	Appendix E)
Part 2.1055/ Part 27.54	TIA-603-D &KDB 971168 D01v02r02	Frequency stability	PASS	Appendix F)
Part 2.1053/ Part 2.1057/ Part 27.53(h)	TIA-603-D &KDB 971168 D01v02r02	Field strength of spurious radiation	PASS	Appendix G)
Part 2.1046(a)/ Part 27.50(d)	TIA-603-D &KDB 971168 D01v02r02	Effective Radiated Power of Transmitter(ERP)	PASS	Appendix A)

Appendix A: Conducted Output Power and Effective (Isotropic) Radiated Power

<p>Description of the Conducted Output Power Measurement and ERP/EIRP Measurement:</p>	<p>A system simulator was used to establish communication with the EUT. Its parameters were set to force the EUT transmitting at maximum output power. The measured power in the radio frequency on the transmitter output terminals shall be reported.</p> <p>According to KDB 412172 D01 Power Approach $EIRP = P_T + G_T - L_c$, $ERP = EIRP - 2.15$, where</p> <p>P_T = transmitter output power in dBm G_T = gain of the transmitting antenna in dBi L_c = signal attenuation in the connecting cable between the transmitter and antenna in dB</p>				
<p>Measurement Procedure:</p>	<ol style="list-style-type: none"> 1. The transmitter output port was connected to the system simulator. 2. Set EUT at maximum power through the system simulator. 3. Select lowest, middle, and highest channels for each band and different modulation. 4. Measure and record the power level from the system simulator. 				
<p>Limit:</p>	<table border="1"> <tr> <td data-bbox="424 826 600 869">Mode</td> <td data-bbox="600 826 1058 869">LTE band 4</td> </tr> <tr> <td data-bbox="424 869 600 911">Limit</td> <td data-bbox="600 869 1058 911">30dBm (1W)</td> </tr> </table>	Mode	LTE band 4	Limit	30dBm (1W)
Mode	LTE band 4				
Limit	30dBm (1W)				

Test Result

$G_T - L_C = 2.5\text{dB}$

Channel Bandwidth: 1.4 MHz

Channel Bandwidth: 1.4 MHz							
Modulation	Channel	RB Configuration		Average Power [dBm]	E.i.r.p [dBm]	Verdict	
		Size	Offset				
QPSK	LCH	1	0	23.70	26.20	PASS	
		1	3	23.90	26.40	PASS	
		1	5	23.87	26.37	PASS	
		3	0	22.63	25.13	PASS	
		3	2	22.66	25.16	PASS	
		3	3	22.62	25.12	PASS	
		6	0	22.72	25.22	PASS	
	MCH	1	0	23.51	26.01	PASS	
		1	3	23.48	25.98	PASS	
		1	5	23.30	25.80	PASS	
		3	0	22.58	25.08	PASS	
		3	2	22.52	25.02	PASS	
		3	3	22.46	24.96	PASS	
		6	0	22.51	25.01	PASS	
	HCH	1	0	23.53	26.03	PASS	
		1	3	23.61	26.11	PASS	
		1	5	23.40	25.90	PASS	
		3	0	22.45	24.95	PASS	
		3	2	22.51	25.01	PASS	
		3	3	22.63	25.13	PASS	
		6	0	22.52	25.02	PASS	
	16QAM	LCH	1	0	23.48	25.98	PASS
			1	3	23.61	26.11	PASS
			1	5	23.49	25.99	PASS
3			0	22.94	25.44	PASS	
3			2	22.86	25.36	PASS	
3			3	22.91	25.41	PASS	
MCH		6	0	21.61	24.11	PASS	
		1	0	23.22	25.72	PASS	
		1	3	23.20	25.70	PASS	
		1	5	23.08	25.58	PASS	
		3	0	22.79	25.29	PASS	
		3	2	22.79	25.29	PASS	

		3	3	22.55	25.05	PASS
		6	0	21.85	24.35	PASS
	HCH	1	0	23.19	25.69	PASS
		1	3	23.44	25.94	PASS
		1	5	23.29	25.79	PASS
		3	0	22.37	24.87	PASS
		3	2	22.46	24.96	PASS
		3	3	22.39	24.89	PASS
		6	0	21.47	23.97	PASS

Channel Bandwidth: 3 MHz

Channel Bandwidth: 3 MHz							
Modulation	Channel	RB Configuration		Average Power [dBm]	E.i.r.p [dBm]	Verdict	
		Size	Offset				
QPSK	LCH	1	0	23.68	26.18	PASS	
		1	7	23.74	26.24	PASS	
		1	14	23.95	26.45	PASS	
		8	0	22.82	25.32	PASS	
		8	4	22.90	25.40	PASS	
		8	7	22.83	25.33	PASS	
		15	0	22.73	25.23	PASS	
	MCH	1	0	23.46	25.96	PASS	
		1	7	23.29	25.79	PASS	
		1	14	23.57	26.07	PASS	
		8	0	22.63	25.13	PASS	
		8	4	22.45	24.95	PASS	
		8	7	22.32	24.82	PASS	
		15	0	22.53	25.03	PASS	
	HCH	1	0	23.34	25.84	PASS	
		1	7	23.52	26.02	PASS	
		1	14	23.74	26.24	PASS	
		8	0	22.34	24.84	PASS	
		8	4	22.39	24.89	PASS	
		8	7	22.46	24.96	PASS	
		15	0	22.46	24.96	PASS	
	16QAM	LCH	1	0	23.14	25.64	PASS
			1	7	23.54	26.04	PASS
			1	14	23.35	25.85	PASS
			8	0	21.86	24.36	PASS

		8	4	21.97	24.47	PASS
		8	7	21.96	24.46	PASS
		15	0	21.57	24.07	PASS
	MCH	1	0	23.43	25.93	PASS
		1	7	23.19	25.69	PASS
		1	14	23.00	25.50	PASS
		8	0	21.81	24.31	PASS
		8	4	21.69	24.19	PASS
		8	7	21.53	24.03	PASS
		15	0	21.57	24.07	PASS
	HCH	1	0	22.56	25.06	PASS
		1	7	22.97	25.47	PASS
		1	14	23.24	25.74	PASS
		8	0	21.15	23.65	PASS
		8	4	21.21	23.71	PASS
8		7	21.27	23.77	PASS	
15		0	21.40	23.90	PASS	

Channel Bandwidth: 5 MHz

Channel Bandwidth: 5 MHz						
Modulation	Channel	RB Configuration		Average Power [dBm]	E.i.r.p [dBm]	Verdict
		Size	Offset			
QPSK	LCH	1	0	23.52	26.02	PASS
		1	12	23.68	26.18	PASS
		1	24	23.90	26.40	PASS
		12	0	22.70	25.20	PASS
		12	6	22.75	25.25	PASS
		12	13	22.86	25.36	PASS
		25	0	22.88	25.38	PASS
	MCH	1	0	23.61	26.11	PASS
		1	12	23.25	25.75	PASS
		1	24	23.36	25.86	PASS
		12	0	22.65	25.15	PASS
		12	6	22.52	25.02	PASS
		12	13	22.35	24.85	PASS
		25	0	22.56	25.06	PASS
	HCH	1	0	23.33	25.83	PASS
		1	12	23.45	25.95	PASS
		1	24	23.73	26.23	PASS

16QAM		12	0	22.40	24.90	PASS
		12	6	22.49	24.99	PASS
		12	13	22.51	25.01	PASS
		25	0	22.39	24.89	PASS
	LCH	1	0	22.87	25.37	PASS
		1	12	22.61	25.11	PASS
		1	24	23.08	25.58	PASS
		12	0	21.90	24.40	PASS
		12	6	21.95	24.45	PASS
		12	13	21.79	24.29	PASS
		25	0	21.93	24.43	PASS
	MCH	1	0	22.26	24.76	PASS
		1	12	22.04	24.54	PASS
		1	24	22.41	24.91	PASS
		12	0	21.55	24.05	PASS
		12	6	21.37	23.87	PASS
		12	13	21.20	23.70	PASS
		25	0	21.63	24.13	PASS
	HCH	1	0	22.59	25.09	PASS
		1	12	22.42	24.92	PASS
		1	24	22.78	25.28	PASS
		12	0	21.38	23.88	PASS
		12	6	21.24	23.74	PASS
		12	13	21.38	23.88	PASS
		25	0	21.47	23.97	PASS

Channel Bandwidth: 10 MHz

Channel Bandwidth: 10 MHz						
Modulation	Channel	RB Configuration		Average Power [dBm]	E.i.r.p [dBm]	Verdict
		Size	Offset			
QPSK	LCH	1	0	23.72	26.22	PASS
		1	24	23.90	26.40	PASS
		1	49	23.84	26.34	PASS
		25	0	22.86	25.36	PASS
		25	12	22.76	25.26	PASS
		25	25	22.81	25.31	PASS
		50	0	22.92	25.42	PASS
	MCH	1	0	23.90	26.40	PASS
		1	24	23.37	25.87	PASS

		1	49	23.02	25.52	PASS		
		25	0	22.76	25.26	PASS		
		25	12	22.58	25.08	PASS		
		25	25	22.20	24.70	PASS		
		50	0	22.55	25.05	PASS		
	HCH	1	0	23.07	25.57	PASS		
		1	24	23.52	26.02	PASS		
		1	49	23.67	26.17	PASS		
		25	0	22.18	24.68	PASS		
		25	12	22.35	24.85	PASS		
		25	25	22.44	24.94	PASS		
		50	0	22.23	24.73	PASS		
		16QAM	LCH	1	0	23.02	25.52	PASS
				1	24	23.09	25.59	PASS
	1			49	23.75	26.25	PASS	
25	0			21.71	24.21	PASS		
25	12			21.92	24.42	PASS		
25	25			21.90	24.40	PASS		
50	0			22.00	24.50	PASS		
MCH	1		0	23.63	26.13	PASS		
	1		24	23.10	25.60	PASS		
	1		49	22.61	25.11	PASS		
	25	0	21.60	24.10	PASS			
	25	12	21.30	23.80	PASS			
	25	25	21.08	23.58	PASS			
	50	0	21.48	23.98	PASS			
HCH	1	0	22.68	25.18	PASS			
	1	24	23.06	25.56	PASS			
	1	49	23.50	26.00	PASS			
	25	0	21.15	23.65	PASS			
	25	12	21.16	23.66	PASS			
	25	25	21.35	23.85	PASS			
	50	0	21.20	23.70	PASS			

Channel Bandwidth: 15 MHz

Channel Bandwidth: 15 MHz						
Modulation	Channel	RB Configuration		Average Power [dBm]	E.i.r.p [dBm]	Verdict
		Size	Offset			
QPSK	LCH	1	0	23.81	26.31	PASS
		1	37	23.88	26.38	PASS
		1	74	23.78	26.28	PASS
		37	0	22.91	25.41	PASS
		37	18	22.10	24.60	PASS
		37	38	22.34	24.84	PASS
		75	0	22.16	24.66	PASS
	MCH	1	0	23.18	25.68	PASS
		1	37	23.33	25.83	PASS
		1	74	23.02	25.52	PASS
		37	0	22.75	25.25	PASS
		37	18	22.43	24.93	PASS
		37	38	22.06	24.56	PASS
		75	0	22.53	25.03	PASS
	HCH	1	0	23.18	25.68	PASS
		1	37	23.19	25.69	PASS
		1	74	23.62	26.12	PASS
		37	0	22.06	24.56	PASS
		37	18	22.20	24.70	PASS
		37	38	22.34	24.84	PASS
		75	0	22.15	24.65	PASS
16QAM	LCH	1	0	23.32	25.82	PASS
		1	37	23.42	25.92	PASS
		1	74	23.83	26.33	PASS
		37	0	21.75	24.25	PASS
		37	18	22.04	24.54	PASS
		37	38	22.30	24.80	PASS
		75	0	22.22	24.72	PASS
	MCH	1	0	23.84	26.34	PASS
		1	37	22.60	25.10	PASS
		1	74	22.31	24.81	PASS
		37	0	21.79	24.29	PASS
		37	18	21.31	23.81	PASS
		37	38	21.08	23.58	PASS
		75	0	21.61	24.11	PASS

HCH	1	0	22.57	25.07	PASS
	1	37	22.28	24.78	PASS
	1	74	23.52	26.02	PASS
	37	0	20.92	23.42	PASS
	37	18	21.04	23.54	PASS
	37	38	21.30	23.80	PASS
	75	0	21.23	23.73	PASS

Channel Bandwidth: 20 MHz

Channel Bandwidth: 20 MHz							
Modulation	Channel	RB Configuration		Average Power [dBm]	E.i.r.p [dBm]	Verdict	
		Size	Offset				
QPSK	LCH	1	0	23.86	26.36	PASS	
		1	49	23.46	25.96	PASS	
		1	99	23.30	25.80	PASS	
		50	0	22.97	25.47	PASS	
		50	25	22.22	24.72	PASS	
		50	50	22.12	24.62	PASS	
		100	0	22.08	24.58	PASS	
	MCH	1	0	23.22	25.72	PASS	
		1	49	23.43	25.93	PASS	
		1	99	22.86	25.36	PASS	
		50	0	22.95	25.45	PASS	
		50	25	22.56	25.06	PASS	
		50	50	22.04	24.54	PASS	
		100	0	22.39	24.89	PASS	
	HCH	1	0	23.46	25.96	PASS	
		1	49	23.18	25.68	PASS	
		1	99	23.96	26.46	PASS	
		50	0	22.19	24.69	PASS	
		50	25	22.27	24.77	PASS	
		50	50	22.22	24.72	PASS	
		100	0	22.14	24.64	PASS	
	16QAM	LCH	1	0	22.41	24.91	PASS
			1	49	23.35	25.85	PASS
			1	99	22.49	24.99	PASS
50			0	21.87	24.37	PASS	
50			25	22.20	24.70	PASS	
50			50	22.20	24.70	PASS	

		100	0	21.94	24.44	PASS
	MCH	1	0	23.53	26.03	PASS
		1	49	22.47	24.97	PASS
		1	99	21.46	23.96	PASS
		50	0	21.91	24.41	PASS
		50	25	21.54	24.04	PASS
		50	50	21.00	23.50	PASS
		100	0	21.43	23.93	PASS
		HCH	1	0	22.74	25.24
	1		49	21.75	24.25	PASS
	1		99	22.44	24.94	PASS
	50		0	21.32	23.82	PASS
	50		25	21.28	23.78	PASS
	50		50	21.25	23.75	PASS
	100		0	21.15	23.65	PASS

Appendix B: Peak-to-Average Ratio

Test Result

Channel Bandwidth: 1.4 MHz

Channel Bandwidth: 1.4 MHz							
Modulation	Channel	RB Configuration		Peak-to-Average Ratio (dB)	Limit (dB)	Verdict	
		Size	Offset				
QPSK	LCH	1	0	4.98	<13	PASS	
		1	3	4.87	<13	PASS	
		1	5	4.99	<13	PASS	
		3	0	5.13	<13	PASS	
		3	2	5.03	<13	PASS	
		3	3	5.15	<13	PASS	
	MCH	6	0	5.46	<13	PASS	
		1	0	5.11	<13	PASS	
		1	3	5	<13	PASS	
		1	5	5.08	<13	PASS	
		3	0	5.25	<13	PASS	
		3	2	11.99	<13	PASS	
		3	3	5.26	<13	PASS	
		6	0	5.58	<13	PASS	
	HCH	1	0	4.83	<13	PASS	
		1	3	4.68	<13	PASS	
		1	5	4.88	<13	PASS	
		3	0	4.91	<13	PASS	
		3	2	4.85	<13	PASS	
		3	3	4.88	<13	PASS	
		6	0	5.47	<13	PASS	
		16QAM	LCH	1	0	5.7	<13
	1			3	5.67	<13	PASS
	1			5	5.74	<13	PASS
3	0			5.99	<13	PASS	
3	2			5.94	<13	PASS	
3	3			6.01	<13	PASS	
MCH	6		0	6.41	<13	PASS	
	1		0	5.38	<13	PASS	
	1		3	5.8	<13	PASS	
	1		5	5.82	<13	PASS	
	3		0	6.2	<13	PASS	
	3		2	6.08	<13	PASS	

		3	3	6.17	<13	PASS
		6	0	6.44	<13	PASS
	HCH	1	0	5.53	<13	PASS
		1	3	5.45	<13	PASS
		1	5	5.48	<13	PASS
		3	0	5.83	<13	PASS
		3	2	5.73	<13	PASS
		3	3	5.85	<13	PASS
		6	0	6.3	<13	PASS

Channel Bandwidth: 3 MHz

Channel Bandwidth: 3 MHz							
Modulation	Channel	RB Configuration		Peak-to-Average Ratio [dB]	Limit [dB]	Verdict	
		Size	Offset				
QPSK	LCH	1	0	4.88	<13	PASS	
		1	7	4.73	<13	PASS	
		1	14	4.88	<13	PASS	
		8	0	5.14	<13	PASS	
		8	4	5.08	<13	PASS	
		8	7	5.17	<13	PASS	
		15	0	5.44	<13	PASS	
	MCH	1	0	5.08	<13	PASS	
		1	7	4.95	<13	PASS	
		1	14	5.09	<13	PASS	
		8	0	5.28	<13	PASS	
		8	4	5.25	<13	PASS	
		8	7	5.27	<13	PASS	
		15	0	5.59	<13	PASS	
	HCH	1	0	8.48	<13	PASS	
		1	7	4.7	<13	PASS	
		1	14	4.81	<13	PASS	
		8	0	5.3	<13	PASS	
		8	4	5.25	<13	PASS	
		8	7	5.33	<13	PASS	
		15	0	5.67	<13	PASS	
	16QAM	LCH	1	0	5.5	<13	PASS
			1	7	5.5	<13	PASS
			1	14	5.68	<13	PASS
			8	0	6	<13	PASS

		8	4	5.96	<13	PASS
		8	7	6.02	<13	PASS
		15	0	6.37	<13	PASS
	MCH	1	0	5.79	<13	PASS
		1	7	5.77	<13	PASS
		1	14	5.83	<13	PASS
		8	0	6.13	<13	PASS
		8	4	6.09	<13	PASS
		8	7	6.15	<13	PASS
		15	0	6.5	<13	PASS
	HCH	1	0	5.74	<13	PASS
		1	7	5.62	<13	PASS
		1	14	5.64	<13	PASS
		8	0	6.17	<13	PASS
		8	4	6.13	<13	PASS
8		7	6.18	<13	PASS	
15		0	6.57	<13	PASS	

Channel Bandwidth: 5 MHz

Channel Bandwidth: 5 MHz						
Modulation	Channel	RB Configuration		Peak-to-Average Ratio [dB]	Limit [dB]	Verdict
		Size	Offset			
QPSK	LCH	1	0	4.9	<13	PASS
		1	12	4.83	<13	PASS
		1	24	4.99	<13	PASS
		12	0	5.28	<13	PASS
		12	6	5.08	<13	PASS
		12	13	5.26	<13	PASS
		25	0	5.66	<13	PASS
	MCH	1	0	4.99	<13	PASS
		1	12	4.92	<13	PASS
		1	24	4.99	<13	PASS
		12	0	5.38	<13	PASS
		12	6	5.18	<13	PASS
		12	13	5.34	<13	PASS
		25	0	5.74	<13	PASS
	HCH	1	0	4.86	<13	PASS
		1	12	4.79	<13	PASS
		1	24	4.89	<13	PASS

16QAM	LCH	12	0	5.33	<13	PASS	
		12	6	5.28	<13	PASS	
		12	13	5.29	<13	PASS	
		25	0	5.68	<13	PASS	
	MCH	LCH	1	0	5.58	<13	PASS
			1	12	5.72	<13	PASS
			1	24	5.73	<13	PASS
			12	0	6.15	<13	PASS
			12	6	5.94	<13	PASS
			12	13	8.45	<13	PASS
		MCH	25	0	6.4	<13	PASS
			1	0	5.79	<13	PASS
			1	12	5.77	<13	PASS
			1	24	5.75	<13	PASS
			12	0	6.27	<13	PASS
			12	6	6.05	<13	PASS
	HCH	12	13	6.24	<13	PASS	
		25	0	6.48	<13	PASS	
		1	0	5.7	<13	PASS	
		1	12	5.6	<13	PASS	
		1	24	5.59	<13	PASS	
		12	0	6.17	<13	PASS	
		12	6	6.14	<13	PASS	
		12	13	6.19	<13	PASS	
	25	0	6.4	<13	PASS		

Channel Bandwidth: 10 MHz

Channel Bandwidth: 10 MHz						
Modulation	Channel	RB Configuration		Peak-to-Average Ratio [dB]	Limit [dB]	Verdict
		Size	Offset			
QPSK	LCH	1	0	4.93	<13	PASS
		1	24	4.88	<13	PASS
		1	49	5	<13	PASS
		25	0	5.02	<13	PASS
		25	12	5.39	<13	PASS
		25	25	4.99	<13	PASS
		50	0	5.23	<13	PASS
	MCH	1	0	4.99	<13	PASS
		1	24	4.95	<13	PASS

		1	49	5.02	<13	PASS		
		25	0	5.1	<13	PASS		
		25	12	5.25	<13	PASS		
		25	25	5.08	<13	PASS		
		50	0	5.26	<13	PASS		
	HCH	1	0	4.89	<13	PASS		
		1	24	4.76	<13	PASS		
		1	49	4.84	<13	PASS		
		25	0	5.01	<13	PASS		
		25	12	5.36	<13	PASS		
		25	25	5	<13	PASS		
		50	0	5.25	<13	PASS		
		16QAM	LCH	1	0	5.68	<13	PASS
				1	24	5.7	<13	PASS
				1	49	5.75	<13	PASS
25	0			6.07	<13	PASS		
25	12			6.08	<13	PASS		
25	25			6.12	<13	PASS		
50	0			6.27	<13	PASS		
MCH	1			0	5.77	<13	PASS	
	1		24	5.61	<13	PASS		
	1		49	5.88	<13	PASS		
	25		0	6.18	<13	PASS		
	25		12	8.48	<13	PASS		
	25		25	6.13	<13	PASS		
	50		0	6.31	<13	PASS		
HCH	1		0	5.67	<13	PASS		
	1	24	5.47	<13	PASS			
	1	49	5.43	<13	PASS			
	25	0	6.05	<13	PASS			
	25	12	8.46	<13	PASS			
	25	25	6.13	<13	PASS			
	50	0	6.3	<13	PASS			

Channel Bandwidth: 15 MHz

Channel Bandwidth: 15 MHz							
Modulation	Channel	RB Configuration		Peak-to-Average Ratio [dB]	Limit [dB]	Verdict	
		Size	Offset				
QPSK	LCH	1	0	5.87	<13	PASS	
		1	37	4.9	<13	PASS	
		1	74	6.32	<13	PASS	
		37	0	5.27	<13	PASS	
		37	18	5.53	<13	PASS	
		37	38	5.41	<13	PASS	
		75	0	5.47	<13	PASS	
	MCH	1	0	6.02	<13	PASS	
		1	37	4.98	<13	PASS	
		1	74	6.33	<13	PASS	
		37	0	5.31	<13	PASS	
		37	18	5.5	<13	PASS	
		37	38	5.38	<13	PASS	
		75	0	5.41	<13	PASS	
		HCH	1	0	6.04	<13	PASS
			1	37	4.78	<13	PASS
			1	74	6.27	<13	PASS
	37		0	5.26	<13	PASS	
	37		18	5.45	<13	PASS	
	37		38	5.39	<13	PASS	
	75		0	8.57	<13	PASS	
	16QAM	LCH	1	0	6.79	<13	PASS
			1	37	5.78	<13	PASS
			1	74	6.83	<13	PASS
37			0	6.45	<13	PASS	
37			18	6.22	<13	PASS	
37			38	6.49	<13	PASS	
75			0	6.6	<13	PASS	
MCH		1	0	6.76	<13	PASS	
		1	37	5.81	<13	PASS	
		1	74	7.02	<13	PASS	
		37	0	6.49	<13	PASS	
		37	18	6.32	<13	PASS	
		37	38	6.45	<13	PASS	
		75	0	6.68	<13	PASS	

HCH	1	0	6.75	<13	PASS
	1	37	5.59	<13	PASS
	1	74	6.76	<13	PASS
	37	0	6.42	<13	PASS
	37	18	6.24	<13	PASS
	37	38	6.5	<13	PASS
	75	0	6.55	<13	PASS

Channel Bandwidth: 20 MHz

Channel Bandwidth: 20 MHz							
Modulation	Channel	RB Configuration		Peak-to-Average Ratio [dB]	Limit [dB]	Verdict	
		Size	Offset				
QPSK	LCH	1	0	4.3	<13	PASS	
		1	49	4.82	<13	PASS	
		1	99	4.01	<13	PASS	
		50	0	5.98	<13	PASS	
		50	25	5.18	<13	PASS	
		50	50	6.31	<13	PASS	
		100	0	6.04	<13	PASS	
	MCH	1	0	4.31	<13	PASS	
		1	49	4.85	<13	PASS	
		1	99	4.18	<13	PASS	
		50	0	5.99	<13	PASS	
		50	25	5.12	<13	PASS	
		50	50	6.29	<13	PASS	
		100	0	6.09	<13	PASS	
	HCH	1	0	3.93	<13	PASS	
		1	49	4.67	<13	PASS	
		1	99	3.29	<13	PASS	
		50	0	5.94	<13	PASS	
		50	25	5.06	<13	PASS	
		50	50	6.29	<13	PASS	
		100	0	6.06	<13	PASS	
	16QAM	LCH	1	0	4.66	<13	PASS
			1	49	5.44	<13	PASS
			1	99	4.47	<13	PASS
			50	0	6.86	<13	PASS
			50	25	6.32	<13	PASS
			50	50	6.93	<13	PASS

		100	0	7.09	<13	PASS
	MCH	1	0	3.99	<13	PASS
		1	49	5.54	<13	PASS
		1	99	4.83	<13	PASS
		50	0	6.88	<13	PASS
		50	25	6.25	<13	PASS
		50	50	6.96	<13	PASS
		100	0	7.05	<13	PASS
		HCH	1	0	3.85	<13
	1		49	5.51	<13	PASS
	1		99	3.83	<13	PASS
	50		0	6.84	<13	PASS
	50		25	6.21	<13	PASS
	50		50	6.94	<13	PASS
	100		0	6.98	<13	PASS

Test Graphs

Channel Bandwidth: 1.4 MHz

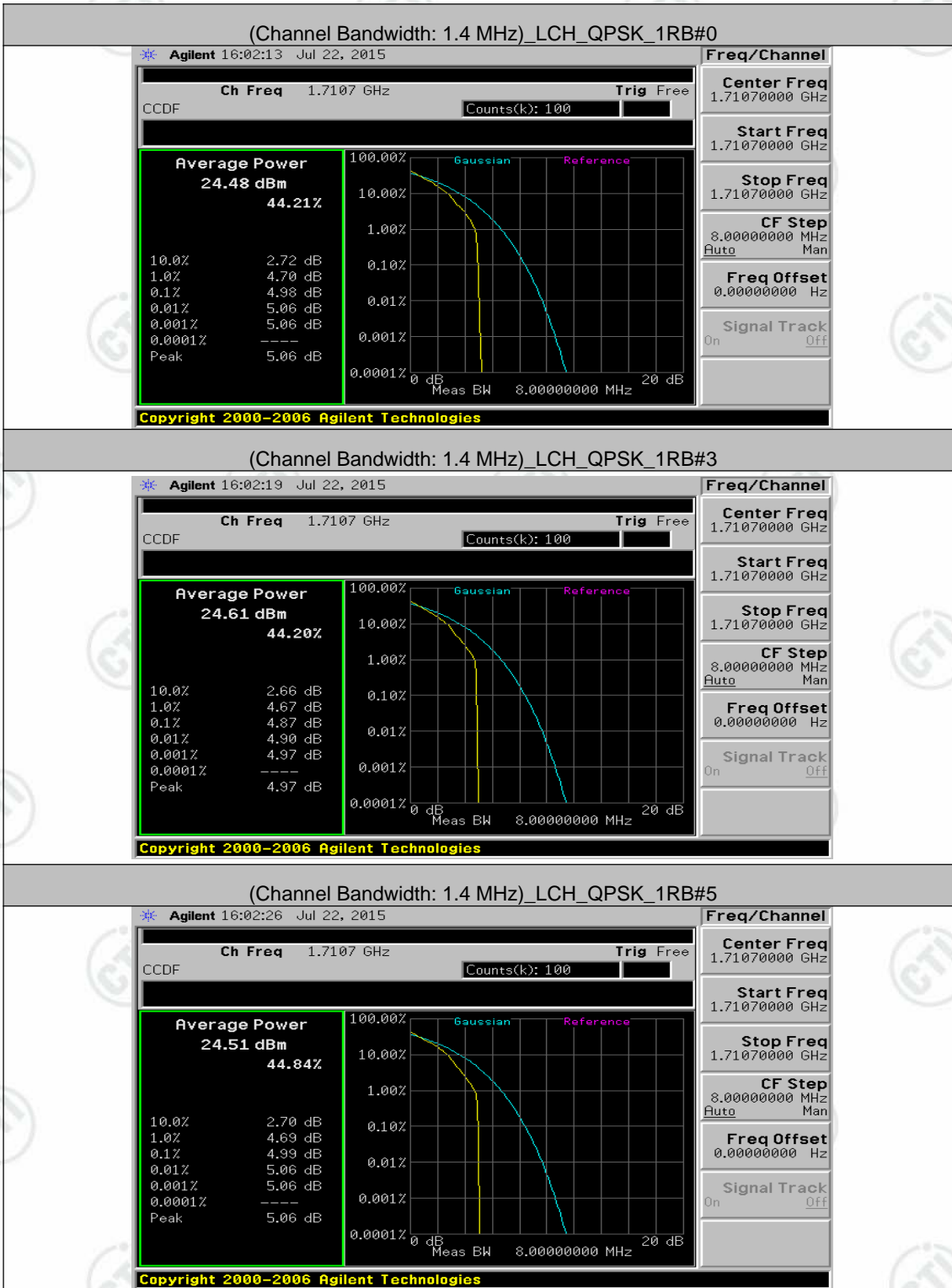



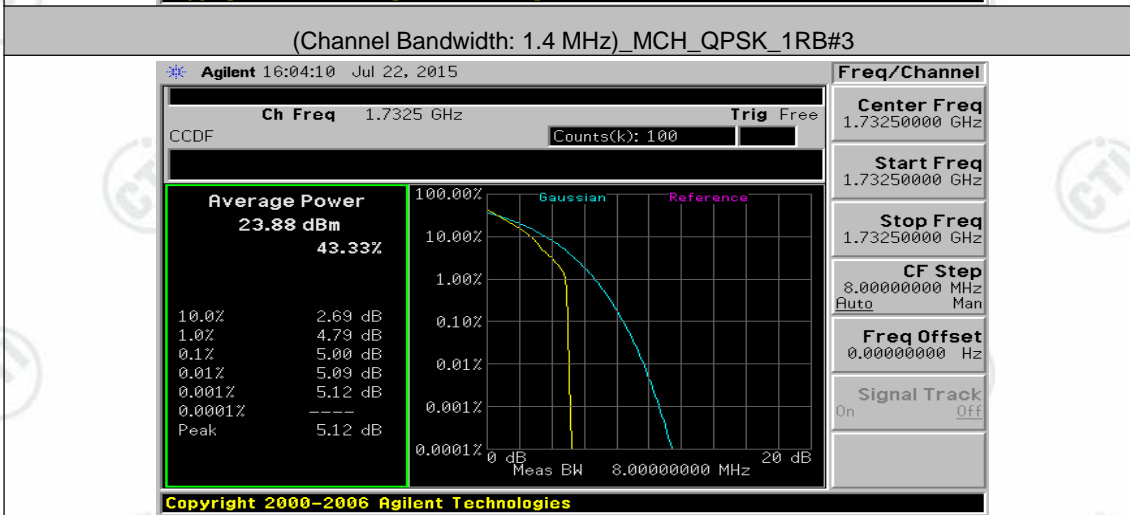
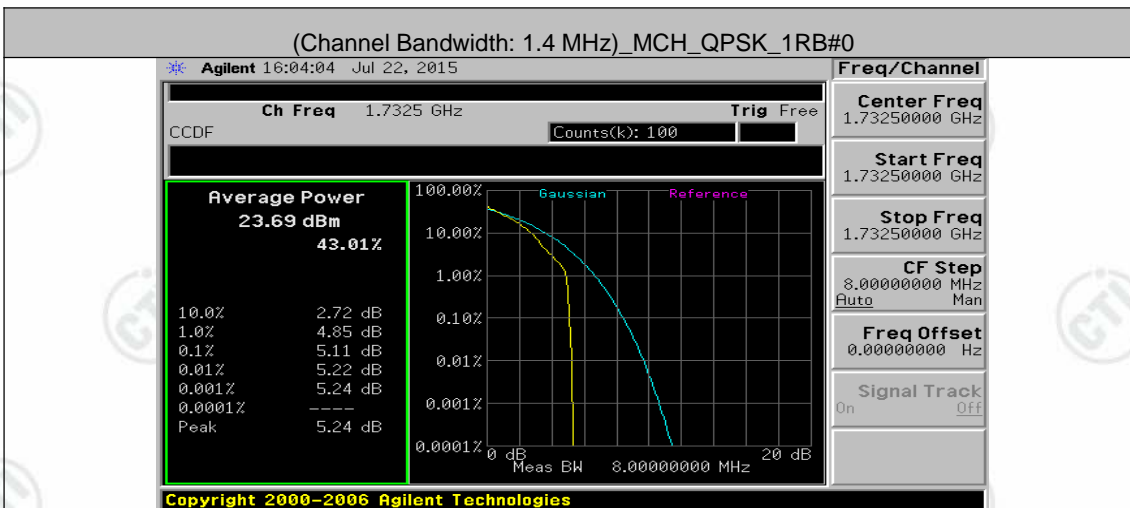
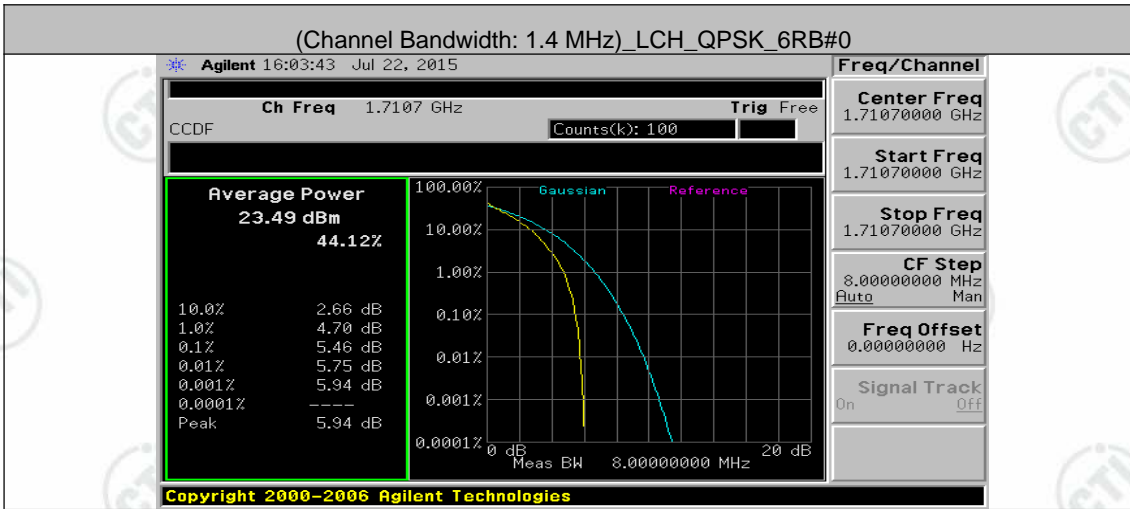



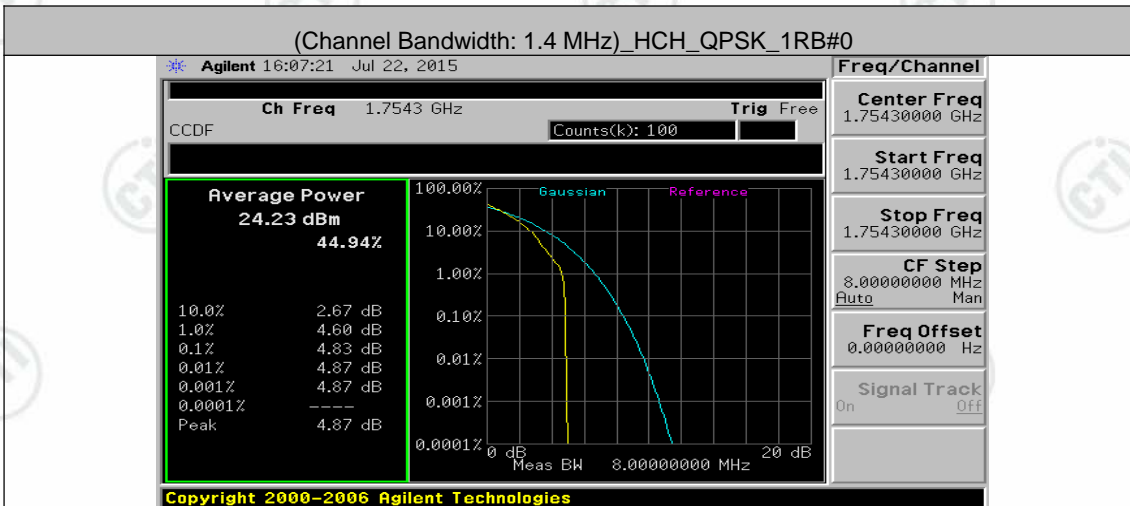
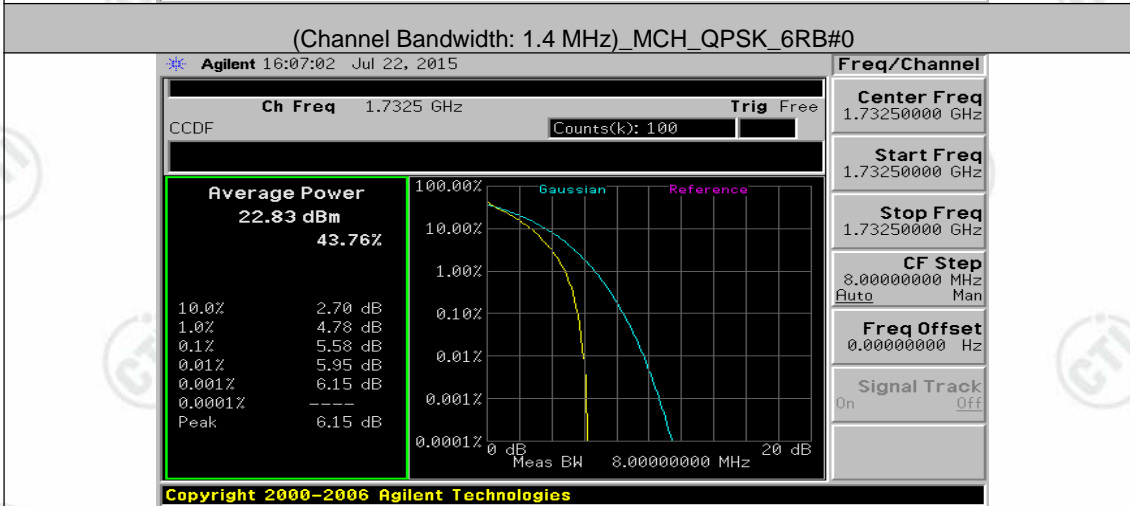
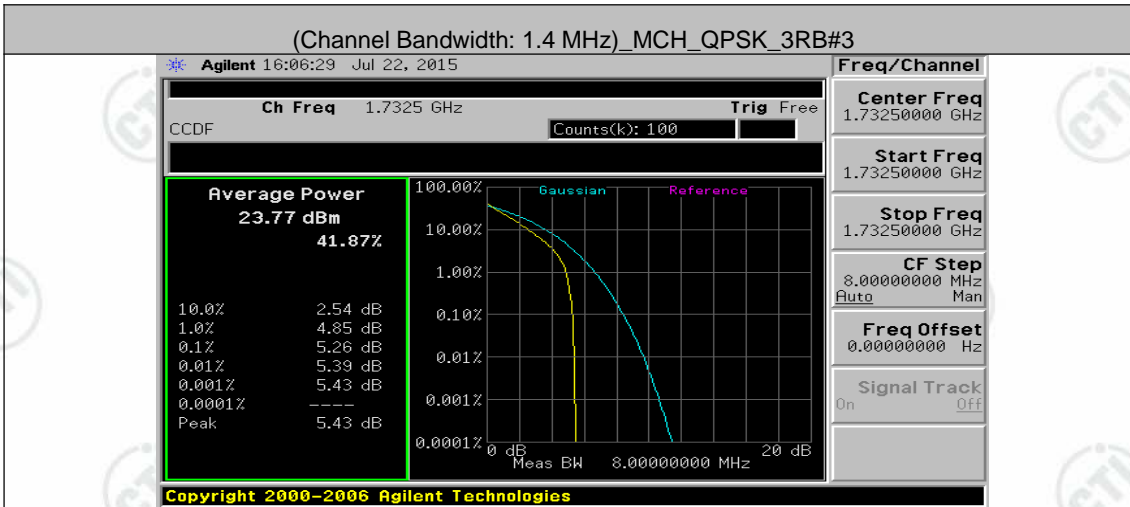

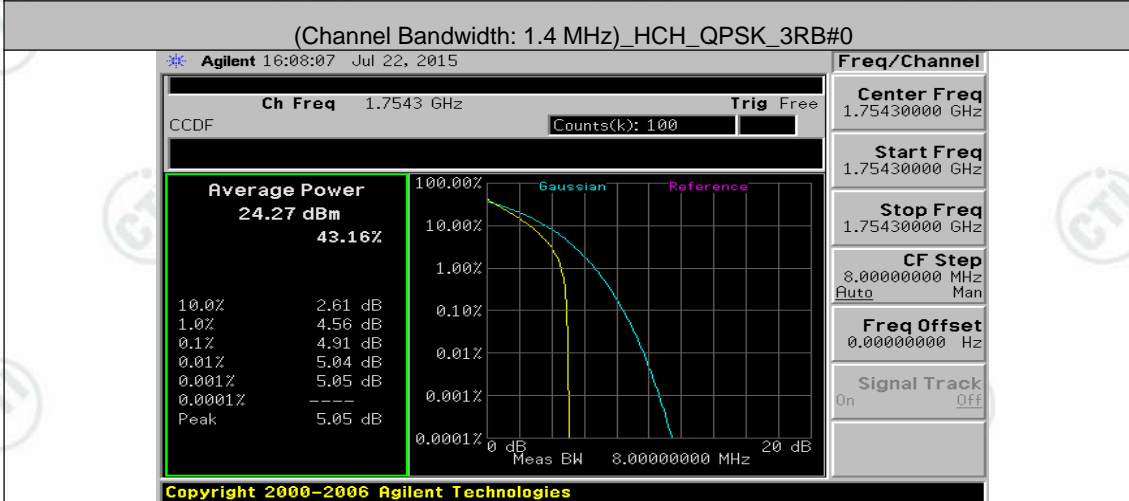
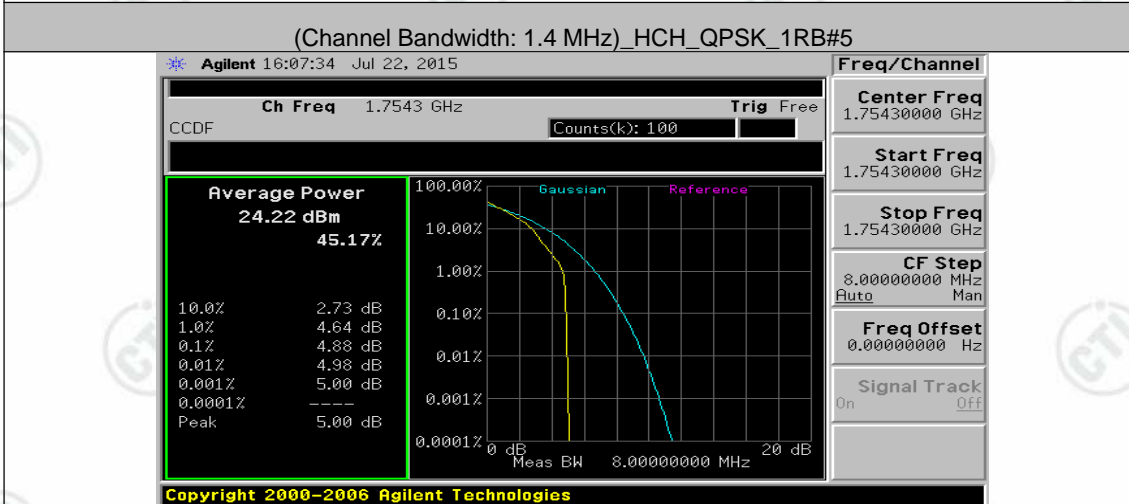
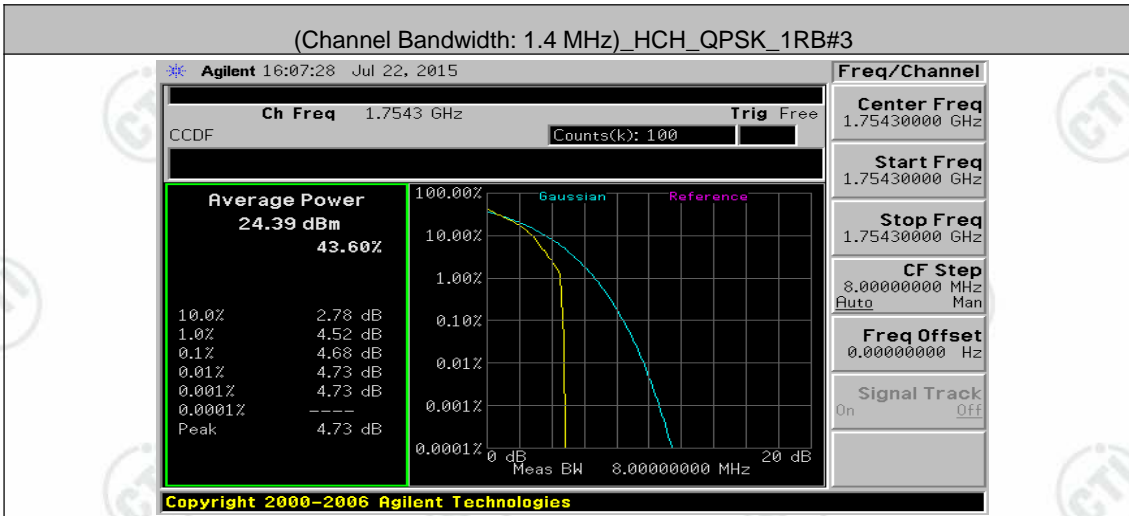

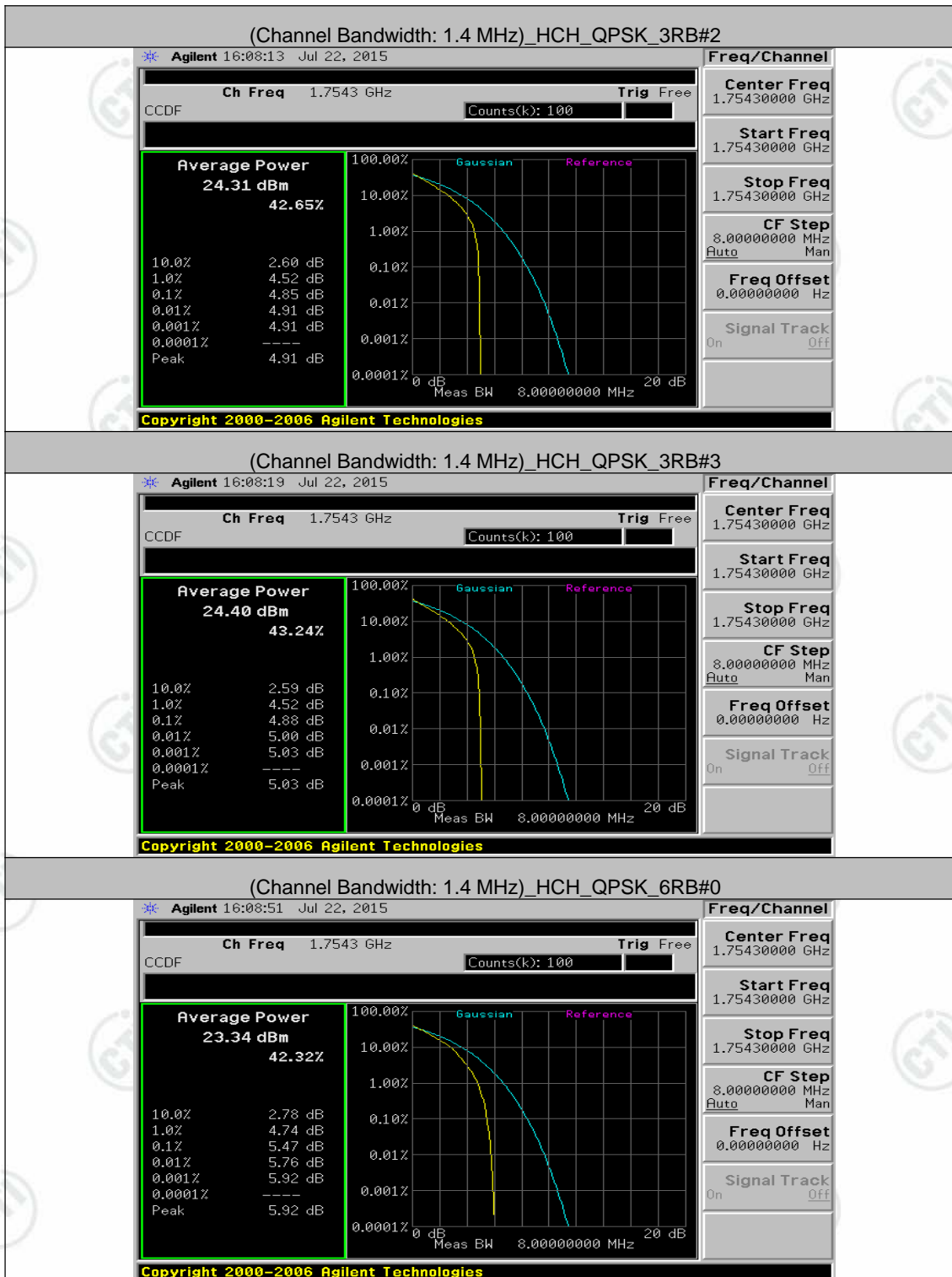

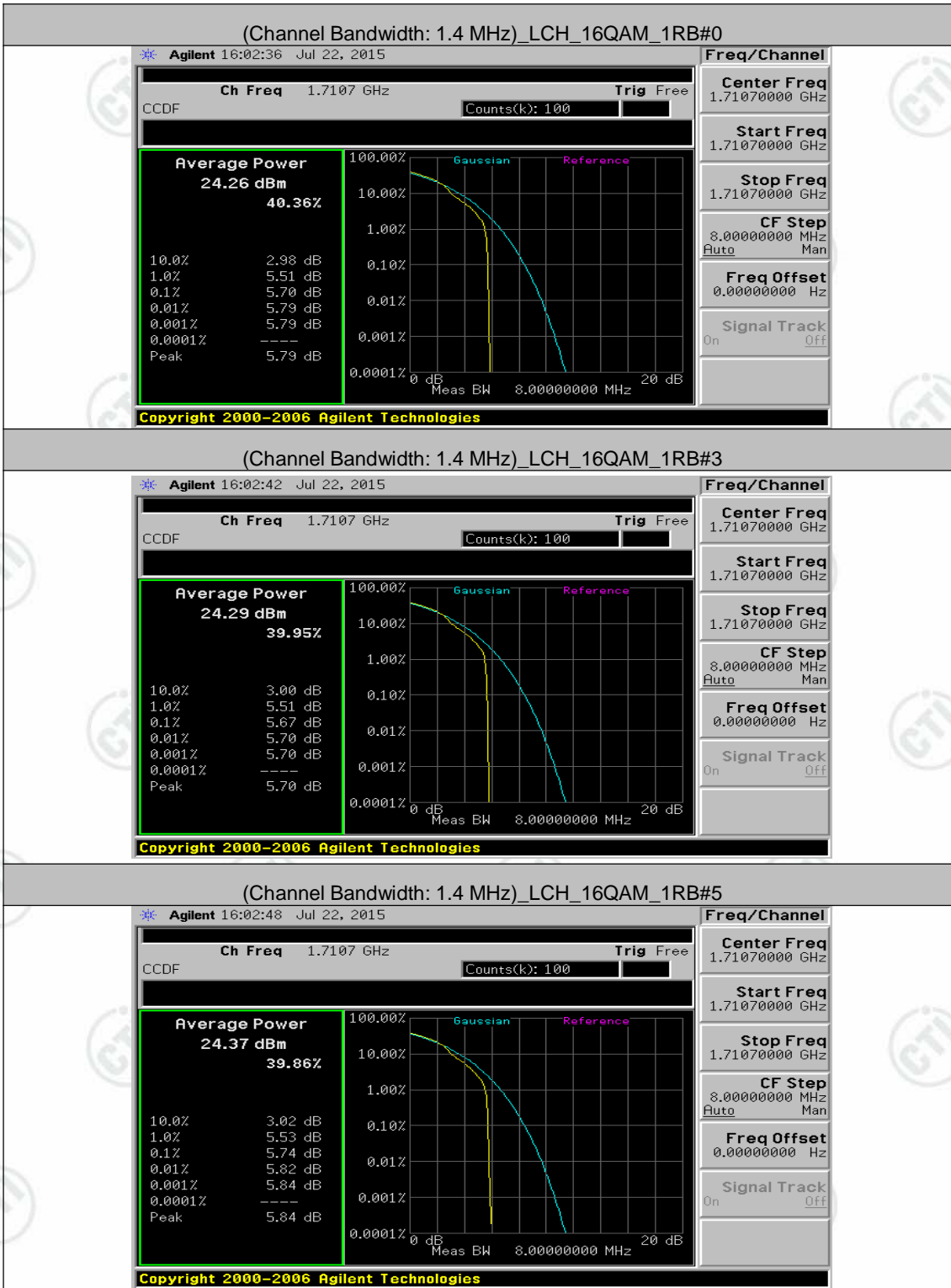

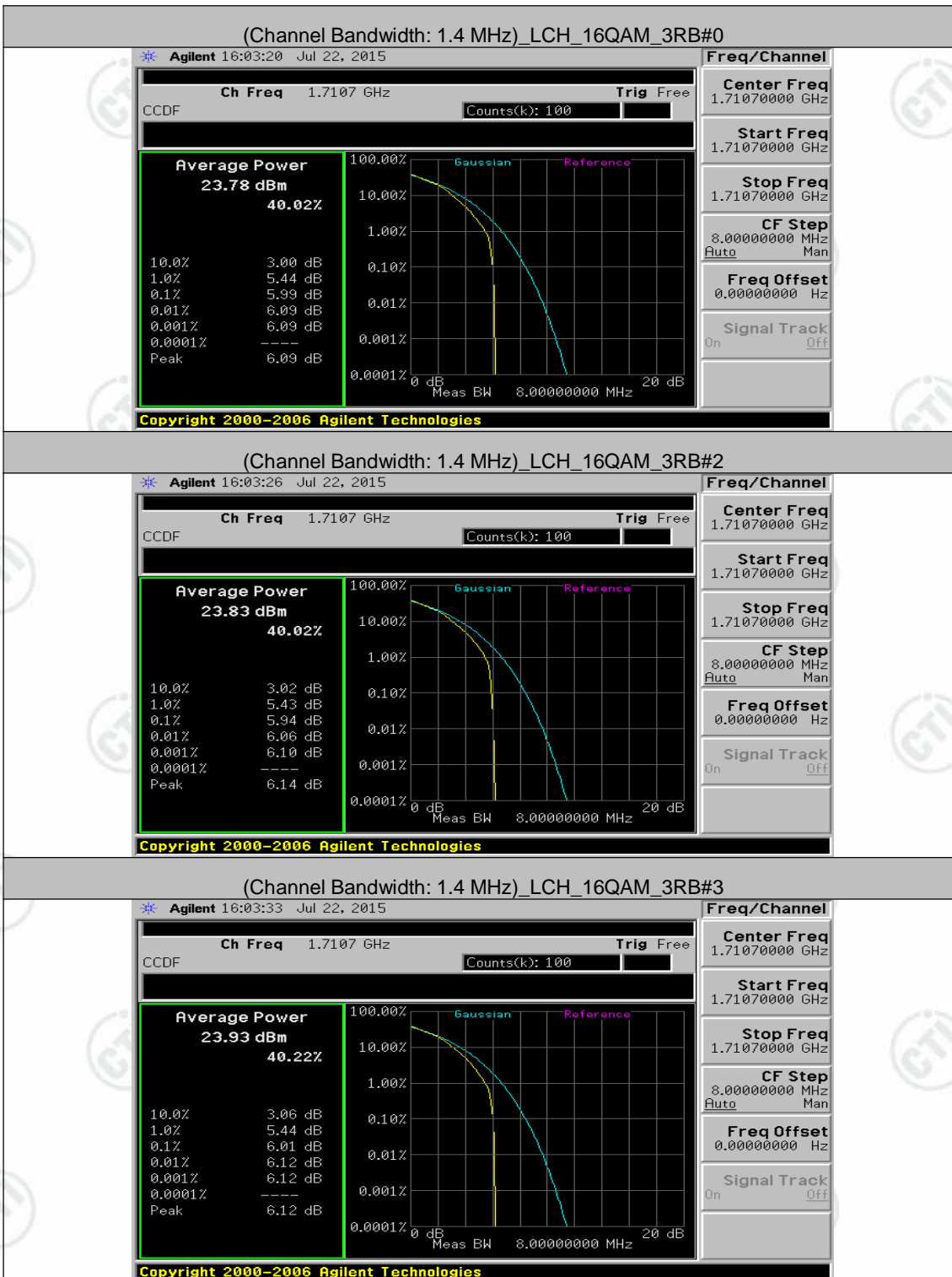

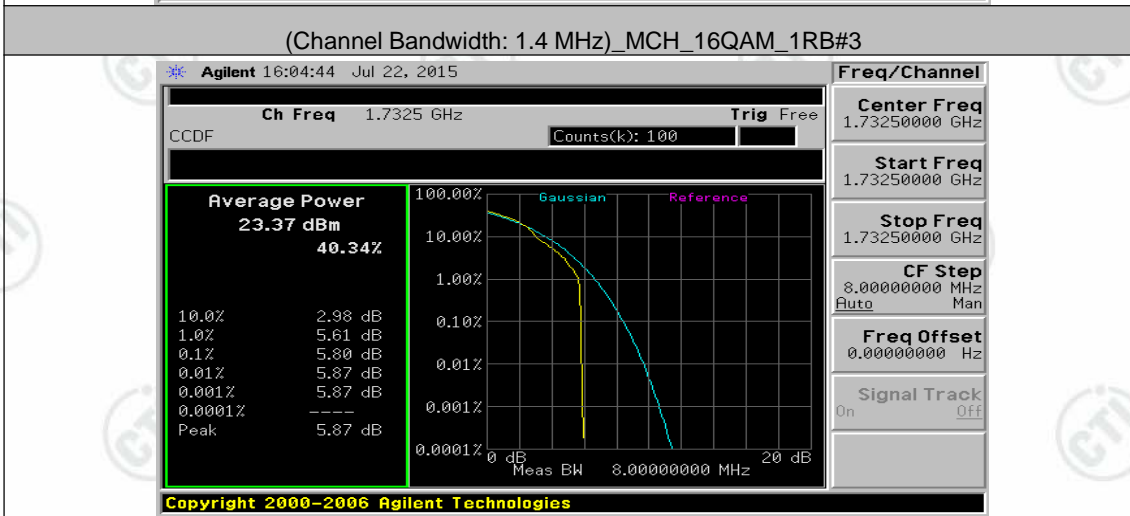
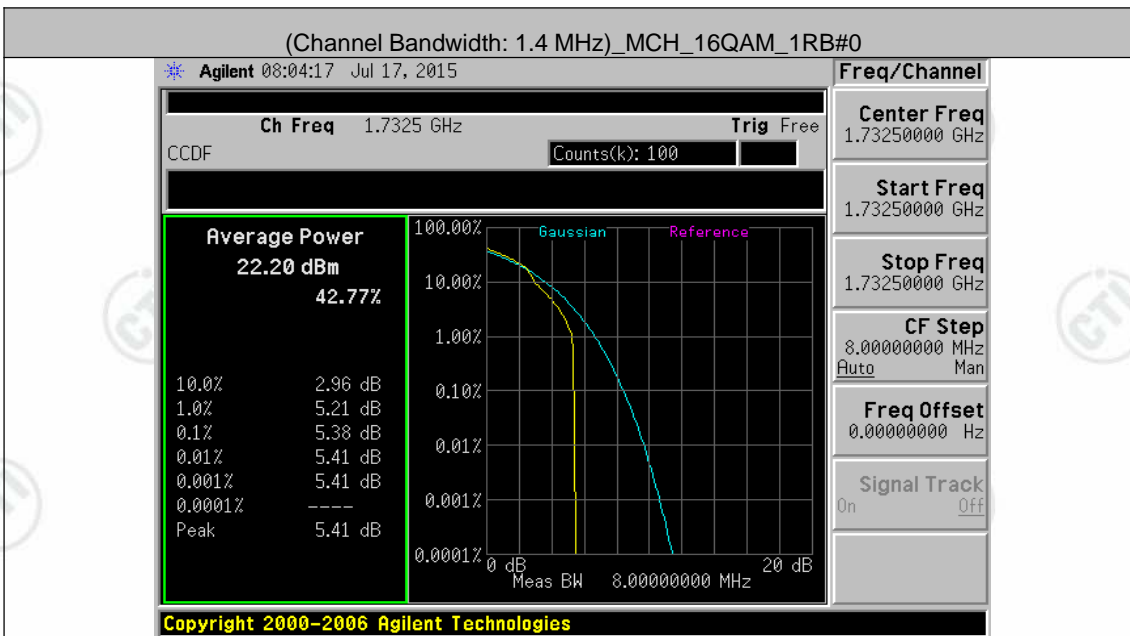
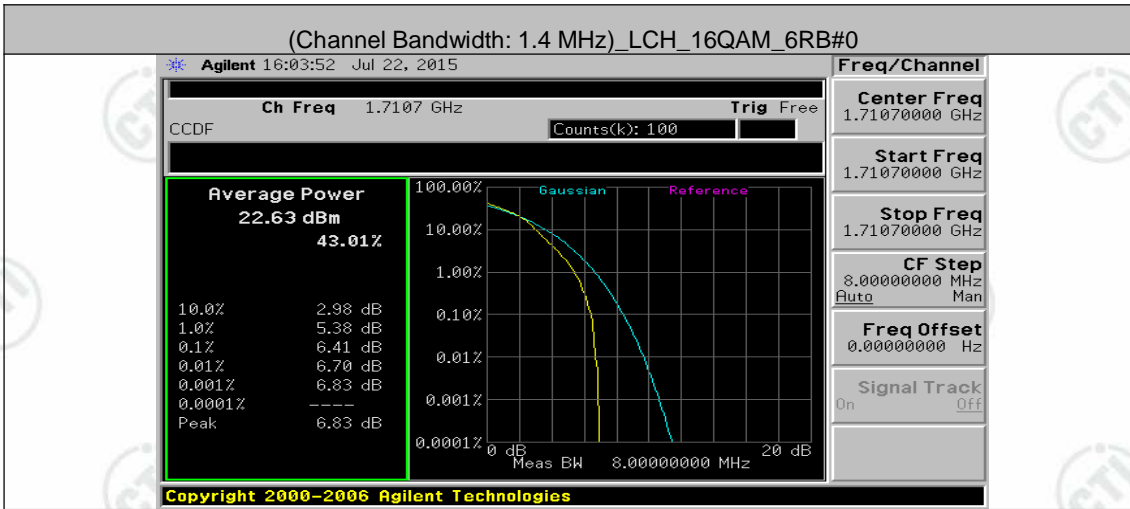



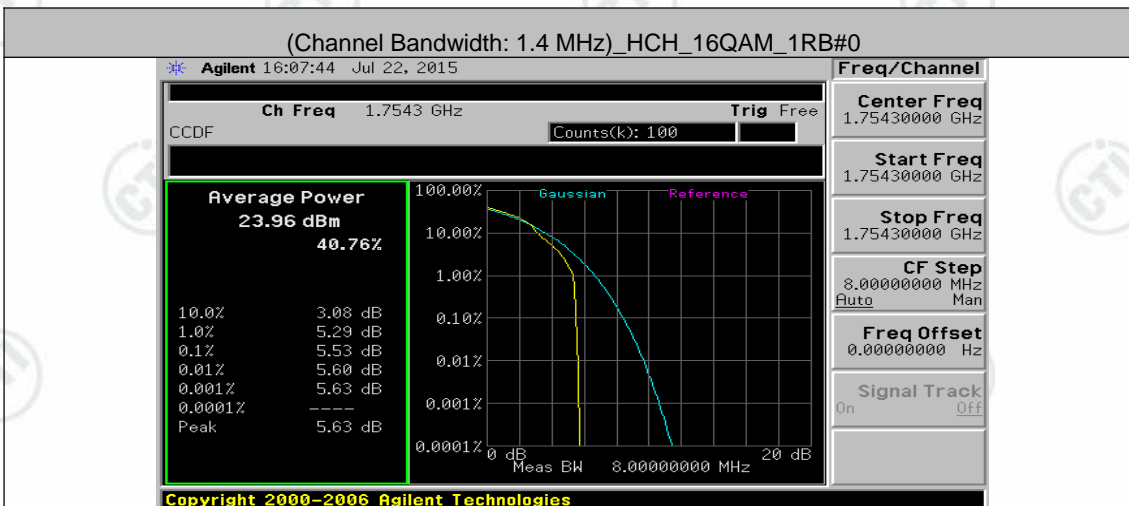
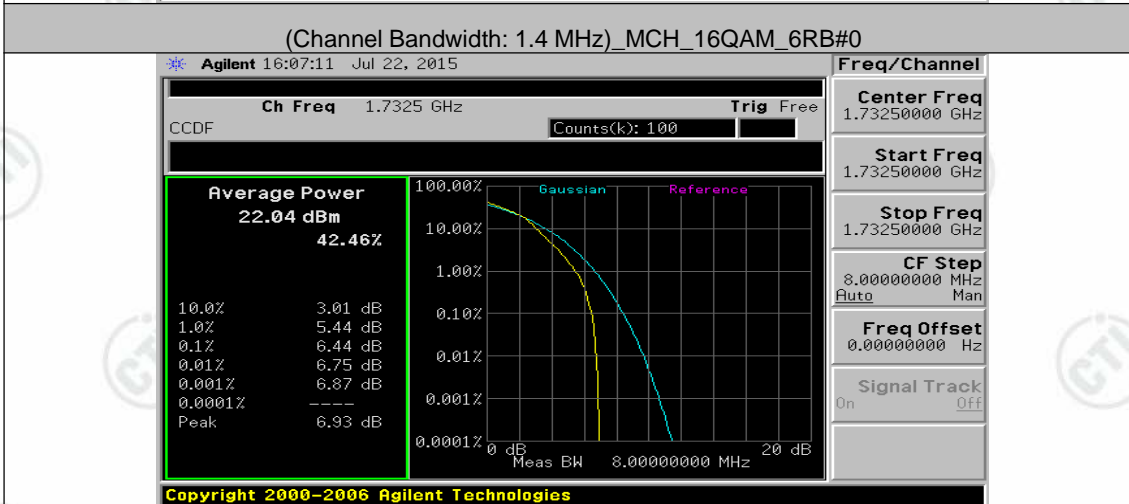
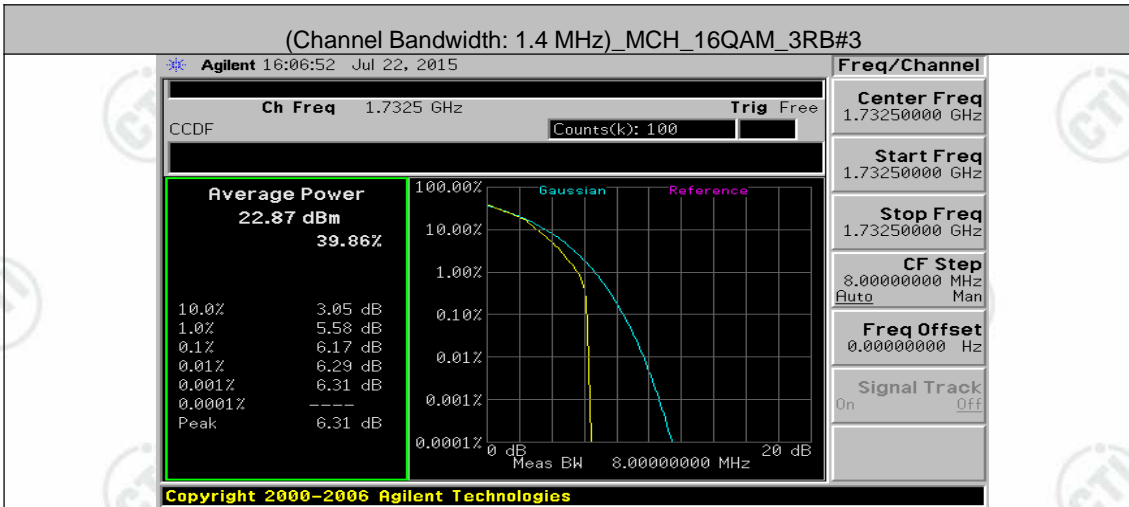

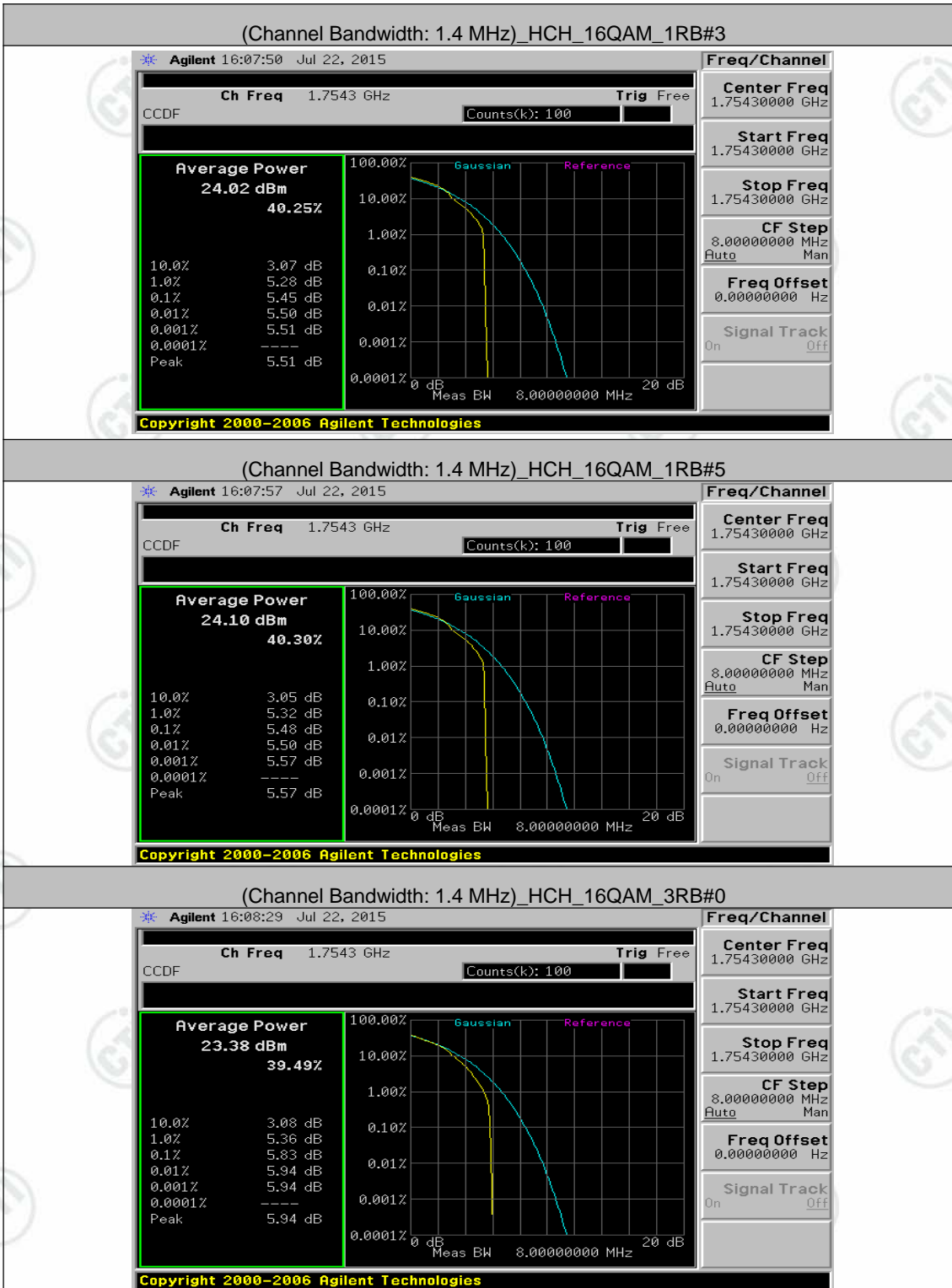

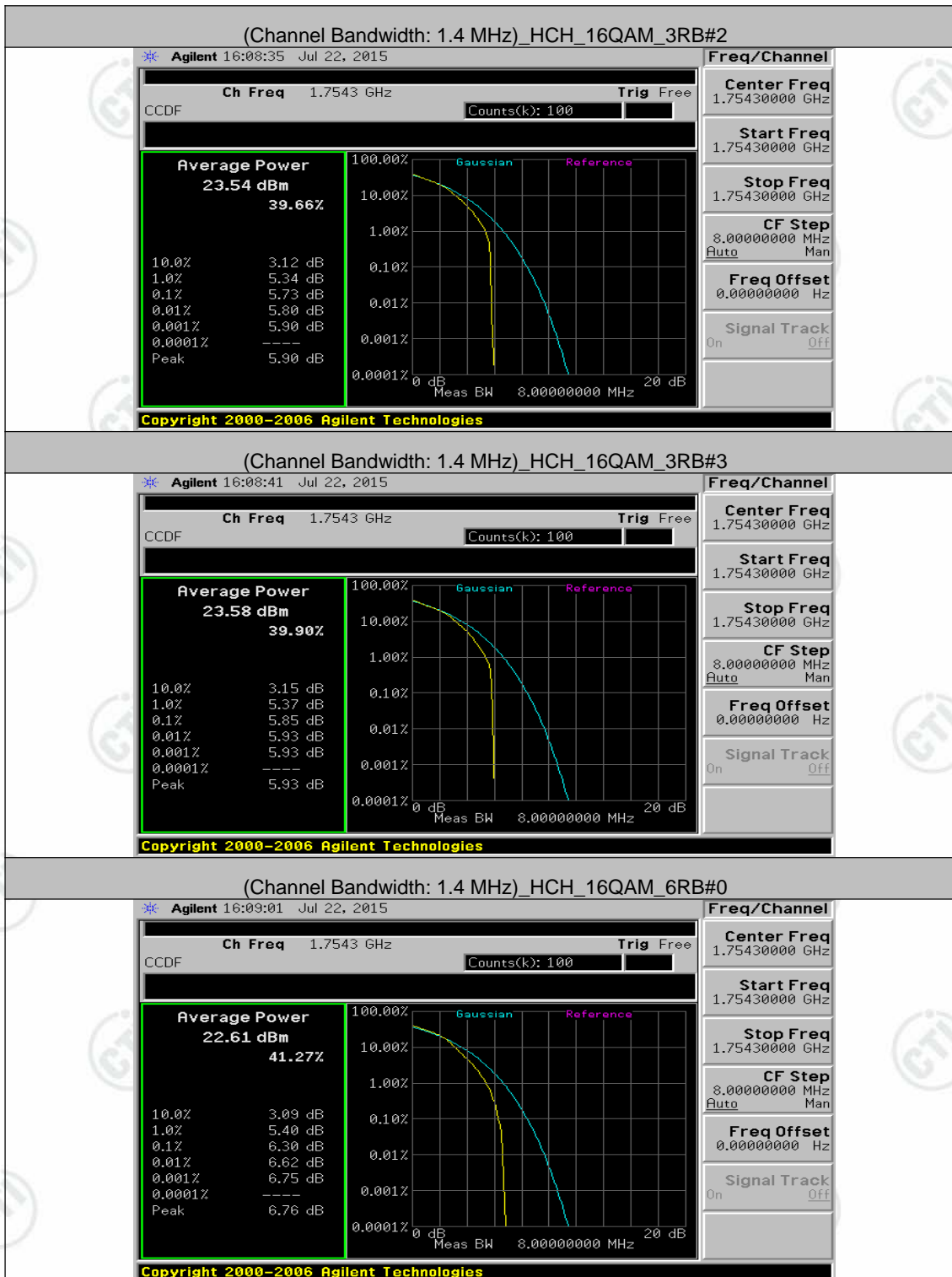

Channel Bandwidth: 3 MHz





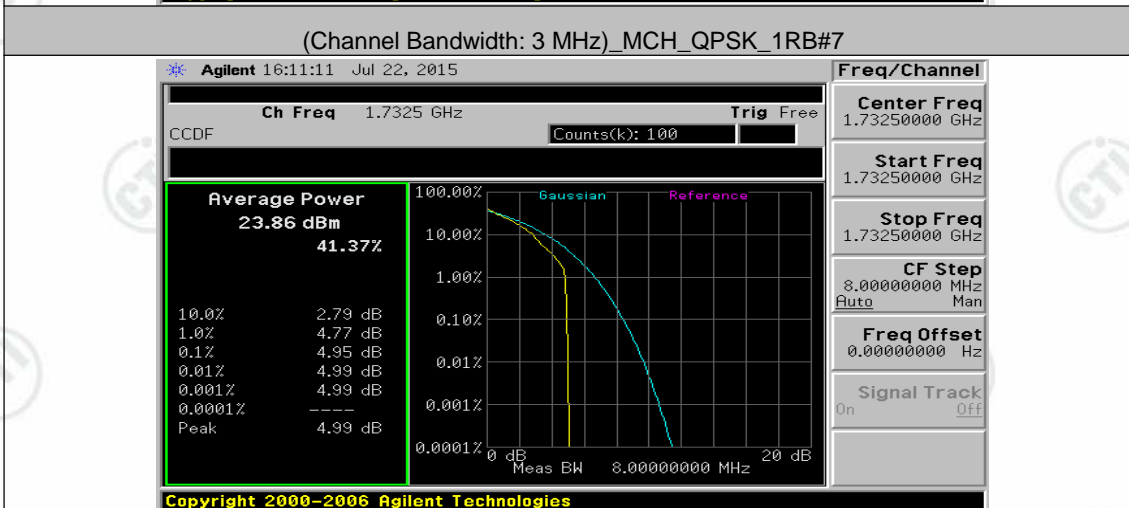
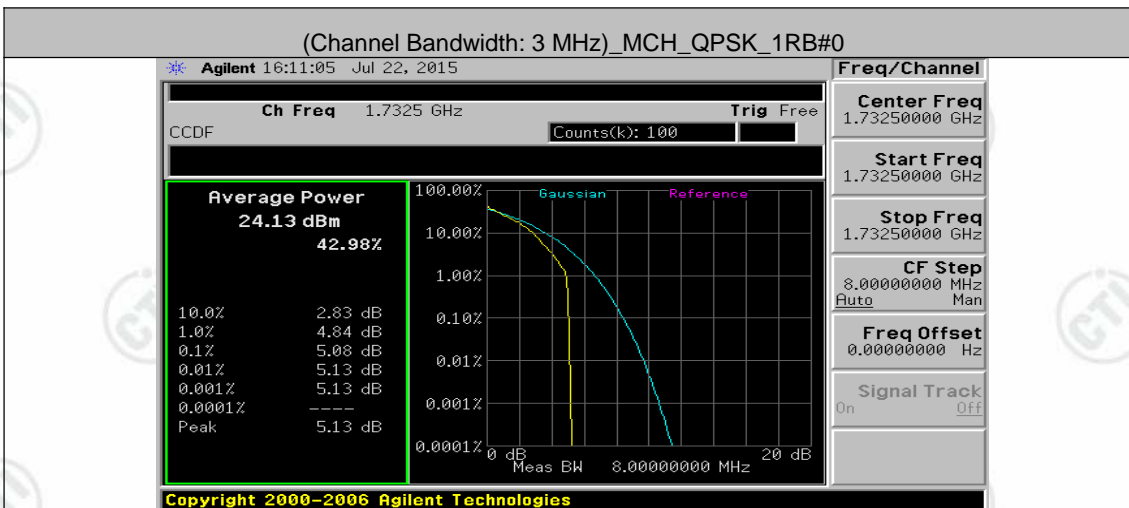
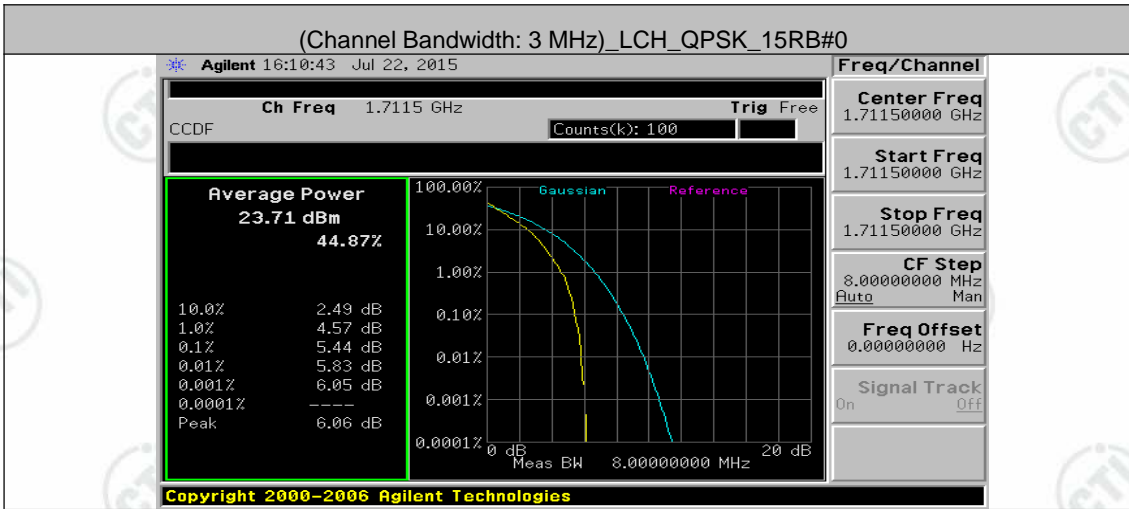

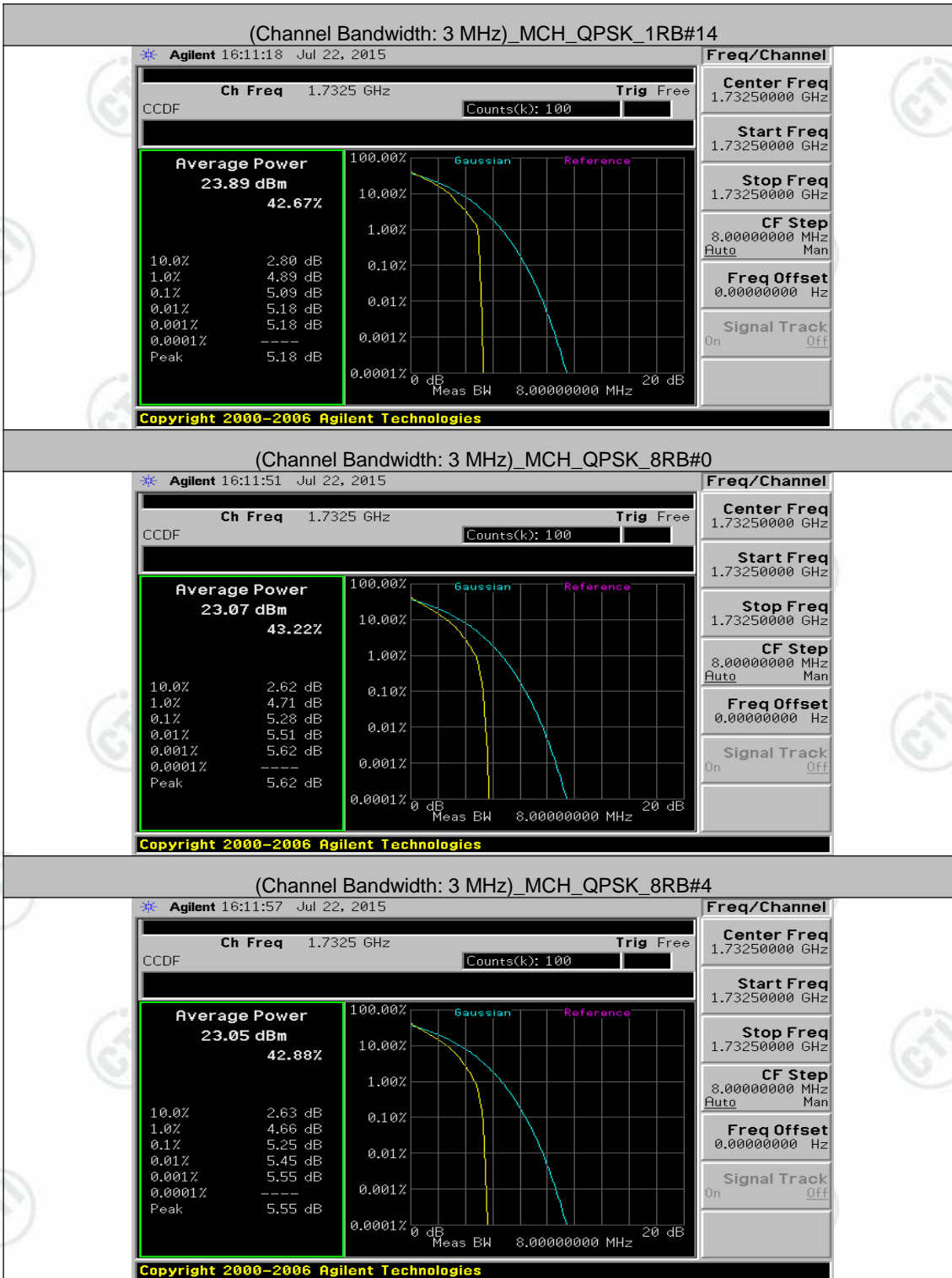

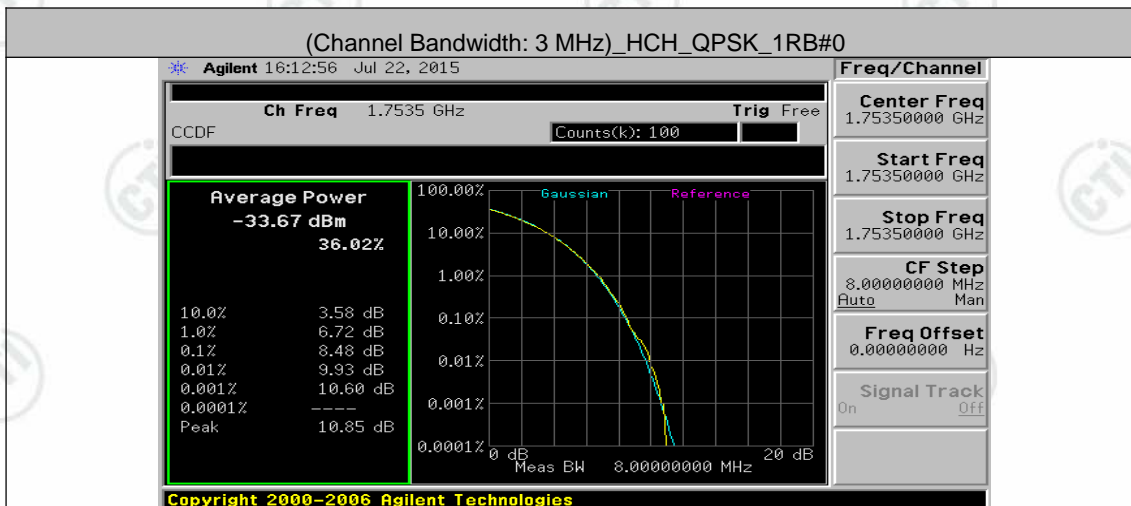
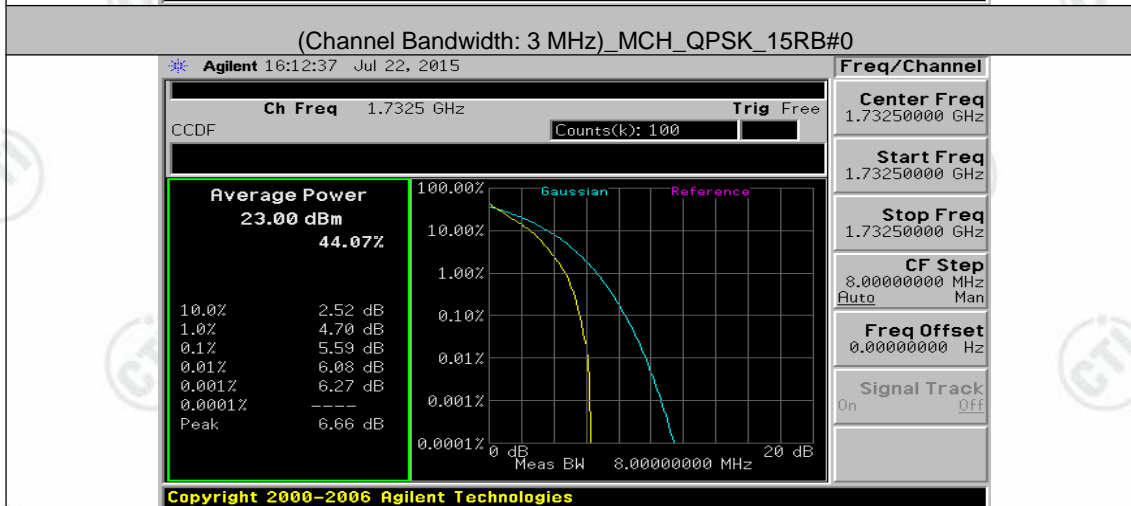
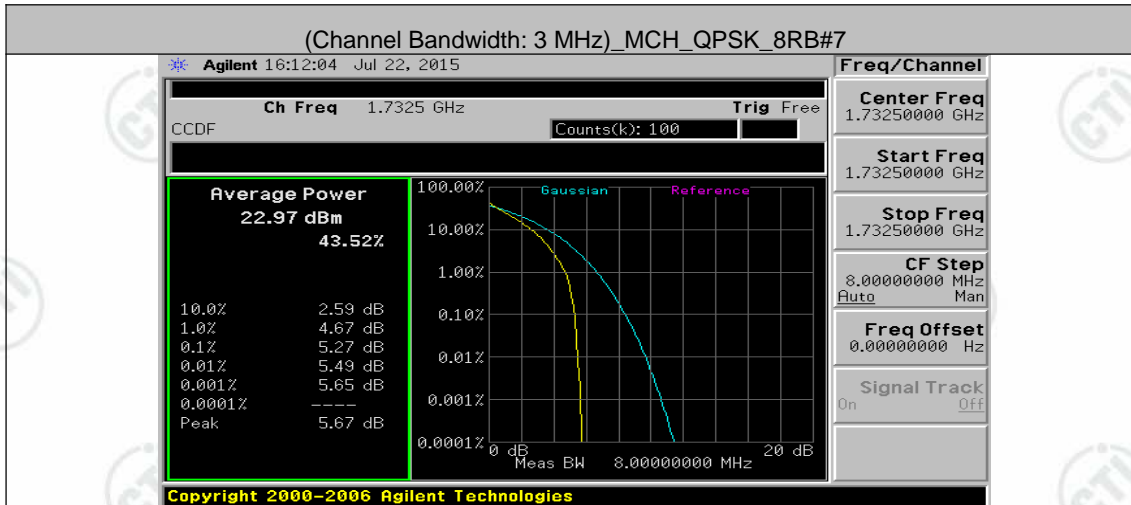









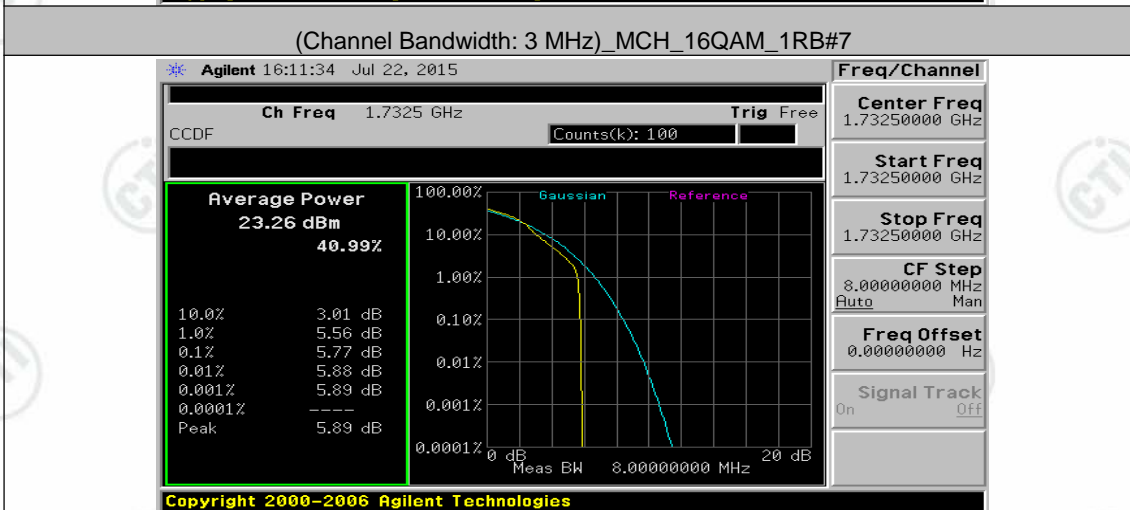
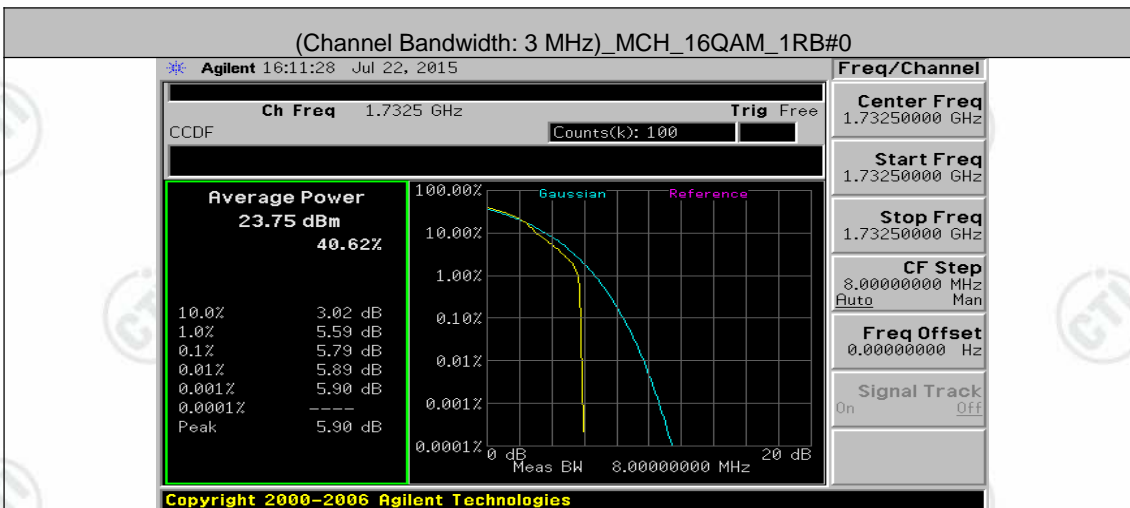
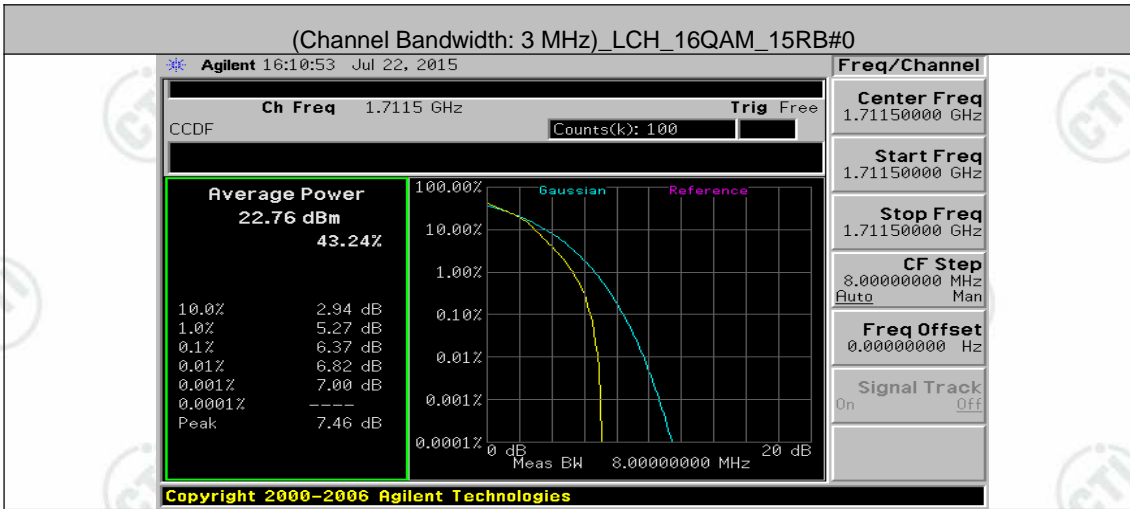



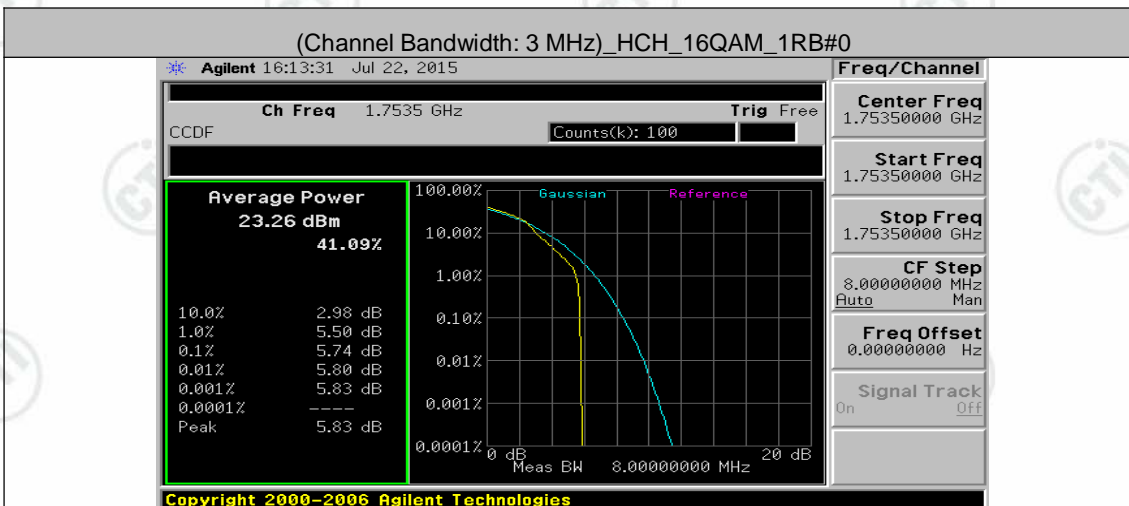
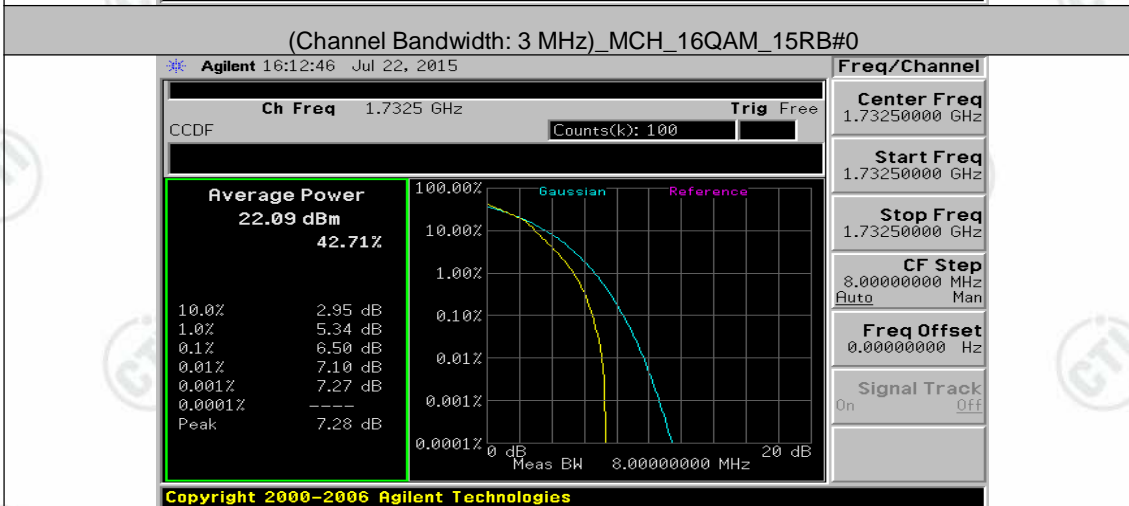
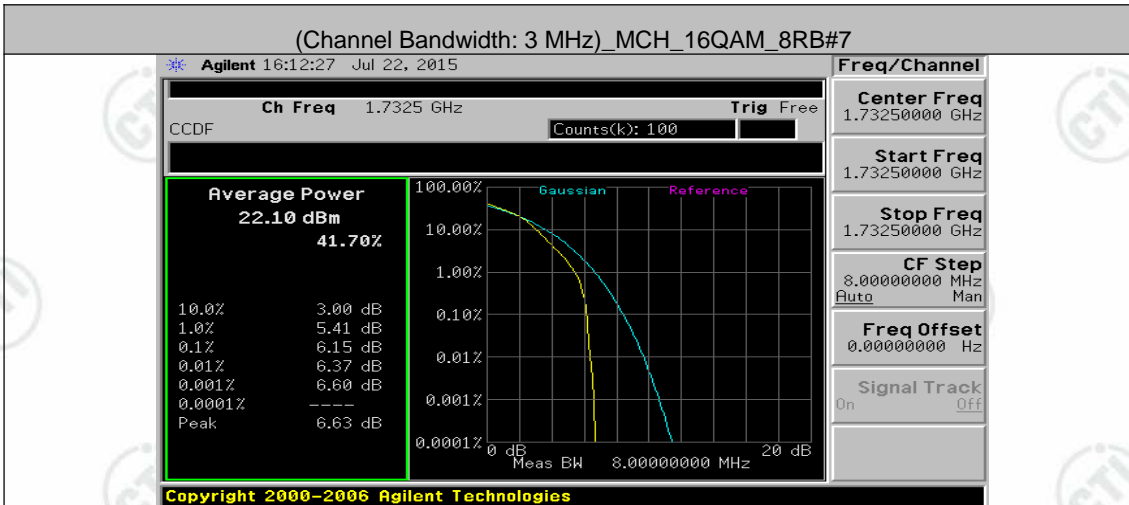

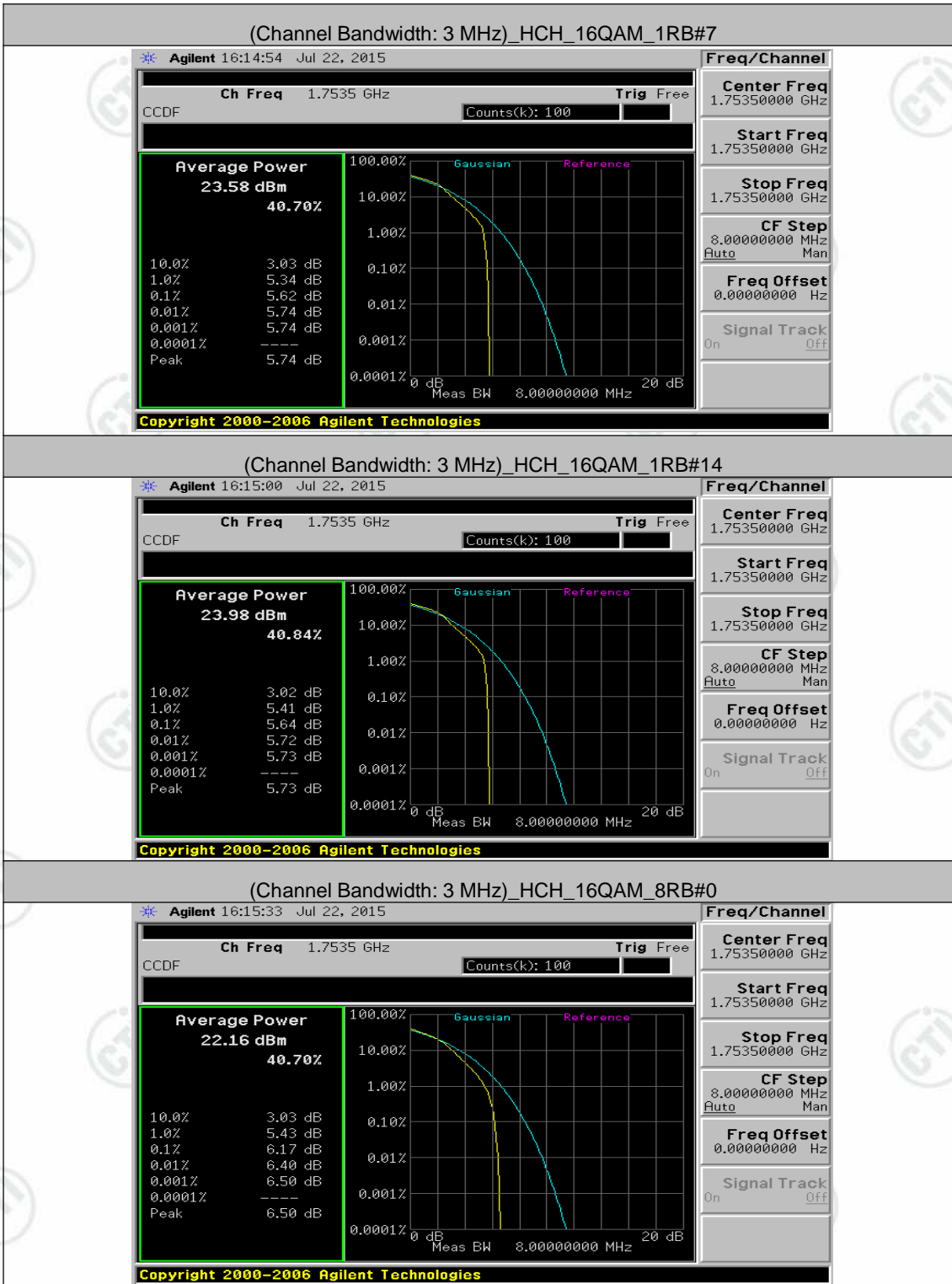

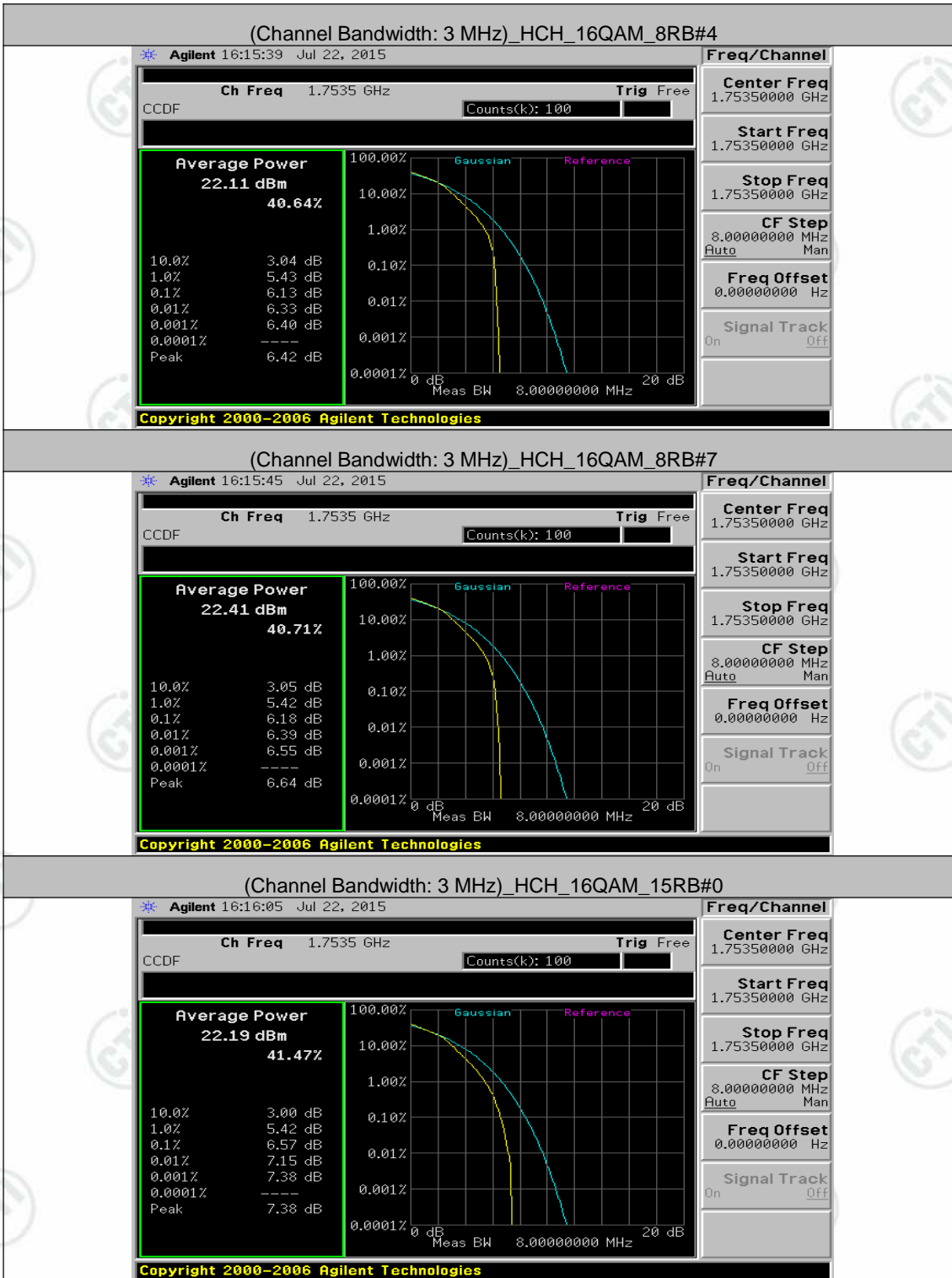

Channel Bandwidth: 5 MHz





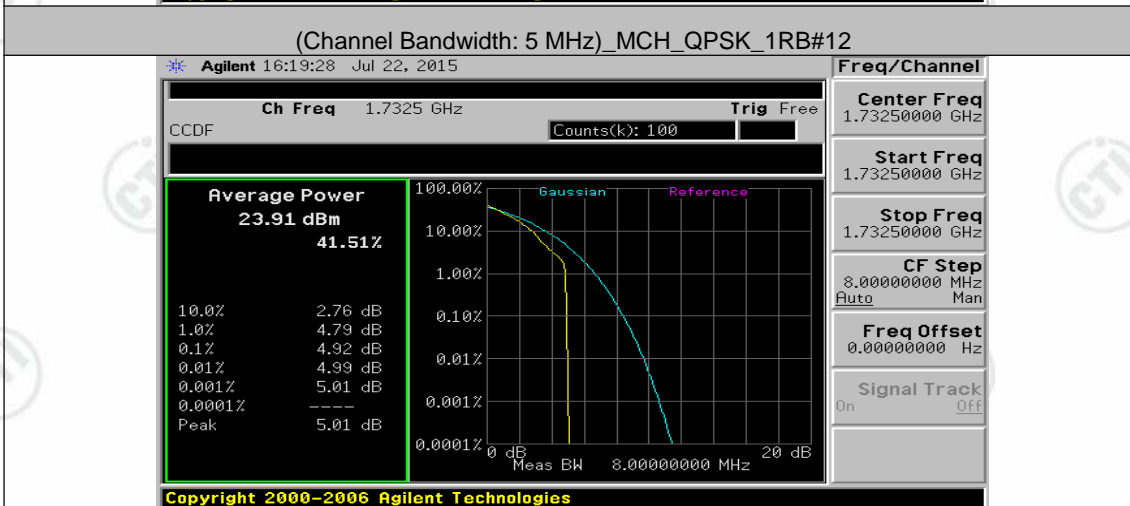
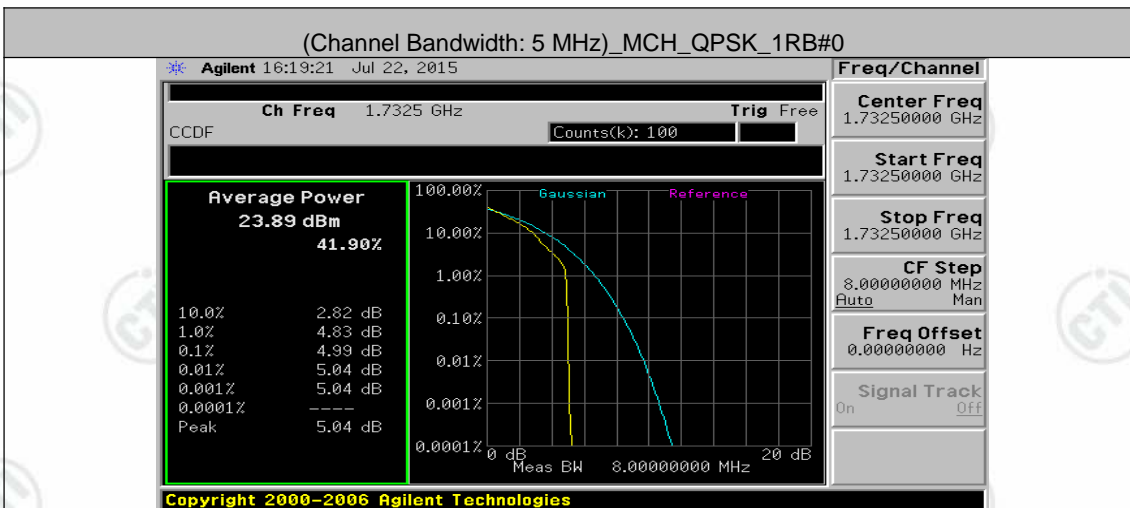
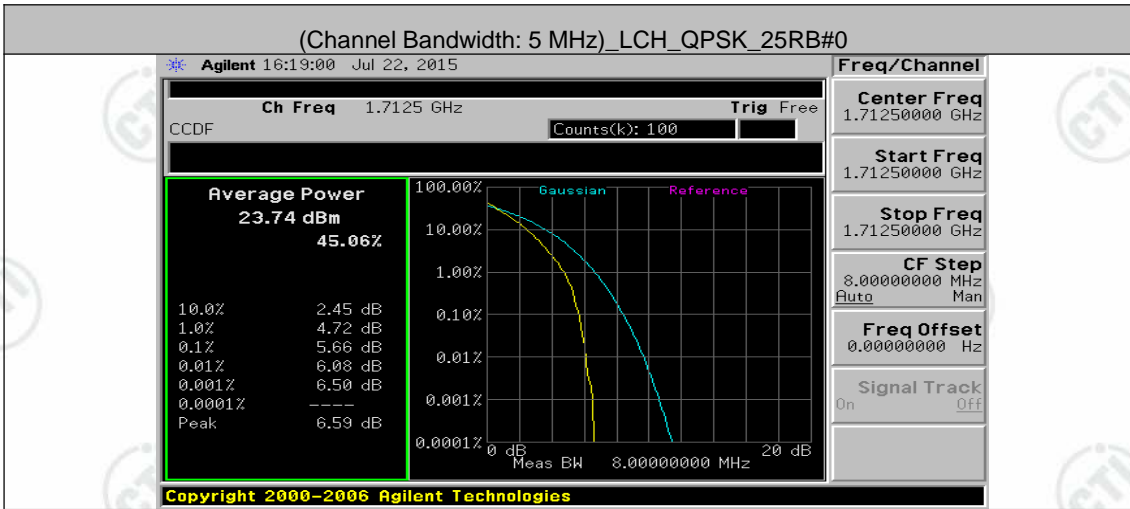



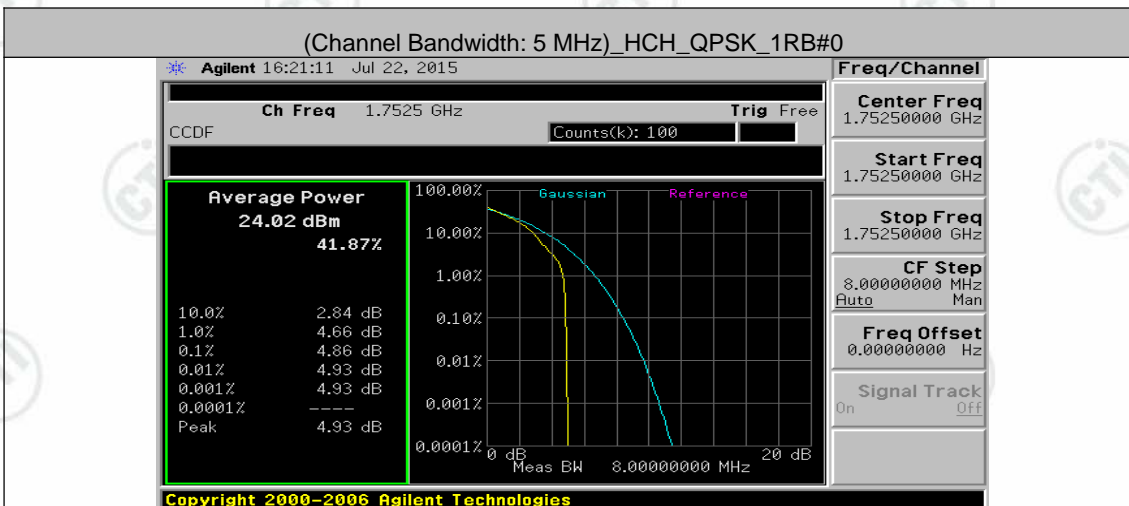
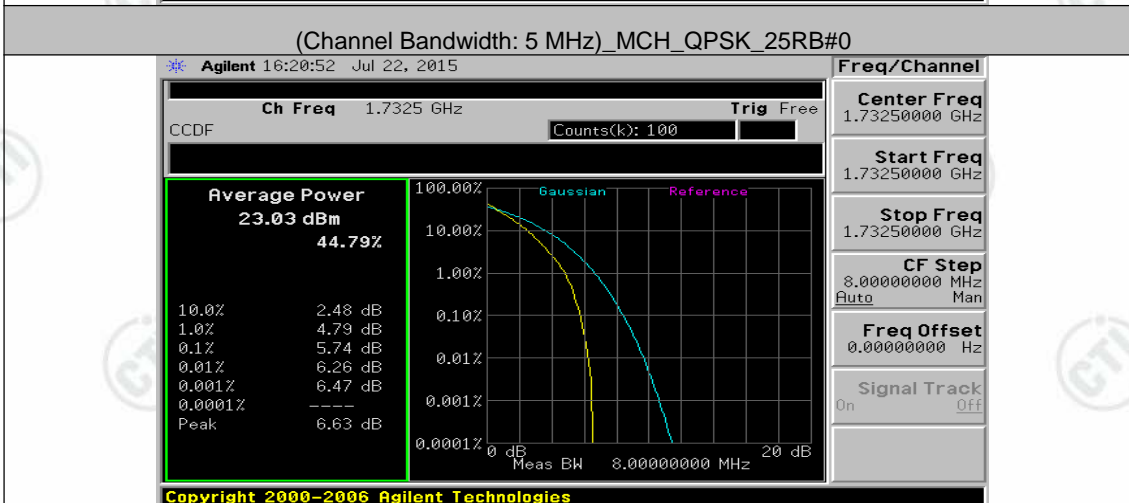
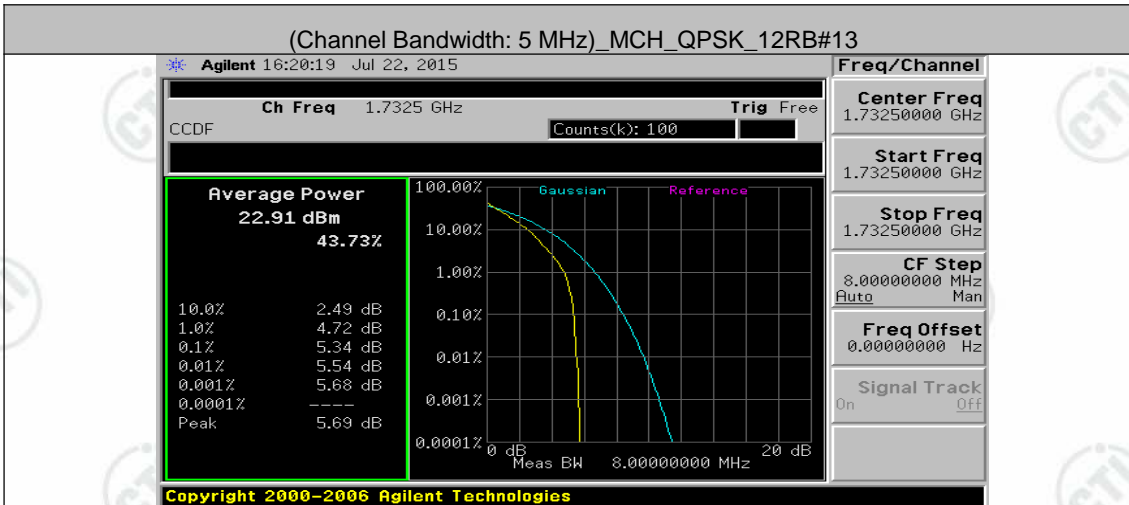







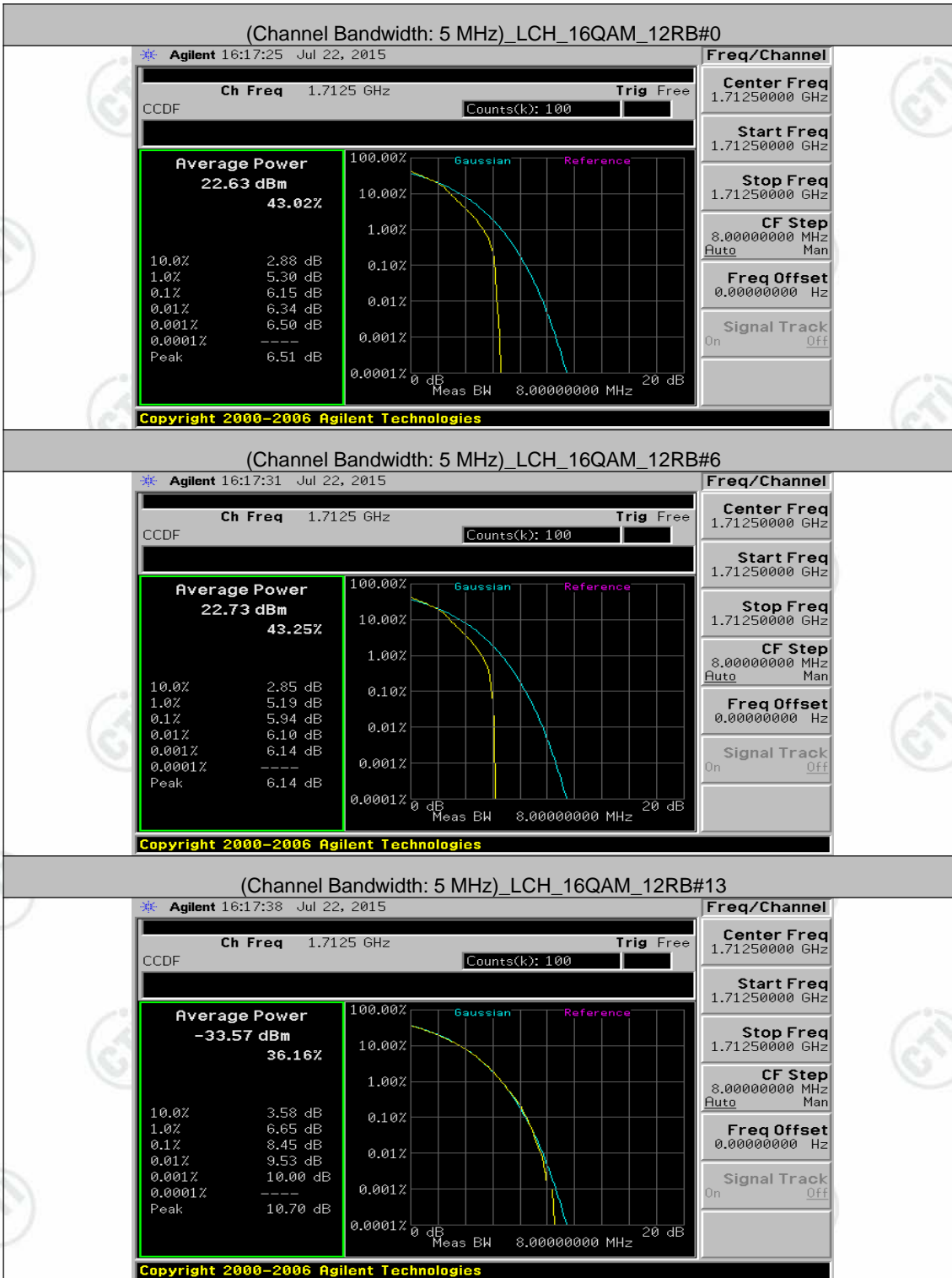

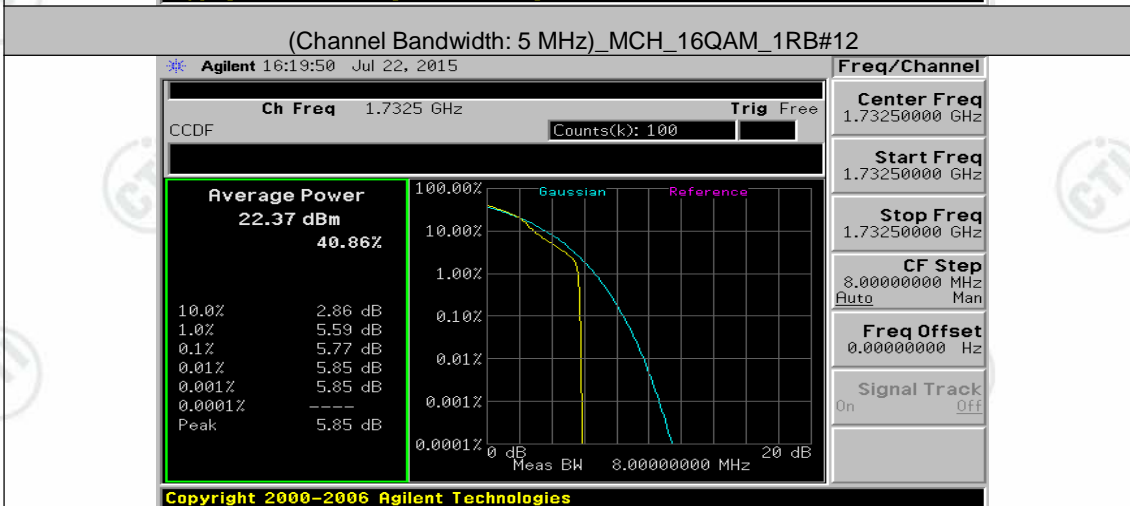
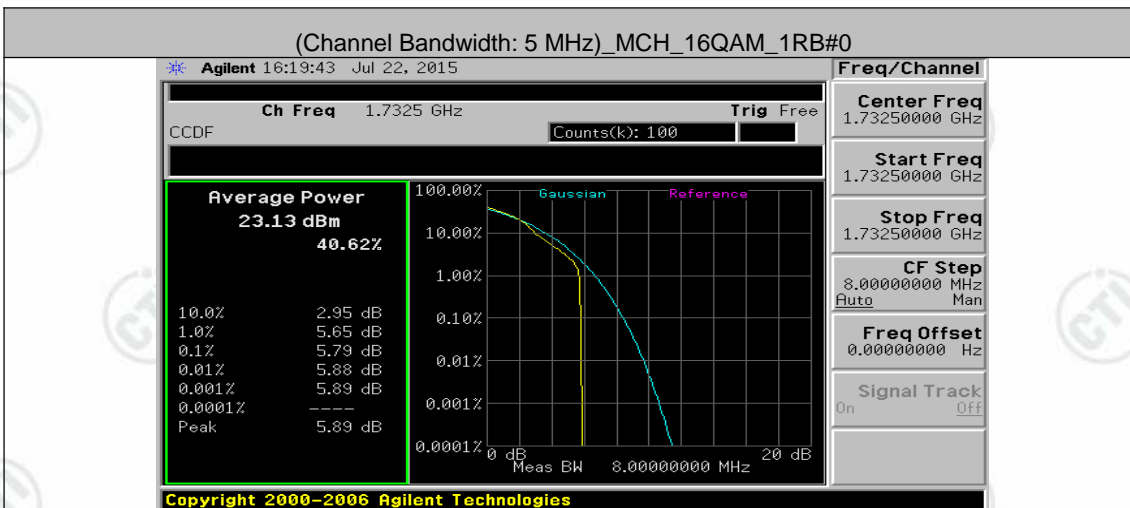
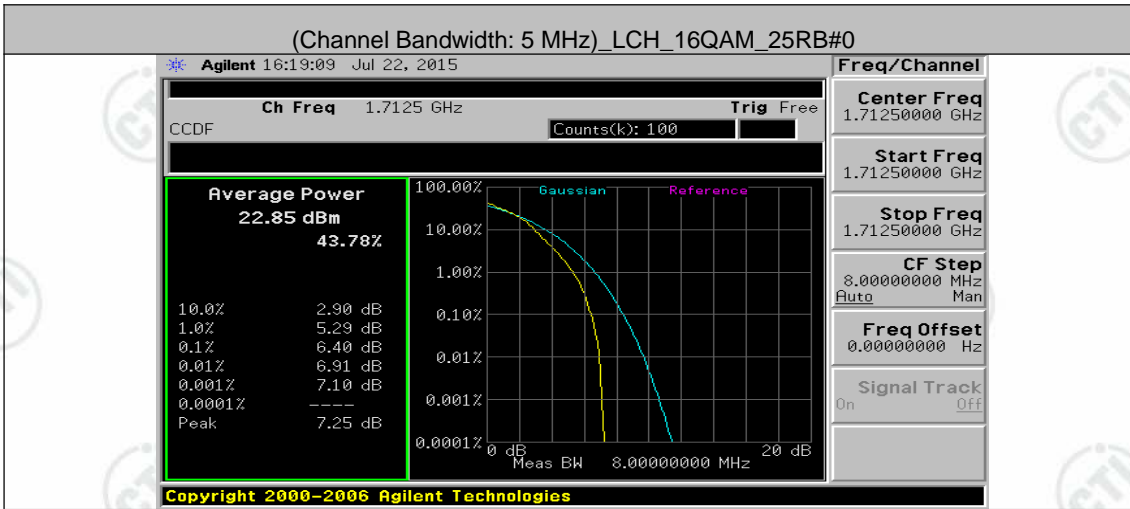



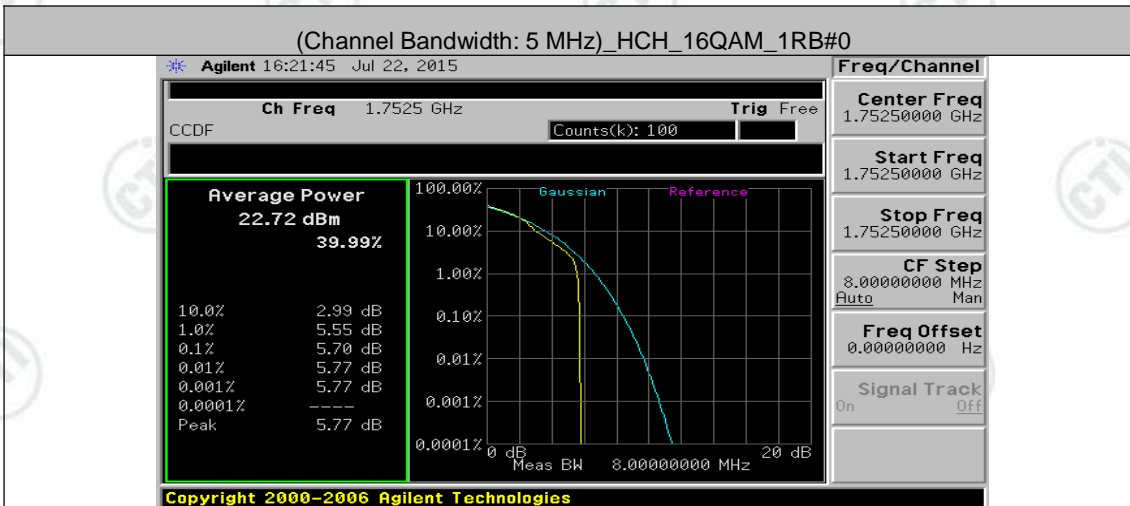
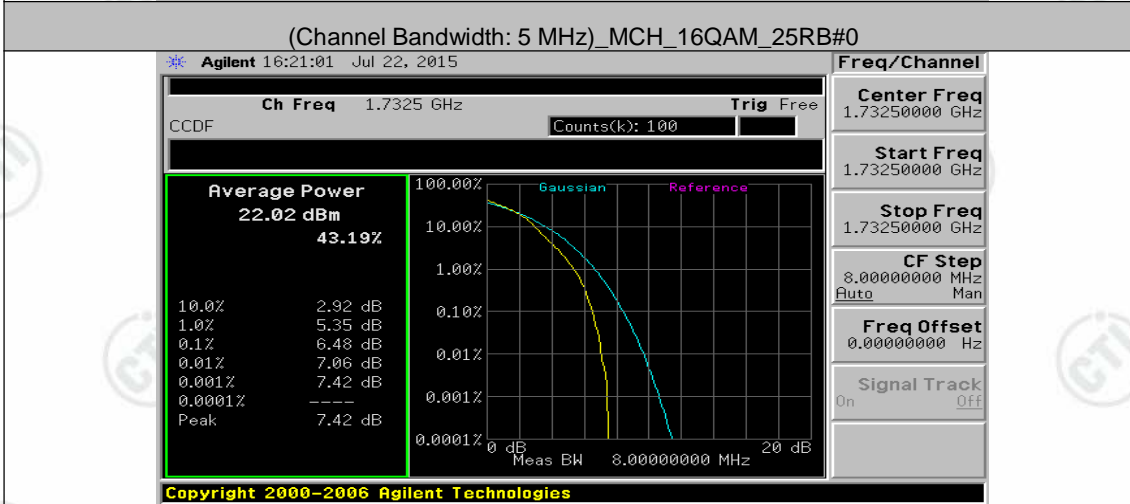
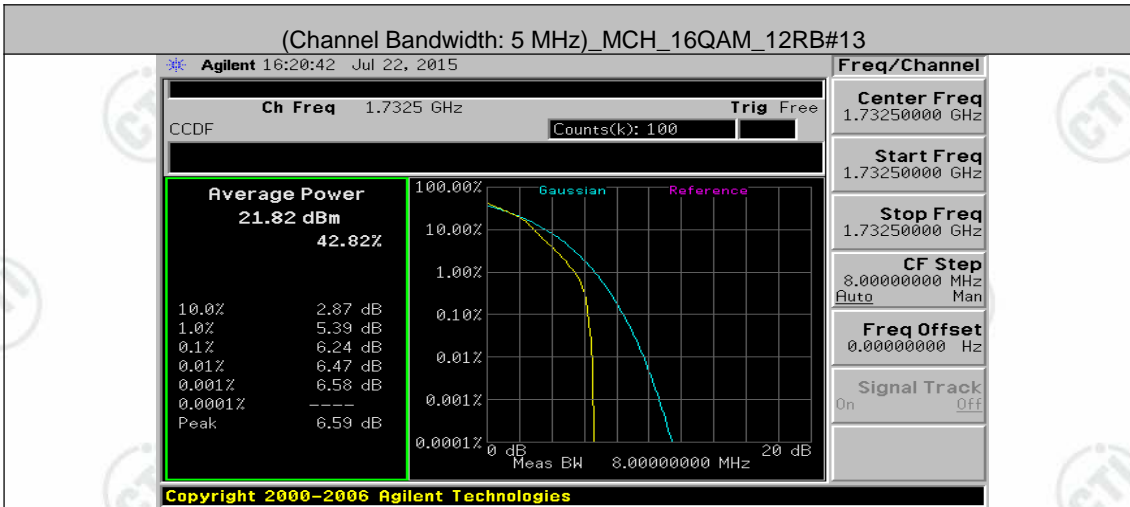





Channel Bandwidth: 10 MHz





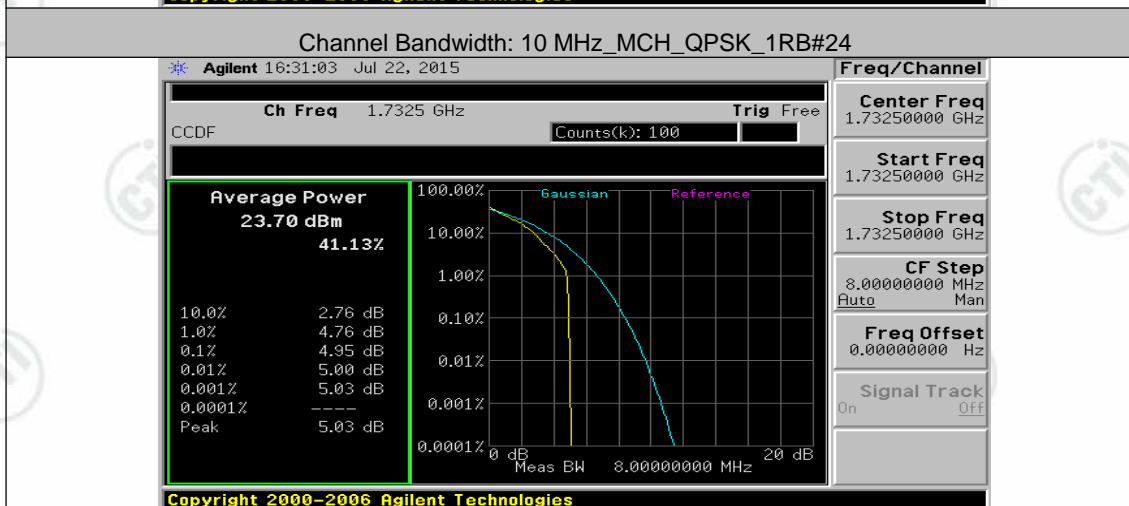
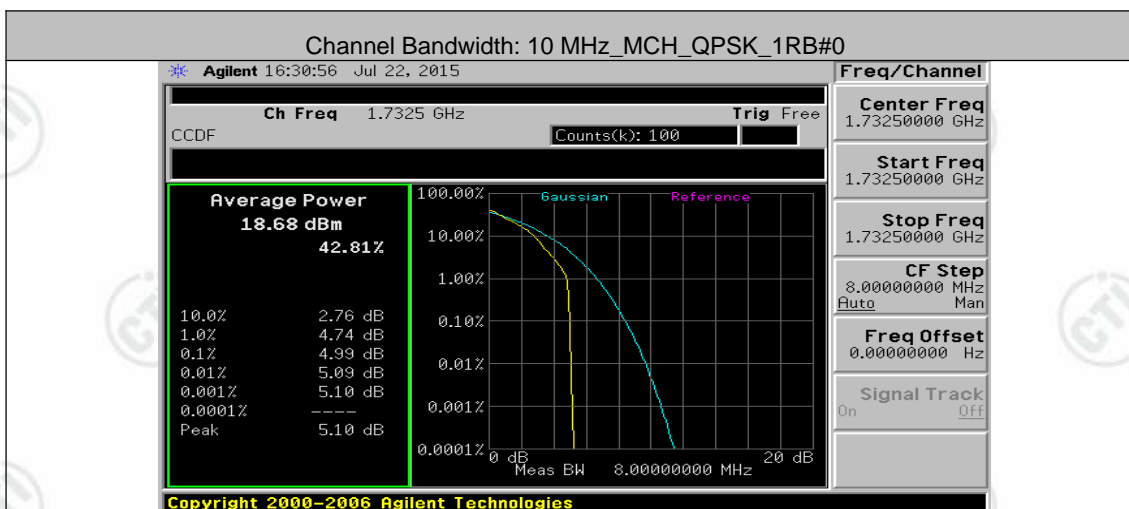
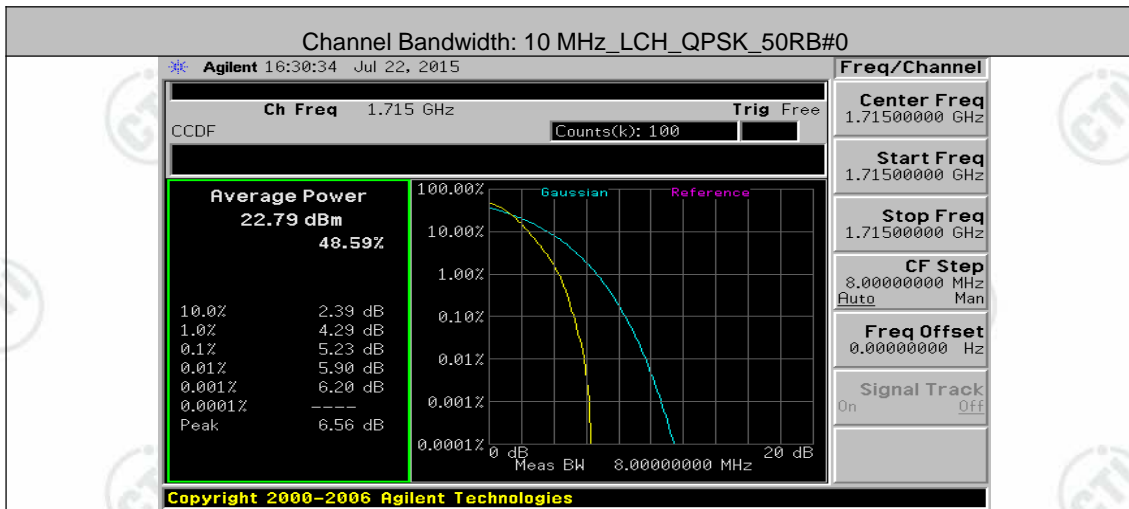



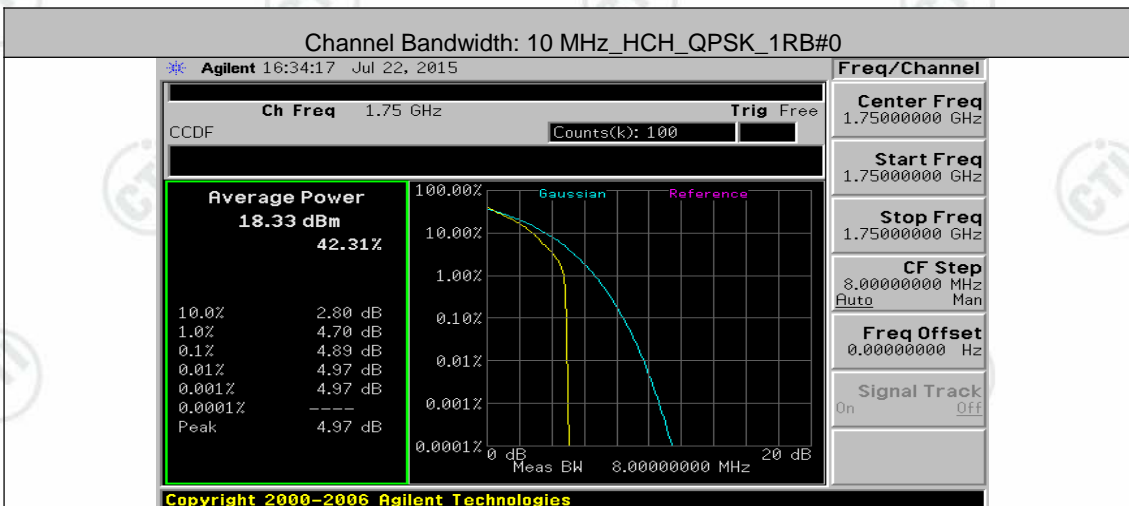
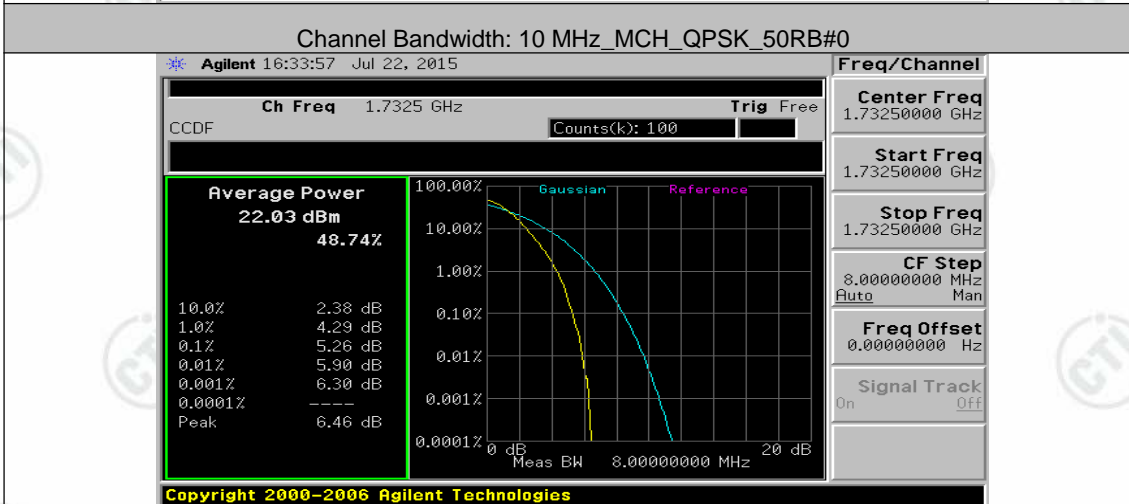
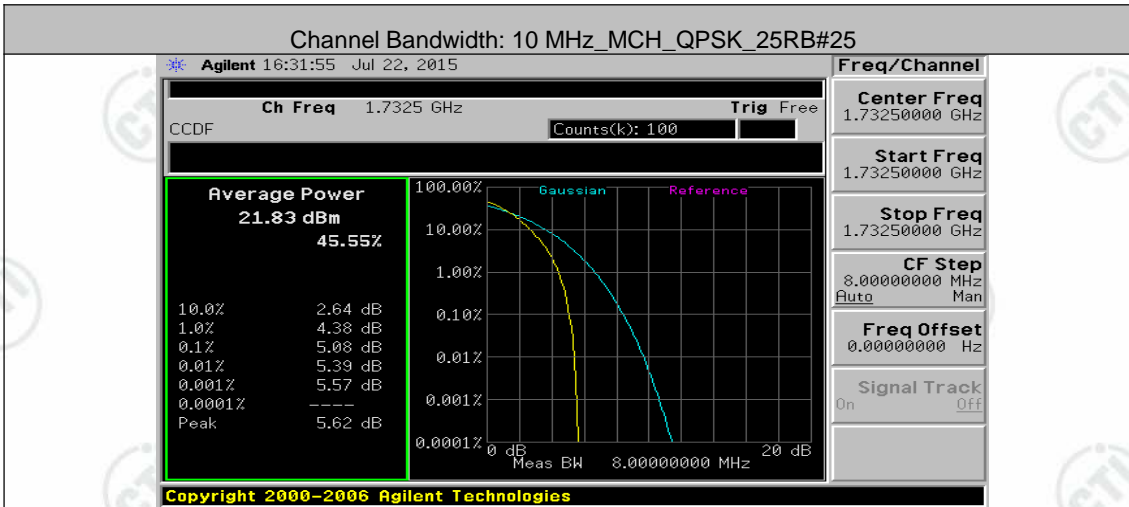





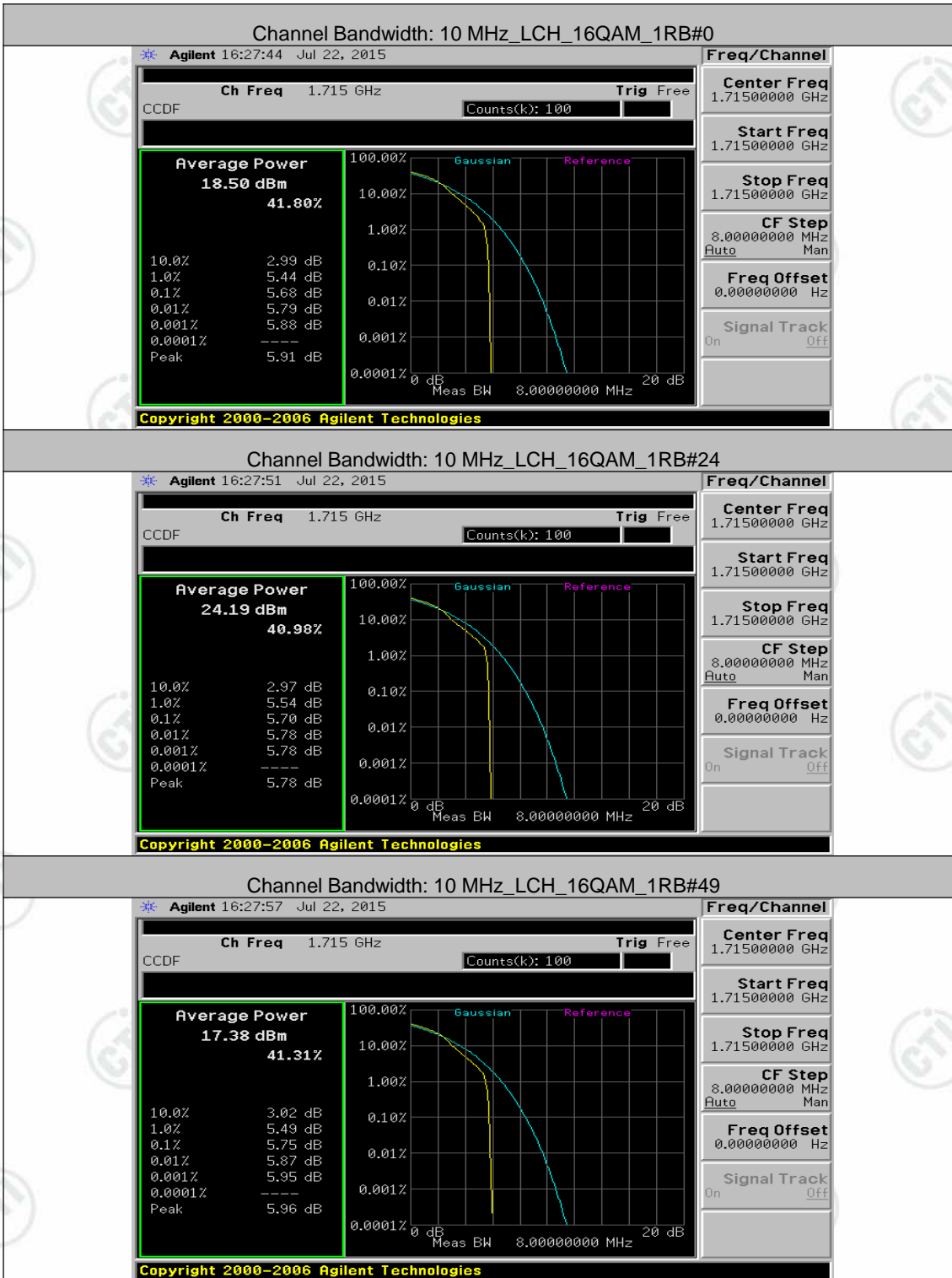



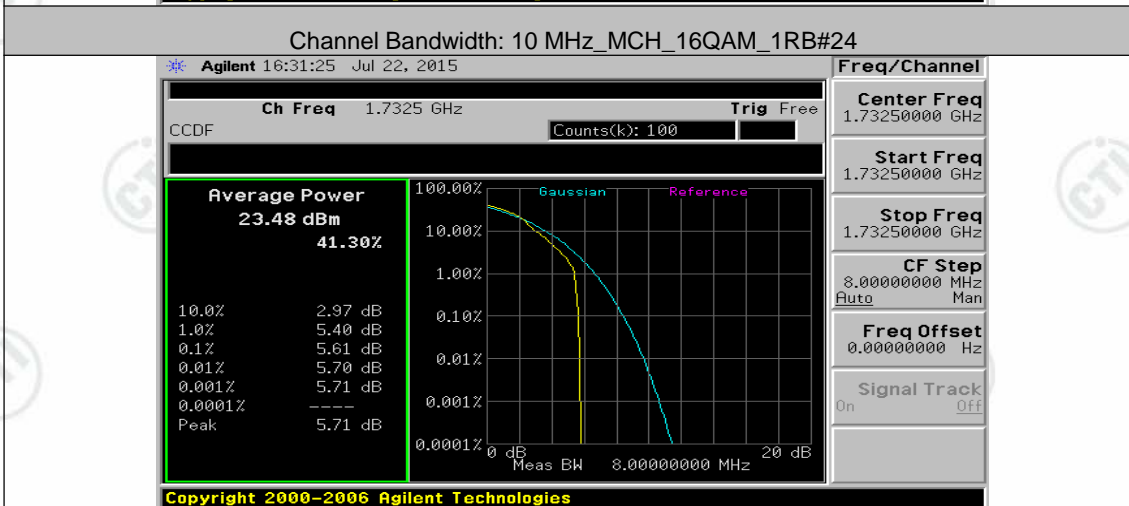
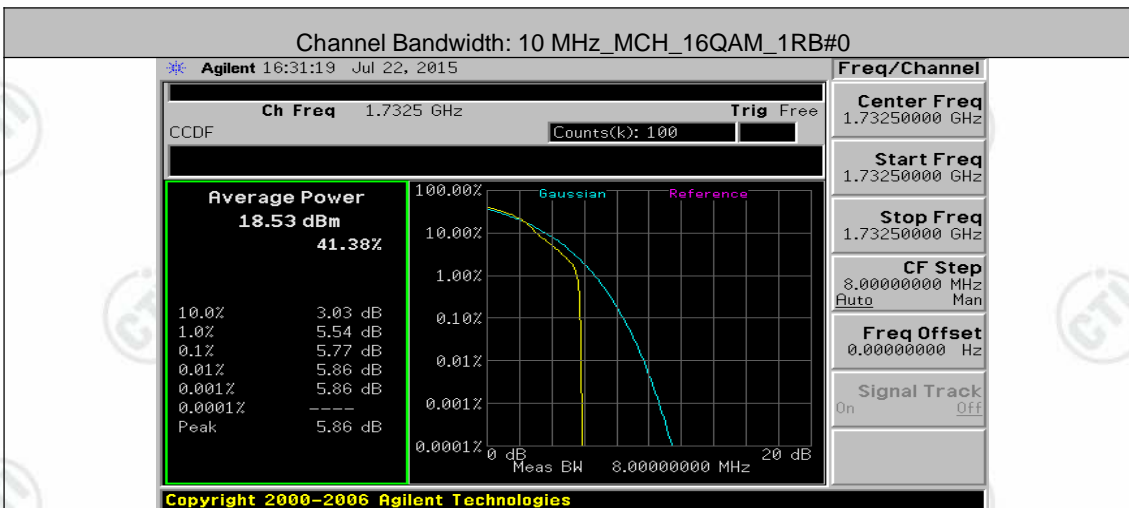
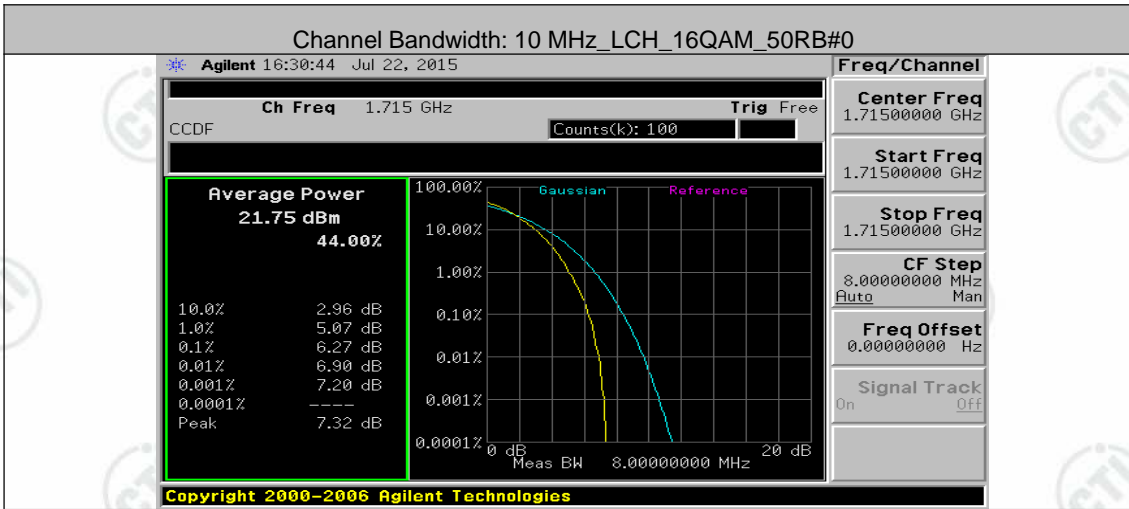

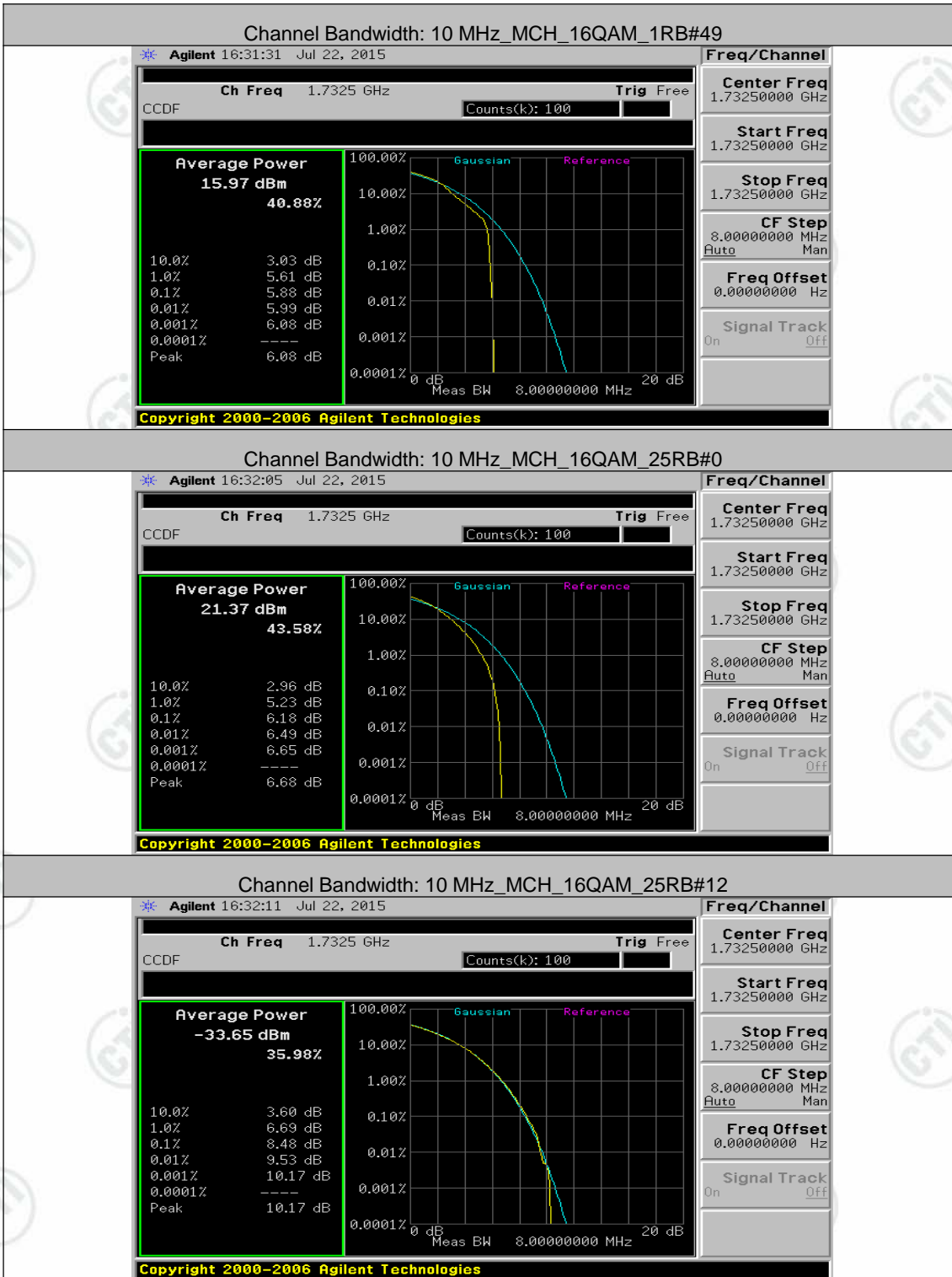

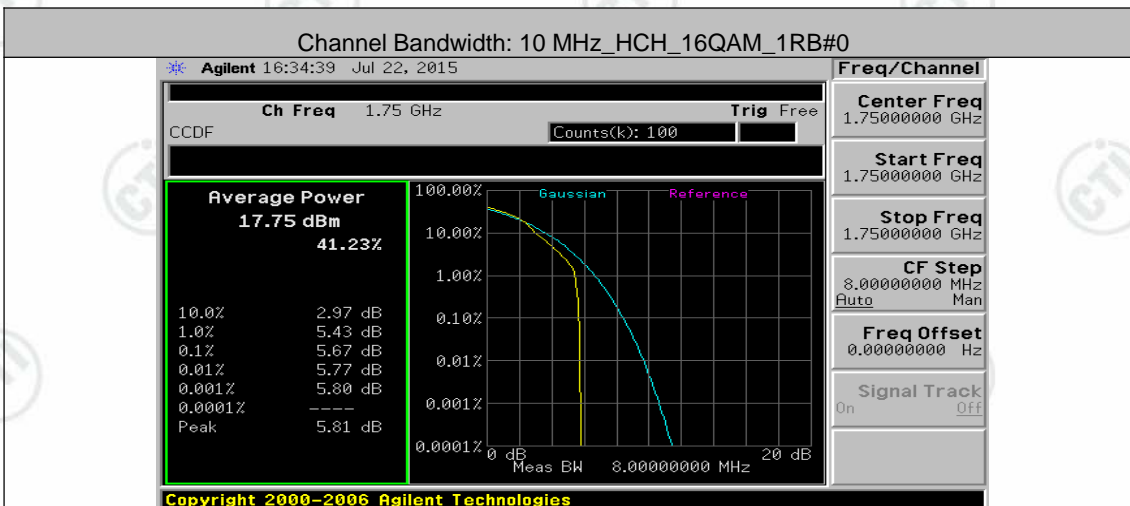
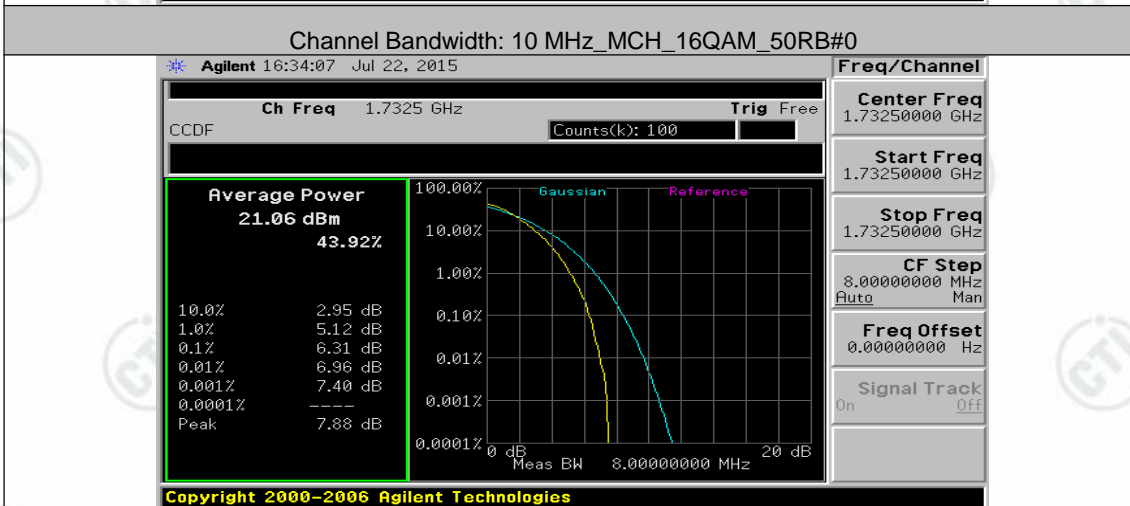
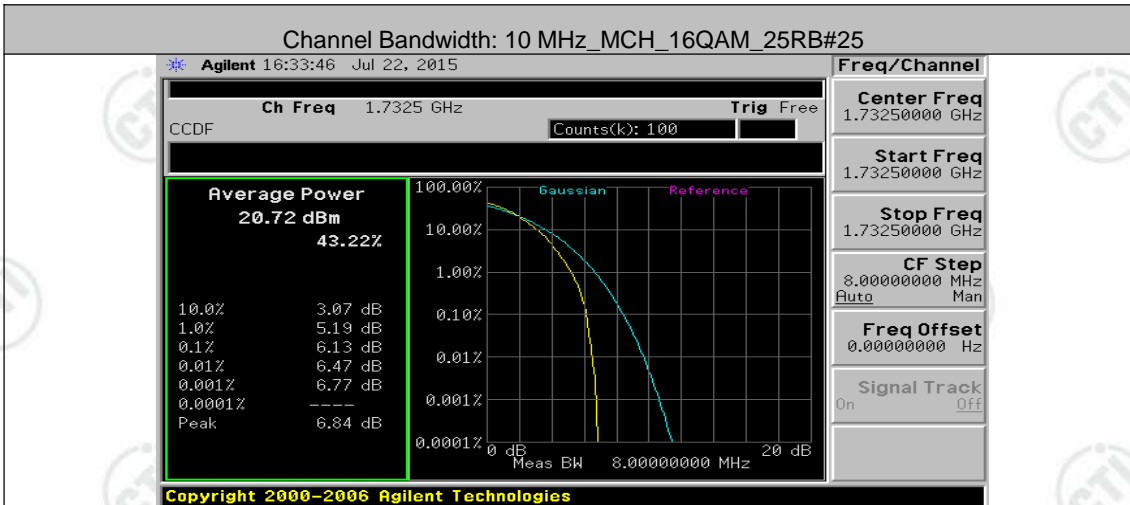

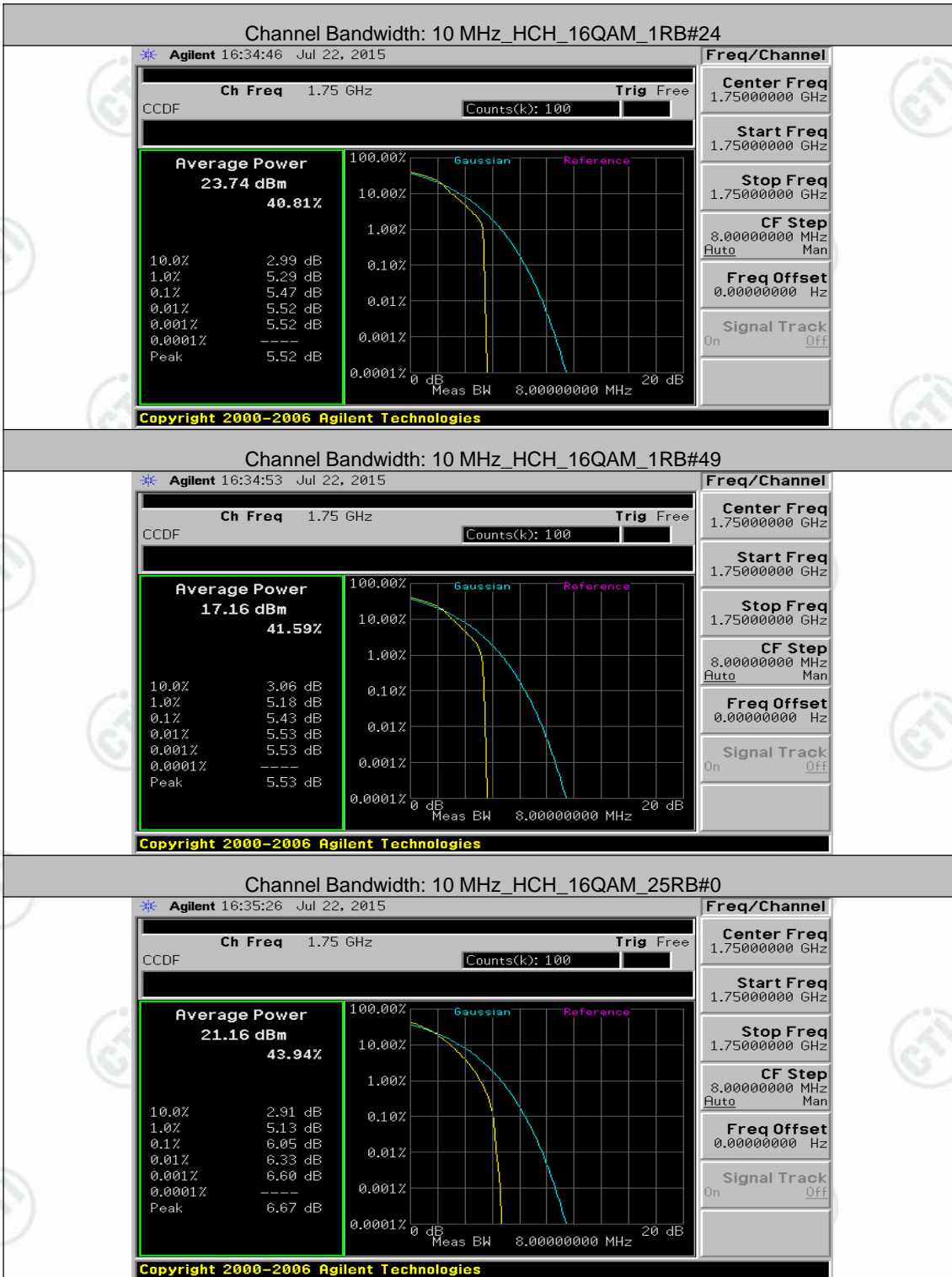



Channel Bandwidth: 15 MHz

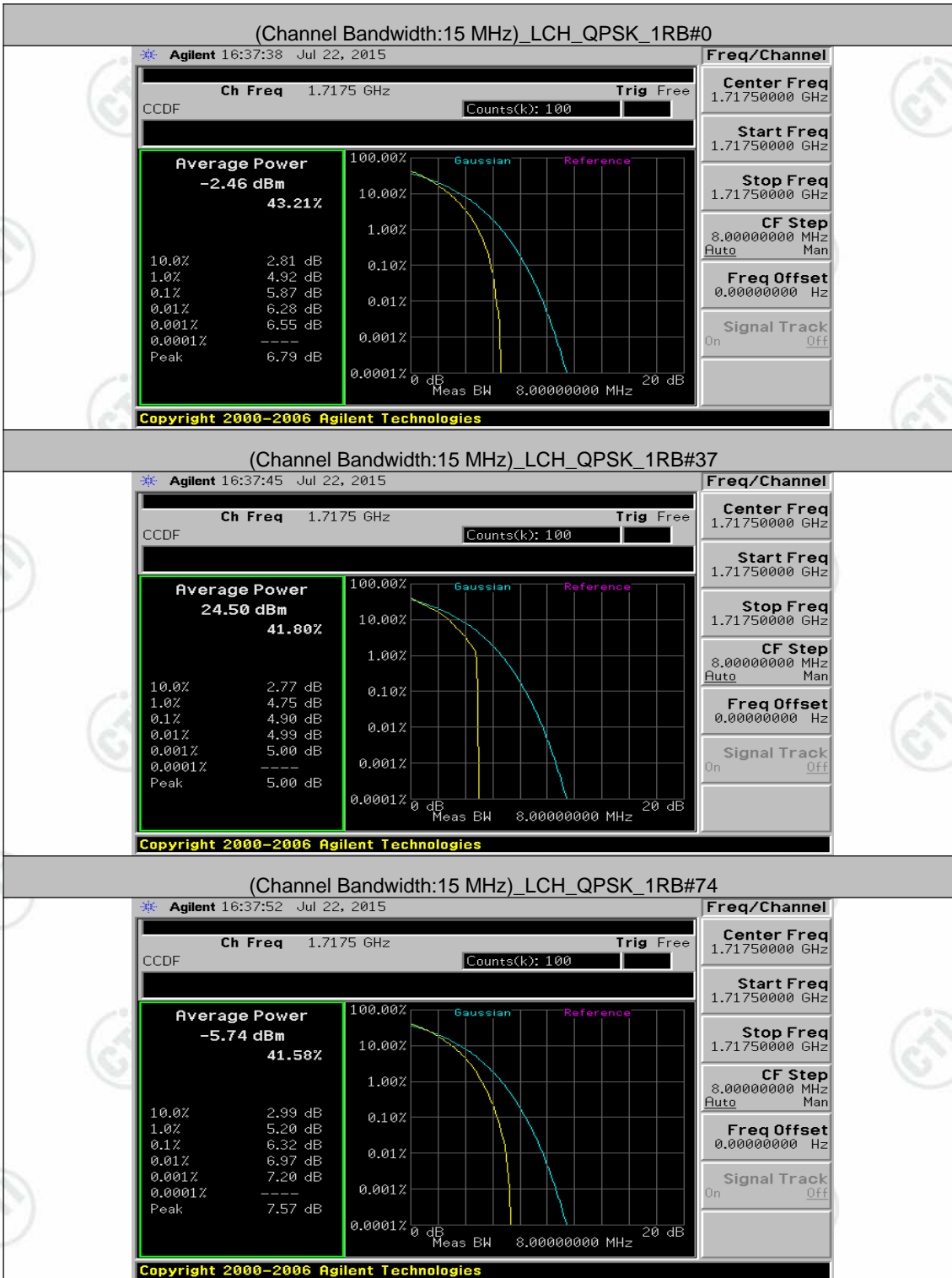



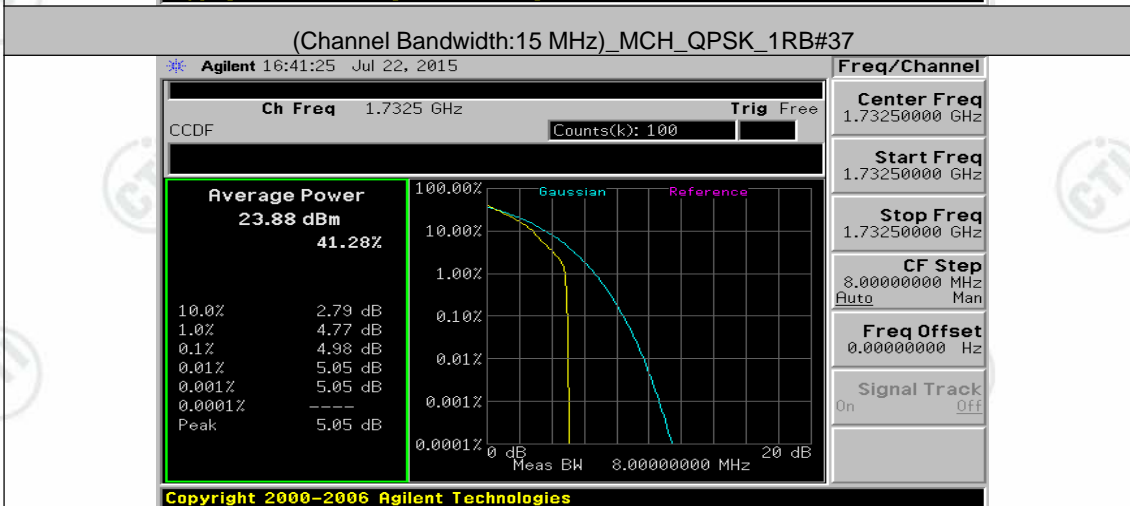
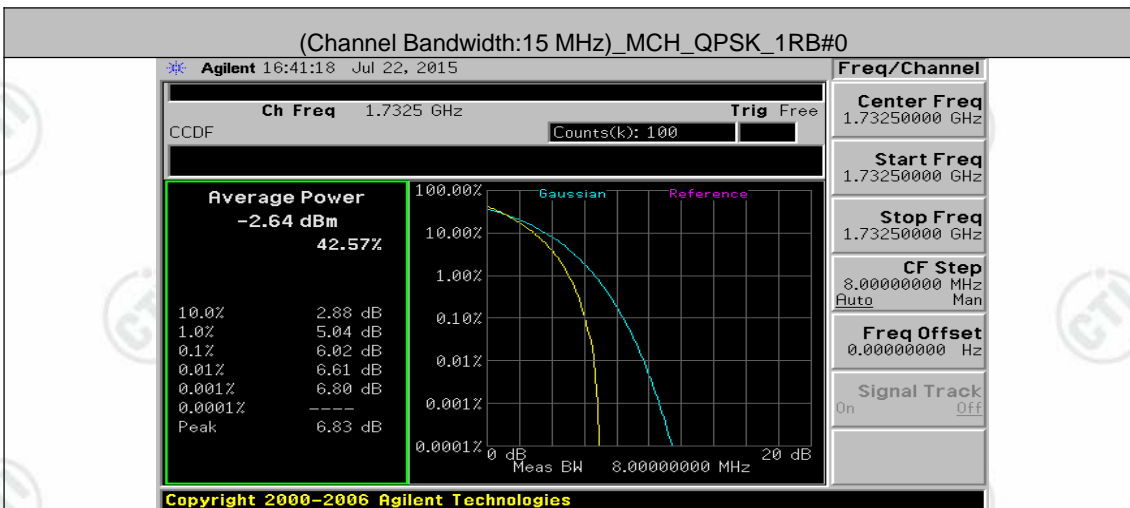
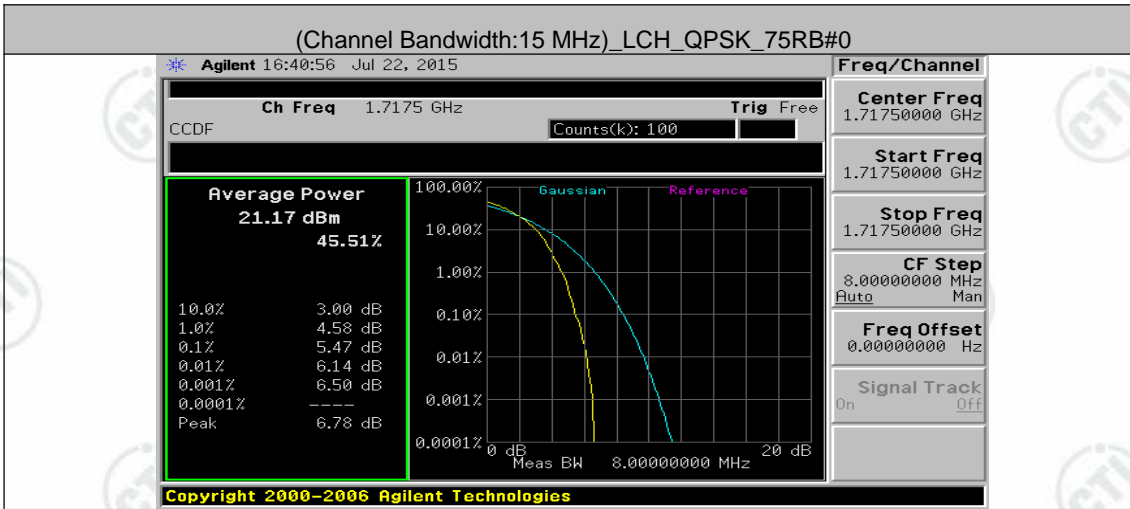

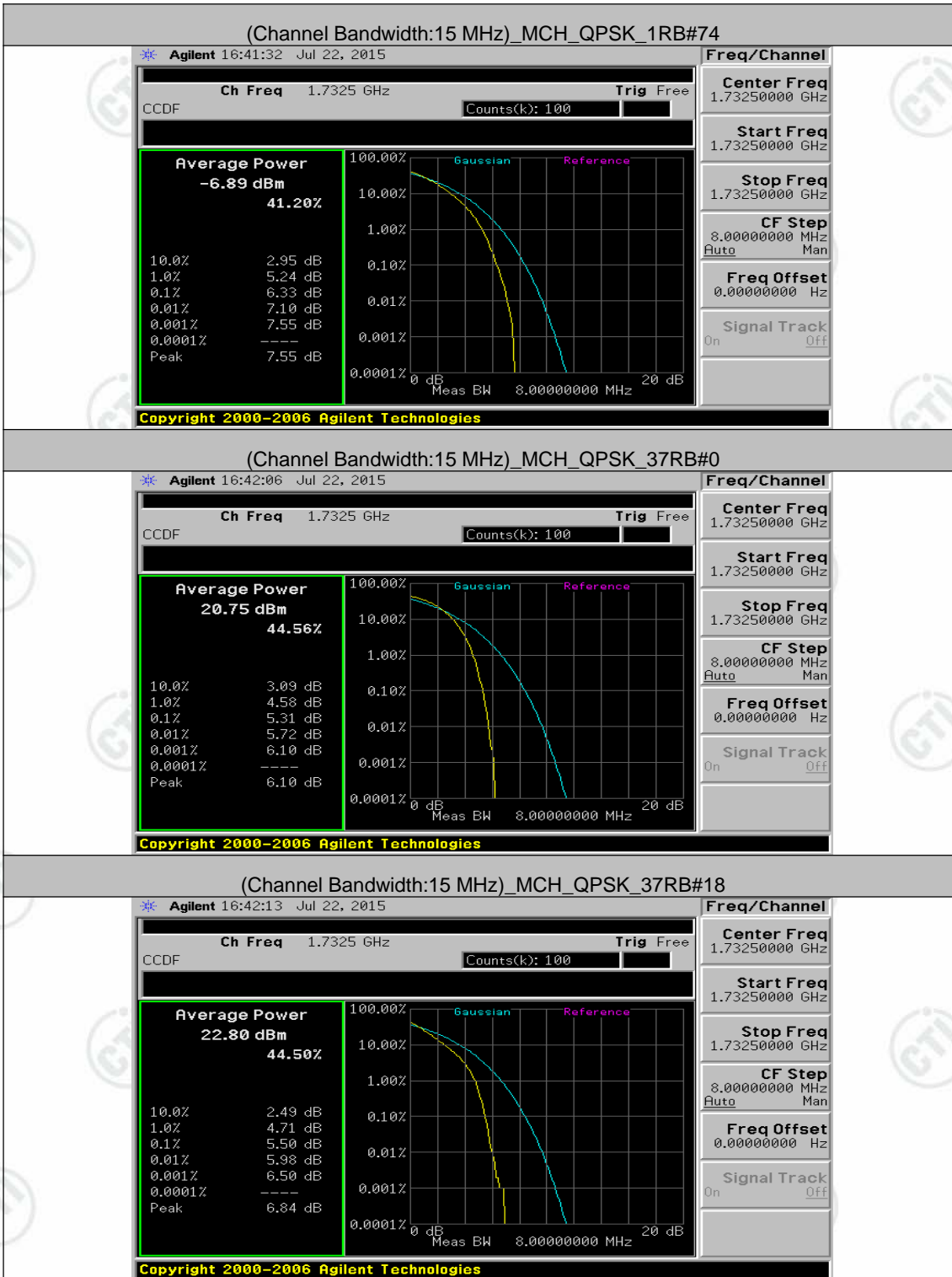

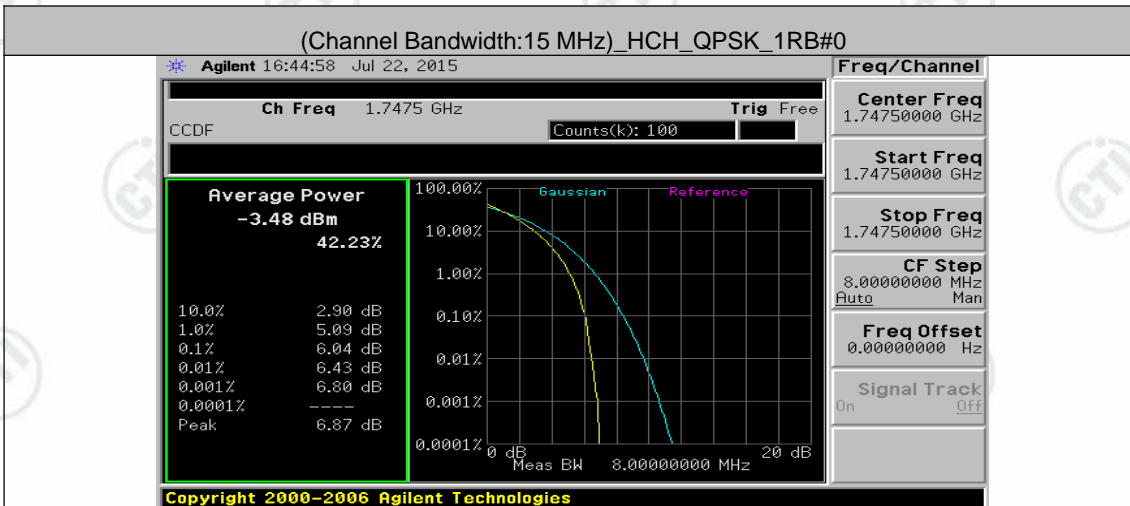
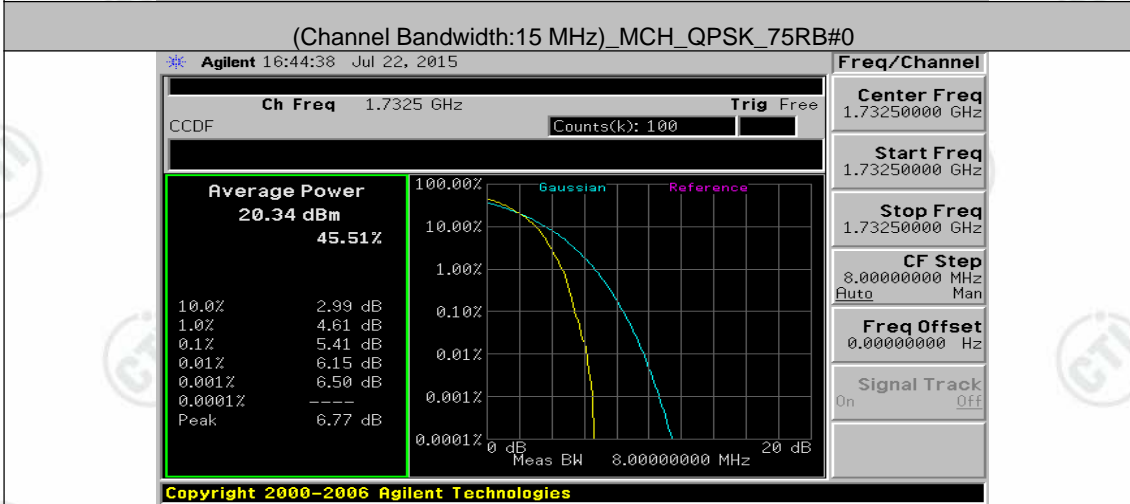
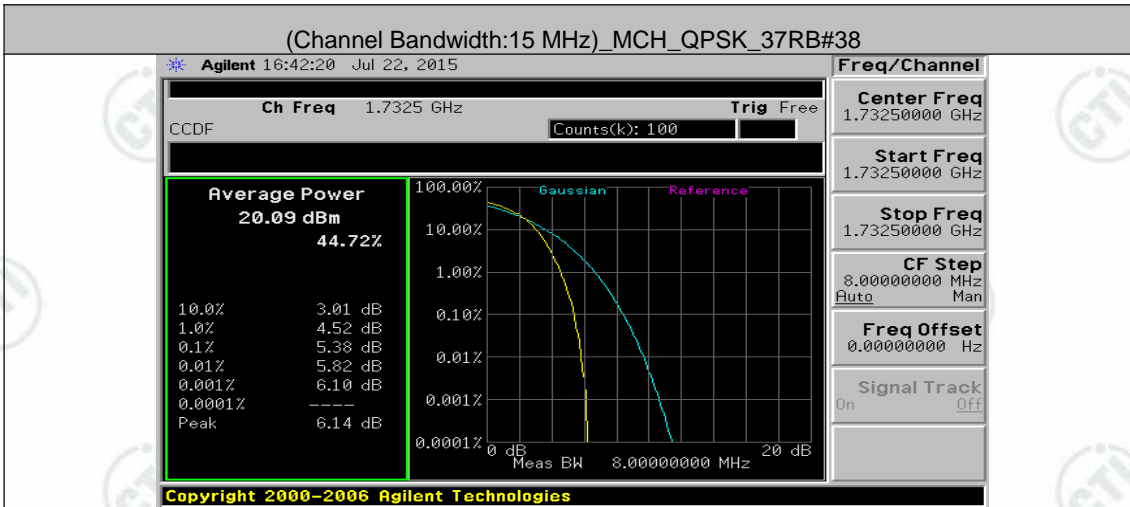

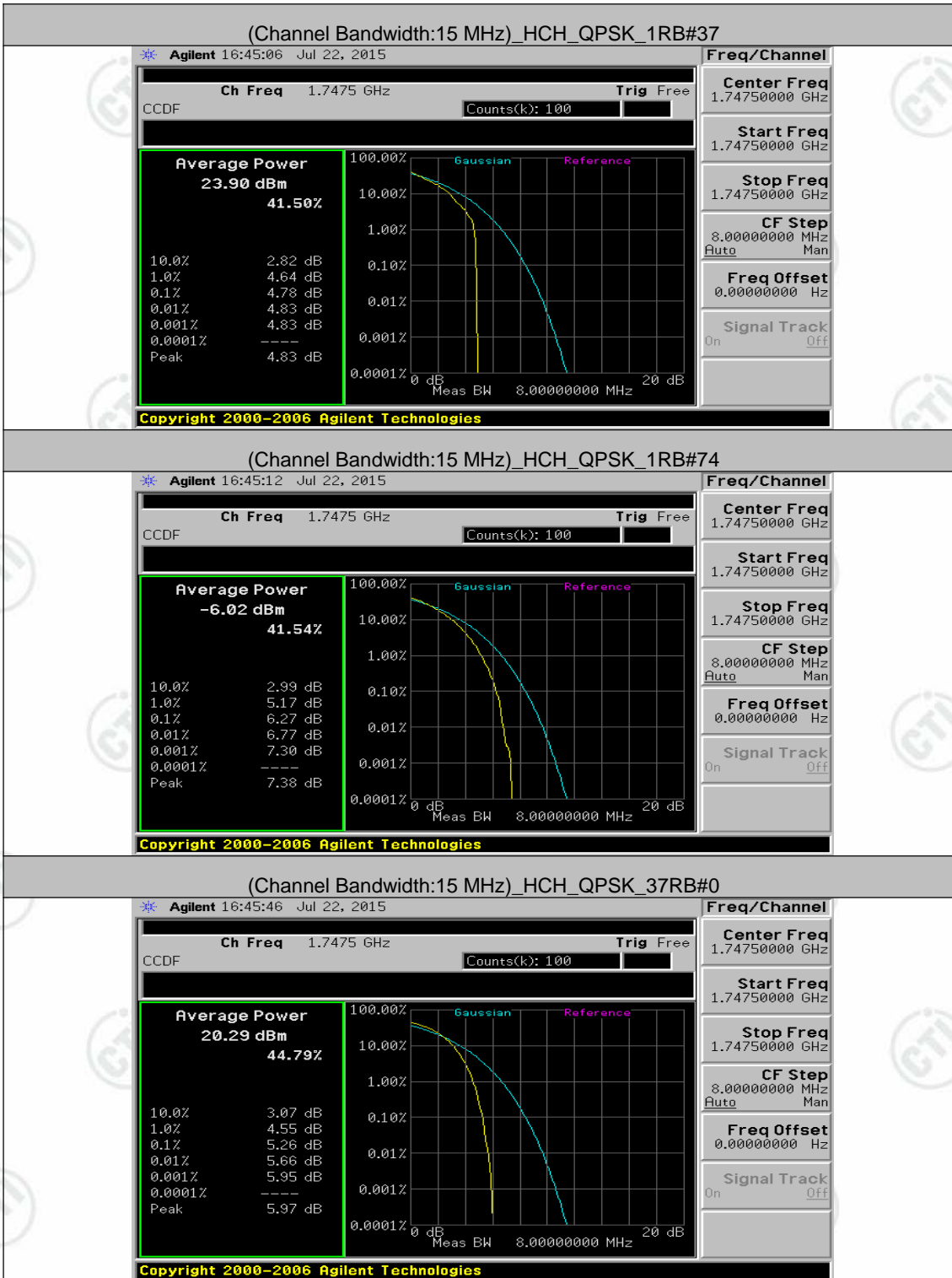







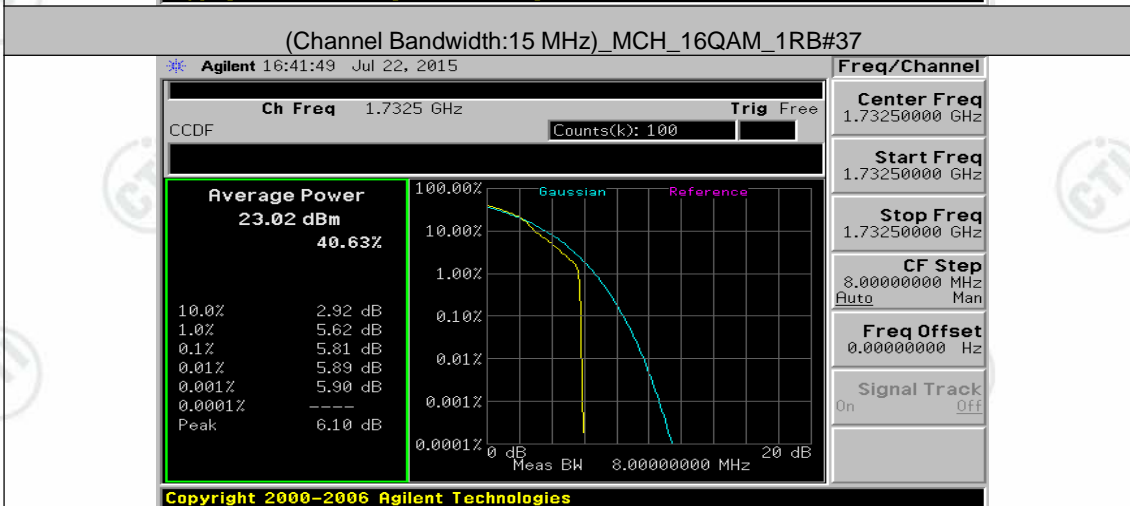
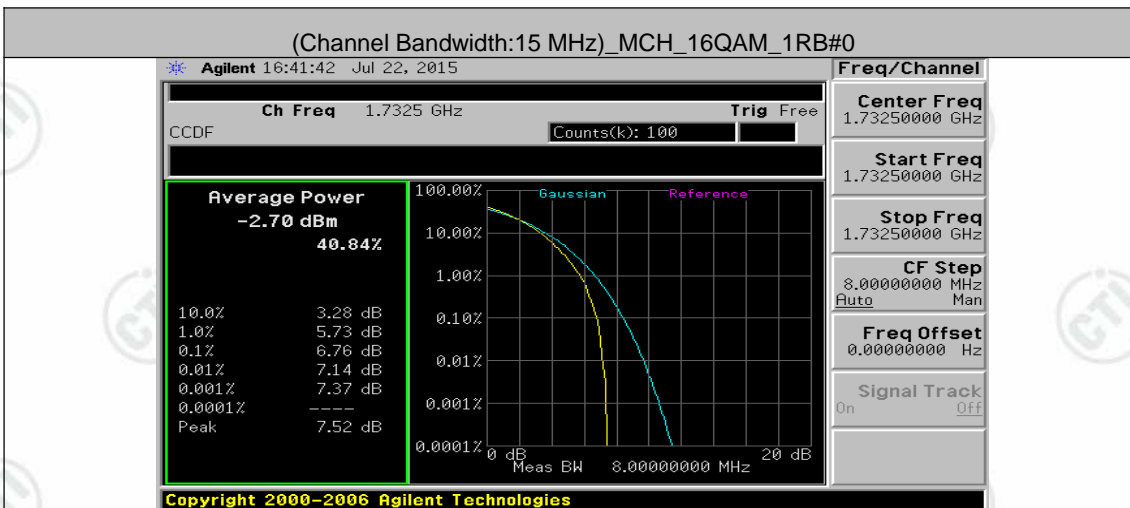
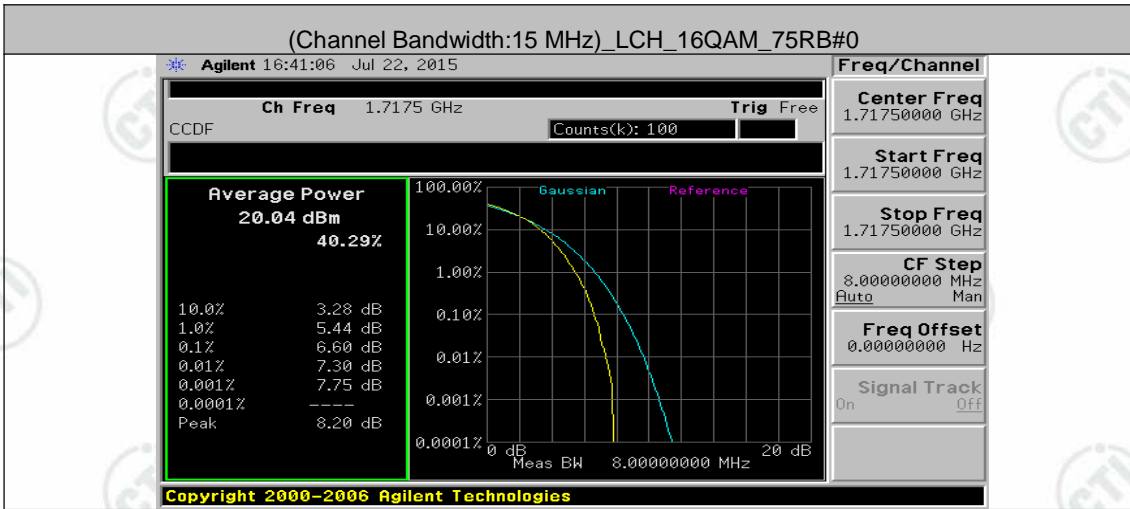

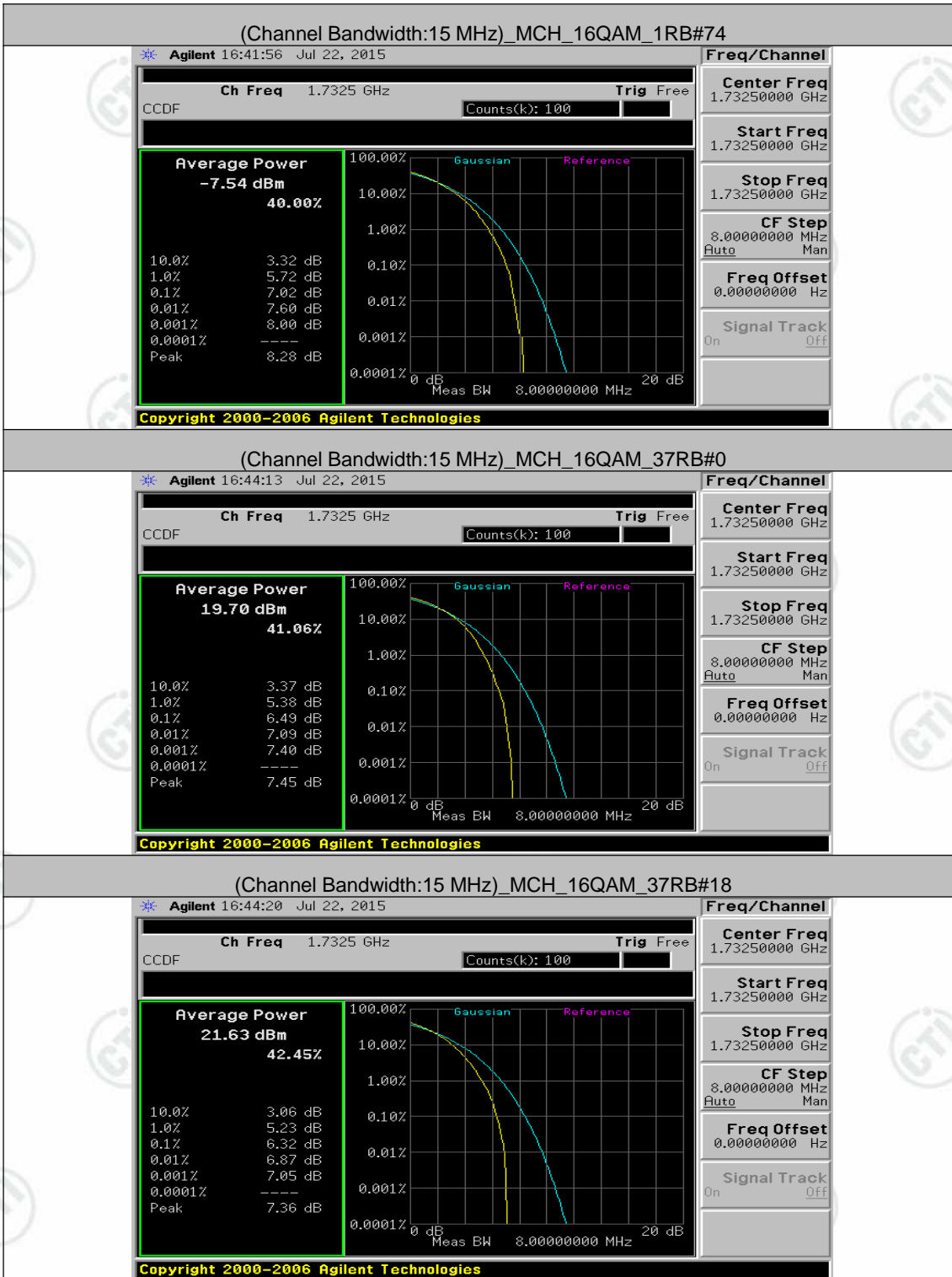

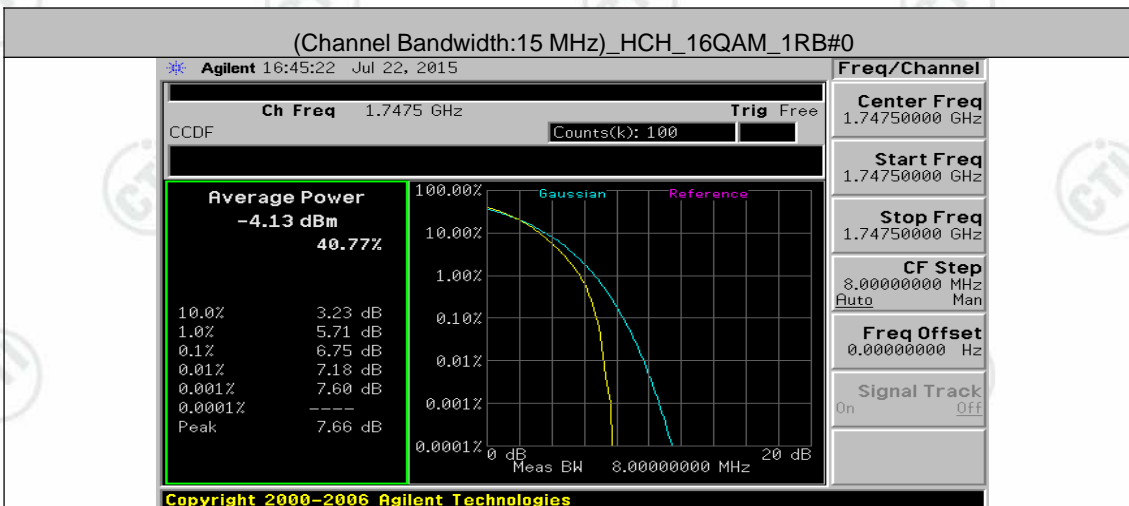
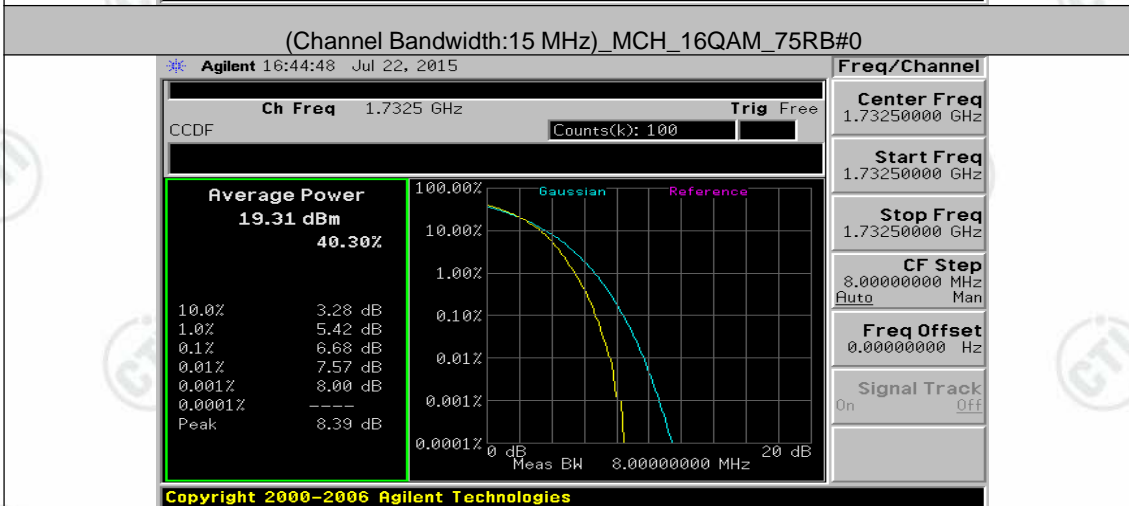
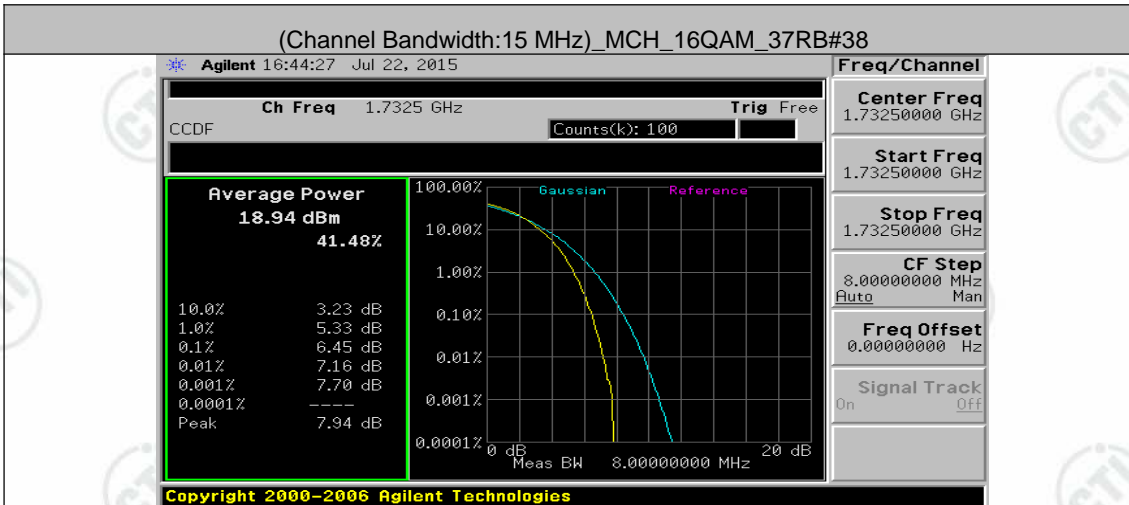

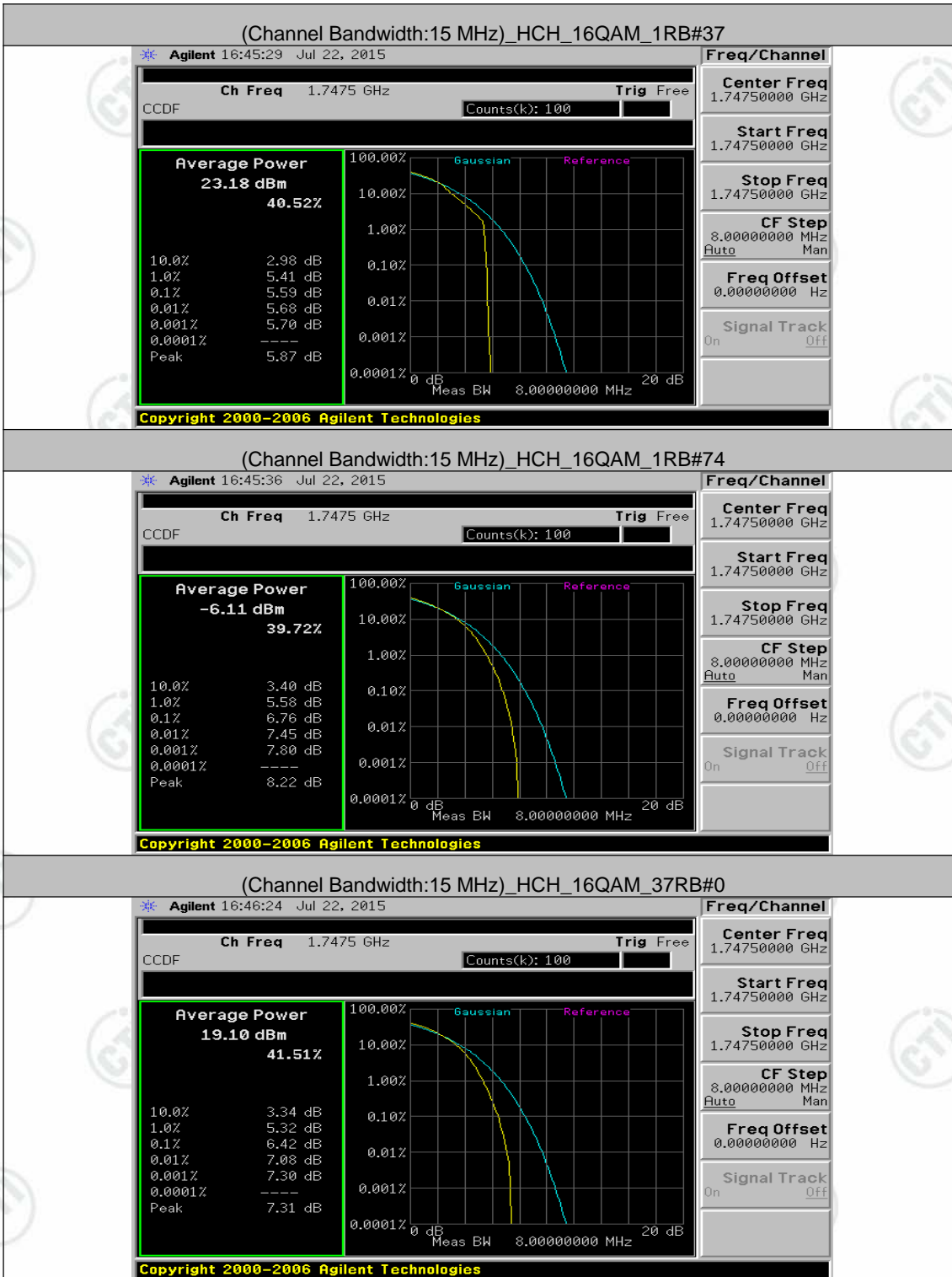

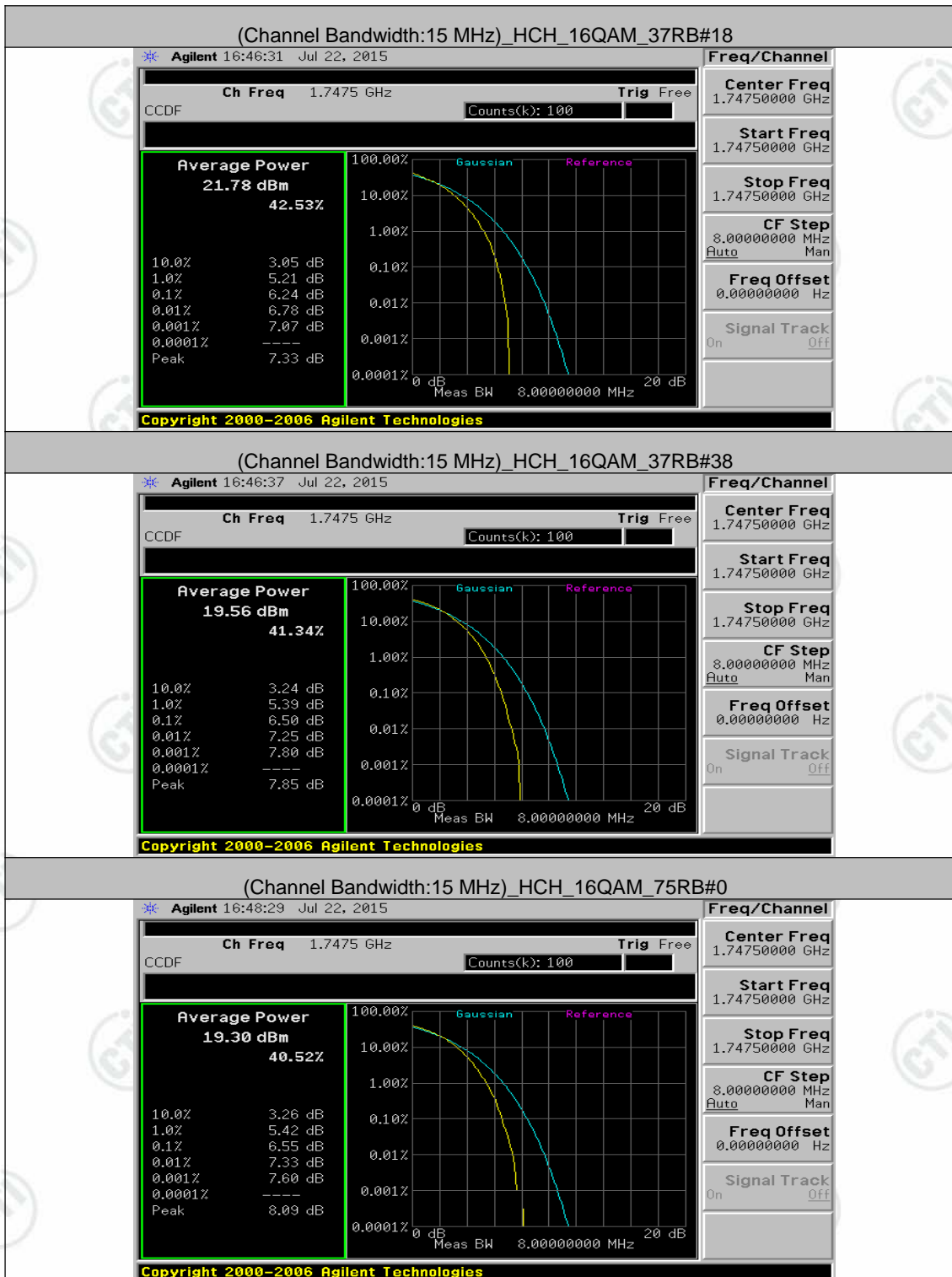

Channel Bandwidth: 20 MHz





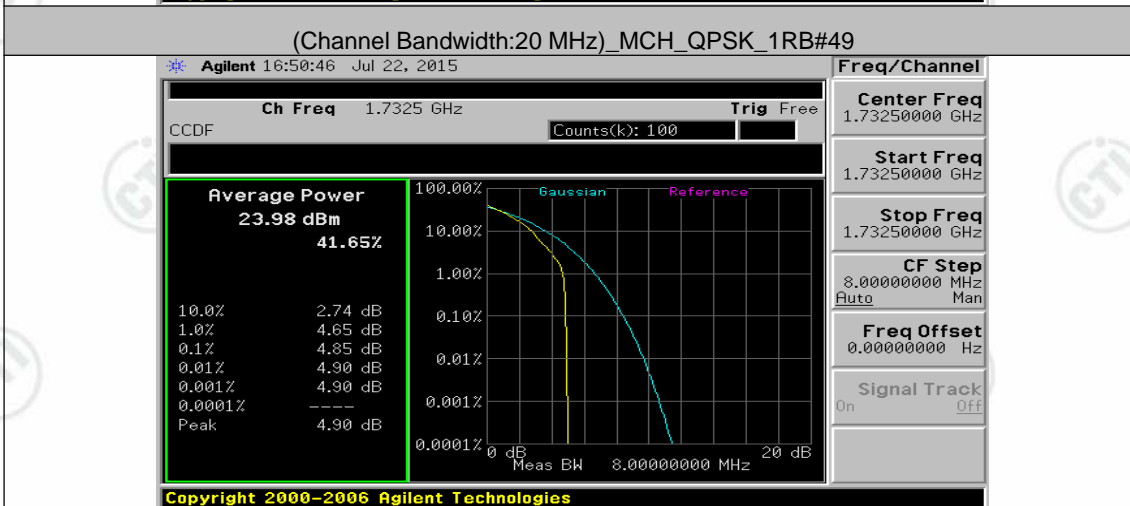
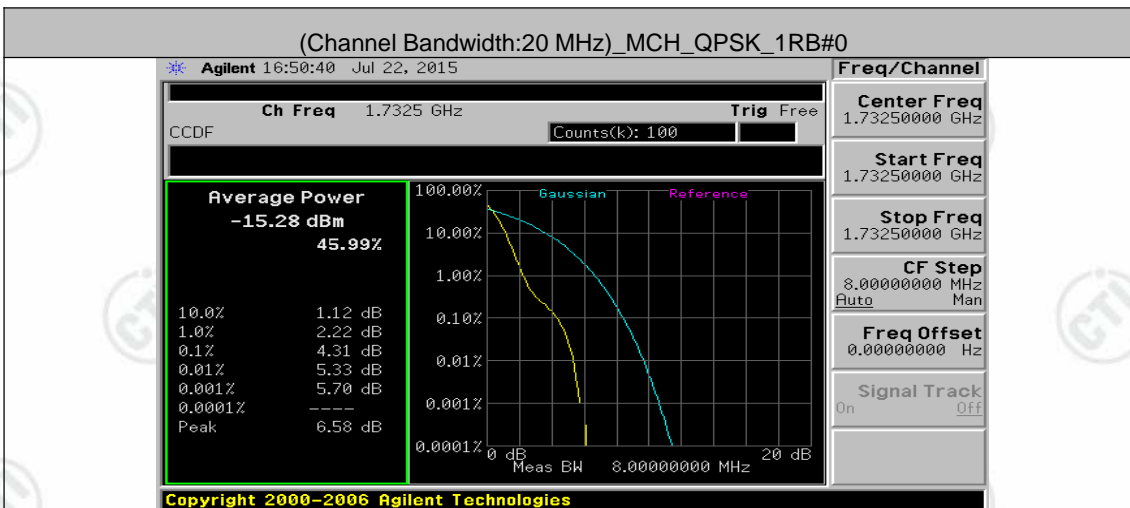
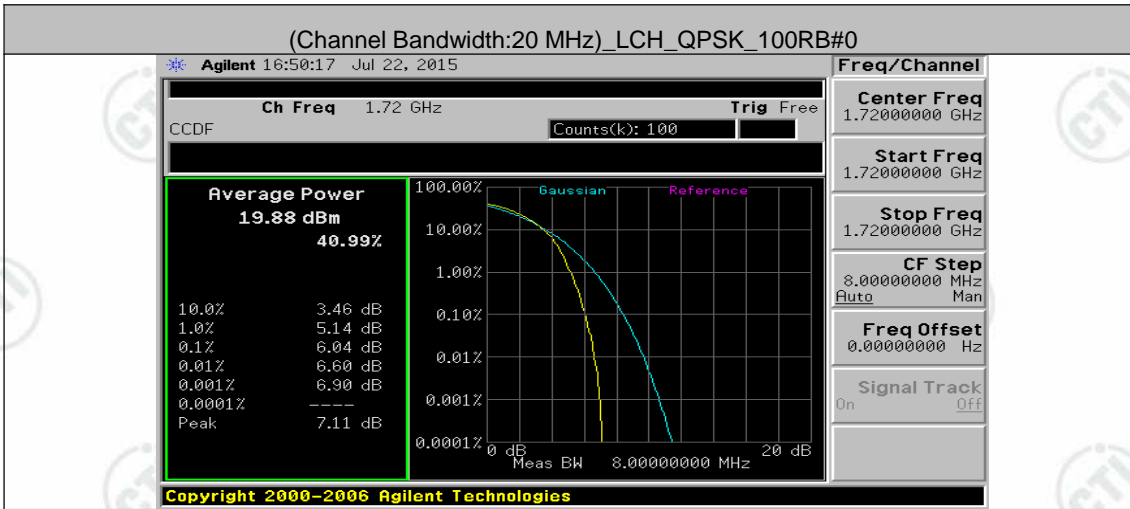

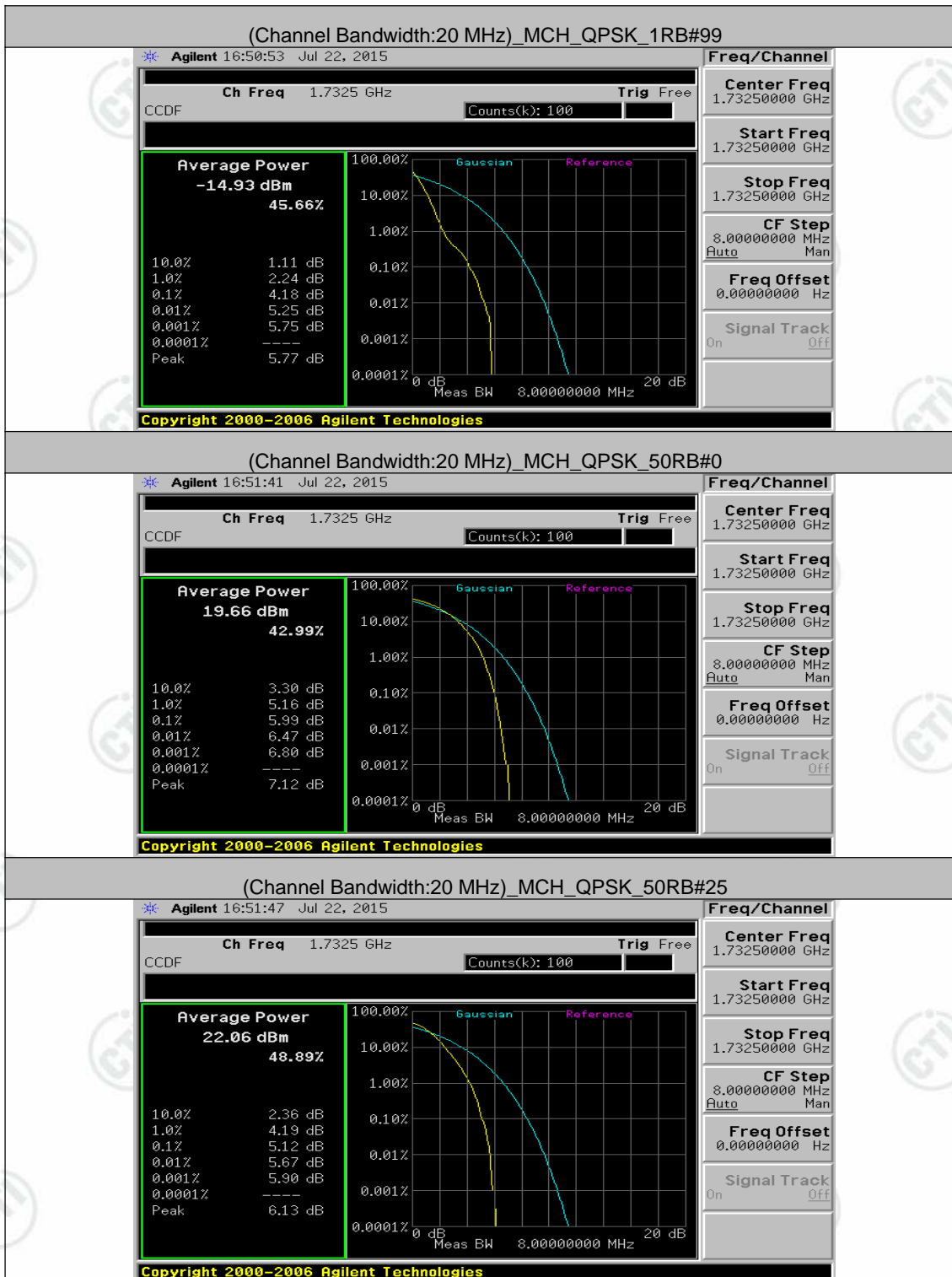

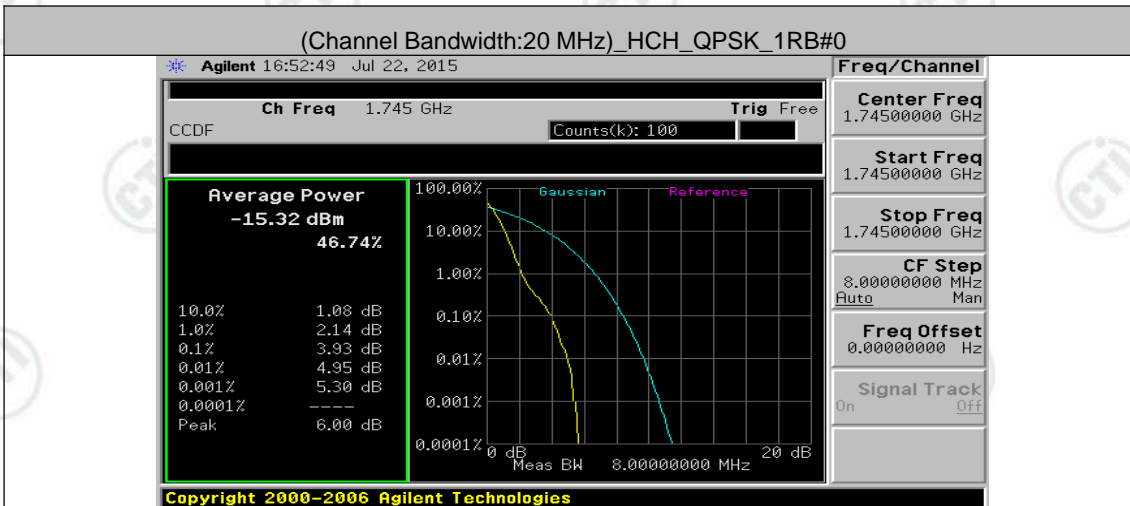
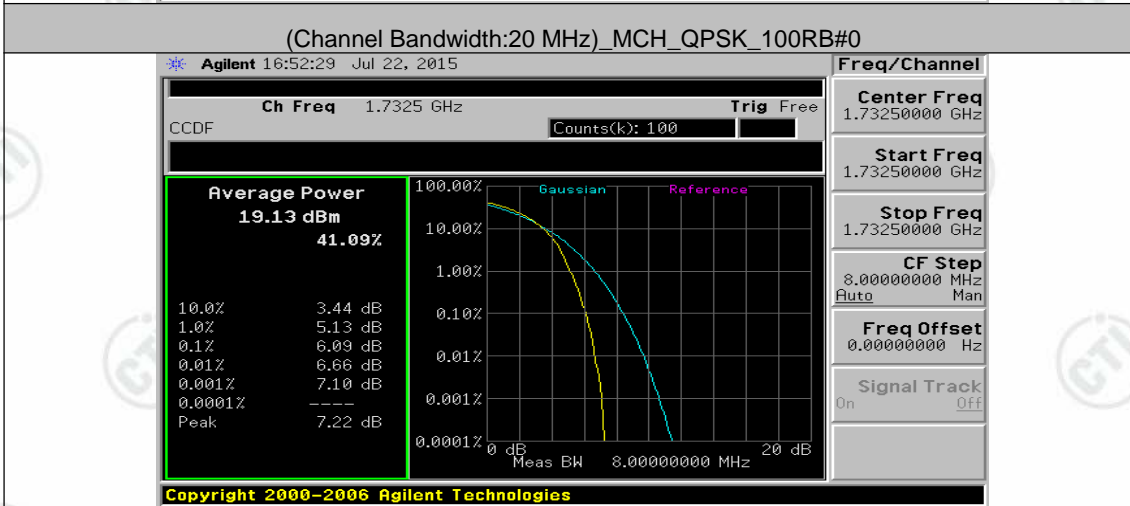
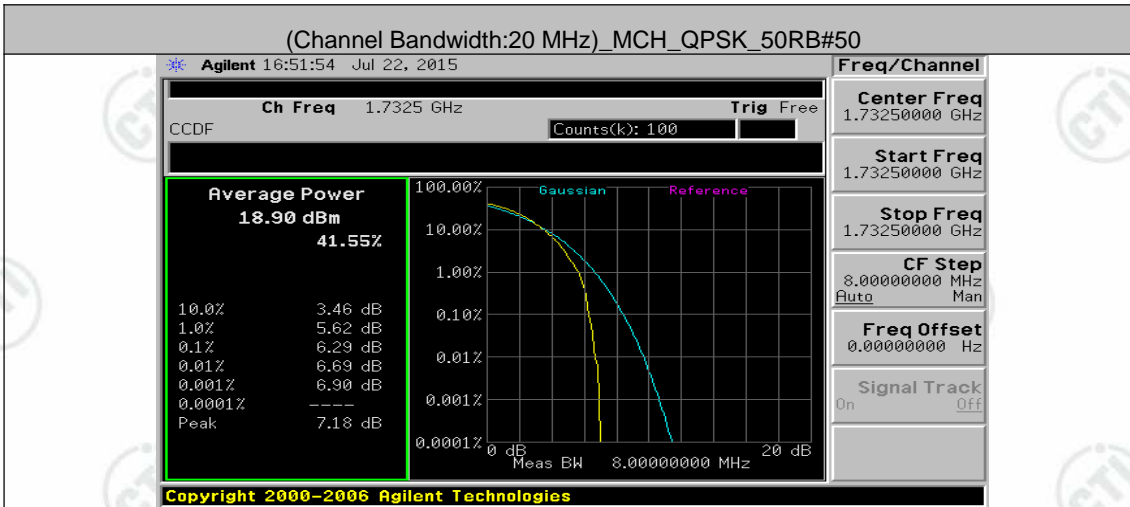



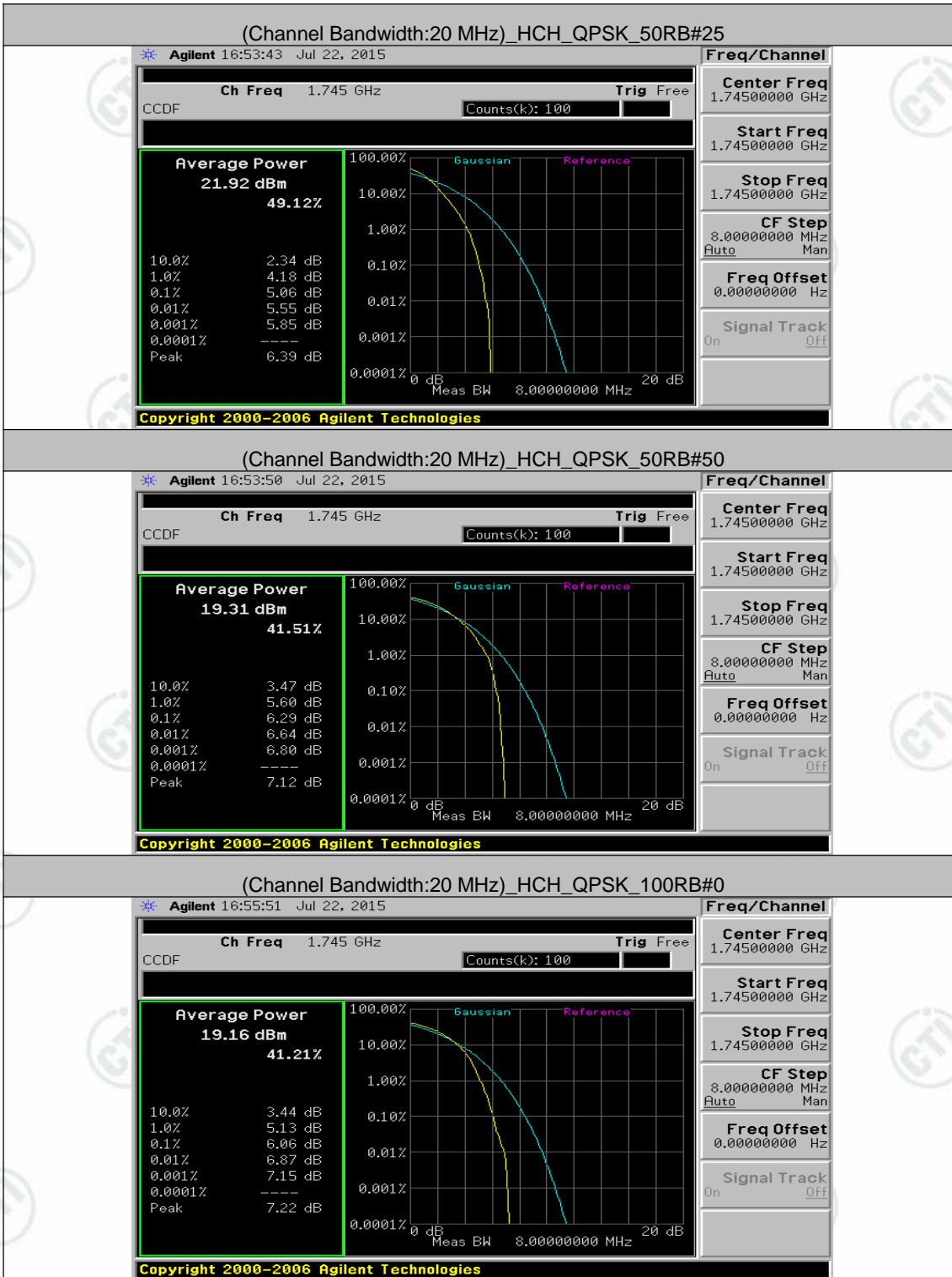



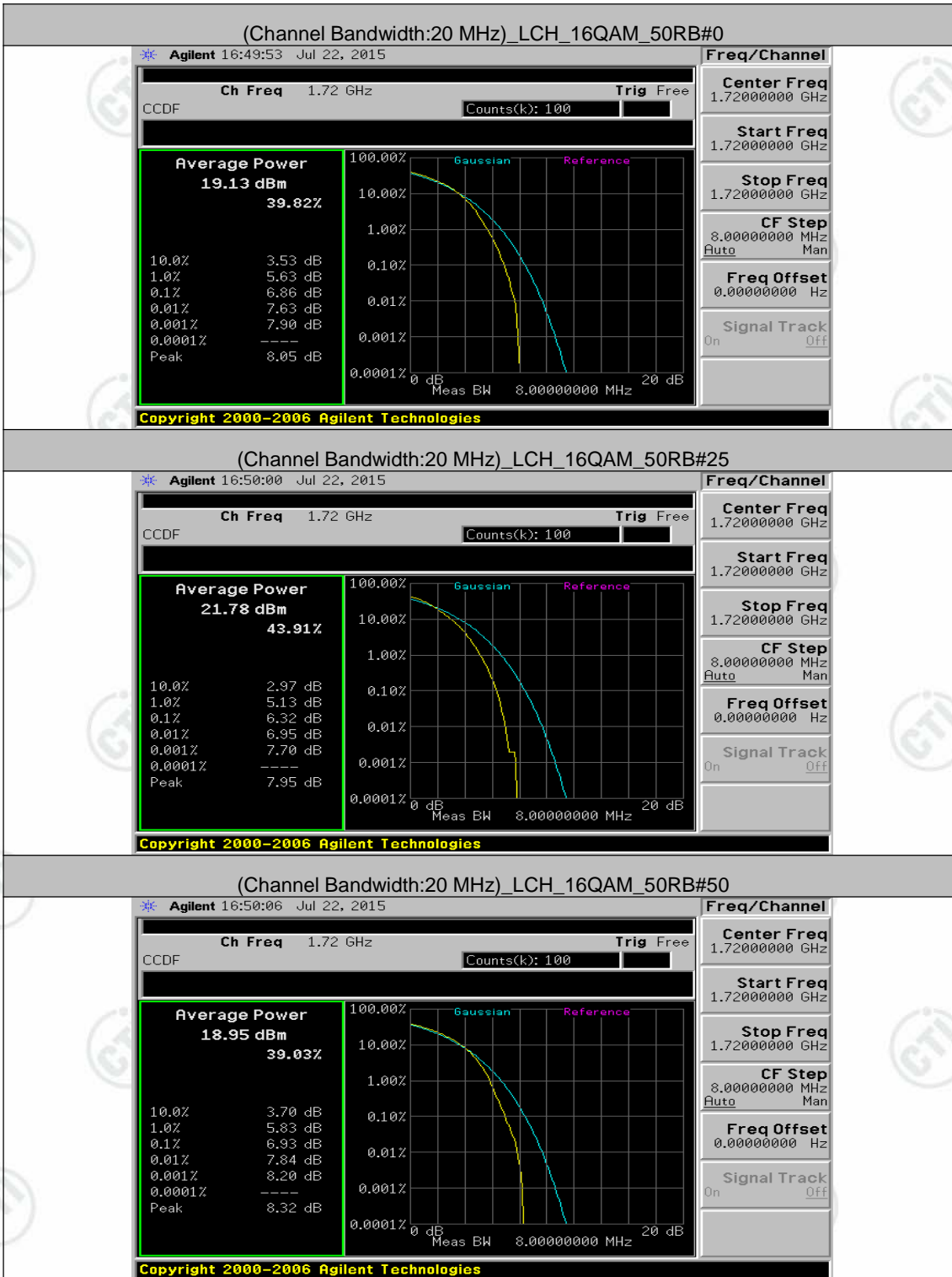

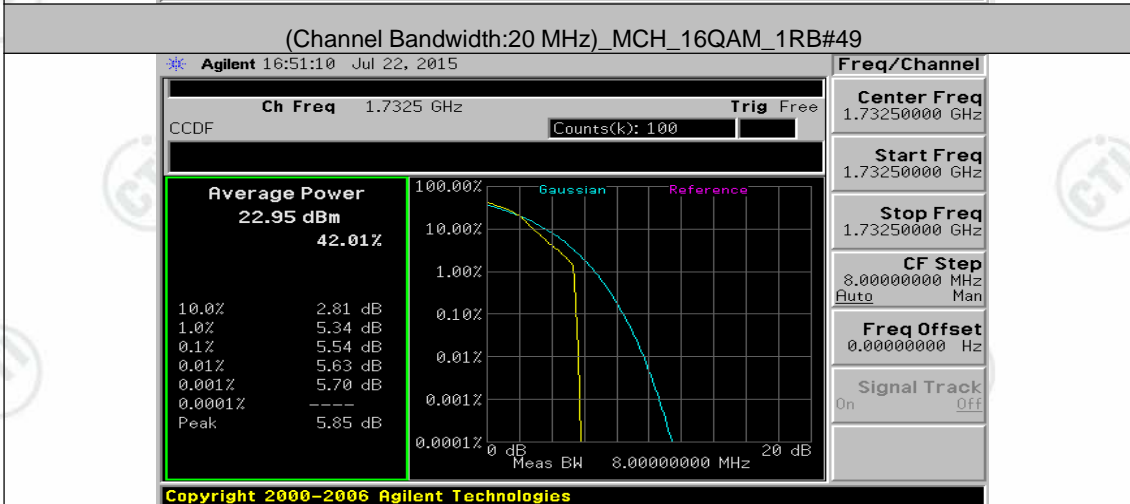
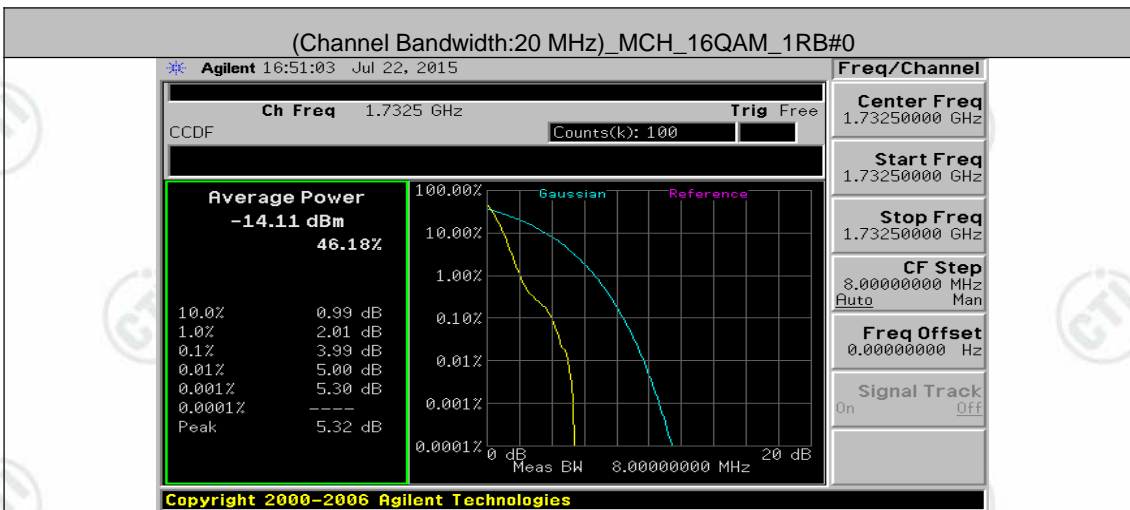
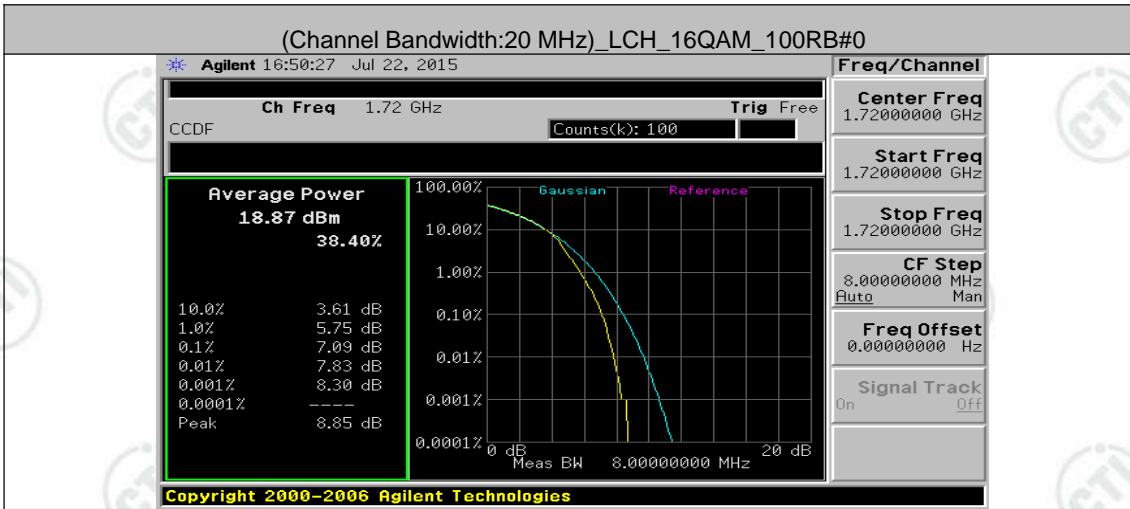

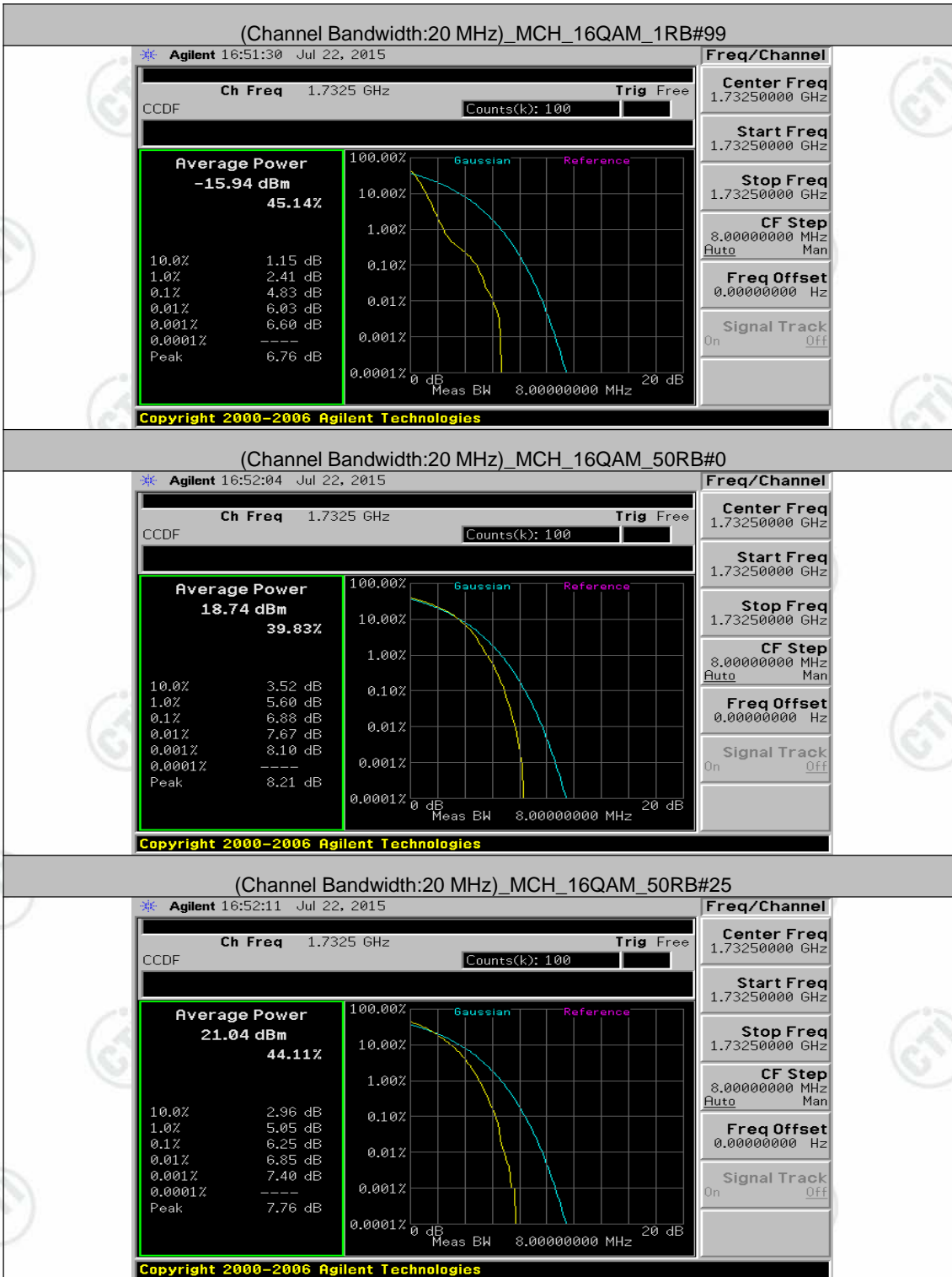

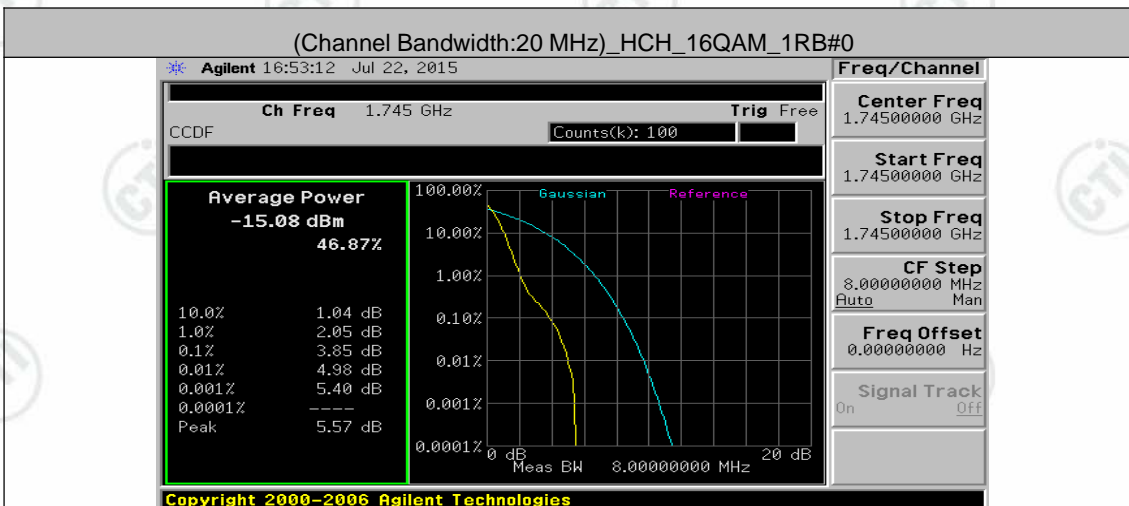
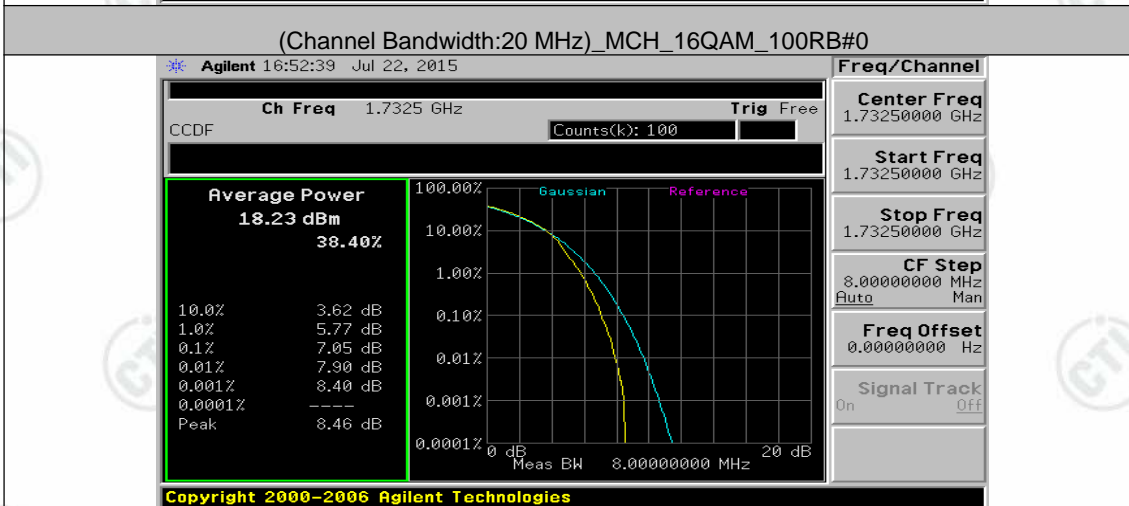
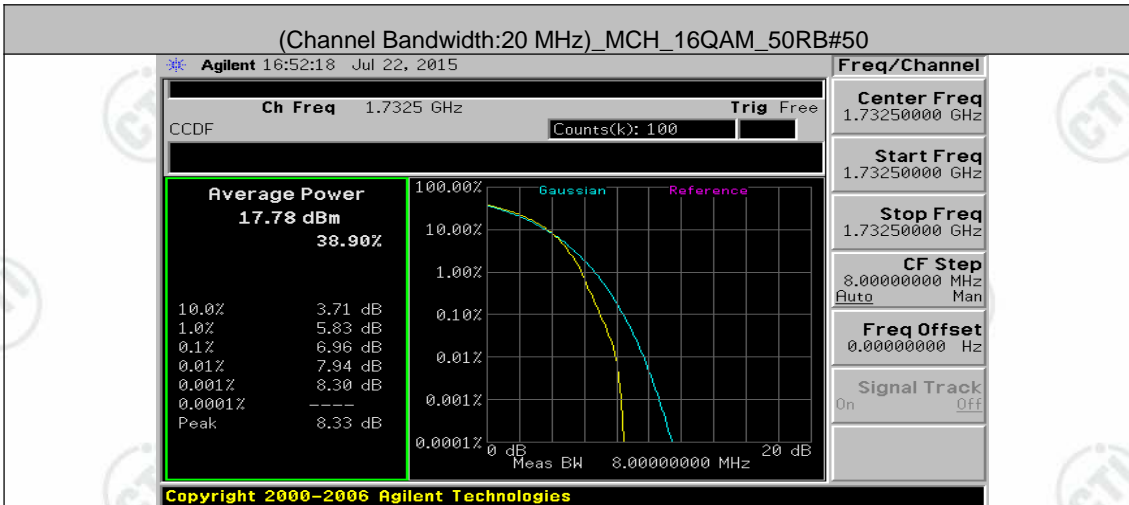



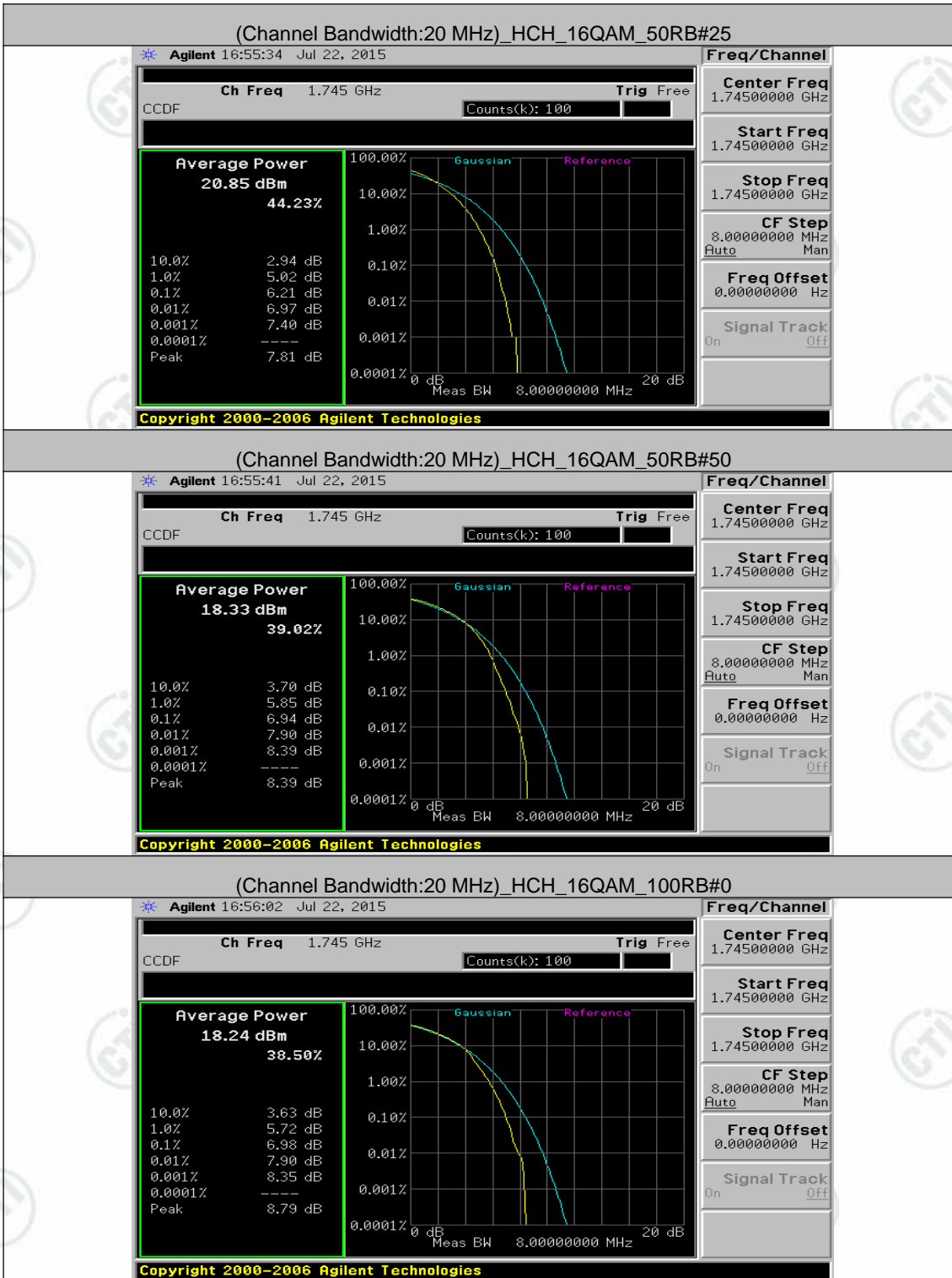

Appendix C: 26dB Bandwidth and Occupied Bandwidth

Test Result

Channel Bandwidth: 1.4 MHz

Channel Bandwidth: 1.4 MHz						
Modulation	Channel	RB Configuration		Occupied Bandwidth (MHz)	26dB Bandwidth (MHz)	Verdict
		Size	Offset			
QPSK	LCH	6	0	1.0781	1.256	PASS
	MCH	6	0	1.0811	1.264	PASS
	HCH	6	0	1.0772	1.264	PASS
16QAM	LCH	6	0	1.0838	1.269	PASS
	MCH	6	0	1.0837	1.256	PASS
	HCH	6	0	1.0817	1.263	PASS

Channel Bandwidth: 3 MHz

Channel Bandwidth: 3 MHz						
Modulation	Channel	RB Configuration		Occupied Bandwidth (MHz)	26dB Bandwidth (MHz)	Verdict
		Size	Offset			
QPSK	LCH	15	0	2.6803	2.937	PASS
	MCH	15	0	2.6791	2.922	PASS
	HCH	15	0	2.6747	2.956	PASS
16QAM	LCH	15	0	2.6811	2.957	PASS
	MCH	15	0	2.6798	2.945	PASS
	HCH	15	0	2.6800	2.960	PASS

Channel Bandwidth: 5 MHz

Channel Bandwidth: 5 MHz						
Modulation	Channel	RB Configuration		Occupied Bandwidth (MHz)	26dB Bandwidth (MHz)	Verdict
		Size	Offset			
QPSK	LCH	25	0	4.4779	4.948	PASS
	MCH	25	0	4.4854	4.950	PASS
	HCH	25	0	4.4903	4.967	PASS
16QAM	LCH	25	0	4.4754	4.962	PASS
	MCH	25	0	4.4849	4.957	PASS
	HCH	25	0	4.4813	4.945	PASS

Channel Bandwidth: 10 MHz

Channel Bandwidth: 10 MHz						
Modulation	Channel	RB Configuration		Occupied Bandwidth (MHz)	26dB Bandwidth (MHz)	Verdict
		Size	Offset			
QPSK	LCH	50	0	8.9334	9.748	PASS
	MCH	50	0	8.9283	9.721	PASS
	HCH	50	0	8.9317	9.742	PASS
16QAM	LCH	50	0	8.9271	9.798	PASS
	MCH	50	0	8.9289	9.717	PASS
	HCH	50	0	8.9355	9.782	PASS

Channel Bandwidth: 15 MHz

Channel Bandwidth: 15 MHz						
Modulation	Channel	RB Configuration		Occupied Bandwidth (MHz)	26dB Bandwidth (MHz)	Verdict
		Size	Offset			
QPSK	LCH	75	0	13.3953	14.564	PASS
	MCH	75	0	13.3969	14.544	PASS
	HCH	75	0	13.3891	14.596	PASS
16QAM	LCH	75	0	13.4296	14.574	PASS
	MCH	75	0	13.4052	14.522	PASS
	HCH	75	0	13.4108	14.514	PASS

Channel Bandwidth: 20 MHz

Channel Bandwidth: 20 MHz						
Modulation	Channel	RB Configuration		Occupied Bandwidth (MHz)	26dB Bandwidth (MHz)	Verdict
		Size	Offset			
QPSK	LCH	100	0	17.8453	19.065	PASS
	MCH	100	0	17.8436	19.094	PASS
	HCH	100	0	17.8382	19.152	PASS
16QAM	LCH	100	0	17.8166	19.175	PASS
	MCH	100	0	17.8446	19.141	PASS
	HCH	100	0	17.8187	19.163	PASS

Test Graphs

Channel Bandwidth: 1.4 MHz

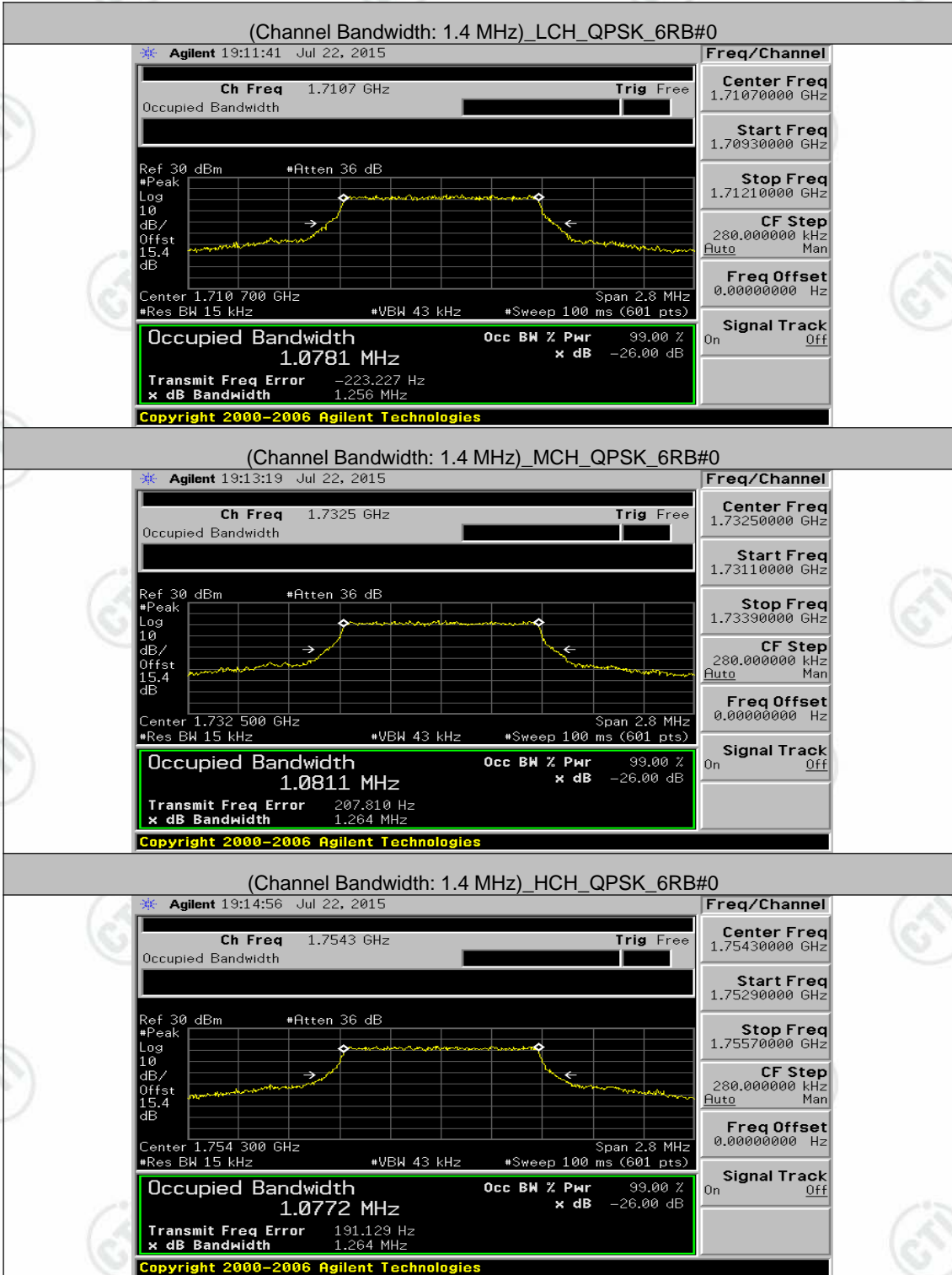

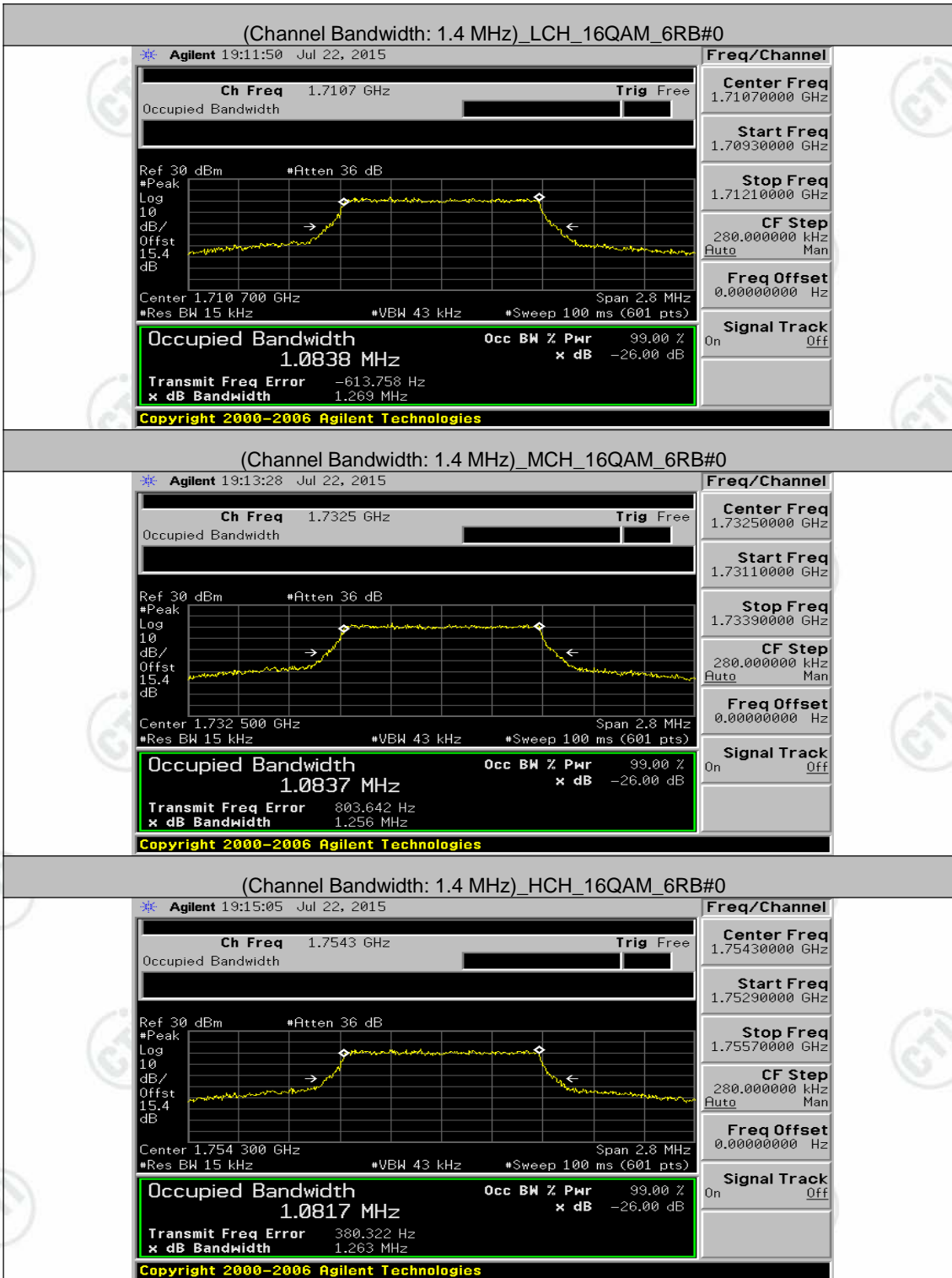

Channel Bandwidth: 3 MHz

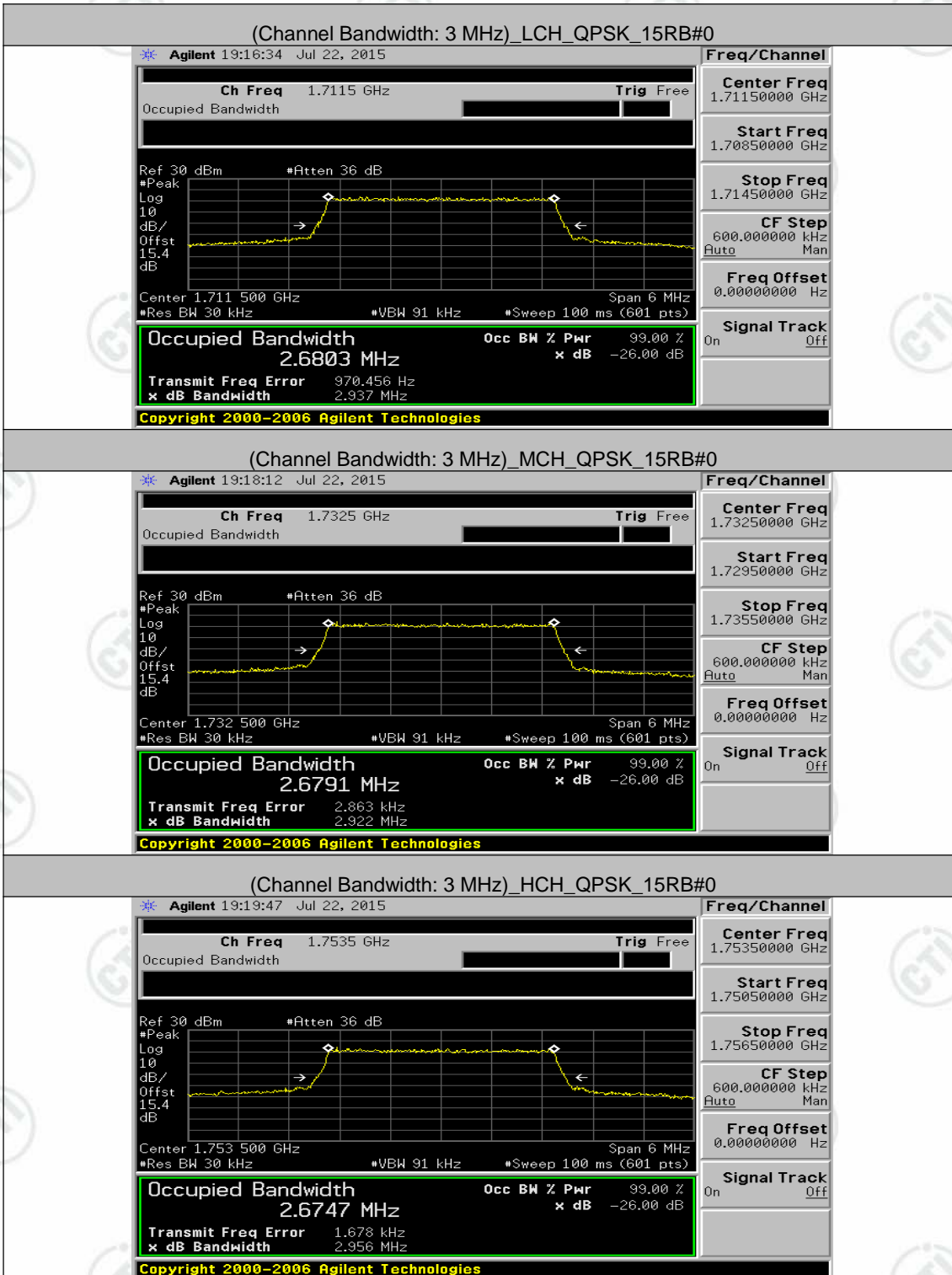

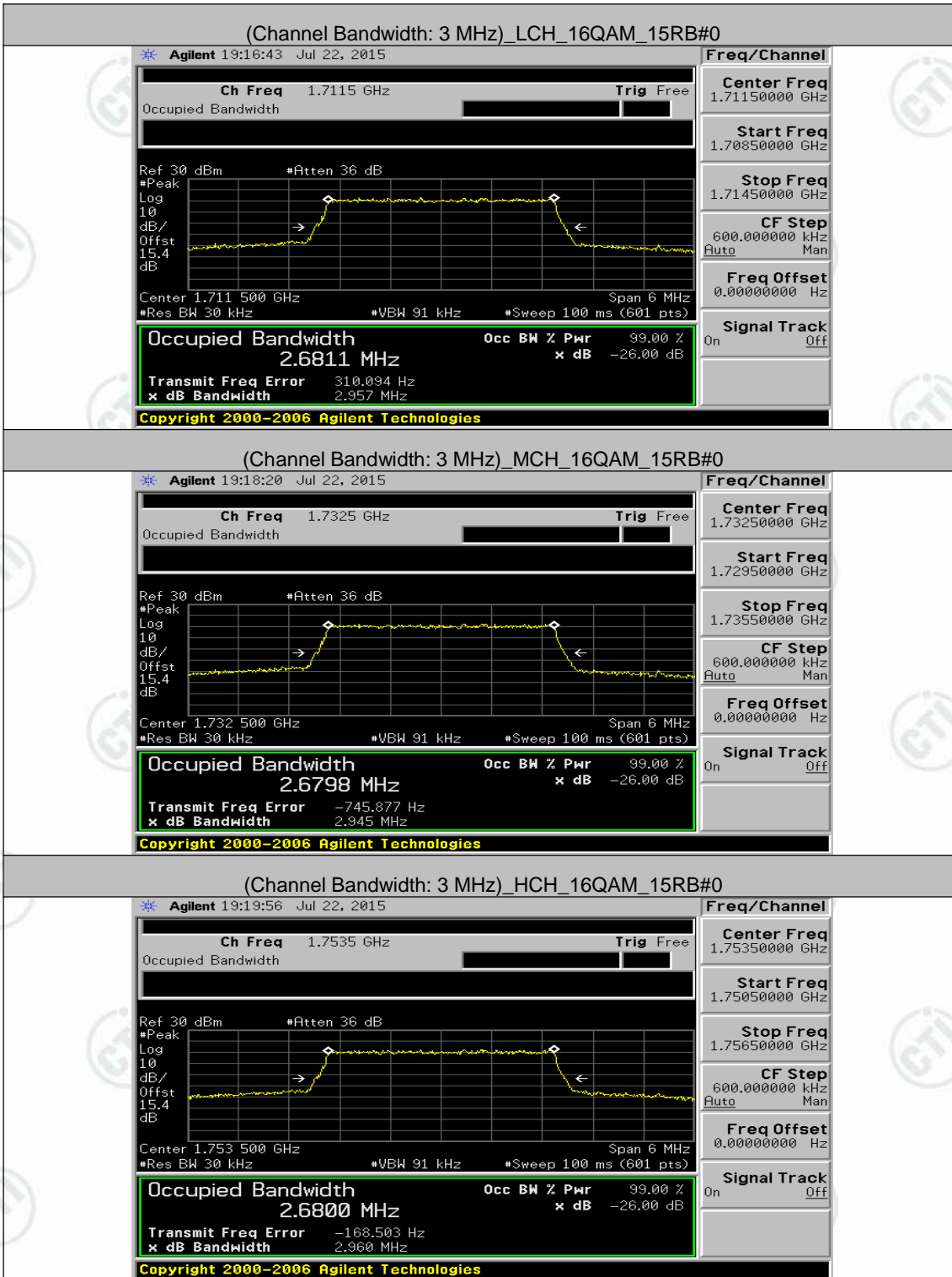

Channel Bandwidth: 5 MHz

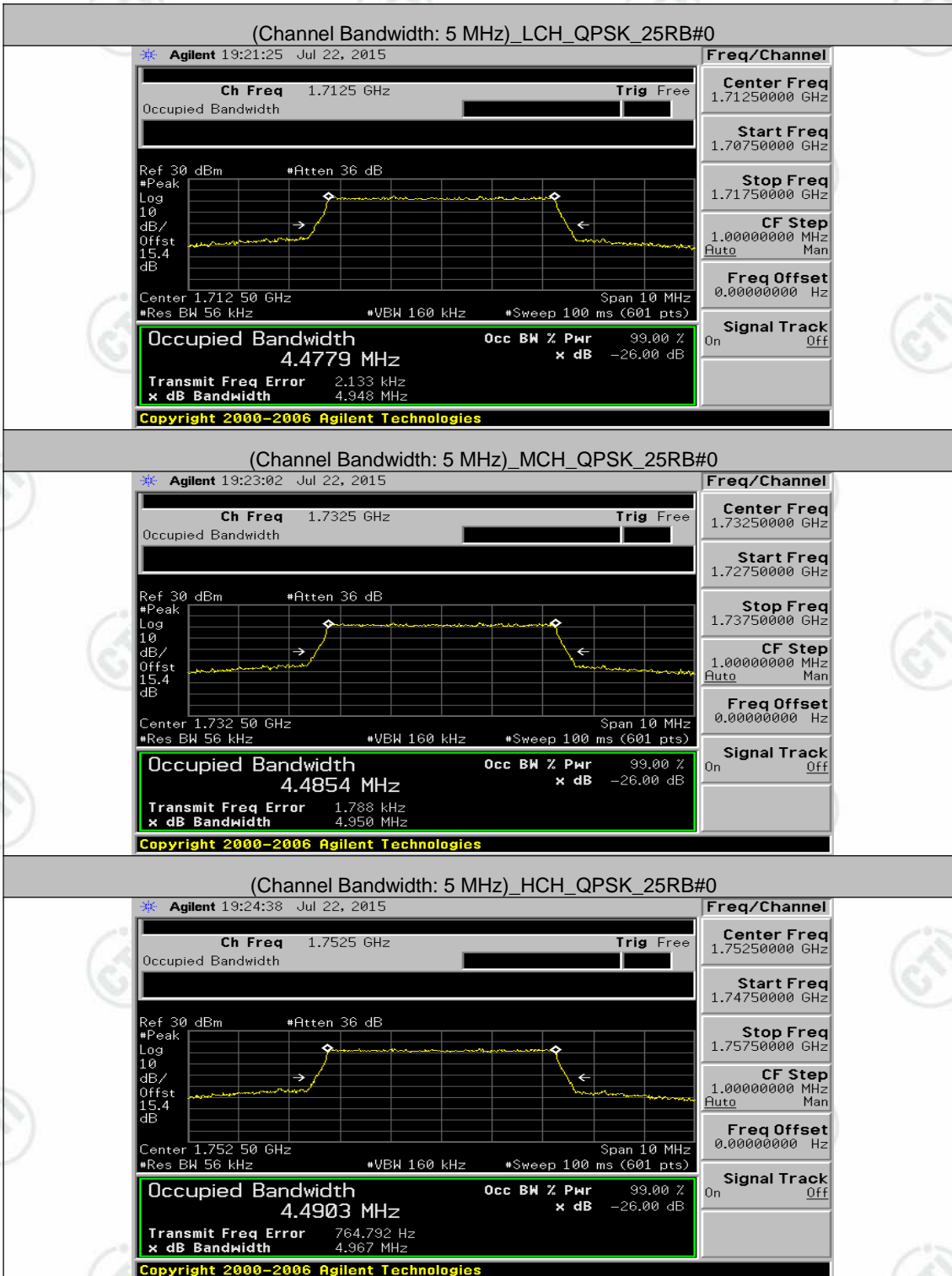

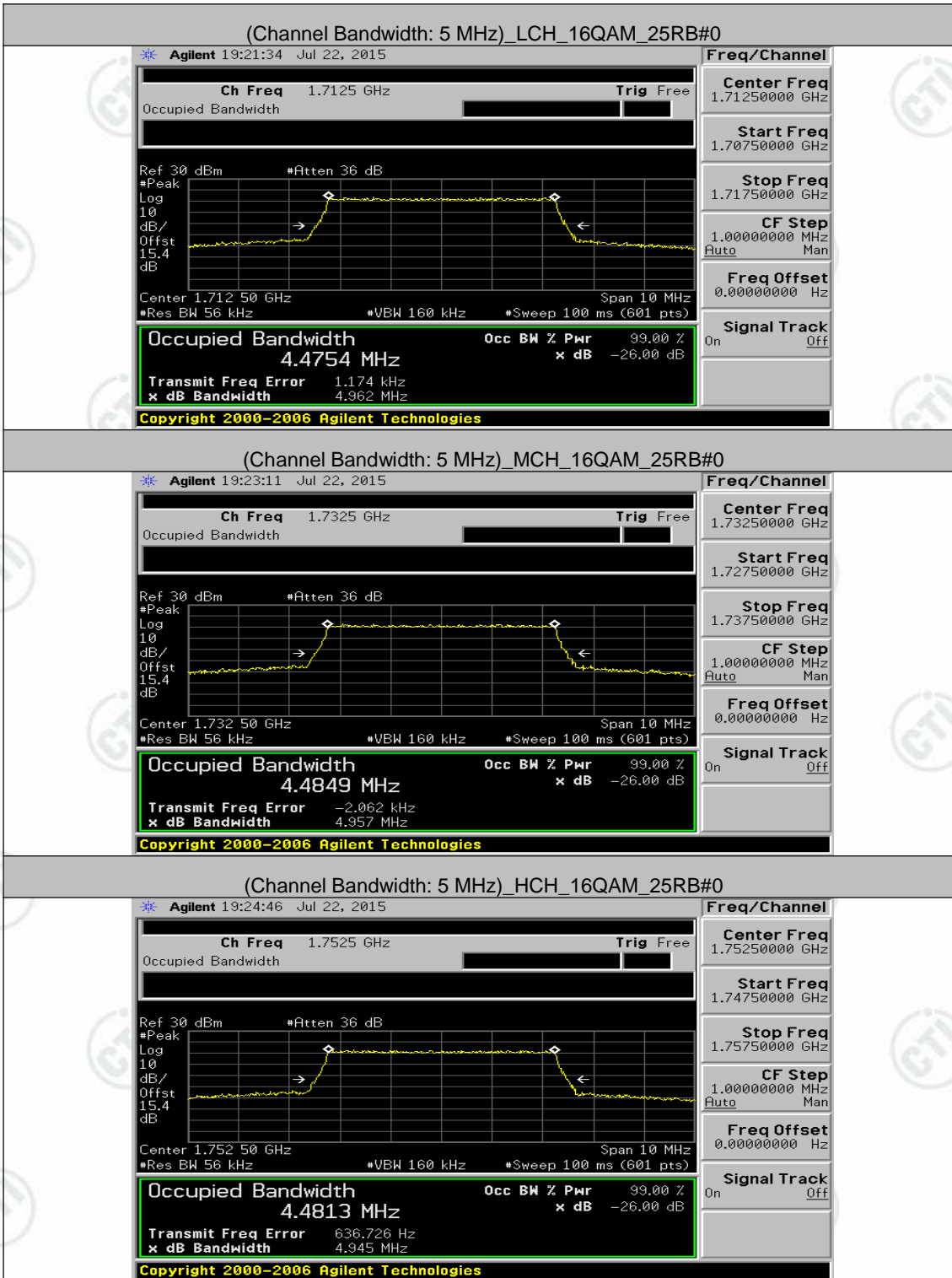

Channel Bandwidth: 10 MHz

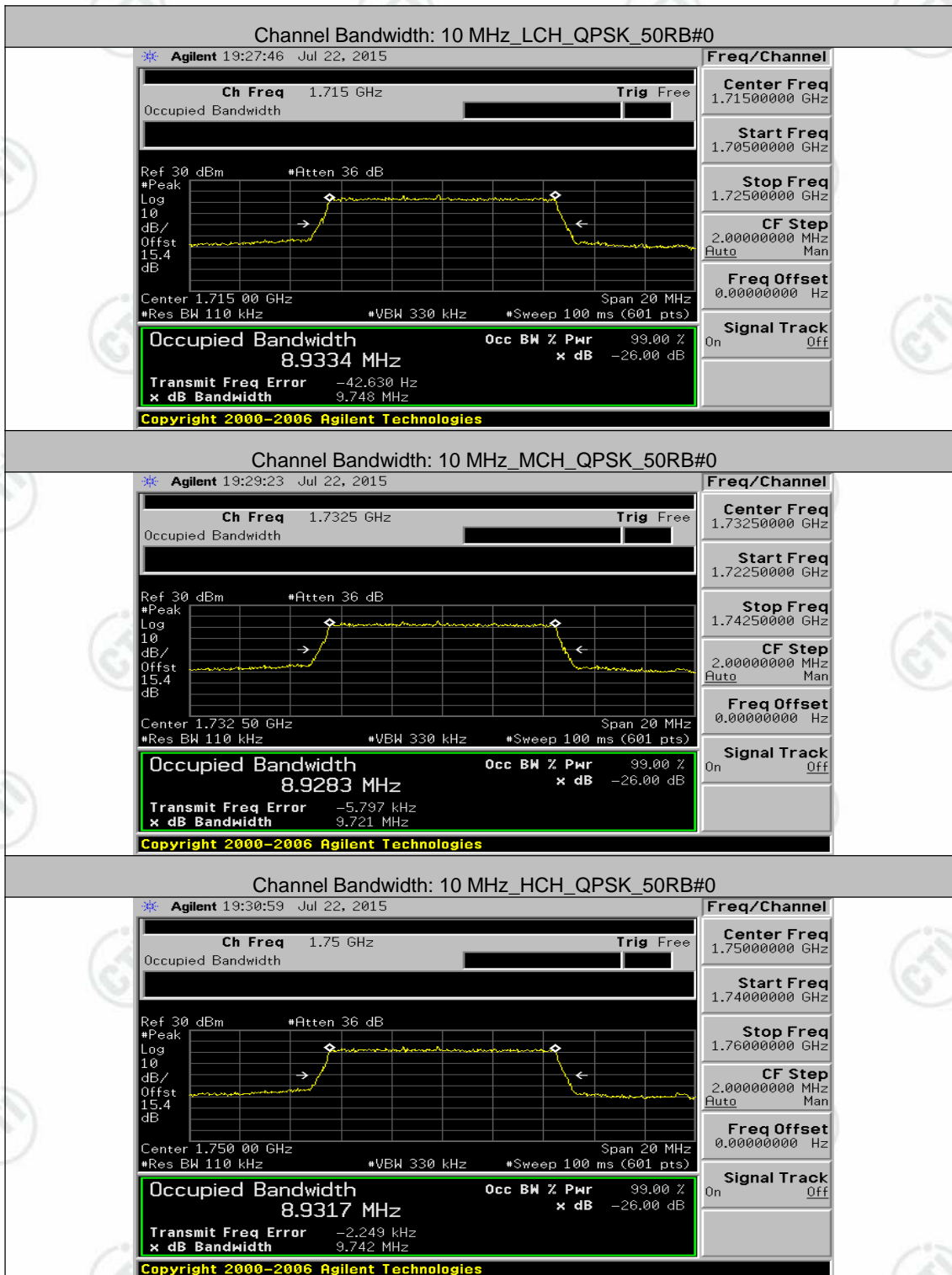

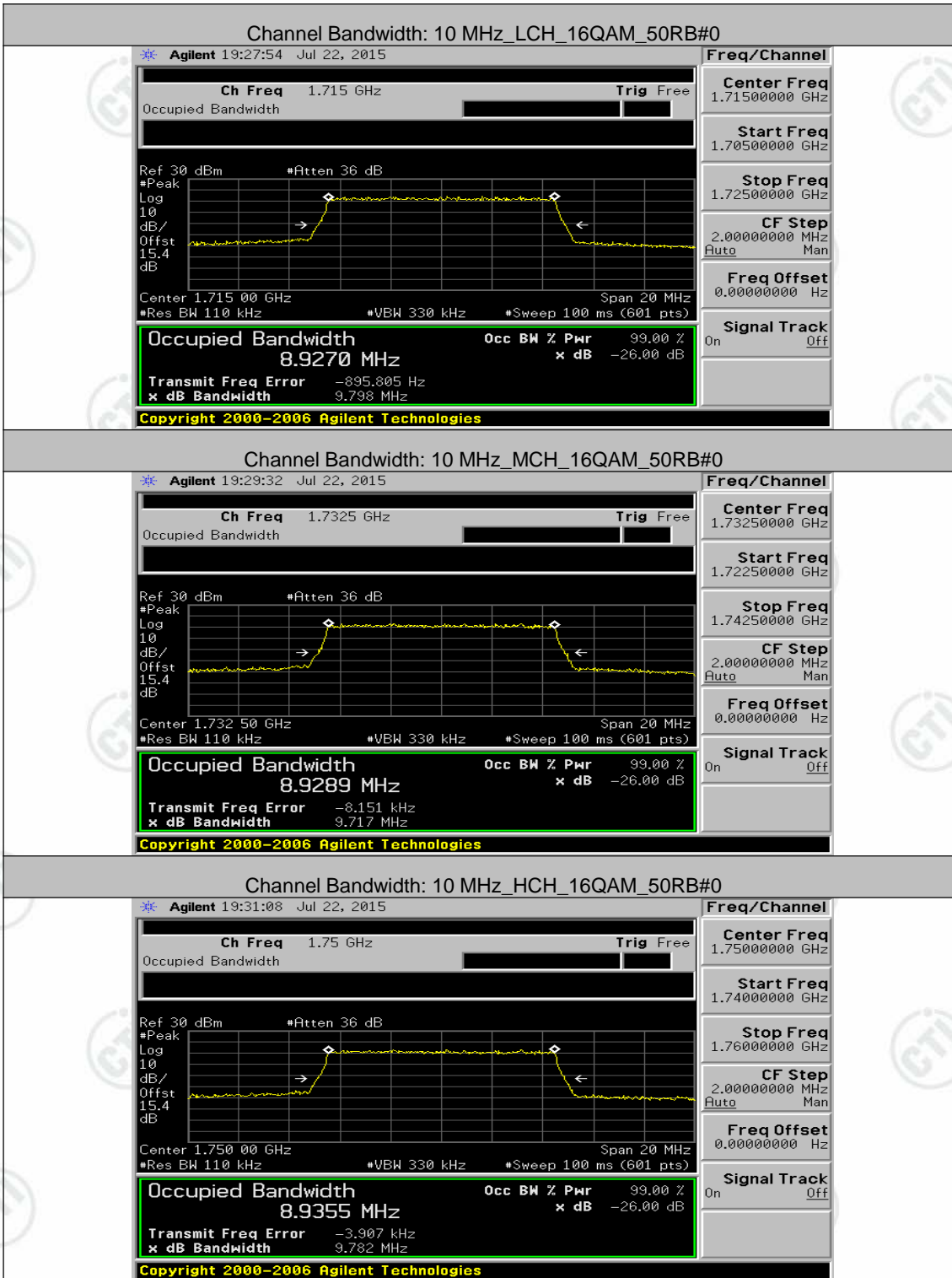

Channel Bandwidth: 15 MHz

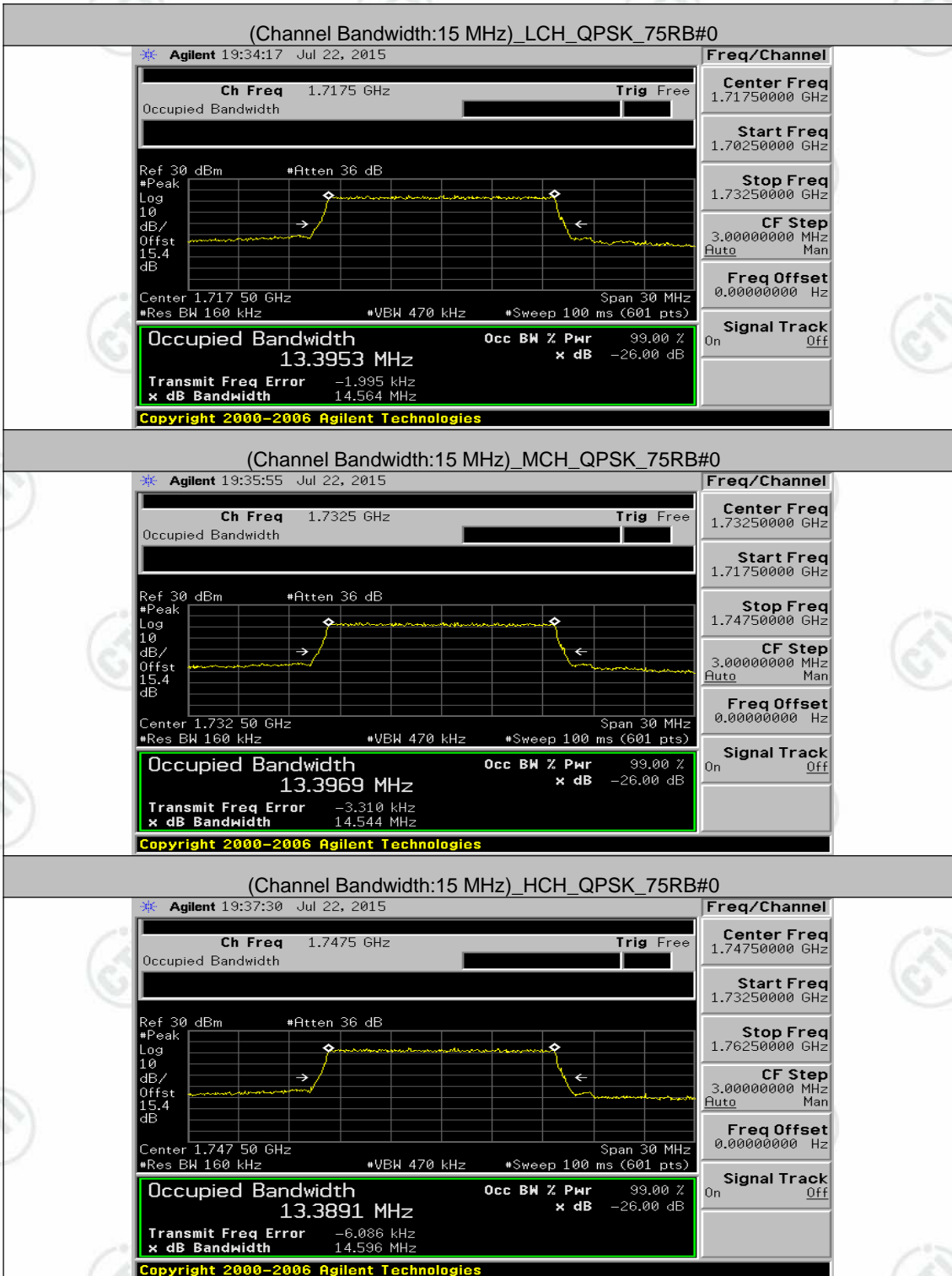

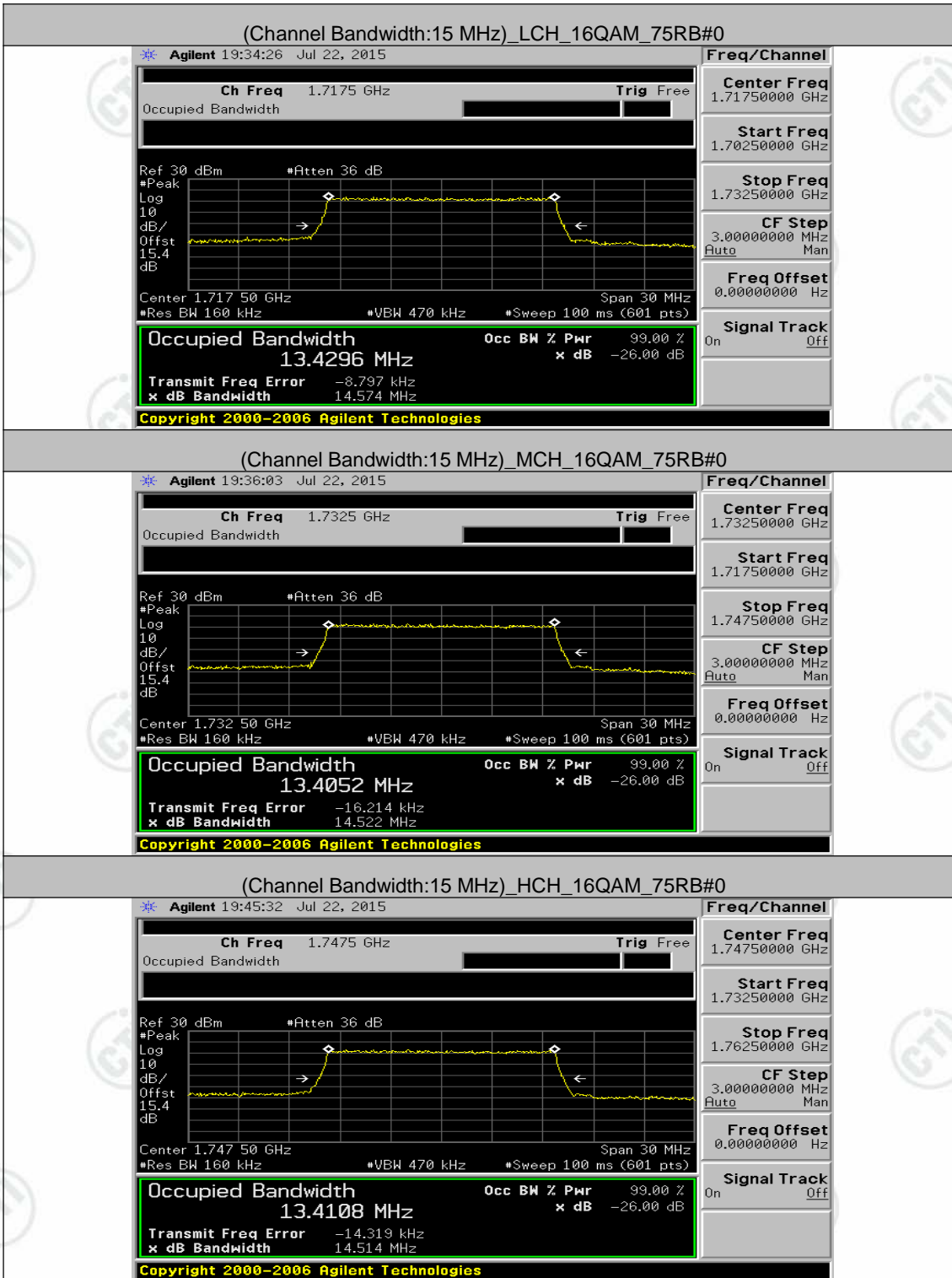

Channel Bandwidth: 20 MHz

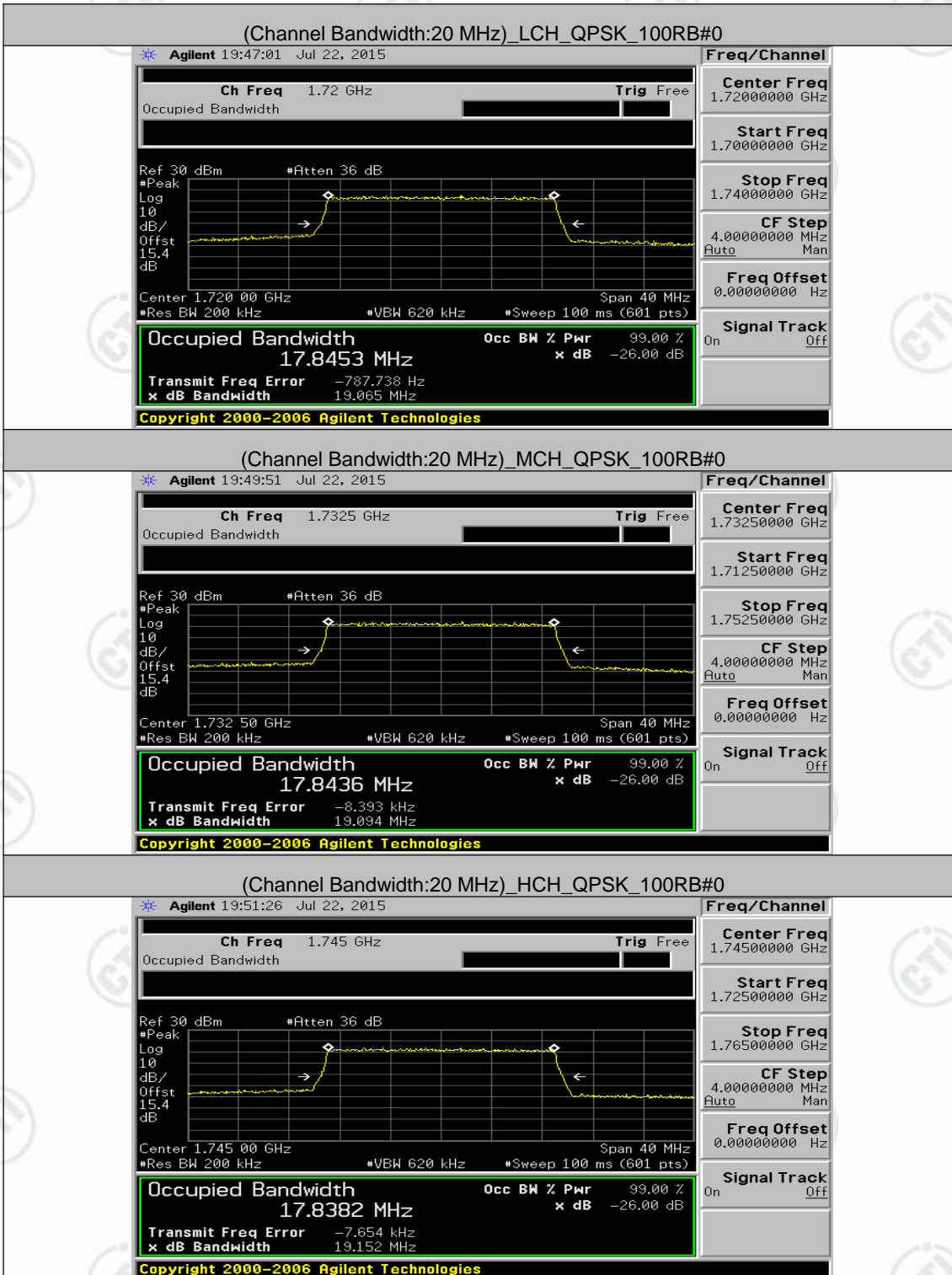

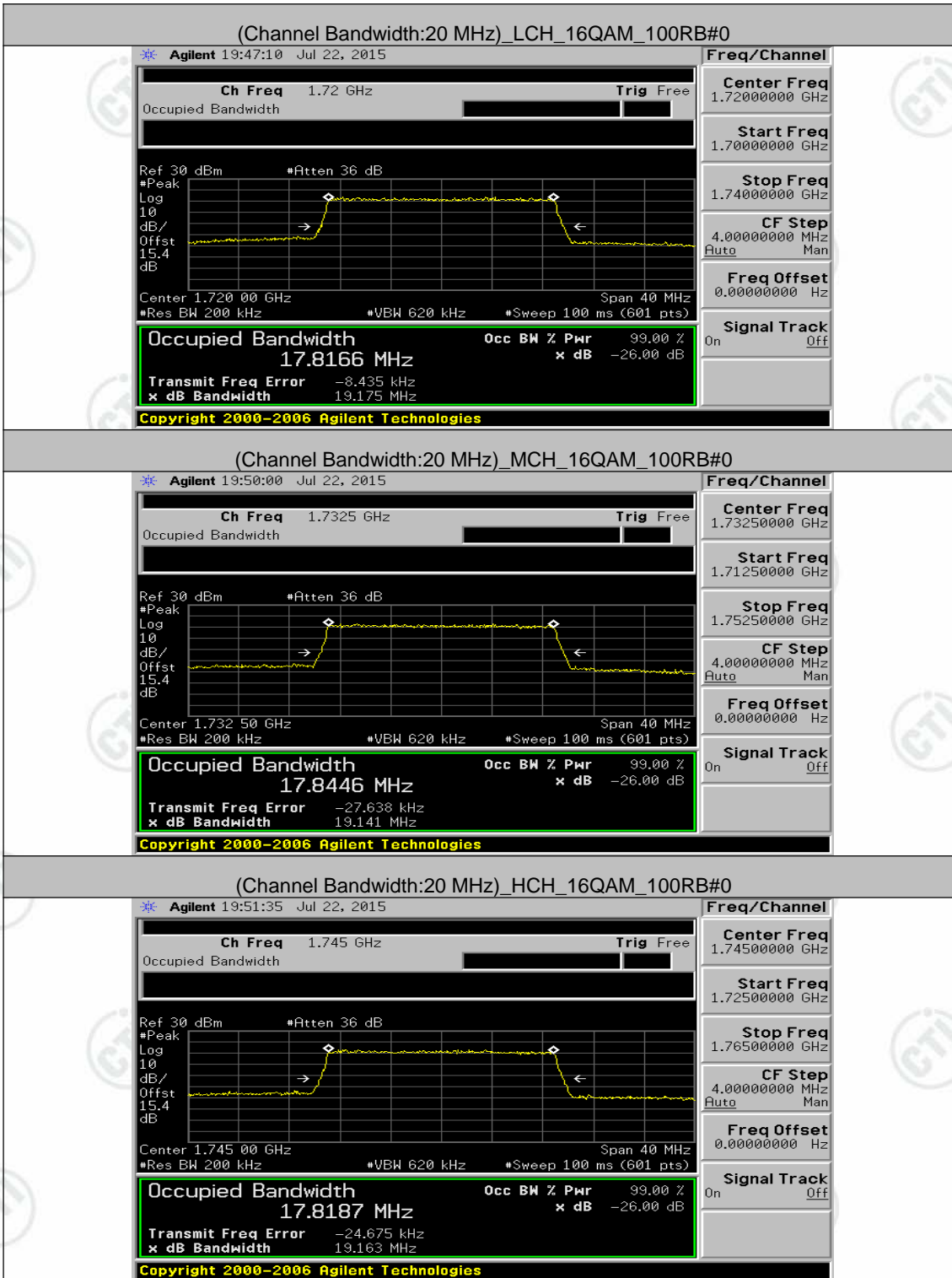

Appendix D: Band Edge

Test Graphs

Channel Bandwidth: 1.4 MHz

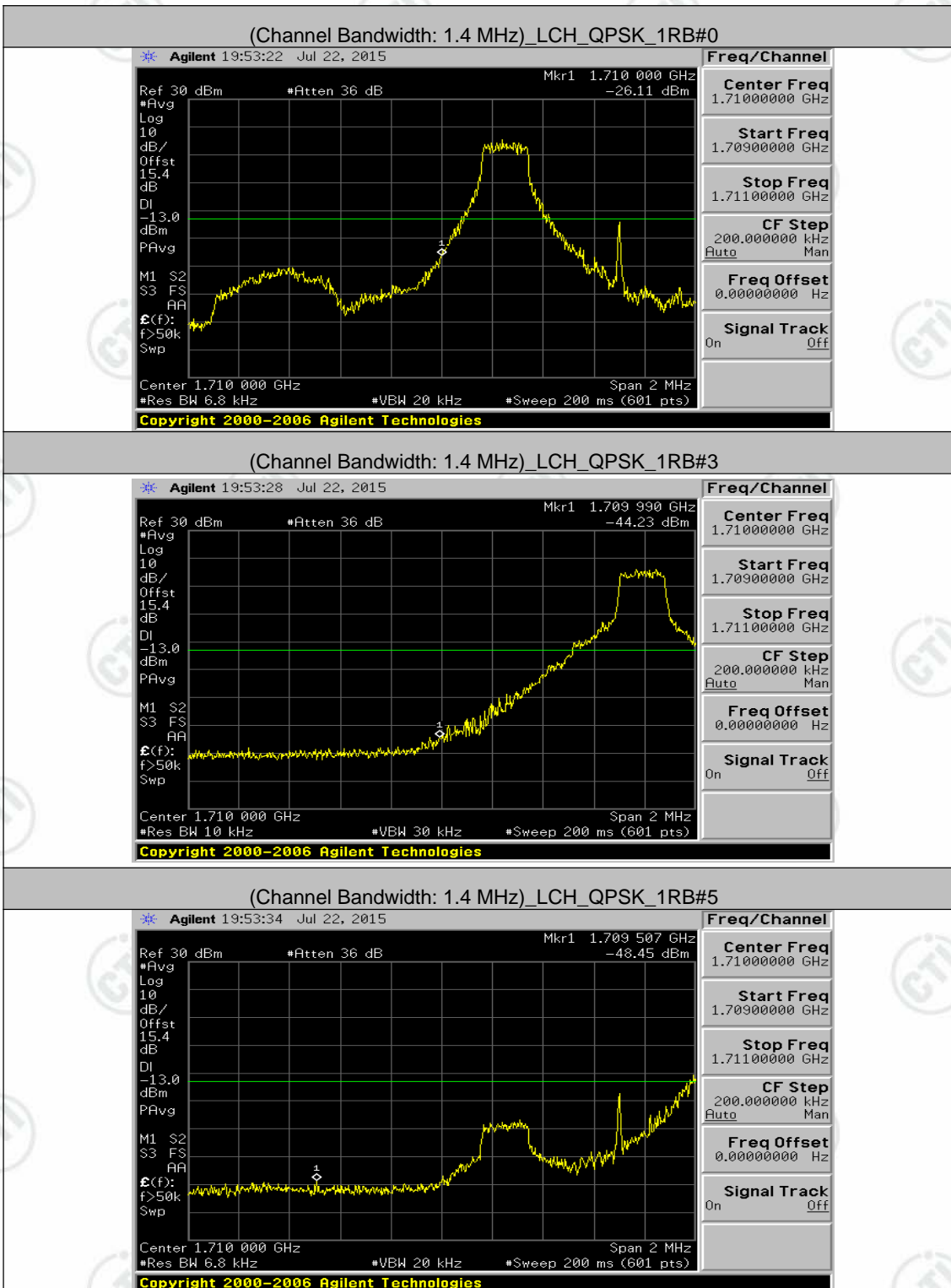

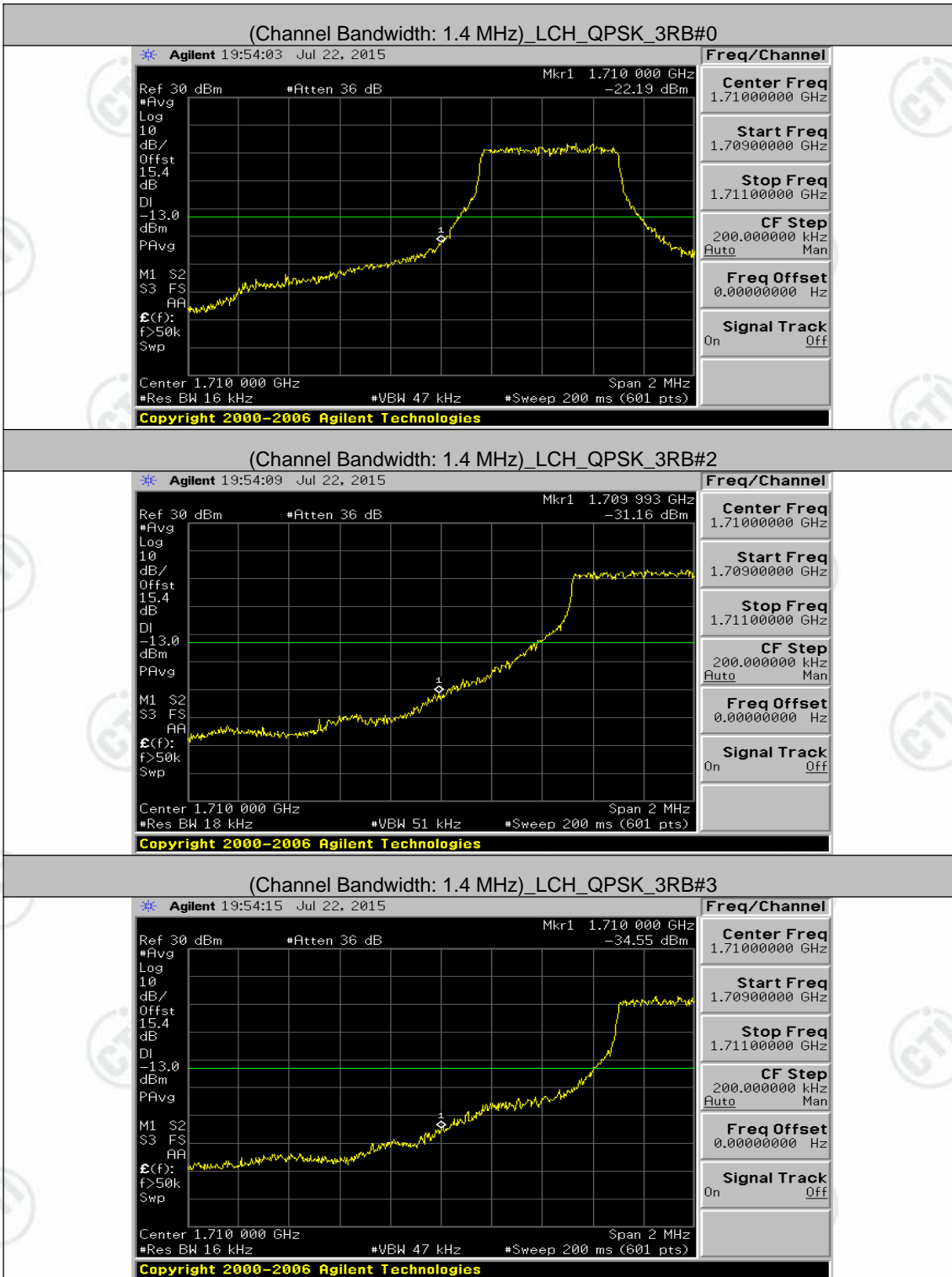

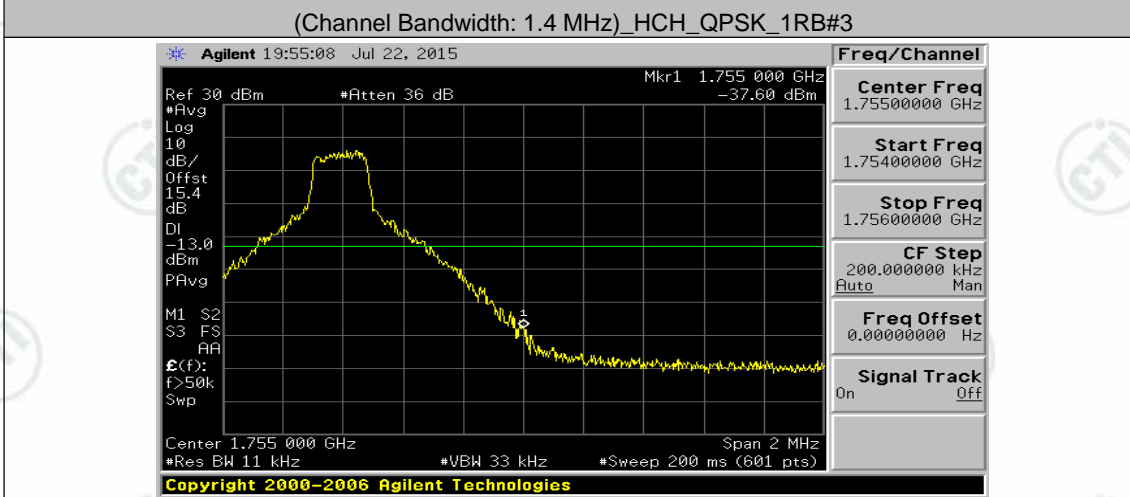
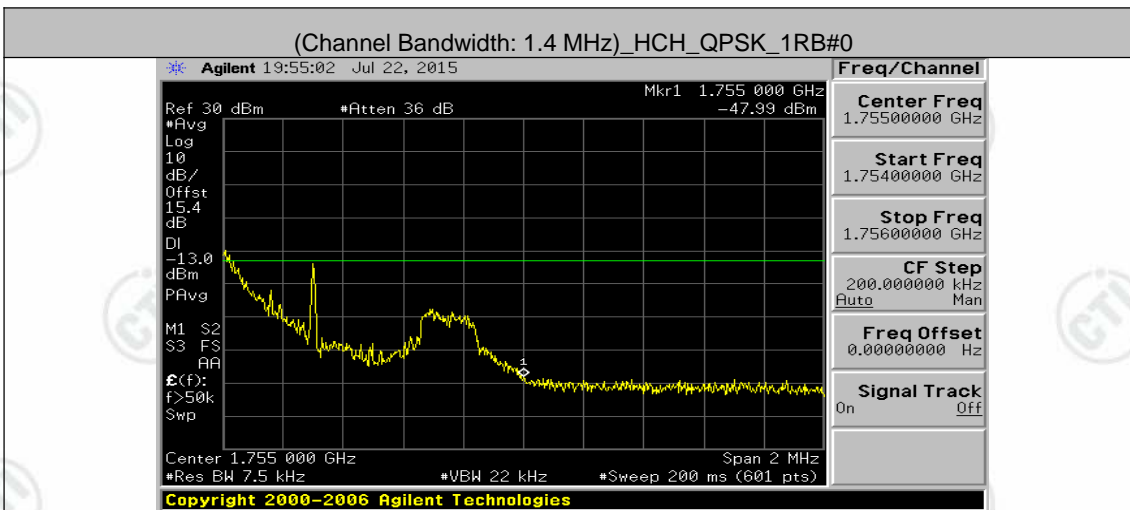
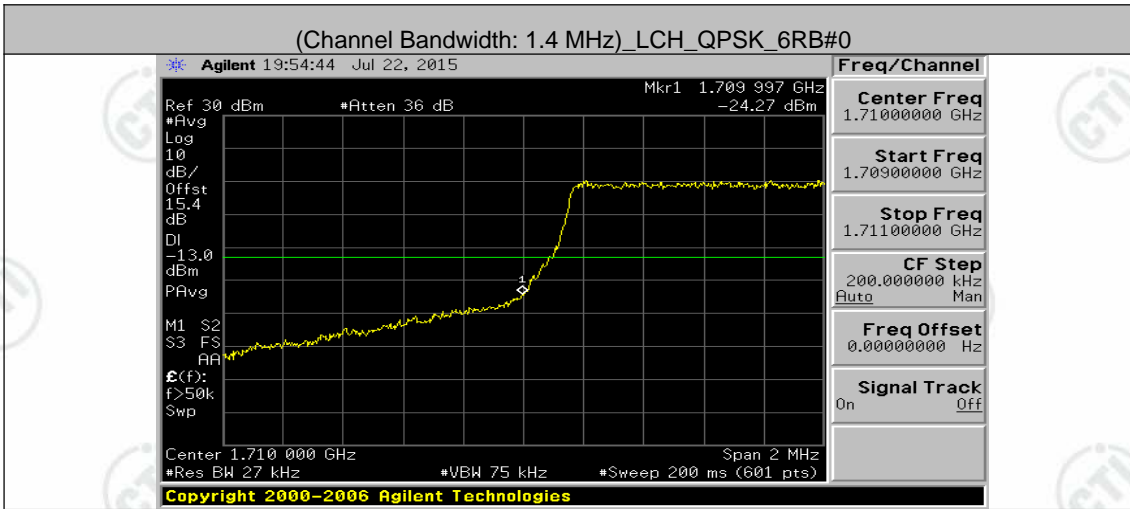

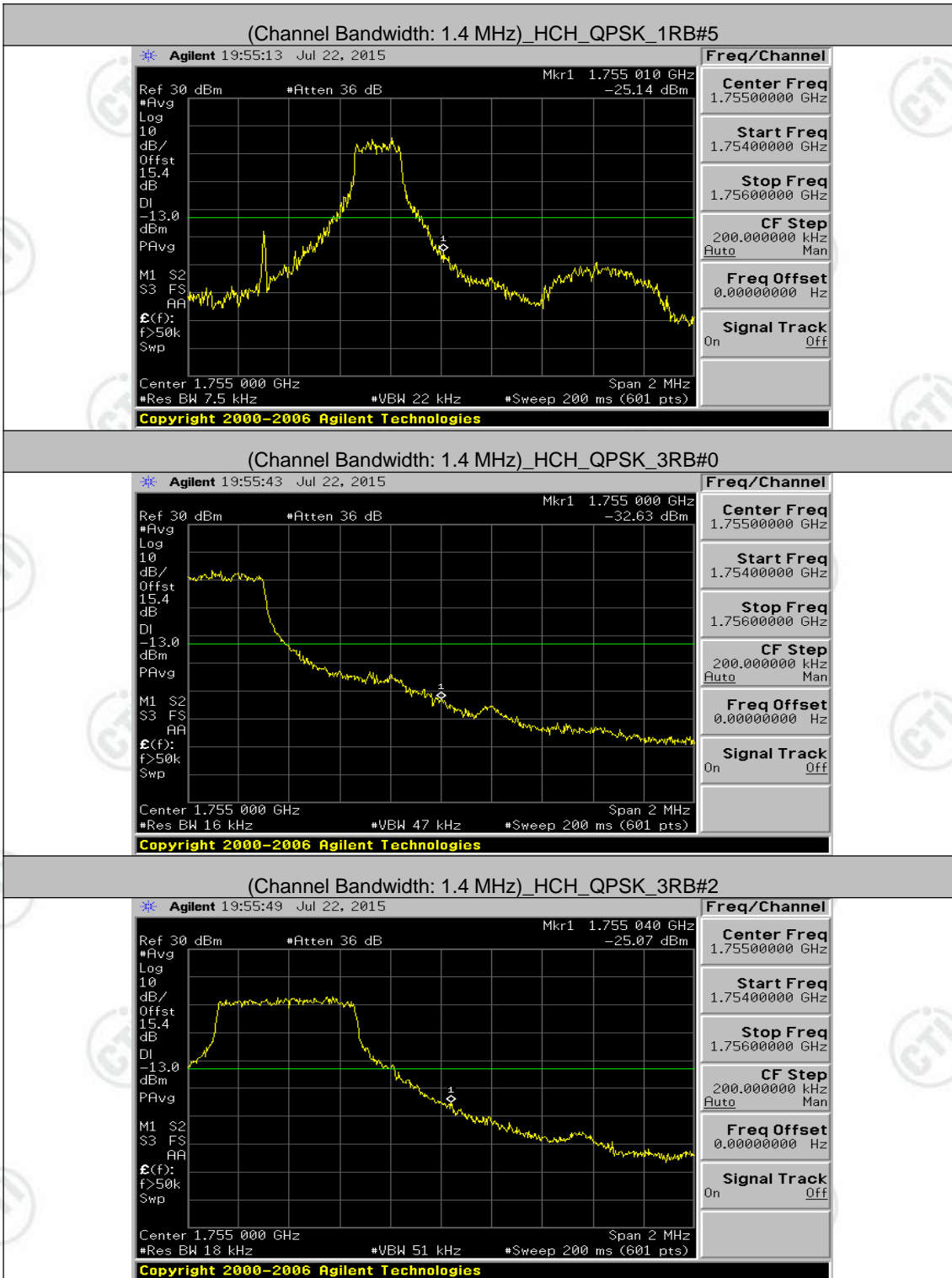

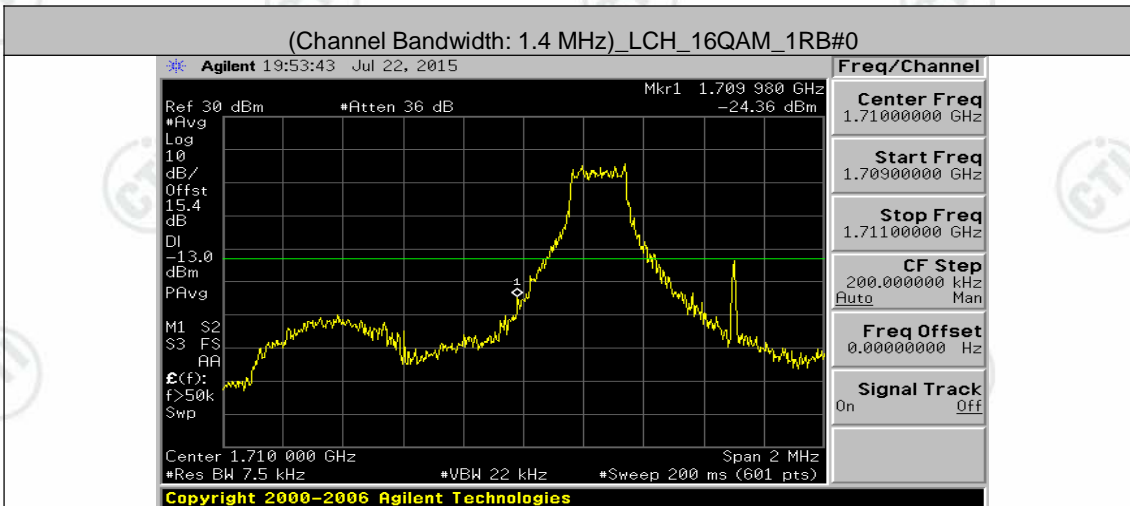
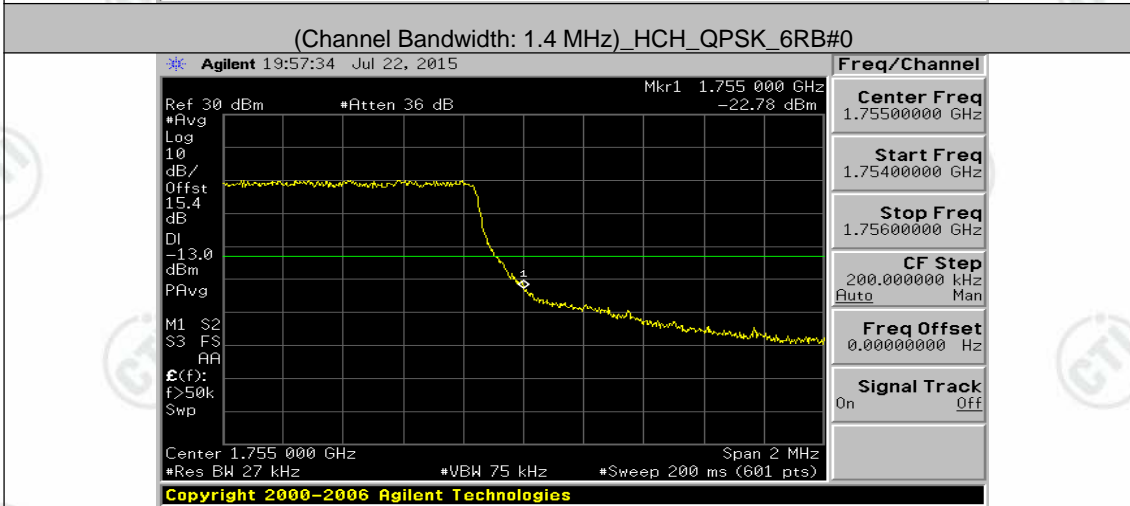
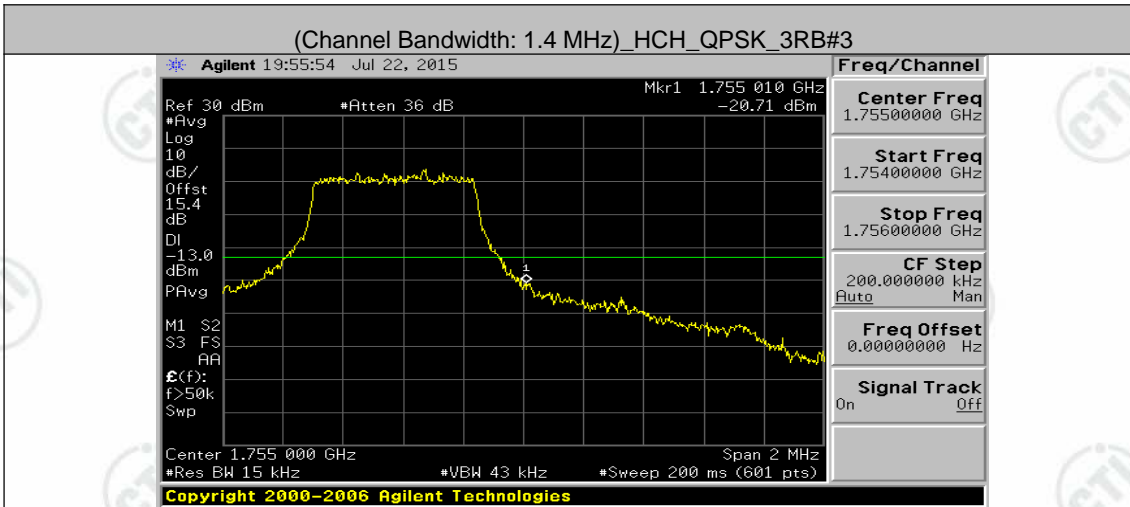

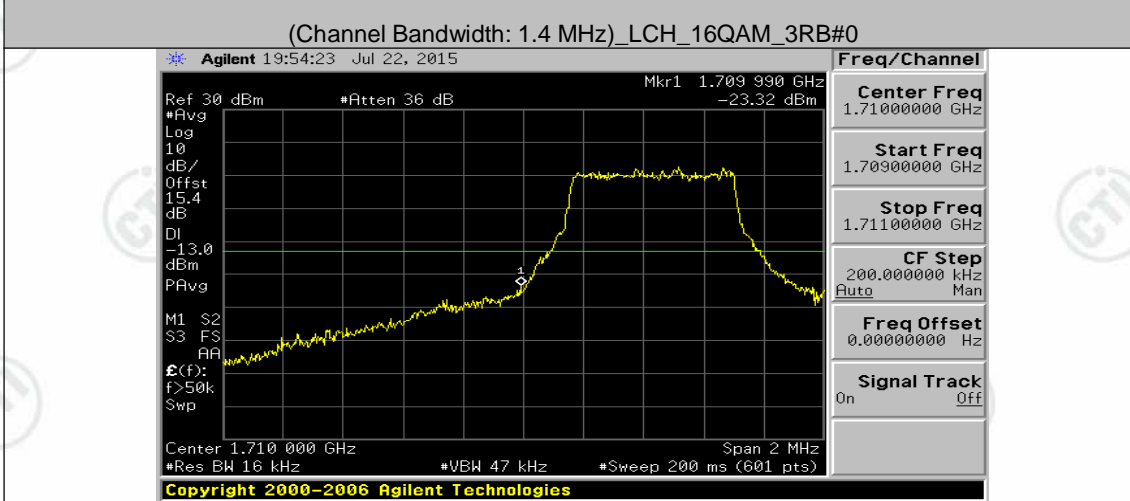
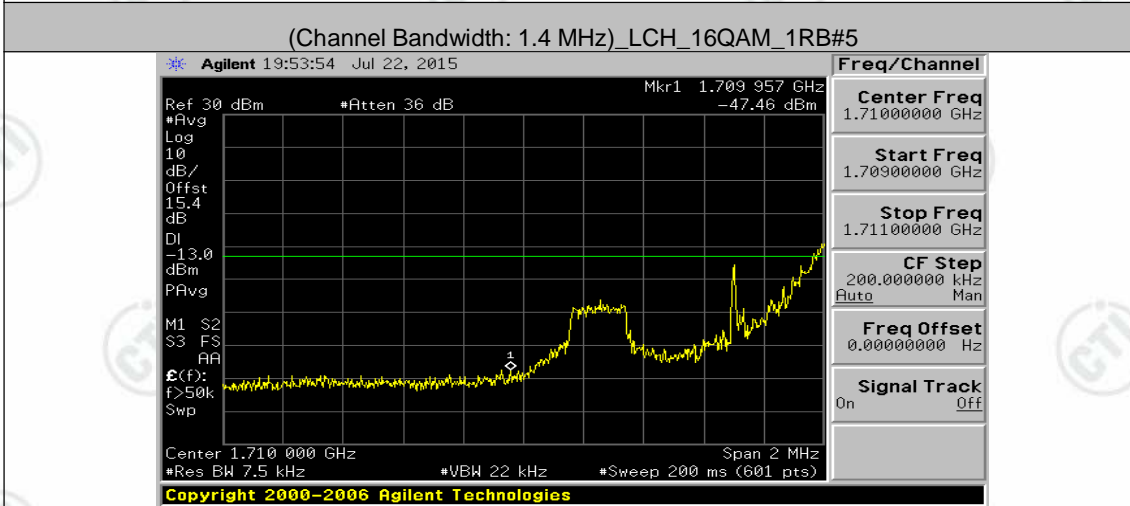
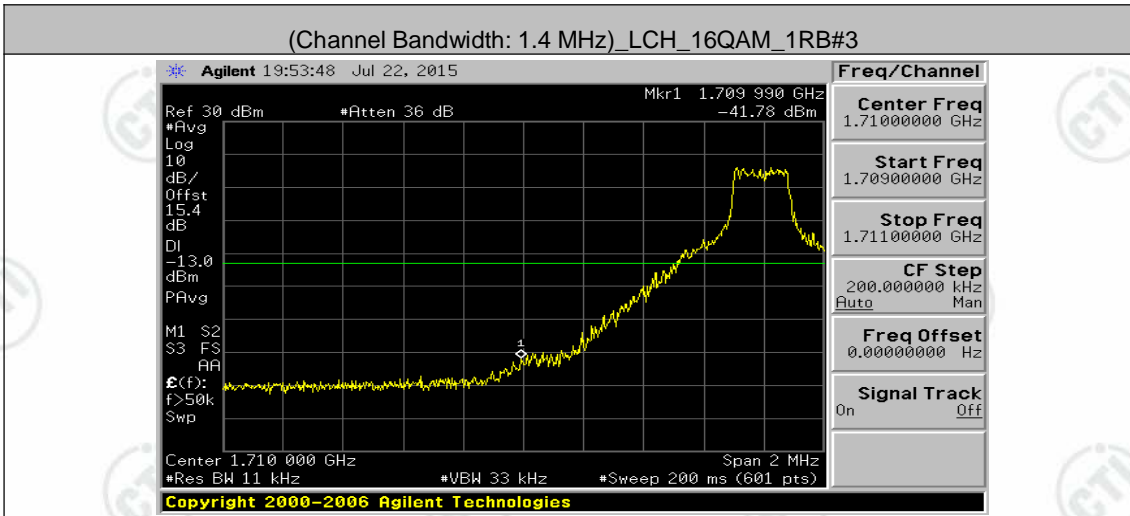

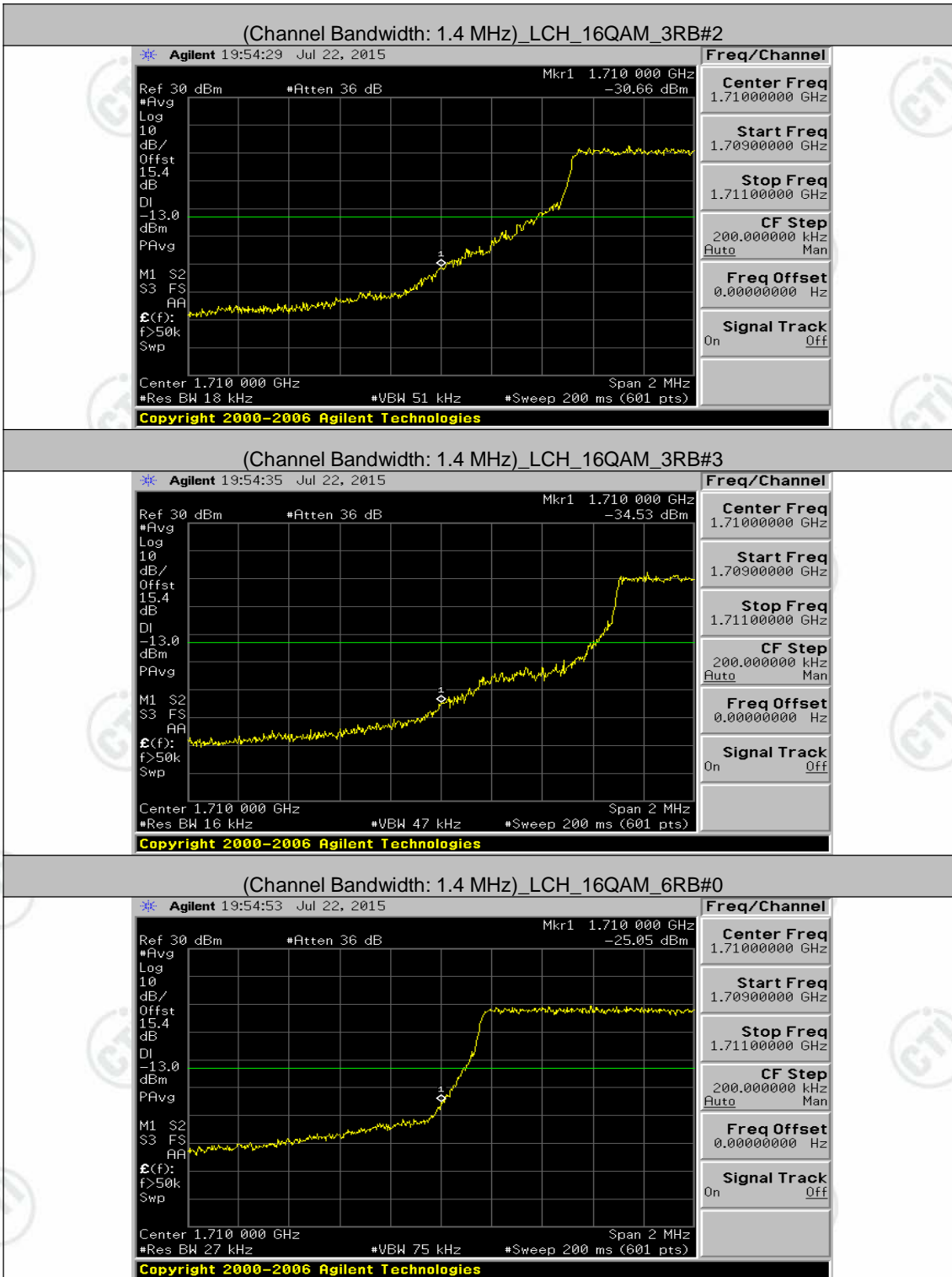

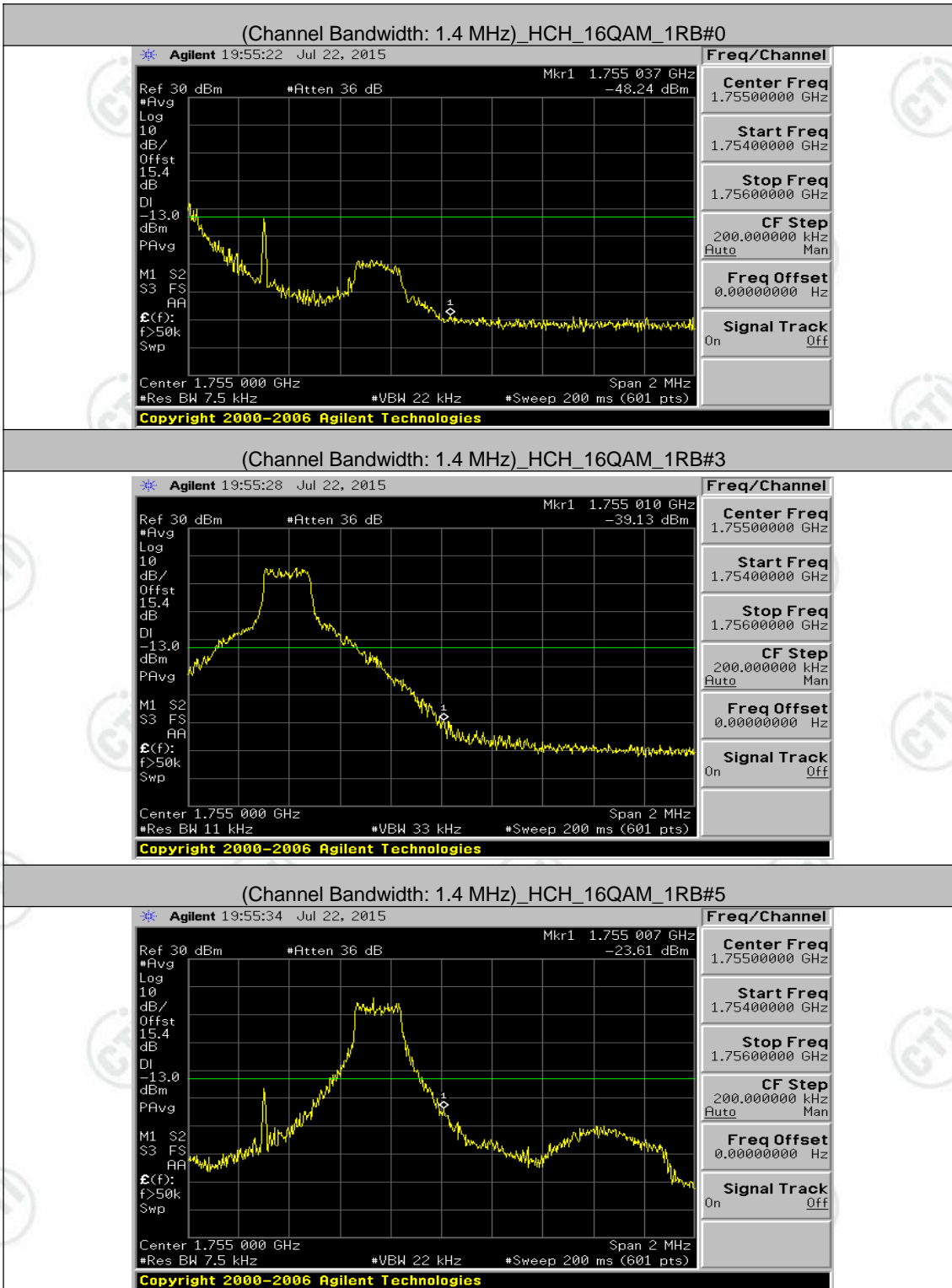

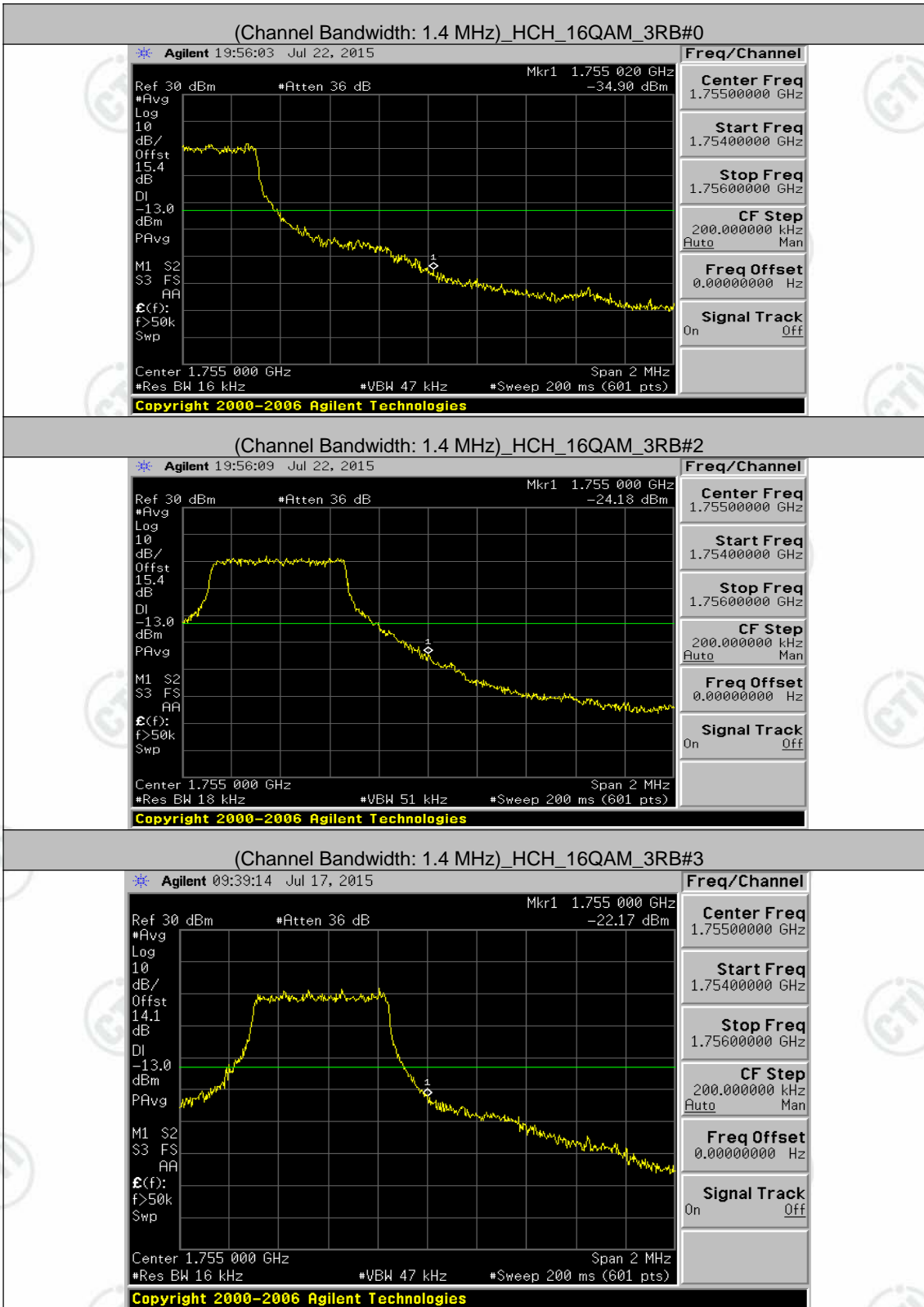

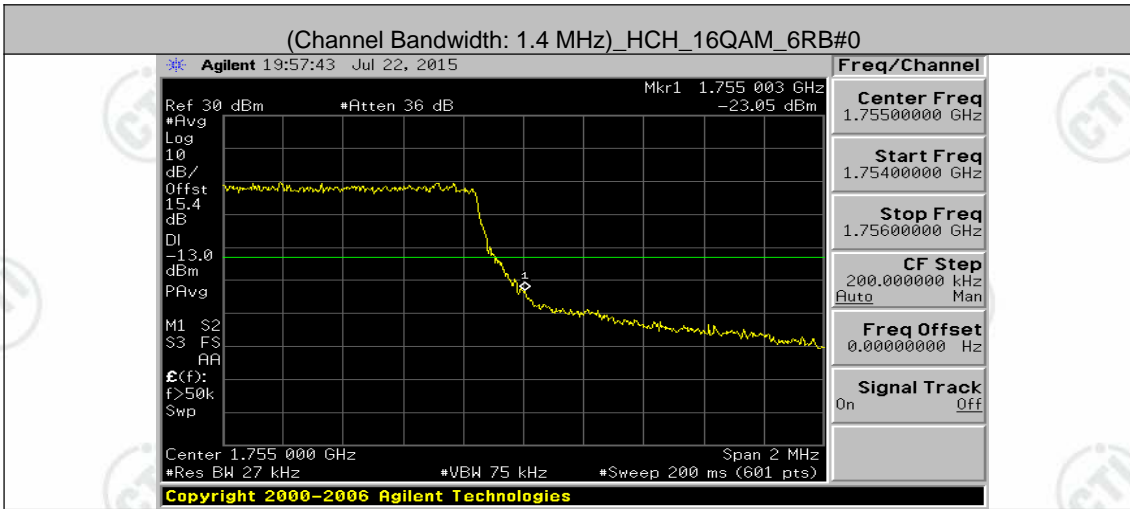

Channel Bandwidth: 3 MHz

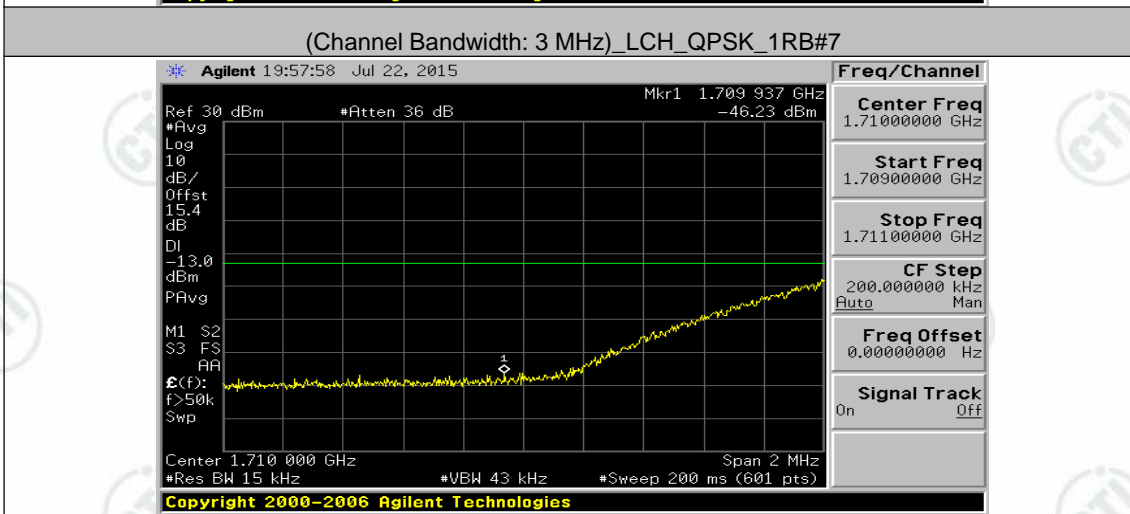
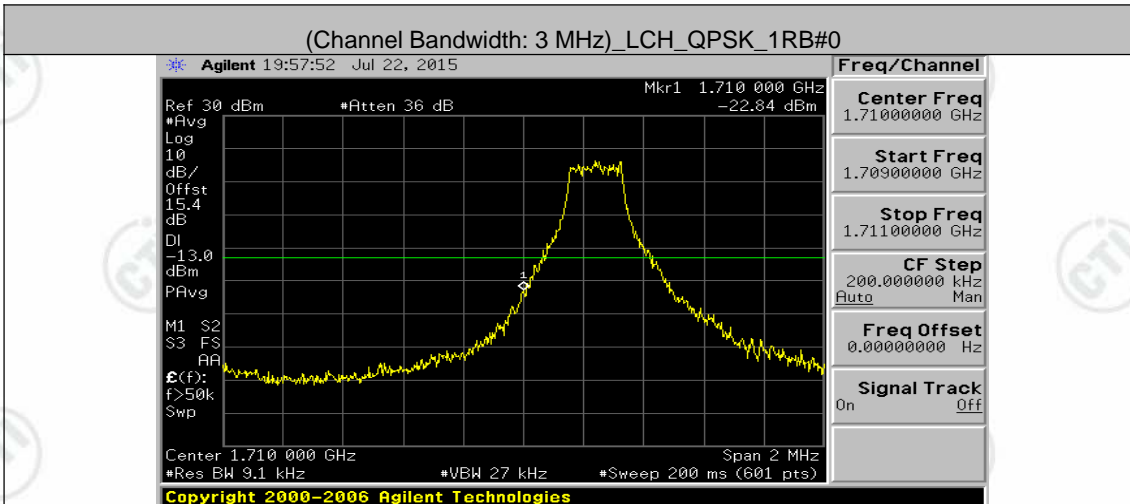

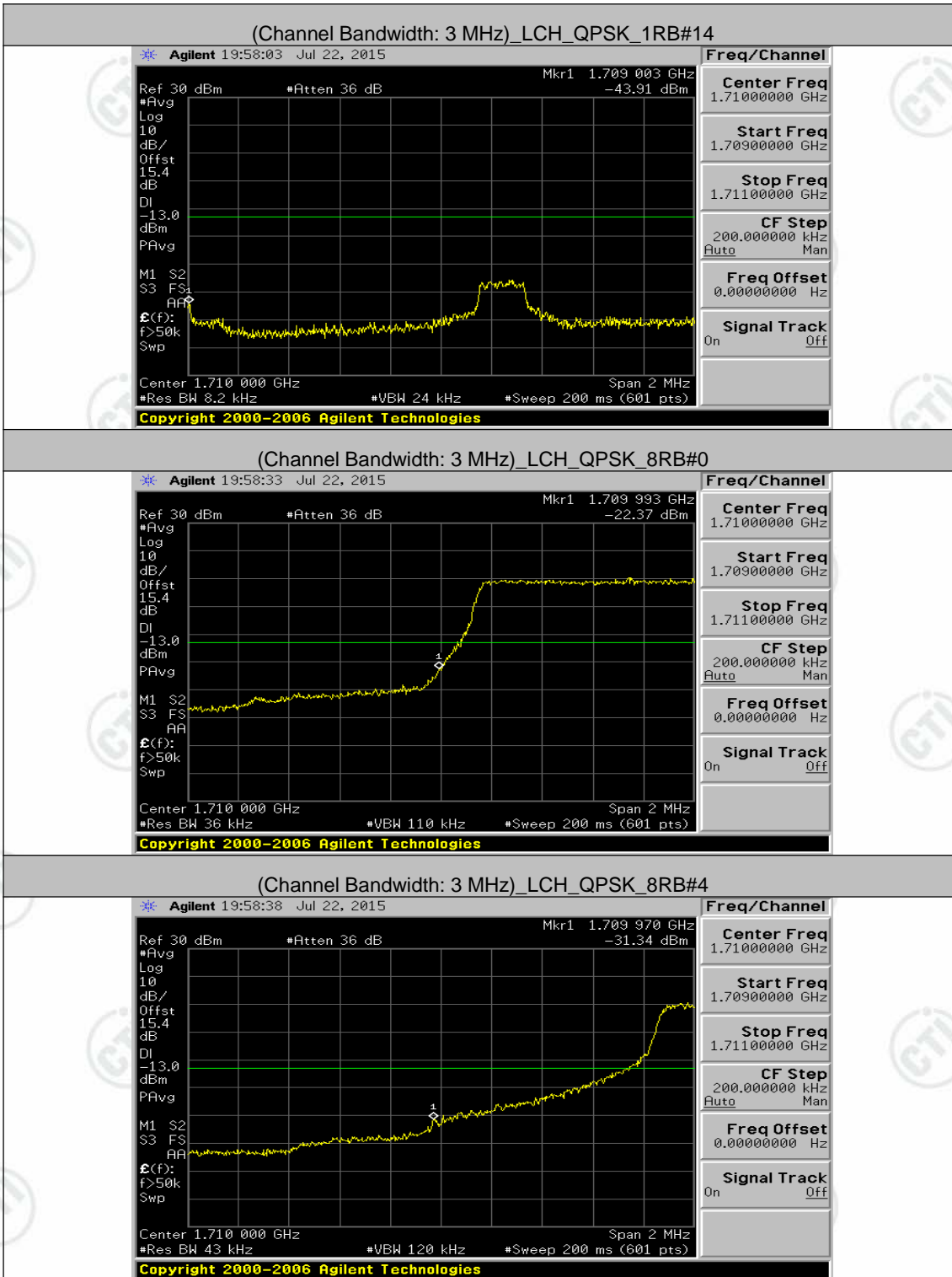

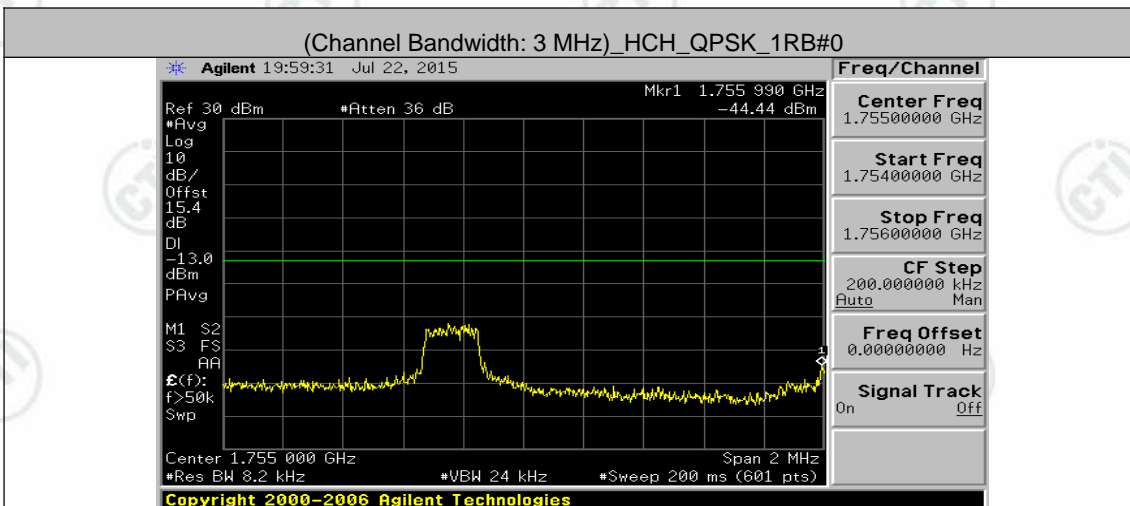
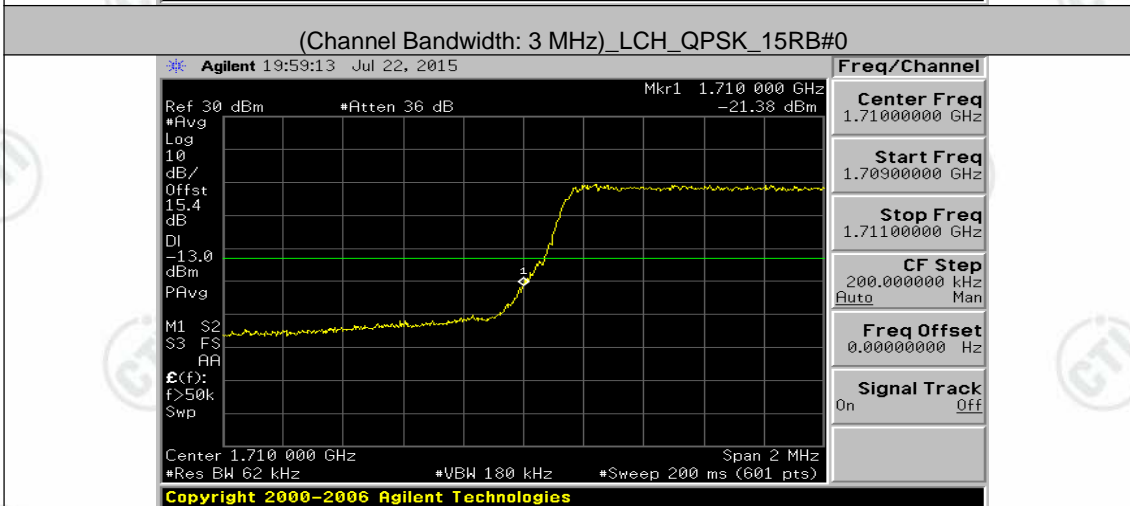
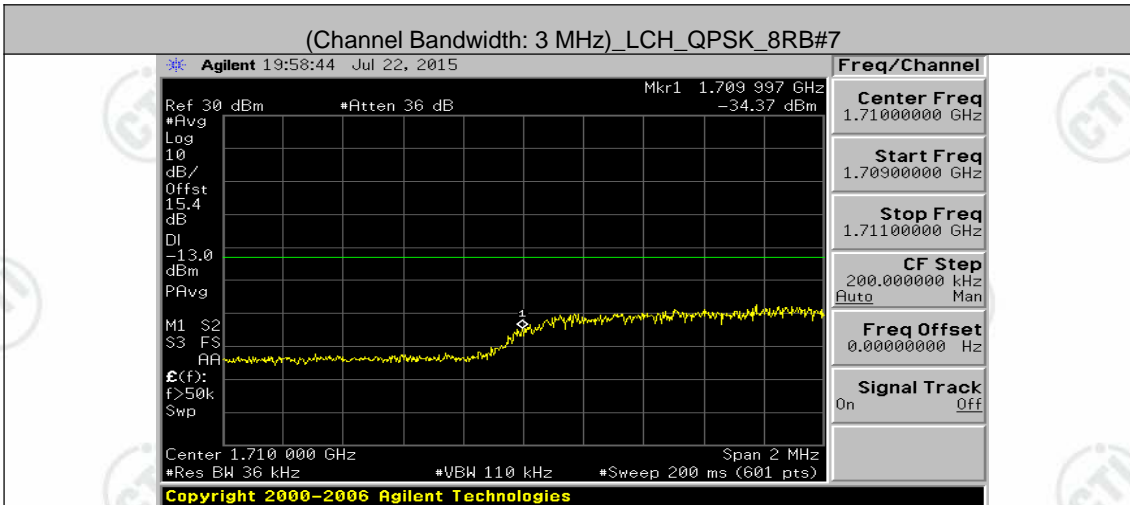

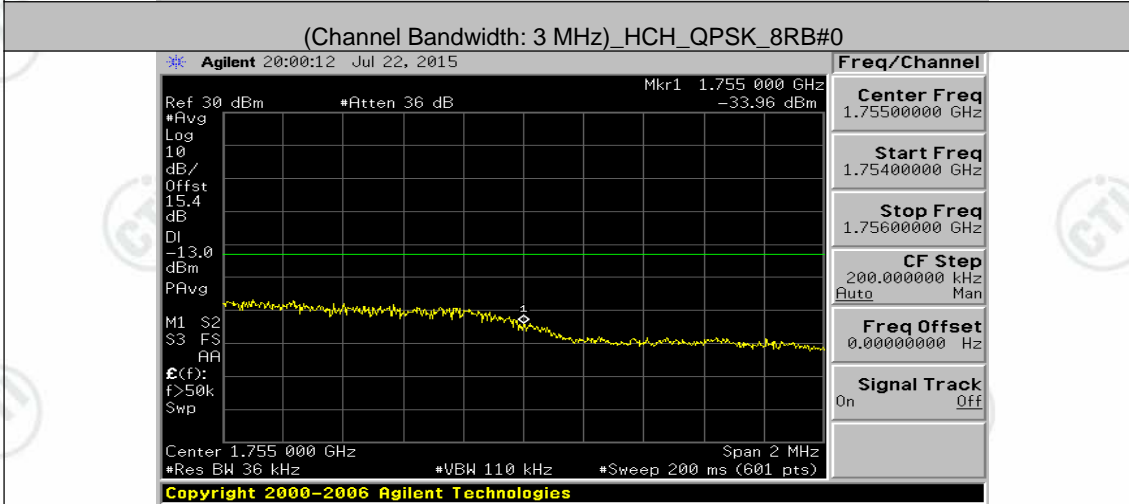
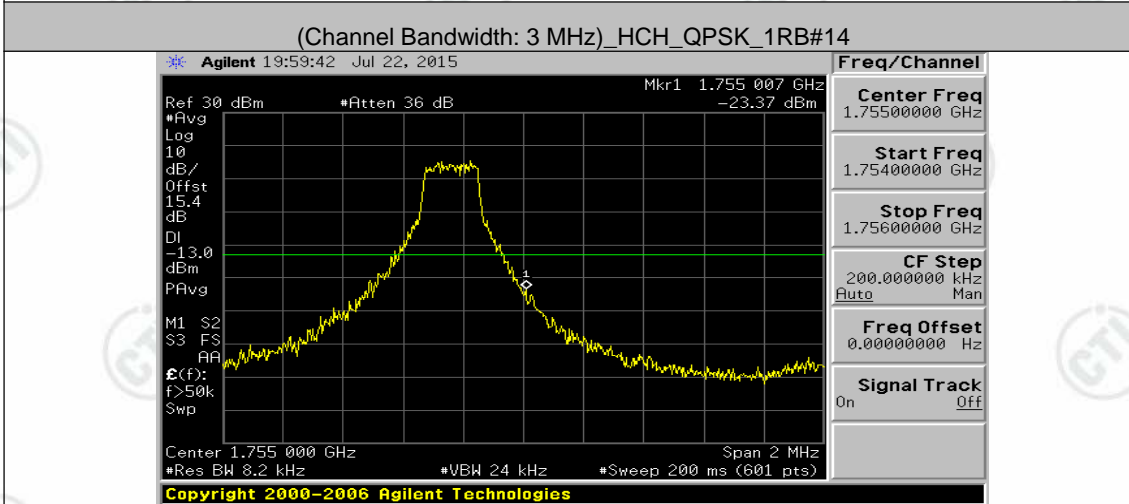
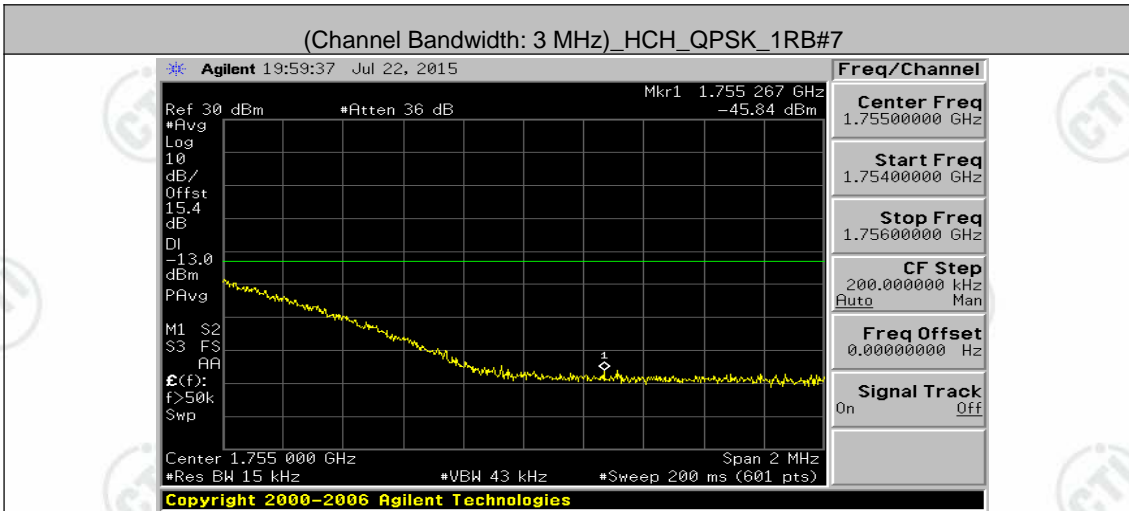

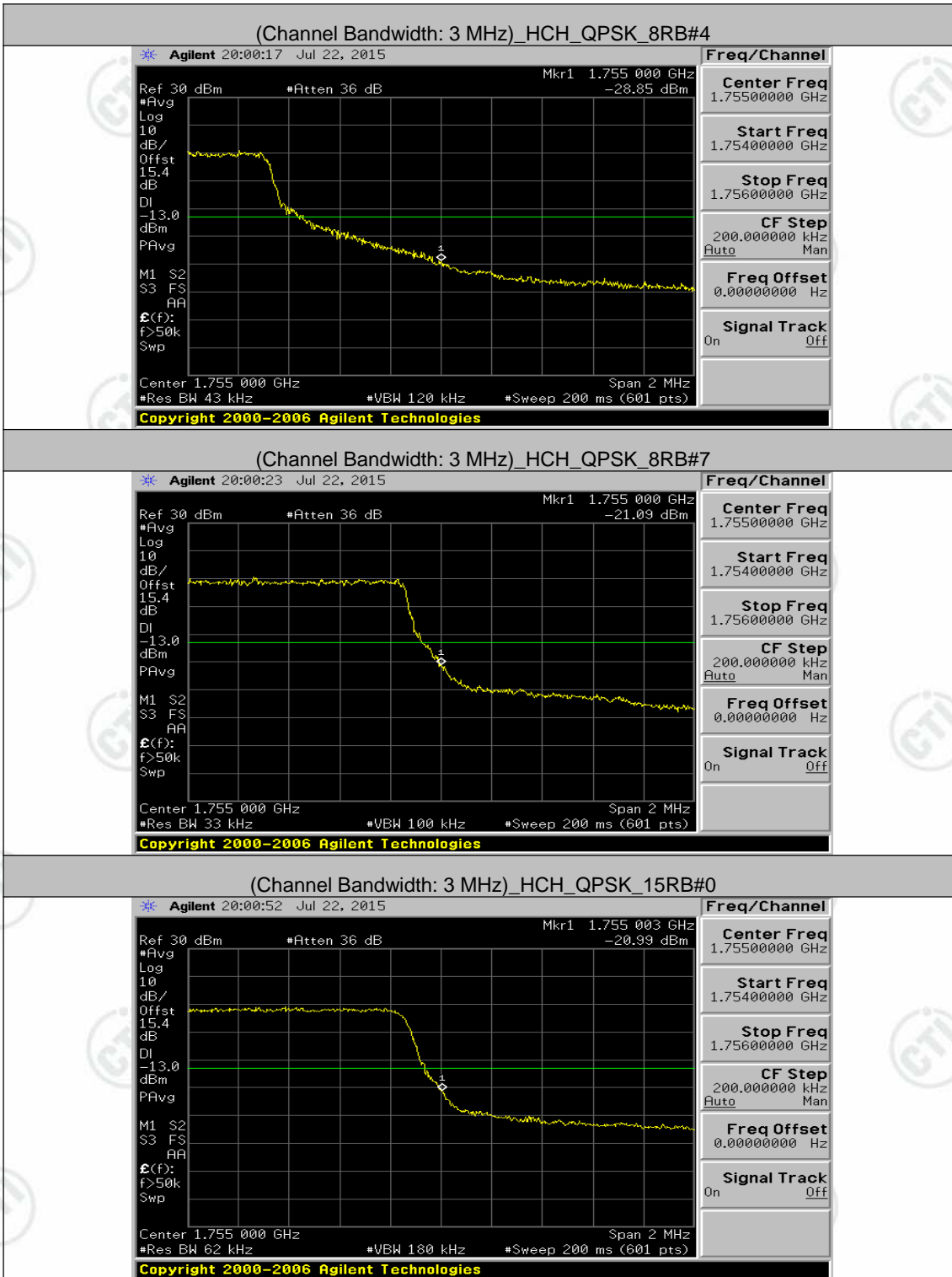

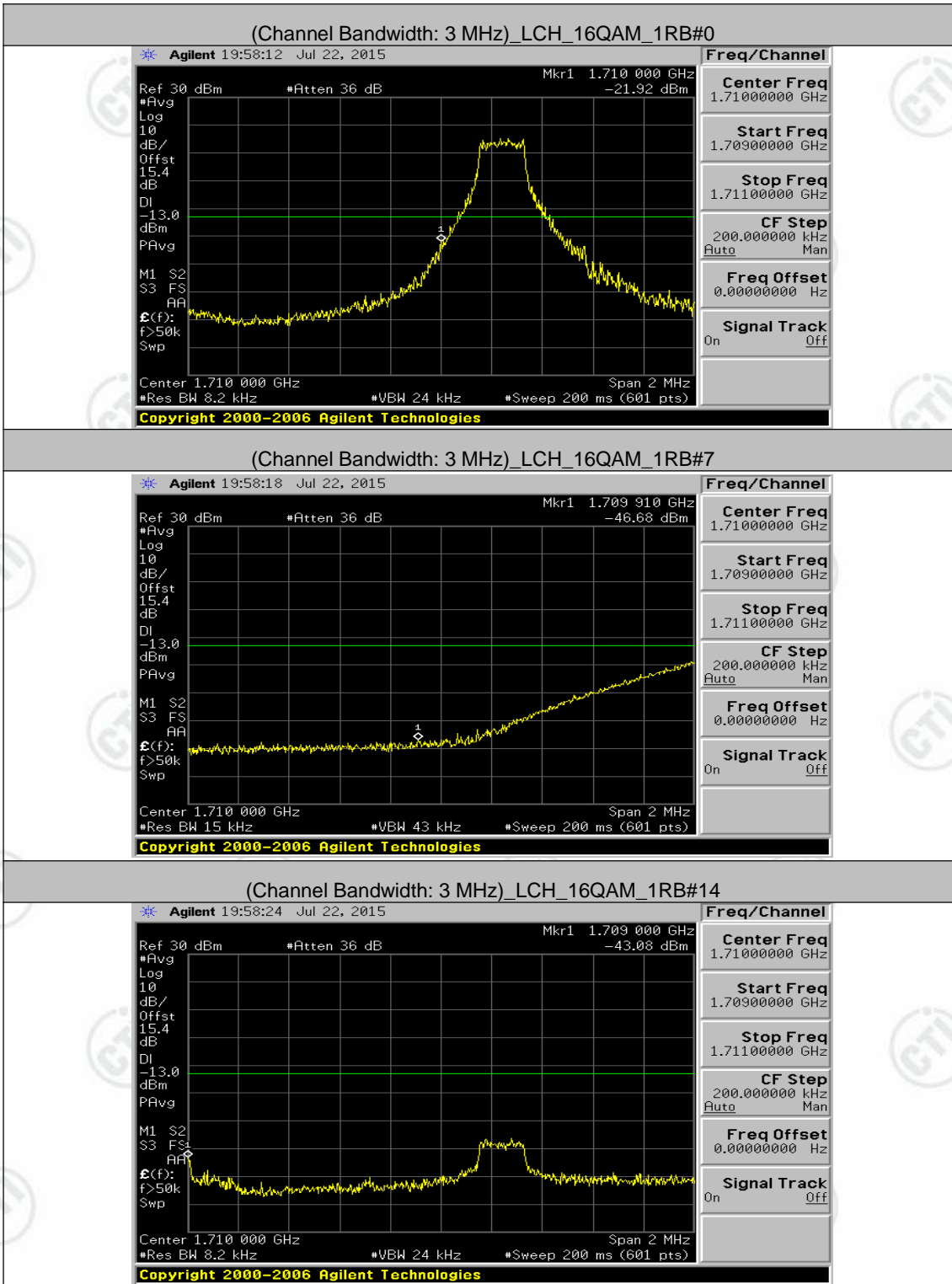

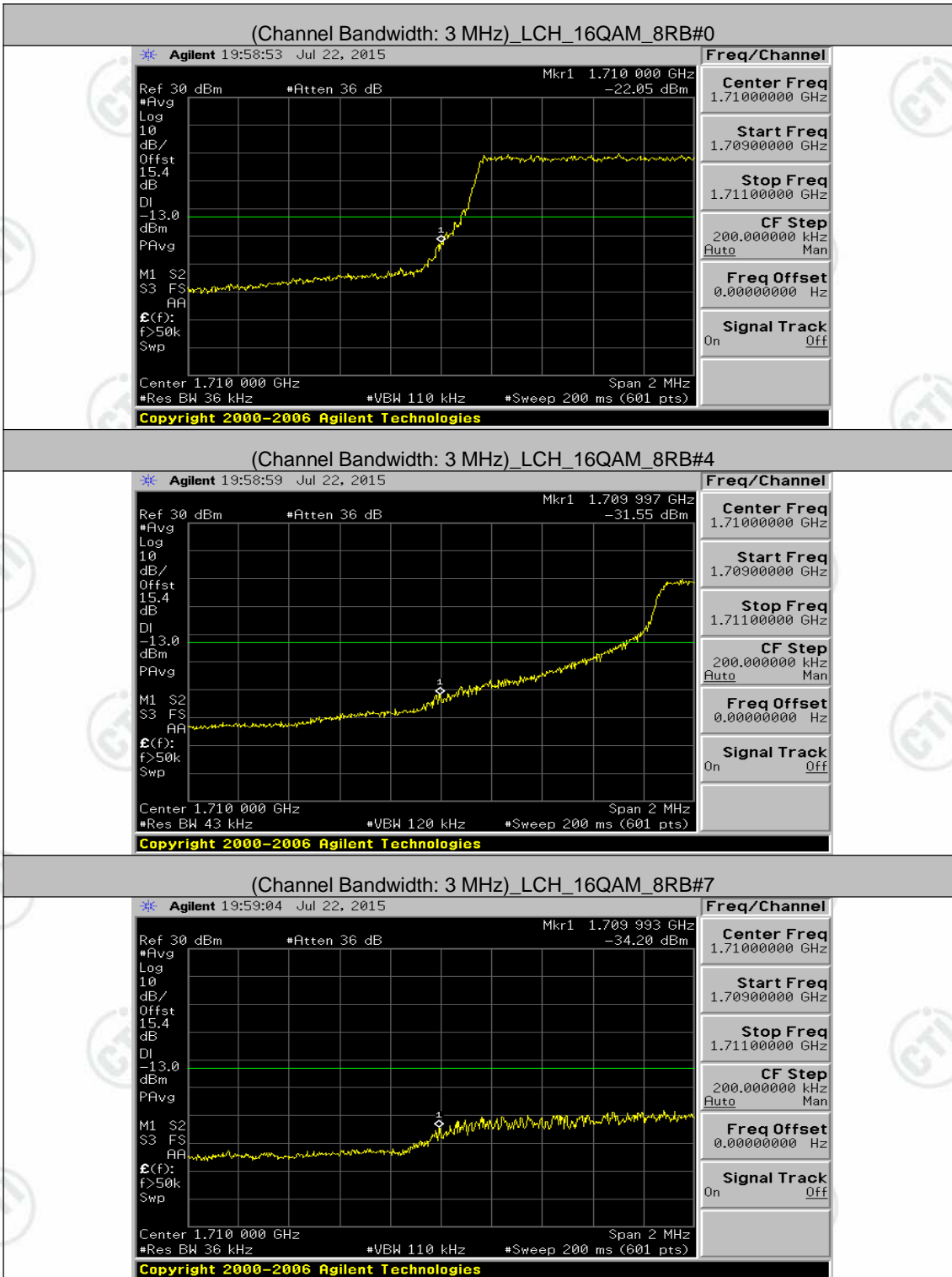

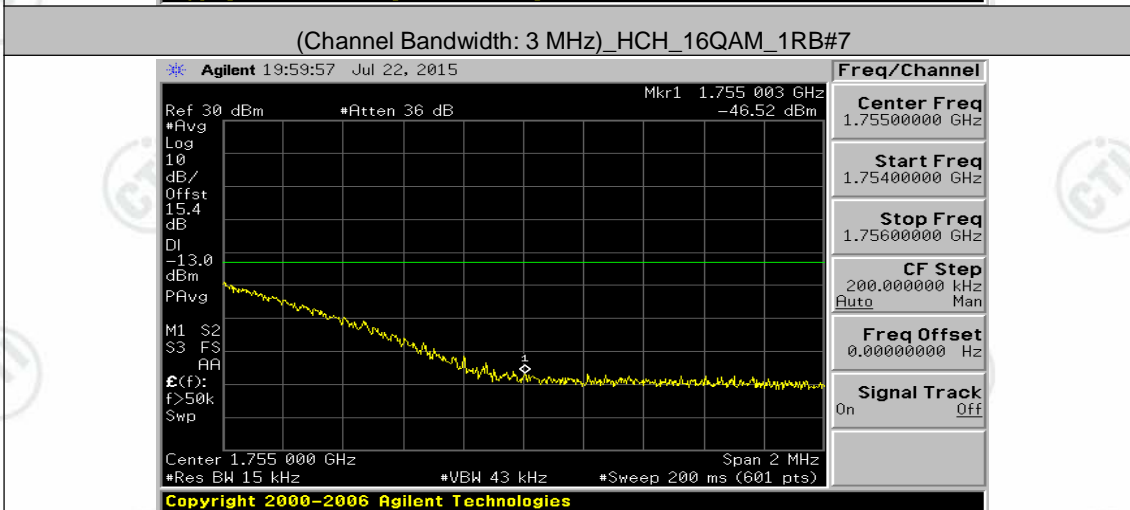
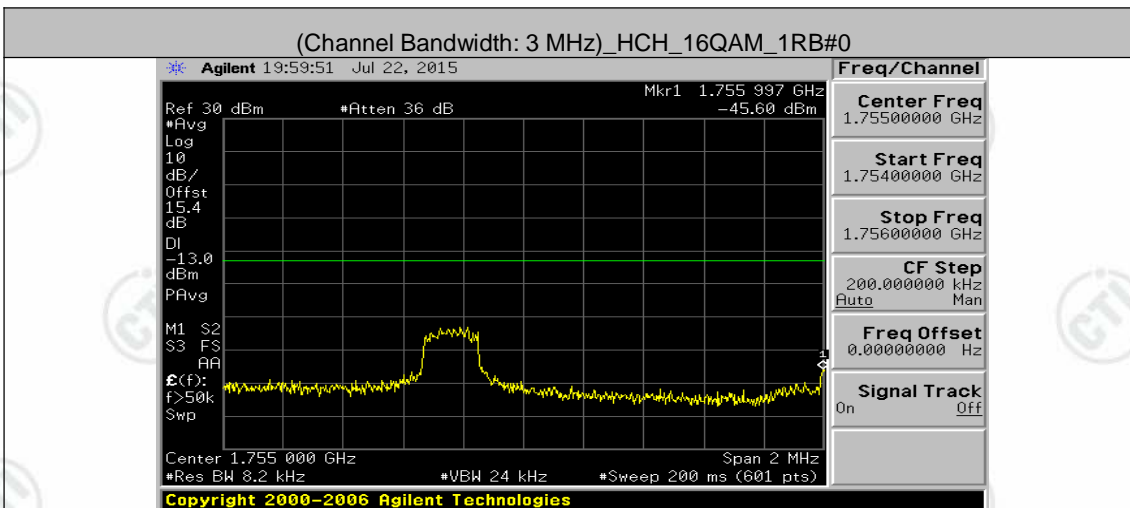
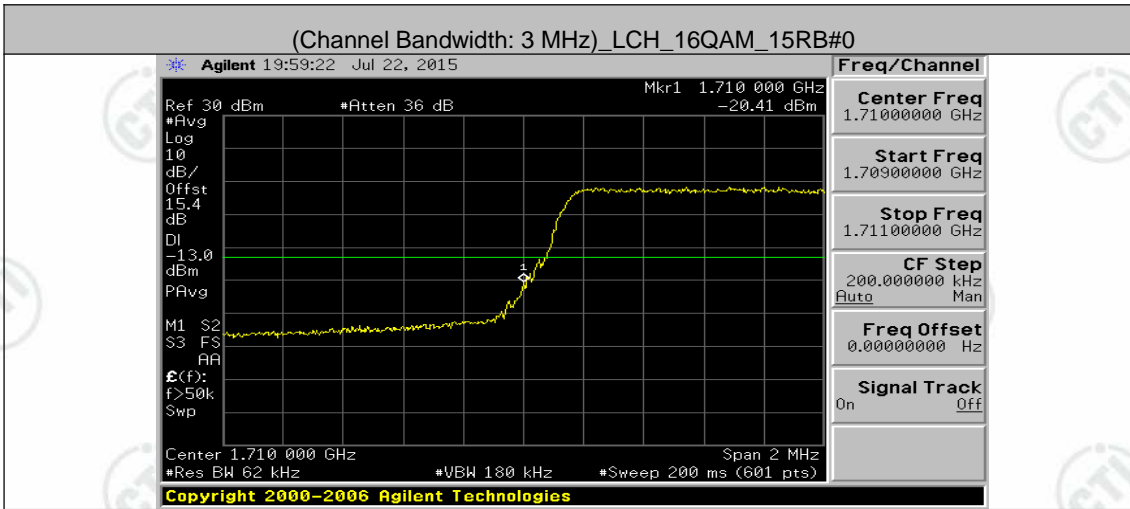

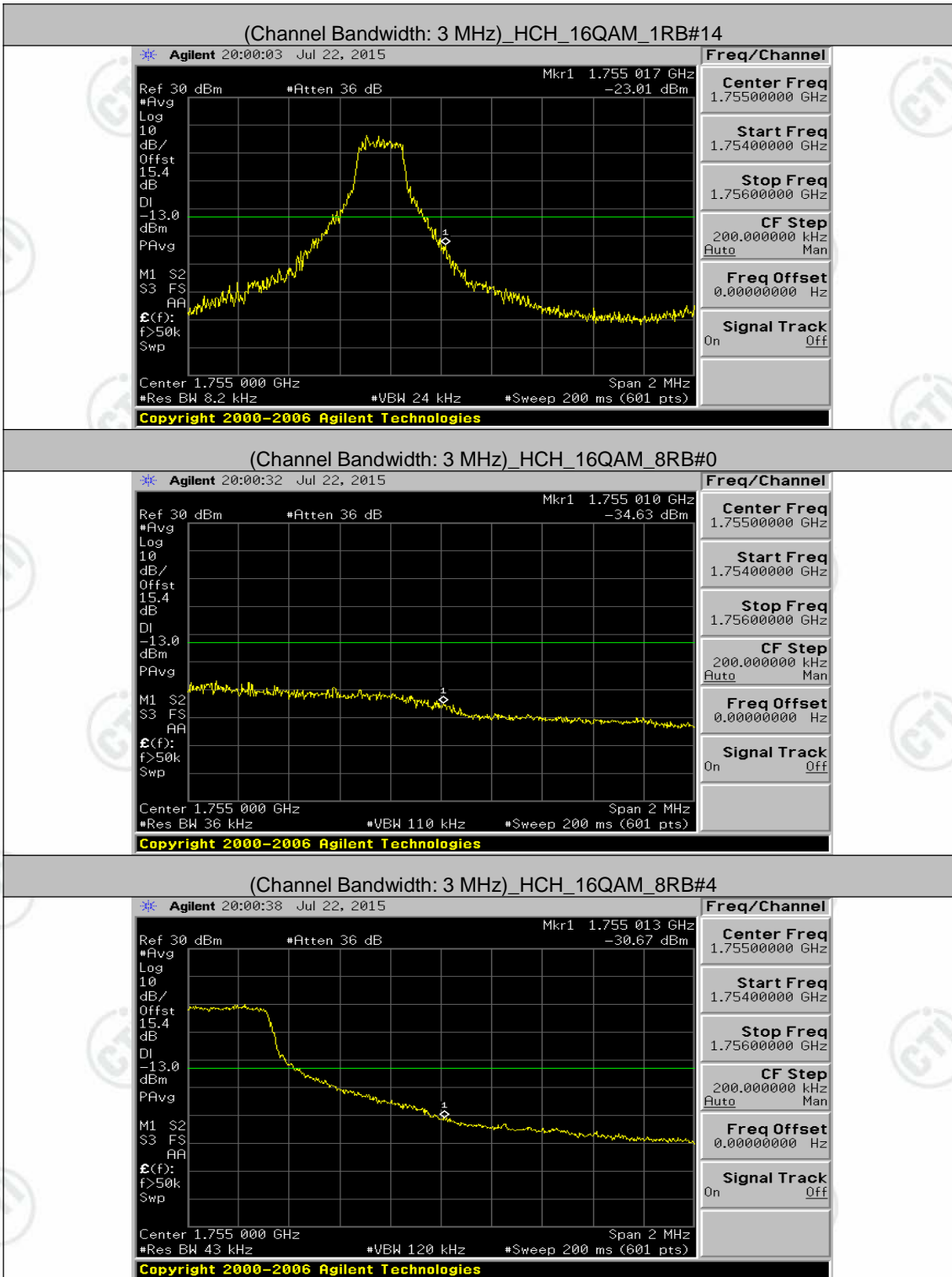

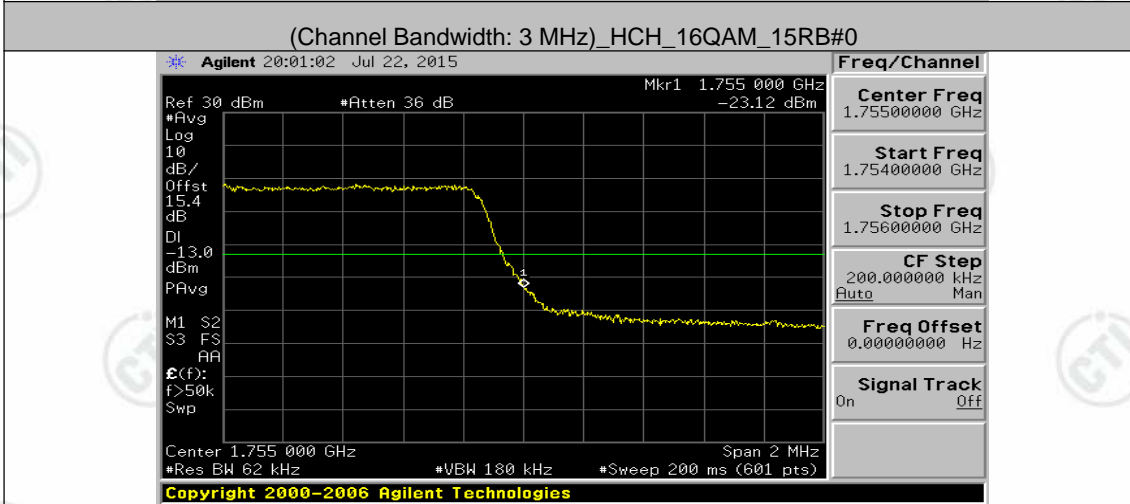
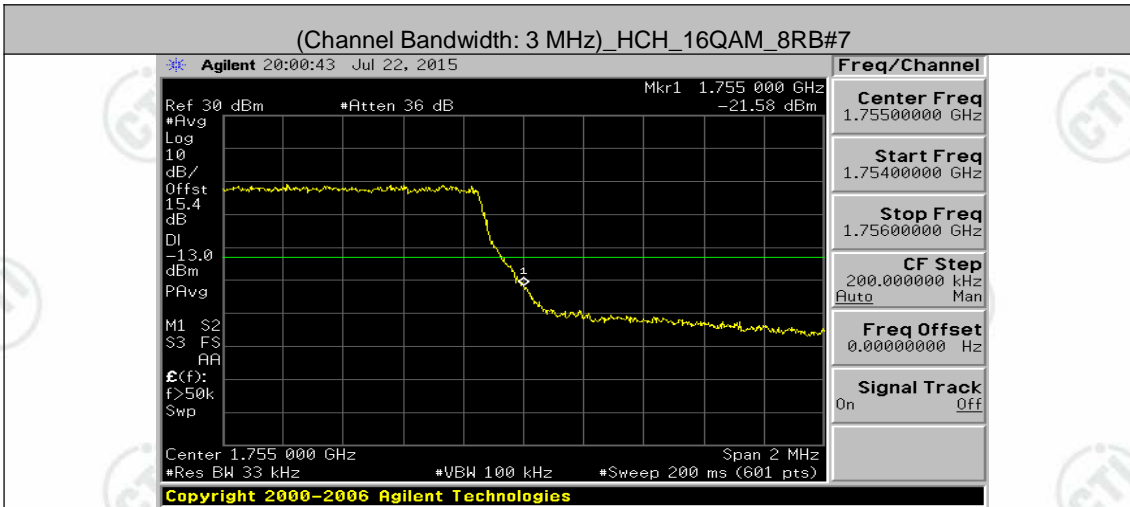

Channel Bandwidth: 5 MHz

