

APPLICATION CERTIFICATION FCC Part 15C

On Behalf of
Bewell Connect Corp.

Blood Pressure Monitor

Model No.: BW-BT1

FCC ID: 2AF8T-BW-BT1

Prepared for : Bewell Connect Corp
Address : 575 Boylston Street , Suite 3W, Boston, Massachusetts,
02116, UNITED STATES.

Prepared by : Shenzhen Accurate Technology Co., Ltd.
Address : 1/F., Building A, Changyuan New Material Port, Science & Industry
Park, Nanshan District, Shenzhen, Guangdong, P.R. China.

Tel: (0755) 26503290

Fax: (0755) 26503396

Report No. : ATE20181471
Date of Test : July 17, 2018-July 22, 2018
Date of Report : July 31, 2018

TABLE OF CONTENTS

Description	Page
Test Report Certification	
1. GENERAL INFORMATION	5
1.1. Description of Device (EUT).....	5
1.2. Carrier Frequency of Channels	6
1.3. Special Accessory and Auxiliary Equipment	7
1.4. Description of Test Facility	7
1.5. Measurement Uncertainty	7
2. MEASURING DEVICE AND TEST EQUIPMENT	8
3. OPERATION OF EUT DURING TESTING	9
3.1. Operating Mode	9
3.2. Configuration and peripherals	9
4. TEST PROCEDURES AND RESULTS	10
5. 6DB BANDWIDTH MEASUREMENT	11
5.1. Block Diagram of Test Setup.....	11
5.2. The Requirement For Section 15.247(a)(2).....	11
5.3. EUT Configuration on Measurement	11
5.4. Operating Condition of EUT	11
5.5. Test Procedure	11
5.6. Test Result	12
6. MAXIMUM PEAK OUTPUT POWER	14
6.1. Block Diagram of Test Setup.....	14
6.2. The Requirement For Section 15.247(b)(3).....	14
6.3. EUT Configuration on Measurement	14
6.4. Operating Condition of EUT	14
6.5. Test Procedure	14
6.6. Test Result	15
7. POWER SPECTRAL DENSITY MEASUREMENT	17
7.1. Block Diagram of Test Setup.....	17
7.2. The Requirement For Section 15.247(e).....	17
7.3. EUT Configuration on Measurement	17
7.4. Operating Condition of EUT	17
7.5. Test Procedure	18
7.6. Test Result	19
8. BAND EDGE COMPLIANCE TEST	21
8.1. Block Diagram of Test Setup.....	21
8.2. The Requirement For Section 15.247(d)	21
8.3. EUT Configuration on Measurement	21
8.4. Operating Condition of EUT	21
8.5. Test Procedure	22
8.6. Test Result	22
9. RADIATED SPURIOUS EMISSION TEST	28
9.1. Block Diagram of Test Setup.....	28

9.2.	The Limit For Section 15.247(d)	29
9.3.	Restricted bands of operation	30
9.4.	Configuration of EUT on Measurement	30
9.5.	Operating Condition of EUT	31
9.6.	Test Procedure	31
9.7.	The Field Strength of Radiation Emission Measurement Results	31
10.	CONDUCTED SPURIOUS EMISSION COMPLIANCE TEST	59
10.1.	Block Diagram of Test Setup.....	59
10.2.	The Requirement For Section 15.247(d)	59
10.3.	EUT Configuration on Measurement	59
10.4.	Operating Condition of EUT	59
10.5.	Test Procedure	60
10.6.	Test Result	60
11.	ANTENNA REQUIREMENT.....	62
11.1.	The Requirement	62
11.2.	Antenna Construction	62

Test Report Certification

Applicant : Bewell Connect Corp
Address : 575 Boylston Street , Suite 3W, Boston, Massachusetts,
02116, UNITED STATES.
Manufacturer : Shenzhen Kingyield Technology Co., Ltd.
Address : A5 Bldg, Fuzhong Industrial Zone, Xia Shi Wei road, Fuyong district, BaoAn,
ShenZhen, China.
Product : Blood Pressure Monitor
Model No. : BW-BT1
Trade name : Bewell Connect

Measurement Procedure Used:

FCC Rules and Regulations Part 15 Subpart C Section 15.247
ANSI C63.10: 2013

The EUT was tested according to DTS test procedure of Apr 05, 2017 KDB558074 D01 DTS Meas Guidance v04 for compliance to FCC 47CFR 15.247 requirements.

The device described above is tested by SHENZHEN ACCURATE TECHNOLOGY CO. LTD to determine the maximum emission levels emanating from the device. The maximum emission levels are compared to the FCC Part 15 Subpart C Section 15.247. The measurement results are contained in this test report and SHENZHEN ACCURATE TECHNOLOGY CO. LTD is assumed full responsibility for the accuracy and completeness of these measurements. Also, this report shows that the Equipment Under Test (EUT) is to be technically compliant with the FCC requirements.

This report applies to above tested sample only. This report shall not be reproduced in part without written approval of SHENZHEN ACCURATE TECHNOLOGY CO. LTD.

Date of Test : July 17, 2018-July 22, 2018

Date of Report: July 31, 2018

Prepared by :

(Tim Zhang, Engineer)

Approved & Authorized Signer :

(Sean Liu, Manager)

Shenzhen Accurate Technology Co., Ltd.

Address: 1/F., Building A, Changyuan New Material Port, Science & Industry Park, Nanshan District, Shenzhen, Guangdong, P.R. China

Tel: +86-755-26503290

Fax: +86-755-26503396

E-mail: webmaster@atc-lab.com

Http://www.atc-lab.com

1. GENERAL INFORMATION

1.1. Description of Device (EUT)

EUT	:	Blood Pressure Monitor
Model Number	:	BW-BT1
Trade Name	:	Bewell Connect
Bluetooth version	:	BT V4.0 LE
Frequency Range	:	2402MHz-2480MHz
Number of Channels	:	40
Antenna Gain	:	0dBi
Antenna type	:	Integral Antenna
Power Supply	:	DC 6V via Battery
Modulation mode	:	GFSK
Applicant	:	Bewell Connect Corp
Address	:	575 Boylston Street , Suite 3W, Boston, Massachusetts, 02116, UNITED STATES
Manufacturer	:	Shenzhen Kingyield Technology Co., Ltd.
Address	:	A5 Bldg, Fuzhong Industrial Zone, Xia Shi Wei road, Fuyong district, BaoAn, ShenZhen, China.
Date of sample received	:	July 16, 2018
Date of Test	:	July 17, 2018-July 22, 2018

1.2. Carrier Frequency of Channels

Channel	Frequency (MHz)	Channel	Frequency (MHz)	Channel	Frequency (MHz)	Channel	Frequency (MHz)
0	2402	10	2422	20	2442	30	2462
1	2404	11	2424	21	2444	31	2464
2	2406	12	2426	22	2446	32	2466
3	2408	13	2428	23	2448	33	2468
4	2410	14	2430	24	2450	34	2470
5	2412	15	2432	25	2452	35	2472
6	2414	16	2434	26	2454	36	2474
7	2416	17	2436	27	2456	37	2476
8	2418	18	2438	28	2458	38	2478
9	2420	19	2440	29	2460	39	2480

2. MEASURING DEVICE AND TEST EQUIPMENT

Table 1: List of Test and Measurement Equipment

Kind of equipment	Manufacturer	Type	S/N	Calibrated dates	Calibrated until
EMI Test Receiver	Rohde&Schwarz	ESCS30	100307	Jan. 06, 2018	Jan. 05, 2019
EMI Test Receiver	Rohde&Schwarz	ESPI3	101526/003	Jan. 06, 2018	Jan. 05, 2019
Spectrum Analyzer	Rohde&Schwarz	FSV-40	101495	Jan. 06, 2018	Jan. 05, 2019
Spectrum Analyzer	Agilent	E7405A	MY45115511	Jan. 06, 2018	Jan. 05, 2019
Pre-Amplifier	Rohde&Schwarz	CBLU118354 0-01	3791	Jan. 06, 2018	Jan. 05, 2019
Loop Antenna	Schwarzbeck	FMZB1516	1516131	Jan. 06, 2018	Jan. 05, 2019
Bilog Antenna	Schwarzbeck	VULB9163	9163-323	Jan. 06, 2018	Jan. 05, 2019
Horn Antenna	Schwarzbeck	BBHA9120D	9120D-655	Jan. 06, 2018	Jan. 05, 2019
Horn Antenna	Schwarzbeck	BBHA9170	9170-359	Jan. 06, 2018	Jan. 05, 2019
Open Switch and Control Unit	Rohde&Schwarz	OSP120 + OSP-B157	101244 + 100866	Jan. 06, 2018	Jan. 05, 2019
LISN	Rohde&Schwarz	ESH3-Z5	100305	Jan. 06, 2018	Jan. 05, 2019
LISN	Schwarzbeck	NSLK8126	8126431	Jan. 06, 2018	Jan. 05, 2019
Highpass Filter	Wainwright Instruments	WHKX3.6/18 G-10SS	N/A	Jan. 06, 2018	Jan. 05, 2019
Band Reject Filter	Wainwright Instruments	WRCG2400/2 485-2375/2510 -60/11SS	N/A	Jan. 06, 2018	Jan. 05, 2019

3. OPERATION OF EUT DURING TESTING

3.1. Operating Mode

The mode is used: **BLE Transmitting mode**

Low Channel: 2402MHz

Middle Channel: 2440MHz

High Channel: 2480MHz

3.2. Configuration and peripherals

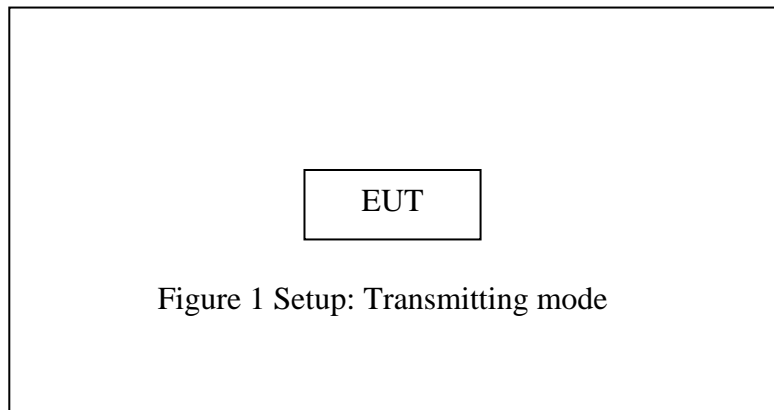

4. TEST PROCEDURES AND RESULTS

FCC&IC Rules	Description of Test	Result
Section 15.247(a)(2)	6dB Bandwidth Test	Compliant
Section 15.247(e)	Power Spectral Density Test	Compliant
Section 15.247(b)(3)	Maximum Peak Output Power Test	Compliant
Section 15.247(d)	Band Edge Compliance Test	Compliant
Section 15.247(d) Section 15.209	Radiated Spurious Emission Test	Compliant
Section 15.247(d)	Conducted Spurious Emission Test	Compliant
Section 15.207	AC Power Line Conducted Emission Test	N/A
Section 15.203	Antenna Requirement	Compliant

Note: The power supply mode of the EUT is DC 6V, According to the FCC standard requirements, conducted emission is not applicable.

5. 6DB BANDWIDTH MEASUREMENT

5.1. Block Diagram of Test Setup



(EUT: Blood Pressure Monitor)

5.2. The Requirement For Section 15.247(a)(2)

Section 15.247(a)(2): Systems using digital modulation techniques may operate in the 902-928MHz, 2400-2483.5MHz, and 5725-5850MHz bands. The minimum 6 dB bandwidth shall be at least 500 kHz.

5.3. EUT Configuration on Measurement

The equipment is installed on the emission measurement to meet the commission requirements and operating regulations in a manner which tends to maximize its emission characteristics in normal application.

5.4. Operating Condition of EUT

5.4.1. Setup the EUT and simulator as shown as Section 5.1.

5.4.2. Turn on the power of all equipment.

5.4.3. Let the EUT work in TX modes measure it. The transmit frequency are 2402-2480MHz. We select 2402MHz, 2440MHz, and 2480MHz TX frequency to transmit.

5.5. Test Procedure

5.5.1. The transmitter output was connected to the spectrum analyzer through a low loss cable.

5.5.2. Set RBW of spectrum analyzer to 100 kHz and VBW to 300 kHz.

5.5.3. The 6dB bandwidth is defined as the total spectrum the power of which is higher than peak power minus 6dB.

5.6. Test Result

Channel	Frequency (MHz)	6 dB Bandwidth (MHz)	Minimum Limit(MHz)	PASS/FAIL
0	2402	0.712	0.5	PASS
19	2440	0.725	0.5	PASS
39	2480	0.712	0.5	PASS

The spectrum analyzer plots are attached as below.

channel 0

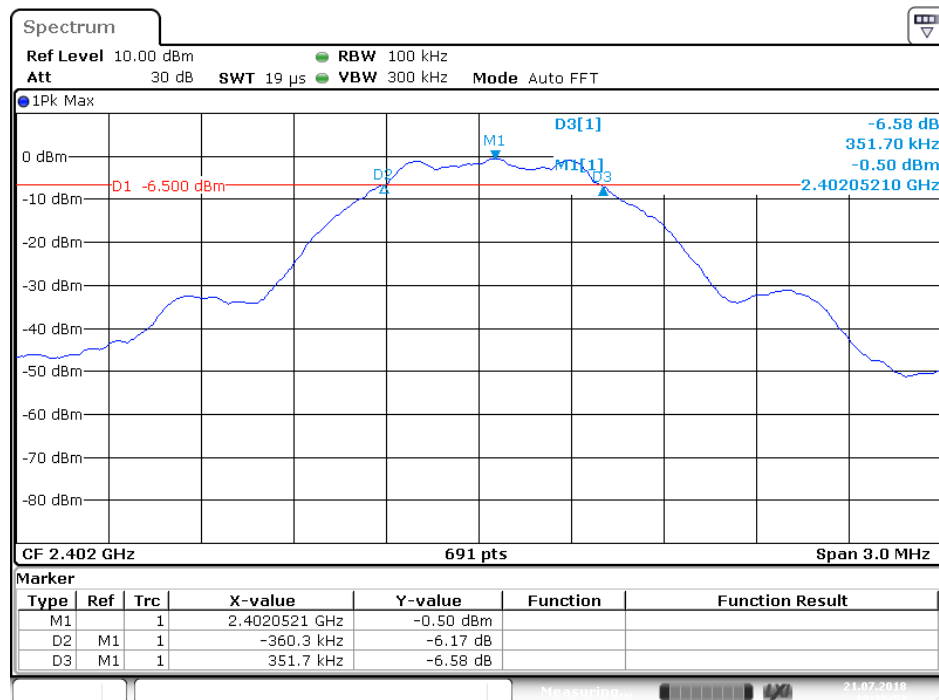

Date: 21.JUL.2018 10:25:52

channel 19

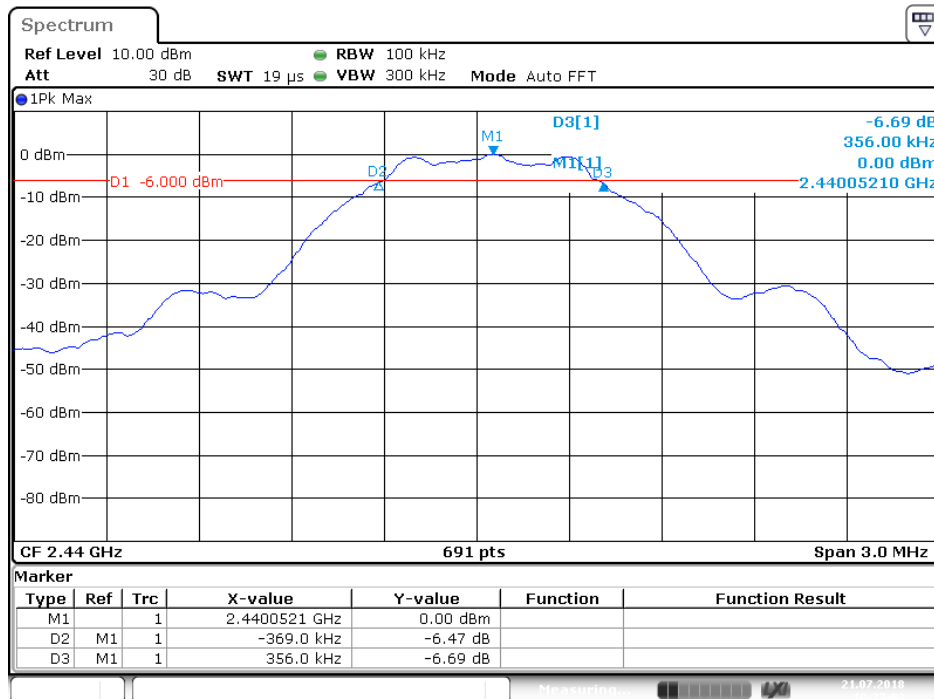

Date: 21.JUL.2018 10:27:03

channel 39

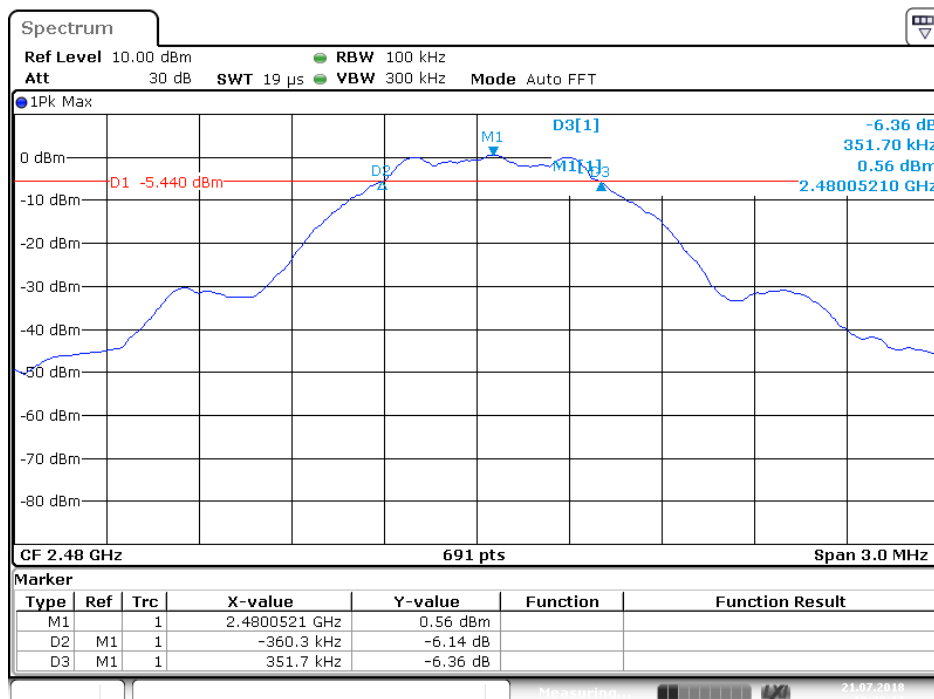

Date: 21.JUL.2018 10:28:17

Shenzhen Accurate Technology Co., Ltd.

Address: 1/F., Building A, Changyuan New Material Port, Science & Industry Park, Nanshan District, Shenzhen, Guangdong, P.R. China

Tel: +86-755-26503290

Fax: +86-755-26503396

E-mail: webmaster@atc-lab.com

Http://www.atc-lab.com

6. MAXIMUM PEAK OUTPUT POWER

6.1. Block Diagram of Test Setup



(EUT: Blood Pressure Monitor)

6.2. The Requirement For Section 15.247(b)(3)

Section 15.247(b)(3): For systems using digital modulation in the 902-928MHz, 2400-2483.5MHz, and 5725-5850MHz bands: 1 Watt.

6.3. EUT Configuration on Measurement

The equipment are installed on the emission Measurement to meet the commission requirements and operating regulations in a manner which tends to maximize its emission characteristics in normal application.

6.4. Operating Condition of EUT

6.4.1. Setup the EUT and simulator as shown as Section 6.1.

6.4.2. Turn on the power of all equipment.

6.4.3. Let the EUT work in TX modes measure it. The transmit frequency are 2402-2480MHz. We select 2402MHz, 2440MHz, and 2480MHz TX frequency to transmit.

6.5. Test Procedure

6.5.1. The transmitter output was connected to the spectrum analyzer through a low loss cable.

6.5.2. Set RBW of spectrum analyzer to 1 MHz and VBW to 3MHz.

6.5.3. Measurement the maximum peak output power.

6.6. Test Result

Channel	Frequency (MHz)	Peak Power Output (dBm)	Antenna gain (dBi)	E.I.P.R. (dBm)	Peak Power Limit (dBm)	Pass / Fail
0	2402	-5.37	0	-5.37	30	PASS
19	2440	-4.88	0	-4.88	30	PASS
39	2480	-4.35	0	-4.35	30	PASS

The spectrum analyzer plots are attached as below.

channel 0

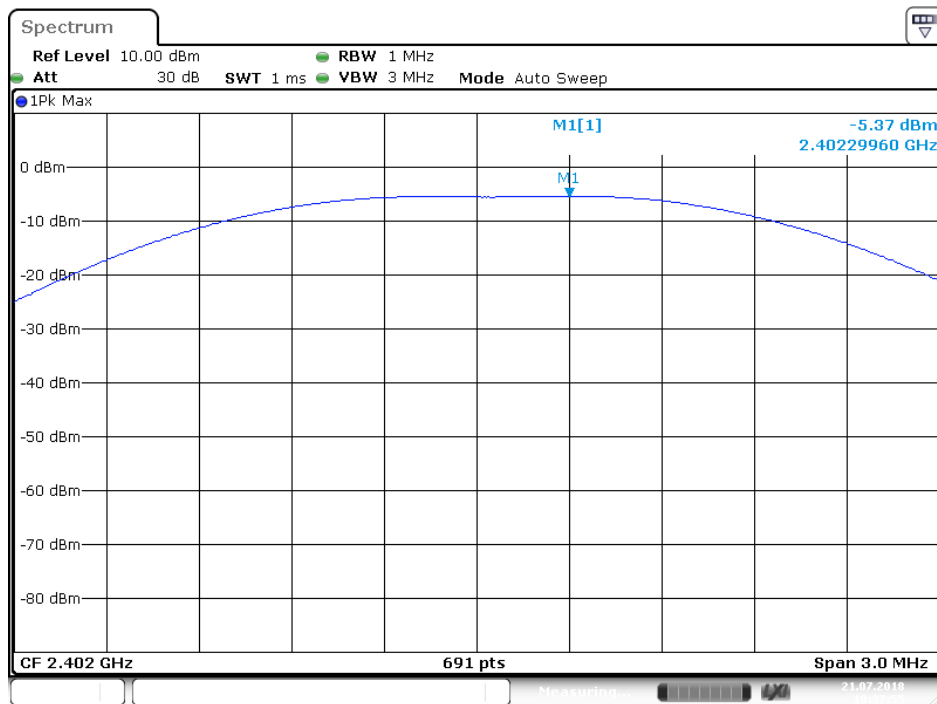

Date: 21.JUL.2018 10:37:55

channel 19

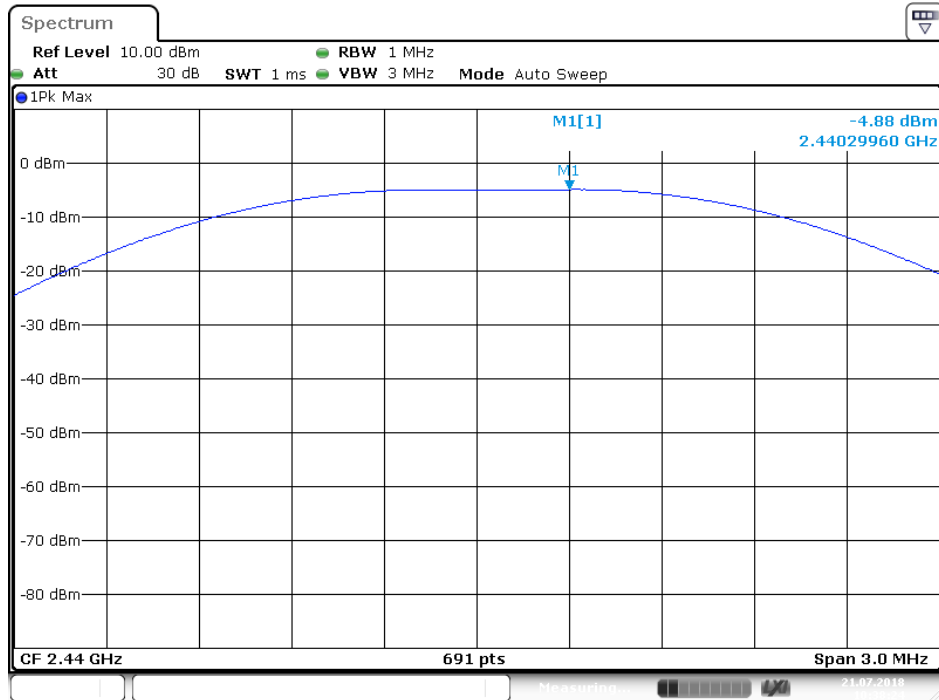

Date: 21.JUL.2018 10:38:24

channel 39

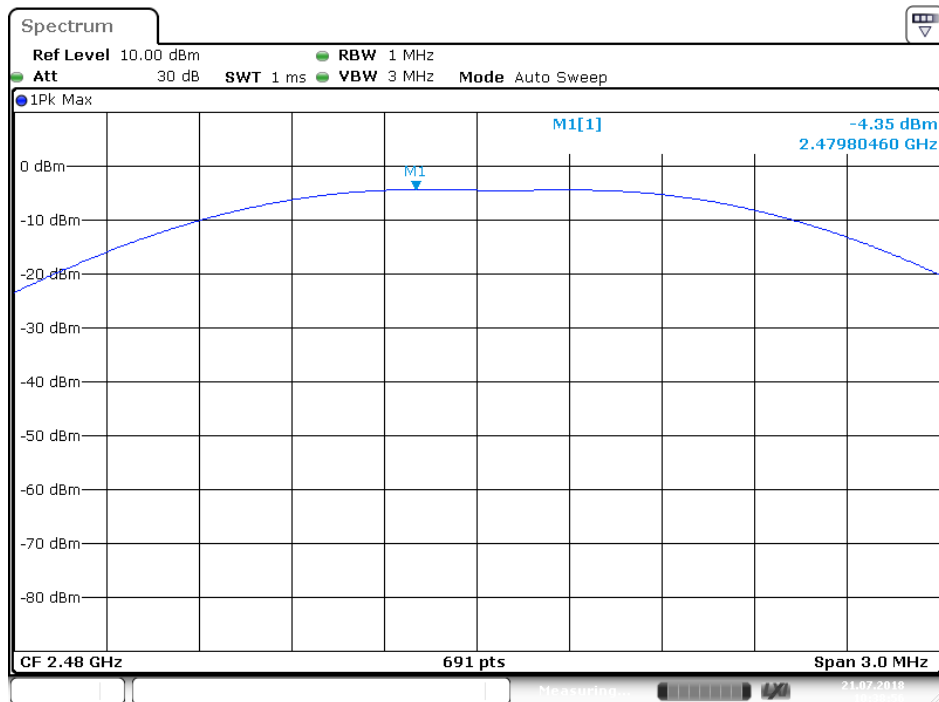

Date: 21.JUL.2018 10:38:56

Shenzhen Accurate Technology Co., Ltd.

Address: 1/F., Building A, Changyuan New Material Port, Science & Industry Park, Nanshan District, Shenzhen, Guangdong, P.R. China

Tel: +86-755-26503290

Fax: +86-755-26503396

E-mail: webmaster@atc-lab.com

Http://www.atc-lab.com

7. POWER SPECTRAL DENSITY MEASUREMENT

7.1. Block Diagram of Test Setup



(EUT: Blood Pressure Monitor)

7.2. The Requirement For Section 15.247(e)

Section 15.247(e): For digitally modulated systems, the power spectral density conducted from the intentional radiator to the antenna shall not be greater than 8 dBm in any 3 kHz band during any time interval of continuous transmission.

7.3. EUT Configuration on Measurement

The equipment are installed on the emission Measurement to meet the commission requirements and operating regulations in a manner which tends to maximize its emission characteristics in normal application.

7.4. Operating Condition of EUT

7.4.1. Setup the EUT and simulator as shown as Section 7.1.

7.4.2. Turn on the power of all equipment.

7.4.3. Let the EUT work in TX modes measure it. The transmit frequency are 2402-2480MHz. We select 2402MHz, 2440MHz, and 2480MHz TX frequency to transmit.

7.5. Test Procedure

7.5.1. The transmitter output was connected to the spectrum analyzer through a low loss cable.

7.5.2. Measurement Procedure PKPSD:

7.5.3. This procedure must be used if maximum peak conducted output power was used to demonstrate compliance to the fundamental output power limit, and is optional if the maximum (average) conducted output power was used to demonstrate compliance.

1. Set analyzer center frequency to DTS channel center frequency.
2. Set the span to 1.5 times the DTS channel bandwidth.
3. Set the RBW to: $3 \text{ kHz} \leq \text{RBW} \leq 100 \text{ kHz}$.
4. Set the VBW $\geq 3 \times \text{RBW}$.
5. Detector = peak.
6. Sweep time = auto couple.
7. Trace mode = max hold.
8. Allow trace to fully stabilize.
9. Use the peak marker function to determine the maximum amplitude level.
10. If measured value exceeds limit, reduce RBW (no less than 3kHz) and repeat.

7.5.4. Measurement the maximum power spectral density.

7.6. Test Result

CHANNEL NUMBER	FREQUENCY (MHz)	PSD (dBm/3kHz)	LIMIT (dBm/3kHz)	PASS/FAIL
0	2402	-22.03	8	PASS
19	2440	-21.44	8	PASS
39	2480	-20.65	8	PASS

The spectrum analyzer plots are attached as below.

channel 0

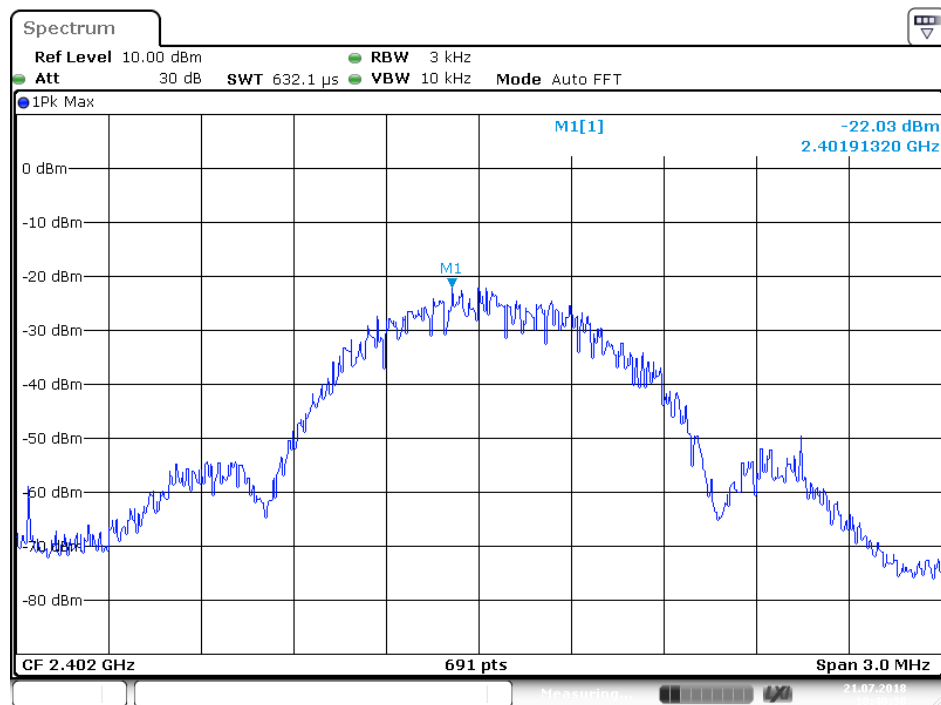

Date: 21.JUL.2018 10:40:38

channel 19

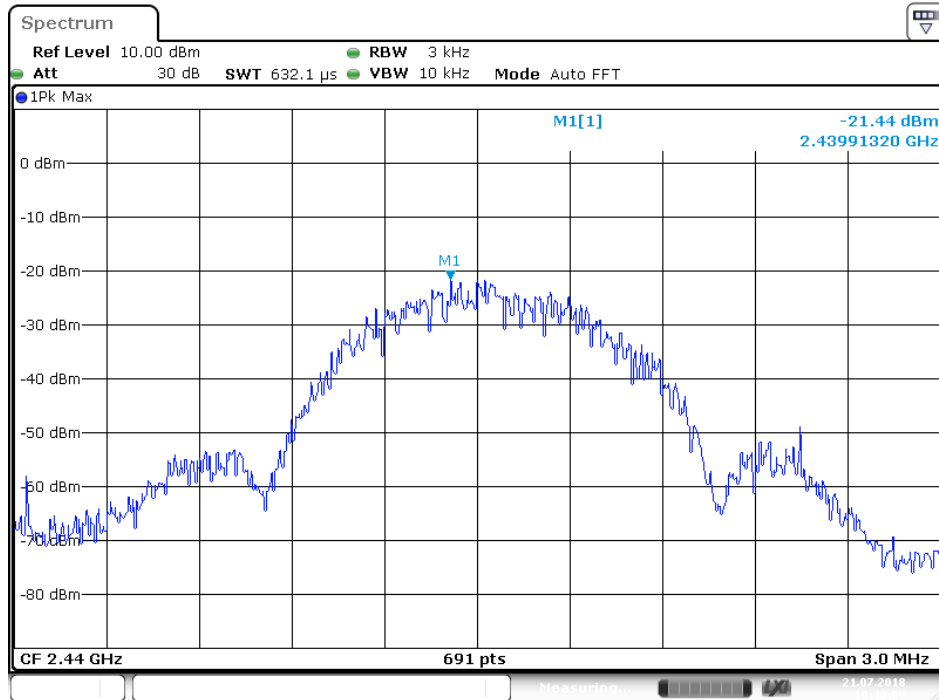

channel 39

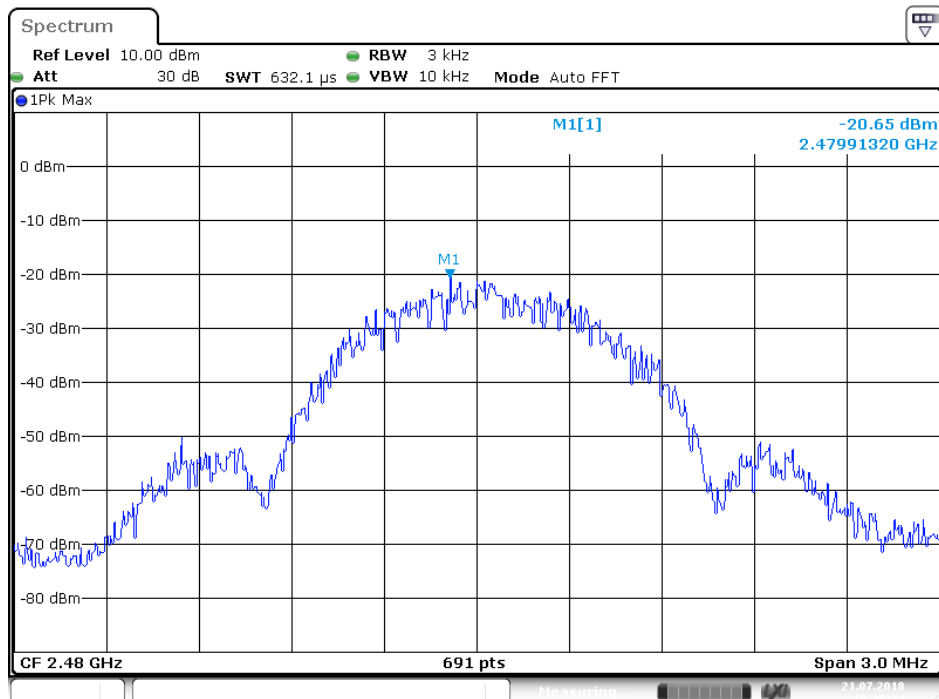

8. BAND EDGE COMPLIANCE TEST

8.1. Block Diagram of Test Setup

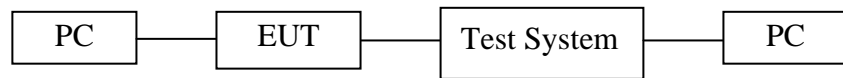

(EUT: Blood Pressure Monitor)

8.2. The Requirement For Section 15.247(d)

Section 15.247(d): In any 100 kHz bandwidth outside the frequency band in which the spread spectrum or digitally modulated intentional radiator is operating, the radio frequency power that is produced by the intentional radiator shall be at least 20 dB below that in the 100 kHz bandwidth within the band that contains the highest level of the desired power, based on either an RF conducted or a radiated measurement, provided the transmitter demonstrates compliance with the peak conducted power limits. If the transmitter complies with the conducted power limits based on the use of RMS averaging over a time interval, as permitted under paragraph (b)(3) of this section, the attenuation required under this paragraph shall be 30 dB instead of 20 dB. Attenuation below the general limits specified in Section 15.209(a) is not required. In addition, radiated emissions which fall in the restricted bands, as defined in Section 15.205(a), must also comply with the radiated emission limits specified in Section 15.209(a).

8.3. EUT Configuration on Measurement

The equipment are installed on the emission Measurement to meet the commission requirements and operating regulations in a manner which tends to maximize its emission characteristics in normal application.

8.4. Operating Condition of EUT

8.4.1. Setup the EUT and simulator as shown as Section 8.1.

8.4.2. Turn on the power of all equipment.

8.4.3. Let the EUT work in TX modes measure it. The transmit frequency are 2402-2480MHz. We select 2402MHz, 2480MHz TX frequency to transmit.

8.5. Test Procedure

Conducted Band Edge:

8.5.1. The transmitter output was connected to the spectrum analyzer via a low loss cable.

8.5.2. Set RBW of spectrum analyzer to 100 kHz and VBW to 300 kHz.

8.5.3. Radiate Band Edge:

8.5.4. The EUT is placed on a turntable, which is 0.1m above the ground plane and worked at highest radiated power.

8.5.5. The turntable was rotated for 360 degrees to determine the position of maximum emission level.

8.5.6. EUT is set 3m away from the receiving antenna, which is varied from 1m to 4m to find out the highest emission.

8.5.7. Set the spectrum analyzer in the following setting in order to capture the lower and upper band-edges of the emission:

8.5.8. RBW=1MHz, VBW=1MHz

8.5.9. The band edges was measured and recorded.

8.6. Test Result

Pass

Channel	Frequency	Delta peak to band emission	Limit(dBc)
0	2.398GHz	34.92	20
39	2.484GHz	42.54	20

channel 0

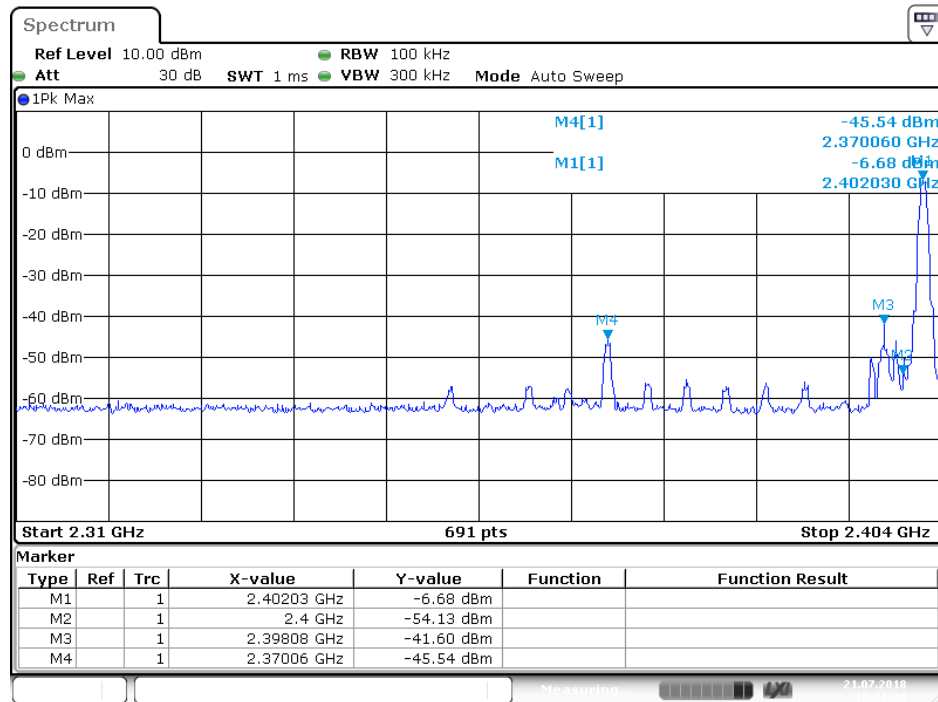

Date: 21.JUL.2018 10:31:49

channel 39

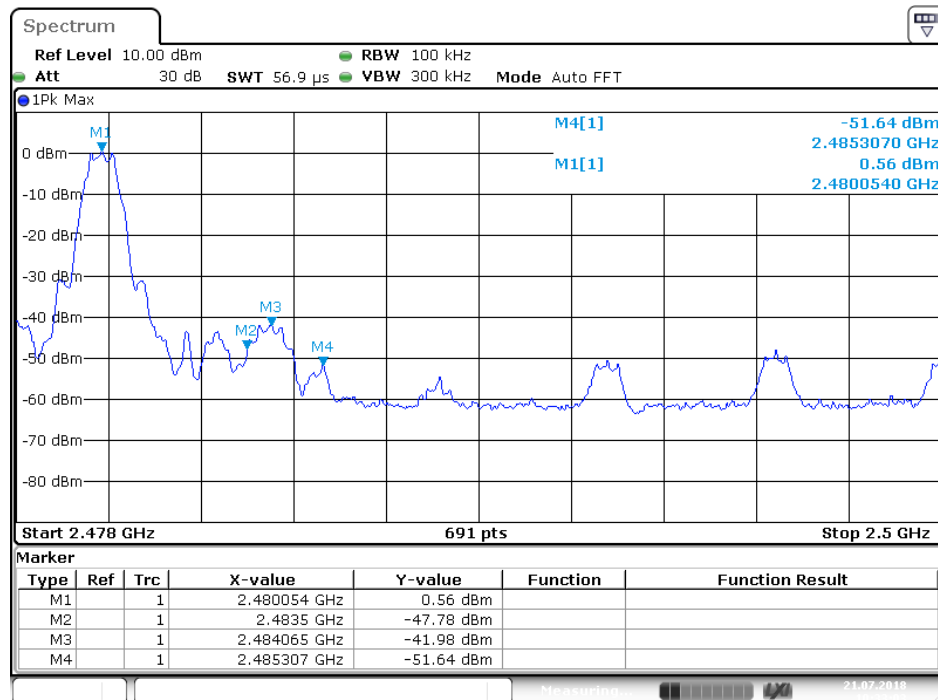

Date: 21.JUL.2018 10:33:03

Shenzhen Accurate Technology Co., Ltd.

Address: 1/F., Building A, Changyuan New Material Port, Science & Industry Park, Nanshan District, Shenzhen, Guangdong, P.R. China

Tel: +86-755-26503290

Fax: +86-755-26503396

E-mail: webmaster@atc-lab.com

Http://www.atc-lab.com

Radiated Band Edge Result



ACCURATE TECHNOLOGY CO., LTD.

 F1,Bldg,A,Changyuan New Material Port Keyuan Rd,
 Science & Industry Park,Nanshan Shenzhen,P.R.China

 Site: 2# Chamber
 Tel:+86-0755-26503290
 Fax:+86-0755-26503396

Job No.: LGW2018 #1838	Polarization: Horizontal
Standard: FCC (Band Edge)	Power Source: DC 6V
Test item: Radiation Test	Date: 18/07/21/
Temp.(C)/Hum.(%) 23 C / 48 %	Time:
EUT: Blood Pressure Monitor	Engineer Signature: WADE
Mode: TX 2402MHz	Distance: 3m
Model: BW-BT1	
Manufacturer: Shenzhen Kingyield Technology Co., Ltd.	

Note:

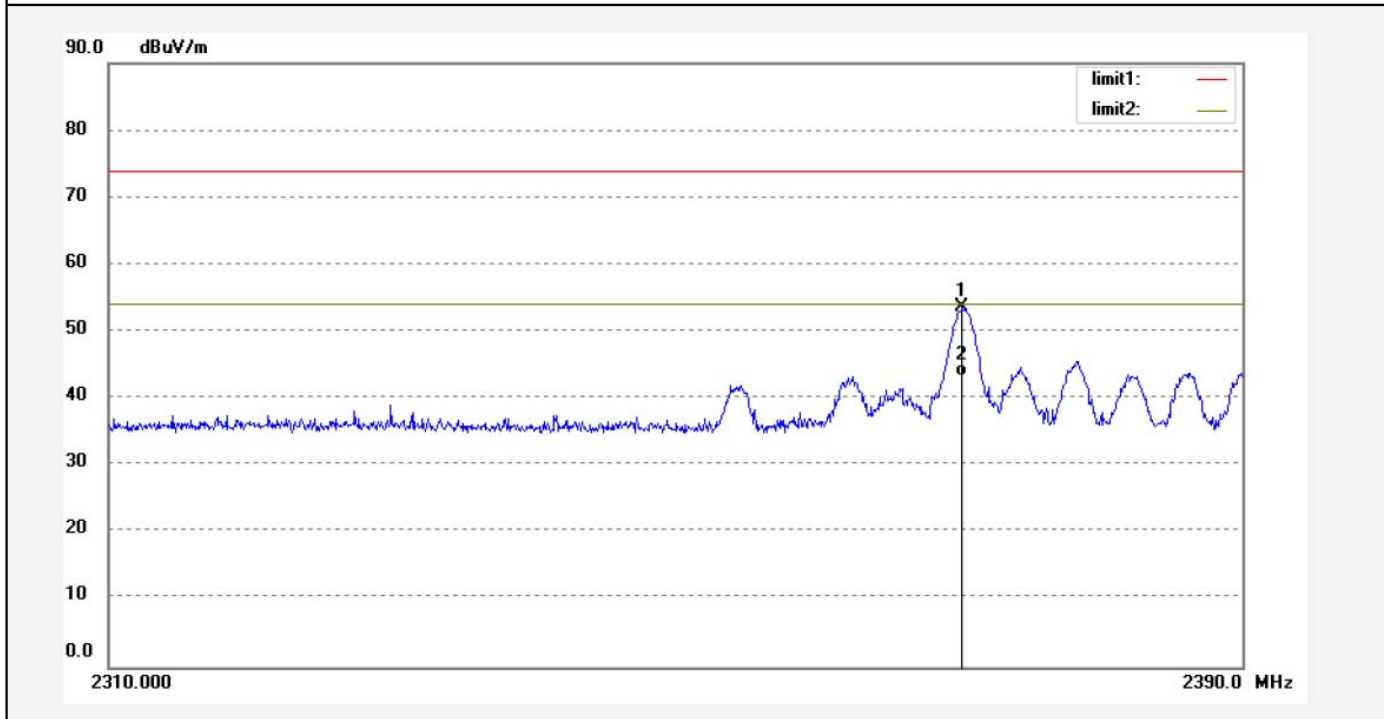

No.	Freq. (MHz)	Reading (dBuV/m)	Factor (dB)	Result (dBuV/m)	Limit (dBuV/m)	Margin (dB)	Detector	Height (cm)	Degree (deg.)	Remark
1	2370.000	53.13	0.63	53.76	74.00	-20.24	peak			
2	2370.000	42.61	0.63	43.24	54.00	-10.76	AVG			

Shenzhen Accurate Technology Co., Ltd.

Address: 1/F., Building A, Changyuan New Material Port, Science & Industry Park, Nanshan District, Shenzhen, Guangdong, P.R. China

Tel: +86-755-26503290

Fax: +86-755-26503396

E-mail: webmaster@atc-lab.com

Http://www.atc-lab.com

Job No.: LGW2018 #1839

Standard: FCC (Band Edge)

Test item: Radiation Test

Temp.(C)/Hum.(%) 23 C / 48 %

EUT: Blood Pressure Monitor

Mode: TX 2402MHz

Model: BW-BT1

Manufacturer: Shenzhen Kingyield Technology Co., Ltd.

Polarization: Vertical

Power Source: DC 6V

Date: 18/07/21/

Time:

Engineer Signature: WADE

Distance: 3m

Note:

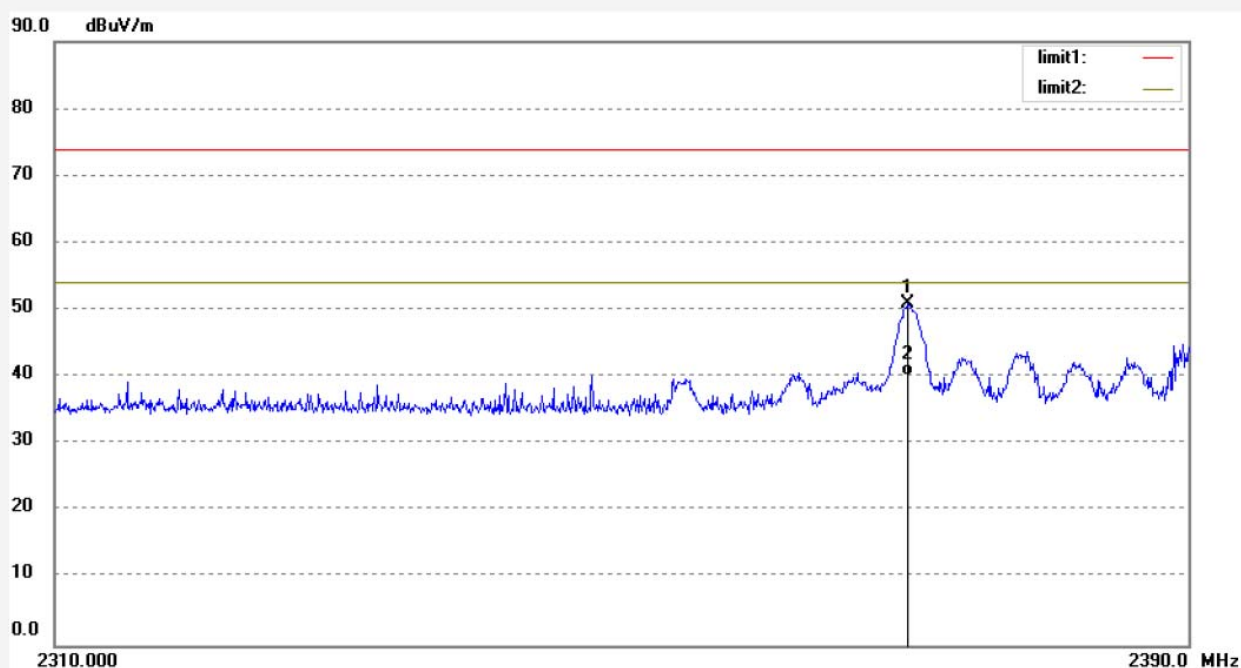

No.	Freq. (MHz)	Reading (dBuV/m)	Factor (dB)	Result (dBuV/m)	Limit (dBuV/m)	Margin (dB)	Detector	Height (cm)	Degree (deg.)	Remark
1	2369.920	50.34	0.63	50.97	74.00	-23.03	peak			
2	2369.920	39.51	0.63	40.14	54.00	-13.86	AVG			

Job No.: LGW2018 #1845

Standard: FCC (Band Edge)

Test item: Radiation Test

Temp.(C)/Hum.(%) 23 C / 48 %

EUT: Blood Pressure Monitor

Mode: TX 2480MHz

Model: BW-BT1

Manufacturer: Shenzhen Kingyield Technology Co., Ltd.

Polarization: Horizontal

Power Source: DC 6V

Date: 18/07/21/

Time:

Engineer Signature: WADE

Distance: 3m

Note:

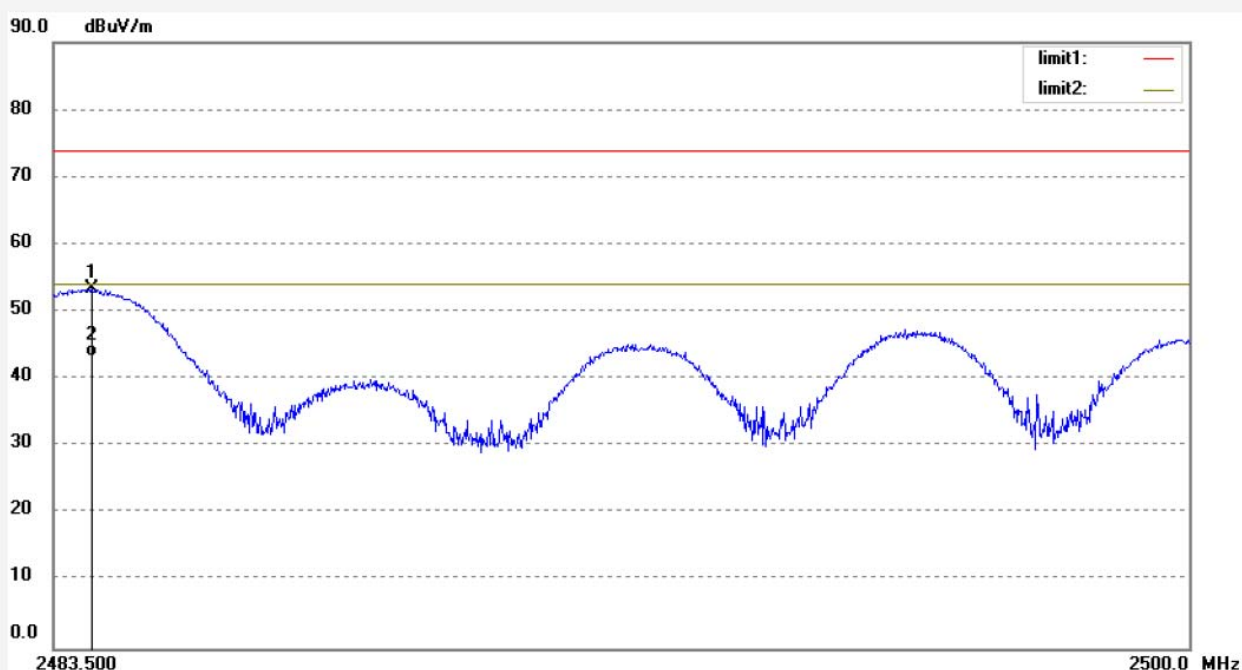

No.	Freq. (MHz)	Reading (dBuV/m)	Factor (dB)	Result (dBuV/m)	Limit (dBuV/m)	Margin (dB)	Detector	Height (cm)	Degree (deg.)	Remark
1	2484.061	52.42	1.09	53.51	74.00	-20.49	peak			
2	2484.061	42.18	1.09	43.27	54.00	-10.73	AVG			

Job No.: LGW2018 #1844	Polarization: Vertical
Standard: FCC (Band Edge)	Power Source: DC 6V
Test item: Radiation Test	Date: 18/07/21/
Temp.(C)/Hum.(%) 23 C / 48 %	Time:
EUT: Blood Pressure Monitor	Engineer Signature: WADE
Mode: TX 2480MHz	Distance: 3m
Model: BW-BT1	
Manufacturer: Shenzhen Kingyield Technology Co., Ltd.	

Note:

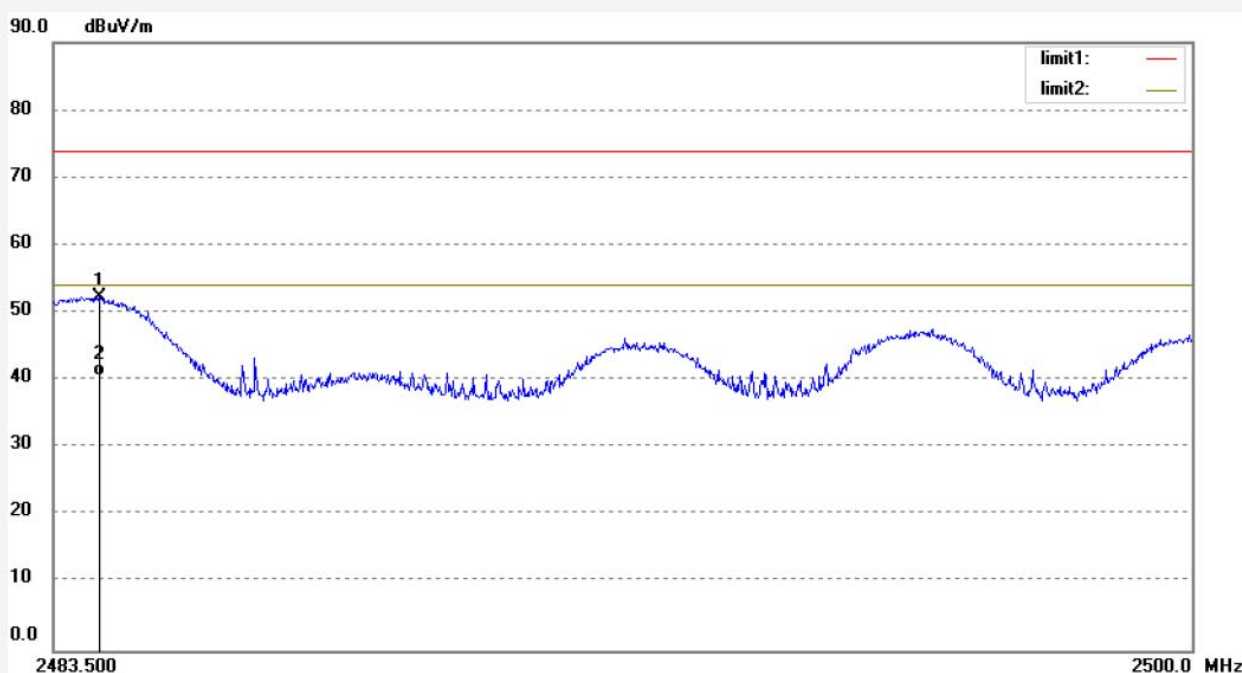

No.	Freq. (MHz)	Reading (dBuV/m)	Factor (dB)	Result (dBuV/m)	Limit (dBuV/m)	Margin (dB)	Detector	Height (cm)	Degree (deg.)	Remark
1	2484.160	51.16	1.09	52.25	74.00	-21.75	peak			
2	2484.160	39.42	1.09	40.51	54.00	-13.49	AVG			

Note:

1. Emissions attenuated more than 20 dB below the permissible value are not reported.
2. The field strength is calculated by adding the antenna factor, high pass filter loss(if used) and cable loss, and subtracting the amplifier gain(if any)from the measured reading. The basic equation calculation is as follows:

$$\text{Result} = \text{Reading} + \text{Corrected Factor}$$

Shenzhen Accurate Technology Co., Ltd.

Address: 1/F., Building A, Changyuan New Material Port, Science & Industry Park, Nanshan District, Shenzhen, Guangdong, P.R. China

Tel: +86-755-26503290

Fax: +86-755-26503396

E-mail: webmaster@atc-lab.com

Http://www.atc-lab.com

9. RADIATED SPURIOUS EMISSION TEST

9.1. Block Diagram of Test Setup

9.1.1. Block diagram of connection between the EUT and peripherals

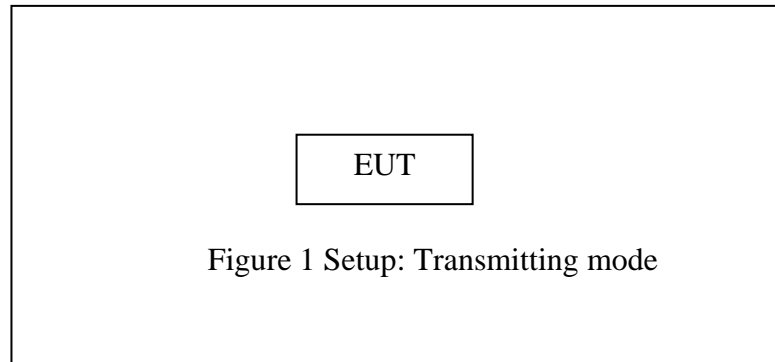

9.1.2. Semi-Anechoic Chamber Test Setup Diagram

(A) Radiated Emission Test Set-Up, Frequency below 30MHz

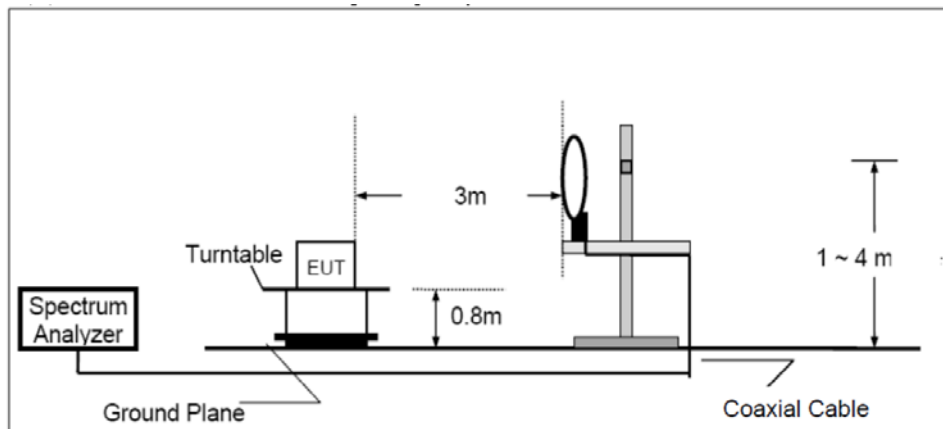

(B) Radiated Emission Test Set-Up, Frequency below 1GHz

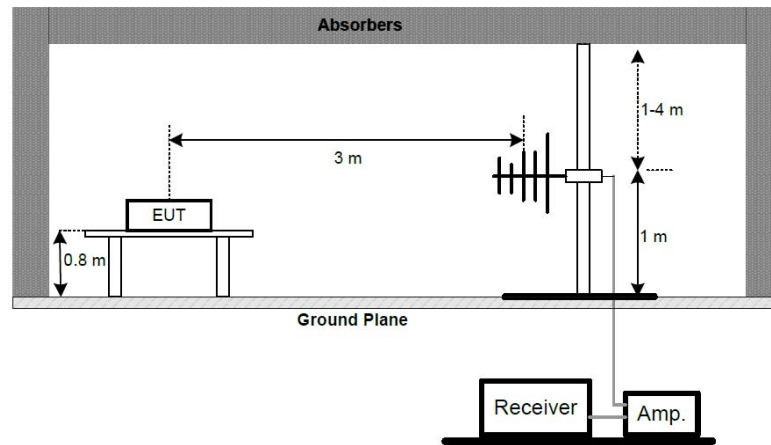

Above 1GHz:

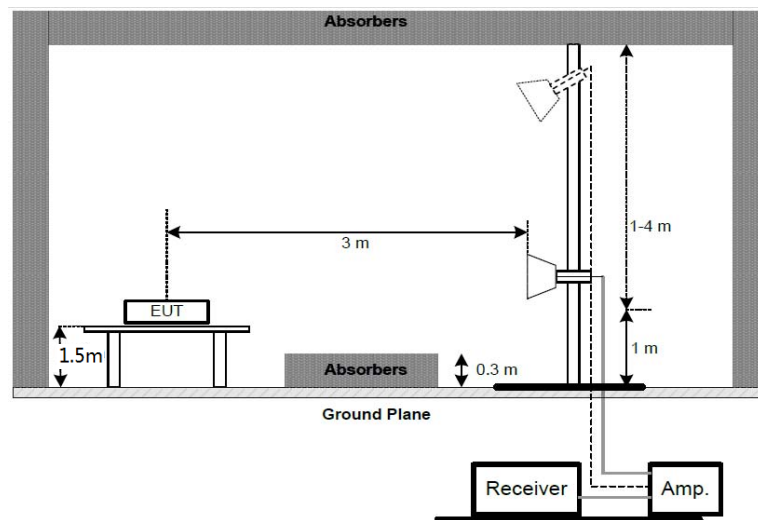

9.2. The Limit For Section 15.247(d)

Section 15.247(d): In any 100 kHz bandwidth outside the frequency band in which the spread spectrum or digitally modulated intentional radiator is operating, the radio frequency power that is produced by the intentional radiator shall be at least 20 dB below that in the 100 kHz bandwidth within the band that contains the highest level of the desired power, based on either an RF conducted or a radiated measurement, provided the transmitter demonstrates compliance with the peak conducted power limits. If the transmitter complies with the conducted power limits based on the use of RMS averaging over a time interval, as permitted under paragraph (b)(3) of this section, the attenuation required under this paragraph shall be 30 dB instead of 20 dB. Attenuation below the general limits specified in Section 15.209(a) is not required. In addition, radiated emissions which fall in the restricted bands, as defined in Section 15.205(a), must also comply with the radiated emission limits specified in Section 15.209(a).

9.3.Restricted bands of operation

9.3.1.FCC Part 15.205 Restricted bands of operation

(a) Except as shown in paragraph (d) of this section, Only spurious emissions are permitted in any of the frequency bands listed below:

MHz	MHz	MHz	GHz
0.090-0.110	16.42-16.423	399.9-410	4.5-5.15
¹ 0.495-0.505	16.69475-16.69525	608-614	5.35-5.46
2.1735-2.1905	16.80425-16.80475	960-1240	7.25-7.75
4.125-4.128	25.5-25.67	1300-1427	8.025-8.5
4.17725-4.17775	37.5-38.25	1435-1626.5	9.0-9.2
4.20725-4.20775	73-74.6	1645.5-1646.5	9.3-9.5
6.215-6.218	74.8-75.2	1660-1710	10.6-12.7
6.26775-6.26825	108-121.94	1718.8-1722.2	13.25-13.4
6.31175-6.31225	123-138	2200-2300	14.47-14.5
8.291-8.294	149.9-150.05	2310-2390	15.35-16.2
8.362-8.366	156.52475-156.52525	2483.5-2500	17.7-21.4
8.37625-8.38675	156.7-156.9	2690-2900	22.01-23.12
8.41425-8.41475	162.0125-167.17	3260-3267	23.6-24.0
12.29-12.293	167.72-173.2	3332-3339	31.2-31.8
12.51975-12.52025	240-285	3345.8-3358	36.43-36.5
12.57675-12.57725	322-335.4	3600-4400	(²)
13.36-13.41			

¹Until February 1, 1999, this restricted band shall be 0.490-0.510

²Above 38.6

(b) Except as provided in paragraphs (d) and (e), the field strength of emission appearing within these frequency bands shall not exceed the limits shown in Section 15.209. At frequencies equal to or less than 1000MHz, Compliance with the limits in Section 15.209 shall be demonstrated using measurement instrumentation employing a CISPR quasi-peak detector. Above 1000MHz, compliance with the emission limits in Section 15.209 shall be demonstrated based on the average value of the measured emissions. The provisions in Section 15.35 apply to these measurements.

9.4.Configuration of EUT on Measurement

The equipment are installed on Radiated Emission Measurement to meet the commission requirements and operating regulations in a manner which tends to maximize its emission characteristics in normal application.

9.5. Operating Condition of EUT

9.5.1. Setup the EUT and simulator as shown as Section 9.1.

9.5.2. Turn on the power of all equipment.

9.5.3. Let the EUT work in TX modes measure it. The transmit frequency are 2402-2480MHz. We select 2402MHz, 2440MHz, and 2480MHz TX frequency to transmit.

9.6. Test Procedure

The EUT and its simulators are placed on a turntable, which is 0.8 meter high above ground (Below 1GHz). The EUT and its simulators are placed on a turntable, which is 1.5 meter high above ground (Above 1GHz). The turntable can rotate 360 degrees to determine the position of the maximum emission level. EUT is set 3.0 meters away from the receiving antenna, which is mounted on an antenna tower. The antenna can be moved up and down between 1.0 meter and 4 meters to find out the maximum emission level. Broadband antenna (calibrated bi-log antenna) is used as receiving antenna. Both horizontal and vertical polarizations of the antenna are set on measurement. In order to find the maximum emission levels, all of the EUT location must be manipulated according to ANSI C63.10:2013 on radiated emission measurement. The EUT was tested in 3 orthogonal planes.

The bandwidth of test receiver is set at 9 kHz in below 30MHz. and set at 120 kHz in 30-1000MHz, and 1MHz in above 1000MHz.

The frequency range from 9 kHz to 25GHz is checked.

The final measurement in band 9-90 kHz, 110-490 kHz and above 1000MHz is performed with Average detector. Except those frequency bands mention above, the final measurement for frequencies below 1000MHz is performed with Quasi Peak detector.

The field strength is calculated by adding the antenna factor, and cable loss, and subtracting the amplifier gain from the measured reading. The basic equation calculation is as follows:

Result = Reading + Corrected Factor

Where Corrected Factor = Antenna Factor + Cable Loss – Amplifier Gain

9.7. The Field Strength of Radiation Emission Measurement Results

PASS.

Note: 1. Emissions attenuated more than 20 dB below the permissible value are not reported.

2. *: Denotes restricted band of operation.

FCC PART15C(9K-30MHz)

ACCURATE TECHNOLOGY CO.,LTD

FCC Class B 3m Radiated

EUT: Blood Pressure Monitor M/N:BW-BT1
 Manufacturer: Shenzhen Kingyieid Technology Co., Ltd.
 Operating Condition: TX 2402MHz
 Test Site: 2# Chamber
 Operator: WADE
 Test Specification: DC 6V
 Comment: X
 Start of Test: 2018-7-18 /

SCAN TABLE: "LFRE Fin"

Short Description:			SUB STD VTERM2 1.70			
Start	Stop	Step	Detector	Meas. Time	IF Bandw.	Transducer
9.0 kHz	150.0 kHz	100.0 Hz	QuasiPeak	1.0 s	200 Hz	1516M
150.0 kHz	30.0 MHz	5.0 kHz	QuasiPeak	1.0 s	9 kHz	1516M

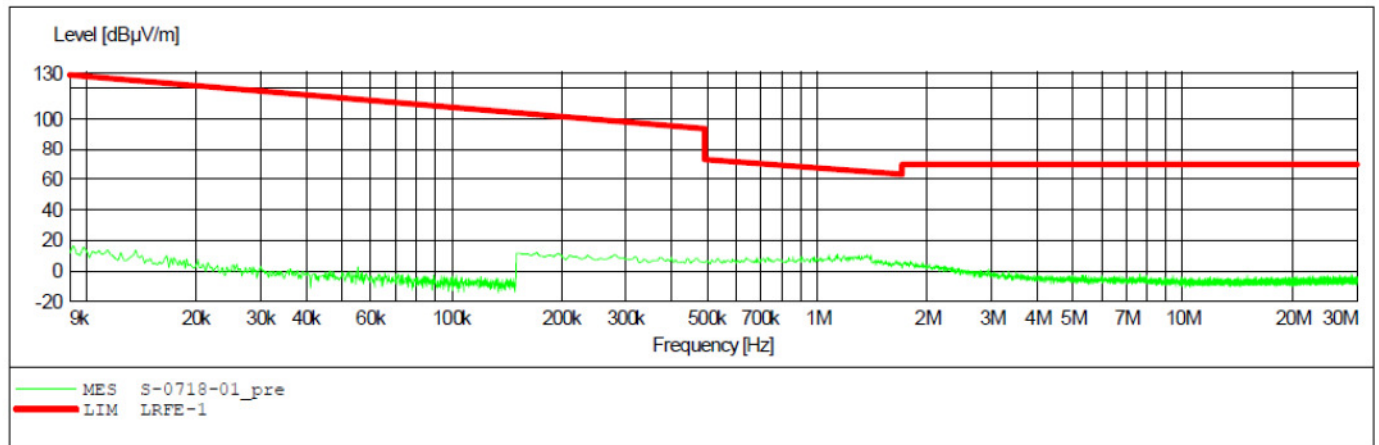

ACCURATE TECHNOLOGY CO., LTD

FCC Class B 3m Radiated

EUT: Blood Pressure Monitor M/N:BW-BT1
 Manufacturer: Shenzhen Kingyfield Technology Co., Ltd.
 Operating Condition: TX 2402MHz
 Test Site: 2# Chamber
 Operator: WADE
 Test Specification: DC 6V
 Comment: Y
 Start of Test: 2018-7-18 /

SCAN TABLE: "LFRE Fin"

Short Description:			SUB STD VTERM2 1.70			
Start	Stop	Step	Detector	Meas. Time	IF Bandw.	Transducer
9.0 kHz	150.0 kHz	100.0 Hz	QuasiPeak	1.0 s	200 Hz	1516M
150.0 kHz	30.0 MHz	5.0 kHz	QuasiPeak	1.0 s	9 kHz	1516M

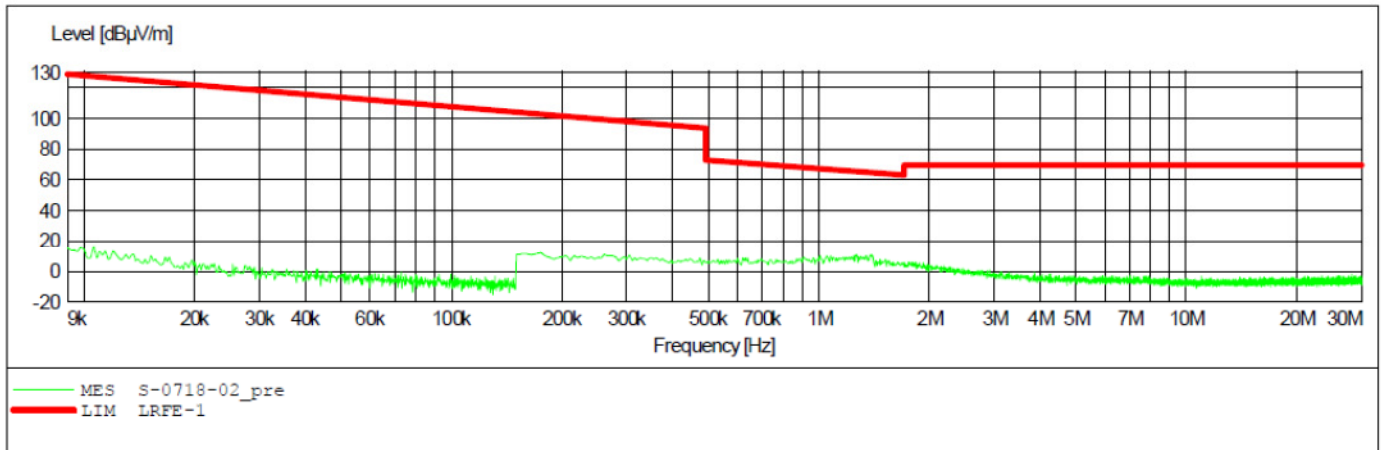

ACCURATE TECHNOLOGY CO., LTD

FCC Class B 3m Radiated

EUT: Blood Pressure Monitor M/N:BW-BT1
 Manufacturer: Shenzhen Kingyieid Technology Co., Ltd.
 Operating Condition: TX 2402MHz
 Test Site: 2# Chamber
 Operator: WADE
 Test Specification: DC 6V
 Comment: Z
 Start of Test: 2018-7-18 /

SCAN TABLE: "LFRE Fin"

Short Description:			SUB STD VTERM2 1.70			
Start Frequency	Stop Frequency	Step Width	Detector	Meas. Time	IF Bandw.	Transducer
9.0 kHz	150.0 kHz	100.0 Hz	QuasiPeak	1.0 s	200 Hz	1516M
150.0 kHz	30.0 MHz	5.0 kHz	QuasiPeak	1.0 s	9 kHz	1516M

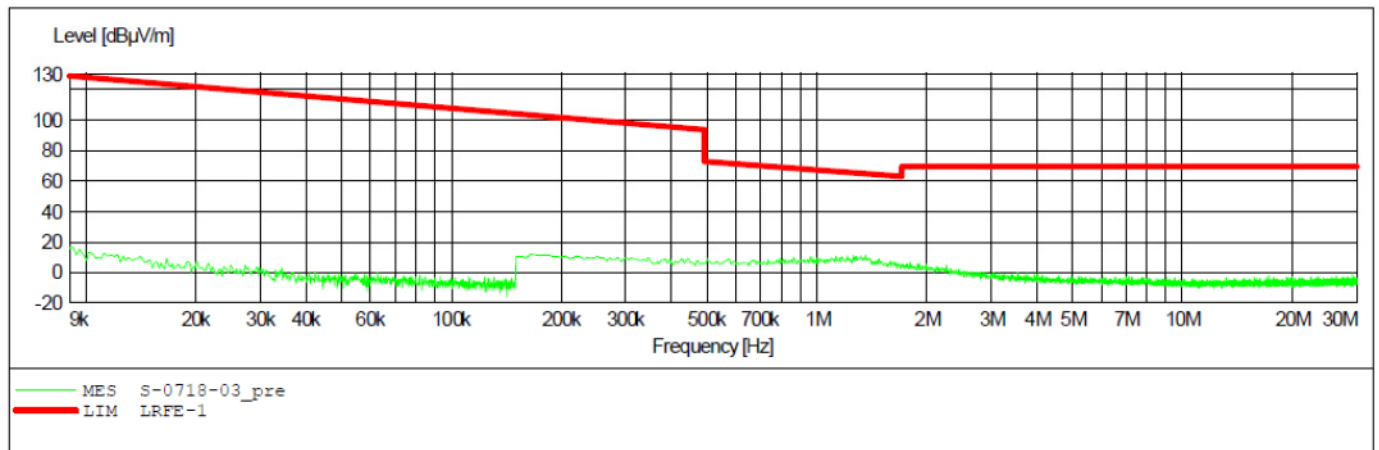

ACCURATE TECHNOLOGY CO., LTD

FCC Class B 3m Radiated

EUT: Blood Pressure Monitor M/N:BW-BT1
 Manufacturer: Shenzhen Kingyieid Technology Co., Ltd.
 Operating Condition: TX 2440MHz
 Test Site: 2# Chamber
 Operator: WADE
 Test Specification: DC 6V
 Comment: X
 Start of Test: 2018-7-18 /

SCAN TABLE: "LFRE Fin"

Short Description:			SUB STD VTERM2 1.70			
Start	Stop	Step	Detector	Meas. Time	IF Bandw.	Transducer
9.0 kHz	150.0 kHz	100.0 Hz	QuasiPeak	1.0 s	200 Hz	1516M
150.0 kHz	30.0 MHz	5.0 kHz	QuasiPeak	1.0 s	9 kHz	1516M

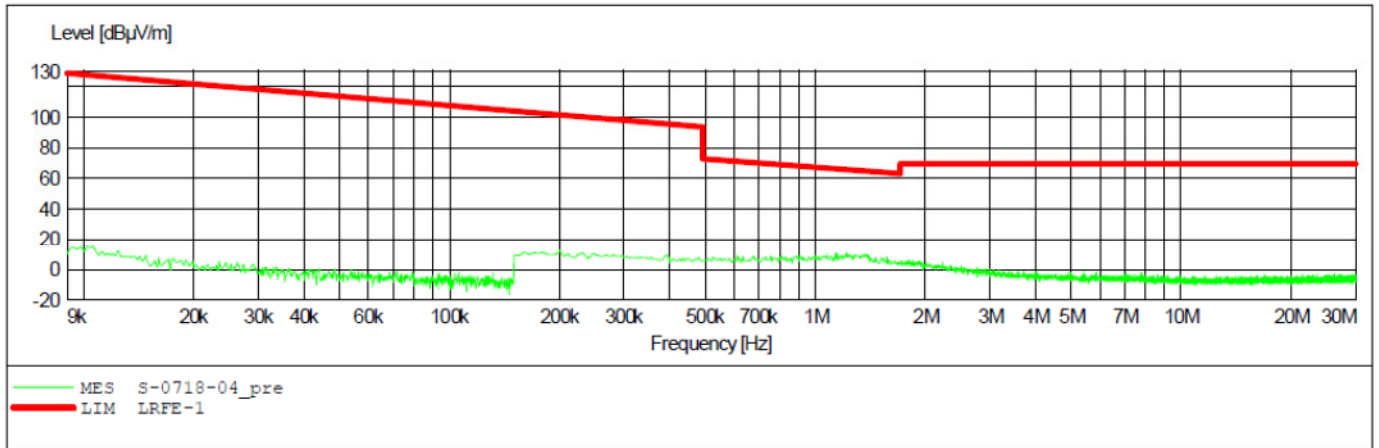

ACCURATE TECHNOLOGY CO., LTD

FCC Class B 3m Radiated

EUT: Blood Pressure Monitor M/N:BW-BT1
 Manufacturer: Shenzhen Kingyield Technology Co., Ltd.
 Operating Condition: TX 2440MHz
 Test Site: 2# Chamber
 Operator: WADE
 Test Specification: DC 6V
 Comment: Y
 Start of Test: 2018-7-18 /

SCAN TABLE: "LFRE Fin"

Start Frequency	Stop Frequency	Step Width	Detector	Meas. Time	IF Bandw.	Transducer
9.0 kHz	150.0 kHz	100.0 Hz	QuasiPeak	1.0 s	200 Hz	1516M
150.0 kHz	30.0 MHz	5.0 kHz	QuasiPeak	1.0 s	9 kHz	1516M

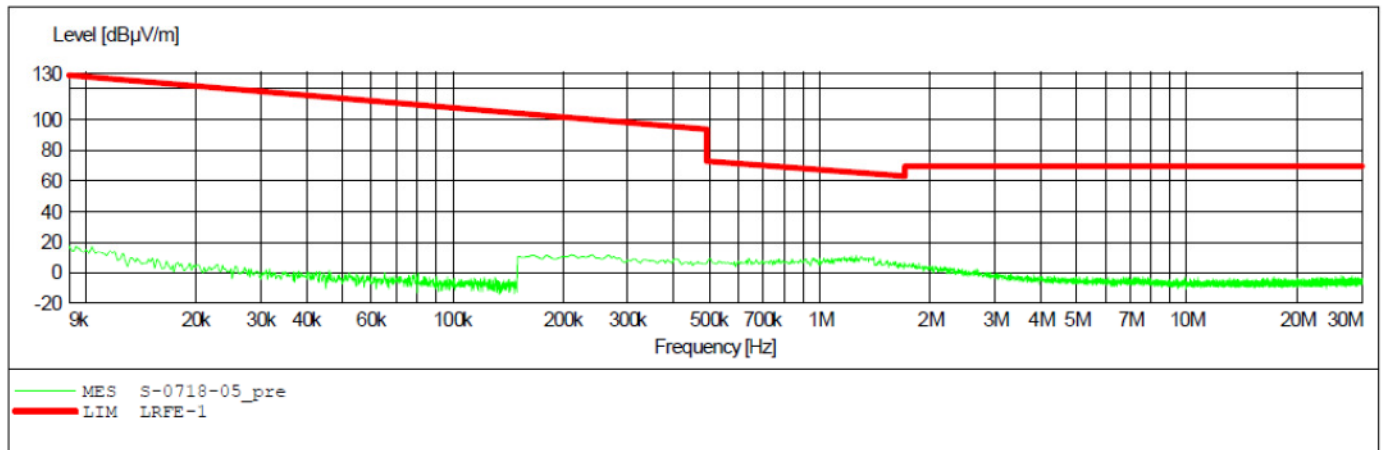

ACCURATE TECHNOLOGY CO., LTD

FCC Class B 3m Radiated

EUT: Blood Pressure Monitor M/N:BW-BT1
 Manufacturer: Shenzhen Kingyield Technology Co., Ltd.
 Operating Condition: TX 2440MHz
 Test Site: 2# Chamber
 Operator: WADE
 Test Specification: DC 6V
 Comment: Z
 Start of Test: 2018-7-18 /

SCAN TABLE: "LFRE Fin"

Short Description:			SUB STD VTERM2 1.70			
Start	Stop	Step	Detector	Meas.	IF	Transducer
Frequency	Frequency	Width		Time	Bandw.	
9.0 kHz	150.0 kHz	100.0 Hz	QuasiPeak	1.0 s	200 Hz	1516M
150.0 kHz	30.0 MHz	5.0 kHz	QuasiPeak	1.0 s	9 kHz	1516M

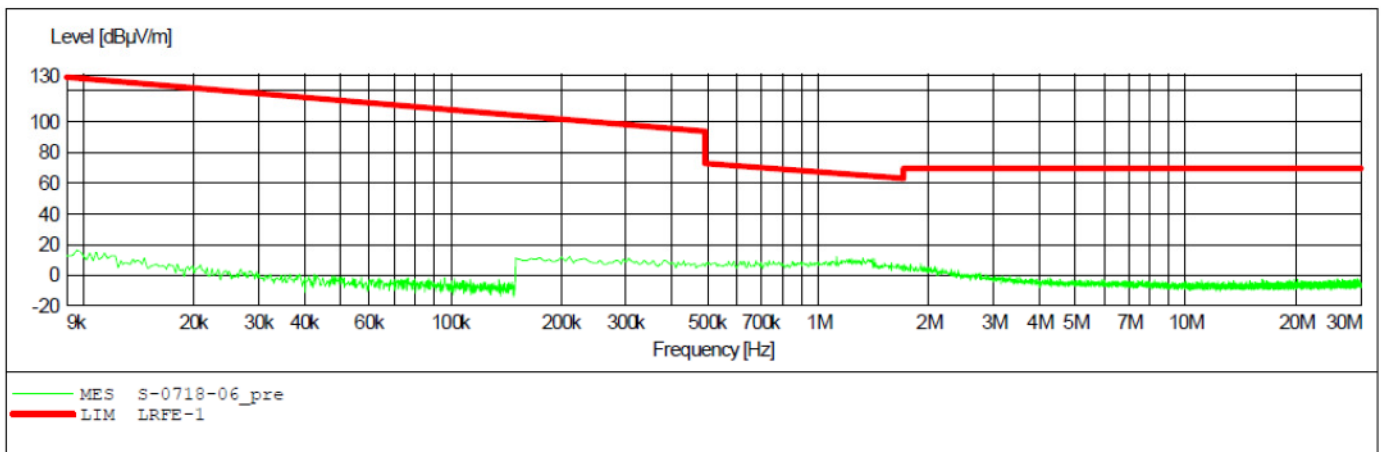

ACCURATE TECHNOLOGY CO., LTD**FCC Class B 3m Radiated**

EUT: Blood Pressure Monitor M/N:BW-BT1
 Manufacturer: Shenzhen Kingyield Technology Co., Ltd.
 Operating Condition: TX 2480MHz
 Test Site: 2# Chamber
 Operator: WADE
 Test Specification: DC 6V
 Comment: X
 Start of Test: 2018-7-18 /

SCAN TABLE: "LFRE Fin"

Start Frequency	Stop Frequency	Step Width	Detector	Meas. Time	IF Bandw.	Transducer
9.0 kHz	150.0 kHz	100.0 Hz	QuasiPeak	1.0 s	200 Hz	1516M
150.0 kHz	30.0 MHz	5.0 kHz	QuasiPeak	1.0 s	9 kHz	1516M

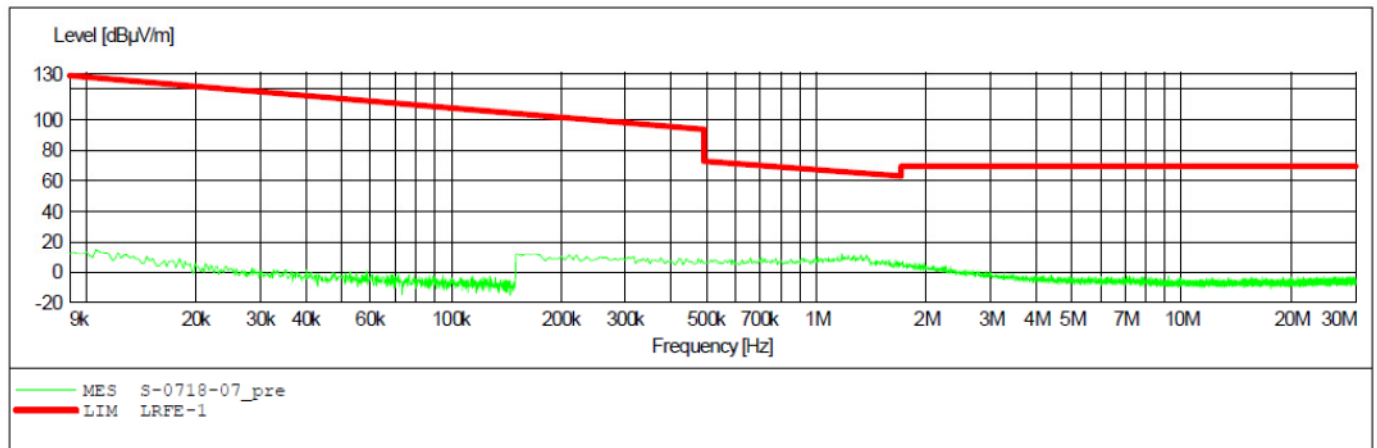

ACCURATE TECHNOLOGY CO., LTD

FCC Class B 3m Radiated

EUT: Blood Pressure Monitor M/N:BW-BT1
 Manufacturer: Shenzhen Kingyeld Technology Co., Ltd.
 Operating Condition: TX 2480MHz
 Test Site: 2# Chamber
 Operator: WADE
 Test Specification: DC 6V
 Comment: Y
 Start of Test: 2018-7-18 /

SCAN TABLE: "LFRE Fin"

Start	Stop	Step	Detector	Meas. Time	IF Bandw.	Transducer
9.0 kHz	150.0 kHz	100.0 Hz	QuasiPeak	1.0 s	200 Hz	1516M
150.0 kHz	30.0 MHz	5.0 kHz	QuasiPeak	1.0 s	9 kHz	1516M

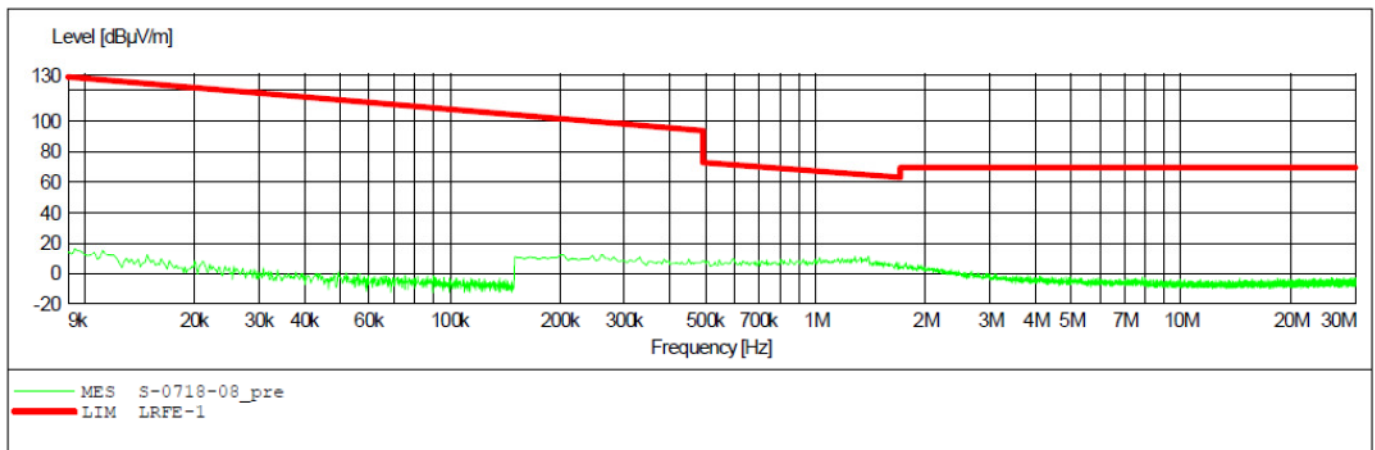

ACCURATE TECHNOLOGY CO., LTD**FCC Class B 3m Radiated**

EUT: Blood Pressure Monitor M/N:BW-BT1
Manufacturer: Shenzhen Kingyeld Technology Co., Ltd.
Operating Condition: TX 2480MHz
Test Site: 2# Chamber
Operator: WADE
Test Specification: DC 6V
Comment: Z
Start of Test: 2018-7-18 /

SCAN TABLE: "LFRE Fin"

Short Description:			SUB STD VTERM2 1.70			
Start	Stop	Step	Detector	Meas.	IF	Transducer
Frequency	Frequency	Width		Time	Bandw.	
9.0 kHz	150.0 kHz	100.0 Hz	QuasiPeak	1.0 s	200 Hz	1516M
150.0 kHz	30.0 MHz	5.0 kHz	QuasiPeak	1.0 s	9 kHz	1516M

