



RF Test Report

Issued Date: Sep. 20, 2018

Applicant : Wuunet Technology Co., Ltd
Product Type : Kalay Home Smart Light Camera 1080P
Model Number : WB102U
FCC ID : 2AF8P-WB102U
EUT Rated Voltage : AC100-240 V, 50-60 Hz, 0.12 A
Test Voltage : 120 Vac / 60 Hz
Receive Date : Jul. 19, 2018
Test Period : Jul. 25 ~ Jul. 30, 2018
Applicable Standard : FCC 47 CFR PART 15 SUBPART C
ANSI C63.10:2013
Test Result : Complied

Testing Laboratory

A Test Lab Techno Corp.

101-104, 1F, A building, Safflower ridge industrial area,
Taoyuan street, Nanshan district, Shenzhen
Tel : +86-755-23987770 / Fax : +86-755-26637771
<http://www.atl-lab.com.tw/e-index.htm>



Note: This report shall not be reproduced except in full, without the written approval of A Test Lab Techno Corp. This document may be altered or revised by A Test Lab Techno Corp. personnel only and shall be noted in the revision section of the document. The client should not use it to claim product endorsement by A2LA, or any government agencies. The test results in the report only apply to the tested sample.

Approved By : Hai Wang Reviewed By : Mick Zhang
(Manager) (Hai Wang) (Testing Engineer) (Mick Zhang)



Revision History

Rev.	Issue Date	Revisions
00	Sep. 20, 2018	Initial Issue

TABLE OF CONTENTS

1	General Information	4
2	EUT Description	6
3	Test Methodology	7
3.1.	Mode of Operation	7
3.2.	EUT Exercise Software	11
3.3.	Configuration of Test System Details	12
3.4.	Test Instruments	13
3.5.	Test Site Environment	14
4	Measurement Procedure	15
4.1.	AC Power Line Conducted Emission Measurement	15
4.2.	Radiated Emission Measurement	17
4.3.	Maximum Conducted Output Power Measurement	22
4.4.	6 dB RF Bandwidth Measurement	23
4.5.	Maximum Power Spectral Density Measurement	24
4.6.	Out of Band Conducted Emissions Measurement	25
4.7.	Antenna Measurement	26
5	Test Results	27
	Annex A. Conducted Emission	27
	Annex B. Conducted Test Results	29
	Annex C. Radiated Emission Test Results	53



1 General Information

1.1 Summary of Test Result

Standard	Item	Result	Remark
15.247			
15.207	AC Power Conducted Emission	PASS	-----
Standard	Item	Result	Remark
15.247			
15.247(d)	Transmitter Radiated Emissions	PASS	-----
15.247(b)(3)	Max. Output Power	PASS	-----
15.247(a)(2)	6 dB RF Bandwidth	PASS	-----
15.247(e)	Maximum Power Spectral Density	PASS	-----
15.247(d)	Out of Band Conducted Spurious Emission	PASS	-----
15.203	Antenna Requirement	PASS	-----

Standard	Description
CFR47, Part 15, Subpart C §15.247	Intentional Radiators
ANSI C63. 10: 2013	American National Standard of Procedures for Compliance Testing of Unlicensed Wireless Devices
ANSI C63. 4: 2014	American National Standard for methods of measurement of radio – noise emissions from low-voltage electrical and electronic equipment in the range of 9 kHz to 40 GHz
KDB558074 D01 v04	GUIDANCE FOR PERFORMING COMPLIANCE MEASUREMENTS ON DIGITAL TRANSMISSION SYSTEMS (DTS) OPERATING UNDER SECTION 15.247

The test results of this report relate only to the tested sample(s) identified in this report. Manufacturer or whom it may concern should recognize the pass or fail of the test result.



A Test Lab Techno Corp. tested the above equipment under the requirements outlined in the above standards. All indications of Pass/Fail in this report are opinions expressed by A Test Lab Techno Corp. Based on interpretations and/or observations of test results. Measurement Uncertainties were not taken into account and are published for informational purposes only. The test results show that the equipment tested is capable of demonstrating compliance with the requirements as documented in this report.

A Test Lab Techno Corp. will not be liable for any loss or damage resulting from false, inaccurate, inappropriate or incomplete product information provided by the customer.

This test report is electronically signed and valid without handwriting signature. For verification of the electronic signatures, the public keys can be requested at the testing laboratory.

1.2 Measurement Uncertainty

Test Item	Frequency Range	Uncertainty (dB)
Conducted Emission	9 kHz ~ 150 kHz	2.7
	150 kHz ~ 30 MHz	2.7
Radiated Emission	9 kHz ~ 30 MHz	1.7
	30 MHz ~ 1000 MHz	5.7
	1000 MHz ~ 18000 MHz	5.5
	18000 MHz ~ 26500 MHz	4.8
	26500 MHz ~ 40000 MHz	4.8
Conducted Output Power	+0.27 dB / -0.28 dB	
RF Bandwidth	4.96%	
Power Spectral Density	+0.71 dB / -0.77 dB	

2 EUT Description

Applicant	Wuunet Technology Co., Ltd 9F, No. 364, Sec. 1, Nangang Rd., Nangang Dist., Taipei City 11579, Taiwan			
Manufacturer	Yongguan Electronic Technology (D.G.) Ltd. Mowu Village, Wanjiang District, Dongguan City, Guangdong Province, P.R. China			
Product Type	Kalay Home Smart Light Camera 1080P			
Model Number	WB102U			
FCC ID	2AF8P-WB102U			
Operate Freq. Band	Frequency Range (MHz)	Modulation	Channel Bandwidth	Data Rate 400 / 800 GI (ns)
IEEE 802.11b	2412 ~ 2462	DSSS	20 MHz	Up to 11 Mbps
IEEE 802.11g	2412 ~ 2462	OFDM	20 MHz	Up to 54 Mbps
IEEE 802.11n 2.4 GHz 20 MHz	2412 ~ 2462	OFDM	20 MHz	Up to 72.2 Mbps
IEEE 802.11n 2.4 GHz 40 MHz	2422 ~ 2452	OFDM	40 MHz	Up to 150 Mbps
Antenna information	Type		Max. Gain (dBi)	
	FPC Antenna		2.546	
Antenna Delivery	See section 3.1			
Operate Temp. Range	0 ~ +40 °C			

Frequency Band	Max. RF Output Power (W)
IEEE 802.11b	0.027
IEEE 802.11g	0.026
IEEE 802.11n 2.4 GHz 20 MHz	0.026
IEEE 802.11n 2.4 GHz 40 MHz	0.023

3 Test Methodology

3.1. Mode of Operation

Decision of Test ATL has verified the construction and function in typical operation. All the test modes were carried out with the EUT in normal operation, which was shown in this test report and defined as:

Test Mode
Mode 1: Transmit mode
Mode 2: IEEE 802.11b Continuous TX mode
Mode 3: IEEE 802.11g Continuous TX mode
Mode 4: IEEE 802.11n 2.4 GHz 20 MHz Continuous TX mode
Mode 5: IEEE 802.11n 2.4 GHz 40 MHz Continuous TX mode

Software used to control the EUT for staying in continuous transmitting mode was programmed.

After verification, all tests were carried out with the worst case test modes as shown below except radiated spurious emission below 1 GHz and power line conducted emissions below 30 MHz, which worst case was in TX mode only. By preliminary testing and verifying three axis (X, Y and Z) position of EUT transmitted status, it was found that "X axis" position was the worst, then the final test was executed the worst condition and test data were recorded in this report.

Test Mode	ANT-0
Mode 2	V
Mode 3	V
Mode 4	V
Mode 5	V

Test Mode	Antenna Delivery	Data Rate	Test Channel
Mode 2	1TX	1 M	1, 6, 11
Mode 3	1TX	6 M	1, 6, 11
Mode 4	1TX	6.5 M	1, 6, 11
Mode 5	1TX	13.5 M	3, 6, 9



Duty cycle

Test Mode	Frequency (MHz)	on time (ms)	on+off time (ms)	Duty cycle	Duty Factor (dB)	1/T Minimum VBW (kHz)
Mode 2	2412	6.960	6.960	1.000	0.000	0.010
Mode 3	2412	22.080	22.080	1.000	0.000	0.010
Mode 4	2412	28.360	28.360	1.000	0.000	0.010
Mode 5	2422	9.160	9.160	1.000	0.000	0.010

Duty Cycle Graphs

Mode 2: IEEE 802.11b Continuous TX mode



Mode 3: IEEE 802.11g Continuous TX mode



Mode 4: IEEE 802.11n 2.4 GHz 20 MHz Continuous TX mode

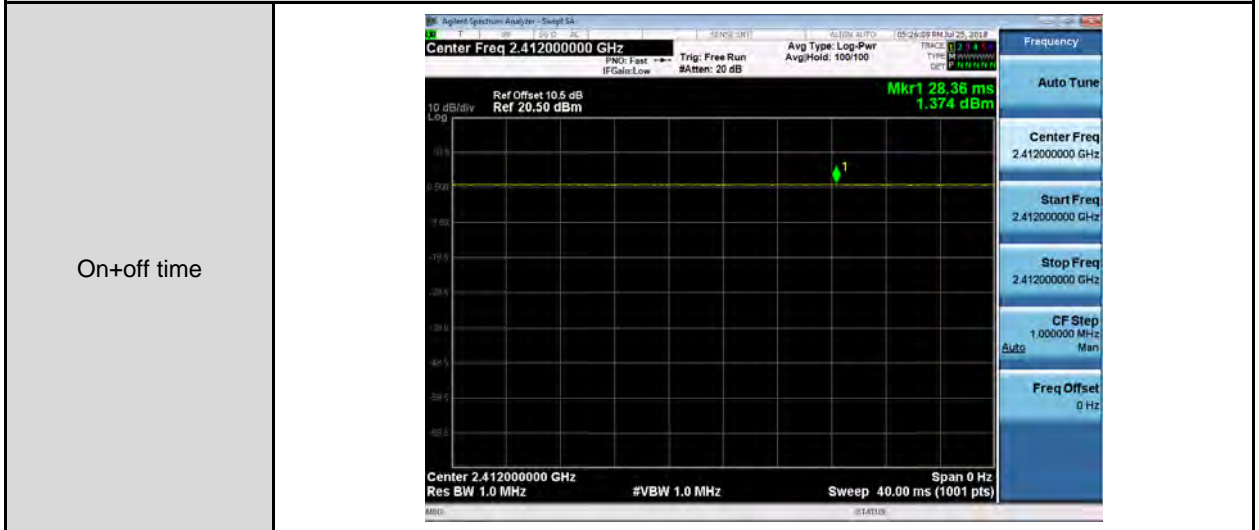

Mode 5: IEEE 802.11n 2.4 GHz 40 MHz Continuous TX mode





3.2. EUT Exercise Software

1.	Setup the EUT shown on "Configuration of Test System Details".
2.	Turn on the power of all equipment.
3.	Turn on TX function
4.	EUT run test program.

Measurement Software	
1	EZ-EMC Ver. ATL-03A1-1
2	EZ-EMC Ver ATL-ITC-3A1-1

3.3. Configuration of Test System Details

Conducted Emissions

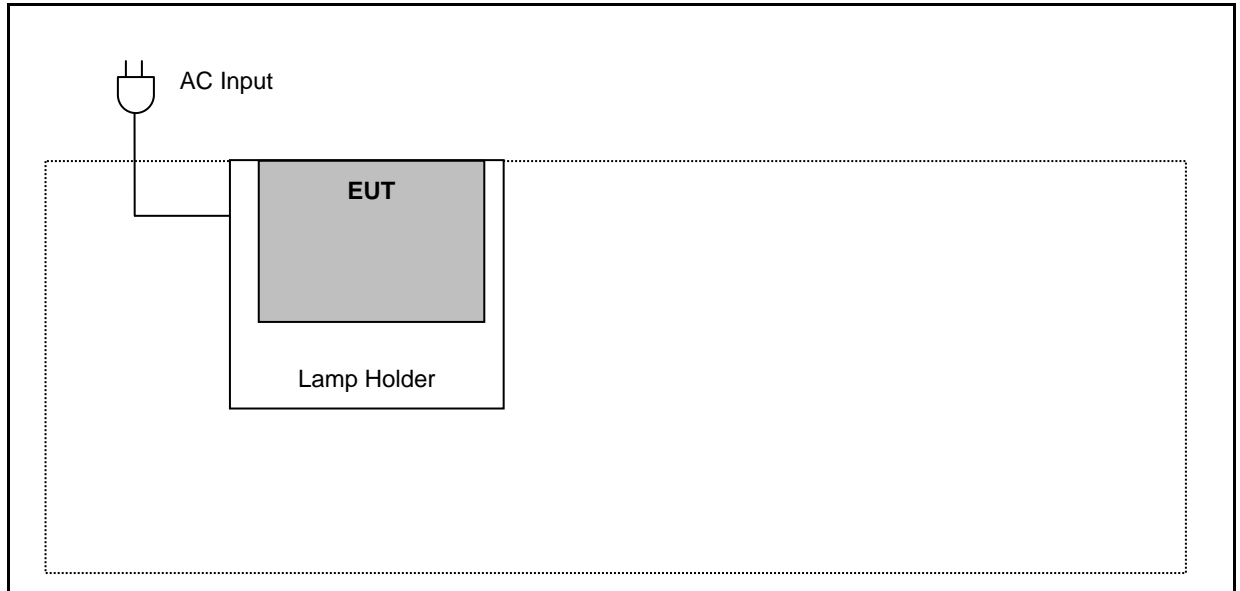

Radiated Emission

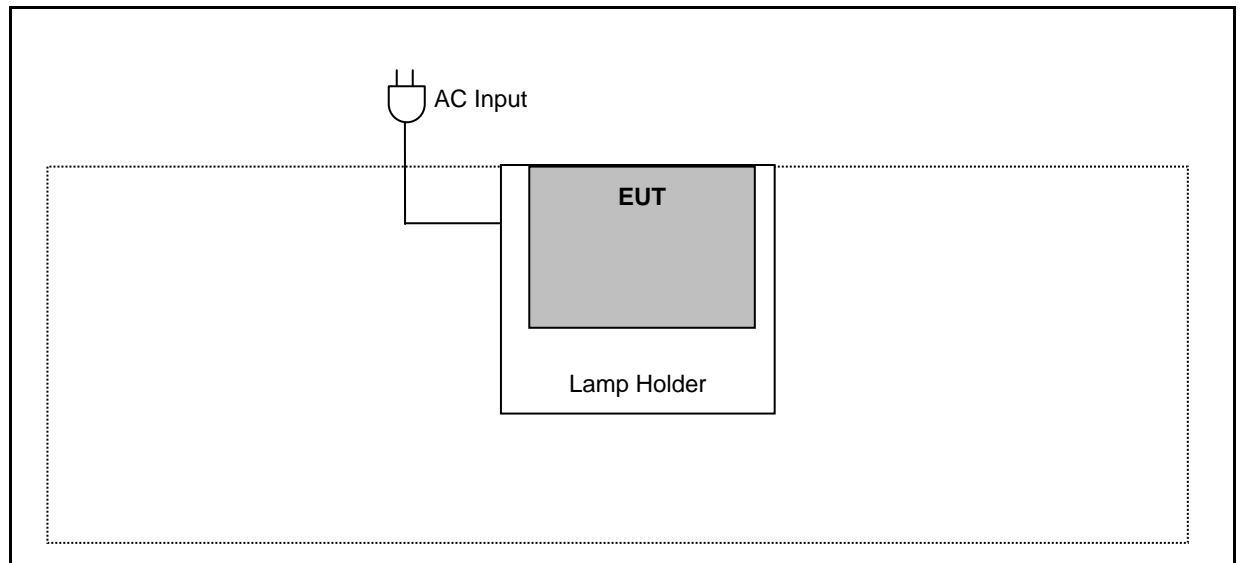



3.4. Test Instruments

For Conducted Emission
 Test Period: Jul. 26, 2018

Equipment	Manufacturer	Model Number	Serial Number	Cal. Date	Cal. Period
Test Receiver	R&S	ESR3	101923	09/19/2017	1 year
LISN	R&S	ENV216	101942	09/09/2017	1 year
LISN	R&S	ENV216	101943	09/19/2017	1 year
RF Cable	EMCI	EMCCFD400	433LFC	05/19/2018	1 year
Test Site	ATL	CE	CE	N.C.R.	-----

For Radiated Emissions
 Test Period: Jul. 26, 2018

Equipment	Manufacturer	Model Number	Serial Number	Cal. Date	Cal. Period
Preamplifier (10 kHz~3 GHz)	EMCI	EMC001330	980300	09/19/2017	1 year
Preamplifier (0.1 GHz~26.5 GHz)	EMCI	EMC012645SE	980318	09/19/2017	1 year
Bilog Antenna (30 MHz~1.4 GHz)	Schwarzbeck	VULB 9168	672	11/15/2017	1 year
Horn Antenna (1 GHz~18 GHz)	ETS	3117	00204949	11/16/2017	1 year
Horn Antenna (18 GHz~26.5 GHz)	ETS	3160-09	00202549	11/16/2017	1 year
Receiver (3 Hz~26.5 GHz)	Keysight	N9038A	MY51210179	09/19/2017	1 year
Spectrum Analyzer (3 Hz~43 GHz)	Keysight	N9030A	MY55410268	09/19/2017	1 year
Cable (30 MHz~1 GHz)	EMCI	N/A	1066LFC	09/19/2017	1 year
Cable (1 GHz~26.5 GHz)	EMCI	N/A	160719	09/19/2017	1 year
Cable (1 GHz~26.5 GHz)	EMCI	N/A	160324	09/19/2017	1 year
Cable (1 GHz~26.5 GHz)	EMCI	N/A	160322	09/19/2017	1 year
Loop Antenna	EMCI	LPA600	272	02/07/2018	1 year
Test Site	OuHeng	MFAC3M	RE-026	03/15/2018	1 year

Note: N.C.R. = No Calibration Request.



For Conducted

Test Period: Jul. 25 ~ Sep. 13, 2018

Equipment	Manufacturer	Model Number	Serial Number	Cal. Date	Cal. Period
Power Sensor	Anritsu	U2021XA	SG54130003	09/19/2017	1 year
Power Sensor	Anritsu	U2021XA	SG54130004	09/19/2017	1 year
Spectrum Analyzer (10 Hz~26.5 GHz)	Agilent	N9020A	MY53420615	09/19/2017	1 year
Programmable temp &humi chamber	ETAI	9712A	647	09/19/2017	1 year
Test Site	ATL	RF	RF	N.C.R.	-----

Note: N.C.R. = No Calibration Request.

3.5. Test Site Environment

Items	Required (IEC 60068-1)	Actual
Temperature (°C)	15-35	26
Humidity (%RH)	25-75	60
Barometric pressure (mbar)	860-1060	950

4 Measurement Procedure

4.1. AC Power Line Conducted Emission Measurement

■ Limit

Frequency (MHz)	Quasi-peak	Average
0.15 - 0.5	66 to 56	56 to 46
0.50 - 5.0	56	46
5.0 - 30.0	60	50

■ Test Setup

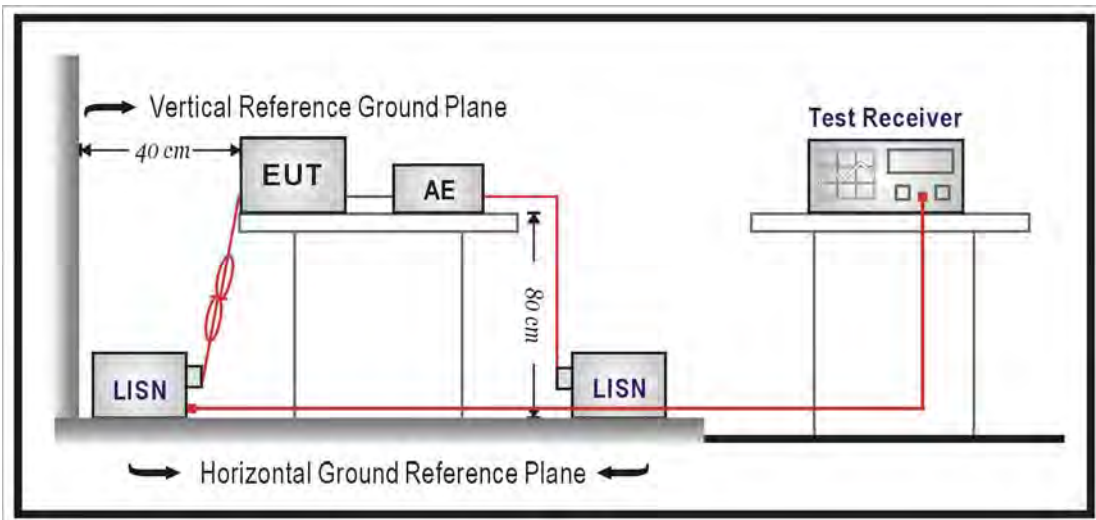

■ Test Procedure

The EUT and simulators are connected to the main power through a line impedance stabilization network (L.I.S.N.). This provides a $50 \Omega // 50 \mu\text{H}$ coupling impedance for the measuring equipment. The peripheral devices are also connected to the main power through a LISN that provides a $50 \Omega // 50 \mu\text{H}$ coupling impedance with 50ohm termination.

Tabletop device shall be placed on a non-conducting platform, of nominal size 1 m by 1.5 m, raised 80 cm above the reference ground plane. The wall of screened room shall be located 40 cm to the rear of the EUT. Other surfaces of tabletop or floor standing EUT shall be at least 80 cm from any other ground conducting surface including one or more LISNs. For floor-standing device shall be placed under the EUT with a 12 mm insulating material.

Conducted emissions were investigated over the frequency range from 0.15 MHz to 30 MHz using a resolution bandwidth of 9 kHz. The equipment under test (EUT) shall be meet the limits in section 4.1, as applicable, including the average limit and the quasi-peak limit when using respectively, an average detector and quasi-peak detector measured in accordance with the methods described of related standard. When all of peak value were complied with quasi-peak and average limit from 150 kHz to 30 MHz then quasi-peak and average measurement was unnecessary.

The AMN shall be placed 0.8 m from the boundary of the unit under test and bonded to a ground reference plane for AMNs mounted on top of the ground reference plane. This distance is between the closest points of the AMN and the EUT. All other units of the EUT and associated equipment shall be at least 0.8 m from the AMN. If the mains power cable is longer than 1 m then the cable shall be folded back and forth at the centre of the lead to form a bundle no longer than 0.4 m. All of interconnecting cables that hang closer than 40 cm to the ground plane shall be folded back and forth in the center forming a bundle 30 cm to 40 cm long. All of EUT and AE shall be separate place more than 0.1 m. All 50 Ω ports of the LISN shall be resistively terminated into 50 Ω loads when not connected to the measuring instrument.

If the reading of the measuring receiver shows fluctuations close to the limit, the reading shall be observed for at least 15 s at each measurement frequency; the higher reading shall be recorded with the exception of any brief isolated high reading which shall be ignored.

4.2. Radiated Emission Measurement

■ Limit

According to §15.209(a), except as provided elsewhere in this subpart, the emissions from an intentional radiator shall not exceed the field strength levels specified in the following table:

Frequency (MHz)	Field Strength ($\mu\text{V}/\text{m}$ at meter)	Measurement Distance (meters)
0.009 – 0.490	2400 / F (kHz)	300
0.490 – 1.705	24000 / F (kHz)	30
1.705 – 30.0	30	30
30 - 88	100**	3
88-216	150**	3
216-960	200**	3
Above 960	500	3

** Except as provided in paragraph (g), fundamental emissions from intentional radiators operating under this Section shall not be located in the frequency bands 54-72 MHz, 76-88 MHz, 174-216 MHz or 470-806 MHz. However, operation within these frequency bands is permitted under other sections of this Part, e.g., Sections 15.231 and 15.241.

■ Setup

9 kHz ~ 30 MHz

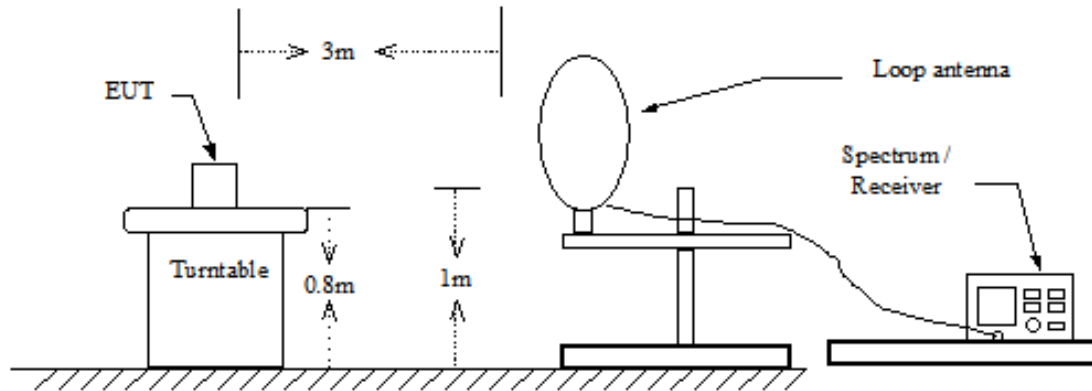

Below 1 GHz

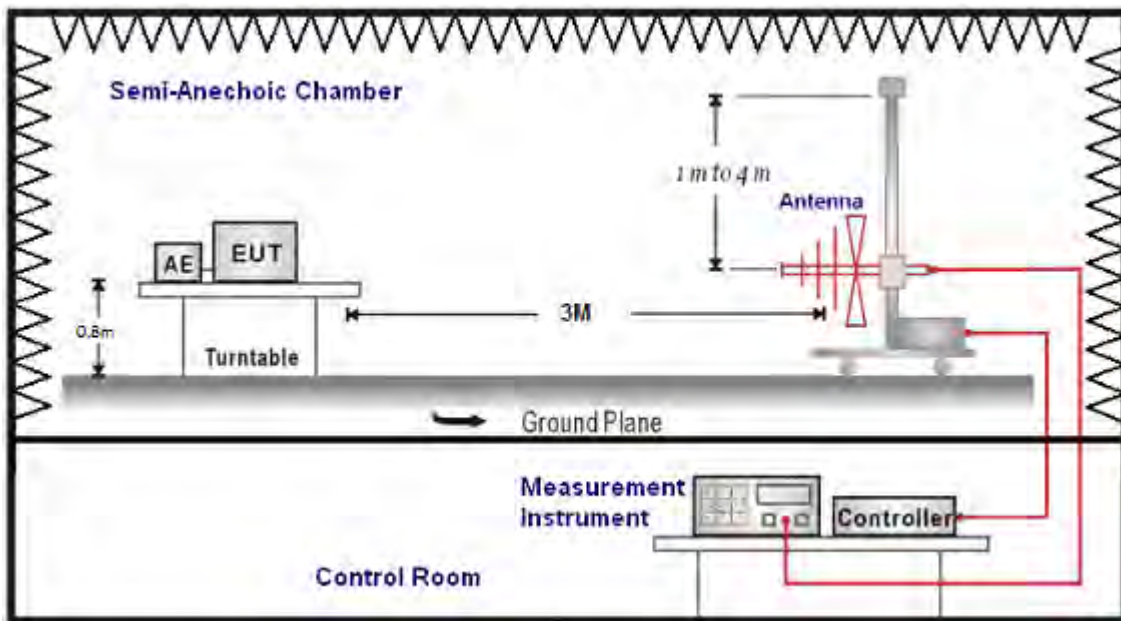

Above 1 GHz

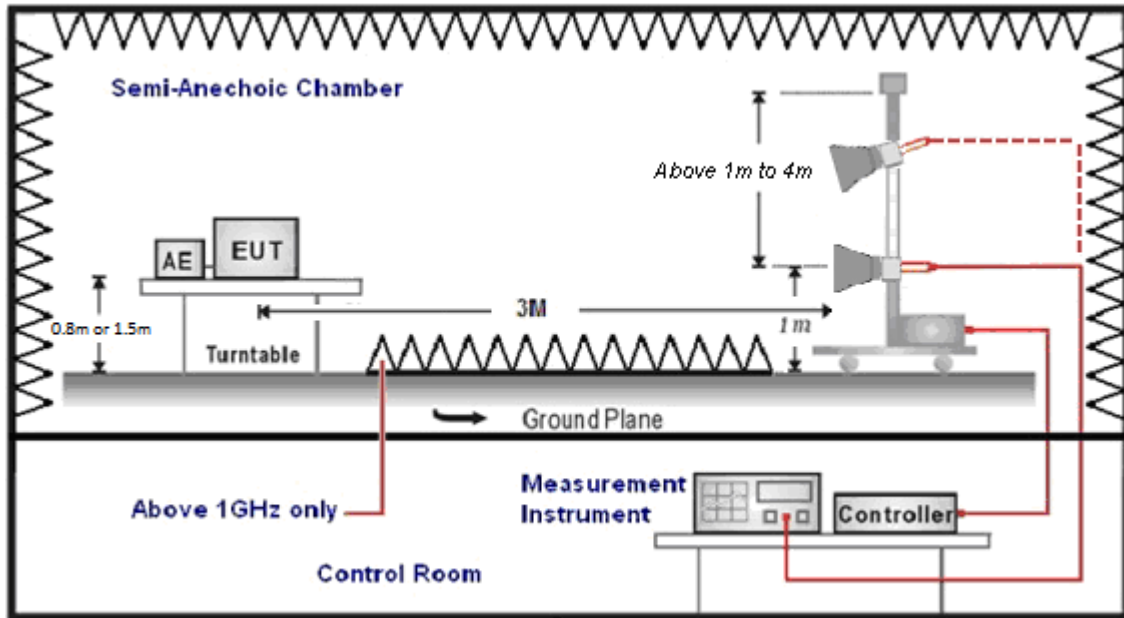



■ Test Procedure

Final radiation measurements were made on a three-meter, Semi Anechoic Chamber. The EUT system was placed on a nonconductive turntable which is 0.8 or 1.5 meters height, top surface 1.0 x 1.5 meter. The spectrum was examined from 250 MHz to 2.5 GHz in order to cover the whole spectrum below 10th harmonic which could generate from the EUT. During the test, EUT was set to transmit continuously & Measurements spectrum range from 9 kHz to 26.5 GHz is investigated.

For measurements below 1 GHz the resolution bandwidth is set to 100 kHz for peak detection measurements or 120 kHz for quasi-peak detection measurements. Peak detection is used unless otherwise noted as quasi-peak.

For measurements above 1 GHz the resolution bandwidth is set to 1 MHz, and then the video bandwidth is set to 1 MHz for peak measurements and 10 Hz for average measurements when Duty cycle >0.98 / $1/T$ for average measurements when Duty cycle <0.98 . A nonconductive material surrounded the EUT to supporting the EUT for standing on three orthogonal planes. At each condition, the EUT was rotated 360 degrees, and the antenna was raised and lowered from one to four meters to find the maximum emission levels. Measurements were taken using both horizontal and vertical antenna polarization.

SCHWARZBECK MESS-ELEKTRONIK Biconilog Antenna at 3 Meter and the SCHWARZBECK Double Ridged Guide Antenna was used in frequencies 1 –26.5 GHz at a distance of 3 meter. The antenna at an angle toward the source of the emission. All test results were extrapolated to equivalent signal at 3 meters utilizing an inverse linear distance extrapolation Factor (20 dB/decade).

For testing above 1 GHz, the emission level of the EUT in peak mode was 20 dB lower than average limit (that means the emission level in peak mode also complies with the limit in average mode), then testing will be stopped and peak values of EUT will be reported, otherwise, the emissions will be measured in average mode again and reported.

Appropriate preamplifiers were used for improving sensitivity and precautions were taken to avoid overloading or desensitizing the spectrum analyzer. No post – detector video filters were used in the test.

The spectrum analyzer's 6 dB bandwidth was set to 1 MHz, and the analyzer was operated in the peak detection mode, for frequencies both below and up 1 GHz. The average levels were obtained by subtracting the duty cycle correction factor from the peak readings.

The following procedures were used to convert the emission levels measured in decibels referenced to 1 microvolt (dBuV) into field intensity in micro volts pre meter (uV/m).

The actual field intensity in decibels referenced to 1 microvolt in to field intensity in micro volts per meter (dBuV/m).



The actual field intensity in referenced to 1 microvolt per meter (dBuV/m) is determined by algebraically adding the measured reading in dBuV, the antenna factor (dB), and cable loss (dB) and Subtracting the gain of preamplifier (dB) is auto calculate in spectrum analyzer.

$$(1) \text{ Amplitude (dBuV/m) = FI (dBuV) +AF (dBuV) +CL (dBuV)-Gain (dB)}$$

FI= Reading of the field intensity.

AF= Antenna factor.

CL= Cable loss.

P.S Amplitude is auto calculate in spectrum analyzer.

$$(2) \text{ Actual Amplitude (dBuV/m) = Amplitude (dBuV)-Dis(dB)}$$

The FCC specified emission limits were calculated according the EUT operating frequency and by following linear interpolation equations:

(a) For fundamental frequency : Transmitter Output < +30 dBm

(b) For spurious frequency : Spurious emission limits = fundamental emission limit /10

Data of measurement within this frequency range without mark in the table above means the reading of emissions are attenuated more than 20 dB below the permissible limits or the field strength is too small to be measured.

4.3. Maximum Conducted Output Power Measurement

■ Limit

For systems using digital modulation in the 2400-2483.5 MHz, the limit for maximum output power is 30 dBm.

And According to 15.247 (b), if transmitting antennas of directional gain greater than 6 dBi are used, the power shall be reduced by the amount in dB that the directional gain of the antenna exceeds 6 dBi.

■ Test Setup

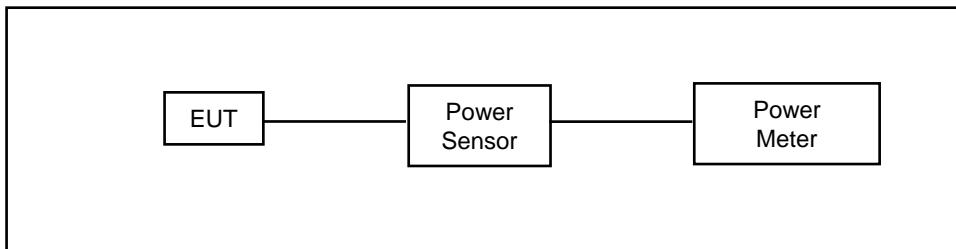

■ Test Procedure

The testing follows the Measurement Procedure of ANSI C63.10-2013 section 11.9.2.3 Method AVGPM.

The tests below are run with the EUT's transmitter set at high power in TX mode. The EUT is needed to force selection of output power level and channel number. While testing, EUT was set to transmit continuously. Remove the Subjective device's antenna and connect the RF output port to power sensor.

4.4. 6 dB RF Bandwidth Measurement

■ Limit

6 dB RF Bandwidth: Systems using digital modulation techniques may operate in the 2400–2483.5 MHz bands. The minimum 6 dB band-width shall be at least 500 kHz.

■ Test Setup

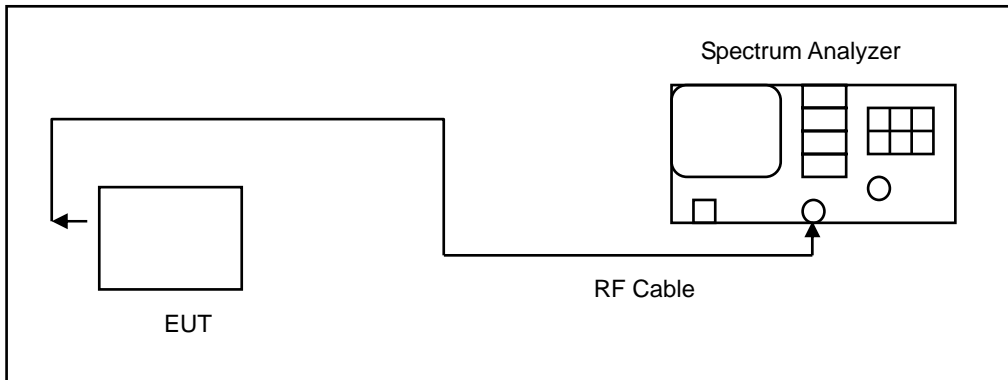

■ Test Procedure

The EUT tested to DTS test procedure of KDB 558074 D01 for compliance to FCC 47CFR 15.247 requirements.

6 dB RF Bandwidth: The antenna port of the EUT was connected to the input of a spectrum analyzer. Analyzer RBW was set to 100 kHz. For each RF output channel investigated, the spectrum analyzer center frequency was set to the channel carrier. A peak output reading was taken, a DISPLAY line was drawn 6 dB lower than peak level. The 6 dB bandwidth was determined from where the channel output spectrum intersected the display line.

The test was performed at 3 channels (Channel low, middle, high)

4.5. Maximum Power Spectral Density Measurement

■ Limit

For digitally modulated systems, the power spectral density conducted from the intentional radiator to the antenna shall not be greater than 8 dBm in any 3 kHz band during any time interval of continuous transmission.

■ Test Setup

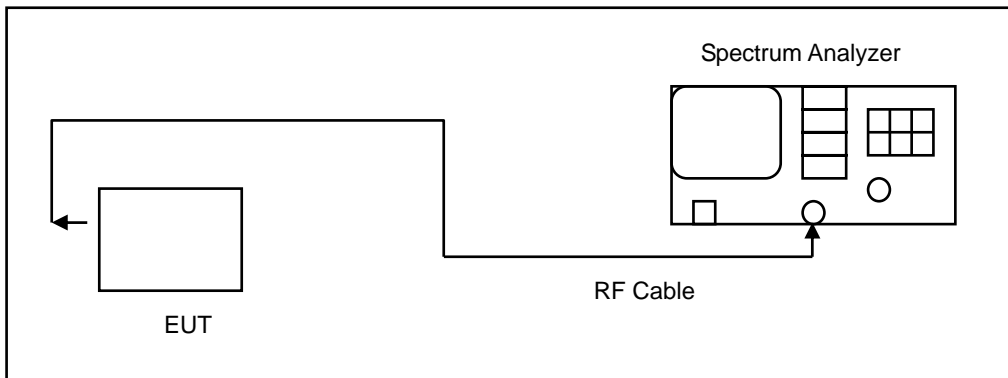

■ Test Procedure

The EUT tested to DTS test procedure of KDB 558074 D01 section 10.2 Method PKPSD for compliance to FCC 47CFR 15.247 requirements.

1. Set analyzer center frequency to DTS channel center frequency.
2. Set the span to 1.5 times the DTS bandwidth.
3. Set the RBW to: $3 \text{ kHz} \leq \text{RBW} \leq 100 \text{ kHz}$.
4. Set the VBW $\geq 3 \times \text{RBW}$.
5. Detector = peak.
6. Sweep time = auto couple.
7. Trace mode = max hold.
8. Allow trace to fully stabilize.
9. Use the peak marker function to determine the maximum amplitude level within the RBW.
10. If measured value exceeds limit, reduce RBW (no less than 3 kHz) and repeat.

4.6. Out of Band Conducted Emissions Measurement

■ **Limit**

In any 100 kHz bandwidth outside the frequency band in which the spread spectrum or digitally modulated intentional radiator is operating, the radio frequency power that is produced by the intentional radiator shall be at least 20 dB below that in the 100 kHz bandwidth within the band that contains the highest level of the desired power

■ **Test Setup**

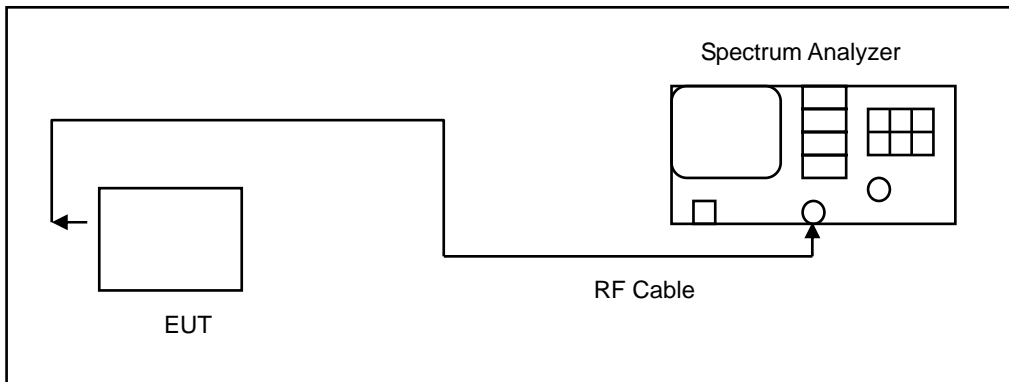

■ **Test Procedure**

In any 100 kHz bandwidth outside the EUT pass band, the RF power produced by the modulation products of the spreading sequence, the information sequence, and the carrier frequency shall be at least 20 dB below that of the maximum in-band 100 kHz emission, antenna output of the EUT was coupled directly to spectrum analyzer; if an external attenuator and/or cable was used, these losses are compensated for with the analyzer OFFSET function.

All other types of emissions from the EUT shall meet the general limits for radiated frequencies outside the pass band.

The test was performed at 3 channels.



4.7. Antenna Measurement

■ Limit

For intentional device, according to 15.203, an intentional radiator shall be designed to ensure that no antenna other than that furnished by the responsible party shall be used with the device.

And According to 15.247 (b), if transmitting antennas of directional gain greater than 6 dBi are used, the power shall be reduced by the amount in dB that the directional gain of the antenna exceeds 6 dBi.

■ Antenna Description

See section 2 – antenna information.



5 Test Results

Annex A. Conducted Emission

Standard:	FCC Part 15.247	Line:	L1
Test Mode:	Mode 1	Power:	AC 120 V/60 Hz
		Temp.(°C)/Hum.(%RH):	26(°C)/60% RH
Description:			

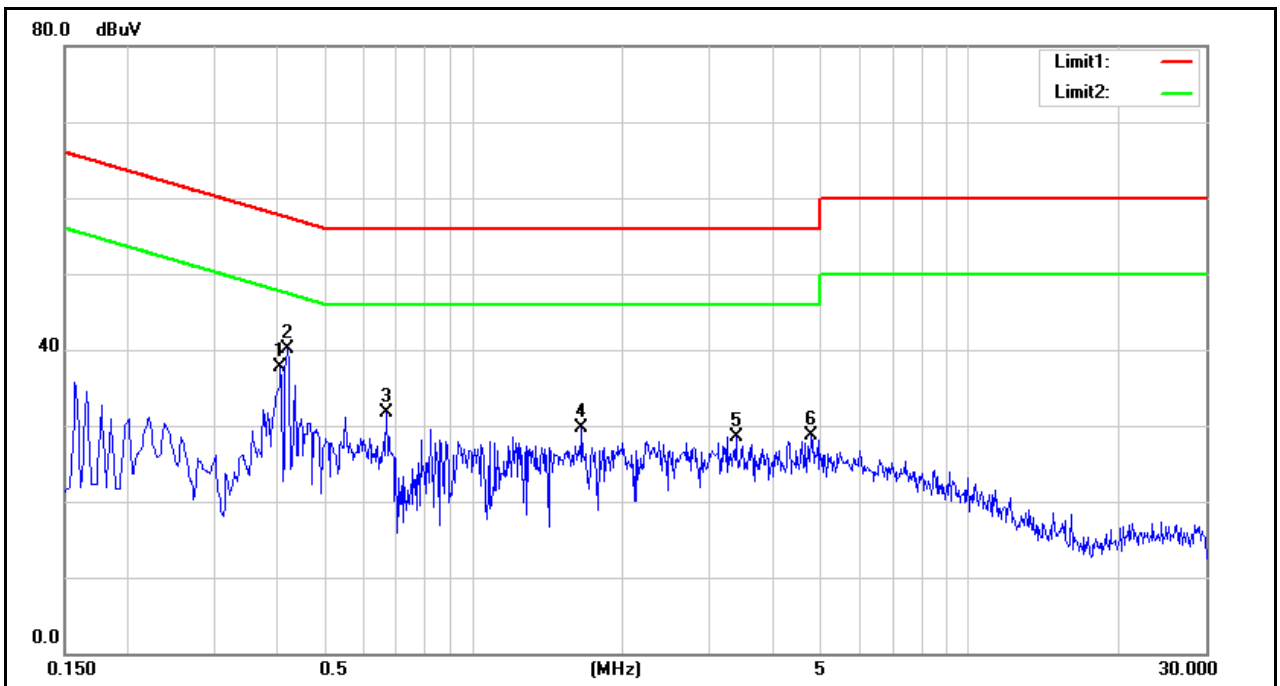

No.	Frequency (MHz)	QP reading (dBuV)	AVG reading (dBuV)	Correction factor (dB)	QP result (dBuV)	AVG result (dBuV)	QP limit (dBuV)	AVG limit (dBuV)	QP margin (dB)	AVG margin (dB)	Remark
1	0.4100	25.53	20.30	9.68	35.21	29.98	57.65	47.65	-22.44	-17.67	Pass
2	0.4220	29.29	20.56	9.68	38.97	30.24	57.41	47.41	-18.44	-17.17	Pass
3	0.6700	14.85	7.47	9.69	24.54	17.16	56.00	46.00	-31.46	-28.84	Pass
4	1.6580	15.30	7.86	9.73	25.03	17.59	56.00	46.00	-30.97	-28.41	Pass
5	3.3900	12.83	7.68	9.80	22.63	17.48	56.00	46.00	-33.37	-28.52	Pass
6	4.8060	12.60	6.26	9.86	22.46	16.12	56.00	46.00	-33.54	-29.88	Pass

Note: 1. Result (dBuV/m) = Correct Factor (dB/m) + Reading(dBuV).
 2. Correction factor (dB) = Cable loss (dB) + L.I.S.N. factor (dB).



Standard:	FCC Part 15.247	Line:	N
Test Mode:	Mode 1	Power:	AC 120 V/60 Hz
		Temp.(°C)/Hum.(%RH):	26(°C)/60% RH
Description:			

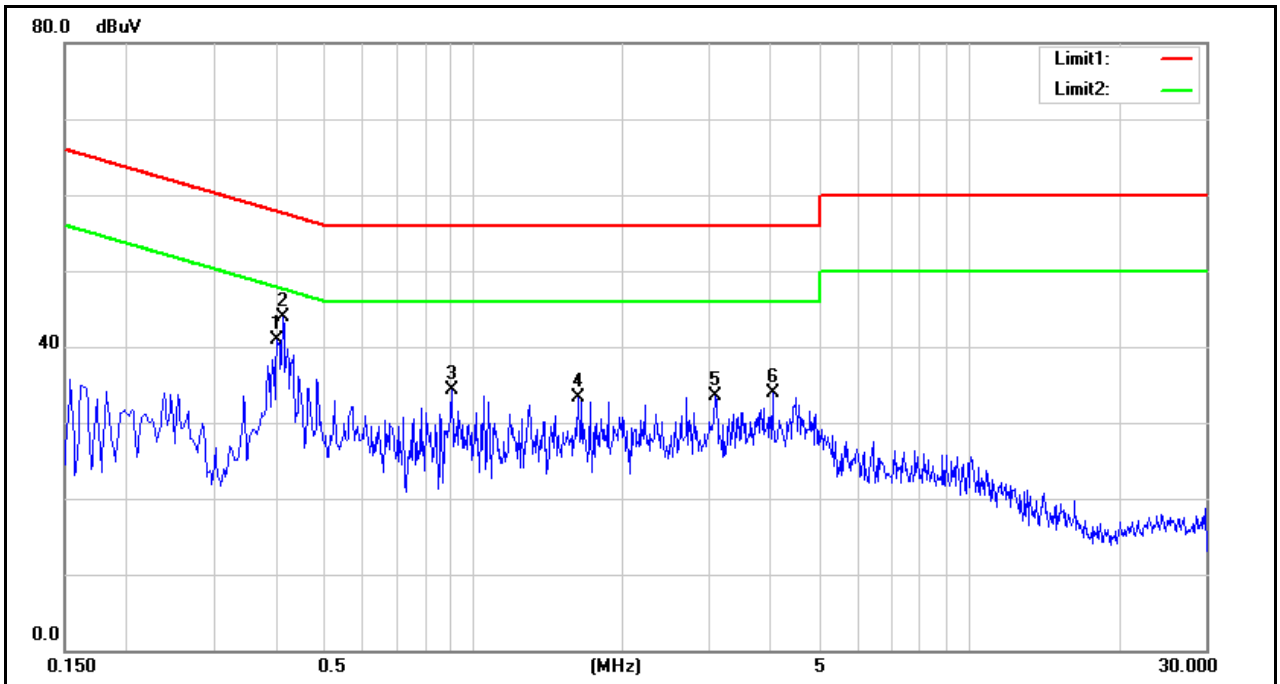

No.	Frequency (MHz)	QP reading (dBuV)	AVG reading (dBuV)	Correction factor (dB)	QP result (dBuV)	AVG result (dBuV)	QP limit (dBuV)	AVG limit (dBuV)	QP margin (dB)	AVG margin (dB)	Remark
1	0.4020	25.45	18.36	9.70	35.15	28.06	57.81	47.81	-22.66	-19.75	Pass
2	0.4140	29.83	25.42	9.70	39.53	35.12	57.57	47.57	-18.04	-12.45	Pass
3	0.9060	15.86	10.25	9.73	25.59	19.98	56.00	46.00	-30.41	-26.02	Pass
4	1.6340	17.62	11.44	9.75	27.37	21.19	56.00	46.00	-28.63	-24.81	Pass
5	3.0900	16.16	10.29	9.81	25.97	20.10	56.00	46.00	-30.03	-25.90	Pass
6	4.0220	15.26	9.72	9.85	25.11	19.57	56.00	46.00	-30.89	-26.43	Pass

Note: 1. Result (dBuV/m) = Correct Factor (dB/m) + Reading(dBuV).
 2. Correction factor (dB) = Cable loss (dB) + L.I.S.N. factor (dB).

Annex B. Conducted Test Results

Maximum Conducted Output Power Measurement

Test Mode	Data Rate (Mbps)	Frequency (MHz)	Average Output Power		Peak Output Power		
			Measurement Results		Measurement Results		Limit
			dBm	W	dBm	W	dBm
Mode 2	1	2412	11.25	0.013	13.95	0.025	< 30
		2437	12.00	0.016	14.37	0.027	< 30
		2462	11.49	0.014	13.92	0.025	< 30
	2	2437	11.94	0.016	14.26	0.027	< 30
	5.5	2437	11.90	0.015	14.21	0.026	< 30
	11	2437	11.87	0.015	14.17	0.026	< 30
Mode 3	6	2412	7.63	0.006	14.22	0.026	< 30
		2437	7.57	0.006	14.09	0.026	< 30
		2462	7.46	0.006	14.06	0.025	< 30
	9	2437	7.55	0.006	14.06	0.025	< 30
	12	2437	7.45	0.006	13.98	0.025	< 30
	18	2437	7.37	0.005	13.88	0.024	< 30
	24	2437	7.36	0.005	13.87	0.024	< 30
	36	2437	7.35	0.005	13.86	0.024	< 30
	48	2437	7.26	0.005	13.78	0.024	< 30
	54	2437	7.25	0.005	13.77	0.024	< 30

Note: The relevant measured result has the offset with cable loss already.



Test Mode	Data Rate (Mbps)	Frequency (MHz)	Average Output Power		Peak Output Power		
			Measurement Results		Measurement Results		Limit
			dBm	W	dBm	W	dBm
Mode 4	6.5	2412	7.10	0.005	13.88	0.024	< 30
		2437	7.23	0.005	14.09	0.026	< 30
		2462	7.41	0.006	14.18	0.026	< 30
	14.4	2437	7.18	0.005	13.99	0.025	< 30
	21.7	2437	7.13	0.005	13.98	0.025	< 30
	28.9	2437	7.11	0.005	13.89	0.024	< 30
	43.3	2437	7.03	0.005	13.86	0.024	< 30
	57.8	2437	7.02	0.005	13.84	0.024	< 30
	65	2437	7.01	0.005	13.78	0.024	< 30
	72.2	2437	6.94	0.005	13.77	0.024	< 30
Mode 5	13.5	2422	6.09	0.004	13.08	0.020	< 30
		2437	6.62	0.005	13.55	0.023	< 30
		2452	4.78	0.003	11.80	0.015	< 30
	30	2437	6.58	0.005	13.48	0.022	< 30
	45	2437	6.52	0.004	13.44	0.022	< 30
	60	2437	6.50	0.004	13.41	0.022	< 30
	90	2437	6.42	0.004	13.39	0.022	< 30
	120	2437	6.40	0.004	13.34	0.022	< 30
	135	2437	6.37	0.004	13.33	0.022	< 30
	150	2437	6.34	0.004	13.31	0.021	< 30

Note: The relevant measured result has the offset with cable loss already.



6 dB RF Bandwidth Measurement

Test Mode	Frequency (MHz)	Measurement (kHz)	Limit (kHz)
Mode 2	2412	10090	> 500
	2437	10080	> 500
	2462	10090	> 500
Mode 3	2412	16590	> 500
	2437	16590	> 500
	2462	16600	> 500
Mode 4	2412	17810	> 500
	2437	17800	> 500
	2462	17800	> 500
Mode 5	2422	36430	> 500
	2437	36410	> 500
	2452	36420	> 500



■ Test Graphs

Mode 2: IEEE 802.11b Continuous TX mode

2412 MHz



2437 MHz



2462 MHz





Mode 3: IEEE 802.11g Continuous TX mode

2412 MHz



2437 MHz



2462 MHz



Mode 4: IEEE 802.11n 2.4 GHz 20 MHz Continuous TX mode

2412 MHz



2437 MHz



2462 MHz



Mode 5: IEEE 802.11n 2.4 GHz 40 MHz Continuous TX mode

<p>2422 MHz</p>	<p>Center Freq 2.42200000 GHz</p> <p>Center Freq: 2.422000000 GHz Trig: Free Run #Attenu: 20 dB Radio Std: None Radio Device: BTS</p> <p>Ref 10.00 dBm</p> <p>Center 2.422 GHz #Res BW 100 kHz #VBW 300 kHz Span 50 MHz Sweep 4.8 ms</p> <table border="1"> <tr> <td>Occupied Bandwidth</td> <td>Total Power</td> <td>13.1 dBm</td> </tr> <tr> <td>35.944 MHz</td> <td></td> <td></td> </tr> <tr> <td>Transmit Freq Error</td> <td>OBW Power</td> <td>99.00 %</td> </tr> <tr> <td>39.824 kHz</td> <td></td> <td></td> </tr> <tr> <td>x dB Bandwidth</td> <td>x dB</td> <td>-6.00 dB</td> </tr> <tr> <td>36.43 MHz</td> <td></td> <td></td> </tr> </table>	Occupied Bandwidth	Total Power	13.1 dBm	35.944 MHz			Transmit Freq Error	OBW Power	99.00 %	39.824 kHz			x dB Bandwidth	x dB	-6.00 dB	36.43 MHz		
Occupied Bandwidth	Total Power	13.1 dBm																	
35.944 MHz																			
Transmit Freq Error	OBW Power	99.00 %																	
39.824 kHz																			
x dB Bandwidth	x dB	-6.00 dB																	
36.43 MHz																			
<p>2437 MHz</p>	<p>Center Freq 2.43700000 GHz</p> <p>Center Freq: 2.437000000 GHz Trig: Free Run #Attenu: 20 dB Radio Std: None Radio Device: BTS</p> <p>Ref 10.00 dBm</p> <p>Center 2.437 GHz #Res BW 100 kHz #VBW 300 kHz Span 50 MHz Sweep 4.8 ms</p> <table border="1"> <tr> <td>Occupied Bandwidth</td> <td>Total Power</td> <td>13.3 dBm</td> </tr> <tr> <td>35.930 MHz</td> <td></td> <td></td> </tr> <tr> <td>Transmit Freq Error</td> <td>OBW Power</td> <td>99.00 %</td> </tr> <tr> <td>39.462 kHz</td> <td></td> <td></td> </tr> <tr> <td>x dB Bandwidth</td> <td>x dB</td> <td>-6.00 dB</td> </tr> <tr> <td>36.41 MHz</td> <td></td> <td></td> </tr> </table>	Occupied Bandwidth	Total Power	13.3 dBm	35.930 MHz			Transmit Freq Error	OBW Power	99.00 %	39.462 kHz			x dB Bandwidth	x dB	-6.00 dB	36.41 MHz		
Occupied Bandwidth	Total Power	13.3 dBm																	
35.930 MHz																			
Transmit Freq Error	OBW Power	99.00 %																	
39.462 kHz																			
x dB Bandwidth	x dB	-6.00 dB																	
36.41 MHz																			
<p>2452 MHz</p>	<p>Center Freq 2.45200000 GHz</p> <p>Center Freq: 2.452000000 GHz Trig: Free Run #Attenu: 20 dB Radio Std: None Radio Device: BTS</p> <p>Ref 10.00 dBm</p> <p>Center 2.452 GHz #Res BW 100 kHz #VBW 300 kHz Span 50 MHz Sweep 4.8 ms</p> <table border="1"> <tr> <td>Occupied Bandwidth</td> <td>Total Power</td> <td>13.3 dBm</td> </tr> <tr> <td>35.950 MHz</td> <td></td> <td></td> </tr> <tr> <td>Transmit Freq Error</td> <td>OBW Power</td> <td>99.00 %</td> </tr> <tr> <td>31.103 kHz</td> <td></td> <td></td> </tr> <tr> <td>x dB Bandwidth</td> <td>x dB</td> <td>-6.00 dB</td> </tr> <tr> <td>36.42 MHz</td> <td></td> <td></td> </tr> </table>	Occupied Bandwidth	Total Power	13.3 dBm	35.950 MHz			Transmit Freq Error	OBW Power	99.00 %	31.103 kHz			x dB Bandwidth	x dB	-6.00 dB	36.42 MHz		
Occupied Bandwidth	Total Power	13.3 dBm																	
35.950 MHz																			
Transmit Freq Error	OBW Power	99.00 %																	
31.103 kHz																			
x dB Bandwidth	x dB	-6.00 dB																	
36.42 MHz																			





Maximum Power Spectral Density Measurement

Test Mode	Frequency (MHz)	Measurement (dBm/3 kHz)	Limit (dBm/3 kHz)
Mode 2	2412	-19.832	< 8
	2437	-19.102	< 8
	2462	-18.119	< 8
Mode 3	2412	-21.360	< 8
	2437	-21.719	< 8
	2462	-21.309	< 8
Mode 4	2412	-20.393	< 8
	2437	-19.971	< 8
	2462	-19.230	< 8
Mode 5	2422	-22.036	< 8
	2437	-21.554	< 8
	2452	-23.435	< 8

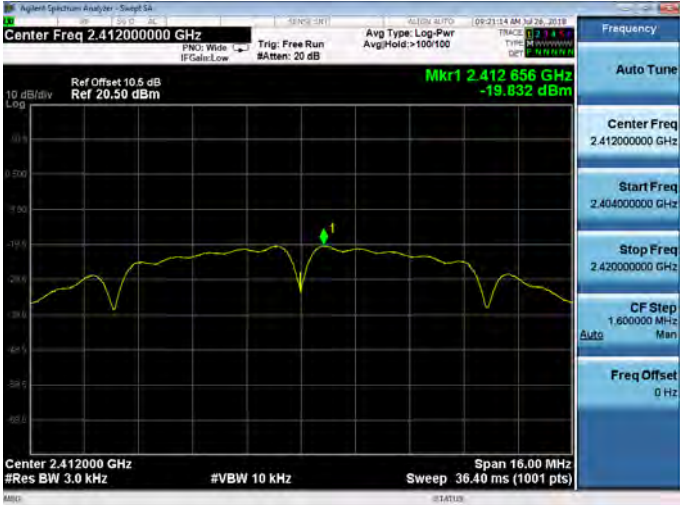
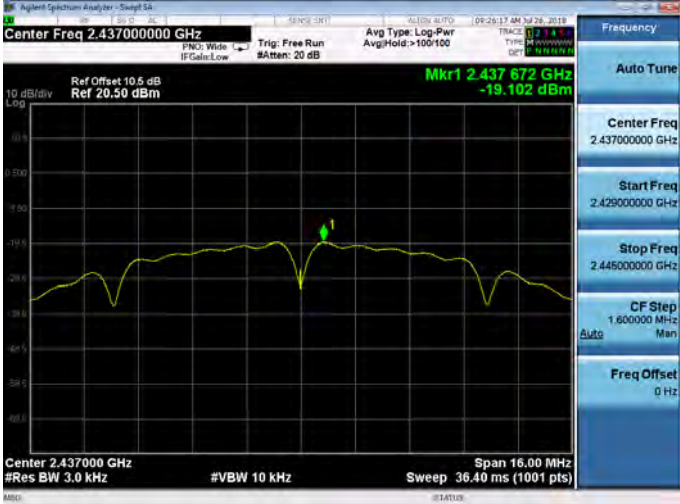

■ Test Graphs

Mode 2: IEEE 802.11b Continuous TX mode

2412 MHz	
2437 MHz	
2462 MHz	

Mode 3: IEEE 802.11g Continuous TX mode

2412 MHz

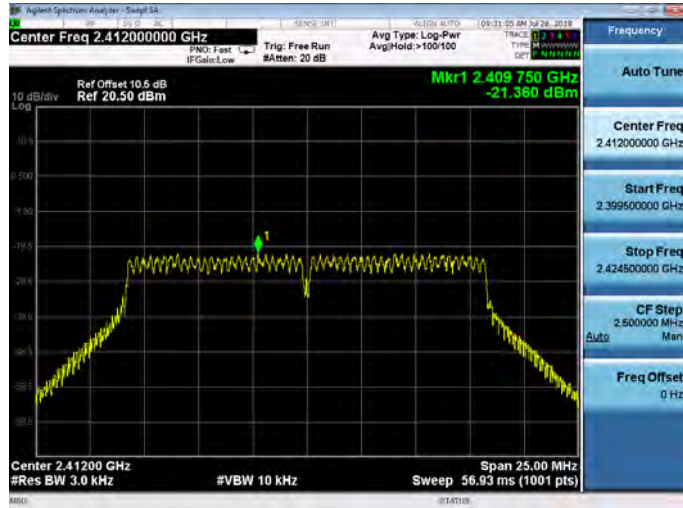

2437 MHz

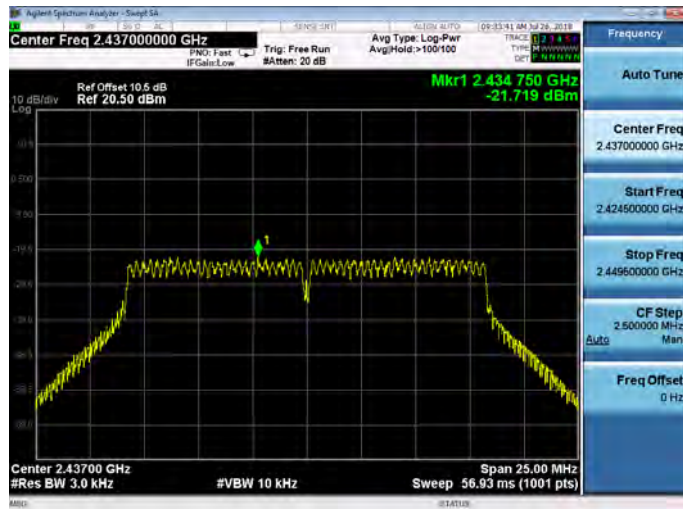

2462 MHz

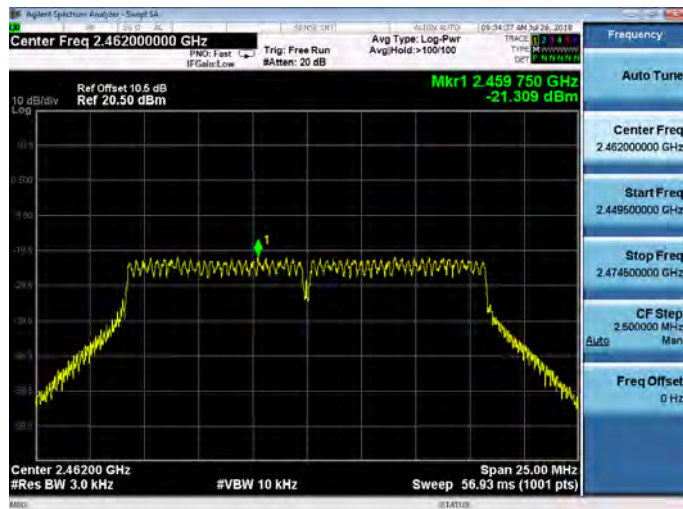



Mode 4: IEEE 802.11n 2.4 GHz 20 MHz Continuous TX mode

2412 MHz

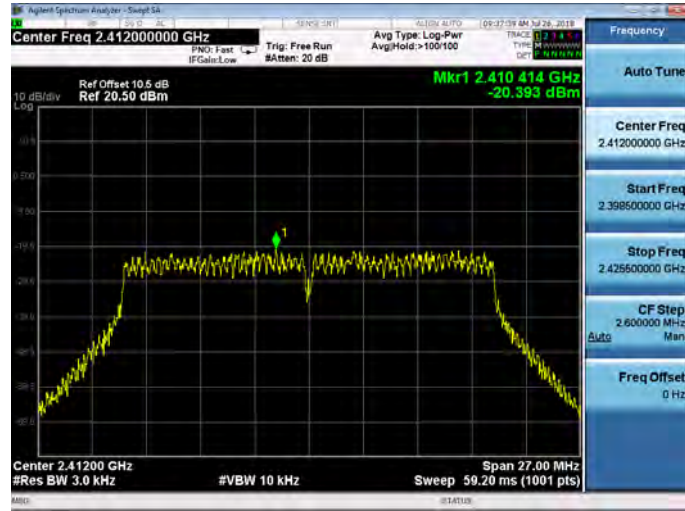

2437 MHz

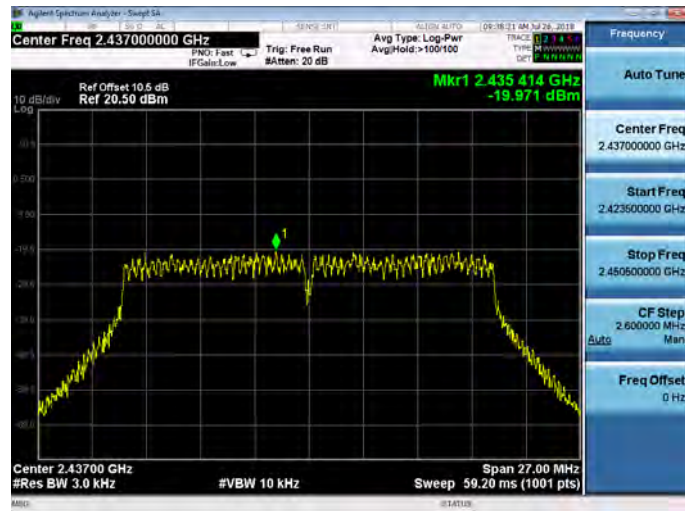

2462 MHz





Mode 5: IEEE 802.11n 2.4 GHz 40 MHz Continuous TX mode

2422 MHz

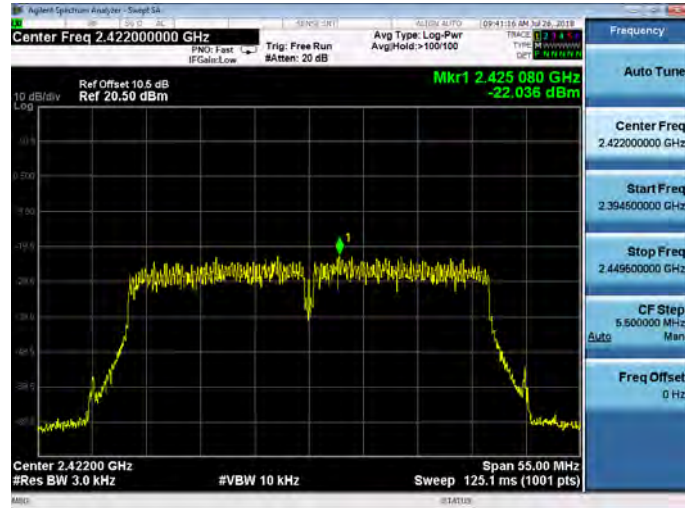

2437 MHz

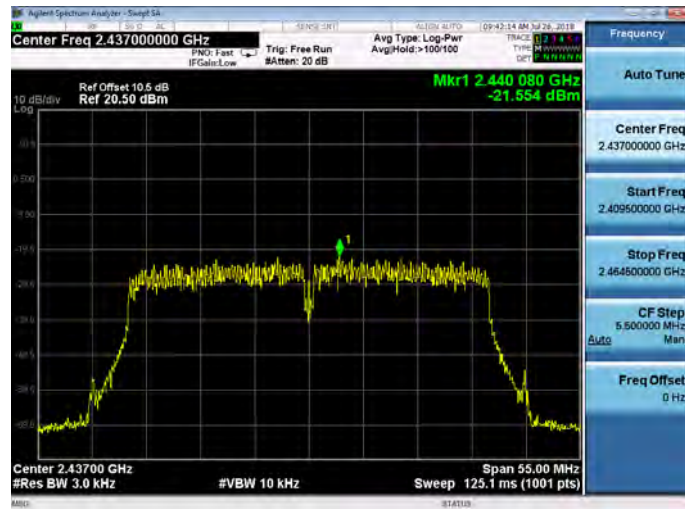

2452 MHz







Out of Band Conducted Emissions Measurement

■ Test Graphs

Reference level

Mode 2: IEEE 802.11b Continuous TX mode

2412 MHz	
2437 MHz	
2462 MHz	



Mode 3: IEEE 802.11g Continuous TX mode

2412 MHz

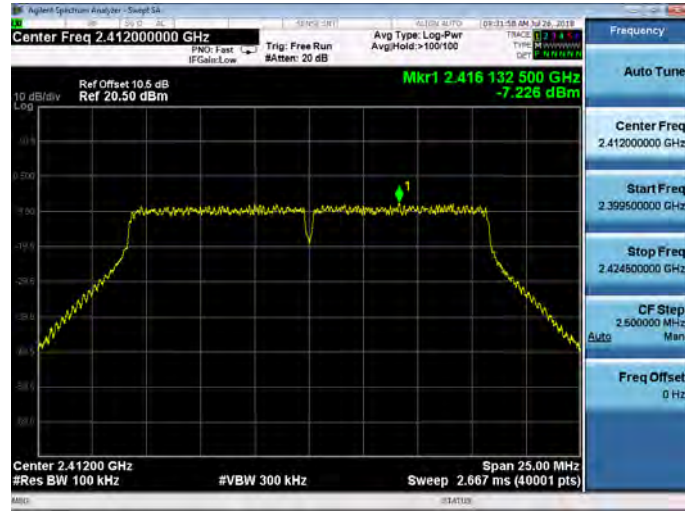

2437 MHz

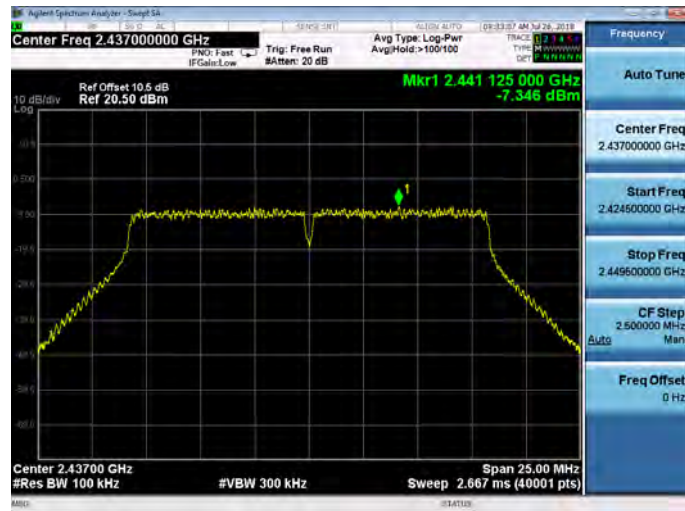

2462 MHz

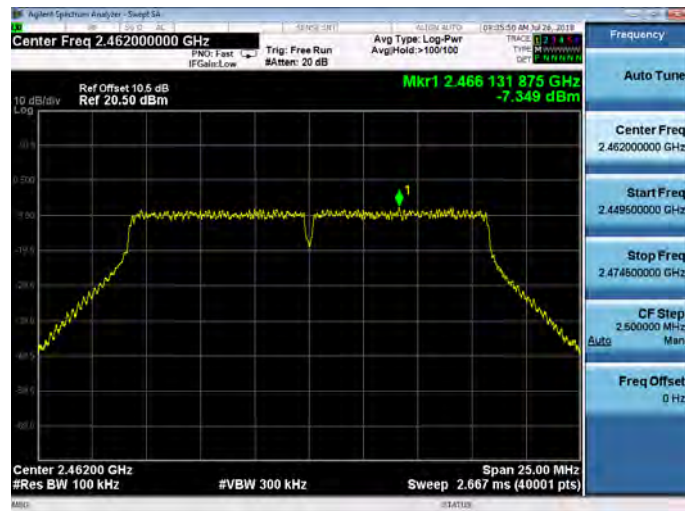



Mode 4: IEEE 802.11n 2.4 GHz 20 MHz Continuous TX mode

2412 MHz

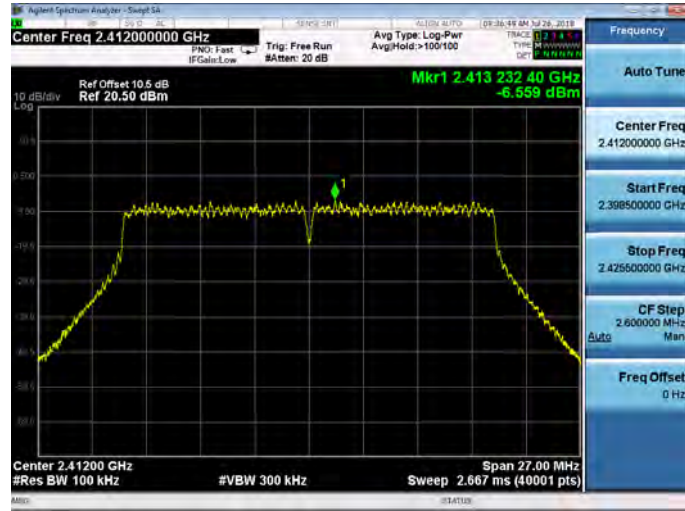

2437 MHz

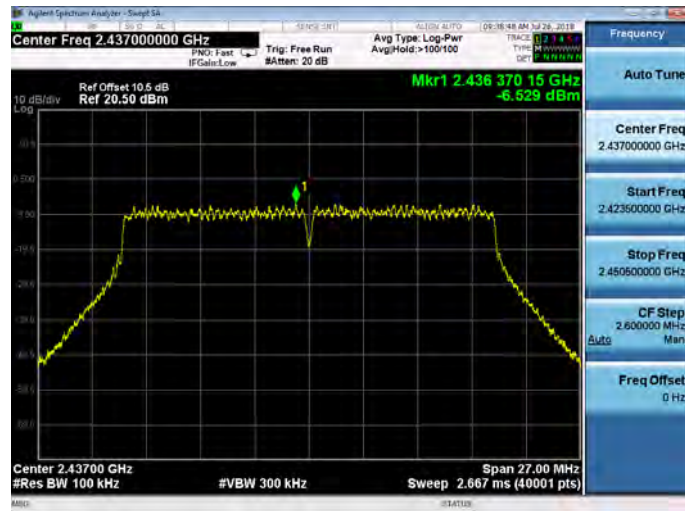

2462 MHz





Mode 5: IEEE 802.11n 2.4 GHz 40 MHz Continuous TX mode

2422 MHz

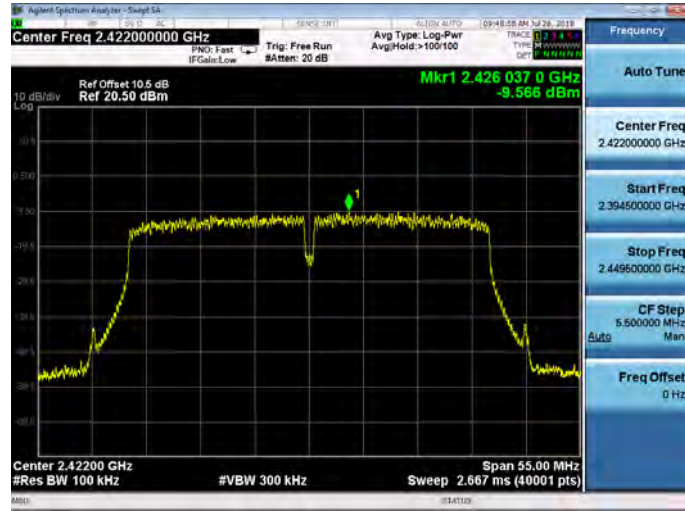

2437 MHz

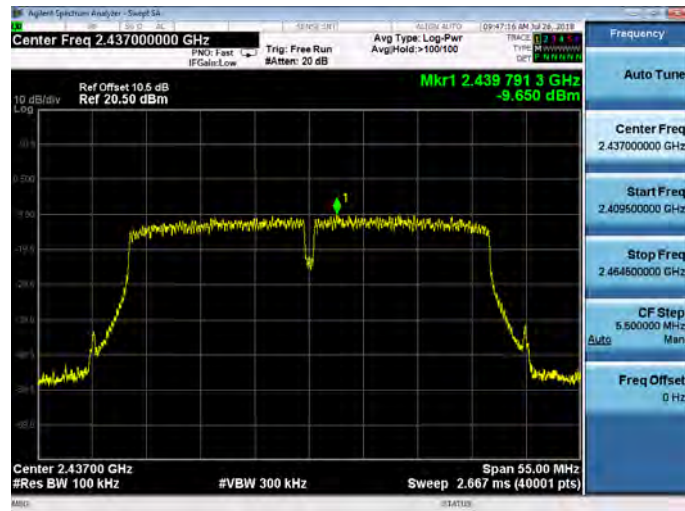

2452 MHz

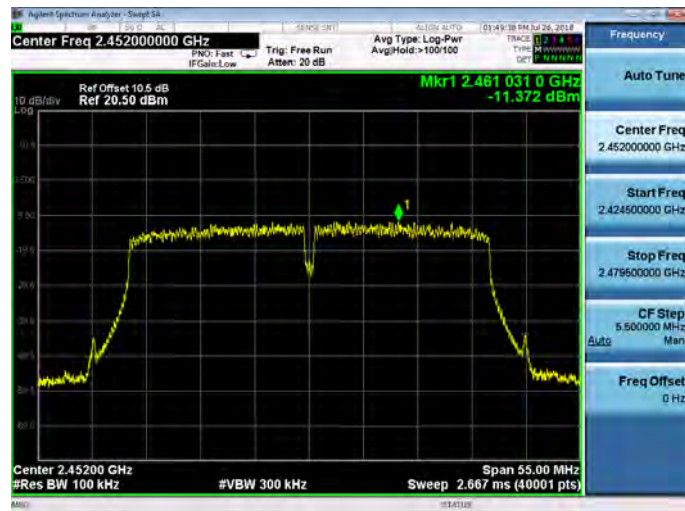



Out of Band Conducted Emissions

Mode 2: IEEE 802.11b Continuous TX mode

<p>2412 MHz</p>	<table border="1"><thead><tr><th>Mkr</th><th>Mode</th><th>Freq</th><th>Value</th></tr></thead><tbody><tr><td>1</td><td>1</td><td>2412.0 GHz</td><td>0.514 dBm</td></tr></tbody></table>	Mkr	Mode	Freq	Value	1	1	2412.0 GHz	0.514 dBm
Mkr	Mode	Freq	Value						
1	1	2412.0 GHz	0.514 dBm						
<p>2437 MHz</p>	<table border="1"><thead><tr><th>Mkr</th><th>Mode</th><th>Freq</th><th>Value</th></tr></thead><tbody><tr><td>1</td><td>1</td><td>2437.0 GHz</td><td>1.384 dBm</td></tr></tbody></table>	Mkr	Mode	Freq	Value	1	1	2437.0 GHz	1.384 dBm
Mkr	Mode	Freq	Value						
1	1	2437.0 GHz	1.384 dBm						
<p>2462 MHz</p>	<table border="1"><thead><tr><th>Mkr</th><th>Mode</th><th>Freq</th><th>Value</th></tr></thead><tbody><tr><td>1</td><td>1</td><td>2462.0 GHz</td><td>0.425 dBm</td></tr></tbody></table>	Mkr	Mode	Freq	Value	1	1	2462.0 GHz	0.425 dBm
Mkr	Mode	Freq	Value						
1	1	2462.0 GHz	0.425 dBm						

Mode 3: IEEE 802.11g Continuous TX mode

2412 MHz

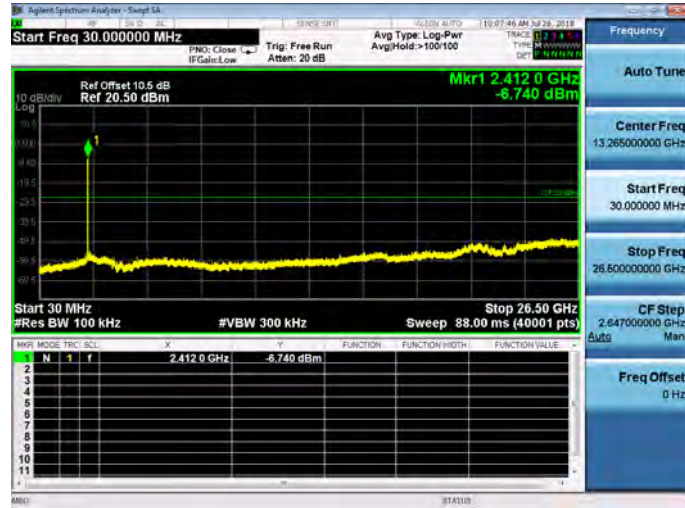

2437 MHz



2462 MHz



Mode 4: IEEE 802.11n 2.4 GHz 20 MHz Continuous TX mode

2412 MHz



2437 MHz



2462 MHz





Mode 5: IEEE 802.11n 2.4 GHz 40 MHz Continuous TX mode

2422 MHz



2437 MHz

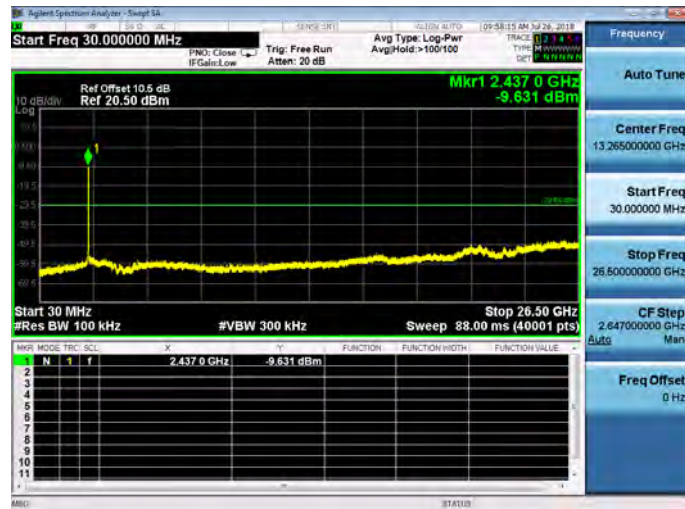

2452 MHz





Conducted Band Edge

Mode 2: IEEE 802.11b Continuous TX mode

2412 MHz

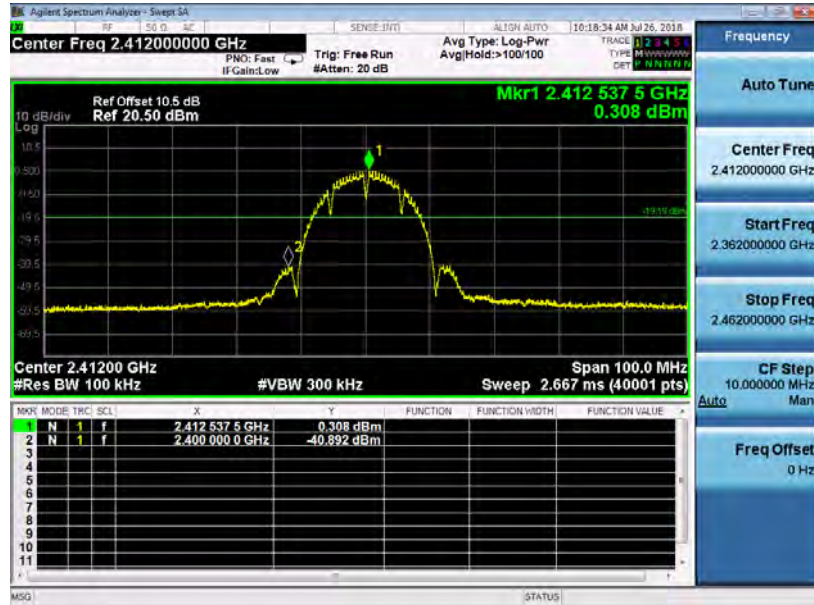

2462 MHz

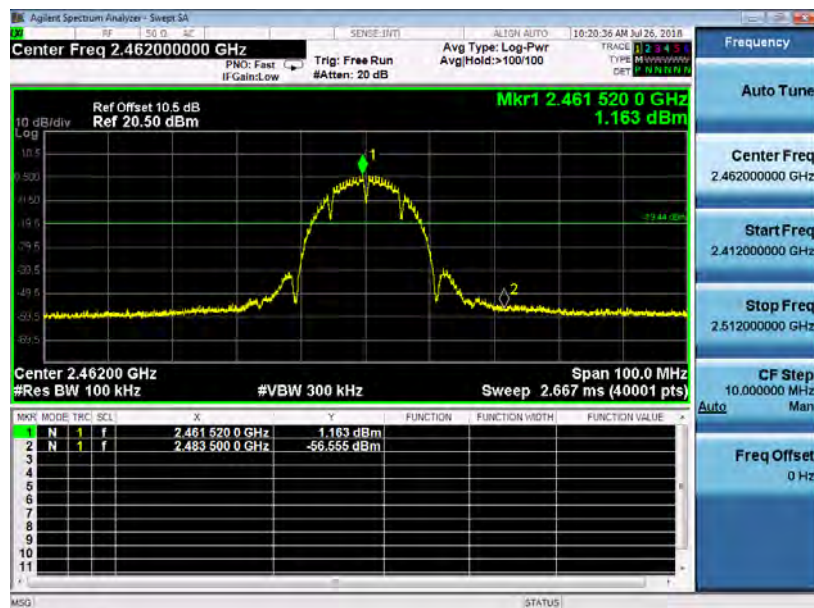

Mode 3: IEEE 802.11g Continuous TX mode

2412 MHz

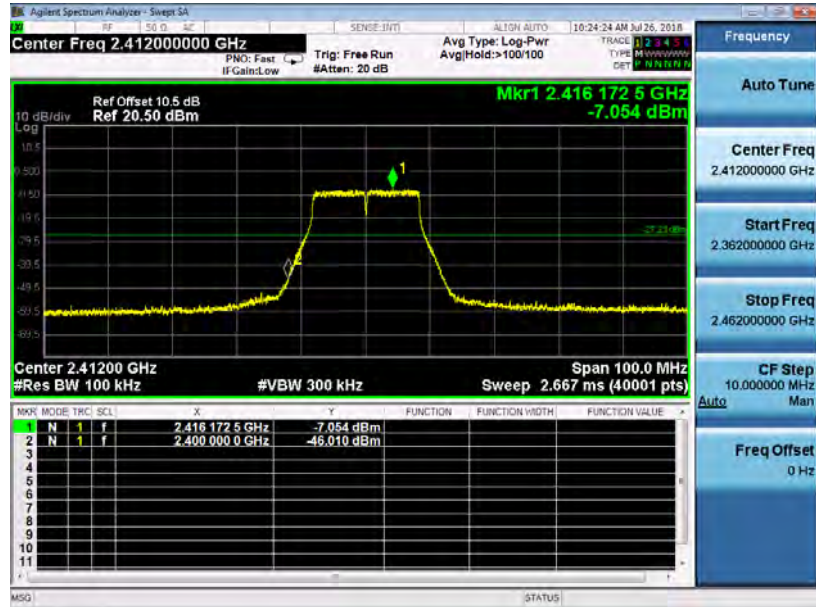

2462 MHz

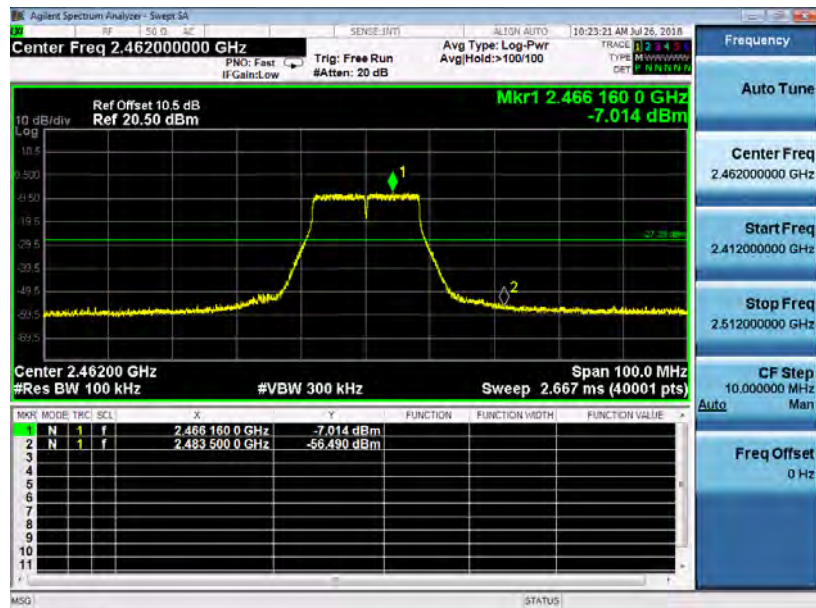

Mode 4: IEEE 802.11n 2.4 GHz 20 MHz Continuous TX mode

2412 MHz

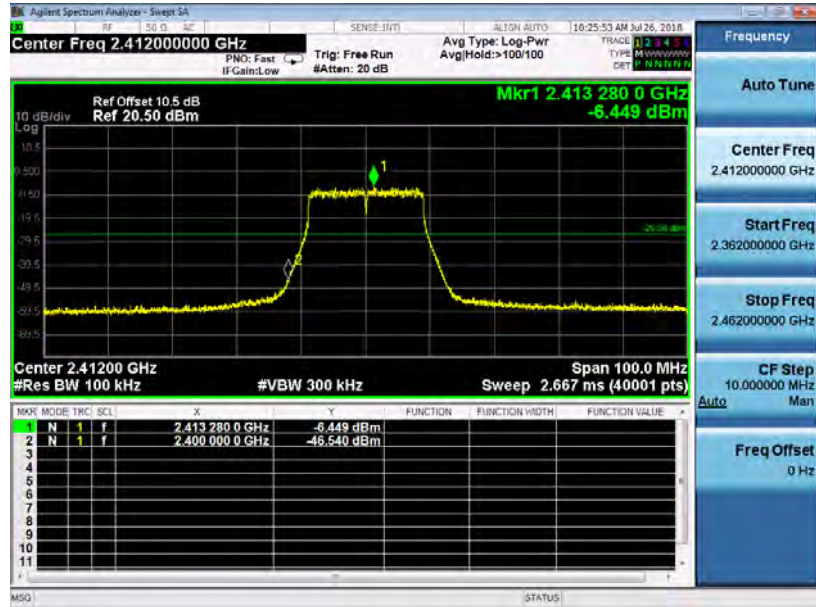

2462 MHz

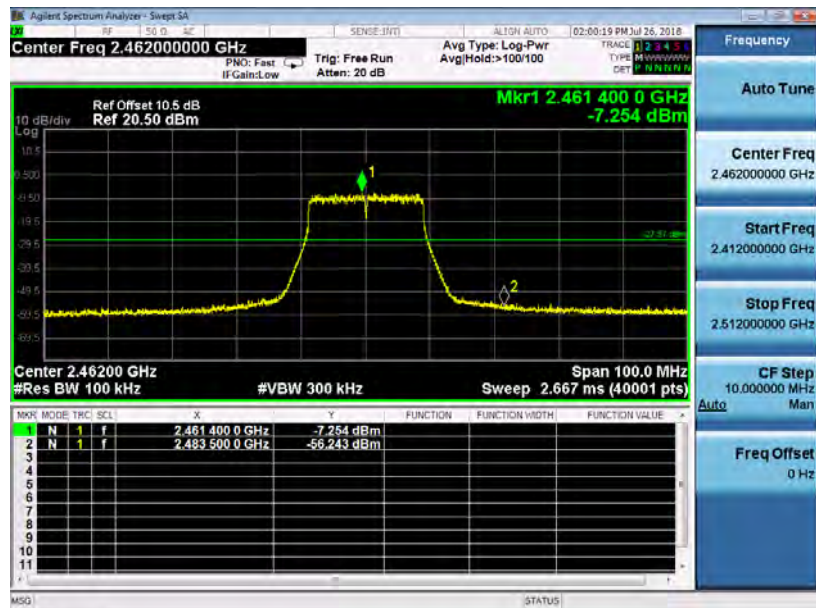



Mode 5: IEEE 802.11n 2.4 GHz 40 MHz Continuous TX mode

2422 MHz

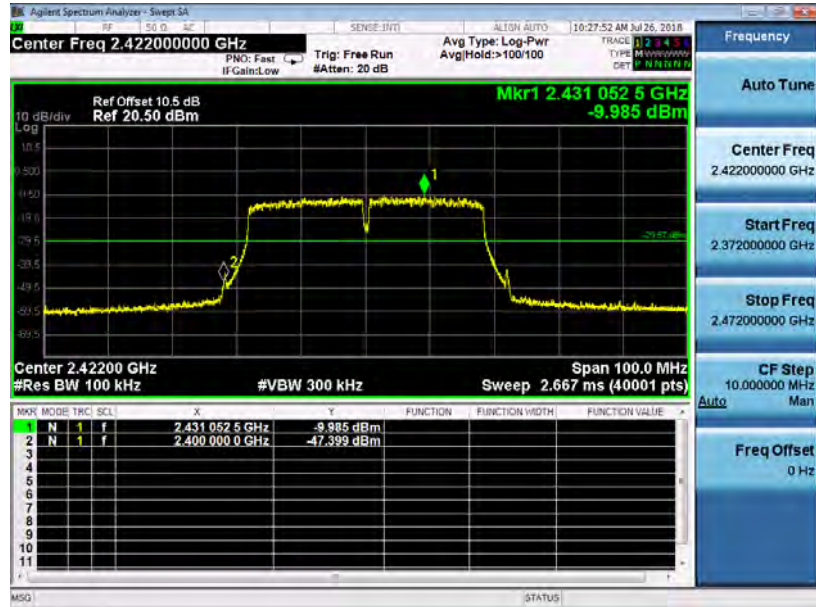

2452 MHz

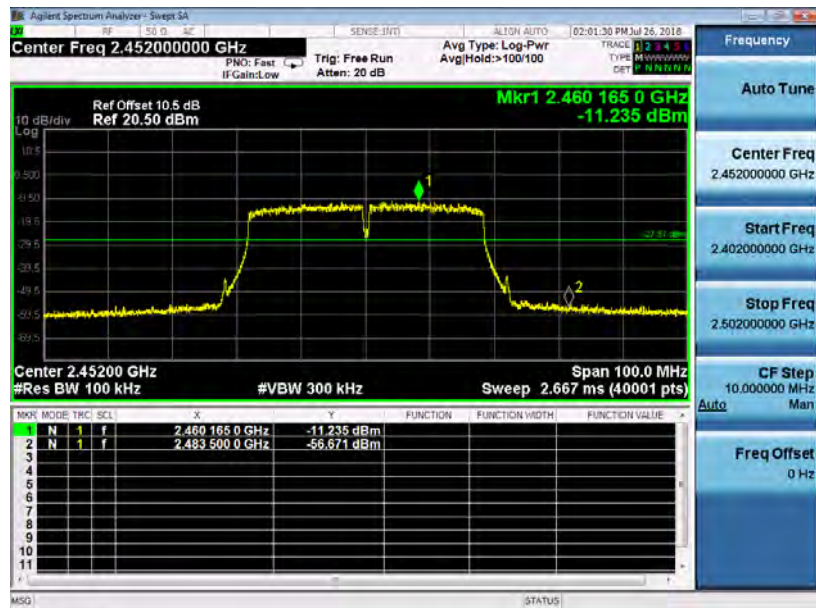



Annex C. Radiated Emission Test Results

Harmonic

Below 1GHz

Standard:		FCC Part 15.247		Test Distance:		3 m	
Test item:		Harmonic		Power:		AC 120 V/60 Hz	
Test Mode:		Mode 1		Temp.(°C)/Hum.(%RH):		26(°C)/60% RH	
Frequency (MHz)	Reading (dBuV)	Correct Factor (dB/m)	Result (dBuV/m)	Limit (dBuV/m)	Margin (dB)	Remark	Ant.Polar. H / V
145.4300	42.00	-10.26	31.74	43.50	-11.76	QP	H
184.2300	45.65	-11.92	33.73	43.50	-9.77	QP	H
200.7200	51.15	-13.08	38.07	43.50	-5.43	QP	H
255.0400	47.31	-12.08	35.23	46.00	-10.77	QP	H
768.1700	28.40	0.10	28.50	46.00	-17.50	QP	H
839.9500	29.57	0.67	30.24	46.00	-15.76	QP	H
63.9500	44.65	-11.79	32.86	40.00	-7.14	QP	V
133.7900	46.29	-11.63	34.66	43.50	-8.84	QP	V
146.4000	44.36	-10.18	34.18	43.50	-9.32	QP	V
201.6900	51.95	-13.24	38.71	43.50	-4.79	QP	V
531.4900	31.63	-4.85	26.78	46.00	-19.22	QP	V
868.0800	28.80	1.14	29.94	46.00	-16.06	QP	V

- Note:
1. Result (dBuV/m) = Correct Factor (dB/m) + Reading(dBuV).
 2. Correction factor (dB/m) = Antenna Factor (dB/m) + Cable loss (dB) – Pre-Amplifier gain (dB).
 3. When the peak results are less than average limit, so not need to evaluate the average.



Above 1GHz

Standard:	FCC Part 15.247	Test Distance:	3 m
Test item:	Harmonic	Power:	AC 120 V/60 Hz
Frequency:	2412 MHz	Temp.(°C)/Hum.(%RH):	26(°C)/60% RH
Mode:	Mode 2		
Ant.Polar.:	Horizontal		

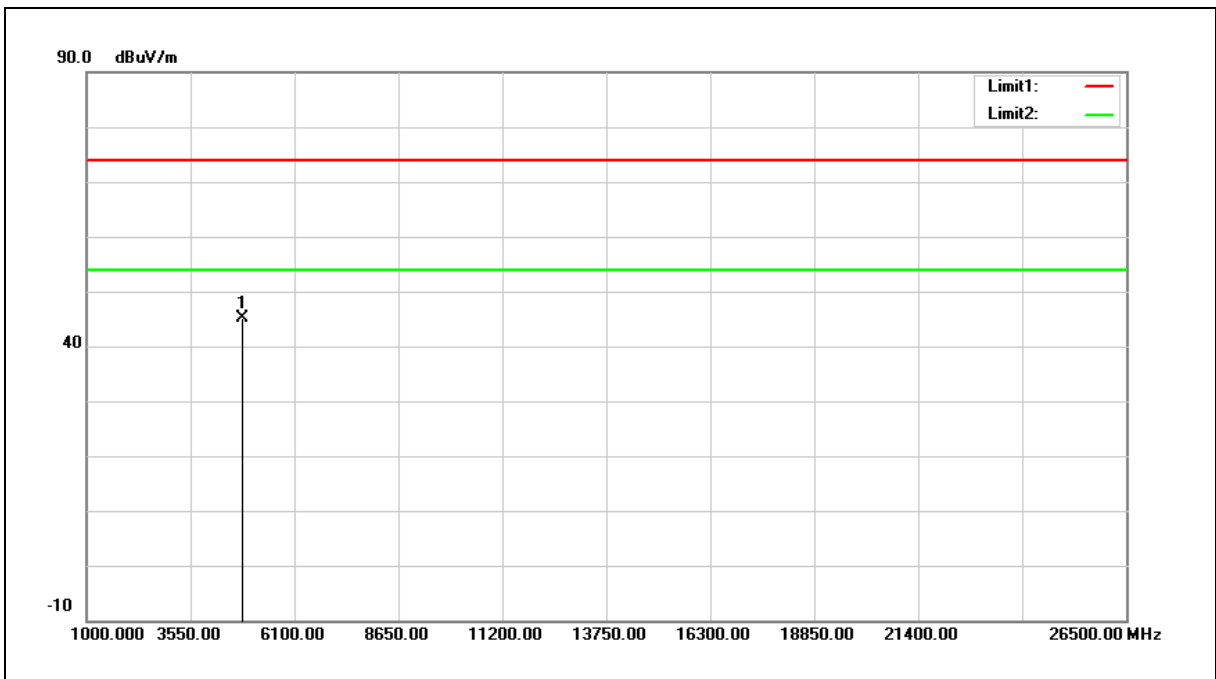

No.	Frequency (MHz)	Reading (dBuV)	Correct Factor (dB/m)	Result (dBuV/m)	Limit (dBuV/m)	Margin (dB)	Remark
1	4824.000	49.46	-4.36	45.10	74.00	-28.90	peak

Note:1.Result (dBuV/m) = Correct Factor (dB/m) + Reading(dBuV).

2.Correction factor (dB/m) = Antenna Factor (dB/m) + Cable loss (dB) – Pre-Amplifier gain (dB).

3.When the peak results are less than average limit, so not need to evaluate the average.



Standard:	FCC Part 15.247	Test Distance:	3 m
Test item:	Harmonic	Power:	AC 120 V/60 Hz
Frequency:	2412 MHz	Temp.(°C)/Hum.(%RH):	26(°C)/60% RH
Mode:	Mode 2		
Ant.Polar.:	Vertical		

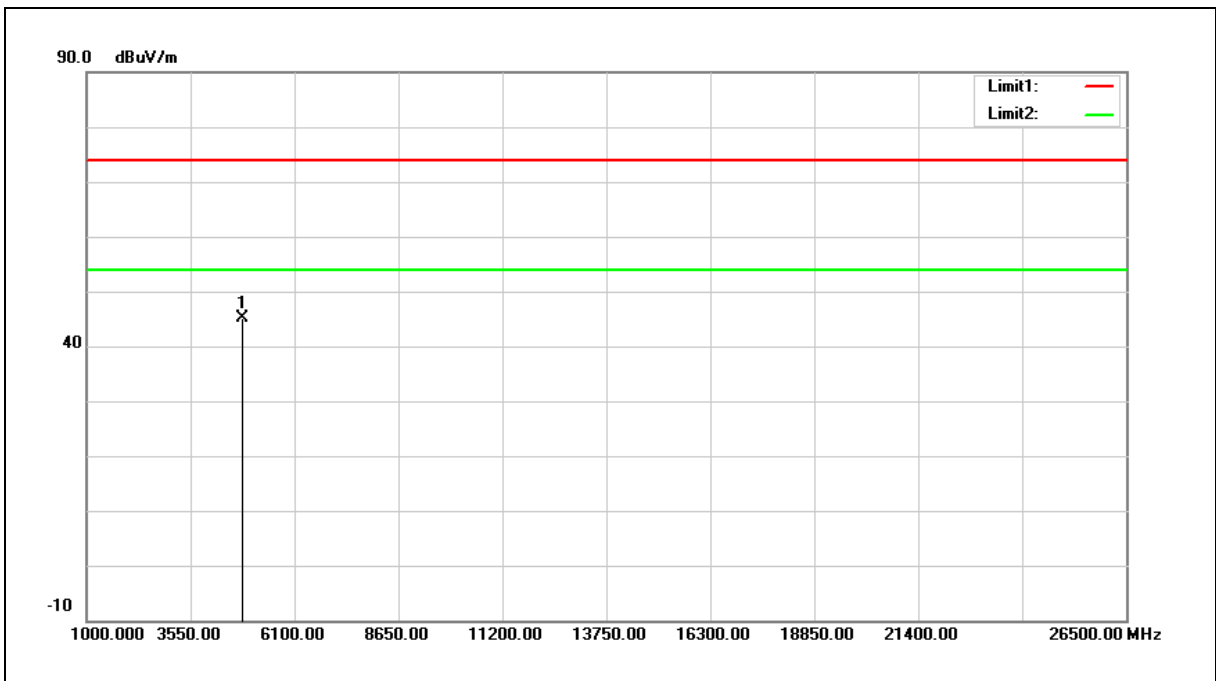

No.	Frequency (MHz)	Reading (dBuV)	Correct Factor (dB/m)	Result (dBuV/m)	Limit (dBuV/m)	Margin (dB)	Remark
1	4824.000	49.59	-4.36	45.23	74.00	-28.77	peak

Note:1.Result (dBuV/m) = Correct Factor (dB/m) + Reading(dBuV).

2.Correction factor (dB/m) = Antenna Factor (dB/m) + Cable loss (dB) – Pre-Amplifier gain (dB).

3.When the peak results are less than average limit, so not need to evaluate the average.



Standard:	FCC Part 15.247	Test Distance:	3 m
Test item:	Harmonic	Power:	AC 120 V/60 Hz
Frequency:	2437 MHz	Temp.(°C)/Hum.(%RH):	26(°C)/60% RH
Mode:	Mode 2		
Ant.Polar.:	Horizontal		

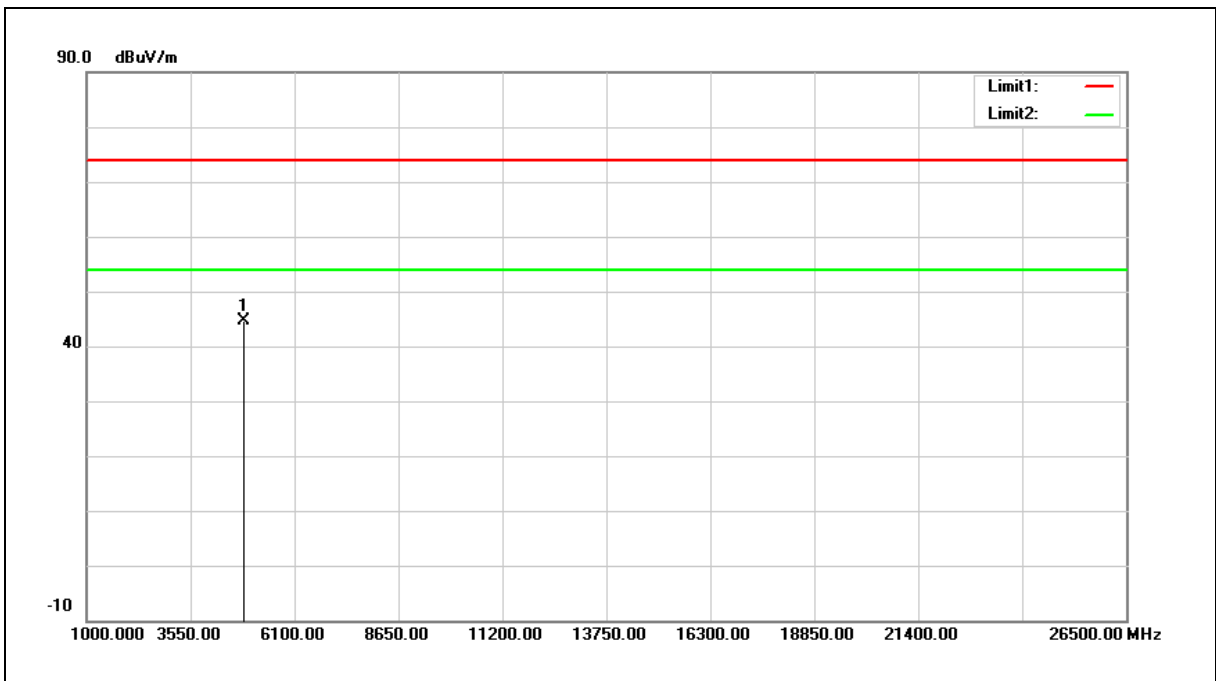

No.	Frequency (MHz)	Reading (dBuV)	Correct Factor (dB/m)	Result (dBuV/m)	Limit (dBuV/m)	Margin (dB)	Remark
1	4874.000	48.92	-4.37	44.55	74.00	-29.45	peak

Note:1.Result (dBuV/m) = Correct Factor (dB/m) + Reading(dBuV).

2.Correction factor (dB/m) = Antenna Factor (dB/m) + Cable loss (dB) – Pre-Amplifier gain (dB).

3.When the peak results are less than average limit, so not need to evaluate the average.



Standard:	FCC Part 15.247	Test Distance:	3 m
Test item:	Harmonic	Power:	AC 120 V/60 Hz
Frequency:	2437 MHz	Temp.(°C)/Hum.(%RH):	26(°C)/60% RH
Mode:	Mode 2		
Ant.Polar.:	Vertical		

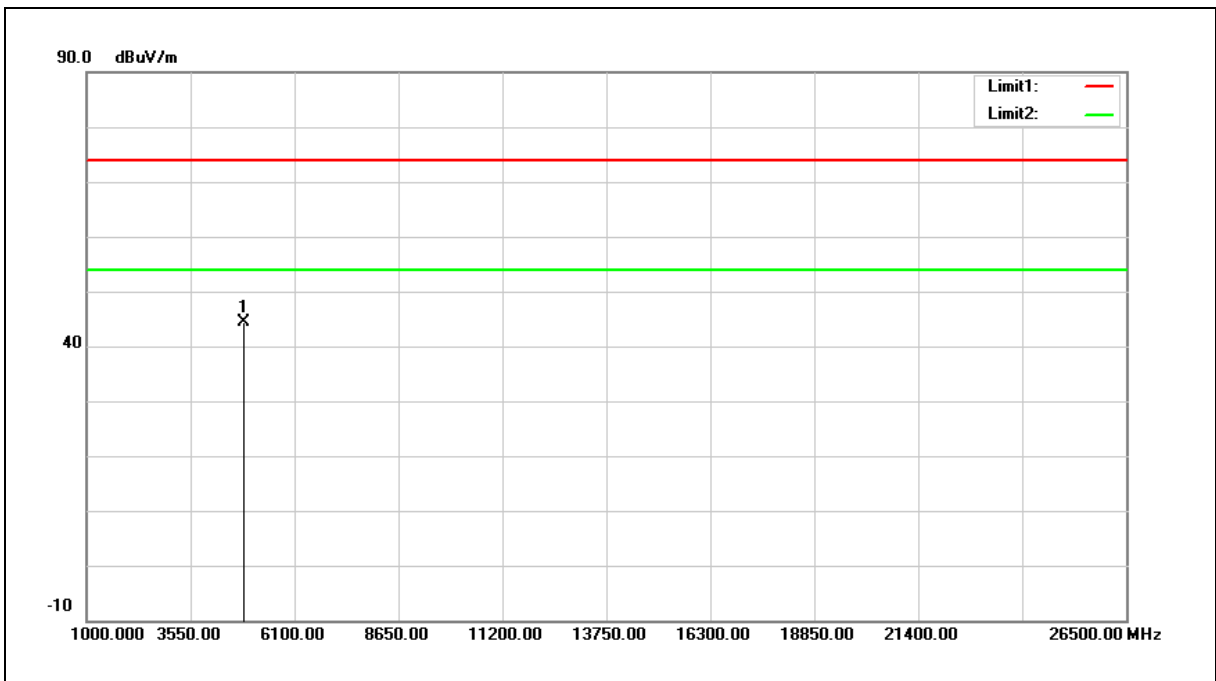

No.	Frequency (MHz)	Reading (dBuV)	Correct Factor (dB/m)	Result (dBuV/m)	Limit (dBuV/m)	Margin (dB)	Remark
1	4874.000	48.87	-4.37	44.50	74.00	-29.50	peak

Note:1.Result (dBuV/m) = Correct Factor (dB/m) + Reading(dBuV).

2.Correction factor (dB/m) = Antenna Factor (dB/m) + Cable loss (dB) – Pre-Amplifier gain (dB).

3.When the peak results are less than average limit, so not need to evaluate the average.



Standard:	FCC Part 15.247	Test Distance:	3 m
Test item:	Harmonic	Power:	AC 120 V/60 Hz
Frequency:	2462 MHz	Temp.(°C)/Hum.(%RH):	26(°C)/60% RH
Mode:	Mode 2		
Ant.Polar.:	Horizontal		

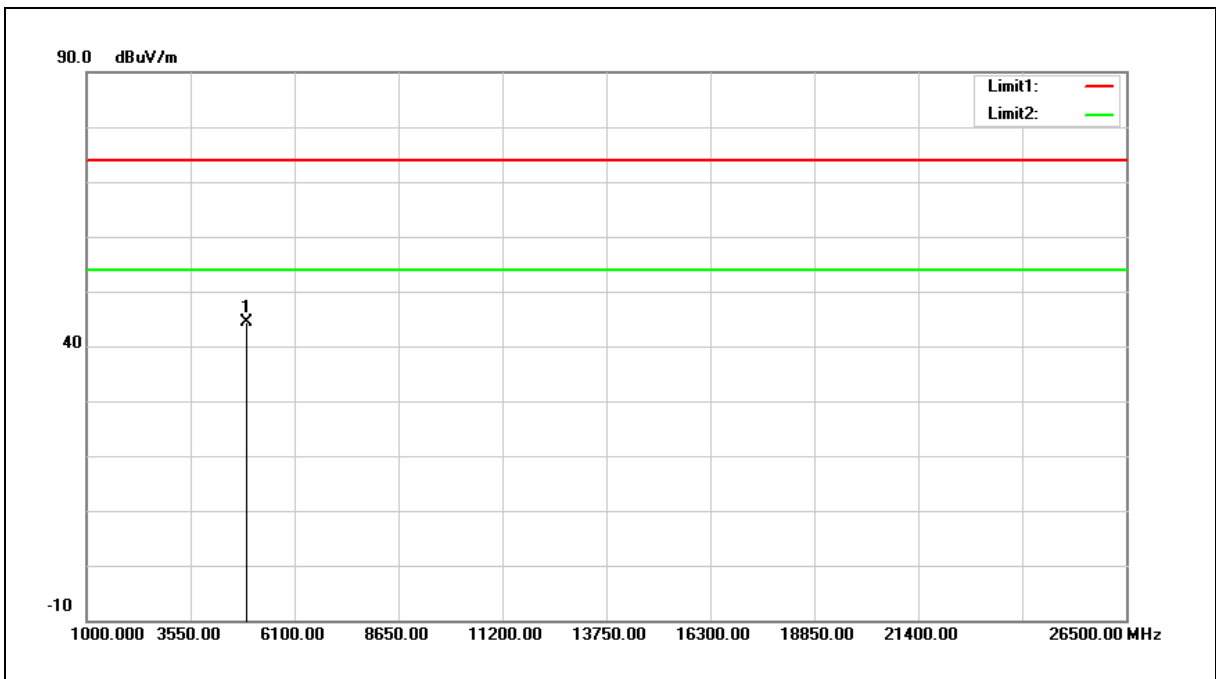

No.	Frequency (MHz)	Reading (dBuV)	Correct Factor (dB/m)	Result (dBuV/m)	Limit (dBuV/m)	Margin (dB)	Remark
1	4924.000	48.70	-4.39	44.31	74.00	-29.69	peak

Note:1.Result (dBuV/m) = Correct Factor (dB/m) + Reading(dBuV).

2.Correction factor (dB/m) = Antenna Factor (dB/m) + Cable loss (dB) – Pre-Amplifier gain (dB).

3.When the peak results are less than average limit, so not need to evaluate the average.



Standard:	FCC Part 15.247	Test Distance:	3 m
Test item:	Harmonic	Power:	AC 120 V/60 Hz
Frequency:	2462 MHz	Temp.(°C)/Hum.(%RH):	26(°C)/60% RH
Mode:	Mode 2		
Ant.Polar.:	Vertical		

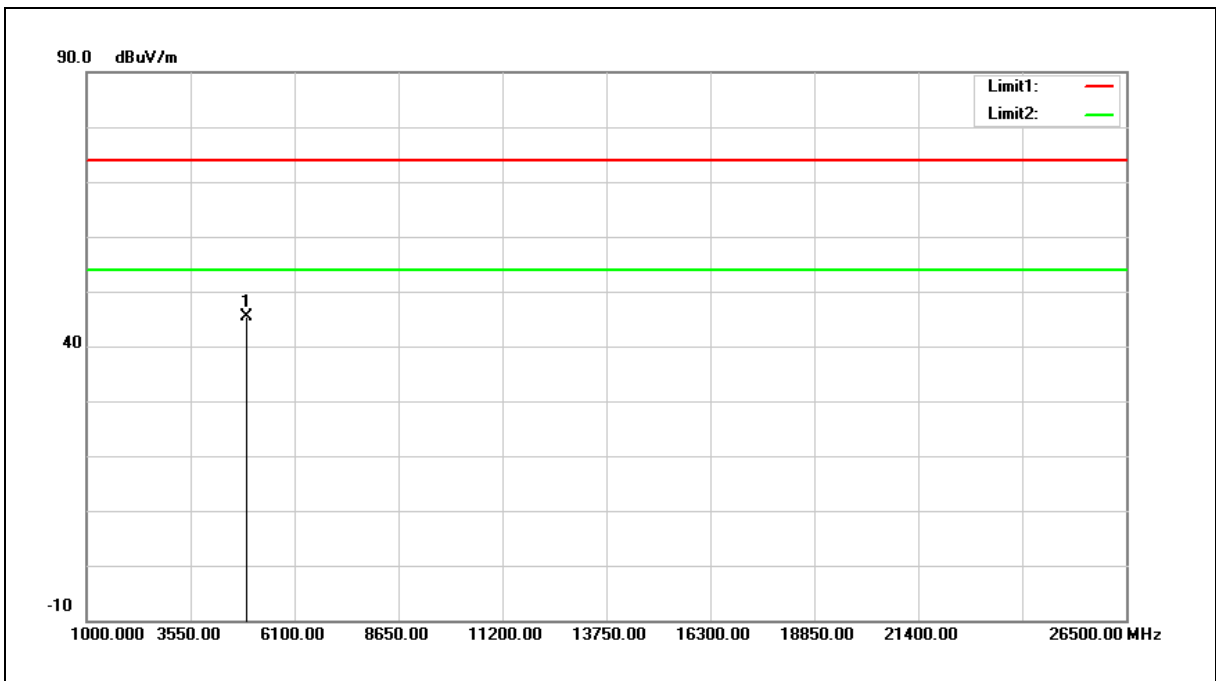

No.	Frequency (MHz)	Reading (dBuV)	Correct Factor (dB/m)	Result (dBuV/m)	Limit (dBuV/m)	Margin (dB)	Remark
1	4924.000	49.80	-4.39	45.41	74.00	-28.59	peak

Note:1.Result (dBuV/m) = Correct Factor (dB/m) + Reading(dBuV).

2.Correction factor (dB/m) = Antenna Factor (dB/m) + Cable loss (dB) – Pre-Amplifier gain (dB).

3.When the peak results are less than average limit, so not need to evaluate the average.



Standard:	FCC Part 15.247	Test Distance:	3 m
Test item:	Harmonic	Power:	AC 120 V/60 Hz
Frequency:	2412 MHz	Temp.(°C)/Hum.(%RH):	26(°C)/60% RH
Mode:	Mode 3		
Ant.Polar.:	Horizontal		

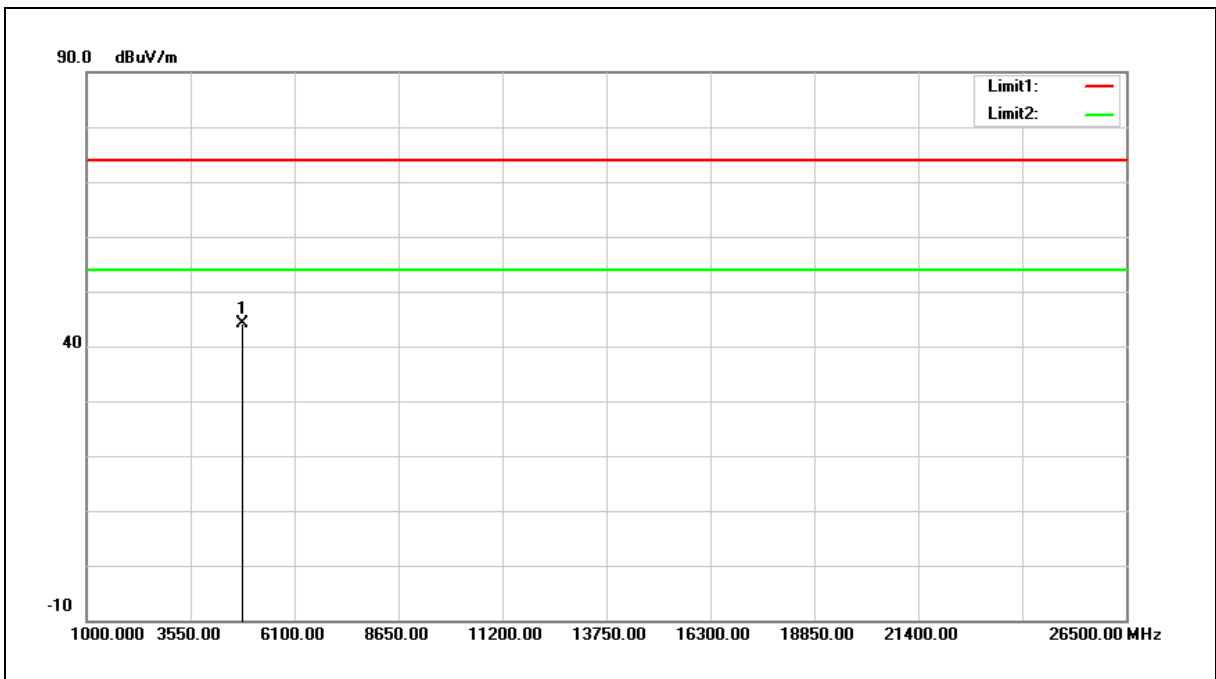

No.	Frequency (MHz)	Reading (dBuV)	Correct Factor (dB/m)	Result (dBuV/m)	Limit (dBuV/m)	Margin (dB)	Remark
1	4824.000	48.47	-4.36	44.11	74.00	-29.89	peak

Note:1.Result (dBuV/m) = Correct Factor (dB/m) + Reading(dBuV).

2.Correction factor (dB/m) = Antenna Factor (dB/m) + Cable loss (dB) – Pre-Amplifier gain (dB).

3.When the peak results are less than average limit, so not need to evaluate the average.



Standard:	FCC Part 15.247	Test Distance:	3 m
Test item:	Harmonic	Power:	AC 120 V/60 Hz
Frequency:	2412 MHz	Temp.(°C)/Hum.(%RH):	26(°C)/60% RH
Mode:	Mode 3		
Ant.Polar.:	Vertical		

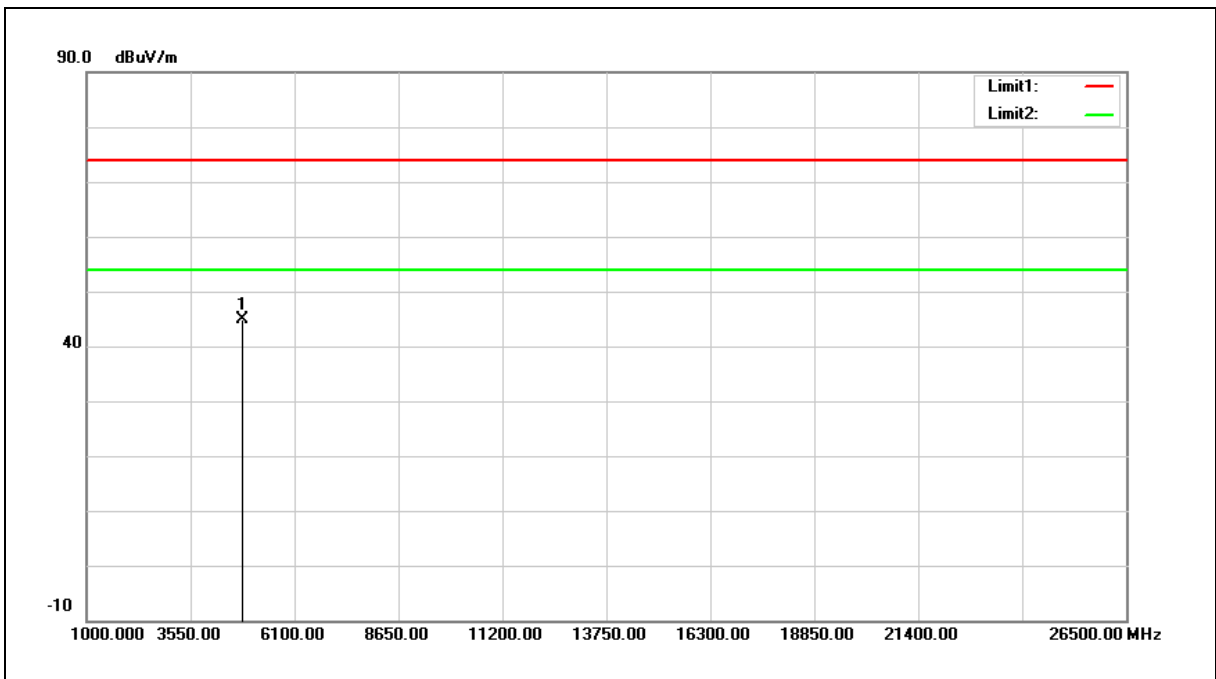

No.	Frequency (MHz)	Reading (dBuV)	Correct Factor (dB/m)	Result (dBuV/m)	Limit (dBuV/m)	Margin (dB)	Remark
1	4824.000	49.29	-4.36	44.93	74.00	-29.07	peak

Note:1.Result (dBuV/m) = Correct Factor (dB/m) + Reading(dBuV).

2.Correction factor (dB/m) = Antenna Factor (dB/m) + Cable loss (dB) – Pre-Amplifier gain (dB).

3.When the peak results are less than average limit, so not need to evaluate the average.



Standard:	FCC Part 15.247	Test Distance:	3 m
Test item:	Harmonic	Power:	AC 120 V/60 Hz
Frequency:	2437 MHz	Temp.(°C)/Hum.(%RH):	26(°C)/60% RH
Mode:	Mode 3		
Ant.Polar.:	Horizontal		

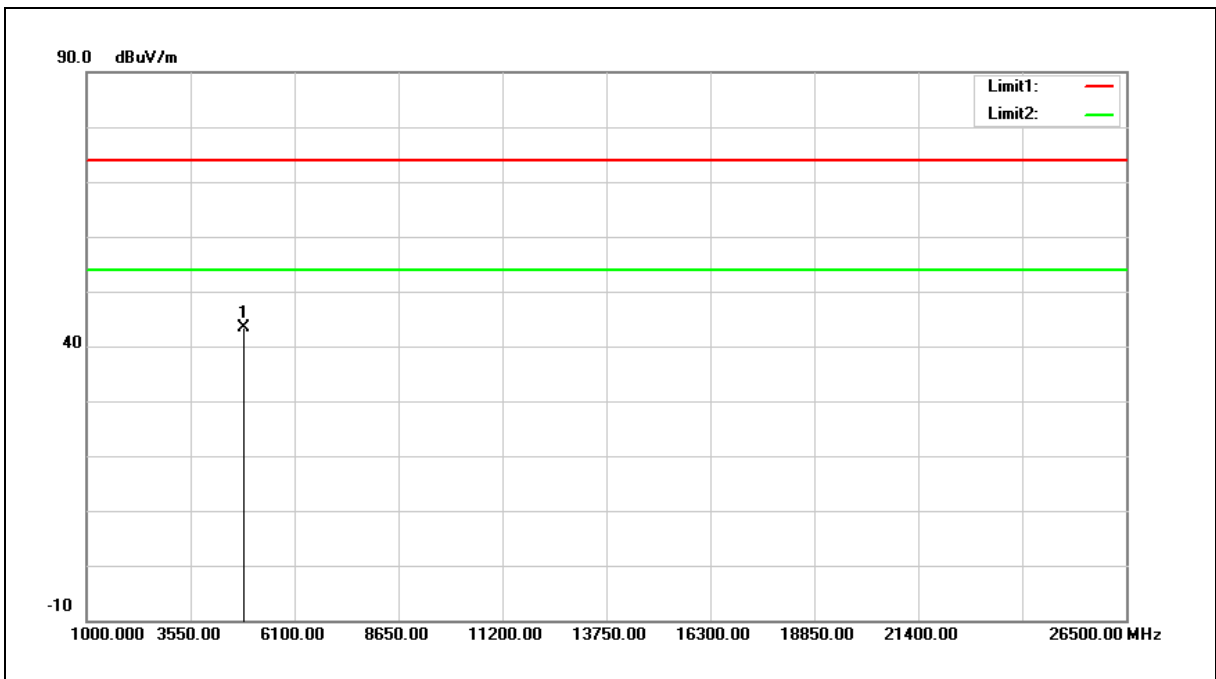

No.	Frequency (MHz)	Reading (dBuV)	Correct Factor (dB/m)	Result (dBuV/m)	Limit (dBuV/m)	Margin (dB)	Remark
1	4874.000	47.69	-4.37	43.32	74.00	-30.68	peak

Note:1.Result (dBuV/m) = Correct Factor (dB/m) + Reading(dBuV).

2.Correction factor (dB/m) = Antenna Factor (dB/m) + Cable loss (dB) – Pre-Amplifier gain (dB).

3.When the peak results are less than average limit, so not need to evaluate the average.



Standard:	FCC Part 15.247	Test Distance:	3 m
Test item:	Harmonic	Power:	AC 120 V/60 Hz
Frequency:	2437 MHz	Temp.(°C)/Hum.(%RH):	26(°C)/60% RH
Mode:	Mode 3		
Ant.Polar.:	Vertical		

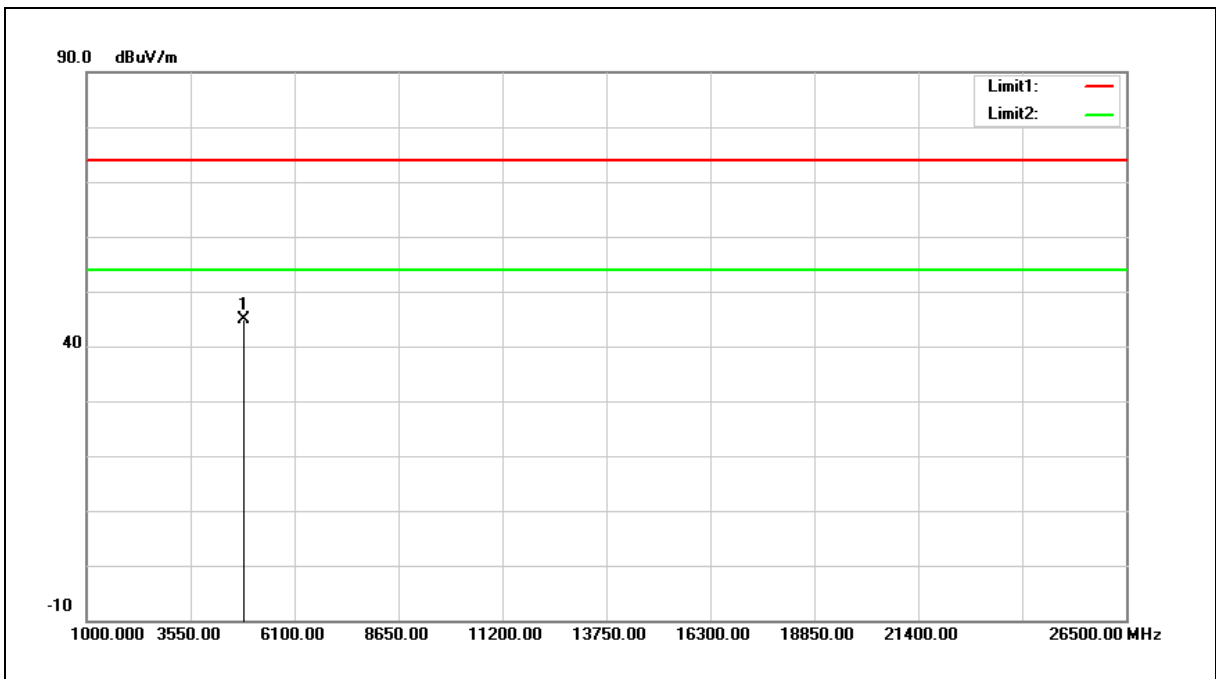

No.	Frequency (MHz)	Reading (dBuV)	Correct Factor (dB/m)	Result (dBuV/m)	Limit (dBuV/m)	Margin (dB)	Remark
1	4874.000	49.13	-4.37	44.76	74.00	-29.24	peak

Note:1.Result (dBuV/m) = Correct Factor (dB/m) + Reading(dBuV).

2.Correction factor (dB/m) = Antenna Factor (dB/m) + Cable loss (dB) – Pre-Amplifier gain (dB).

3.When the peak results are less than average limit, so not need to evaluate the average.



Standard:	FCC Part 15.247	Test Distance:	3 m
Test item:	Harmonic	Power:	AC 120 V/60 Hz
Frequency:	2462 MHz	Temp.(°C)/Hum.(%RH):	26(°C)/60% RH
Mode:	Mode 3		
Ant.Polar.:	Horizontal		

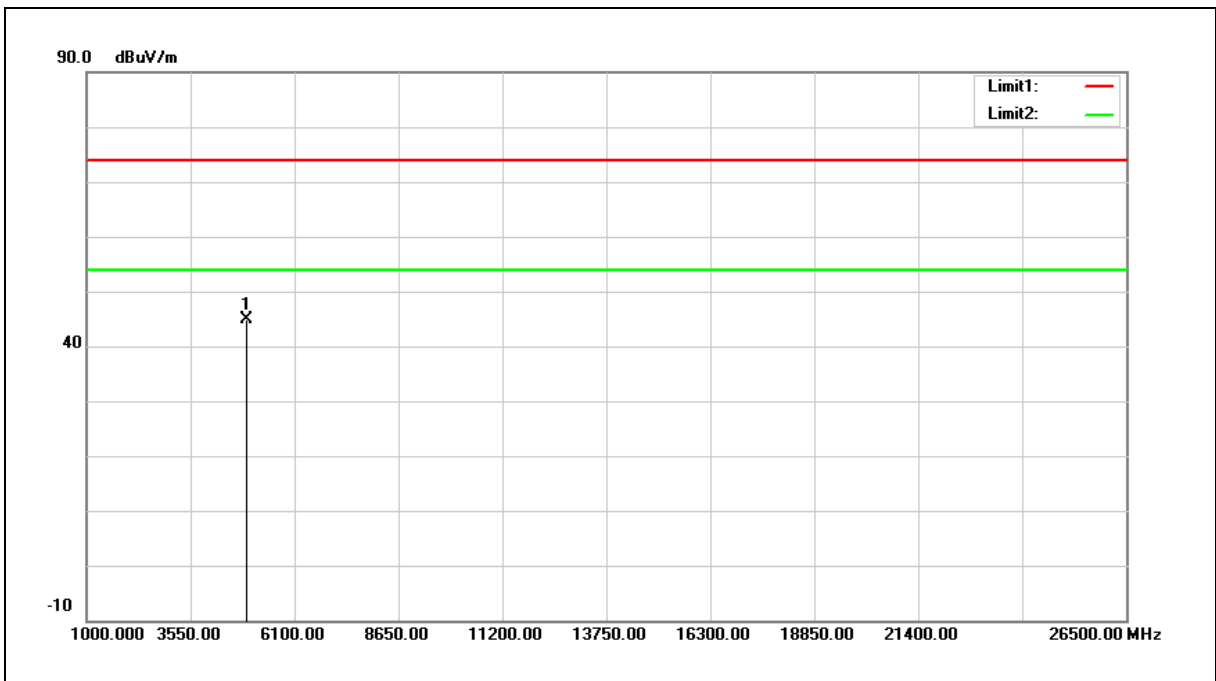

No.	Frequency (MHz)	Reading (dBuV)	Correct Factor (dB/m)	Result (dBuV/m)	Limit (dBuV/m)	Margin (dB)	Remark
1	4924.000	49.18	-4.39	44.79	74.00	-29.21	peak

Note:1.Result (dBuV/m) = Correct Factor (dB/m) + Reading(dBuV).

2.Correction factor (dB/m) = Antenna Factor (dB/m) + Cable loss (dB) – Pre-Amplifier gain (dB).

3.When the peak results are less than average limit, so not need to evaluate the average.



Standard:	FCC Part 15.247	Test Distance:	3 m
Test item:	Harmonic	Power:	AC 120 V/60 Hz
Frequency:	2462 MHz	Temp.(°C)/Hum.(%RH):	26(°C)/60% RH
Mode:	Mode 3		
Ant.Polar.:	Vertical		

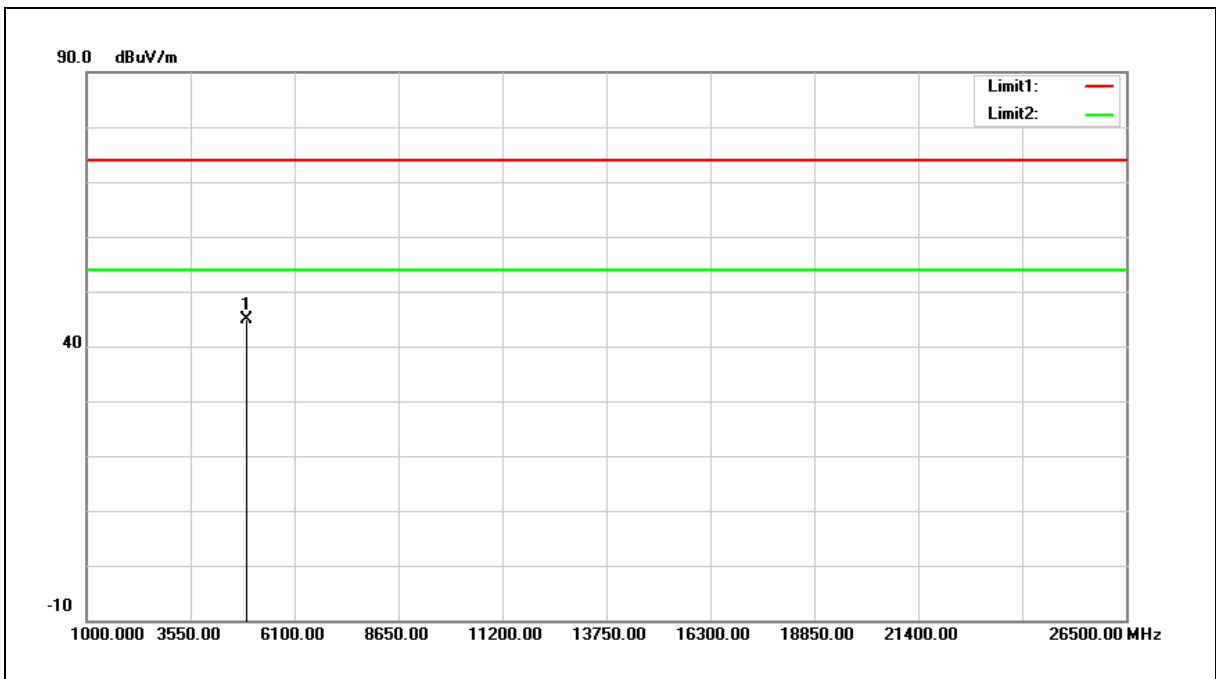

No.	Frequency (MHz)	Reading (dBuV)	Correct Factor (dB/m)	Result (dBuV/m)	Limit (dBuV/m)	Margin (dB)	Remark
1	4924.000	49.33	-4.39	44.94	74.00	-29.06	peak

Note:1.Result (dBuV/m) = Correct Factor (dB/m) + Reading(dBuV).

2.Correction factor (dB/m) = Antenna Factor (dB/m) + Cable loss (dB) – Pre-Amplifier gain (dB).

3.When the peak results are less than average limit, so not need to evaluate the average.



Standard:	FCC Part 15.247	Test Distance:	3 m
Test item:	Harmonic	Power:	AC 120 V/60 Hz
Frequency:	2412 MHz	Temp.(°C)/Hum.(%RH):	26(°C)/60% RH
Mode:	Mode 4		
Ant.Polar.:	Horizontal		

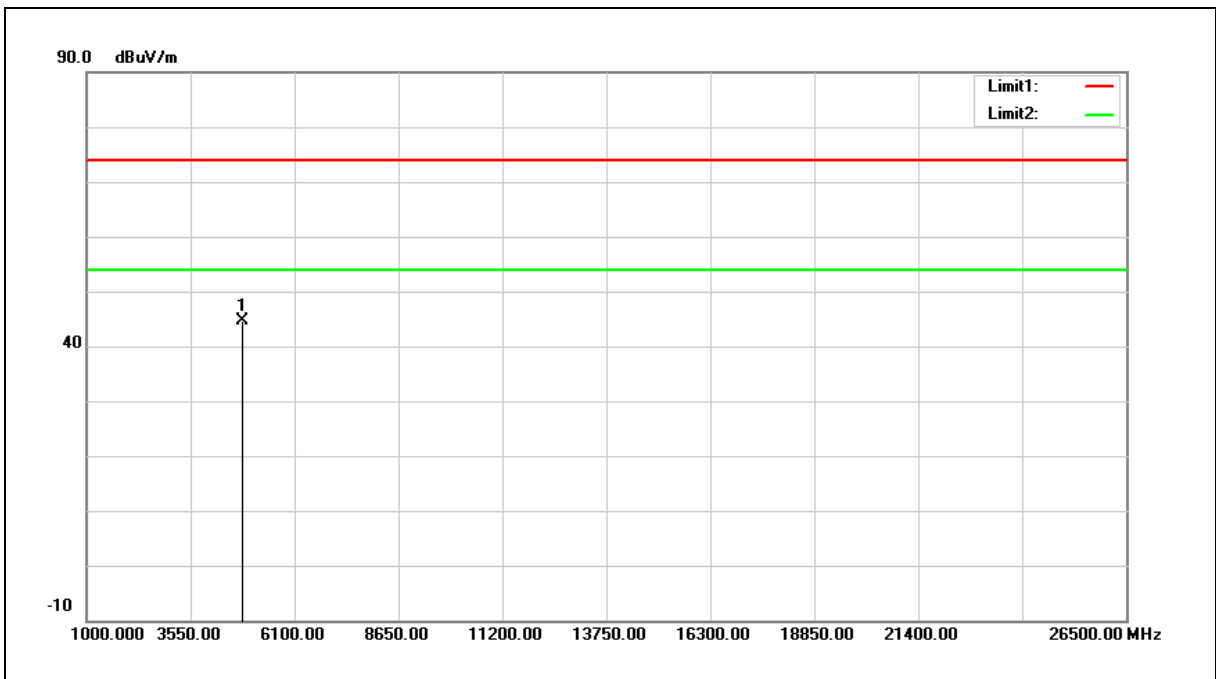

No.	Frequency (MHz)	Reading (dBuV)	Correct Factor (dB/m)	Result (dBuV/m)	Limit (dBuV/m)	Margin (dB)	Remark
1	4824.000	48.91	-4.36	44.55	74.00	-29.45	peak

Note:1.Result (dBuV/m) = Correct Factor (dB/m) + Reading(dBuV).

2.Correction factor (dB/m) = Antenna Factor (dB/m) + Cable loss (dB) – Pre-Amplifier gain (dB).

3.When the peak results are less than average limit, so not need to evaluate the average.



Standard:	FCC Part 15.247	Test Distance:	3 m
Test item:	Harmonic	Power:	AC 120 V/60 Hz
Frequency:	2412 MHz	Temp.(°C)/Hum.(%RH):	26(°C)/60% RH
Mode:	Mode 4		
Ant.Polar.:	Vertical		

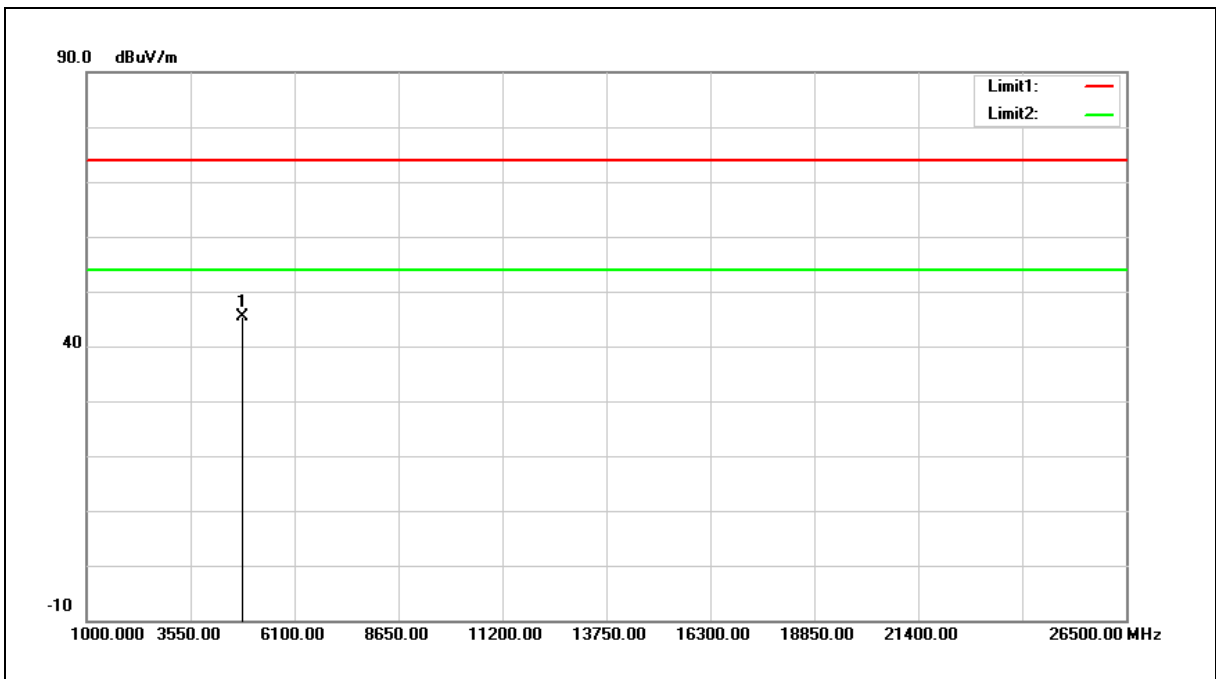

No.	Frequency (MHz)	Reading (dBuV)	Correct Factor (dB/m)	Result (dBuV/m)	Limit (dBuV/m)	Margin (dB)	Remark
1	4824.000	49.68	-4.36	45.32	74.00	-28.68	peak

Note:1.Result (dBuV/m) = Correct Factor (dB/m) + Reading(dBuV).

2.Correction factor (dB/m) = Antenna Factor (dB/m) + Cable loss (dB) – Pre-Amplifier gain (dB).

3.When the peak results are less than average limit, so not need to evaluate the average.



Standard:	FCC Part 15.247	Test Distance:	3 m
Test item:	Harmonic	Power:	AC 120 V/60 Hz
Frequency:	2437 MHz	Temp.(°C)/Hum.(%RH):	26(°C)/60% RH
Mode:	Mode 4		
Ant.Polar.:	Horizontal		

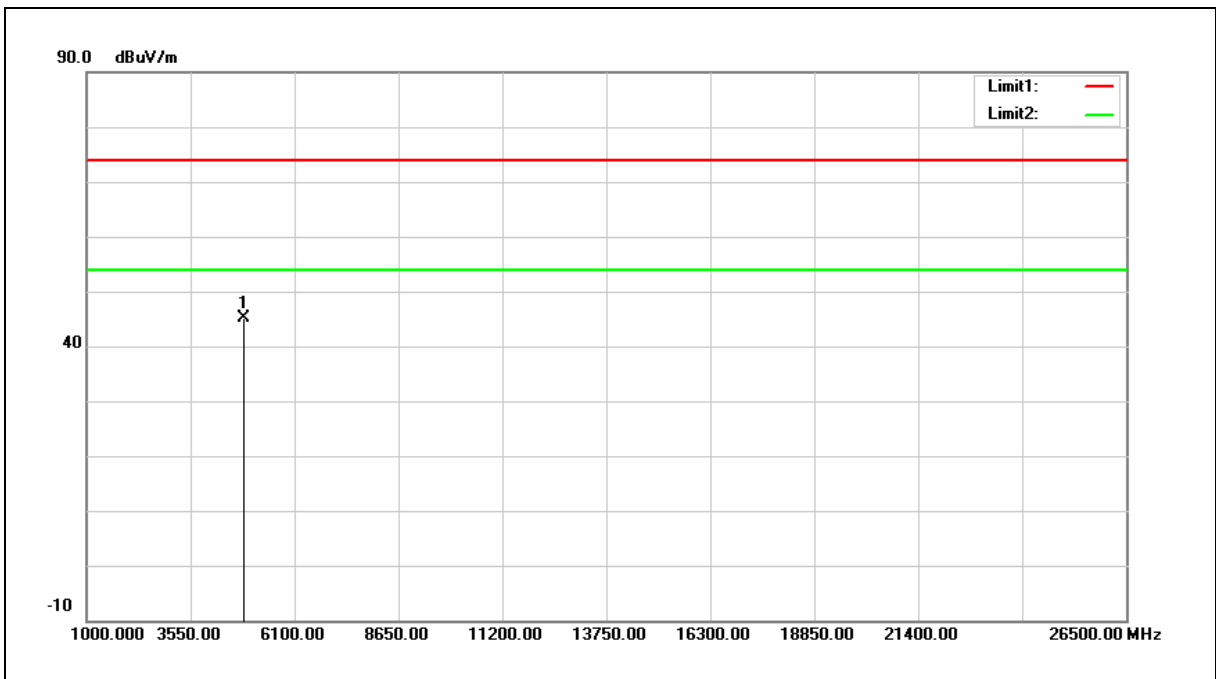

No.	Frequency (MHz)	Reading (dBuV)	Correct Factor (dB/m)	Result (dBuV/m)	Limit (dBuV/m)	Margin (dB)	Remark
1	4874.000	49.46	-4.37	45.09	74.00	-28.91	peak

Note:1.Result (dBuV/m) = Correct Factor (dB/m) + Reading(dBuV).

2.Correction factor (dB/m) = Antenna Factor (dB/m) + Cable loss (dB) – Pre-Amplifier gain (dB).

3.When the peak results are less than average limit, so not need to evaluate the average.



Standard:	FCC Part 15.247	Test Distance:	3 m
Test item:	Harmonic	Power:	AC 120 V/60 Hz
Frequency:	2437 MHz	Temp.(°C)/Hum.(%RH):	26(°C)/60% RH
Mode:	Mode 4		
Ant.Polar.:	Vertical		

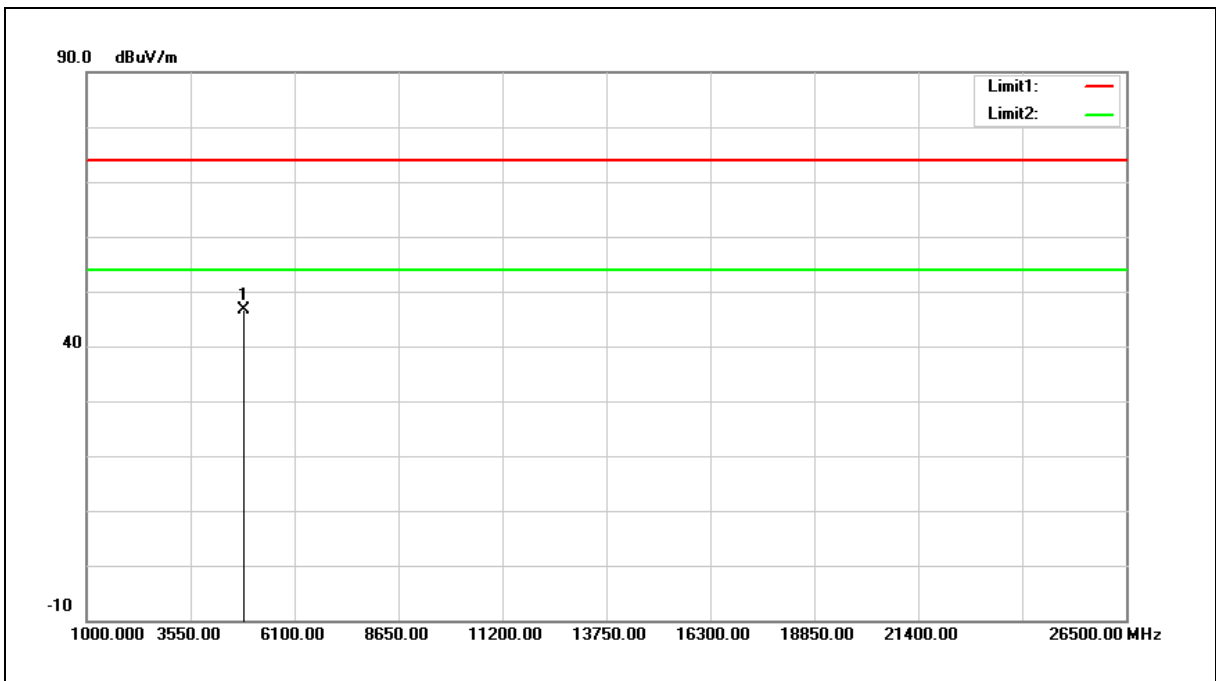

No.	Frequency (MHz)	Reading (dBuV)	Correct Factor (dB/m)	Result (dBuV/m)	Limit (dBuV/m)	Margin (dB)	Remark
1	4874.000	50.92	-4.37	46.55	74.00	-27.45	peak

Note:1.Result (dBuV/m) = Correct Factor (dB/m) + Reading(dBuV).

2.Correction factor (dB/m) = Antenna Factor (dB/m) + Cable loss (dB) – Pre-Amplifier gain (dB).

3.When the peak results are less than average limit, so not need to evaluate the average.



Standard:	FCC Part 15.247	Test Distance:	3 m
Test item:	Harmonic	Power:	AC 120 V/60 Hz
Frequency:	2462 MHz	Temp.(°C)/Hum.(%RH):	26(°C)/60% RH
Mode:	Mode 4		
Ant.Polar.:	Horizontal		

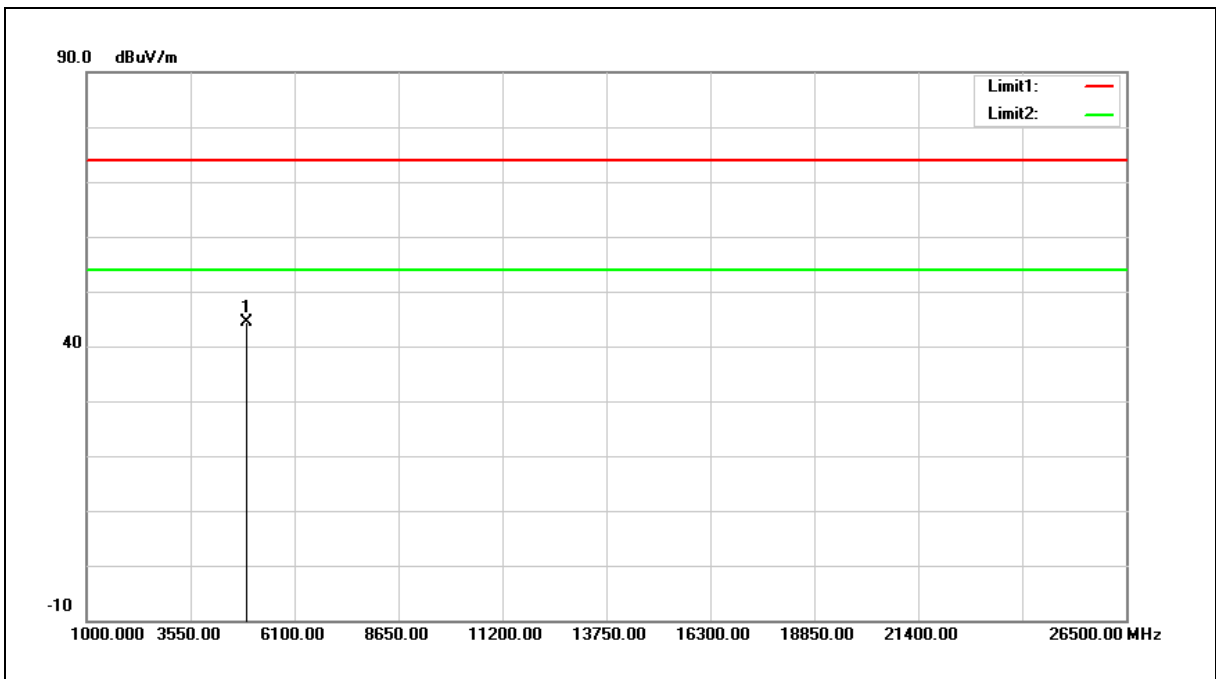

No.	Frequency (MHz)	Reading (dBuV)	Correct Factor (dB/m)	Result (dBuV/m)	Limit (dBuV/m)	Margin (dB)	Remark
1	4924.000	48.76	-4.39	44.37	74.00	-29.63	peak

Note:1.Result (dBuV/m) = Correct Factor (dB/m) + Reading(dBuV).

2.Correction factor (dB/m) = Antenna Factor (dB/m) + Cable loss (dB) – Pre-Amplifier gain (dB).

3.When the peak results are less than average limit, so not need to evaluate the average.



Standard:	FCC Part 15.247	Test Distance:	3 m
Test item:	Harmonic	Power:	AC 120 V/60 Hz
Frequency:	2462 MHz	Temp.(°C)/Hum.(%RH):	26(°C)/60% RH
Mode:	Mode 4		
Ant.Polar.:	Vertical		

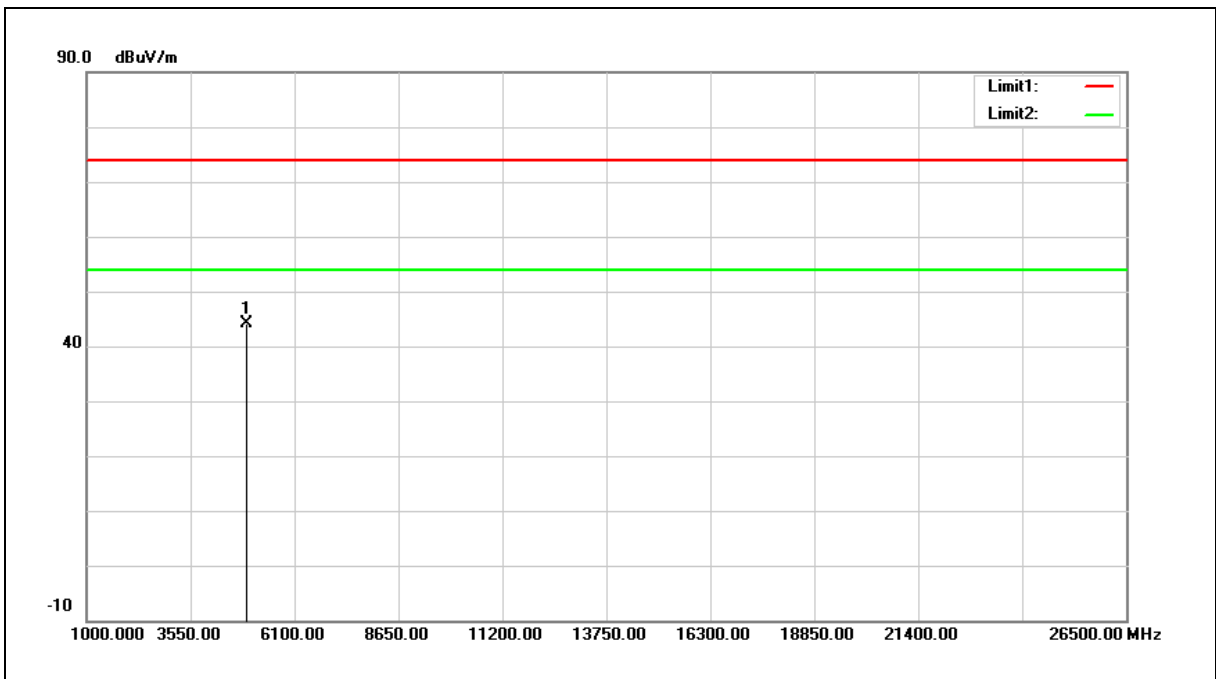

No.	Frequency (MHz)	Reading (dBuV)	Correct Factor (dB/m)	Result (dBuV/m)	Limit (dBuV/m)	Margin (dB)	Remark
1	4924.000	48.54	-4.39	44.15	74.00	-29.85	peak

Note:1.Result (dBuV/m) = Correct Factor (dB/m) + Reading(dBuV).

2.Correction factor (dB/m) = Antenna Factor (dB/m) + Cable loss (dB) – Pre-Amplifier gain (dB).

3.When the peak results are less than average limit, so not need to evaluate the average.



Standard:	FCC Part 15.247	Test Distance:	3 m
Test item:	Harmonic	Power:	AC 120 V/60 Hz
Frequency:	2422 MHz	Temp.(°C)/Hum.(%RH):	26(°C)/60% RH
Mode:	Mode 5		
Ant.Polar.:	Horizontal		

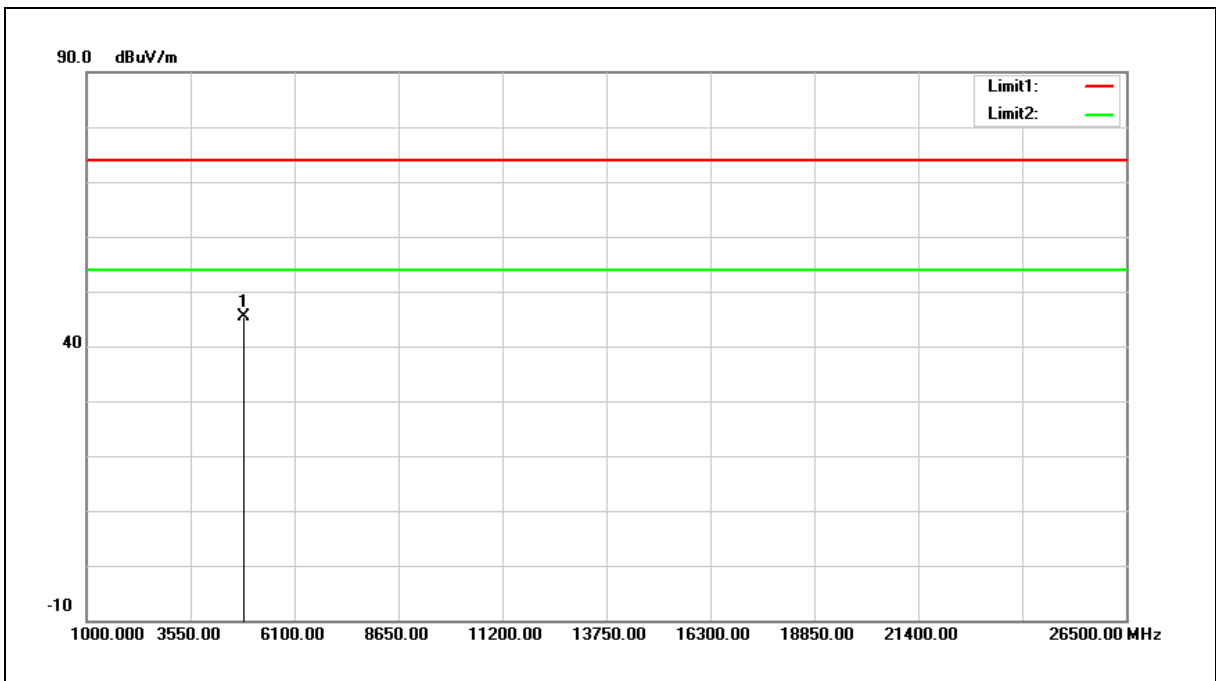

No.	Frequency (MHz)	Reading (dBuV)	Correct Factor (dB/m)	Result (dBuV/m)	Limit (dBuV/m)	Margin (dB)	Remark
1	4844.000	49.69	-4.36	45.33	74.00	-28.67	peak

Note:1.Result (dBuV/m) = Correct Factor (dB/m) + Reading(dBuV).

2.Correction factor (dB/m) = Antenna Factor (dB/m) + Cable loss (dB) – Pre-Amplifier gain (dB).

3.When the peak results are less than average limit, so not need to evaluate the average.



Standard:	FCC Part 15.247	Test Distance:	3 m
Test item:	Harmonic	Power:	AC 120 V/60 Hz
Frequency:	2422 MHz	Temp.(°C)/Hum.(%RH):	26(°C)/60% RH
Mode:	Mode 5		
Ant.Polar.:	Vertical		

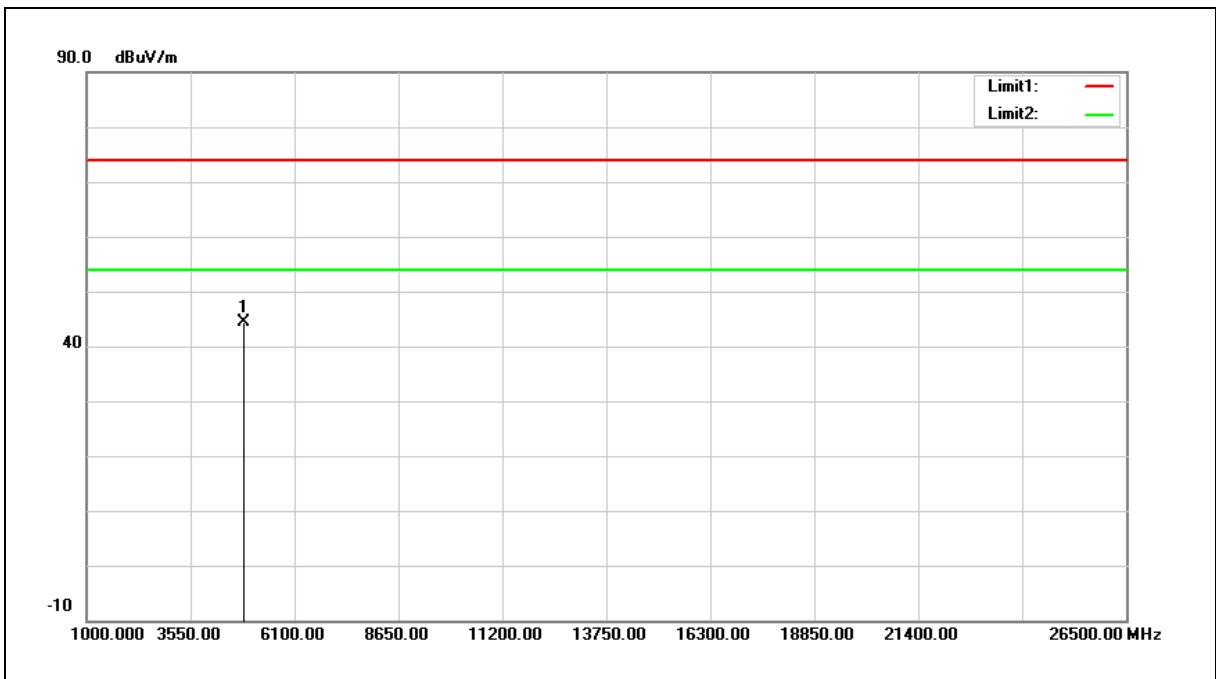

No.	Frequency (MHz)	Reading (dBuV)	Correct Factor (dB/m)	Result (dBuV/m)	Limit (dBuV/m)	Margin (dB)	Remark
1	4844.000	48.79	-4.36	44.43	74.00	-29.57	peak

Note:1.Result (dBuV/m) = Correct Factor (dB/m) + Reading(dBuV).

2.Correction factor (dB/m) = Antenna Factor (dB/m) + Cable loss (dB) – Pre-Amplifier gain (dB).

3.When the peak results are less than average limit, so not need to evaluate the average.



Standard:	FCC Part 15.247	Test Distance:	3 m
Test item:	Harmonic	Power:	AC 120 V/60 Hz
Frequency:	2437 MHz	Temp.(°C)/Hum.(%RH):	26(°C)/60% RH
Mode:	Mode 5		
Ant.Polar.:	Horizontal		

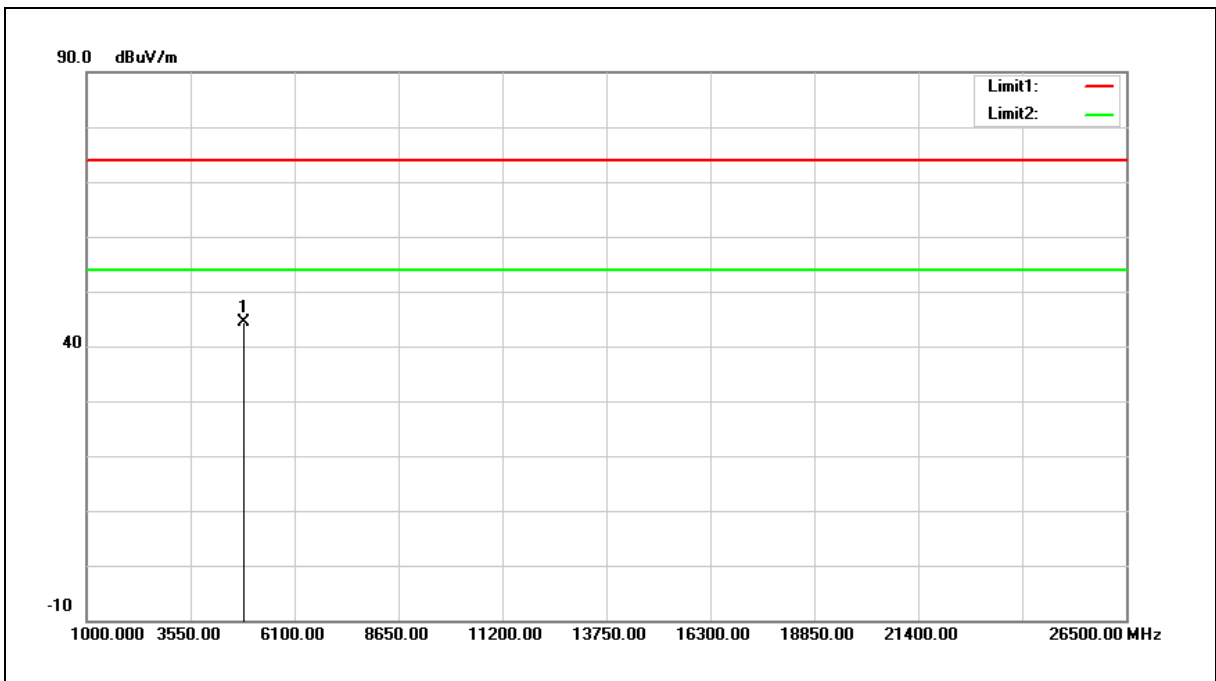

No.	Frequency (MHz)	Reading (dBuV)	Correct Factor (dB/m)	Result (dBuV/m)	Limit (dBuV/m)	Margin (dB)	Remark
1	4874.000	48.81	-4.37	44.44	74.00	-29.56	peak

Note:1.Result (dBuV/m) = Correct Factor (dB/m) + Reading(dBuV).

2.Correction factor (dB/m) = Antenna Factor (dB/m) + Cable loss (dB) – Pre-Amplifier gain (dB).

3.When the peak results are less than average limit, so not need to evaluate the average.



Standard:	FCC Part 15.247	Test Distance:	3 m
Test item:	Harmonic	Power:	AC 120 V/60 Hz
Frequency:	2437 MHz	Temp.(°C)/Hum.(%RH):	26(°C)/60% RH
Mode:	Mode 5		
Ant.Polar.:	Vertical		

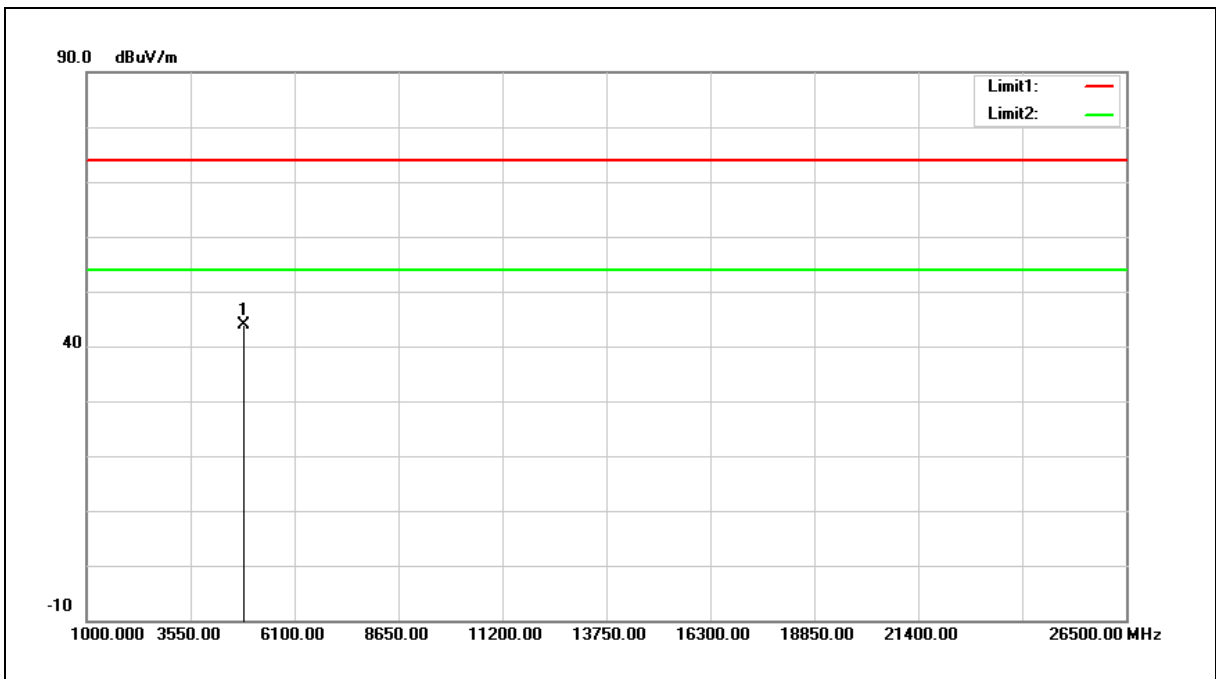

No.	Frequency (MHz)	Reading (dBuV)	Correct Factor (dB/m)	Result (dBuV/m)	Limit (dBuV/m)	Margin (dB)	Remark
1	4874.000	48.14	-4.37	43.77	74.00	-30.23	peak

Note:1.Result (dBuV/m) = Correct Factor (dB/m) + Reading(dBuV).

2.Correction factor (dB/m) = Antenna Factor (dB/m) + Cable loss (dB) – Pre-Amplifier gain (dB).

3.When the peak results are less than average limit, so not need to evaluate the average.



Standard:	FCC Part 15.247	Test Distance:	3 m
Test item:	Harmonic	Power:	AC 120 V/60 Hz
Frequency:	2452 MHz	Temp.(°C)/Hum.(%RH):	26(°C)/60% RH
Mode:	Mode 5		
Ant.Polar.:	Horizontal		

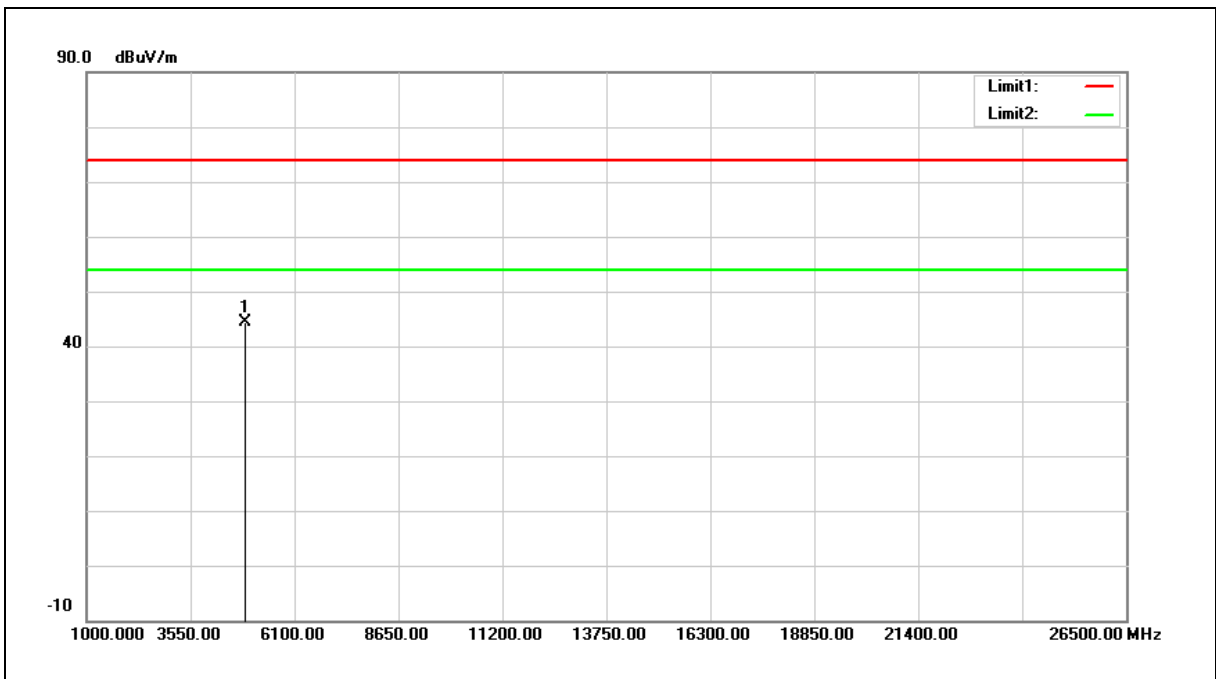

No.	Frequency (MHz)	Reading (dBuV)	Correct Factor (dB/m)	Result (dBuV/m)	Limit (dBuV/m)	Margin (dB)	Remark
1	4904.000	48.83	-4.38	44.45	74.00	-29.55	peak

Note:1.Result (dBuV/m) = Correct Factor (dB/m) + Reading(dBuV).

2.Correction factor (dB/m) = Antenna Factor (dB/m) + Cable loss (dB) – Pre-Amplifier gain (dB).

3.When the peak results are less than average limit, so not need to evaluate the average.



Standard:	FCC Part 15.247	Test Distance:	3 m
Test item:	Harmonic	Power:	AC 120 V/60 Hz
Frequency:	2452 MHz	Temp.(°C)/Hum.(%RH):	26(°C)/60% RH
Mode:	Mode 5		
Ant.Polar.:	Vertical		

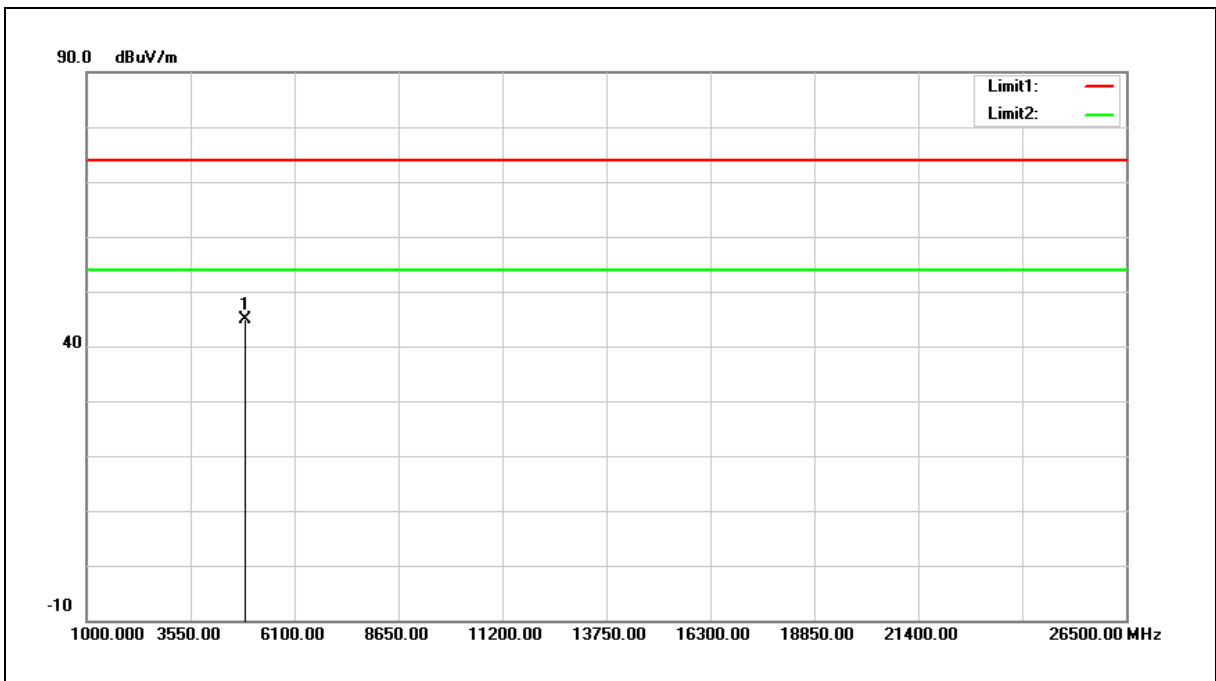

No.	Frequency (MHz)	Reading (dBuV)	Correct Factor (dB/m)	Result (dBuV/m)	Limit (dBuV/m)	Margin (dB)	Remark
1	4904.000	49.38	-4.38	45.00	74.00	-29.00	peak

Note:1.Result (dBuV/m) = Correct Factor (dB/m) + Reading(dBuV).

2.Correction factor (dB/m) = Antenna Factor (dB/m) + Cable loss (dB) – Pre-Amplifier gain (dB).

3.When the peak results are less than average limit, so not need to evaluate the average.

Band Edge

Standard:	FCC Part 15.247	Test Distance:	3 m
Test item:	Band edge	Power:	AC 120 V/60 Hz
Frequency:	2412 MHz	AC 120 V/60 Hz	26(°C)/60% RH
Mode:	Mode 2		
Ant.Polar.:	Horizontal		

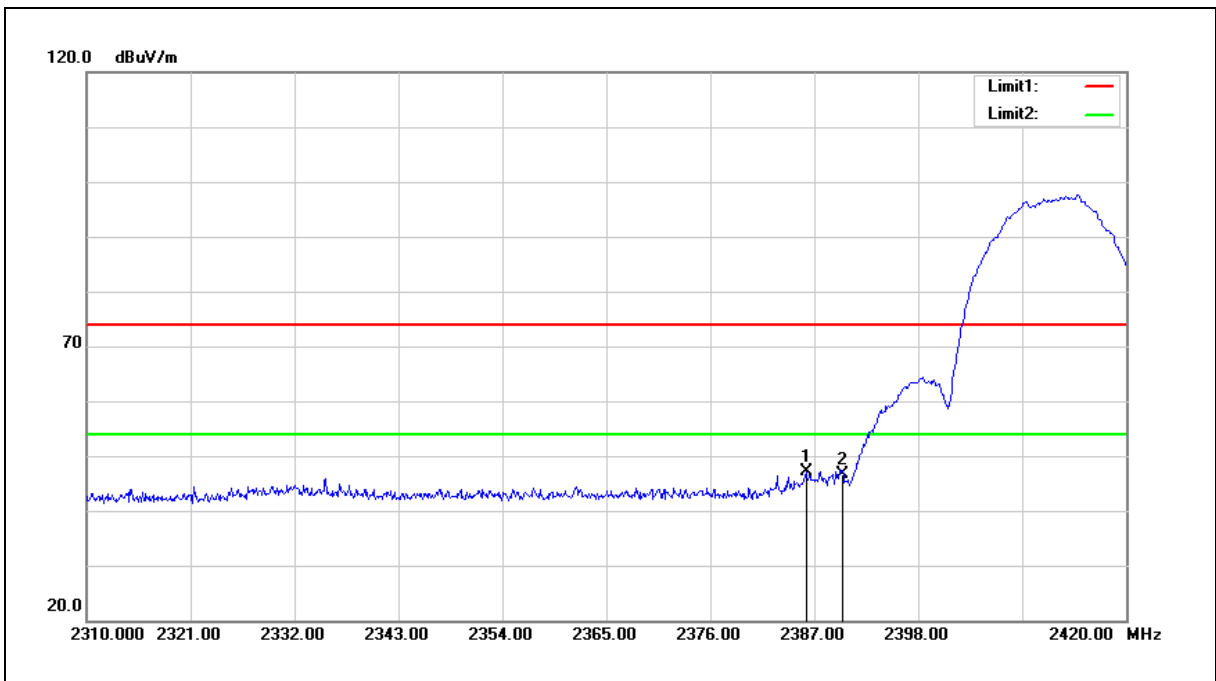

No.	Frequency (MHz)	Reading (dBuV)	Correct Factor (dB/m)	Result (dBuV/m)	Limit (dBuV/m)	Margin (dB)	Remark
1	2386.120	56.87	-9.64	47.23	74.00	-26.77	peak
2	2390.000	56.33	-9.62	46.71	74.00	-27.29	peak

Note:1.Result (dBuV/m) = Correct Factor (dB/m) + Reading(dBuV).

2.Correction factor (dB/m) = Antenna Factor (dB/m) + Cable loss (dB) – Pre-Amplifier gain (dB).

3.When the peak results are less than average limit, so not need to evaluate the average.



Standard:	FCC Part 15.247	Test Distance:	3 m
Test item:	Band edge	Power:	AC 120 V/60 Hz
Frequency:	2412 MHz	AC 120 V/60 Hz	26(°C)/60% RH
Mode:	Mode 2		
Ant.Polar.:	Vertical		

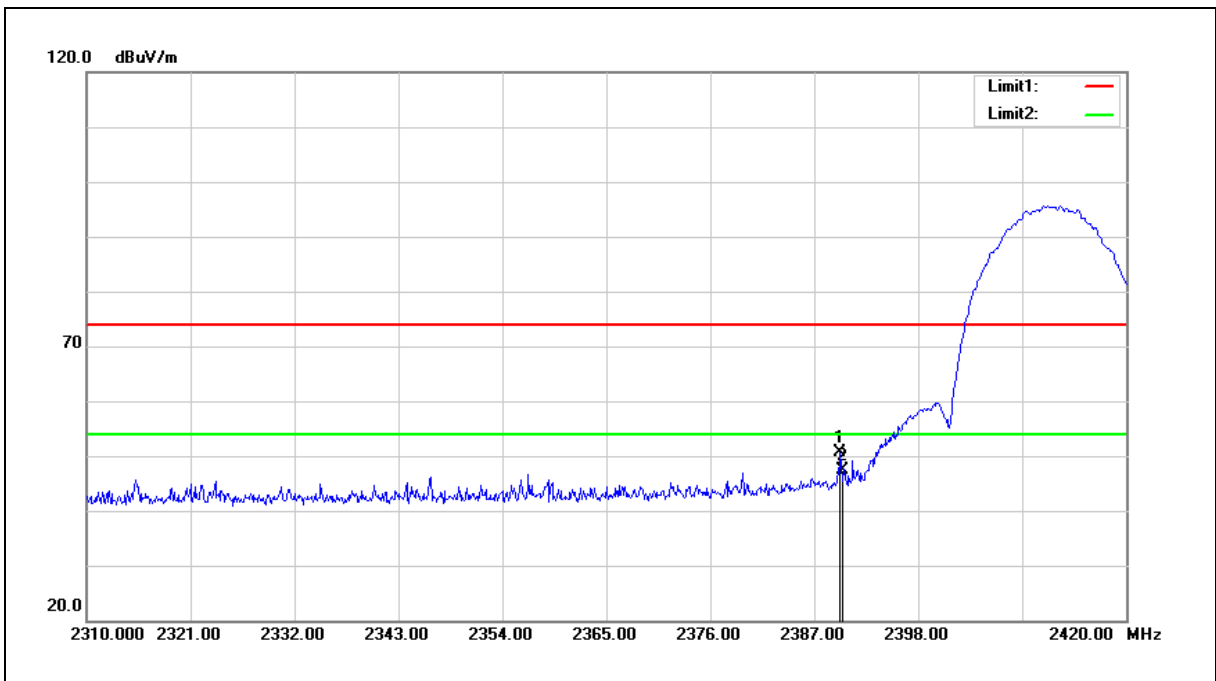

No.	Frequency (MHz)	Reading (dBuV)	Correct Factor (dB/m)	Result (dBuV/m)	Limit (dBuV/m)	Margin (dB)	Remark
1	2389.750	60.24	-9.62	50.62	74.00	-23.38	peak
2	2390.000	56.96	-9.62	47.34	74.00	-26.66	peak

Note:1.Result (dBuV/m) = Correct Factor (dB/m) + Reading(dBuV).

2.Correction factor (dB/m) = Antenna Factor (dB/m) + Cable loss (dB) – Pre-Amplifier gain (dB).

3.When the peak results are less than average limit, so not need to evaluate the average.

Standard:	FCC Part 15.247	Test Distance:	3 m
Test item:	Band edge	Power:	AC 120 V/60 Hz
Frequency:	2462 MHz	AC 120 V/60 Hz	26(°C)/60% RH
Mode:	Mode 2		
Ant.Polar.:	Horizontal		

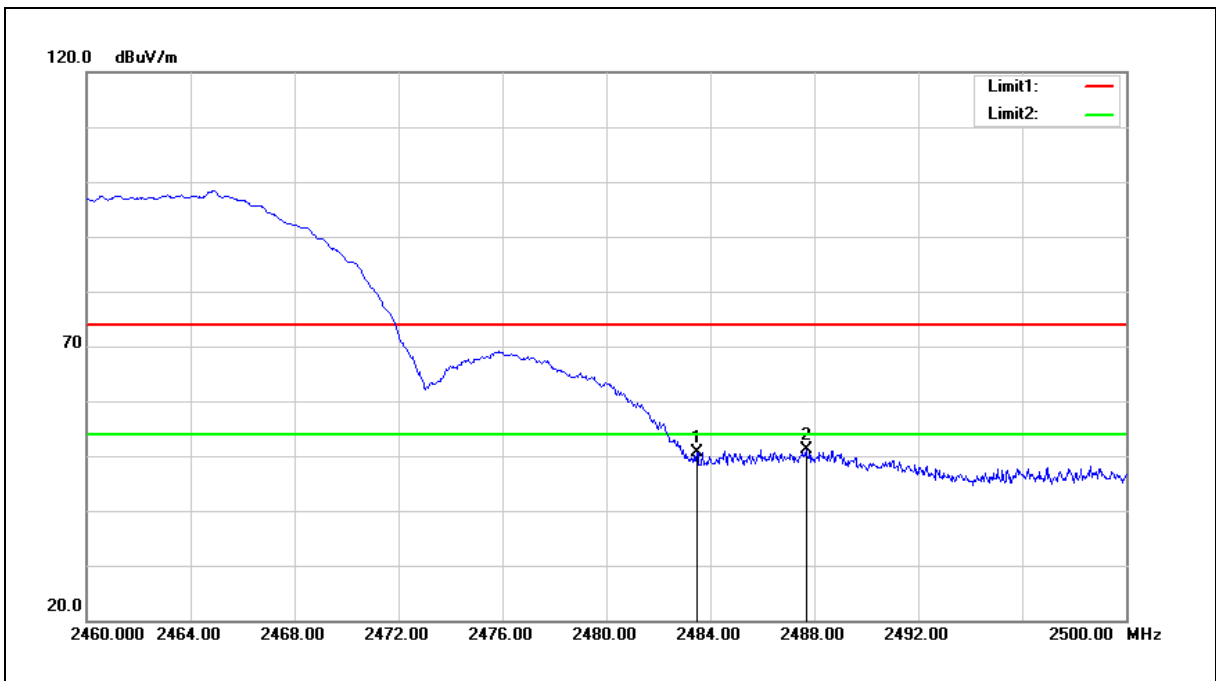

No.	Frequency (MHz)	Reading (dBuV)	Correct Factor (dB/m)	Result (dBuV/m)	Limit (dBuV/m)	Margin (dB)	Remark
1	2483.500	59.82	-9.20	50.62	74.00	-23.38	peak
2	2487.680	60.27	-9.19	51.08	74.00	-22.92	peak

Note:1.Result (dBuV/m) = Correct Factor (dB/m) + Reading(dBuV).

2.Correction factor (dB/m) = Antenna Factor (dB/m) + Cable loss (dB) – Pre-Amplifier gain (dB).

3.When the peak results are less than average limit, so not need to evaluate the average.



Standard:	FCC Part 15.247	Test Distance:	3 m
Test item:	Band edge	Power:	AC 120 V/60 Hz
Frequency:	2462 MHz	AC 120 V/60 Hz	26(°C)/60% RH
Mode:	Mode 2		
Ant.Polar.:	Vertical		

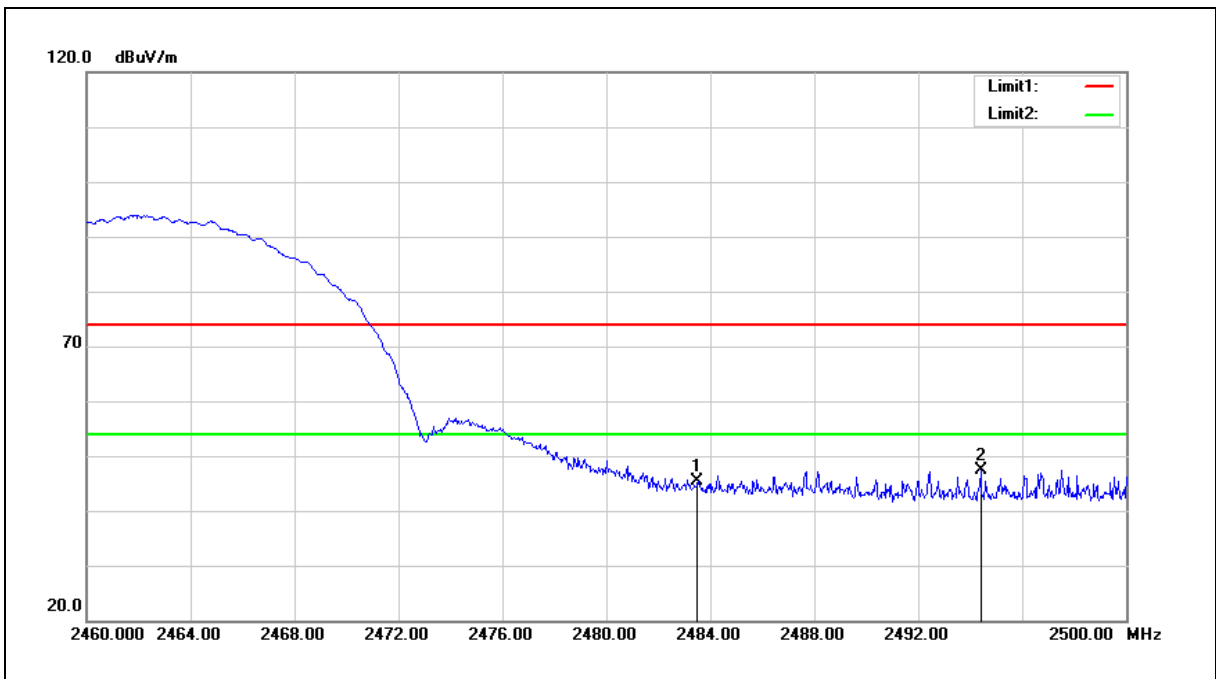

No.	Frequency (MHz)	Reading (dBuV)	Correct Factor (dB/m)	Result (dBuV/m)	Limit (dBuV/m)	Margin (dB)	Remark
1	2483.500	54.56	-9.20	45.36	74.00	-28.64	peak
2	2494.400	56.59	-9.16	47.43	74.00	-26.57	peak

Note:1.Result (dBuV/m) = Correct Factor (dB/m) + Reading(dBuV).

2.Correction factor (dB/m) = Antenna Factor (dB/m) + Cable loss (dB) – Pre-Amplifier gain (dB).

3.When the peak results are less than average limit, so not need to evaluate the average.



Standard:	FCC Part 15.247	Test Distance:	3 m
Test item:	Band edge	Power:	AC 120 V/60 Hz
Frequency:	2412 MHz	AC 120 V/60 Hz	26(°C)/60% RH
Mode:	Mode 3		
Ant.Polar.:	Horizontal		

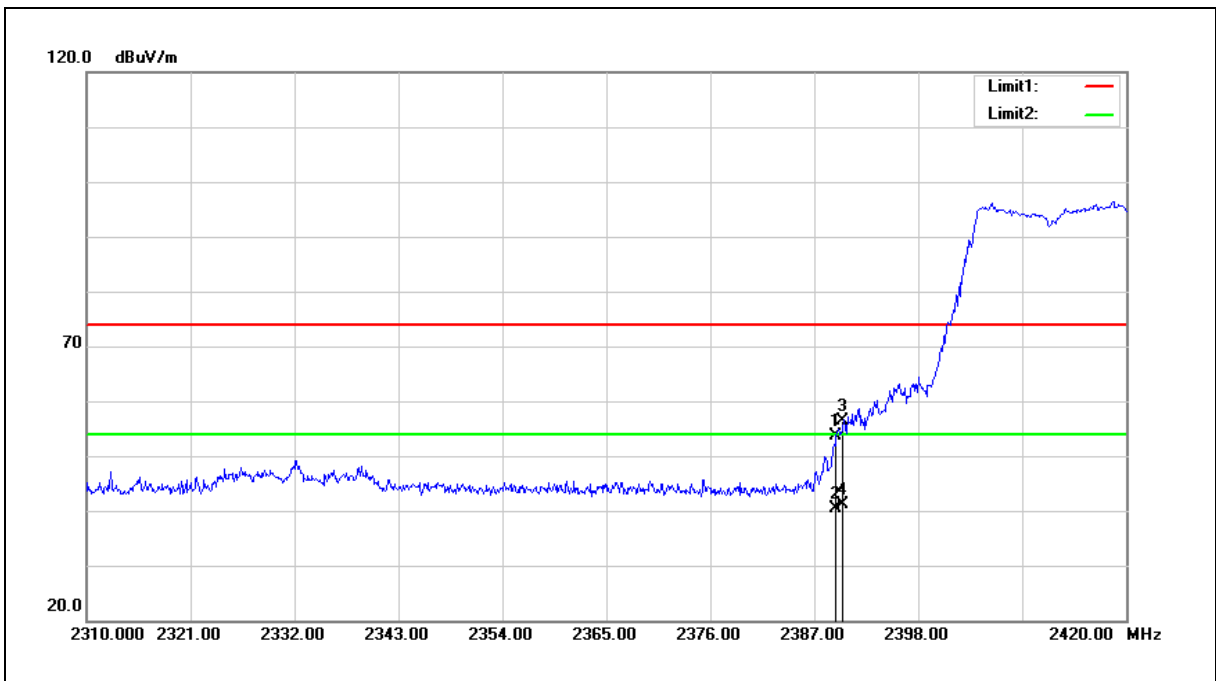

No.	Frequency (MHz)	Reading (dBuV)	Correct Factor (dB/m)	Result (dBuV/m)	Limit (dBuV/m)	Margin (dB)	Remark
1	2389.310	63.24	-9.63	53.61	74.00	-20.39	peak
2	2389.310	50.01	-9.63	40.38	54.00	-13.62	AVG
3	2390.000	66.04	-9.62	56.42	74.00	-17.58	peak
4	2390.000	50.80	-9.62	41.18	54.00	-12.82	AVG

- Note:1.Result (dBuV/m) = Correct Factor (dB/m) + Reading(dBuV).
- 2.Correction factor (dB/m) = Antenna Factor (dB/m) + Cable loss (dB) – Pre-Amplifier gain (dB).
- 3.When the peak results are less than average limit, so not need to evaluate the average.



Standard:	FCC Part 15.247	Test Distance:	3 m
Test item:	Band edge	Power:	AC 120 V/60 Hz
Frequency:	2412 MHz	AC 120 V/60 Hz	26(°C)/60% RH
Mode:	Mode 3		
Ant.Polar.:	Vertical		

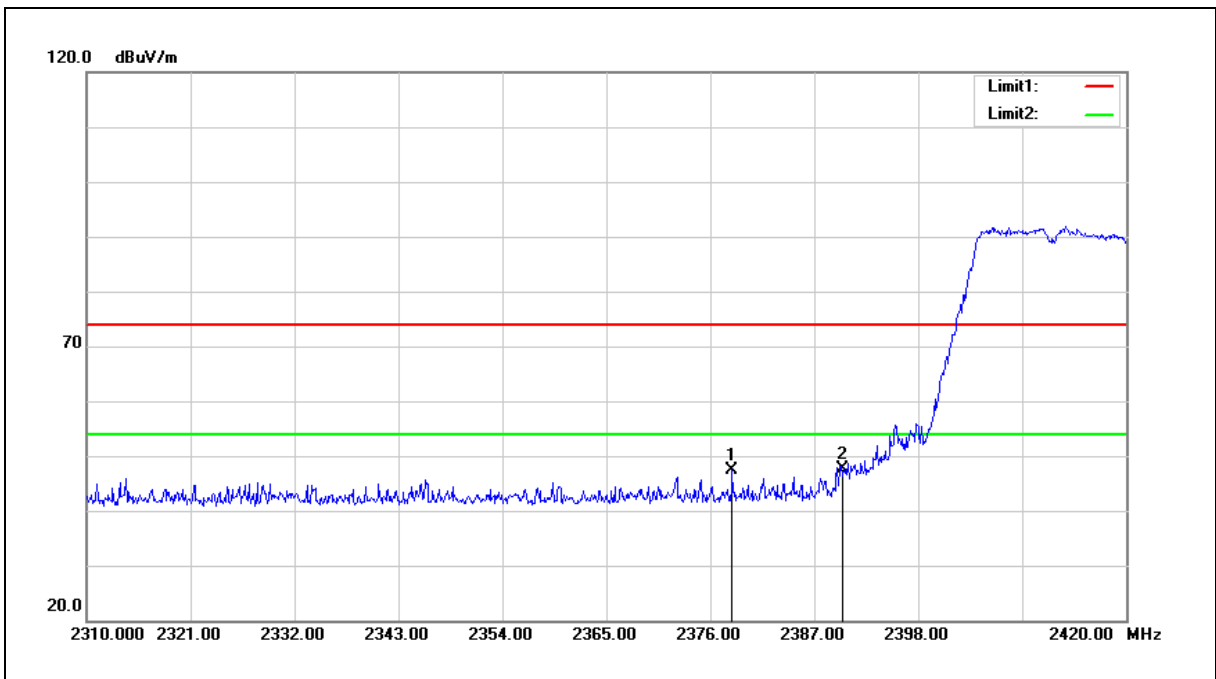

No.	Frequency (MHz)	Reading (dBuV)	Correct Factor (dB/m)	Result (dBuV/m)	Limit (dBuV/m)	Margin (dB)	Remark
1	2378.310	57.12	-9.69	47.43	74.00	-26.57	peak
2	2390.000	57.14	-9.62	47.52	74.00	-26.48	peak

Note:1.Result (dBuV/m) = Correct Factor (dB/m) + Reading(dBuV).

2.Correction factor (dB/m) = Antenna Factor (dB/m) + Cable loss (dB) – Pre-Amplifier gain (dB).

3.When the peak results are less than average limit, so not need to evaluate the average.



Standard:	FCC Part 15.247	Test Distance:	3 m
Test item:	Band edge	Power:	AC 120 V/60 Hz
Frequency:	2462 MHz	AC 120 V/60 Hz	26(°C)/60% RH
Mode:	Mode 3		
Ant.Polar.:	Horizontal		

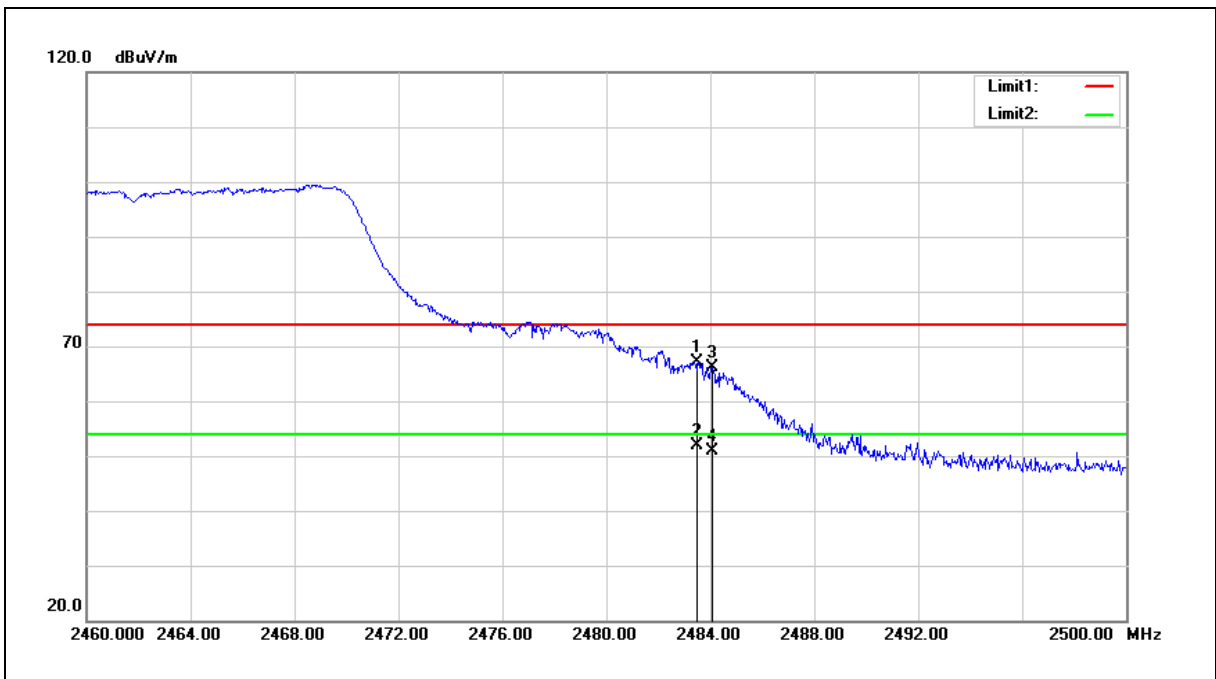

No.	Frequency (MHz)	Reading (dBuV)	Correct Factor (dB/m)	Result (dBuV/m)	Limit (dBuV/m)	Margin (dB)	Remark
1	2483.500	76.41	-9.20	67.21	74.00	-6.79	peak
2	2483.500	61.20	-9.20	52.00	54.00	-2.00	AVG
3	2484.080	75.34	-9.20	66.14	74.00	-7.86	peak
4	2484.080	60.06	-9.20	50.86	54.00	-3.14	AVG

Note:1.Result (dBuV/m) = Correct Factor (dB/m) + Reading(dBuV).
 2.Correction factor (dB/m) = Antenna Factor (dB/m) + Cable loss (dB) – Pre-Amplifier gain (dB).
 3.When the peak results are less than average limit, so not need to evaluate the average.



Standard:	FCC Part 15.247	Test Distance:	3 m
Test item:	Band edge	Power:	AC 120 V/60 Hz
Frequency:	2462 MHz	AC 120 V/60 Hz	26(°C)/60% RH
Mode:	Mode 3		
Ant.Polar.:	Vertical		

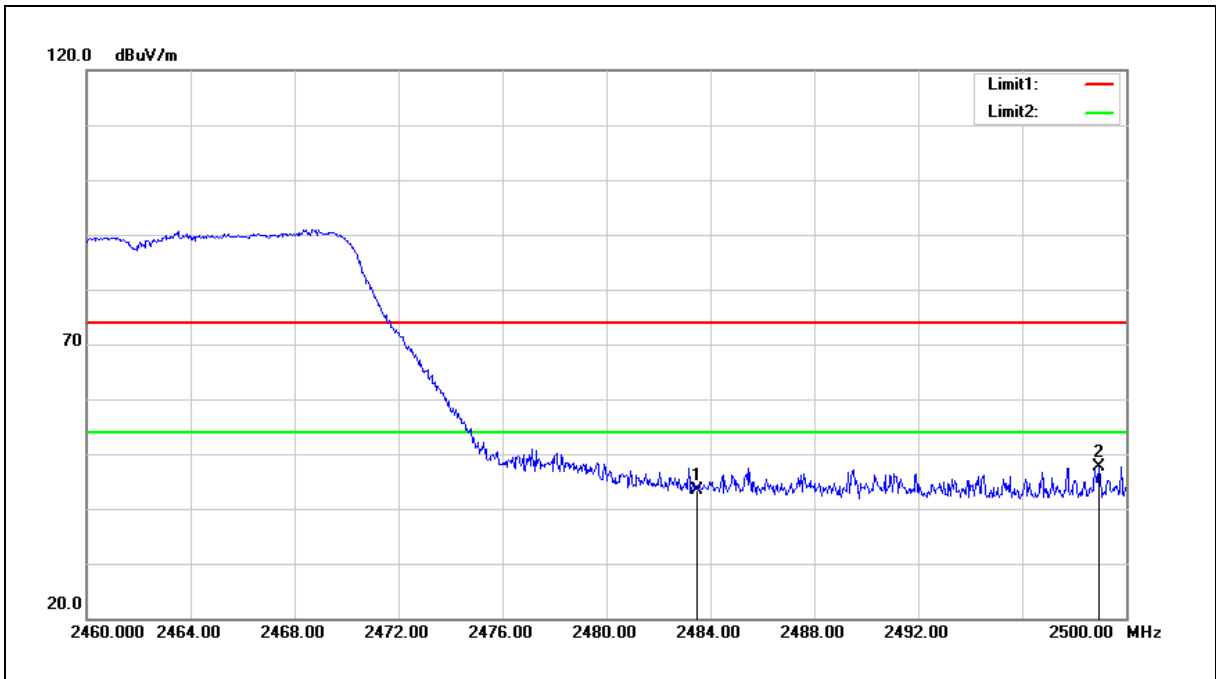

No.	Frequency (MHz)	Reading (dBuV)	Correct Factor (dB/m)	Result (dBuV/m)	Limit (dBuV/m)	Margin (dB)	Remark
1	2483.500	52.57	-9.20	43.37	74.00	-30.63	peak
2	2498.960	56.87	-9.13	47.74	74.00	-26.26	peak

Note:1.Result (dBuV/m) = Correct Factor (dB/m) + Reading(dBuV).

2.Correction factor (dB/m) = Antenna Factor (dB/m) + Cable loss (dB) – Pre-Amplifier gain (dB).

3.When the peak results are less than average limit, so not need to evaluate the average.



Standard:	FCC Part 15.247	Test Distance:	3 m
Test item:	Band edge	Power:	AC 120 V/60 Hz
Frequency:	2412 MHz	AC 120 V/60 Hz	26(°C)/60% RH
Mode:	Mode 4		
Ant.Polar.:	Horizontal		

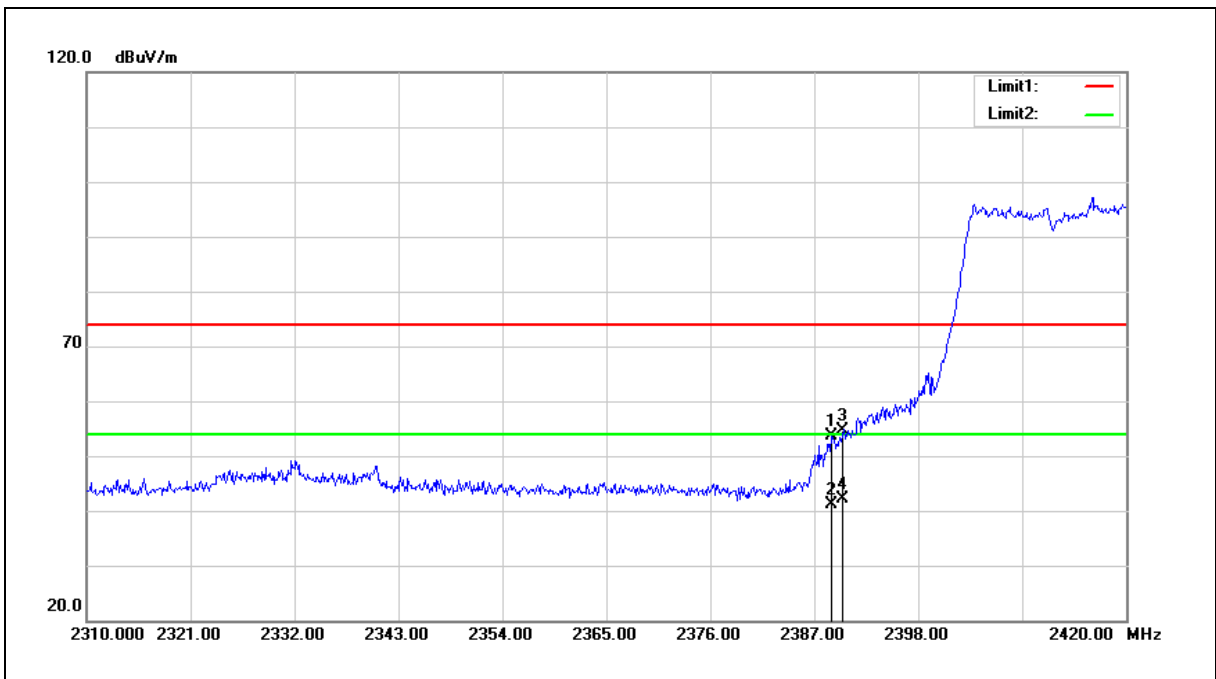

No.	Frequency (MHz)	Reading (dBuV)	Correct Factor (dB/m)	Result (dBuV/m)	Limit (dBuV/m)	Margin (dB)	Remark
1	2388.760	63.21	-9.63	53.58	74.00	-20.42	peak
2	2388.760	50.70	-9.63	41.07	54.00	-12.93	AVG
3	2390.000	64.21	-9.62	54.59	74.00	-19.41	peak
4	2390.000	51.78	-9.62	42.16	54.00	-11.84	AVG

Note:1.Result (dBuV/m) = Correct Factor (dB/m) + Reading(dBuV).

2.Correction factor (dB/m) = Antenna Factor (dB/m) + Cable loss (dB) – Pre-Amplifier gain (dB).

3.When the peak results are less than average limit, so not need to evaluate the average.



Standard:	FCC Part 15.247	Test Distance:	3 m
Test item:	Band edge	Power:	AC 120 V/60 Hz
Frequency:	2412 MHz	AC 120 V/60 Hz	26(°C)/60% RH
Mode:	Mode 4		
Ant.Polar.:	Vertical		

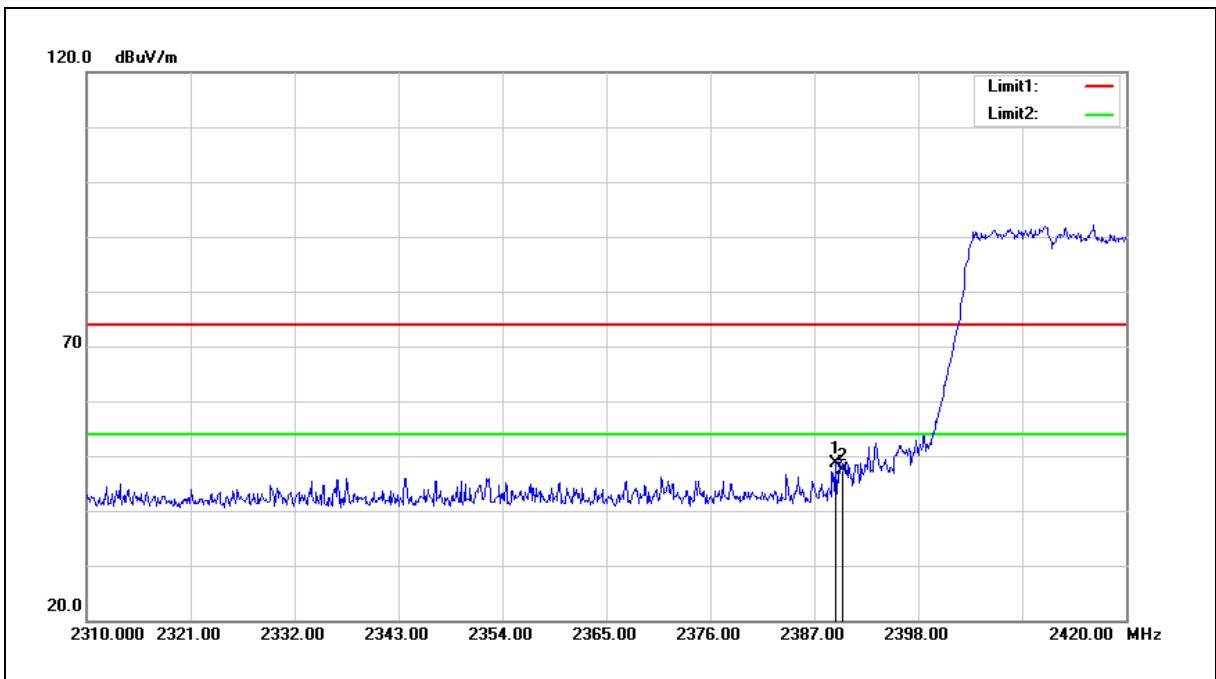

No.	Frequency (MHz)	Reading (dBuV)	Correct Factor (dB/m)	Result (dBuV/m)	Limit (dBuV/m)	Margin (dB)	Remark
1	2389.310	58.24	-9.63	48.61	74.00	-25.39	peak
2	2390.000	56.90	-9.62	47.28	74.00	-26.72	peak

Note:1.Result (dBuV/m) = Correct Factor (dB/m) + Reading(dBuV).

2.Correction factor (dB/m) = Antenna Factor (dB/m) + Cable loss (dB) – Pre-Amplifier gain (dB).

3.When the peak results are less than average limit, so not need to evaluate the average.



Standard:	FCC Part 15.247	Test Distance:	3 m
Test item:	Band edge	Power:	AC 120 V/60 Hz
Frequency:	2462 MHz	AC 120 V/60 Hz	26(°C)/60% RH
Mode:	Mode 4		
Ant.Polar.:	Horizontal		

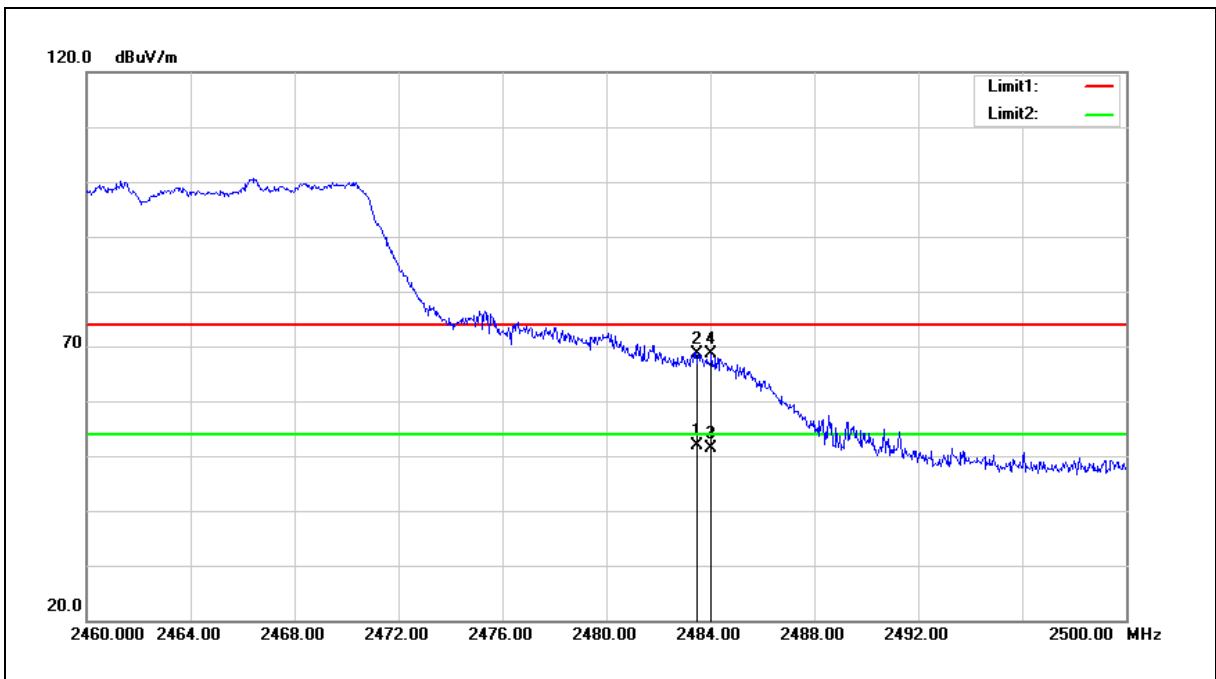

No.	Frequency (MHz)	Reading (dBuV)	Correct Factor (dB/m)	Result (dBuV/m)	Limit (dBuV/m)	Margin (dB)	Remark
1	2483.500	61.16	-9.20	51.96	54.00	-2.04	AVG
2	2483.500	77.90	-9.20	68.70	74.00	-5.30	peak
3	2484.040	60.50	-9.20	51.30	54.00	-2.70	AVG
4	2484.040	77.92	-9.20	68.72	74.00	-5.28	peak

- Note:1.Result (dBuV/m) = Correct Factor (dB/m) + Reading(dBuV).
 2.Correction factor (dB/m) = Antenna Factor (dB/m) + Cable loss (dB) – Pre-Amplifier gain (dB).
 3.When the peak results are less than average limit, so not need to evaluate the average.



Standard:	FCC Part 15.247	Test Distance:	3 m
Test item:	Band edge	Power:	AC 120 V/60 Hz
Frequency:	2462 MHz	AC 120 V/60 Hz	26(°C)/60% RH
Mode:	Mode 4		
Ant.Polar.:	Vertical		

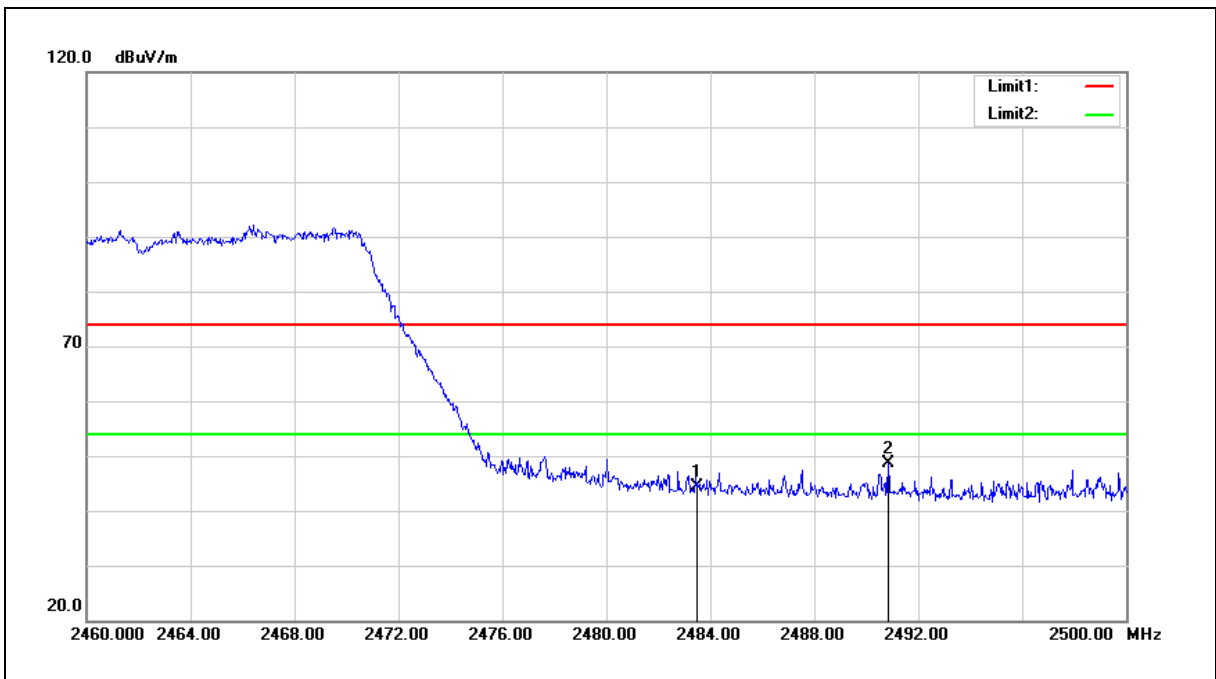

No.	Frequency (MHz)	Reading (dBuV)	Correct Factor (dB/m)	Result (dBuV/m)	Limit (dBuV/m)	Margin (dB)	Remark
1	2483.500	53.48	-9.20	44.28	74.00	-29.72	peak
2	2490.840	57.82	-9.17	48.65	74.00	-25.35	peak

Note:1.Result (dBuV/m) = Correct Factor (dB/m) + Reading(dBuV).

2.Correction factor (dB/m) = Antenna Factor (dB/m) + Cable loss (dB) – Pre-Amplifier gain (dB).

3.When the peak results are less than average limit, so not need to evaluate the average.



Standard:	FCC Part 15.247	Test Distance:	3 m
Test item:	Band edge	Power:	AC 120 V/60 Hz
Frequency:	2422 MHz	AC 120 V/60 Hz	26(°C)/60% RH
Mode:	Mode 5		
Ant.Polar.:	Horizontal		

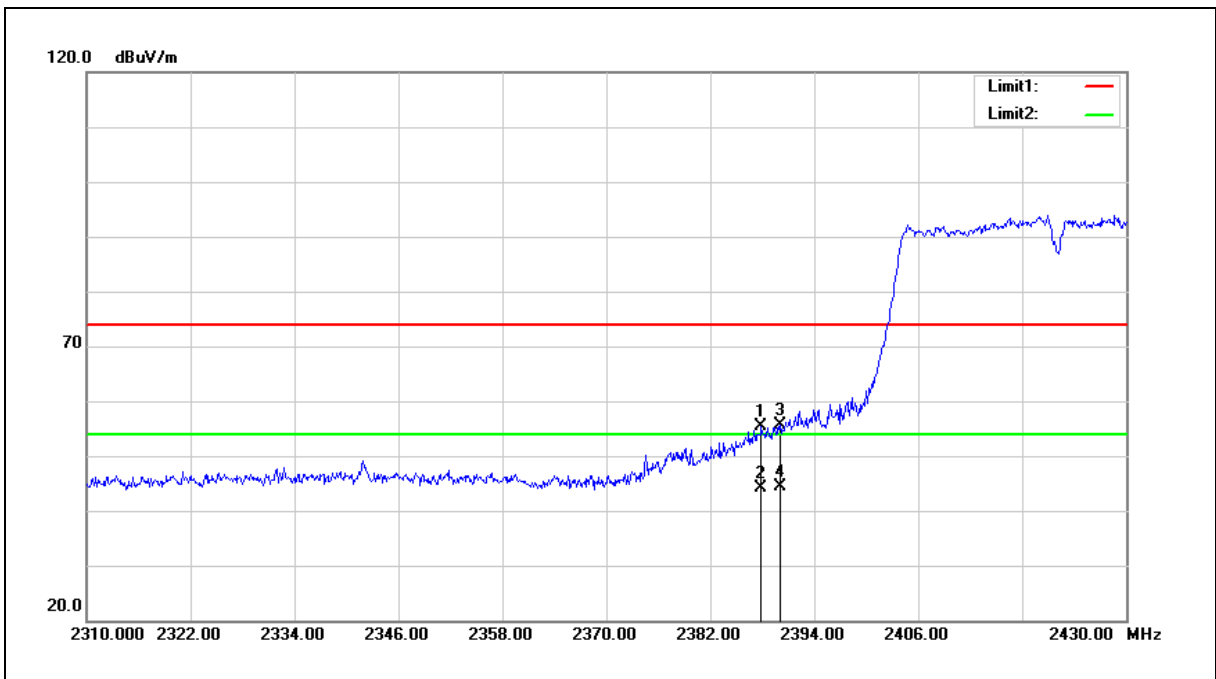

No.	Frequency (MHz)	Reading (dBuV)	Correct Factor (dB/m)	Result (dBuV/m)	Limit (dBuV/m)	Margin (dB)	Remark
1	2387.880	64.94	-9.64	55.30	74.00	-18.70	peak
2	2387.880	53.77	-9.64	44.13	54.00	-9.87	AVG
3	2390.000	65.15	-9.62	55.53	74.00	-18.47	peak
4	2390.000	53.90	-9.62	44.28	54.00	-9.72	AVG

Note:1.Result (dBuV/m) = Correct Factor (dB/m) + Reading(dBuV).

2.Correction factor (dB/m) = Antenna Factor (dB/m) + Cable loss (dB) – Pre-Amplifier gain (dB).

3.When the peak results are less than average limit, so not need to evaluate the average.



Standard:	FCC Part 15.247	Test Distance:	3 m
Test item:	Band edge	Power:	AC 120 V/60 Hz
Frequency:	2422 MHz	AC 120 V/60 Hz	26(°C)/60% RH
Mode:	Mode 5		
Ant.Polar.:	Vertical		

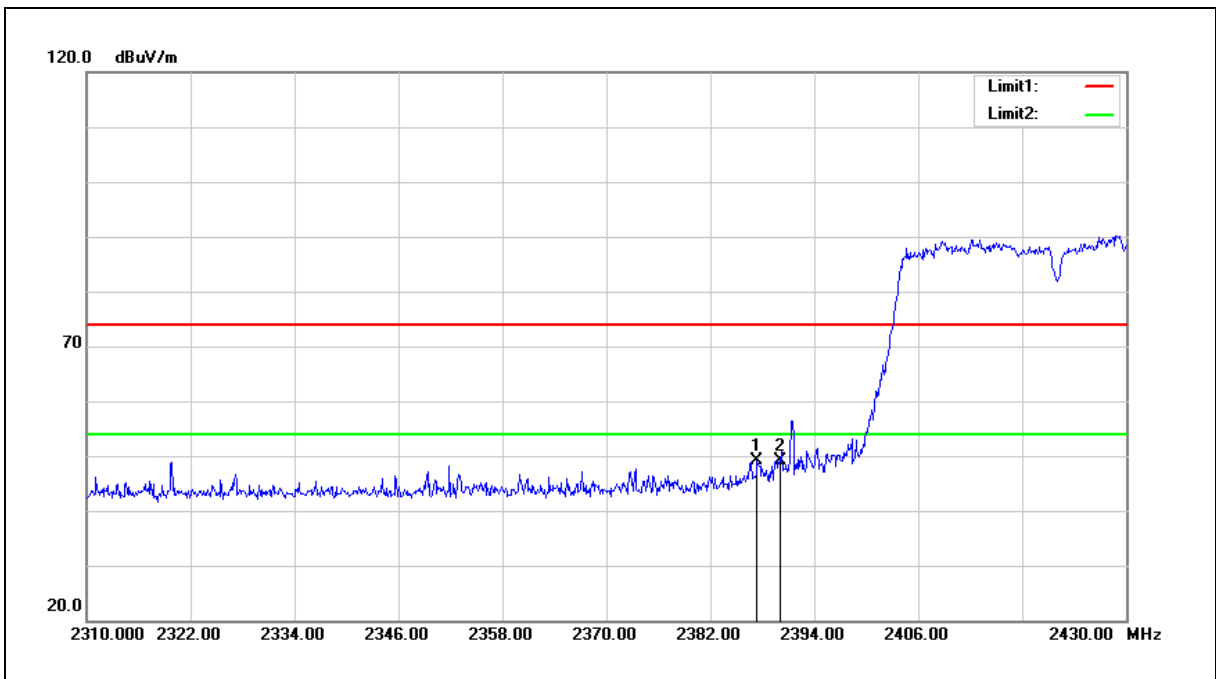

No.	Frequency (MHz)	Reading (dBuV)	Correct Factor (dB/m)	Result (dBuV/m)	Limit (dBuV/m)	Margin (dB)	Remark
1	2387.400	58.79	-9.64	49.15	74.00	-24.85	peak
2	2390.000	58.81	-9.62	49.19	74.00	-24.81	peak

Note:1.Result (dBuV/m) = Correct Factor (dB/m) + Reading(dBuV).

2.Correction factor (dB/m) = Antenna Factor (dB/m) + Cable loss (dB) – Pre-Amplifier gain (dB).

3.When the peak results are less than average limit, so not need to evaluate the average.



Standard:	FCC Part 15.247	Test Distance:	3 m
Test item:	Band edge	Power:	AC 120 V/60 Hz
Frequency:	2452 MHz	AC 120 V/60 Hz	26(°C)/60% RH
Mode:	Mode 5		
Ant.Polar.:	Horizontal		

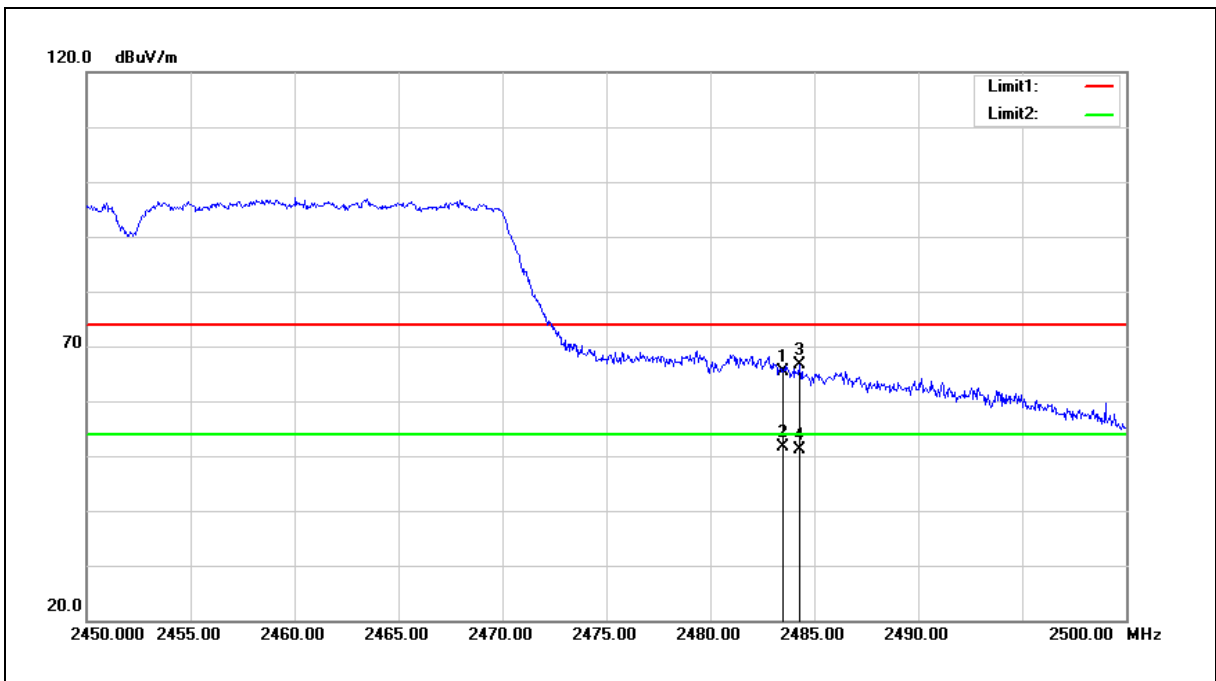

No.	Frequency (MHz)	Reading (dBuV)	Correct Factor (dB/m)	Result (dBuV/m)	Limit (dBuV/m)	Margin (dB)	Remark
1	2483.500	74.58	-9.20	65.38	74.00	-8.62	peak
2	2483.500	60.87	-9.20	51.67	54.00	-2.33	AVG
3	2484.300	75.81	-9.20	66.61	74.00	-7.39	peak
4	2484.300	60.38	-9.20	51.18	54.00	-2.82	AVG

- Note:1.Result (dBuV/m) = Correct Factor (dB/m) + Reading(dBuV).
- 2.Correction factor (dB/m) = Antenna Factor (dB/m) + Cable loss (dB) – Pre-Amplifier gain (dB).
- 3.When the peak results are less than average limit, so not need to evaluate the average.



Standard:	FCC Part 15.247	Test Distance:	3 m
Test item:	Band edge	Power:	AC 120 V/60 Hz
Frequency:	2452 MHz	AC 120 V/60 Hz	26(°C)/60% RH
Mode:	Mode 5		
Ant.Polar.:	Vertical		

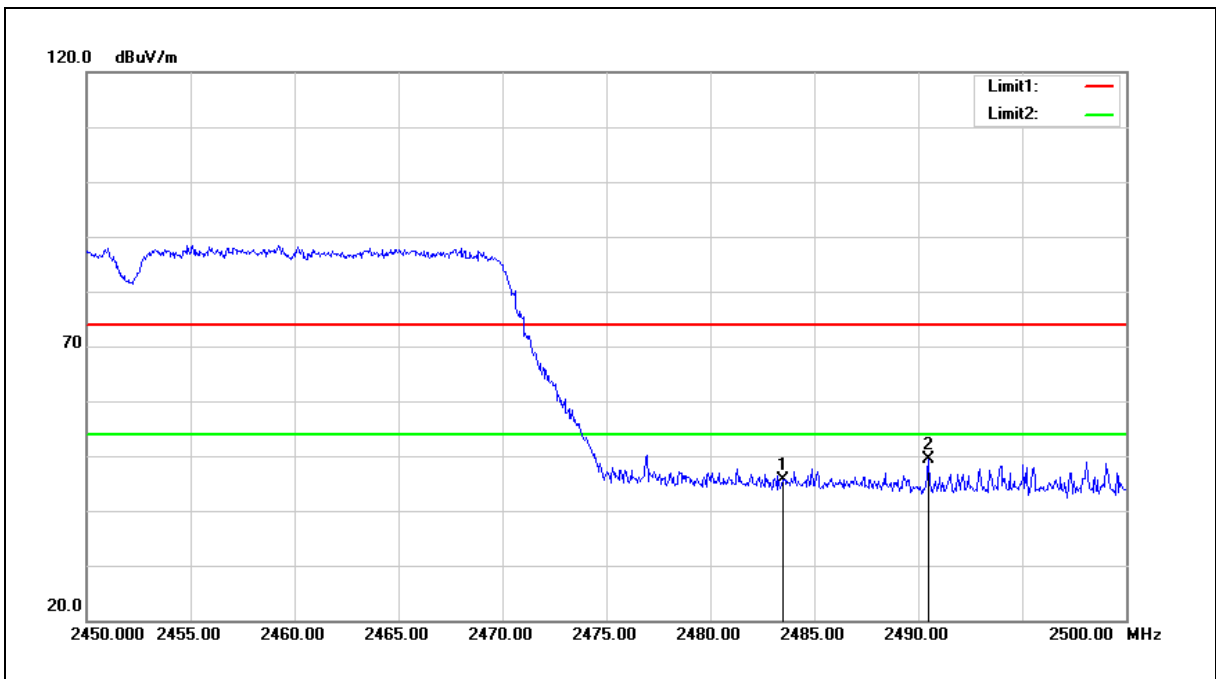

No.	Frequency (MHz)	Reading (dBuV)	Correct Factor (dB/m)	Result (dBuV/m)	Limit (dBuV/m)	Margin (dB)	Remark
1	2483.500	54.77	-9.20	45.57	74.00	-28.43	peak
2	2490.500	58.50	-9.17	49.33	74.00	-24.67	peak

Note:1.Result (dBuV/m) = Correct Factor (dB/m) + Reading(dBuV).

2.Correction factor (dB/m) = Antenna Factor (dB/m) + Cable loss (dB) – Pre-Amplifier gain (dB).

3.When the peak results are less than average limit, so not need to evaluate the average.