

Test Report

FCC ID: 2AF7ECIRCLE2

Date of issue: Apr. 25, 2018

Report Number:	MTi180424E087
Sample Description:	Circle
Model(s):	Circle2
Applicant:	Circle Media Inc.
Address:	1319 SE Martin Luther King Jr. Blvd. Suite 210 Portland, OR 97214, USA
Date of Test:	Mar, 22. 2018 – Apr, 25. 2018

Shenzhen Microtest Co., Ltd.
<http://www.mtitest.com>

Table of Contents

1	GENERAL INFORMATION	4
1.1	DESCRIPTION OF EUT	4
1.2	OPERATION CHANNEL LIST	5
1.3	TEST CHANNEL LIST	5
1.4	ANCILLARY EQUIPMENT LIST	5
1.5	DESCRIPTION OF SUPPORT UNITS	5
2	SUMMARY OF TEST RESULTS	7
3	TEST FACILITIES AND ACCREDITATIONS	8
3.1	TEST LABORATORY	8
3.2	ENVIRONMENTAL CONDITIONS	8
3.3	MEASUREMENT UNCERTAINTY	8
3.4	TEST SOFTWARE	8
4	EQUIPMENT LIST	9
5	TEST RESULT	10
5.1	ANTENNA REQUIREMENT	10
5.1.1	Standard requirement	10
5.1.2	EUT Antenna	10
5.2	PEAK OUTPUT POWER	11
5.2.1	Limit	11
5.2.2	Test setup	11
5.2.3	Test procedure	11
5.2.4	Test results	12
5.3	POWER SPECTRAL DENSITY	13
5.3.1	Limit	13
5.3.2	Test Setup	13
5.3.3	Test Procedure	13
5.3.4	Test Results	14
5.4	CONDUCTED EMISSION	22
5.4.1	Limits	22
5.4.2	Test setup	22
5.4.3	Test procedure	23
5.4.4	Test results	24
5.5	RADIATED SPURIOUS	26
5.5.1	Limits	26
5.5.2	Test setup	27
5.5.3	Test procedure	28
5.5.4	Test results	29
5.5.4.1	Radiation emission	29
5.5.4.2	Band edge - radiated	40
5.6	CONDUCTION SPURIOUS EMISSION	41
5.6.1	Limits	41
5.6.2	Test setup	41
5.6.3	Test procedure	41
5.6.4	Test results	42
5.7	6DB BANDWIDTH	46
5.7.1	Limit	46
5.7.2	Test setup	46
5.7.3	Test procedure	46
5.7.4	Test results	47
	PHOTOGRAPHS OF THE TEST SETUP	55

This test report is valid for the tested samples only. It cannot be reproduced except in full without prior written consent of Shenzhen Microtest Co., Ltd.

Test Result Certification

Applicant's name: Circle Media Inc.
Address: 1319 SE Martin Luther King Jr. Blvd. Suite 210 Portland, OR 97214, USA

Manufacture's Name: Circle Media Inc.
Address: 1319 SE Martin Luther King Jr. Blvd. Suite 210 Portland, OR 97214, USA

Product name: Circle

Trademark: Circle

Model name: Circle2

Serial Model: N/A

Standards: FCC Part 15.247
ANSI C63.10-2013

Test Procedure: KDB558074 D01 v04
KDB662911 D01 v02r01

This device described above has been tested by Shenzhen Microtest Co., Ltd. and the test results show that the equipment under test (EUT) compliance with the FCC requirements. And it is applicable only to the tested sample identified in the report.

Tested by:



Demi Mu

Apr. 25, 2018

Reviewed by:



Blue Zheng

Apr. 25, 2018

Approved by:



Smith Chen

Apr. 25, 2018

This test report is valid for the tested samples only. It cannot be reproduced except in full without prior written consent of Shenzhen Microtest Co., Ltd.

1 General information

1.1 Description of EUT

Product name	Circle
Model name	Circle2
Serial Model	N/A
Model difference:	N/A
Operation Frequency	802.11b/g/n20:2412~2462 MHz 802.11n40:2422~2452 MHz
Modulation Type:	11b: DQPSK, DBPSK, DSSS, CCK 11g: BPSK, QPSK, 16QAM, 64QAM, OFDM 11n: BPSK, QPSK, 16QAM, 64QAM with OFDM
Bit Rate of Transmitter	802.11b:11/5.5/2/1 Mbps 802.11g:54/48/36/24/18/12/9/6Mbps 802.11n:65/52/6.5Mbps
Antenna Type	FPCB antenna
Antenna Gain (dBi)	For 802.11b/g, working in SISO mode, then the antenna gain as below: 802.11b/g: Antenna A :5dBi 802.11b/g: Antenna B :5dBi
	For 802.11n, working in MIMO mode, the antenna gains should be calculated by the formula: Directional Gain = $G_{ANT} + 10 \cdot \log(N_{ANT})$ dBi $= 5 \text{ dBi} + 10 \cdot \log(2) \text{ dBi} = 8.01 \text{ dBi}$
Max. Output Power:	22.07dBm
Hardware Version:	V2
Software Version:	1.1.2
Power Supply:	DC 5V from AC adapter 230V/50Hz
Battery information:	DC3.7V by battery
Adapter information:	Model:KA1517-0502000USU Input:100-240V AC50/60Hz 0.35A Max Output:5V 2000mA

This test report is valid for the tested samples only. It cannot be reproduced except in full without prior written consent of Shenzhen Microtest Co., Ltd.

1.2 Operation channel list

Channel List for 802.11b/g/n(20)

Channel	Frequency (MHz)	Channel	Frequency (MHz)
01	2412	07	2442
02	2417	08	2447
03	2422	09	2452
04	2427	10	2457
05	2432	11	2462
06	2437	\	\

Channel List for 802.11n(40)

Channel	Frequency (MHz)	Channel	Frequency (MHz)
03	2422	07	2442
04	2427	08	2447
05	2432	09	2452
06	2437	\	\

1.3 Test channel list

Channel List for 802.11b/g/n(20)

Channel	Channel	Frequency (MHz)
Low	01	2412
Middle	06	2437
High	11	2462

Channel List for 802.11n(40)

Channel	Channel	Frequency (MHz)
Low	03	2422
Middle	06	2437
High	09	2452

1.4 Ancillary equipment list

Equipment	Model	S/N	Manufacturer	Certificate type
/	/	/	/	/

1.5 Description of Support Units

The EUT has been tested as an independent unit together with other necessary accessories or support units. The following support units or accessories were used to form a representative test configuration during the tests.

Item	Equipment	Brand	Model/Type No.	Series No.	Note
EUT	Adapter	/	KA1517-0502000USU	/	/

This test report is valid for the tested samples only. It cannot be reproduced except in full without prior written consent of Shenzhen Microtest Co., Ltd.

Note:

- (1) The support equipment was authorized by Declaration of Confirmation.
- (2) For detachable type I/O cable should be specified the length in cm in 『Length』 column.

2 Summary of Test Results

Test procedures according to the technical standards:

No.	Standard Section	Test Item	Result	Remark
1	15.203	Antenna Requirement	Pass	
2	15.247 (b)	Peak Output Power	Pass	
3	15.247 (d)	Power Spectral Density	Pass	
4	15.207	Conducted Emission	Pass	
5	15.247 (c)	Radiated Spurious Emission	Pass	
6	15.205	Band Edge Emission	Pass	
7	15.247 (a)(2)	6dB Bandwidth	Pass	

This test report is valid for the tested samples only. It cannot be reproduced except in full without prior written consent of Shenzhen Microtest Co., Ltd.

3 Test Facilities and Accreditations

3.1 Test laboratory

Test Laboratory	Shenzhen Microtest Co., Ltd
Location	No.102A & 302A, East Block, Hengfang Industrial Park, Xingye Road, Xixiang, Bao'an District, Shenzhen, Guangdong, China
FCC Registration No.:	448573

3.2 Environmental conditions

Temperature:	20°C~30°C
Humidity	30%~70%
Atmospheric pressure	98kPa~101kPa

3.3 Measurement uncertainty

The reported uncertainty of measurement $y \pm U$ where expanded uncertainty U is based on a standard uncertainty multiplied by a coverage factor of $k=2$ providing a level of confidence of approximately 95 %

No.	Item	Uncertainty
1	Conducted Emission Test	$\pm 1.38\text{dB}$
2	RF power, conducted	$\pm 0.16\text{dB}$
3	Spurious emissions, conducted	$\pm 0.21\text{dB}$
4	All emissions, radiated(<1G)	$\pm 4.68\text{dB}$
5	All emissions, radiated(>1G)	$\pm 4.89\text{dB}$
6	Temperature	$\pm 0.5^\circ\text{C}$
7	Humidity	$\pm 2\%$

3.4 Test software

Software Name	Manufacturer	Model	Version
RF Test System	Farad	LZ-RF	Lz_Rf 3A3

This test report is valid for the tested samples only. It cannot be reproduced except in full without prior written consent of Shenzhen Microtest Co., Ltd.

4 Equipment list

Equipment No.	Equipment Name	Manufacturer	Model	Serial No.	Calibration date	Due date
MTI-E001	Spectrum Analyzer	Agilent	E4407B	MY41441082	2017/09/18	2018/09/17
MTI-E002	CMU 200 universal radio communication tester	Rohde&schwarz	CMU 200	114587	2017/09/18	2018/09/17
MTI-E004	EMI Test Receiver	Rohde&schwarz	ESPI	1000314	2017/09/18	2018/09/17
MTI-E006	Broadband antenna	schwarabeck	VULB9163	872	2017/09/18	2018/09/17
MTI-E007	Horn antenna	schwarabeck	BBHA9120D	1201	2017/09/18	2018/09/17
MTI-E014	amplifier	America	8447D	3113A06150	2017/09/18	2018/09/17
MTI-E015	Conduction Immunity Signal Generator	Schloder	CDG6000	126A1343/2015	2017/09/18	2018/09/17
MTI-E016	Coupled decoupling network	Schloder	CDA M2/M3	A2210332/2015	2017/09/18	2018/09/17
MTI-E032	Comprehensive test instrument	Rohde&schwarz	CMW500	124192	2017/09/13	2018/09/12
MTI-E034	amplifier	Agilent	8449B	3008A02400	2017/08/22	2018/08/21
MTI-E040	Spectrum analyzer	Agilent	N9020A	MY49100060	2017/09/04	2018/09/04
MTI-E041	Signal generator	Agilent	N5182A	MY49060455	2017/09/22	2018/09/22
MTI-E042	Analog signal generator	Agilent	E4421B	GB40051240	2017/09/22	2018/09/22
MTI-E043	Power probe	Dare Instruments	RPR3006W	16I00054SN016	2017/09/28	2018/09/28
MTI-E047	10dB attenuator	Mini-Circuits	UNAT-10+	15542	2017/09/23	2018/09/23
MTI-E049	spectrum analyzer	Rohde&schwarz	FSP-38	100019	2017/09/18	2018/09/17
MTI-E050	PSG Signal generator	Agilent	E8257D	MY46520873	2017/09/24	2018/09/23
MTI-E051	Active Loop Antenna 9kHz - 30MHz	Schwarzbeek	FMZB 1519 B	00044	2017//9/26	2018/09/25
MTI-E052	18-40GHz amplifier	Chengdu step Micro Technology	ZLNA-18-40G-21	1608001	2017/09/18	2018/09/17
MTI-E053	15-40G Antenna	Schwarzbeek	BBHA9170	BBHA9170582	2017/09/18	2018/09/17

Note: the calibration interval of the above test instruments is 12 months and the calibrations are traceable to international system unit (SI).

This test report is valid for the tested samples only. It cannot be reproduced except in full without prior written consent of Shenzhen Microtest Co., Ltd.

5 Test Result

5.1 Antenna requirement

5.1.1 Standard requirement

15.203 requirement: For intentional device, according to 15.203: an intentional radiator shall be designed to ensure that no antenna other than that furnished by the responsible party shall be used with the device

5.1.2 EUT Antenna

The EUT antenna is FPCB antenna. It comply with the standard requirement. In case of replacement of broken antenna the same antenna type must be used.

5.2 Peak output power

5.2.1 Limit

FCC Part15 Subpart C				
Section	Test Item	Limit	Frequency Range (MHz)	Result
15.247(b)(3)	Peak output power	1 watt or 30dBm	2400-2483.5	PASS

5.2.2 Test setup

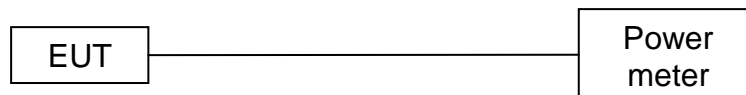

5.2.3 Test procedure

The EUT was directly connected to the Power meter.

5.2.4 Test results

802.11b

Test Channel	Frequency (MHz)	Output Power (ANT A)		Output Power (ANT B)		Limit (dBm)	
		dBm	mW	dBm	mW	dBm	mW
CH01	2412	15.33	34.12	13.53	22.54	30	1000
CH06	2437	15.18	32.96	14.23	26.49		
CH11	2462	15.26	33.57	13.92	24.66		

802.11g

Test Channel	Frequency (MHz)	Output Power (ANT A)		Output Power (ANT B)		Limit (dBm)	
		dBm	mW	dBm	mW	dBm	mW
CH01	2412	16.38	43.45	15.16	32.81	30	1000
CH06	2437	16.42	43.85	15.24	33.42		
CH11	2462	16.51	44.77	15.12	32.51		

802.11n20

Test Channel	Frequency (MHz)	Output Power (ANT A)		Output Power (ANT B)		Total Power (ANT A + ANT B)		Limit (dBm)	
		dBm	mW	dBm	mW	dBm	mW	dBm	mW
CH01	2412	18.62	72.78	18.67	73.62	21.66	146.40	27.99	1000
CH06	2437	18.49	70.63	19.57	90.57	22.07	161.21		
CH11	2462	18.54	71.45	18.95	78.52	21.76	149.97		

Note: if transmitting antennas of directional gain greater than 6 dBi are used, then the limit should be reduced. Because the directional gain = 8.01dB > 6.0 dBi, the limit should be calculated as below:

$$\text{Limit} = 30 \text{ dBm} - (\text{ANT Gain} + 10 \cdot \text{Log}(N=2) - 6 \text{ dBi})$$

$$= 30 \text{ dBm} - (5 + 3.01 - 6) \text{ dBi} = 27.99 \text{ dBm}$$

802.11n40

Test Channel	Frequency (MHz)	Output Power (ANT A)		Output Power (ANT B)		Total Power (ANT A + ANT B)		Limit (dBm)	
		dBm	mW	dBm	mW	dBm	mW	dBm	mW
CH03	2422	17.07	50.93	16.42	43.85	19.77	94.79	27.99	1000
CH06	2437	17.29	53.58	17.21	52.60	20.26	106.18		
CH09	2452	17.71	59.02	17.74	59.43	20.74	118.45		

Note: if transmitting antennas of directional gain greater than 6 dBi are used, then the limit should be reduced. Because the directional gain = 8.01dB > 6.0 dBi, the limit should be calculated as below:

$$\text{Limit} = 30 \text{ dBm} - (\text{ANT Gain} + 10 \cdot \text{Log}(N=2) - 6 \text{ dBi})$$

$$= 30 \text{ dBm} - (5 + 3.01 - 6) \text{ dBi} = 27.99 \text{ dBm}$$

5.3 Power spectral density

5.3.1 Limit

FCC Part15 Subpart C				
Section	Test Item	Limit	Frequency Range (MHz)	Result
15.247	Power Spectral Density	8 dBm (in any 3KHz)	2400-2483.5	Pass

5.3.2 Test Setup

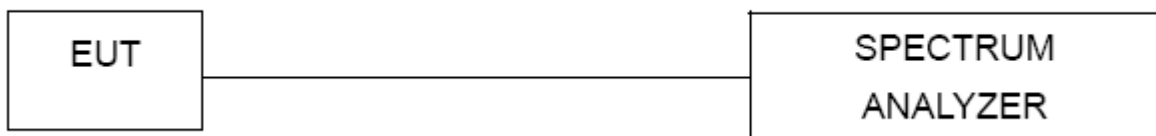

5.3.3 Test Procedure

- a. The EUT tested system was configured as the statements of 2.1 Unless otherwise a special operating condition is specified in the follows during the testing.
- b. Set analyzer center frequency to DTS channel center frequency.
- c. Set the span to 1.5 times the DTS channel bandwidth.
- d. Set the RBW ≥ 3 kHz.
- e. Set the VBW $\geq 3 \times$ RBW.
- f. Detector = peak.
- g. Sweep time = auto couple.
- h. Trace mode = max hold.
- i. Allow trace to fully stabilize.
- j. Use the peak marker function to determine the maximum amplitude level.
- k. If measured value exceeds limit, reduce RBW (no less than 3 kHz) and repeat.

This test report is valid for the tested samples only. It cannot be reproduced except in full without prior written consent of Shenzhen Microtest Co., Ltd.

5.3.4 Test Results

802.11b

ANT A:

Test Channel	Frequency (MHz)	Power Density (dBm/3kHz)	Limit (dBm/3kHz)	Result
CH01	2412	-11.059	8	Pass
CH06	2437	-10.615	8	Pass
CH11	2462	-11.694	8	Pass



This test report is valid for the tested samples only. It cannot be reproduced except in full without prior written consent of Shenzhen Microtest Co., Ltd.

ANT B:

Test Channel	Frequency (MHz)	Power Density (dBm/3kHz)	Limit (dBm/3kHz)	Result
CH01	2412	-13.810	8	Pass
CH06	2437	-11.491	8	Pass
CH11	2462	-11.413	8	Pass

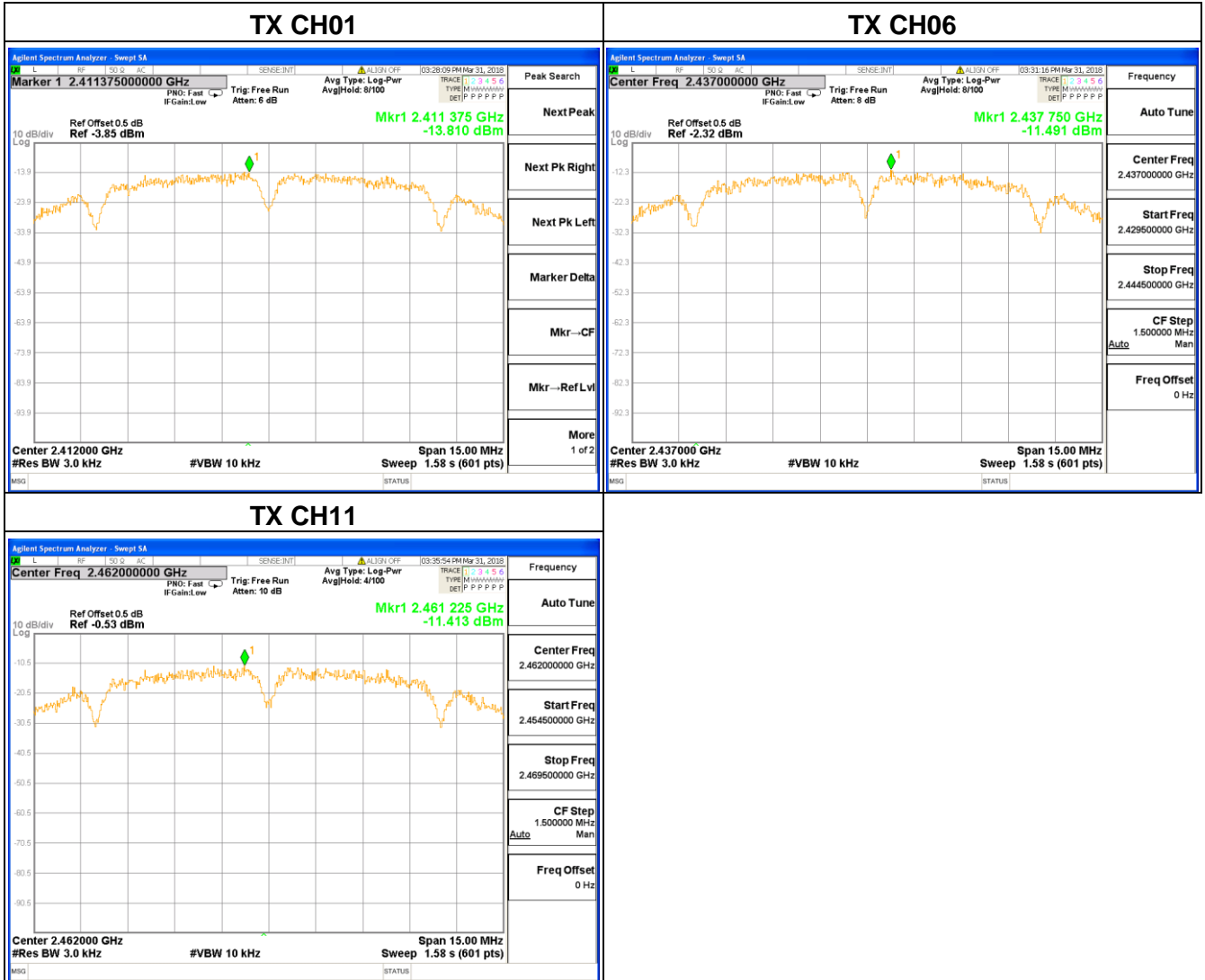

This test report is valid for the tested samples only. It cannot be reproduced except in full without prior written consent of Shenzhen Microtest Co., Ltd.

802.11g

ANT A:

Test Channel	Frequency (MHz)	Power Density (dBm/3kHz)	Limit (dBm/3kHz)	Result
CH01	2412	-15.195	8	Pass
CH06	2437	-14.199	8	Pass
CH11	2462	-14.243	8	Pass

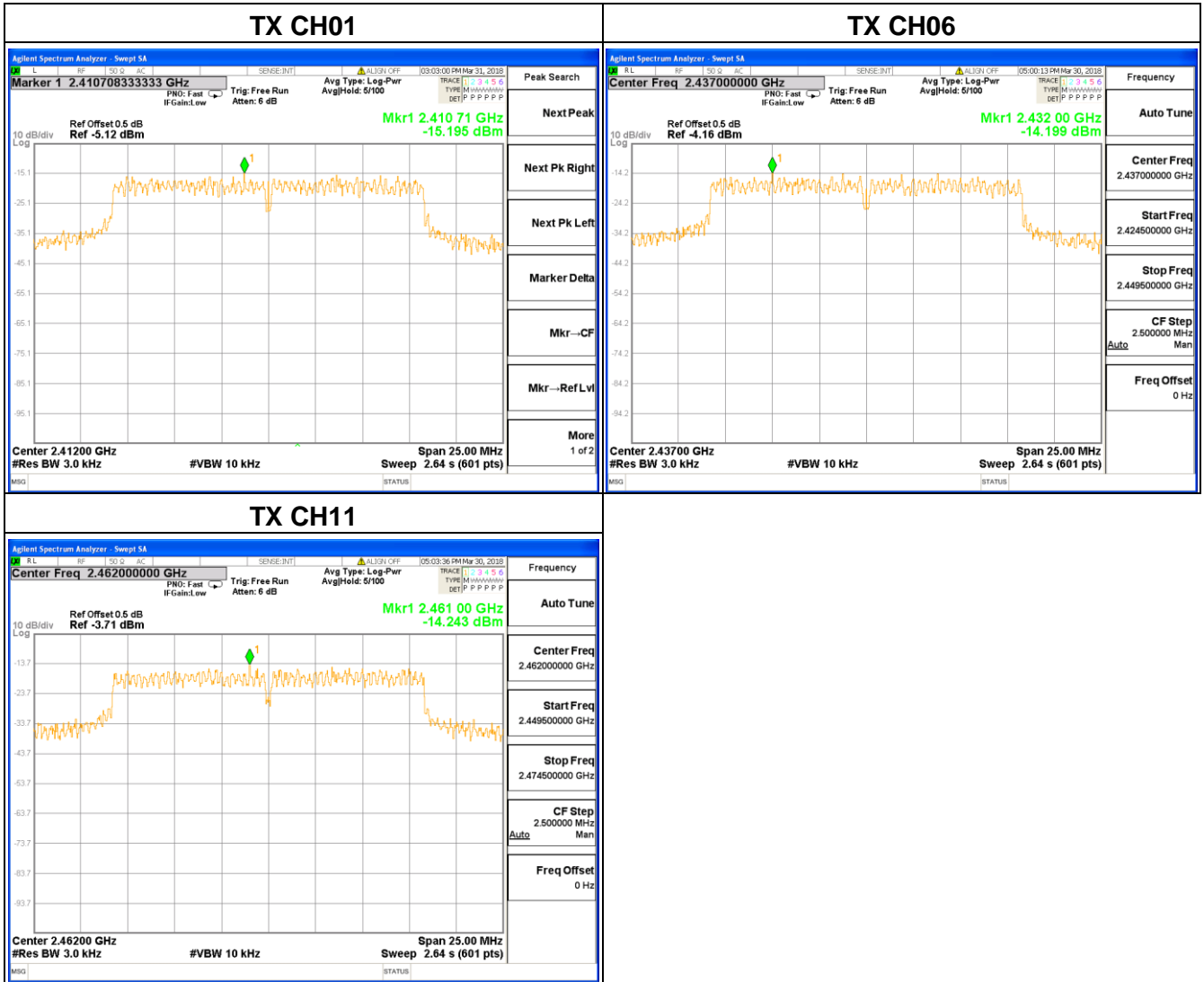

This test report is valid for the tested samples only. It cannot be reproduced except in full without prior written consent of Shenzhen Microtest Co., Ltd.

ANT B:

Test Channel	Frequency (MHz)	Power Density (dBm/3kHz)	Limit (dBm/3kHz)	Result
CH01	2412	-15.196	8	Pass
CH06	2437	-13.917	8	Pass
CH11	2462	-12.329	8	Pass

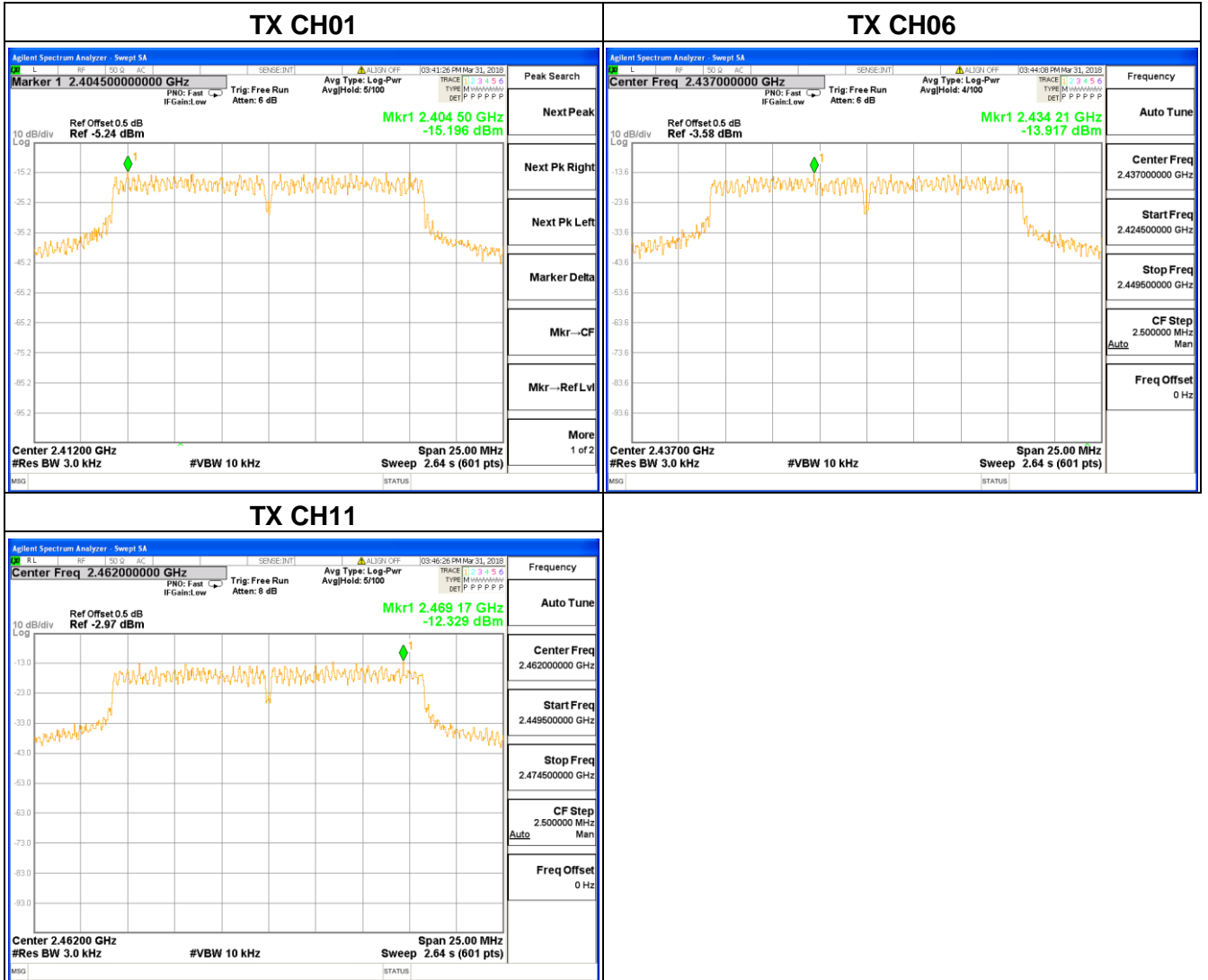

This test report is valid for the tested samples only. It cannot be reproduced except in full without prior written consent of Shenzhen Microtest Co., Ltd.

802.11n20

ANT A+ANT B

Test Channel	Frequency (MHz)	Power Density of ANT A (dBm/3kHz)	Power Density of ANT B (dBm/3kHz)	Total Power Density of (ANT A + ANT B) (dBm/3kHz)	Limit (dBm/3kHz)	Result
CH01	2412	-16.001	-13.930	-11.83	5.99	Pass
CH06	2437	-14.895	-13.832	-11.32	5.99	Pass
CH11	2462	-14.626	-13.828	-11.20	5.99	Pass

Note: if transmitting antennas of directional gain greater than 6 dBi are used, then the limit should be reduced.

Because the directional gain = 8.01dB > 6.0 dBi, the limit should be calculated as below:

*Limit = 8 dBm/3kHz - (ANT Gain + 10*Log(N=2) - 6dBi)*

= 8 dBm/3kHz - (5 + 3.01 - 6) dBi = 5.99 dBm/3kHz

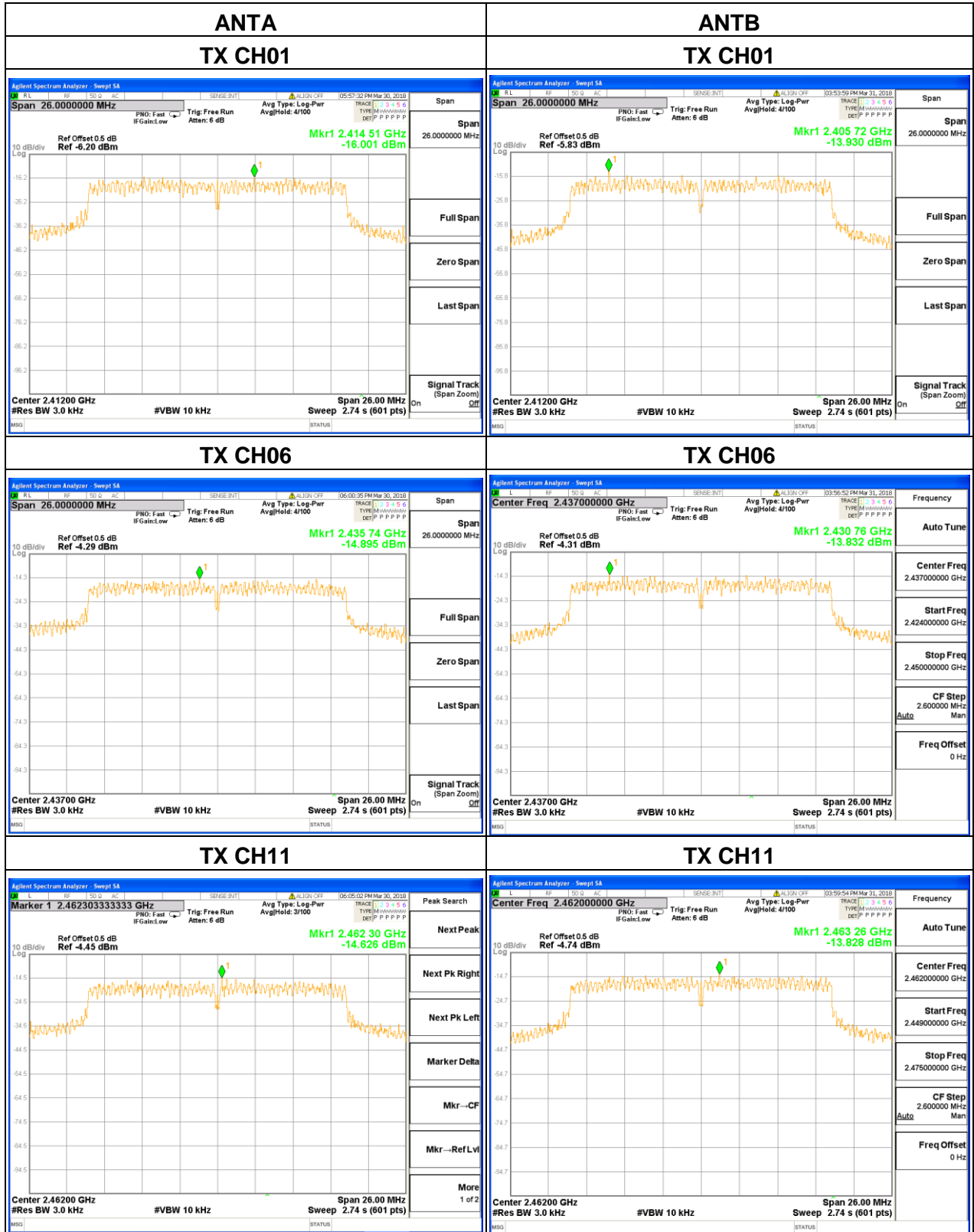

This test report is valid for the tested samples only. It cannot be reproduced except in full without prior written consent of Shenzhen Microtest Co., Ltd.

802.11n40

Test Channel	Frequency (MHz)	Power Density of ANTA (dBm/3kHz)	Power Density of ANTB (dBm/3kHz)	Total Power Density of (ANTA + ANTB) (dBm/3kHz)	Limit (dBm/3kHz)	Result
CH03	2422	-18.604	-17.781	-15.16	6	Pass
CH06	2437	-17.282	-16.686	-13.96	6	Pass
CH09	2452	-17.577	-15.700	-13.53	6	Pass

Note: if transmitting antennas of directional gain greater than 6 dBi are used, then the limit should be reduced.

Because the directional gain = 8.01dB > 6.0 dBi, the limit should be calculated as below:

*Limit = 8 dBm/3kHz - (ANT Gain + 10*Log(N=2) - 6dBi)*

= 8 dBm/3kHz - (5 + 3.01 - 6) dBi = 5.99 dBm/3kHz

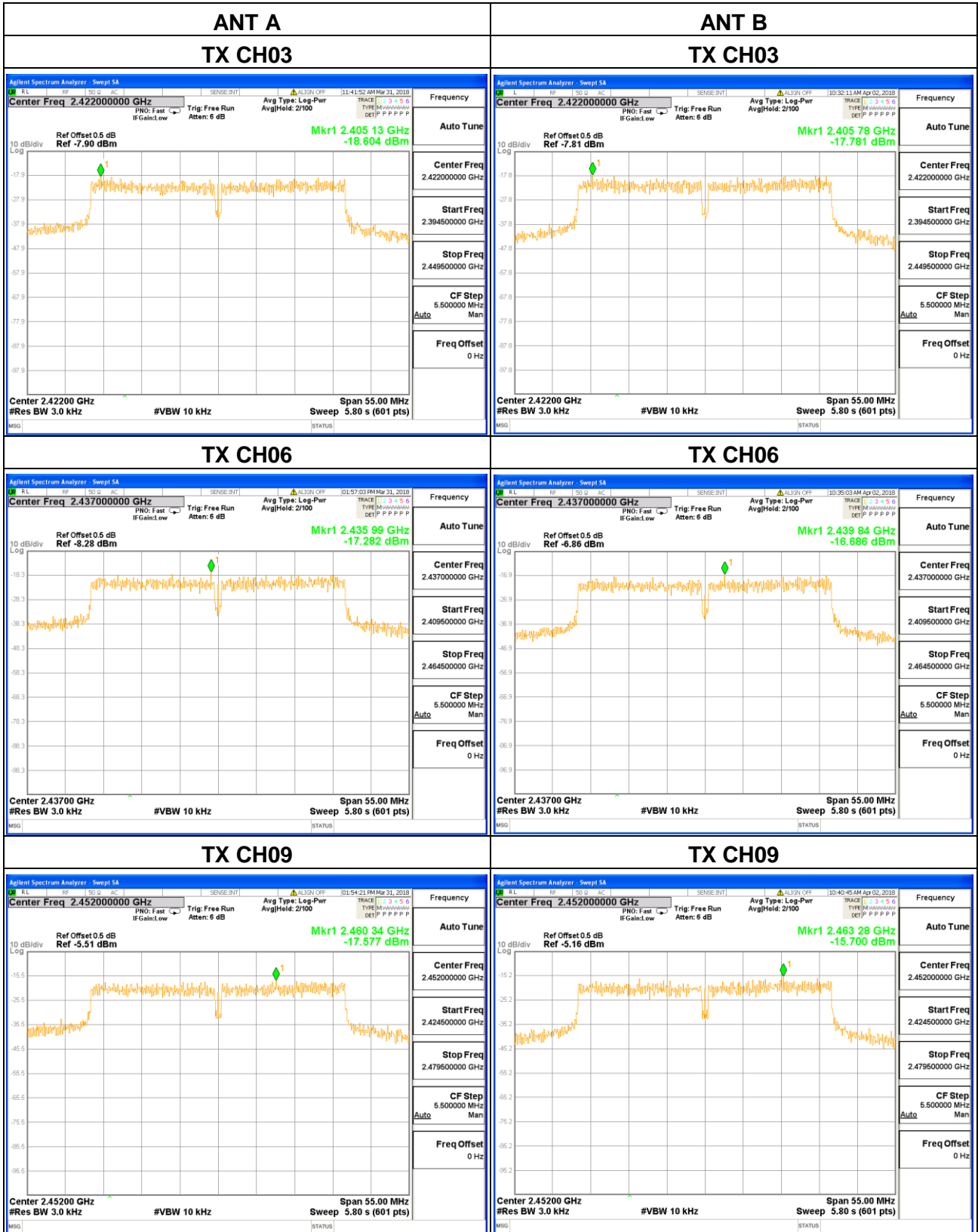

This test report is valid for the tested samples only. It cannot be reproduced except in full without prior written consent of Shenzhen Microtest Co., Ltd.

5.4 Conducted emission

5.4.1 Limits

FREQUENCY (MHz)	Class B (dBuV)	
	Quasi-peak	Average
0.15 -0.5	66 - 56 *	56 - 46 *
0.50 -5.0	56.00	46.00
5.0 -30.0	60.00	50.00

Note

- (1)The tighter limit applies at the band edges.
- (2)The limit of " * " marked band means the limitation decreases linearly with the logarithm of the frequency in the range.

5.4.2 Test setup

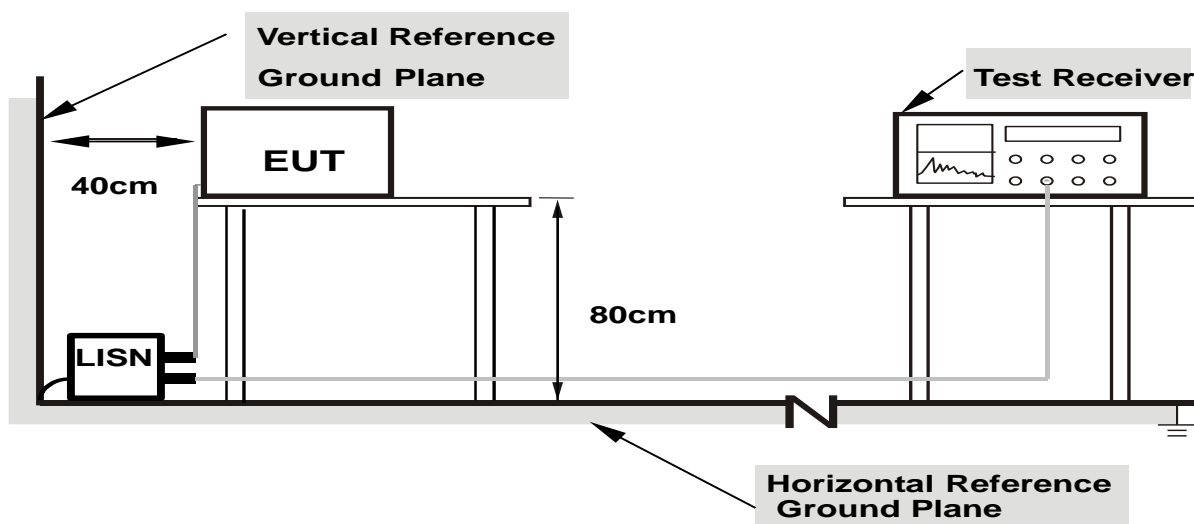

- Note: 1.Support units were connected to second LISN.**
2.Both of LISNs (AMN) are 80 cm from EUT and at least 80 from other units and other metal planes

This test report is valid for the tested samples only. It cannot be reproduced except in full without prior written consent of Shenzhen Microtest Co., Ltd.

5.4.3 Test procedure

a. EUT Operating Conditions

The EUT was configured for testing in a typical fashion (as a customer would normally use it). The EUT has been programmed to continuously transmit during test. This operating condition was tested and used to collect the included data.

b. The following table is the setting of the receiver

Receiver Parameters	Setting
Attenuation	10 dB
Start Frequency	0.15 MHz
Stop Frequency	30 MHz
IF Bandwidth	9 kHz

- c. The EUT was placed 0.8 meters from the horizontal ground plane with EUT being connected to the power mains through a line impedance stabilization network (LISN). All other support equipments powered from additional LISN(s). The LISN provide 50 Ohm/ 50uH of coupling impedance for the measuring instrument.
- d. Interconnecting cables that hang closer than 40 cm to the ground plane shall be folded back and forth in the center forming a bundle 30 to 40 cm long.
- e. I/O cables that are not connected to a peripheral shall be bundled in the center. The end of the cable may be terminated, if required, using the correct terminating impedance. The overall length shall not exceed 1 m.
- f. LISN at least 80 cm from nearest part of EUT chassis.

For the actual test configuration, please refer to the related Item –EUT Test Photos.

5.4.4 Test results

EUT :	Circle	Model Name. :	Circle2
Temperature :	26 °C	Relative Humidity :	54%
Pressure :	1010hPa	Phase :	L
Test Voltage :	DC 5V from adapter AC 120V/60Hz	Test Mode :	TX Mode

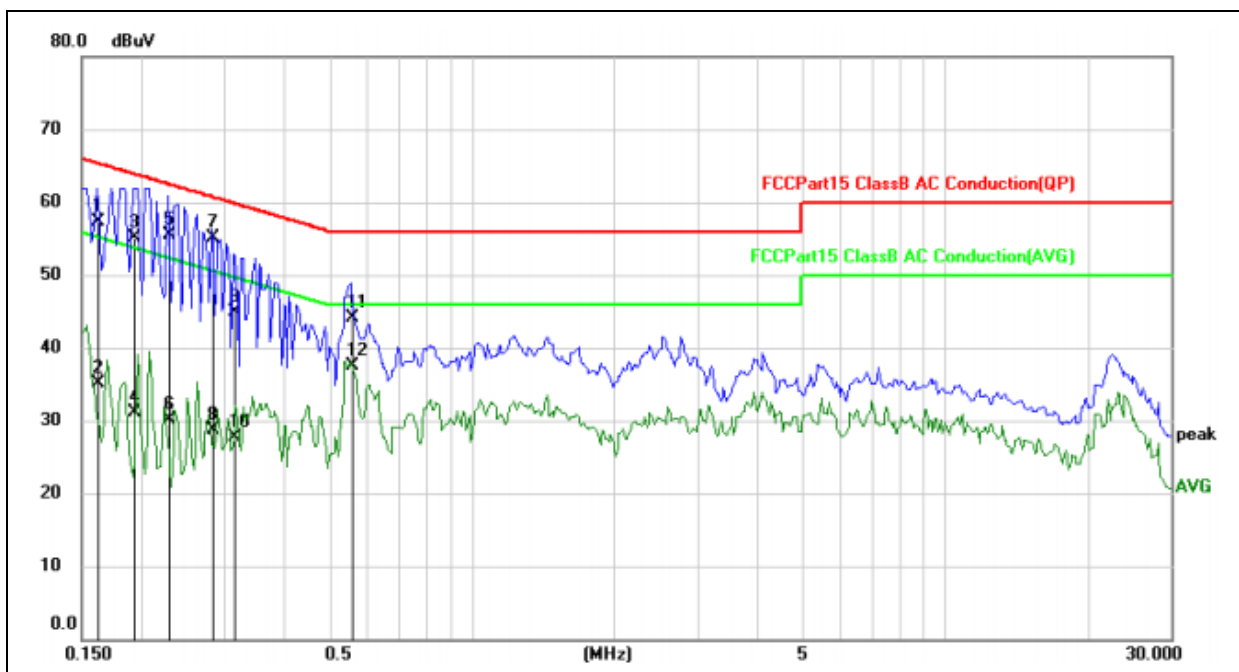

No.	Mk.	Freq. MHz	Reading Level dBuV	Correct Factor dB	Measure- ment dBuV	Limit dBuV	Over dB	Detector	Comment
1		0.1617	57.17	0.04	57.21	65.38	-8.17	QP	
2		0.1617	34.97	0.04	35.01	55.38	-20.37	AVG	
3		0.1930	55.10	0.04	55.14	63.91	-8.77	QP	
4		0.1930	31.01	0.04	31.05	53.91	-22.86	AVG	
5		0.2281	55.41	0.04	55.45	62.52	-7.07	QP	
6		0.2281	30.11	0.04	30.15	52.52	-22.37	AVG	
7	*	0.2828	55.12	0.04	55.16	60.73	-5.57	QP	
8		0.2828	28.63	0.04	28.67	50.73	-22.06	AVG	
9		0.3141	44.85	0.04	44.89	59.86	-14.97	QP	
10		0.3141	27.61	0.04	27.65	49.86	-22.21	AVG	
11		0.5563	44.02	0.04	44.06	56.00	-11.94	QP	
12		0.5563	37.53	0.04	37.57	46.00	-8.43	AVG	

This test report is valid for the tested samples only. It cannot be reproduced except in full without prior written consent of Shenzhen Microtest Co., Ltd.

EUT :	Circle	Model Name. :	Circle2
Temperature :	26 °C	Relative Humidity :	54%
Pressure :	1010hPa	Phase :	N
Test Voltage :	DC 5V from adapter AC 120V/60Hz	Test Mode :	TX Mode

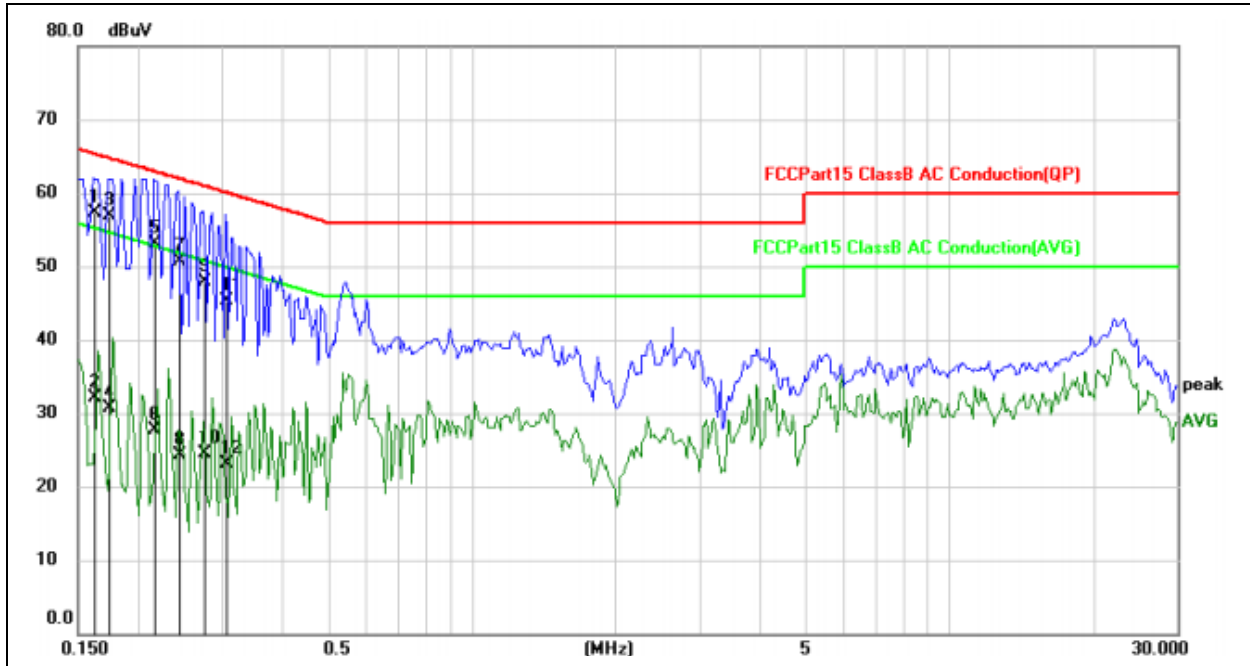

No.	Mk.	Freq. MHz	Reading Level dBuV	Correct Factor dB	Measure- ment dBuV	Limit dBuV	Over dB	Detector	Comment
1		0.1617	57.25	0.04	57.29	65.38	-8.09	QP	
2		0.1617	32.12	0.04	32.16	55.38	-23.22	AVG	
3	*	0.1734	56.79	0.04	56.83	64.80	-7.97	QP	
4		0.1734	30.76	0.04	30.80	54.80	-24.00	AVG	
5		0.2164	52.99	0.04	53.03	62.96	-9.93	QP	
6		0.2164	27.58	0.04	27.62	52.96	-25.34	AVG	
7		0.2437	50.64	0.04	50.68	61.97	-11.29	QP	
8		0.2437	24.26	0.04	24.30	51.97	-27.67	AVG	
9		0.2750	47.93	0.04	47.97	60.97	-13.00	QP	
10		0.2750	24.52	0.04	24.56	50.97	-26.41	AVG	
11		0.3063	45.33	0.04	45.37	60.07	-14.70	QP	
12		0.3063	22.98	0.04	23.02	50.07	-27.05	AVG	

This test report is valid for the tested samples only. It cannot be reproduced except in full without prior written consent of Shenzhen Microtest Co., Ltd.

5.5 Radiated spurious

5.5.1 Limits

20dBc in any 100 kHz bandwidth outside the operating frequency band. In case the emission fall within the restricted band specified on 15.205(a), then the 15.209(a) limit in the table below has to be followed.

Frequency (MHz)	Field Strength (micovolts/meter)	Measurement Distance (meters)
0.009~0.490	2400/F(KHz)	300
0.490~1.705	24000/F(KHz)	30
1.705~30.0	30	30
30~88	100	3
88~216	150	3
216~960	200	3
Above 960	500	3

Spectrum Parameter	Setting
Attenuation	Auto
Start Frequency	1000 MHz
Stop Frequency	10th carrier harmonic
RB / VB (emission in restricted band)	1 MHz / 1 MHz for Peak, 1 MHz / 10Hz for Average

Receiver Parameter	Setting
Attenuation	Auto
Start ~ Stop Frequency	9kHz~150kHz / RB 200Hz for QP
Start ~ Stop Frequency	150kHz~30MHz / RB 9kHz for QP
Start ~ Stop Frequency	30MHz~1000MHz / RB 120kHz for QP

This test report is valid for the tested samples only. It cannot be reproduced except in full without prior written consent of Shenzhen Microtest Co., Ltd.

5.5.2 Test setup

Radiated emission test-up frequency below 30MHz

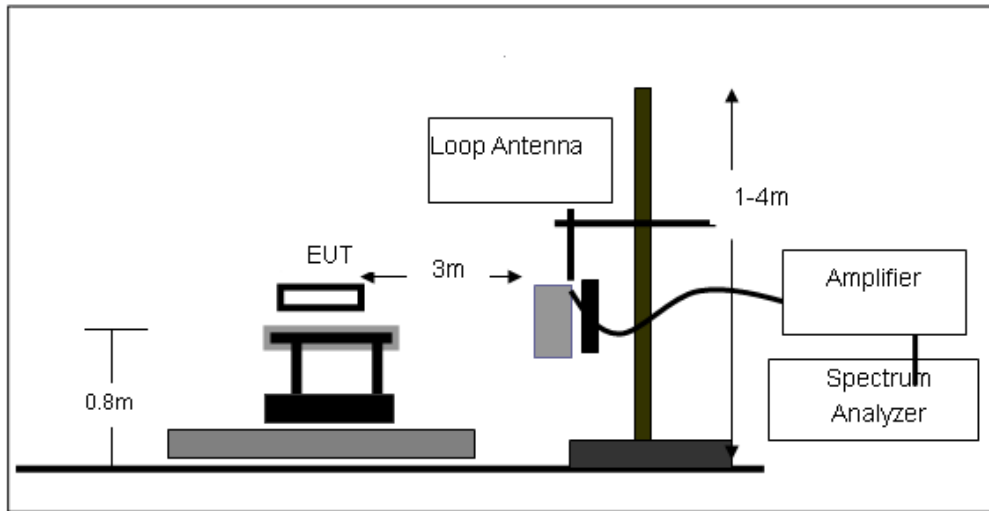

Radiated emission test-up frequency 30MHz~1GHz

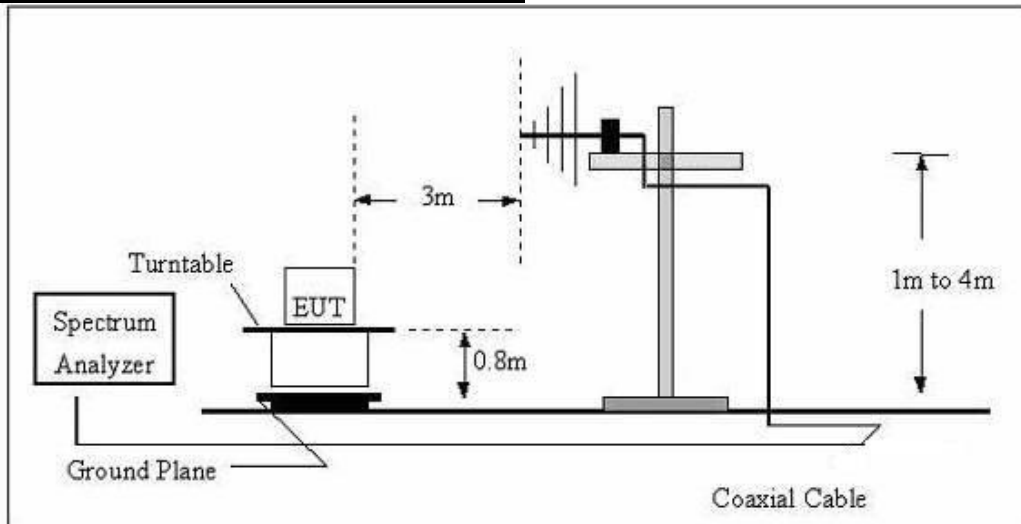

Radiated emission test-up frequency above 1GHz

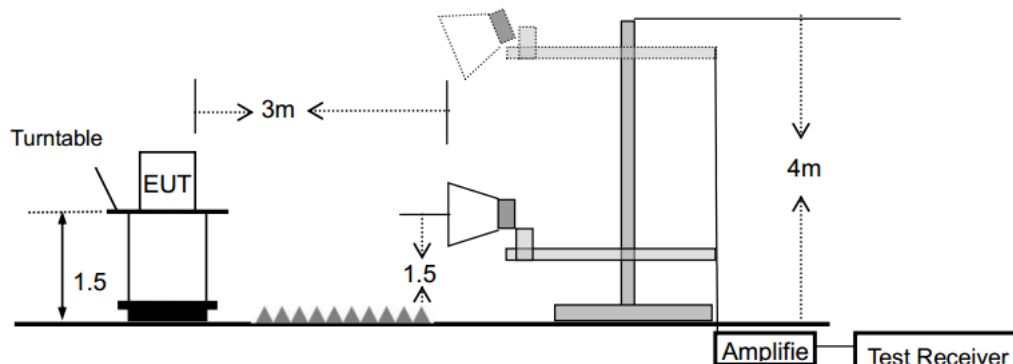

This test report is valid for the tested samples only. It cannot be reproduced except in full without prior written consent of Shenzhen Microtest Co., Ltd.

5.5.3 Test procedure

- a. The EUT is placed on a turntable, which is 0.8m above ground plane for test frequency range below 1GHz, and 1.5m above ground plane for test frequency range above 1GHz.
- b. EUT is set 3m away from the receiving antenna, which is varied from 1m to 4m to find out the highest emissions.
- c. Use the following spectrum analyzer settings:
Span = wide enough to fully capture the emission being measured, RBW = 1 MHz for $f \geq 1\text{GHz}$, 100 kHz for $f < 1\text{GHz}$, VBW \geq RBW, Sweep = auto, Detector function = peak, Trace = max hold.
- d. Follow the guidelines in ANSI C63.4-2014 with respect to maximizing the emission by rotating the EUT, adjusting the measurement antenna height and polarization, etc. The peak reading of the emission, after being corrected by the antenna factor, cable loss, pre-amp gain, etc., is the peak field strength, submit this data. Each emission was to be maximized by changing the polarization of receiving antenna both horizontal and vertical.
- e. The peak level, once corrected, must comply with the limit specified in Section 15.209. Set the RBW = 1MHz, VBW = 10Hz, Detector = RMS for AV value, while maintaining all of the other instrument settings.
- f. If the Peak Mode measured value compliance with and lower than Quasi Peak Mode Limit, the EUT shall be deemed to meet QP Limits and then no additional QP Mode measurement performed.
- g. For the actual test configuration, please refer to the related Item –EUT Test photos.

Note: Both horizontal and vertical antenna polarities were tested and performed pretest to three orthogonal axis. The worst case emissions were reported

5.5.4 Test results

5.5.4.1 Radiation emission

Below 30MHz

EUT:	Circle	Model Name:	Circle2
Temperature:	20 °C	Relative Humidity:	48%
Pressure:	1010 hPa	Test Voltage:	DC 5Vfrom adapter AC 120V/60Hz
Test Mode:	TX	Polarization :	--

Freq.	Reading	Limit	Margin	State
(MHz)	(dBuV/m)	(dBuV/m)	(dB)	P/F
--	--	--	--	Pass
--	--	--	--	Pass

Note:

The amplitude of spurious emissions which are attenuated by more than 20dB below the permissible value has no need to be reported.

Distance extrapolation factor = $40 \log (\text{specific distance}/\text{test distance})$ (dB);

Limit line = specific limits(dBuV) + distance extrapolation factor.

Between 30MHz – 1GHz

Note1 : Emission Level = Meter Reading + Factor, Margin= Emission Level- Limit, Factor = Antenna Factor + Cable Loss – Pre-amplifier.

Note2 : The peak value is less than the AV value, AV value is not required Factor added by measurement software automatically.

Note3: The following data is the worst mode. The worst data is antenna A 802.11 b

EUT :	Circle	Model Name. :	Circle2
Temperature :	26 °C	Relative Humidity :	54%
Pressure :	1010hPa	Phase :	H
Test Voltage :	DC 5V from adapter AC 120V/60Hz	Test Mode :	TX Mode

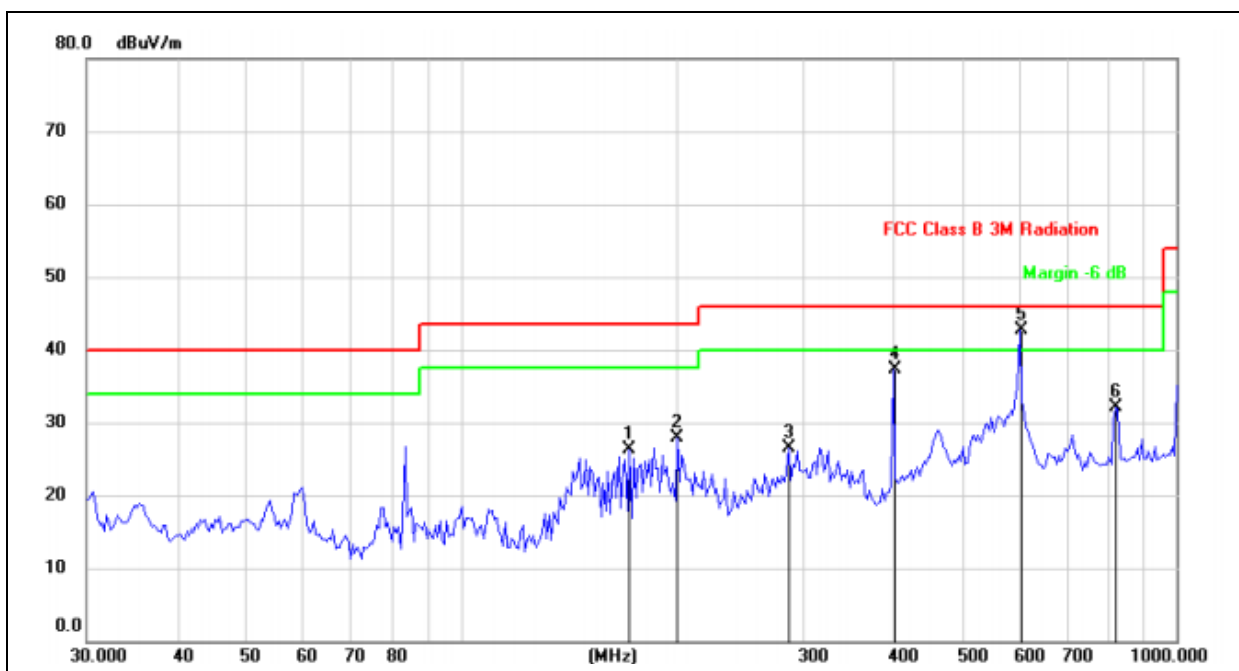

No. Mk.	Freq. MHz	Reading Level dBuV	Correct Factor dBuV/m	Measurement dBuV/m	Limit dBuV/m	Over dB	Detector	Antenna Height cm	Table Degree degree	Comment
1	171.9945	40.79	-14.49	26.30	43.50	-17.20	peak			
2	200.6880	39.64	-11.70	27.94	43.50	-15.56	peak			
3	286.9823	35.51	-8.98	26.53	46.00	-19.47	peak			
4	401.8385	43.79	-6.52	37.27	46.00	-8.73	peak			
5	* 603.5392	48.01	-5.30	42.71	46.00	-3.29	peak			
6	821.7103	34.66	-2.47	32.19	46.00	-13.81	peak			

This test report is valid for the tested samples only. It cannot be reproduced except in full without prior written consent of Shenzhen Microtest Co., Ltd.

EUT :	Circle	Model Name. :	Circle2
Temperature :	26 °C	Relative Humidity :	54%
Pressure :	1010hPa	Phase :	V
Test Voltage :	DC 5V from adapter AC 120V/60Hz	Test Mode :	TX Mode

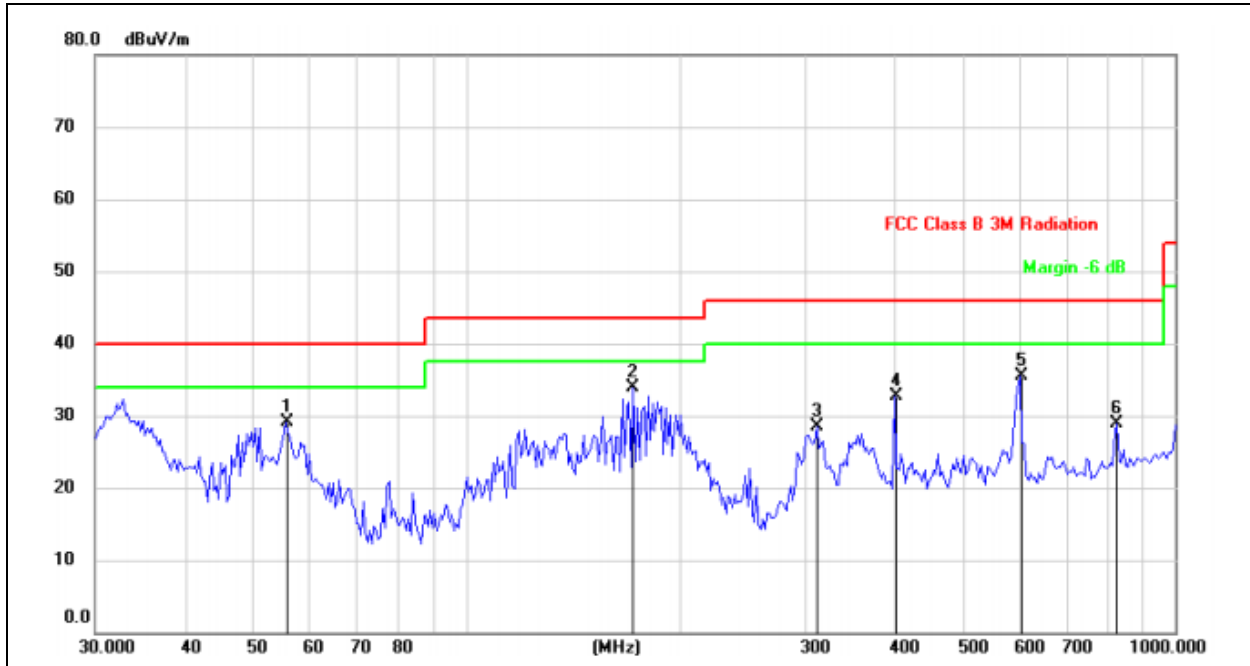

No.	Mk.	Freq.	Reading Level	Correct Factor	Measurement	Limit	Over	Antenna Height	Table Degree	
		MHz	dBuV	dBuV/m	dBuV/m	dBuV/m	dB	cm	degree	Comment
1		55.6094	39.63	-10.51	29.12	40.00	-10.88	peak		
2	*	171.9945	46.23	-12.29	33.94	43.50	-9.56	peak		
3		312.1792	36.77	-8.36	28.41	46.00	-17.59	peak		
4		401.8385	39.15	-6.52	32.63	46.00	-13.37	peak		
5		603.5392	40.18	-4.66	35.52	46.00	-10.48	peak		
6		827.4933	31.38	-2.39	28.99	46.00	-17.01	peak		

This test report is valid for the tested samples only. It cannot be reproduced except in full without prior written consent of Shenzhen Microtest Co., Ltd.

1G-25GHz

Note1 : Emission Level = Meter Reading + Factor, Margin= Emission Level- Limit, Factor = Antenna Factor + Cable Loss – Pre-amplifier.

Note2 : The peak value is less than the AV value, AV value is not required Factor added by measurement software automatically.

Note3: The following data is the worst mode. The worst data is antenna A

For 802.11b

Low Channel

No.	Frequency (MHz)	Meter Reading (dBuV)	Factor dB)	Emission Level (dBuV/m)	Limits (dBuV/m)	Margin (dB)	Polar (H/V)
1	3647.833	46.36	-4.02	42.34	74.00	-31.66	Horizontal
2	4843.847	49.79	-7.39	42.40	74.00	-31.60	Horizontal
3	6870.426	41.10	-3.29	37.81	74.00	-36.19	Horizontal
4	7235.875	44.61	-2.81	41.80	74.00	-32.20	Horizontal
5	8298.998	41.39	-1.93	39.46	74.00	-34.54	Horizontal
6	10491.690	39.88	2.25	42.13	74.00	-31.87	Horizontal

No.	Frequency (MHz)	Meter Reading (dBuV)	Factor dB)	Emission Level (dBuV/m)	Limits (dBuV/m)	Margin (dB)	Polar (H/V)
1	3415.275	47.92	-6.12	41.80	74.00	-32.20	Vertical
2	5242.518	45.13	-9.55	35.58	74.00	-38.42	Vertical
3	9063.118	42.61	-1.98	40.63	74.00	-33.37	Vertical
4	10823.916	43.30	0.28	43.58	74.00	-30.42	Vertical
5	13514.948	41.91	3.56	45.47	74.00	-28.53	Vertical
6	14611.294	38.25	5.00	43.25	74.00	-30.75	Vertical

Middle channel

No.	Frequency (MHz)	Meter Reading (dBuV)	Factor dB)	Emission Level (dBuV/m)	Limits (dBuV/m)	Margin (dB)	Polar (H/V)
1	4100.200	45.03	-3.18	41.85	74.00	-32.15	Horizontal
2	5803.607	43.62	-6.43	37.19	74.00	-36.81	Horizontal
3	8052.104	41.74	-1.87	39.87	74.00	-34.13	Horizontal
4	10232.465	35.22	2.06	37.28	74.00	-36.72	Horizontal
5	13571.142	35.07	4.79	39.86	74.00	-34.14	Horizontal
6	16977.956	35.46	9.15	44.61	74.00	-29.39	Horizontal

No.	Frequency (MHz)	Meter Reading (dBuV)	Factor dB)	Emission Level (dBuV/m)	Limits (dBuV/m)	Margin (dB)	Polar (H/V)
1	11799.599	47.30	0.31	47.61	74.00	-26.39	Vertical

This test report is valid for the tested samples only. It cannot be reproduced except in full without prior written consent of Shenzhen Microtest Co., Ltd.

2	12991.984	45.14	1.38	46.52	74.00	-27.48	Vertical
3	13775.551	43.50	4.80	48.30	74.00	-25.70	Vertical
4	15206.413	43.18	4.19	47.37	74.00	-26.63	Vertical
5	16909.820	40.60	7.23	47.83	74.00	-26.17	Vertical
6	17897.796	33.67	14.74	48.41	74.00	-25.59	Vertical

High channel

No.	Frequency (MHz)	Meter Reading (dBUV)	Factor dB	Emission Level (dBUV/m)	Limits (dBUV/m)	Margin (dB)	Polar (H/V)
1	3448.497	46.82	-4.63	42.19	74.00	-31.81	Horizontal
2	6305.642	44.32	-4.93	39.39	74.00	-34.61	Horizontal
3	8996.673	45.35	-0.87	44.48	74.00	-29.52	Horizontal
4	10691.026	44.16	2.29	46.45	74.00	-27.55	Horizontal
5	12518.270	43.44	2.97	46.41	74.00	-27.59	Horizontal
6	14378.736	44.61	5.32	49.93	74.00	-24.07	Horizontal

No.	Frequency (MHz)	Meter Reading (dBUV)	Factor dB	Emission Level (dBUV/m)	Limits (dBUV/m)	Margin (dB)	Polar (H/V)
1	4046.504	46.76	-4.50	42.26	74.00	-31.74	Vertical
2	7235.875	46.91	-4.55	42.36	74.00	-31.64	Vertical
3	8930.228	46.46	-2.20	44.26	74.00	-29.74	Vertical
4	10624.581	47.22	0.24	47.46	74.00	-26.54	Vertical
5	10624.581	47.22	0.24	47.46	74.00	-26.54	Vertical
6	14212.623	42.07	5.52	47.59	74.00	-26.41	Vertical

This test report is valid for the tested samples only. It cannot be reproduced except in full without prior written consent of Shenzhen Microtest Co., Ltd.

For 802.11g

Low Channel

No.	Frequency (MHz)	Meter Reading (dBuV)	Factor dB	Emission Level (dBuV/m)	Limits (dBuV/m)	Margin (dB)	Polar (H/V)
1	3997.996	48.83	-2.63	46.20	74.00	-27.80	Horizontal
2	7404.810	47.63	-2.75	44.88	74.00	-29.12	Horizontal
3	8937.876	46.94	-1.00	45.94	74.00	-28.06	Horizontal
4	10675.351	45.37	2.28	47.65	74.00	-26.35	Horizontal
5	11424.850	44.52	2.46	46.98	74.00	-27.02	Horizontal
6	14865.731	42.73	4.44	47.17	74.00	-26.83	Horizontal

No.	Frequency (MHz)	Meter Reading (dBuV)	Factor dB	Emission Level (dBuV/m)	Limits (dBuV/m)	Margin (dB)	Polar (H/V)
1	4202.405	48.69	-5.45	43.24	74.00	-30.76	Vertical
2	6519.038	49.82	-5.86	43.96	74.00	-30.04	Vertical
3	9687.375	48.98	-0.88	48.10	74.00	-25.90	Vertical
4	11527.054	48.41	0.38	48.79	74.00	-25.21	Vertical
5	12753.507	48.27	1.21	49.48	74.00	-24.52	Vertical
6	14456.914	43.86	5.14	49.00	74.00	-25.00	Vertical

Middle channel

No.	Frequency (MHz)	Meter Reading (dBuV)	Factor dB	Emission Level (dBuV/m)	Limits (dBuV/m)	Margin (dB)	Polar (H/V)
1	4066.132	50.57	-2.99	47.58	74.00	-26.42	Horizontal
2	6655.310	47.91	-3.96	43.95	74.00	-30.05	Horizontal
3	8869.739	47.78	-1.15	46.63	74.00	-27.37	Horizontal
4	9959.920	46.10	1.77	47.87	74.00	-26.13	Horizontal
5	11935.872	47.43	2.45	49.88	74.00	-24.12	Horizontal
6	13945.892	43.74	6.08	49.82	74.00	-24.18	Horizontal

No.	Frequency (MHz)	Meter Reading (dBuV)	Factor dB	Emission Level (dBuV/m)	Limits (dBuV/m)	Margin (dB)	Polar (H/V)
1	3997.996	52.86	-4.23	48.63	74.00	-25.37	Vertical
2	6553.106	51.85	-5.79	46.06	74.00	-27.94	Vertical
3	8869.739	49.22	-2.30	46.92	74.00	-27.08	Vertical

This test report is valid for the tested samples only. It cannot be reproduced except in full without prior written consent of Shenzhen Microtest Co., Ltd.

4	11663.327	47.86	0.34	48.20	74.00	-25.80	Vertical
5	4661.323	44.83	4.96	49.79	74.00	-24.21	Vertical
6	16501.002	43.46	4.79	48.25	74.00	-25.75	Vertical

High channel

No.	Frequency (MHz)	Meter Reading (dBuV)	Factor dB	Emission Level (dBuV/m)	Limits (dBuV/m)	Margin (dB)	Polar (H/V)
1	2430.862	107.13	-9.15	97.98	74.00	23.98	Horizontal
2	3997.996	50.56	-2.63	47.93	74.00	-26.07	Horizontal
3	8120.240	49.13	-1.88	47.25	74.00	-26.75	Horizontal
4	10028.056	48.08	1.91	49.99	74.00	-24.01	Horizontal
5	12753.507	48.94	3.03	51.97	74.00	-22.03	Horizontal
6	14082.164	45.98	6.06	52.04	74.00	-21.96	Horizontal

No.	Frequency (MHz)	Meter Reading (dBuV)	Factor dB	Emission Level (dBuV/m)	Limits (dBuV/m)	Margin (dB)	Polar (H/V)
1	3997.996	50.37	-4.23	46.14	74.00	-27.86	Vertical
2	6519.038	52.61	-5.86	46.75	74.00	-27.25	Vertical
3	6655.310	51.97	-5.55	46.42	74.00	-27.58	Vertical
4	10402.806	49.92	0.13	50.05	74.00	-23.95	Vertical
5	11799.599	50.55	0.31	50.86	74.00	-23.14	Vertical
6	13945.892	44.59	5.61	50.20	74.00	-23.80	Vertical

This test report is valid for the tested samples only. It cannot be reproduced except in full without prior written consent of Shenzhen Microtest Co., Ltd.

For 802.11n20

Low Channel

No.	Frequency (MHz)	Meter Reading (dBuV)	Factor dB	Emission Level (dBuV/m)	Limits (dBuV/m)	Margin (dB)	Polar (H/V)
1	3963.928	50.31	-2.76	47.55	74.00	-26.45	Horizontal
2	6621.243	48.15	-4.07	44.08	74.00	-29.92	Horizontal
3	8869.739	47.62	-1.15	46.47	74.00	-27.53	Horizontal
4	10436.874	45.30	2.22	47.52	74.00	-26.48	Horizontal
5	11424.850	45.48	2.46	47.94	74.00	-26.06	Horizontal
6	12991.984	45.40	3.08	48.48	74.00	-25.52	Horizontal

No.	Frequency (MHz)	Meter Reading (dBuV)	Factor dB	Emission Level (dBuV/m)	Limits (dBuV/m)	Margin (dB)	Polar (H/V)
1	4304.609	53.83	-6.06	47.77	74.00	-26.23	Vertical
2	6893.788	50.70	-5.02	45.68	74.00	-28.32	Vertical
3	9959.920	46.41	-0.30	46.11	74.00	-27.89	Vertical
4	10368.737	47.21	0.10	47.31	74.00	-26.69	Vertical
5	13162.325	45.78	2.06	47.84	74.00	-26.16	Vertical
6	14286.573	42.86	5.41	48.27	74.00	-25.73	Vertical

Middle channel

No.	Frequency (MHz)	Meter Reading (dBuV)	Factor dB	Emission Level (dBuV/m)	Limits (dBuV/m)	Margin (dB)	Polar (H/V)
1	3997.996	51.18	-2.63	48.55	74.00	-25.45	Horizontal
2	6519.038	50.82	-4.39	46.43	74.00	-27.57	Horizontal
3	9755.511	48.07	1.14	49.21	74.00	-24.79	Horizontal
4	10505.010	47.98	2.27	50.25	74.00	-23.75	Horizontal
5	14763.527	44.52	4.60	49.12	74.00	-24.88	Horizontal
6	17182.365	40.38	10.08	50.46	74.00	-23.54	Horizontal

No.	Frequency (MHz)	Meter Reading (dBuV)	Factor dB	Emission Level (dBuV/m)	Limits (dBuV/m)	Margin (dB)	Polar (H/V)
1	3895.792	52.58	-4.59	47.99	74.00	-26.01	Vertical
2	6519.038	52.11	-5.86	46.25	74.00	-27.75	Vertical
3	7949.900	50.02	-3.72	46.30	74.00	-27.70	Vertical
4	8869.739	49.69	-2.30	47.39	74.00	-26.61	Vertical

This test report is valid for the tested samples only. It cannot be reproduced except in full without prior written consent of Shenzhen Microtest Co., Ltd.

5	10539.078	47.60	0.22	47.82	74.00	-26.18	Vertical
6	14320.641	43.66	5.35	49.01	74.00	-24.99	Vertical

High channel

No.	Frequency (MHz)	Meter Reading (dBuV)	Factor dB)	Emission Level (dBuV/m)	Limits (dBuV/m)	Margin (dB)	Polar (H/V)
1	3963.928	50.26	-2.76	47.50	74.00	-26.50	Horizontal
2	6621.243	50.47	-4.07	46.40	74.00	-27.60	Horizontal
3	7404.810	49.90	-2.75	47.15	74.00	-26.85	Horizontal
4	9653.307	48.15	0.83	48.98	74.00	-25.02	Horizontal
5	11595.190	48.22	2.48	50.70	74.00	-23.30	Horizontal
6	12787.575	48.20	3.03	51.23	74.00	-22.77	Horizontal

No.	Frequency (MHz)	Meter Reading (dBuV)	Factor dB)	Emission Level (dBuV/m)	Limits (dBuV/m)	Margin (dB)	Polar (H/V)
1	7609.218	50.68	-4.14	46.54	74.00	-27.46	Vertical
2	9653.307	48.63	-0.96	47.67	74.00	-26.33	Vertical
3	9653.307	48.63	-0.96	47.67	74.00	-26.33	Vertical
4	12889.780	48.78	1.30	50.08	74.00	-23.92	Vertical
5	14388.778	43.70	5.24	48.94	74.00	-25.06	Vertical
6	17727.455	35.01	13.36	48.37	74.00	-25.63	Vertical

This test report is valid for the tested samples only. It cannot be reproduced except in full without prior written consent of Shenzhen Microtest Co., Ltd.

For 802.11n40

Low Channel

No.	Frequency (MHz)	Meter Reading (dBUV)	Factor dB)	Emission Level (dBUV/m)	Limits (dBUV/m)	Margin (dB)	Polar (H/V)
1	3997.996	51.06	-2.63	48.43	74.00	-25.57	Horizontal
2	6587.174	50.86	-4.18	46.68	74.00	-27.32	Horizontal
3	9619.238	45.95	0.72	46.67	74.00	-27.33	Horizontal
4	10505.010	46.04	2.27	48.31	74.00	-25.69	Horizontal
5	12719.439	48.55	3.01	51.56	74.00	-22.44	Horizontal
6	14559.118	46.31	4.93	51.24	74.00	-22.76	Horizontal

No.	Frequency (MHz)	Meter Reading (dBUV)	Factor dB)	Emission Level (dBUV/m)	Limits (dBUV/m)	Margin (dB)	Polar (H/V)
1	3997.996	52.17	-4.23	47.94	74.00	-26.06	Vertical
2	6382.766	52.92	-6.29	46.63	74.00	-27.37	Vertical
3	6621.243	51.66	-5.63	46.03	74.00	-27.97	Vertical
4	8188.377	49.16	-3.39	45.77	74.00	-28.23	Vertical
5	10368.737	44.46	0.10	44.56	74.00	-29.44	Vertical
6	14422.846	40.53	5.19	45.72	74.00	-28.28	Vertical

Middle channel

No.	Frequency (MHz)	Meter Reading (dBUV)	Factor dB)	Emission Level (dBUV/m)	Limits (dBUV/m)	Margin (dB)	Polar (H/V)
1	7370.742	48.64	-2.76	45.88	74.00	-28.12	Horizontal
2	10164.329	45.03	2.01	47.04	74.00	-26.96	Horizontal
3	12685.371	44.86	3.00	47.86	74.00	-26.14	Horizontal
4	14116.233	41.94	5.97	47.91	74.00	-26.09	Horizontal
5	14865.731	44.11	4.44	48.55	74.00	-25.45	Horizontal
6	16875.751	40.52	8.57	49.09	74.00	-24.91	Horizontal

No.	Frequency (MHz)	Meter Reading (dBUV)	Factor dB)	Emission Level (dBUV/m)	Limits (dBUV/m)	Margin (dB)	Polar (H/V)
1	6621.243	52.10	-5.63	46.47	74.00	-27.53	Vertical
2	8869.739	49.73	-2.30	47.43	74.00	-26.57	Vertical

This test report is valid for the tested samples only. It cannot be reproduced except in full without prior written consent of Shenzhen Microtest Co., Ltd.

3	10096.192	49.48	-0.14	49.34	74.00	-24.66	Vertical
4	12106.212	49.98	0.41	50.39	74.00	-23.61	Vertical
5	13060.120	50.20	1.64	51.84	74.00	-22.16	Vertical
6	15172.345	46.10	4.28	50.38	74.00	-23.62	Vertical

High channel

No.	Frequency (MHz)	Meter Reading (dBuV)	Factor dB	Emission Level (dBuV/m)	Limits (dBuV/m)	Margin (dB)	Polar (H/V)
1	4134.269	51.66	-3.37	48.29	74.00	-25.71	Horizontal
2	6519.038	50.34	-4.39	45.95	74.00	-28.05	Horizontal
3	9721.443	45.81	1.03	46.84	74.00	-27.16	Horizontal
4	12617.235	45.94	2.99	48.93	74.00	-25.07	Horizontal
5	13094.188	45.20	3.35	48.55	74.00	-25.45	Horizontal
6	18000.000	37.25	13.96	51.21	74.00	-22.79	Horizontal

No.	Frequency (MHz)	Meter Reading (dBuV)	Factor dB	Emission Level (dBuV/m)	Limits (dBuV/m)	Margin (dB)	Polar (H/V)
1	4100.200	52.44	-4.82	47.62	74.00	-26.38	Vertical
2	6484.970	51.04	-5.95	45.09	74.00	-28.91	Vertical
3	8699.399	47.47	-2.61	44.86	74.00	-29.14	Vertical
4	10743.487	47.95	0.26	48.21	74.00	-25.79	Vertical
5	12719.439	47.82	1.17	48.99	74.00	-25.01	Vertical
6	16739.479	38.91	6.22	45.13	74.00	-28.87	Vertical

This test report is valid for the tested samples only. It cannot be reproduced except in full without prior written consent of Shenzhen Microtest Co., Ltd.

5.5.4.2 Band edge - radiated

Note1 : Emission Level = Meter Reading + Factor, Margin= Emission Level- Limit, Factor = Antenna Factor + Cable Loss – Pre-amplifier.

Note2 : The peak value is less than the AV value, AV value is not required Factor added by measurement software automatically.

Note3: The following data is the worst mode. The worst mode is antenna A

Frequency	Meter Reading	Factor	Emission Level	Limits	Margin	Detector Type	Polar (H/V)
(MHz)	(dBμV)	(dB)	(dBμV/m)	(dBμV/m)	(dB)		
802.11b -- 2412MHz							
2390	55.03	-10.38	44.65	74.00	-29.35	peak	Vertical
2390	55.15	-9.53	45.62	74.00	-28.38	peak	Horizontal
2400	52.82	-10.31	42.51	74.00	-31.49	peak	Vertical
2400	55.87	-9.43	46.44	74.00	-27.56	peak	Horizontal
2483.5	53.09	-9.73	43.36	74.00	-30.64	peak	Vertical
2483.5	55.09	-8.66	46.43	74.00	-27.57	peak	Horizontal
802.11g-- 2462MHz							
2390	61.77	-10.38	51.39	74.00	-22.61	peak	Vertical
2390	62.11	-9.53	52.58	74.00	-21.42	peak	Horizontal
2400	54.67	-10.31	44.36	74.00	-29.64	peak	Vertical
2400	55.03	-9.43	45.60	74.00	-28.40	peak	Horizontal
2483.5	49.95	-9.73	40.22	74.00	-33.78	peak	Vertical
2483.5	58.52	-8.66	49.86	74.00	-24.14	peak	Horizontal
802.11n20-- 2412MHz							
2390	54.22	-10.38	43.84	74.00	-30.16	peak	Vertical
2390	53.31	-9.53	43.78	74.00	-30.22	peak	Horizontal
2400	61.69	-10.31	51.38	74.00	-22.62	peak	Vertical
2400	61.27	-9.43	51.84	74.00	-22.16	peak	Horizontal
2483.5	54.26	-9.73	44.53	74.00	-29.47	peak	Vertical
2483.5	54.14	-8.66	45.48	74.00	-28.52	peak	Horizontal
802.11n40-- 2452MHz							
2390	55.98	-10.38	45.60	74.00	-28.40	55.98	Vertical
2390	54.88	-9.53	45.35	74.00	-28.65	peak	Horizontal
2400	62.58	-10.31	52.27	74.00	-21.73	peak	Vertical
2400	62.87	-9.43	53.44	74.00	-20.56	peak	Horizontal
2483.5	54.03	-9.73	44.30	74.00	-29.70	peak	Vertical
2483.5	53.89	-8.66	45.23	74.00	-28.77	peak	Horizontal

This test report is valid for the tested samples only. It cannot be reproduced except in full without prior written consent of Shenzhen Microtest Co., Ltd.

5.6 Conduction spurious emission

5.6.1 Limits

In any 100 kHz bandwidth outside the frequency band in which the spread spectrum or digitally modulated intentional radiator is operating, the radio frequency power that is produced by the intentional radiator shall be at least 20 dB below that in the 100 kHz bandwidth within the band that contains the highest level of the desired power, based on either an RF conducted or a radiated measurement, provided the transmitter demonstrates compliance with the peak conducted power limits. If the transmitter complies with the conducted power limits based on the use of RMS averaging over a time interval, as permitted under paragraph (b)(3) of this section, the attenuation required under this paragraph shall be 30 dB instead of 20 dB. Attenuation below the general limits specified in §15.209(a) is not required. In addition, radiated emissions which fall in the restricted bands, as defined in §15.205(a), must also comply with the radiated emission limits specified in §15.209(a) (see §15.205(c)).

5.6.2 Test setup

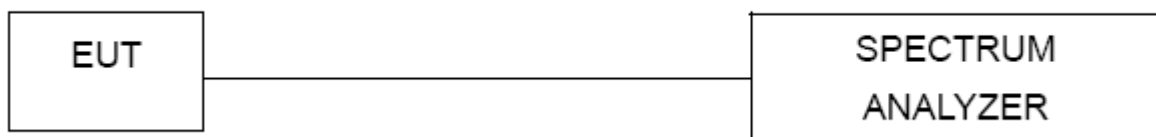

5.6.3 Test procedure

- a) Check the calibration of the measuring instrument using either an internal calibrator or a known signal from an external generator.
- b) Position the EUT without connection to measurement instrument. Turn on the EUT and connect its antenna terminal to measurement instrument via a low loss cable. Then set it to any one measured frequency within its operating range, and make sure the instrument is operated in its linear range.
- c) Set RBW to 100 kHz and VBW of spectrum analyzer to 300 kHz with a convenient frequency span including 100 kHz bandwidth from band edge.
- d) Measure the highest amplitude appearing on spectral display and set it as a reference level. Plot the graph with marking the highest point and edge frequency.
- e) Repeat above procedures until all measured frequencies were complete.

5.6.4 Test results

For ANT A

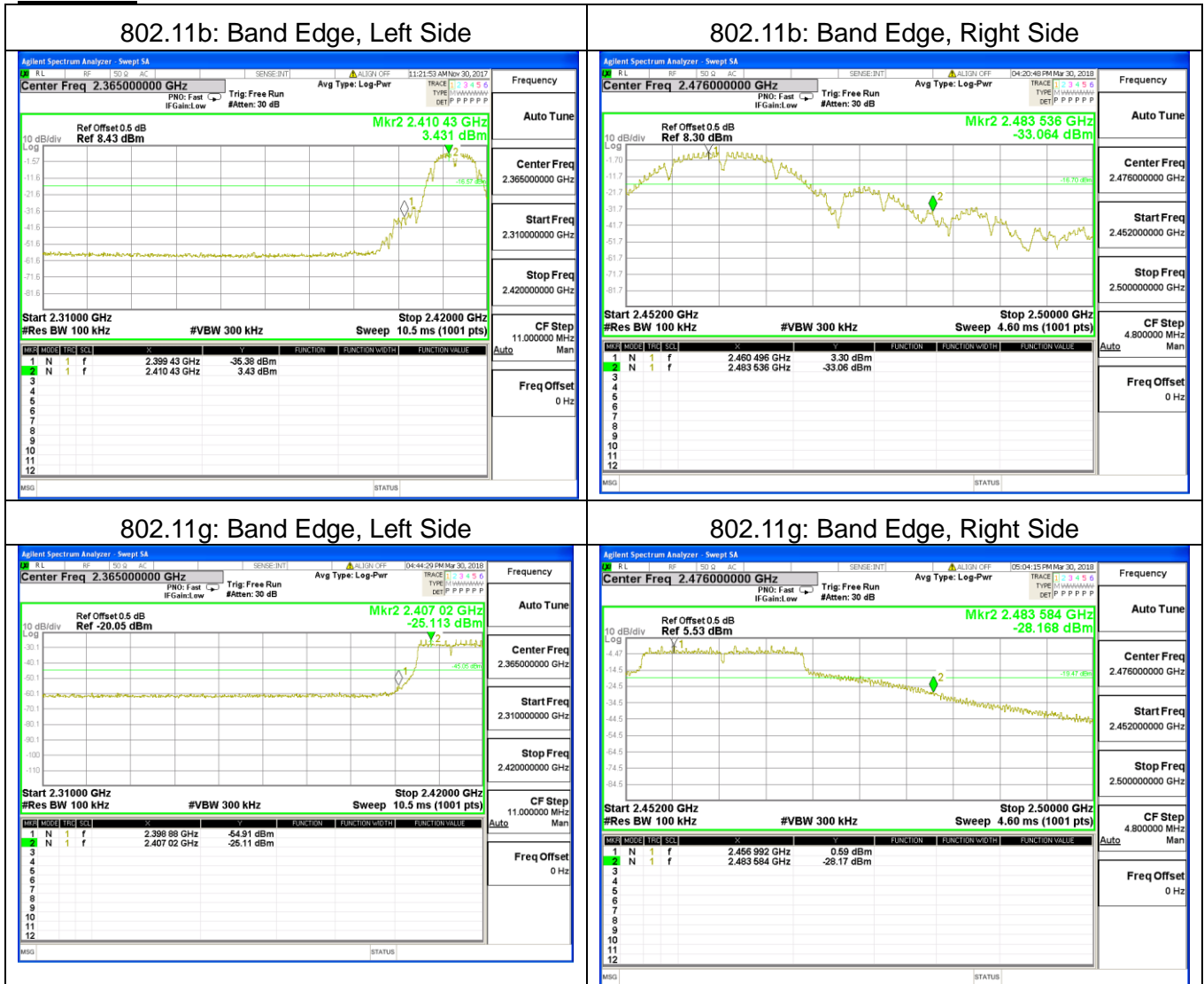

This test report is valid for the tested samples only. It cannot be reproduced except in full without prior written consent of Shenzhen Microtest Co., Ltd.

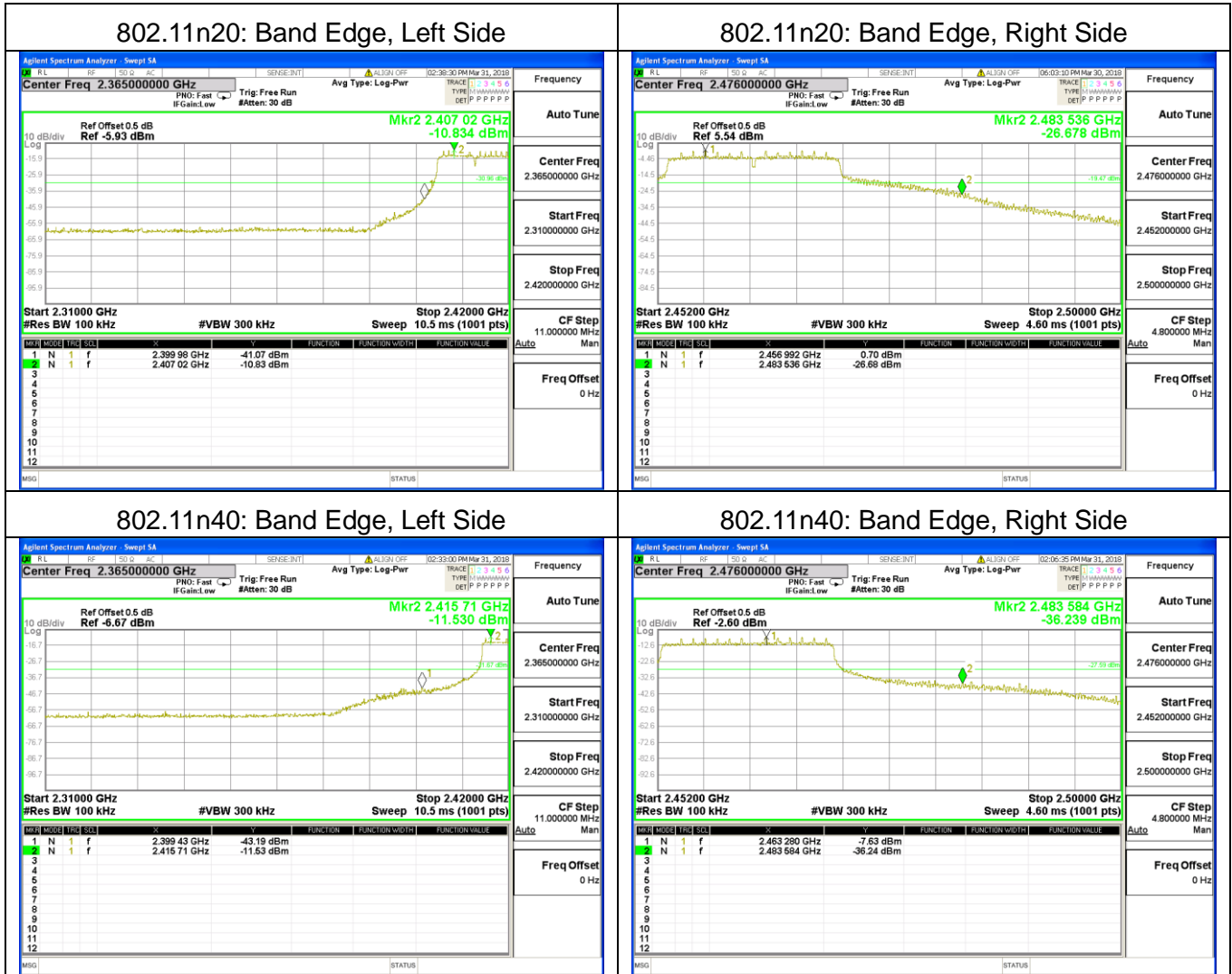

This test report is valid for the tested samples only. It cannot be reproduced except in full without prior written consent of Shenzhen Microtest Co., Ltd.

For ANT B

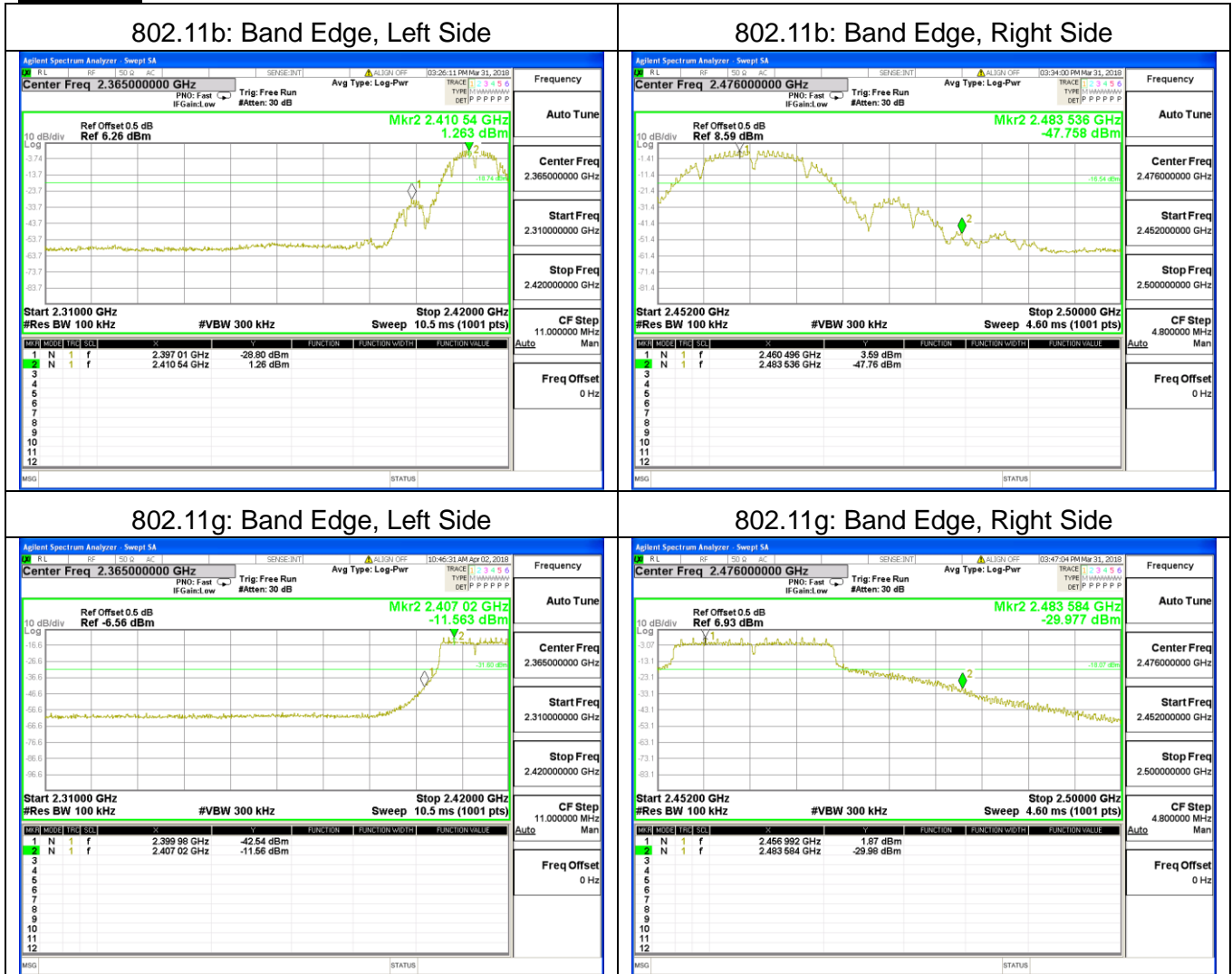

This test report is valid for the tested samples only. It cannot be reproduced except in full without prior written consent of Shenzhen Microtest Co., Ltd.

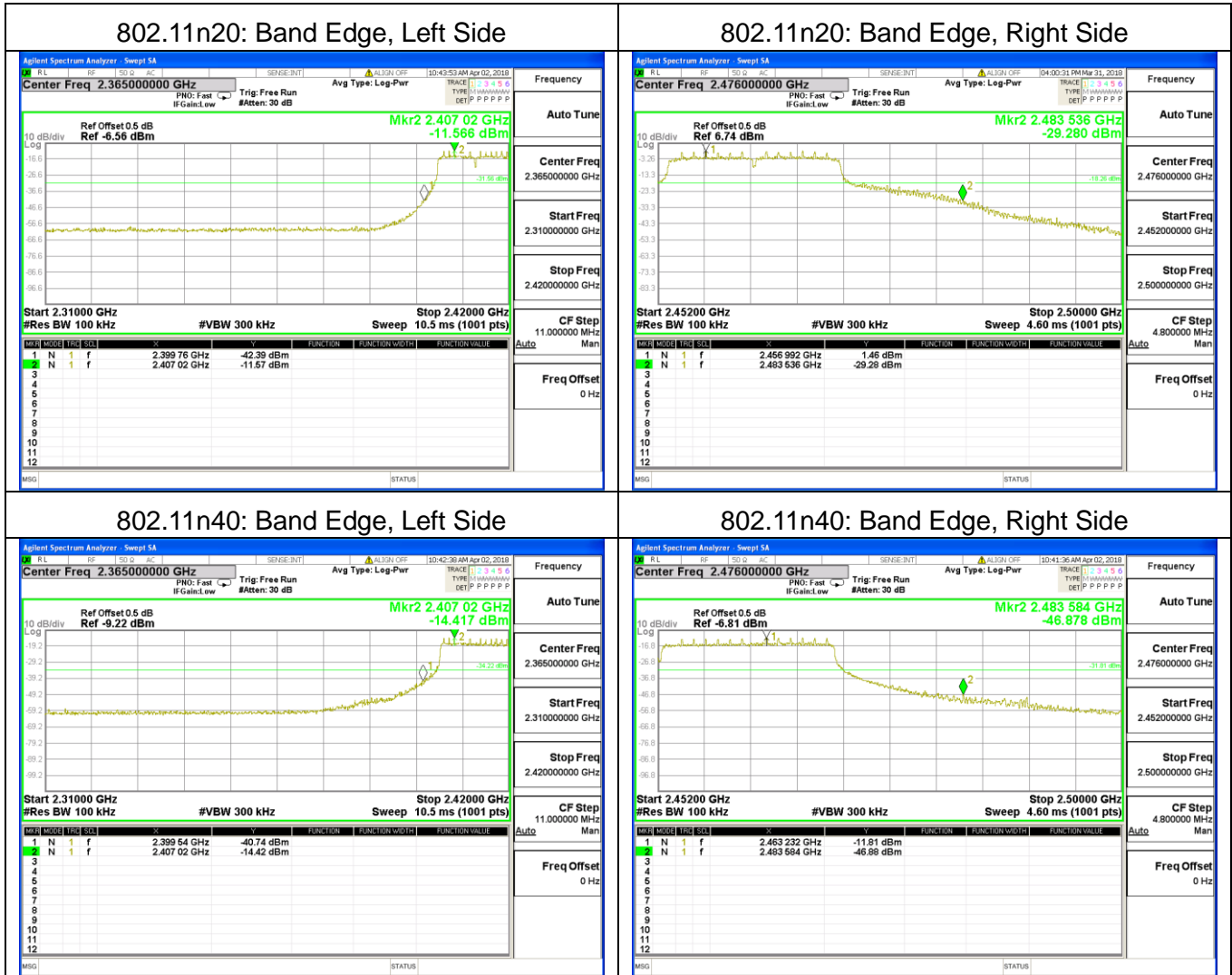

This test report is valid for the tested samples only. It cannot be reproduced except in full without prior written consent of Shenzhen Microtest Co., Ltd.

5.7 6dB bandwidth

5.7.1 Limit

FCC Part15 Subpart C				
Section	Test Item	Limit	Frequency Range (MHz)	Result
15.247(a)(2)	Bandwidth	$\geq 500\text{KHz}$ (6dB bandwidth)	2400-2483.5	Pass

5.7.2 Test setup



5.7.3 Test procedure

- a. Set RBW= 100 kHz.
- b. Set the video bandwidth (VBW) $\geq 3 \times$ RBW.
- c. Detector = Peak.
- d. Trace mode = max hold.
- e. Sweep = auto couple.
- f. Allow the trace to stabilize.
- g. Measure the maximum width of the emission that is constrained by the frequencies associated with the two outermost amplitude points (upper and lower) that are attenuated by 6 dB relative to the maximum level measured in the fundamental emission.

EUT Operation Conditions

The EUT tested system was configured as the statements of 2.4 Unless otherwise a special operating condition is specified in the follows during the testing.

5.7.4 Test results

802.11b

ANT A:

Test Channel	Frequency (MHz)	6dB bandwidth (MHz)	Limit (kHz)	Result
CH01	2412	10.10	500	Pass
CH06	2437	10.10	500	Pass
CH11	2462	11.06	500	Pass

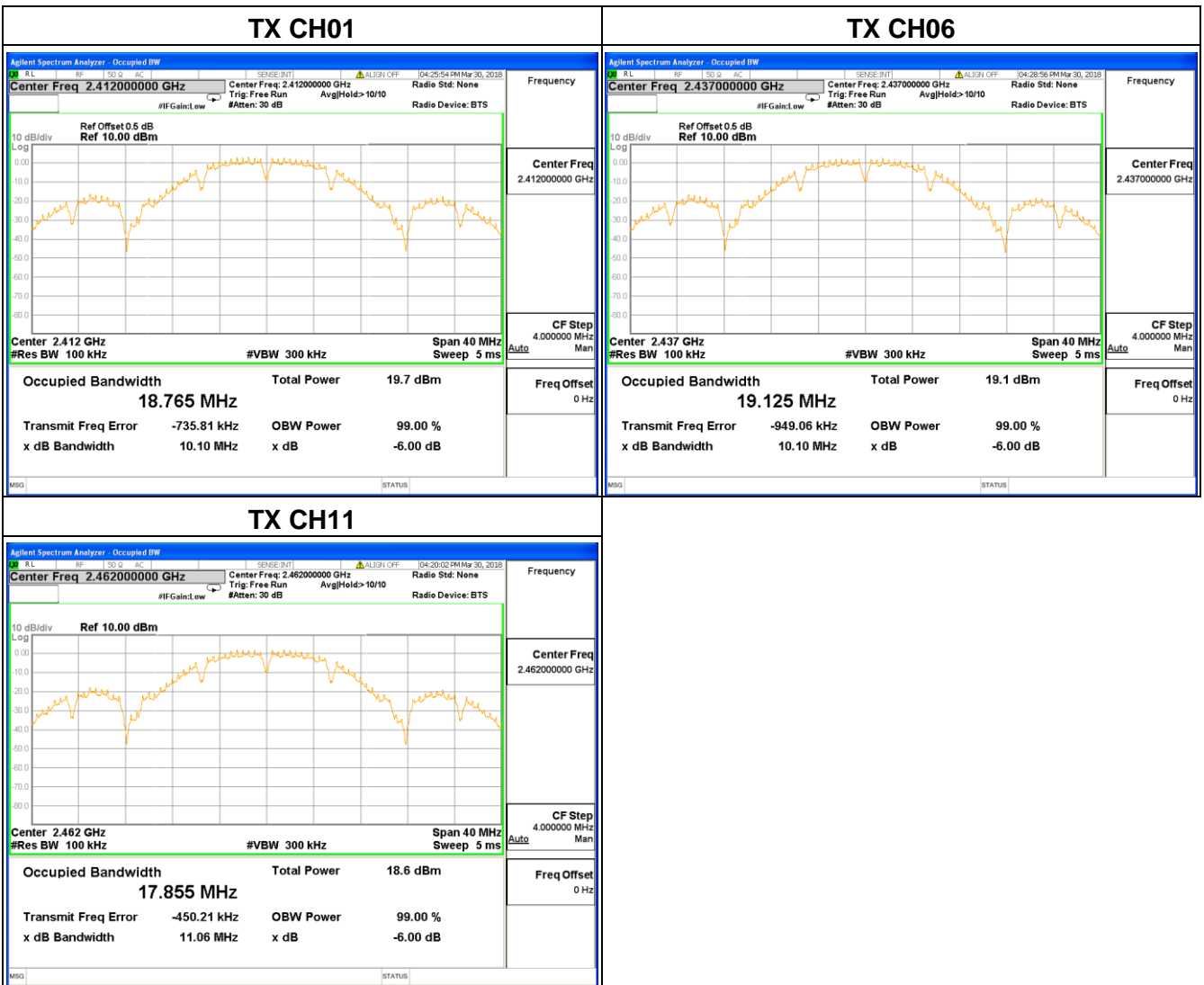

This test report is valid for the tested samples only. It cannot be reproduced except in full without prior written consent of Shenzhen Microtest Co., Ltd.

ANT B:

Test Channel	Frequency (MHz)	6dB bandwidth (MHz)	Limit (kHz)	Result
CH01	2412	10.09	500	Pass
CH06	2437	10.09	500	Pass
CH11	2462	10.09	500	Pass

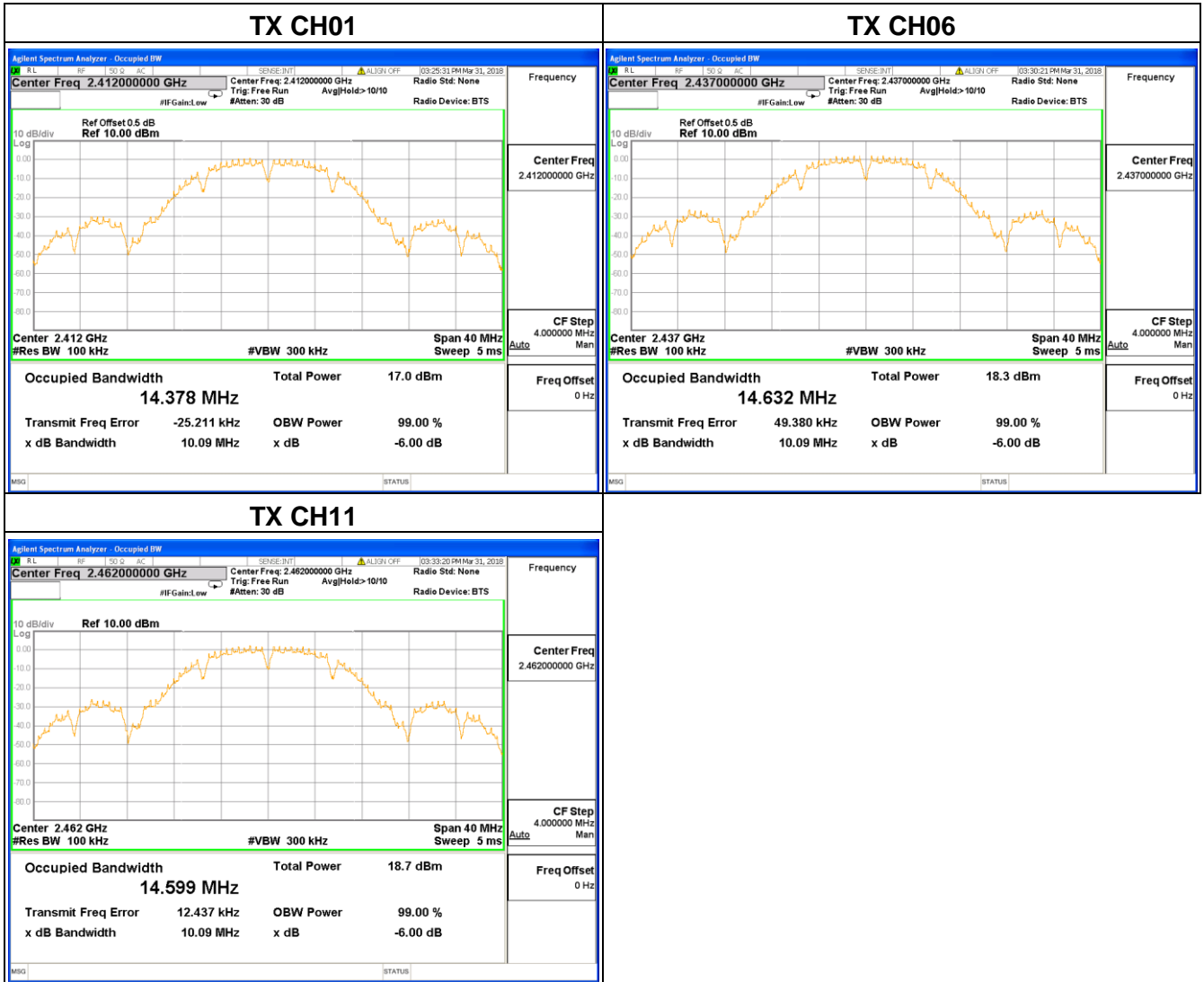

This test report is valid for the tested samples only. It cannot be reproduced except in full without prior written consent of Shenzhen Microtest Co., Ltd.

802.11g

ANT A:

Test Channel	Frequency (MHz)	6dB bandwidth (MHz)	Limit (kHz)	Result
CH01	2412	16.37	500	Pass
CH06	2437	16.36	500	Pass
CH11	2462	16.35	500	Pass

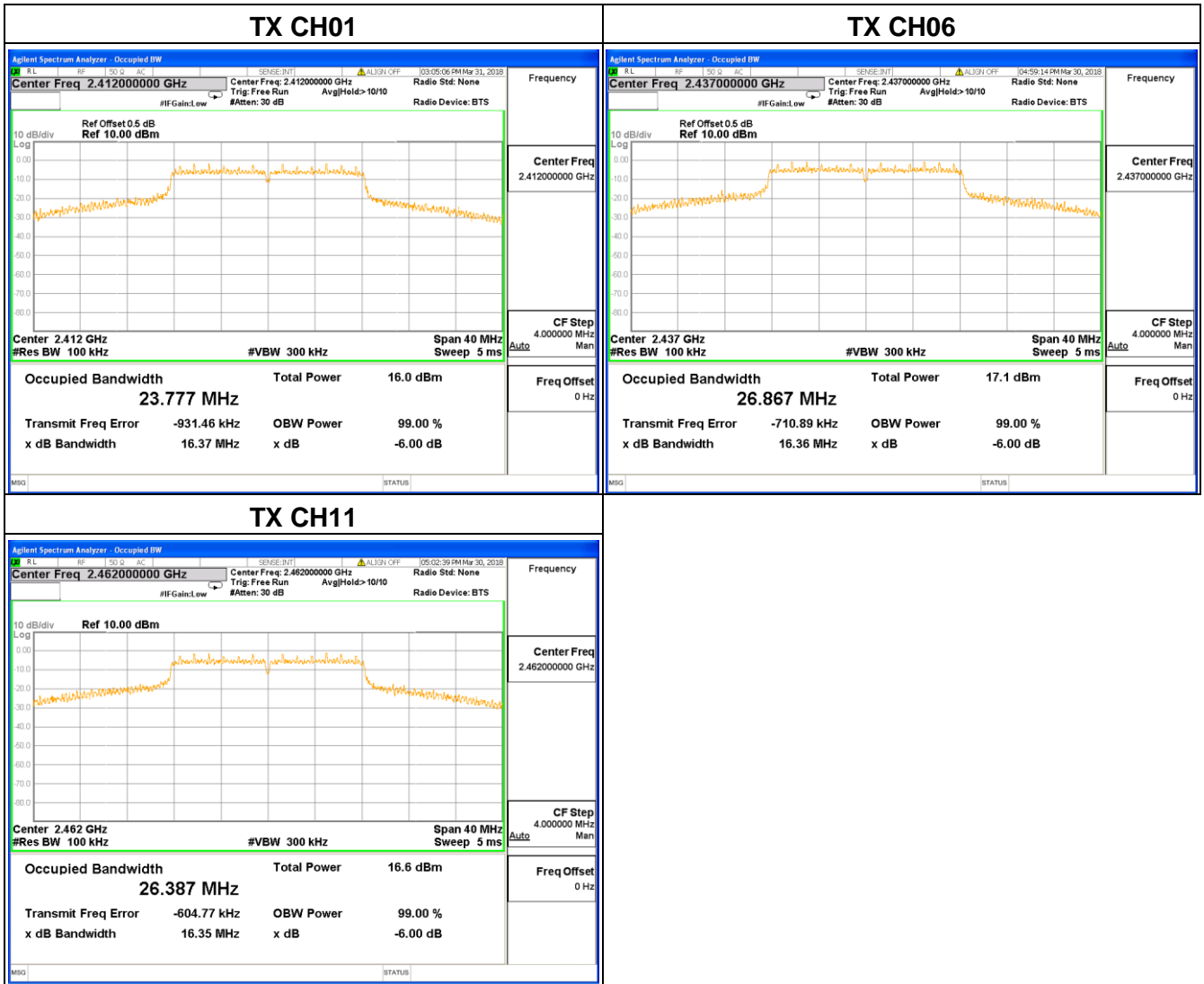

This test report is valid for the tested samples only. It cannot be reproduced except in full without prior written consent of Shenzhen Microtest Co., Ltd.

ANT B:

Test Channel	Frequency (MHz)	6dB bandwidth (MHz)	Limit (kHz)	Result
CH01	2412	16.35	500	Pass
CH06	2437	16.37	500	Pass
CH11	2462	16.37	500	Pass

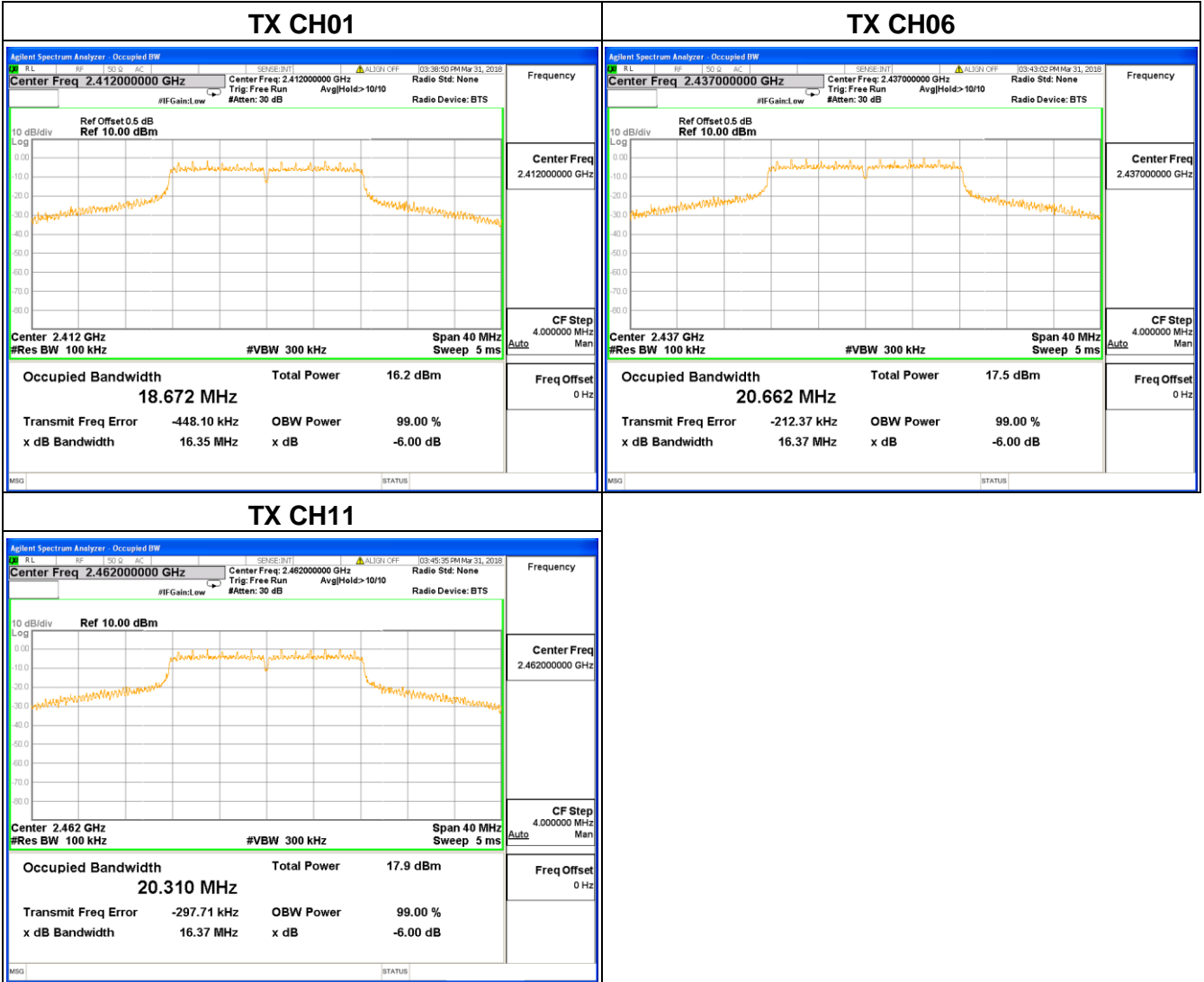

This test report is valid for the tested samples only. It cannot be reproduced except in full without prior written consent of Shenzhen Microtest Co., Ltd.

For 802.11n20

ANTA

Test Channel	Frequency (MHz)	6dB bandwidth (MHz)	Limit (kHz)	Result
CH01	2412	17.56	500	Pass
CH06	2437	17.59	500	Pass
CH11	2462	17.60	500	Pass

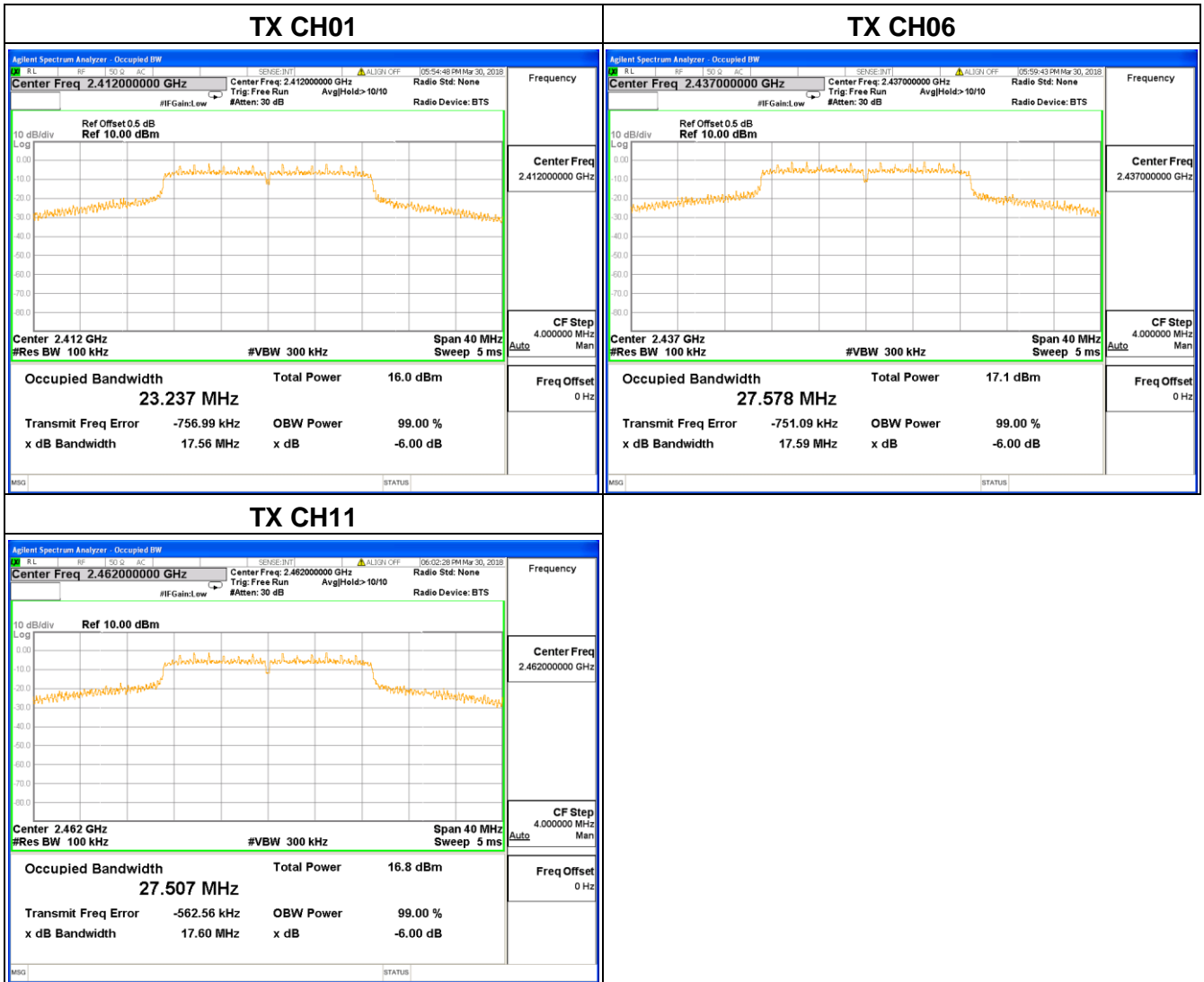

This test report is valid for the tested samples only. It cannot be reproduced except in full without prior written consent of Shenzhen Microtest Co., Ltd.

ANTB

Test Channel	Frequency (MHz)	6dB bandwidth (MHz)	Limit (kHz)	Result
CH01	2412	17.57	500	Pass
CH06	2437	17.59	500	Pass
CH11	2462	17.56	500	Pass

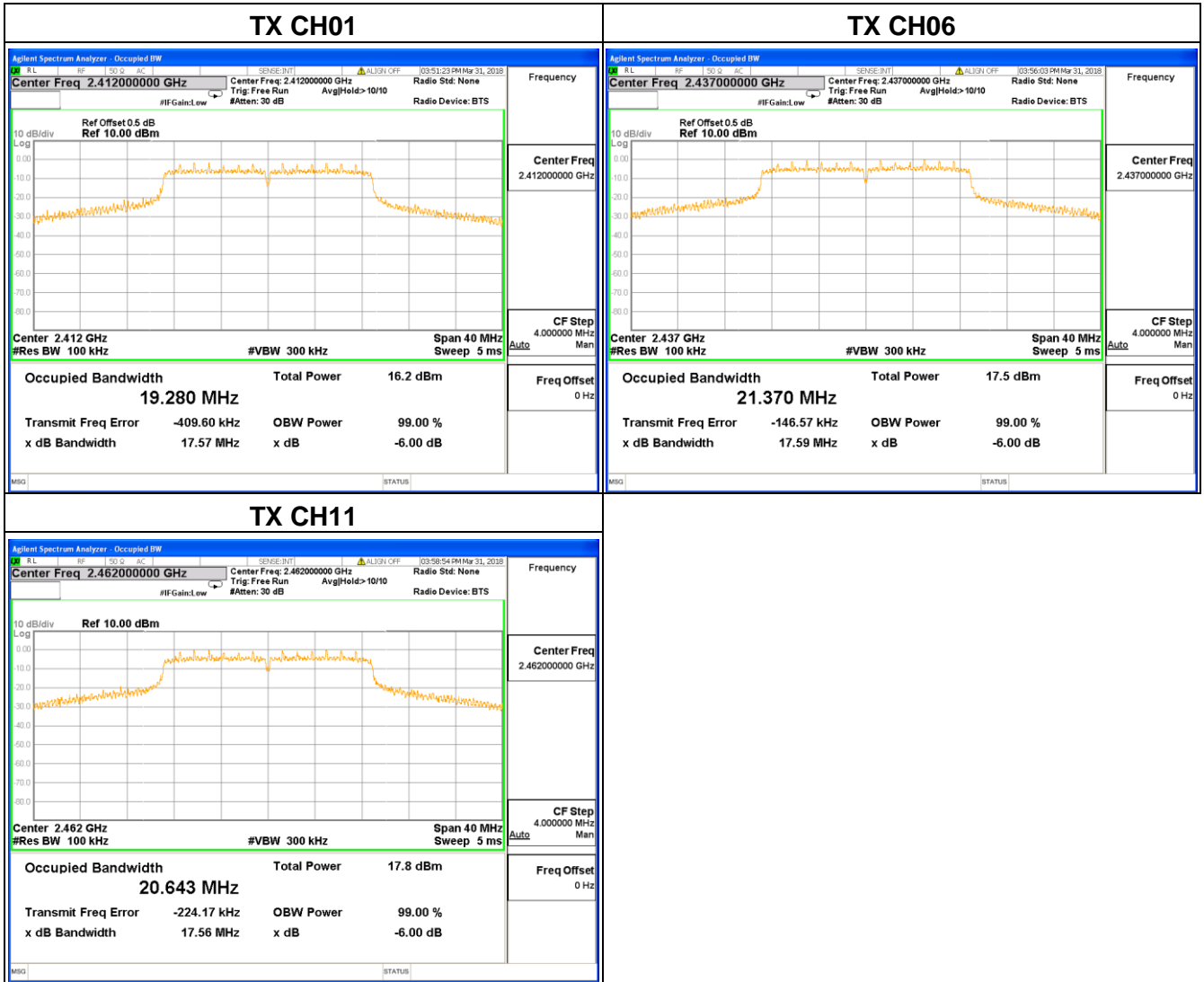

This test report is valid for the tested samples only. It cannot be reproduced except in full without prior written consent of Shenzhen Microtest Co., Ltd.

For 802.11n40

ANTA

Test Channel	Frequency (MHz)	6dB bandwidth (MHz)	Limit (kHz)	Result
CH03	2422	36.42	500	Pass
CH06	2437	36.43	500	Pass
CH09	2452	36.42	500	Pass

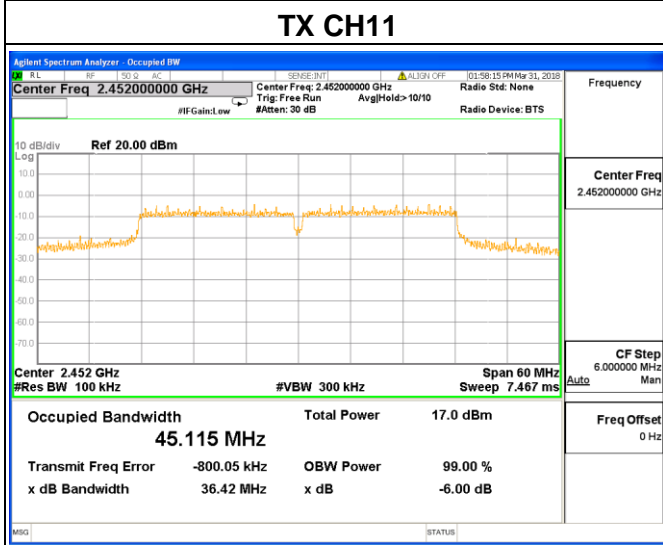
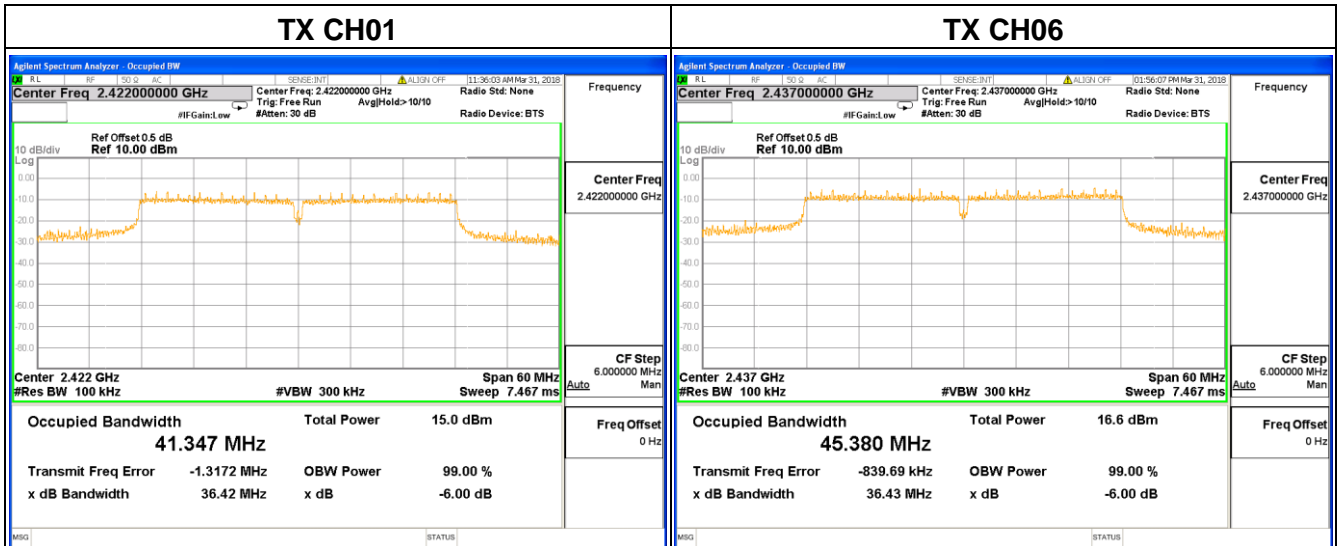

This test report is valid for the tested samples only. It cannot be reproduced except in full without prior written consent of Shenzhen Microtest Co., Ltd.

ANTB

Test Channel	Frequency (MHz)	6dB bandwidth (MHz)	Limit (kHz)	Result
CH03	2422	36.41	500	Pass
CH06	2437	36.42	500	Pass
CH09	2452	36.40	500	Pass

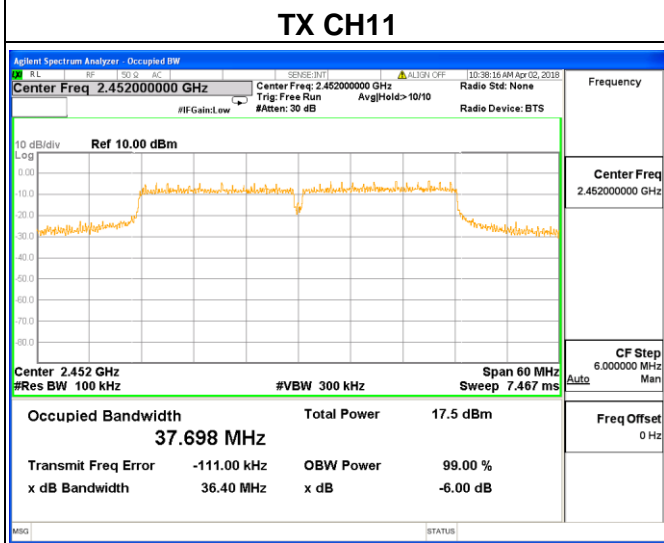
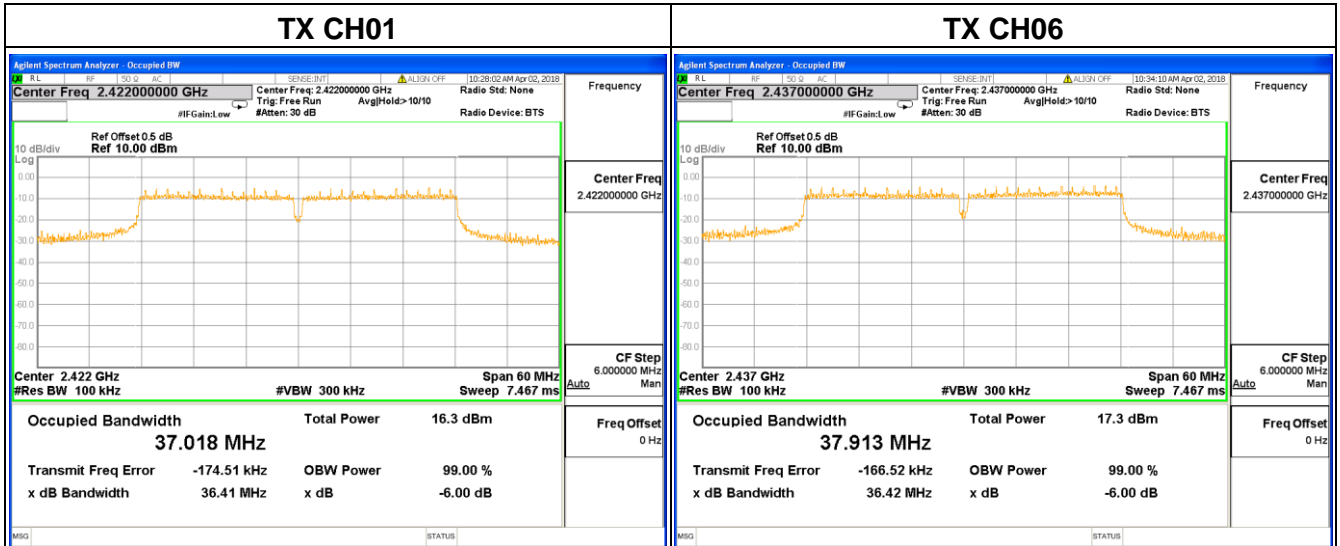

This test report is valid for the tested samples only. It cannot be reproduced except in full without prior written consent of Shenzhen Microtest Co., Ltd.

Photographs of the Test Setup

Radiated emission

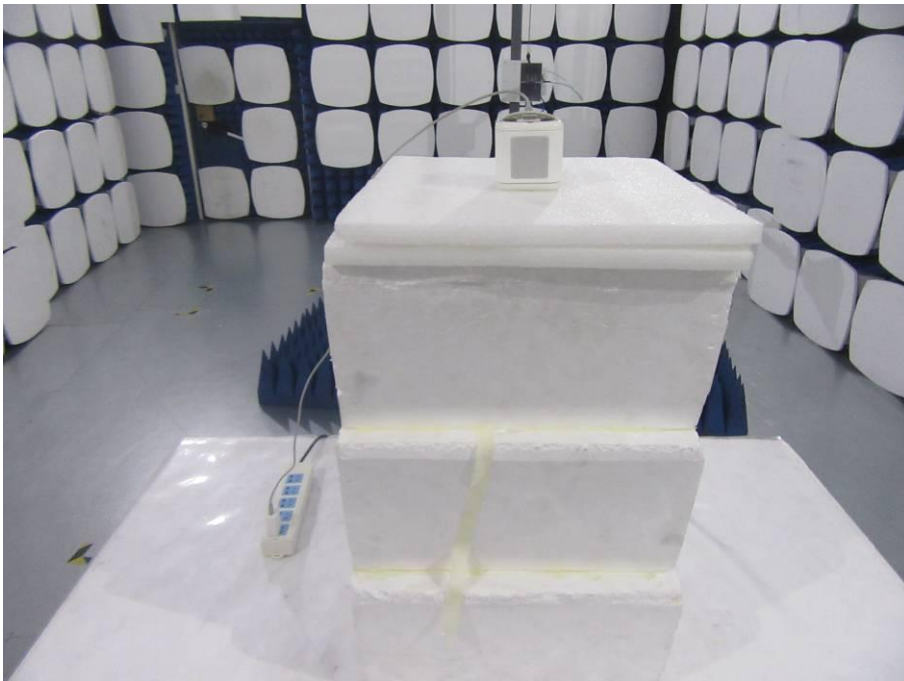
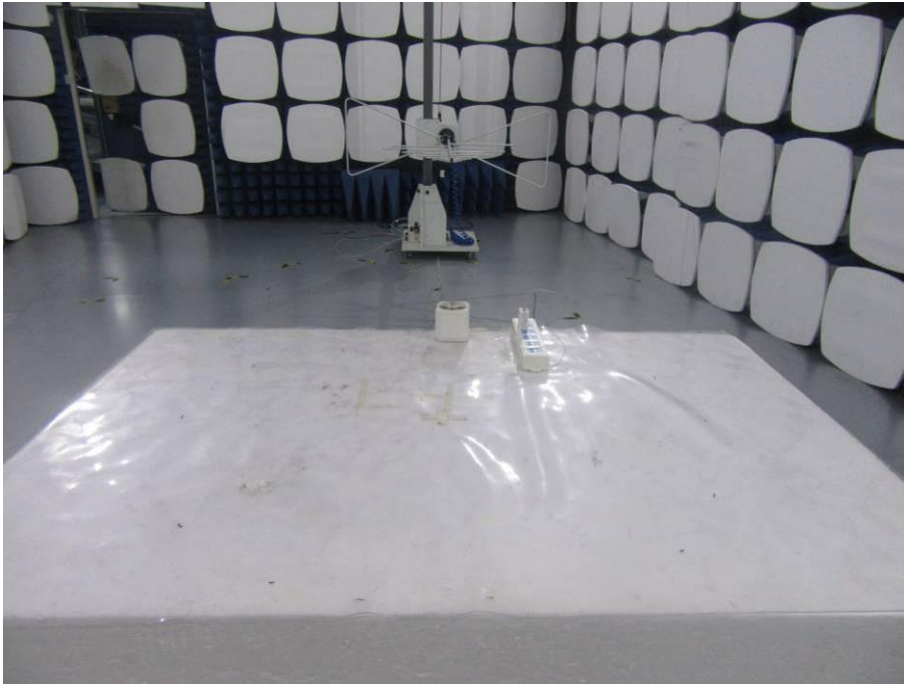

This test report is valid for the tested samples only. It cannot be reproduced except in full without prior written consent of Shenzhen Microtest Co., Ltd.

Conducted emission



----END OF REPORT----

This test report is valid for the tested samples only. It cannot be reproduced except in full without prior written consent of Shenzhen Microtest Co., Ltd.