



TEST REPORT

FCC ID: 2AF7ECIRCLE

Applicant : Circle Media Inc.
Address : 1319 SE Martin Luther King Jr. Blvd. Suite 210, Portland, OR 97214

Equipment under Test (EUT):

Name : Circle
Model : Circle Version 1

Standards : FCC PART 15, SUBPART C : 2014 (Section 15.247)
ANSI C63.4:2014 ; ANSI C63.10:2013

Report No. : T1851415 01

Date of Test : September 29, 2015- October 13, 2015

Date of Issue : October 14, 2015

Test Result :	PASS *
----------------------	---------------

* In the configuration tested, the EUT complied with the standards specified above
Authorized Signature

(Mark Zhu)
Manager

The manufacture should ensure that all the products in series production are in conformity with the product sample detailed in this report. If the product in this report is used in any configuration other than that detailed in the report, the manufacturer must ensure the new system complies with all relevant standards. Any mention of Shenzhen Alpha Product Testing Co., Ltd. Or test done by Shenzhen Alpha Product Testing Co., Ltd. Approvals in connection with, distribution or use of the product described in this report must be approved by Shenzhen Alpha Product Testing Co., Ltd. Approvals in writing.

TABLE OF CONTENT

Description	Page
1.1 Description of Device (EUT) -----	4
1.2 Description of Test Facility -----	5
2 EMC Equipment List-----	5
3 Test Procedure -----	6
4 Summary of Measurement -----	7
4.1 Summary of test result -----	7
4.2 Test connection -----	7
4.3 Assistant equipment used for test -----	8
4.4 Test mode-----	8
4.5 Channel list-----	8
4.6 Test Conditions -----	9
4.7 Measurement Uncertainty (95% confidence levels, k=2) -----	9
5 Spurious Emission -----	10
5.1 Radiation Emission-----	10
5.1.1 Radiation Emission Limits(15.209)-----	10
5.1.2 Test Setup -----	10
5.1.3 Test Procedure -----	12
5.1.4 Test Equipment Setting For emission test Result -----	12
5.1.5 Test Condition -----	13
5.1.6 Test Result-----	13
6 POWER LINE CONDUCTED EMISSION-----	36
6.1 Conducted Emission Limits(15.207)-----	36
6.2 Test Setup -----	36
6.3 Test Procedure -----	37
6.4 Test Results -----	37
7 Conducted Maximum Output Power -----	42
7.1 Test limit-----	42
7.2 Test Procedure -----	42
7.3 Test Setup -----	42
7.4 Test Results -----	42
8 PEAK POWER SPECTRAL DENSITY -----	44
8.1 Test limit-----	44
8.2 Method of measurement -----	44
8.3 Test Setup -----	44
8.4 Test Results -----	45
9 Bandwidth-----	58
9.1 Test limit-----	58
9.2 Method of measurement -----	58
9.3 Test Setup -----	58
9.4 Test Results -----	58
10 Band Edge Check-----	66
10.1 Test limit-----	66

10.2	Test Procedure	66
10.3	Test Setup	66
10.4	Test Result	66
11	Antenna Requirement	83
11.1	Standard Requirement	83
11.2	Antenna Connected Construction	83
11.3	Result	83
12	Photographs of EUT	84

1 General Information

1.1 Description of Device (EUT)

Trade Name : N/A

EUT : Circle

Model No. : Circle Version 1

DIFF : N/A

Antenna Type : Integrated Antenna, 2PCS of Maximum Gain 5dBi per antenna
Directional gain of MIMO mode is $5+10\log_2=8.01$ dBi

Operation : IEEE 802.11b/g: 2412MHz-2462MHz (SISO mode)
Frequency : IEEE 802.11n HT20: 2412MHz-2462MHz (MIMO mode)
IEEE 802.11n HT40: 2422MHz-2452MHz (MIMO mode)
EEE 802.11b/g: 11Channels

Channel number : IEEE 802.11n HT20: 11 Channels
IEEE 802.11n HT40: 7Channels
IEEE 802.11b: DSSS(CCK,DQPSK,DBPSK)

Modulation type : IEEE 802.11g: OFDM(64QAM, 16QAM, QPSK, BPSK)
IEEE 802.11n :OFDM(64QAM, 16QAM, QPSK, BPSK)

Power Supply : DC 5V from adapter or DC 3.7V from battery

Adapter : LFS05200D-A8S

Applicant : Circle Media Inc.

Address : 1319 SE Martin Luther King Jr. Blvd. Suite 210, Portland, OR 97214

Manufacture : Circle Media Inc.

Address : 1319 SE Martin Luther King Jr. Blvd. Suite 210, Portland, OR 97214

1.2 Description of Test Facility

Shenzhen Alpha Product Testing Co., Ltd
 Building B, East Area of Nanchang Second, Industrial Zone, Gushu 2nd Road,
 Bao'an, Shenzhen, China

August 11, 2014 File on Federal Communication Commission
 Registration Number: 203110

July 18, 2014 Certificated by IC
 Registration Number: 12135A

2 EMC Equipment List

Equipment	Manufacture	Model No.	Serial No.	Last cal.	Cal Interval
3m Semi-Anechoic	ETS-LINDGREN	N/A	SEL0017	2015.01.19	1Year
Spectrum analyzer	Agilent	E4407B	MY46185649	2015.01.19	1Year
Receiver	R&S	ESCI	1166.5950K03-1011	2015.01.19	1Year
Receiver	R&S	ESCI	101202	2015.01.19	1Year
Bilog Antenna	Schwarzbeck	VULB 9168	VULB9168-438	2015.01.21	1Year
Horn Antenna	EMCO	3115	640201028-06	2015.01.21	1Year
Active Loop Antenna	Beijing Daze	ZN30900A	SEL0097	2015.01.21	1Year
Cable	Resenberger	N/A	No.1	2015.01.19	1Year
Cable	SCHWARZBECK	N/A	No.2	2015.01.19	1Year
Cable	SCHWARZBECK	N/A	No.3	2015.01.19	1Year
Pre-amplifier	Schwarzbeck	BBV9743	9743-019	2015.01.19	1Year
Pre-amplifier	R&S	AFS33-18002650-30-8P-44	SEL0080	2015.01.19	1Year
Base station	Agilent	E5515C	GB44300243	2015.01.19	1 Year
Temperature controller	Terchy	MHQ	120	2015.01.19	1Year

Power divider	Anritsu	K240C	020346	2015.01.19	1 Year
Signal Generator	HP	83732B	VS3449051	2015.01.19	1 Year
Power Meter	Anritsu	ML2487A	6K00001491	2015.01.19	1Year
Power sensor	Anritsu	ML2491A	32516	2015.01.19	1Year
L.I.S.N.#1	Schwarzbeck	NSLK8126	8126466	2016.01.19	1Year
L.I.S.N.#2	ROHDE&SCHWARZ	ENV216	101043	2016.01.19	1 Year

3 Test Procedure

POWER LINE CONDUCTED INTERFERENCE: The test procedure used was ANSI Standard ANSI C63.4:2014 using a 50 u H LISN. Both Lines were observed. The bandwidth of the receiver was 10kHz with an appropriate sweep speed. The ambient temperature of the EUT was 25°C with a humidity of 58%.

RADIATION INTERFERENCE: The test procedure used was ANSI Standard ANSI C63.4:2014 using a ANRITSU spectrum analyzer with a pre-selector. The analyzer was calibrated in dB above a micro volt at the output of the antenna. The resolution bandwidth was 100kHz and the video bandwidth was 300 kHz up to 1 GHz and 1 MHz with a video BW of 3MHz above 1 GHz. The ambient temperature of the EUT was 25°C with a humidity of 58%.

FORMULA OF CONVERSION FACTORS: The Field Strength at 3m was established by adding the meter reading of the spectrum analyzer (which is set to read in units of dBuV) to the antenna correction factor supplied by the antenna manufacturer and cable loss. The antenna correction factors and cable loss are stated in terms of dB. The gain of the Pre-selector was accounted for in the Spectrum Analyzer Meter Reading.

Example:

Freq (MHz) METER READING + ACF + CABLE = FS

33.20 dBuV + 10.36 dB + 0.9 dB= 44.46 dBuV/m @ 3m

ANSI STANDARD ANSI C63.4:2014 10.1.7 MEASUREMENT PROCEDURES: The EUT was placed on a table 80 cm high and with dimensions of 1m by 1.5m. The EUT was placed in the center of the table (1.5m side). The table used for radiated measurements is capable of continuous rotation. When an emission was found, the table was rotated to produce the maximum signal strength. At this point, the antenna was raised and lowered from 1m to 4m. The antenna was placed in both the horizontal and vertical planes. The situation was similar for the conducted measurement except that the table did not rotate. The EUT was setup as described in ANSI Standard ANSI C63.4:2014 10.1.7 with the EUT 40 cm from the vertical ground wall.

4 Summary of Measurement

4.1 Summary of test result

Test Item	Test Requirement	Standards Paragraph	Result
Spurious Emission	FCC PART 15:2014	Section 15.247&15.209	Compliance
Conduction Emission	FCC PART 15:2014	Section 15.207&	Compliance
Bandwidth Test	FCC PART 15:2014	Section 15.247	Compliance
Peak Power	FCC PART 15:2014	Section 15.247	Compliance
Power Density	FCC PART 15:2014	Section 15.247	Compliance
Band Edge	FCC PART 15:2014	Section 15.247 Section 5.5	Compliance
Antenna Requirement	FCC PART 15:2014	Section 15.203	Compliance

Note: The EUT has been tested as an independent unit. And Continual Transmitting in maximum power (The adapter be used during Test)

4.2 Test connection

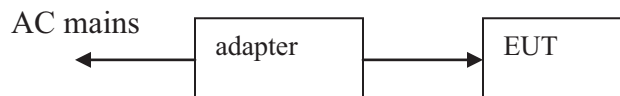

4.3 Assistant equipment used for test

Description	:	adapter
Manufacturer	:	N/A
Model No.	:	LFS05200D-A8S
Ratings	:	Input: 100-240VAC, 50/60Hz, 0.4A Max Output: 5.0VDC, 2.0A
FCC DoC Approved		

4.4 Test mode

Dutycycle :100%			
Keeping TX			
Mode	data rate (Mbps)(see Note)	Channel	Frequency (MHz)
IEEE 802.11b	1	Low :CH1	2412
	1	Middle: CH6	2437
	1	High: CH11	2462
IEEE 802.11g	6	Low :CH1	2412
	6	Middle: CH6	2437
	6	High: CH11	2462
IEEE 802.11n/HT20 with 2.4G	6.5	Low :CH1	2412
	6.5	Middle: CH6	2437
	6.5	High: CH11	2462
IEEE 802.11n/HT40 with 2.4G	13.5	Low :CH3	2422
	13.5	Middle:CH6	2437
	13.5	High:CH9	2452
Note: According exploratory test, EUT will have maximum output power in those data rate. so those data rate were used for all test.			
Note: Only 802.11n Mode can keep in MIMO mode.			

4.5 Channel list

For IEEE 802.11b/g and IEEE 802.11n/HT20 with 2.4G					
Channel	Frequency (MHz)	Channel	Frequency (MHz)	Channel	Frequency (MHz)
CH1	2412	CH5	2432	CH9	2452
CH2	2417	CH6	2437	CH10	2457
CH3	2422	CH7	2442	CH11	2462
CH4	2427	CH8	2447		

For IEEE 802.11n/HT40 with 2.4G					
Channel	Frequency (MHz)	Channel	Frequency (MHz)	Channel	Frequency (MHz)
CH1	/	CH5	2432	CH9	2452
CH2	/	CH6	2437	/	/
CH3	2422	CH7	2442	/	/
CH4	2427	CH8	2447	/	/

4.6 Test Conditions

Temperature range	21-25°C
Humidity range	40-75%
Pressure range	86-106kPa

4.7 Measurement Uncertainty (95% confidence levels, k=2)

Item	MU	Remark
Uncertainty for Power point Conducted Emissions Test	2.42dB	
Uncertainty for Radiation Emission test in 3m chamber (below 30MHz)	2.13 dB	Polarize: V
	2.57dB	Polarize: H
Uncertainty for Radiation Emission test in 3m chamber (30MHz to 1GHz)	3.54dB	Polarize: V
	4.1dB	Polarize: H
Uncertainty for Radiation Emission test in 3m chamber (1GHz to 25GHz)	2.08dB	Polarize: H
	2.56dB	Polarize: V
Uncertainty for radio frequency	1×10^{-9}	
Uncertainty for conducted RF Power	0.65dB	
Uncertainty for temperature	0.2°C	
Uncertainty for humidity	1%	
Uncertainty for DC and low frequency voltages	0.06%	

5 Spurious Emission

5.1 Radiation Emission

5.1.1 Radiation Emission Limits(15.209)

Frequencies (MHz)	Field Strength (micorvolts/meter)	Measurement Distance (meters)
0.009~0.490	2400/F(KHz)	300
0.490~1.705	24000/F(KHz)	30
1.705~30.0	30	30
30~88	100	3
88~216	150	3
216~960	200	3
Above 960	500	3

Harmonic emissions limits comply with below 54 dBuV/m at 3m. Other emissions radiated outside of the specified frequency bands, except for harmonics, shall be attenuated by at least 50 dB below the level of the fundamental or comply with the radiated emissions limits specified in section 15.209(a) limit in the table below has to be followed.

NOTE:

- a) The tighter limit applies at the band edges.
- b) Emission Level(dB uV/m)=20log Emission Level(uv/m)

5.1.2 Test Setup

See the next page

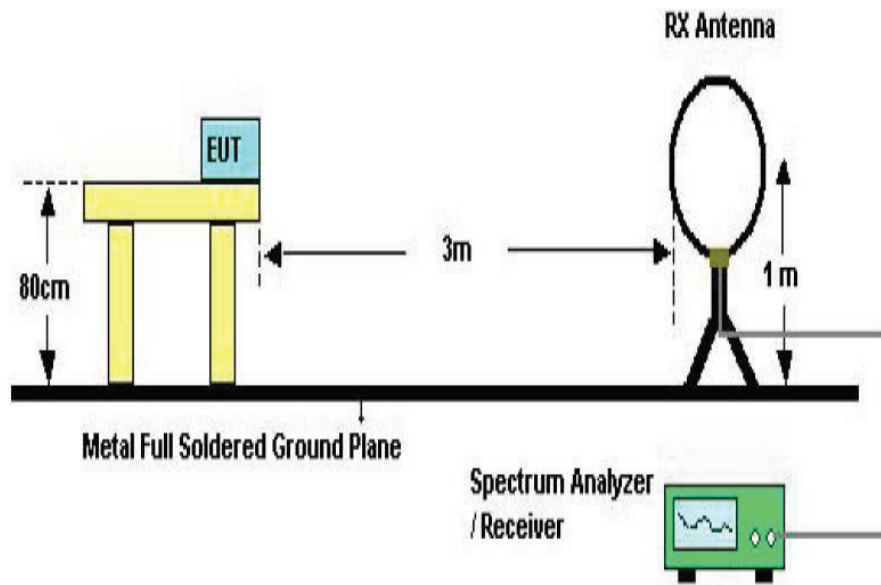

Below 30MHz Test Setup

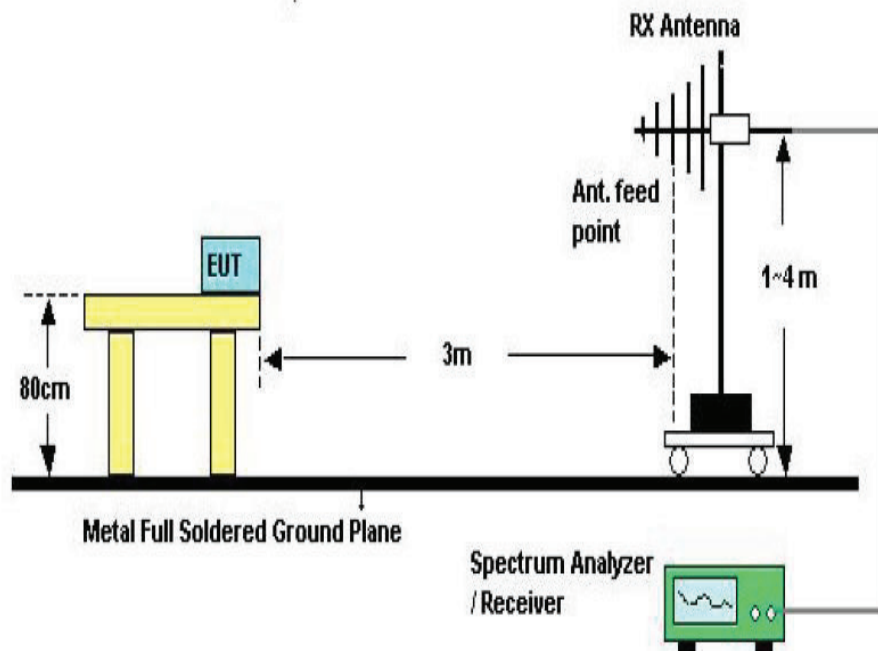

Above 30MHz Test Setup

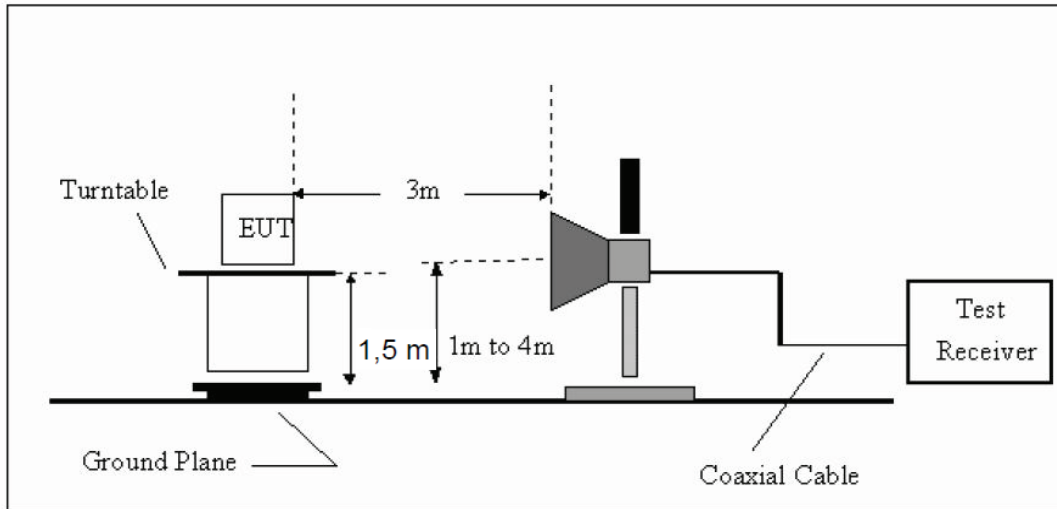

Above 1GHz Test Setup

5.1.3 Test Procedure

- The measuring distance of 3m shall be used for measurements at frequency up to 1GHz and above 1GHz, The EUT was placed on a rotating 0.8 m high above ground for below 1GHz and 1.5m high for above1GHz testing, The table was rotated 360 degrees to determine the position of the highest radiation
- The Test antenna shall vary between 1m and 4m,Both Horizontal and Vertical antenna are set of make measurement.
- The initial step in collecting conducted emission data is a spectrum analyzer Peak detector mode pre-scanning the measurement frequency range. Significant Peaks are then marked. and then Qusia Peak Detector mode premeasured
- If Peak value comply with QP limit Below 1GHz.The EUT deemed to comply with QP limit. But the Peak value and average value both need to comply with applicable limit above 1GHz.
- For the actual test configuration, please see the test setup photo.

5.1.4 Test Equipment Setting For emission test Result

9KHz~150KHz	RBW 200Hz	VBW1KHz
150KHz~30MHz	RBW 9KHz	VBW 30KHz
30MHz~1GHz	RBW 120KHz	VBW 300KHz

Above 1GHz

RBW 1MHz

VBW 3MHz

5.1.5 Test Condition

Continual Transmitting in maximum power.

5.1.6 Test Result

TX MODE

All SISO and MIMO modes have been tested , and only worse case of SISO 802.11 b mode is reported only.

We have scanned the 9KHz from 25GHz to the EUT.

Detailed information please see the following page.

From 9KHz to 30MHz: Conclusion: PASS

Note: The amplitude of spurious emissions which are attenuated by more than 20dB below the permissible value has no need to be reported.

802.11b ant1:

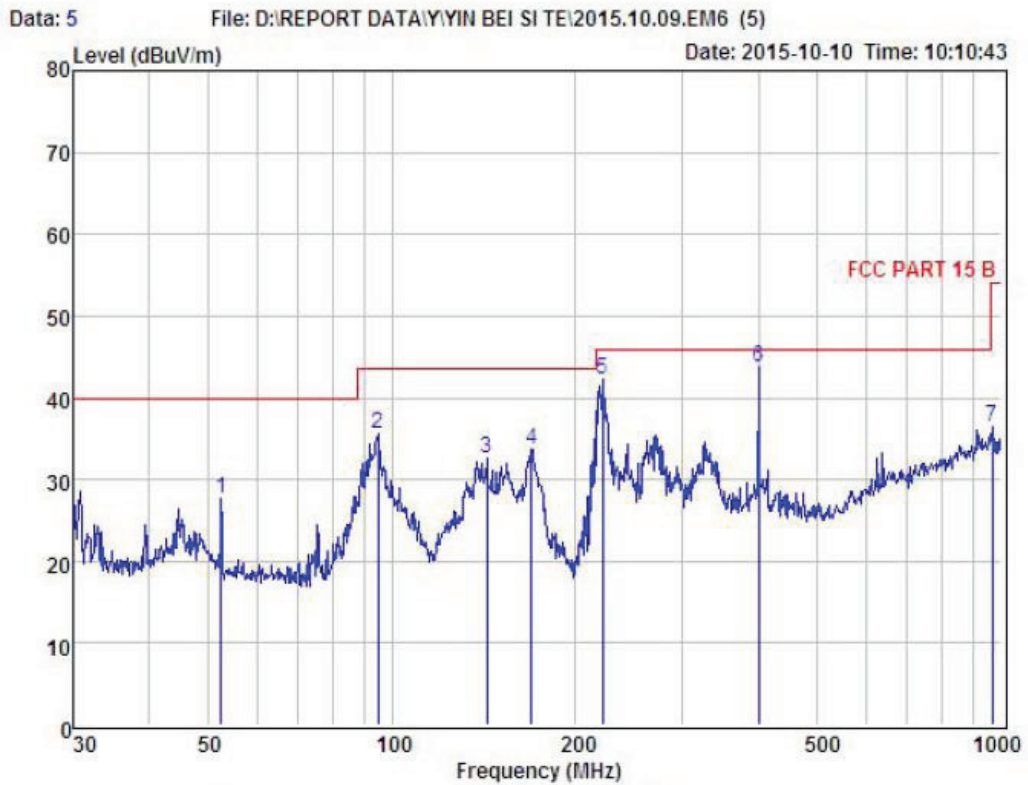

Condition : FCC PART 15 B 3m POL: HORIZONTAL
 EUI :
 Model No :
 Test Mode :
 Power : AC 120V/60Hz
 Test Engineer :
 Remark :
 Temp : 24.2°C
 Hum : 54%

Item	Freq MHz	Read Level dBuV	Antenna Factor dB	Preamp Factor dB	Cable Loss dB	Level dBuV	Limit dBuV	Margin dBuV	Remark
1	52.39	44.69	13.38	30.63	0.24	27.68	40.00	-12.32	Peak
2	94.76	55.59	9.87	30.20	0.36	35.62	43.50	-7.88	Peak
3	143.33	47.89	13.64	29.39	0.38	32.52	43.50	-10.98	Peak
4	169.60	49.01	13.18	29.12	0.59	33.66	43.50	-9.84	Peak
5	221.39	59.30	10.75	28.44	0.68	42.29	46.00	-3.71	Peak
6	400.43	55.54	14.74	27.34	0.71	43.65	46.00	-2.35	Peak
7	965.54	37.24	22.19	25.04	1.97	36.36	54.00	-17.64	Peak

Remark: Level = Read Level + Antenna Factor - Preamp Factor + Cable Loss

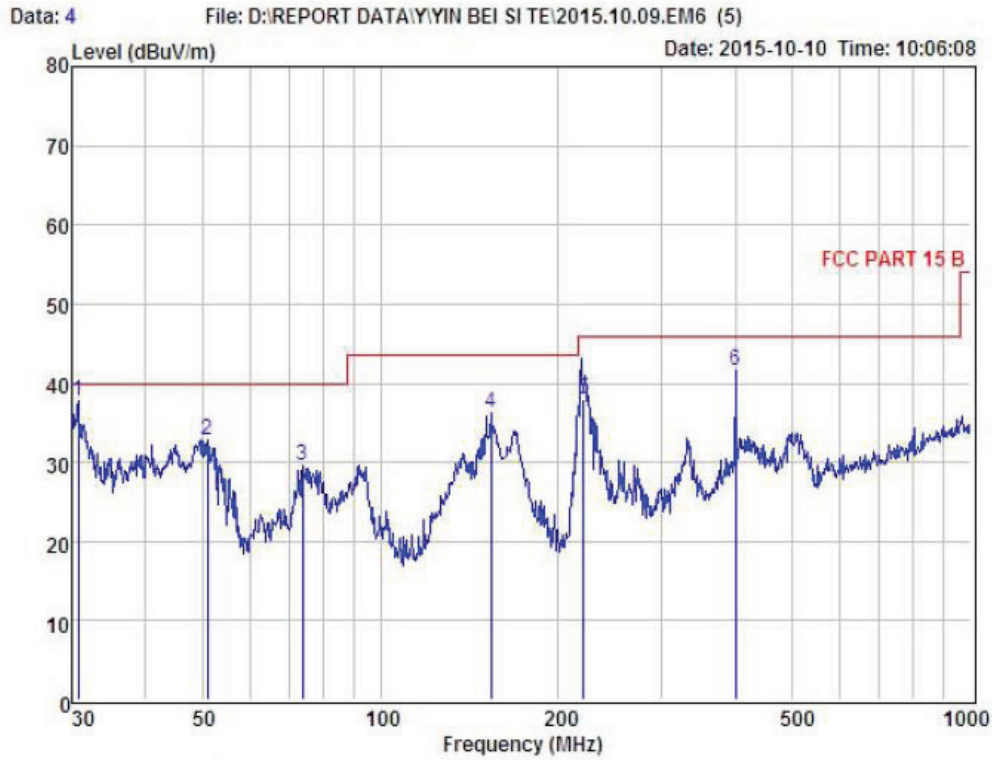

Condition : FCC PART 15 B 3m POL: VERTICAL
 EUI :
 Model No :
 Test Mode :
 Power : AC 120V/60Hz
 Test Engineer :
 Remark :
 Temp : 24.2°C
 Hum : 54%

Item	Freq MHz	Read Level dBuV	Antenna Factor dB	Preamp Factor dB	Cable Loss dB	Level dBuV	Limit dBuV	Margin dBuV	Remark
1	30.75	55.46	13.22	30.98	0.07	37.77	40.00	-2.23	Peak
2	50.94	49.58	13.38	30.39	0.25	32.82	40.00	-7.18	Peak
3	73.88	49.32	10.21	30.09	0.24	29.68	40.00	-10.32	Peak
4	153.74	51.13	14.15	29.36	0.40	36.32	43.50	-7.18	Peak
5	221.01	55.00	10.75	28.44	0.68	37.99	46.00	-8.01	QP
6	400.43	53.40	14.74	27.34	0.71	41.51	46.00	-4.49	Peak

Remark: Level = Read Level + Antenna Factor - Preamp Factor + Cable Loss

802.11b ant2:

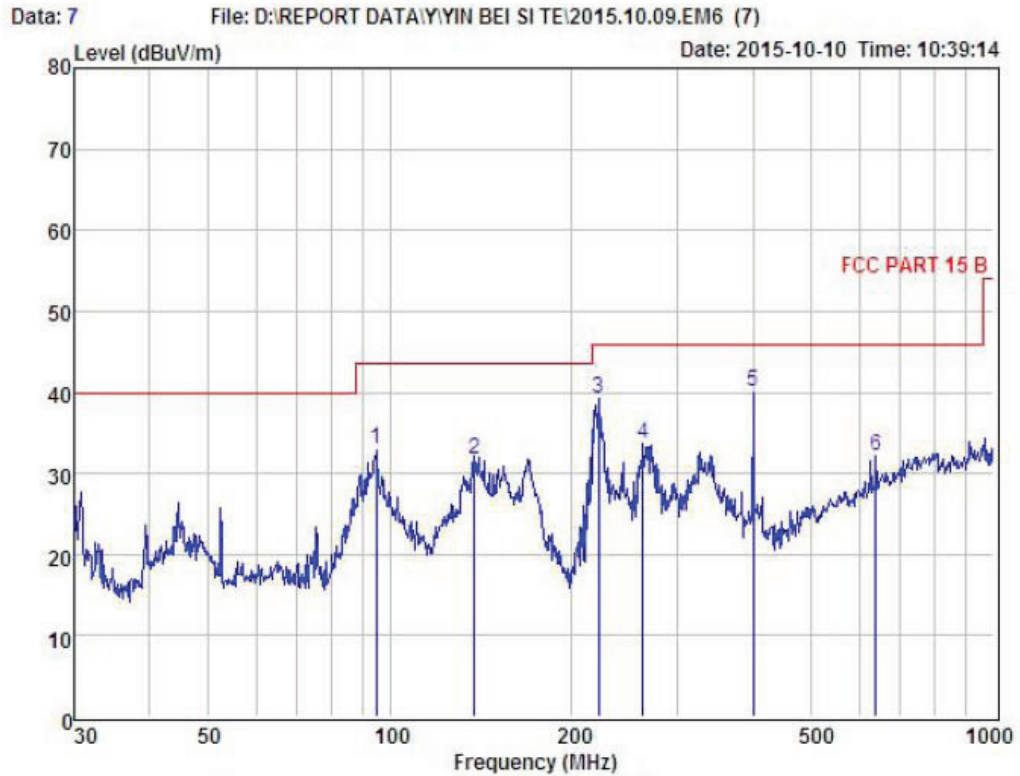

Condition : FCC PART 15 B 3m POL: HORIZONTAL
 EUT :
 Model No :
 Test Mode :
 Power : AC 120V/60Hz
 Test Engineer :
 Remark : ANT2
 Temp : 24.2°C
 Hum : 54%

Item	Freq MHz	Read Level dBuV	Antenna Factor dB	Preamp Factor dB	Cable Loss dB	Level dBuV	Limit dBuV	Margin dBuV	Remark
1	94.76	52.96	9.87	30.20	0.36	32.99	43.50	-10.51	Peak
2	137.90	47.35	13.37	29.36	0.41	31.77	43.50	-11.73	Peak
3	221.39	56.30	10.75	28.44	0.68	39.29	46.00	-6.71	Peak
4	262.90	49.29	11.90	28.17	0.73	33.75	46.00	-12.25	Peak
5	400.43	51.99	14.74	27.34	0.71	40.10	46.00	-5.90	Peak
6	638.37	37.64	18.94	25.59	1.22	32.21	46.00	-13.79	Peak

Remark: Level = Read Level + Antenna Factor - Preamp Factor + Cable Loss

Data: 6 File: D:\REPORT DATA\YIN BEI SI TE\2015.10.09.EM6 (7) Date: 2015-10-10 Time: 10:30:36

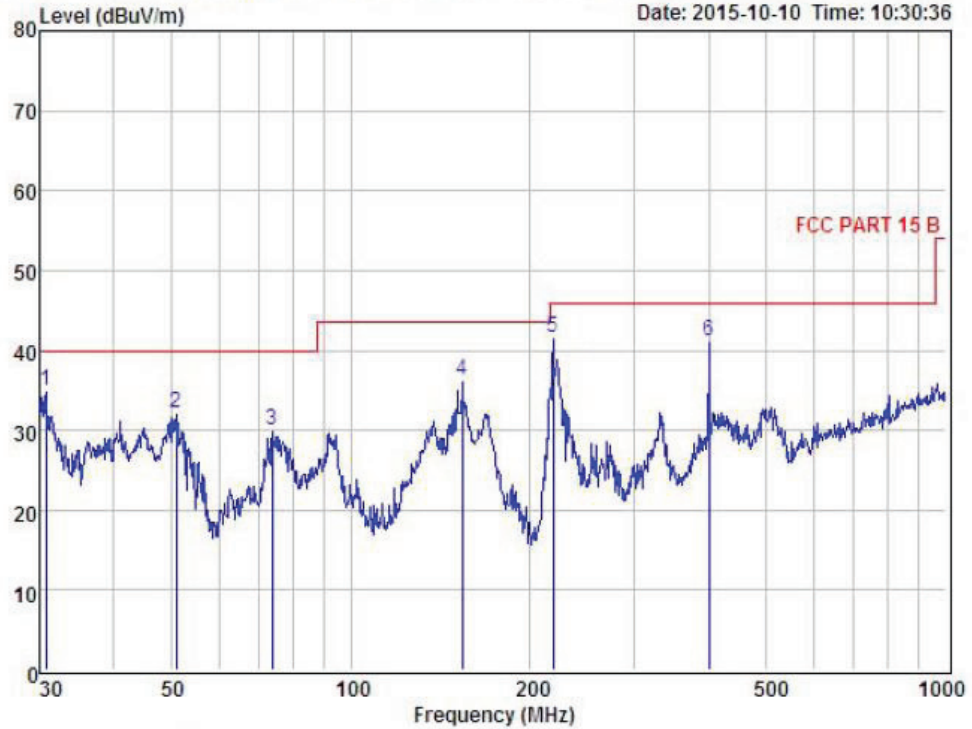

Condition : FCC PART 15 B 3m POL: VERTICAL
 EUT :
 Model No :
 Test Mode :
 Power : AC 120V/60Hz
 Test Engineer :
 Remark : ANT2
 Temp : 24.2°C
 Hum : 54%

Item	Freq MHz	Read Level dBuV	Antenna Factor dB	Preamp Factor dB	Cable Loss dB	Level dBuV	Limit dBuV	Margin dBuV	Remark
1	30.75	52.69	13.22	30.98	0.07	35.00	40.00	-5.00	Peak
2	50.94	48.97	13.38	30.39	0.25	32.21	40.00	-7.79	Peak
3	73.88	49.66	10.21	30.09	0.24	30.02	40.00	-9.98	Peak
4	153.74	50.96	14.15	29.36	0.40	36.15	43.50	-7.35	Peak
5	219.08	58.69	10.64	28.45	0.67	41.55	46.00	-4.45	Peak
6	400.43	53.00	14.74	27.34	0.71	41.11	46.00	-4.89	Peak

Remark: Level = Read Level + Antenna Factor - Preamp Factor + Cable Loss

From 1G-25GHz

EUT	Circle	Model Name	Circle Version 1
Temperature	26°C	Relative Humidity	56%
Pressure	960hPa	Test voltage	DC 5V From adapter
Test Mode	TX Low		

IEEE 802.11b ant1:

Freq. (MHz)	Ant. Pol H/V	Peak Reading (dBuV)	AV Reading (dBuV)	Ant. / CL CF (dB)	Actual Fs		Peak Limit (dBuV/m)	AV Limit (dBuV/m)	Margin (dB)	Remark
					Peak (dBuV/m)	AV (dBuV/m)				
1103	V	42.14	---	-11.24	30.9	---	74	54	43.1	Peak
4824	V	34.76	---	0.64	35.4	---	74	54	38.6	Peak
N/A										

EUT	Circle	Model Name	Circle Version 1
Temperature	26°C	Relative Humidity	56%
Pressure	960hPa	Test voltage	DC 5V From adapter
Test Mode	TX Low		

Freq. (MHz)	Ant. Pol H/V	Peak Reading (dBuV)	AV Reading (dBuV)	Ant. / CL CF (dB)	Actual Fs		Peak Limit (dBuV/m)	AV Limit (dBuV/m)	Margin (dB)	Remark
					Peak (dBuV/m)	AV (dBuV/m)				
1103	H	41.91	---	-11.24	30.67	---	74	54	43.33	Peak
4824	H	34.64	---	0.64	35.28	---	74	54	38.72	Peak
N/A										

Notes: AV Means AV detector test data, Peak Means Peak detector test data.

Emissions attenuated more than 20 dB below the permissible value are not reported.

EUT	Circle	Model Name	Circle Version 1
Temperature	26°C	Relative Humidity	56%
Pressure	960hPa	Test voltage	DC 5V From adapter
Test Mode	TX Mid		

Freq. (MHz)	Ant. Pol H/V	Peak Reading (dBuV)	AV Reading (dBuV)	Ant. / CL CF (dB)	Actual Fs		Peak Limit (dBuV/m)	AV Limit (dBuV/m)	Margin (dB)	Remark
					Peak (dBuV/m)	AV (dBuV/m)				
1103	V	42.19	---	-11.24	30.95	---	74	54	43.05	Peak
4874	V	37.61	---	0.76	38.37	---	74	54	35.63	Peak

EUT	Circle	Model Name	Circle Version 1
Temperature	26°C	Relative Humidity	56%
Pressure	960hPa	Test voltage	DC 5V From adapter
Test Mode	TX Mid		

Freq. (MHz)	Ant. Pol H/V	Peak Reading (dBuV)	AV Reading (dBuV)	Ant. / CL CF (dB)	Actual Fs		Peak Limit (dBuV/m)	AV Limit (dBuV/m)	Margin (dB)	Remark
					Peak (dBuV/m)	AV (dBuV/m)				
1103	H	41.87	---	-11.24	30.63	---	74	54	43.37	Peak
4874	H	38.59	---	0.76	39.35	---	74	54	34.65	Peak

Notes: AV Means AV detector test data, Peak Means Peak detector test data.

Emissions attenuated more than 20 dB below the permissible value are not reported.

EUT	Circle	Model Name	Circle Version 1
Temperature	26°C	Relative Humidity	56%
Pressure	960hPa	Test voltage	DC 5V From adapter
Test Mode	TX High		

Freq. (MHz)	Ant. Pol H/V	Peak Reading (dBuV)	AV Reading (dBuV)	Ant. / CL CF (dB)	Actual Fs		Peak Limit (dBuV/m)	AV Limit (dBuV/m)	Margin (dB)	Remark
					Peak (dBuV/m)	AV (dBuV/m)				
1103	V	41.38	---	-11.24	30.14	---	74	54	43.86	Peak
4924	V	34.5	---	0.87	35.37	---	74	54	38.63	Peak

EUT	Circle	Model Name	Circle Version 1
Temperature	26°C	Relative Humidity	56%
Pressure	960hPa	Test voltage	DC 5V From adapter
Test Mode	TX High		

Freq. (MHz)	Ant. Pol H/V	Peak Reading (dBuV)	AV Reading (dBuV)	Ant. / CL CF (dB)	Actual Fs		Peak Limit (dBuV/m)	AV Limit (dBuV/m)	Margin (dB)	Remark
					Peak (dBuV/m)	AV (dBuV/m)				
1103	H	41.91	---	-11.24	30.67	---	74	54	43.33	Peak
4924	H	31.8	---	0.87	32.67	---	74	54	41.33	Peak

Notes: AV Means AV detector test data, Peak Means Peak detector test data.

Emissions attenuated more than 20 dB below the permissible value are not reported.

IEEE 802.11 g ant1:

EUT	Circle	Model Name	Circle Version 1
Temperature	26°C	Relative Humidity	56%
Pressure	960hPa	Test voltage	DC 5V From adapter
Test Mode	TX Low		

Freq. (MHz)	Ant. Pol H/V	Peak Reading (dBuV)	AV Reading (dBuV)	Ant. / CL CF (dB)	Actual Fs		Peak Limit (dBuV/m)	AV Limit (dBuV/m)	Margin (dB)	Remark
					Peak (dBuV/m)	AV (dBuV/m)				
1145	V	42.54	---	-11.24	31.3	---	74	54	42.7	Peak
2586	V	45.14	---	-7.13	38.01	---	74	54	35.99	Peak
3062	V	43.19	---	-5.74	37.45	---	74	54	36.55	Peak
4824	V	42.24	---	0.64	42.88	---	74	54	31.12	Peak
N/A										

EUT	Circle	Model Name	Circle Version 1
Temperature	26°C	Relative Humidity	56%
Pressure	960hPa	Test voltage	DC 5V From adapter
Test Mode	TX Low		

Freq. (MHz)	Ant. Pol H/V	Peak Reading (dBuV)	AV Reading (dBuV)	Ant. / CL CF (dB)	Actual Fs		Peak Limit (dBuV/m)	AV Limit (dBuV/m)	Margin (dB)	Remark
					Peak (dBuV/m)	AV (dBuV/m)				
1294	H	42.93	---	-10.96	31.97	---	74	54	42.03	Peak
2038	H	42.06	---	-8.58	33.48	---	74	54	40.52	Peak
3483	H	40.91	---	-4.95	35.96	---	74	54	38.04	Peak
4824	H	39.58	---	0.64	40.22	---	74	54	33.78	Peak
N/A										

Notes: AV Means AV detector test data, Peak Means Peak detector test data.

Emissions attenuated more than 20 dB below the permissible value are not reported.

EUT	Circle	Model Name	Circle Version 1
Temperature	26°C	Relative Humidity	56%
Pressure	960hPa	Test voltage	DC 5V From adapter
Test Mode	TX Mid		

Freq. (MHz)	Ant. Pol H/V	Peak Reading (dBuV)	AV Reading (dBuV)	Ant. / CL CF (dB)	Actual Fs		Peak Limit (dBuV/m)	AV Limit (dBuV/m)	Margin (dB)	Remark
					Peak (dBuV/m)	AV (dBuV/m)				
1374	V	42.3	---	-10.43	31.87	---	74	54	42.13	Peak
2589	V	42.55	---	-7.13	35.42	---	74	54	38.58	Peak
3365	V	42.09	---	-5.18	36.91	---	74	54	37.09	Peak
4874	V	41.27	---	0.76	42.03	---	74	54	31.97	Peak

EUT	Circle	Model Name	Circle Version 1
Temperature	26°C	Relative Humidity	56%
Pressure	960hPa	Test voltage	DC 5V From adapter
Test Mode	TX Mid		

Freq. (MHz)	Ant. Pol H/V	Peak Reading (dBuV)	AV Reading (dBuV)	Ant. / CL CF (dB)	Actual Fs		Peak Limit (dBuV/m)	AV Limit (dBuV/m)	Margin (dB)	Remark
					Peak (dBuV/m)	AV (dBuV/m)				
1321	H	42.13	---	-10.84	31.29	---	74	54	42.71	Peak
2314	H	42.76	---	-7.46	35.3	---	74	54	38.7	Peak
3577	H	41	---	-4.76	36.24	---	74	54	37.76	Peak
4874	H	38.9	---	0.76	39.66	---	74	54	34.34	Peak

Notes: AV Means AV detector test data, Peak Means Peak detector test data.

Emissions attenuated more than 20 dB below the permissible value are not reported.

EUT	Circle	Model Name	Circle Version 1
Temperature	26°C	Relative Humidity	56%
Pressure	960hPa	Test voltage	DC 5V From adapter
Test Mode	TX High		

Freq. (MHz)	Ant. Pol H/V	Peak Reading (dBuV)	AV Reading (dBuV)	Ant. / CL CF (dB)	Actual Fs		Peak Limit (dBuV/m)	AV Limit (dBuV/m)	Margin (dB)	Remark
					Peak (dBuV/m)	AV (dBuV/m)				
1302	V	42.1	---	-10.84	31.26	---	74	54	42.74	Peak
2982	V	42.58	---	-5.86	36.72	---	74	54	37.28	Peak
3831	V	41.63	---	-3.96	37.67	---	74	54	36.33	Peak
4924	V	39.73	---	0.87	40.6	---	74	54	33.4	Peak

EUT	Circle	Model Name	Circle Version 1
Temperature	26°C	Relative Humidity	56%
Pressure	960hPa	Test voltage	DC 5V From adapter
Test Mode	TX High		

Freq. (MHz)	Ant. Pol H/V	Peak Reading (dBuV)	AV Reading (dBuV)	Ant. / CL CF (dB)	Actual Fs		Peak Limit (dBuV/m)	AV Limit (dBuV/m)	Margin (dB)	Remark
					Peak (dBuV/m)	AV (dBuV/m)				
1446	H	41.91	---	-10.29	31.62	---	74	54	42.38	Peak
2198	H	42	---	-8.24	33.76	---	74	54	40.24	Peak
3905	H	42.13	---	-3.68	38.45	---	74	54	35.55	Peak
4924	H	39.54	---	0.87	40.41	---	74	54	33.59	Peak

Notes: AV Means AV detector test data, Peak Means Peak detector test data.

Emissions attenuated more than 20 dB below the permissible value are not reported.

IEEE 802.11b ant2: TX Low

Freq. (MHz)	Ant. Pol H/V	Peak Reading (dBuV)	AV Reading (dBuV)	Ant. / CL CF (dB)	Actual Fs		Peak Limit (dBuV/m)	AV Limit (dBuV/m)	Margin (dB)	Remark
					Peak (dBuV/m)	AV (dBuV/m)				
1103	V	40.99	---	-11.24	29.75	---	74	54	44.25	Peak
4824	V	33.37	---	0.64	34.01	---	74	54	39.99	Peak
N/A										

EUT	Circle	Model Name	Circle Version 1
Temperature	26°C	Relative Humidity	56%
Pressure	960hPa	Test voltage	DC 5V From adapter
Test Mode	TX Low		

Freq. (MHz)	Ant. Pol H/V	Peak Reading (dBuV)	AV Reading (dBuV)	Ant. / CL CF (dB)	Actual Fs		Peak Limit (dBuV/m)	AV Limit (dBuV/m)	Margin (dB)	Remark
					Peak (dBuV/m)	AV (dBuV/m)				
1103	H	40.51	---	-11.24	29.27	---	74	54	44.73	Peak
4824	H	33.1	---	0.64	33.74	---	74	54	40.26	Peak
N/A										

Notes: AV Means AV detector test data, Peak Means Peak detector test data.

Emissions attenuated more than 20 dB below the permissible value are not reported.

EUT	Circle	Model Name	Circle Version 1
Temperature	26°C	Relative Humidity	56%
Pressure	960hPa	Test voltage	DC 5V From adapter
Test Mode	TX Mid		

Freq. (MHz)	Ant. Pol H/V	Peak Reading (dBuV)	AV Reading (dBuV)	Ant. / CL CF (dB)	Actual Fs		Peak Limit (dBuV/m)	AV Limit (dBuV/m)	Margin (dB)	Remark
					Peak (dBuV/m)	AV (dBuV/m)				
1103	V	39.96	---	-11.24	28.72	---	74	54	45.28	Peak
4874	V	35.7	---	0.76	36.46	---	74	54	37.54	Peak

EUT	Circle	Model Name	Circle Version 1
Temperature	26°C	Relative Humidity	56%
Pressure	960hPa	Test voltage	DC 5V From adapter
Test Mode	TX Mid		

Freq. (MHz)	Ant. Pol H/V	Peak Reading (dBuV)	AV Reading (dBuV)	Ant. / CL CF (dB)	Actual Fs		Peak Limit (dBuV/m)	AV Limit (dBuV/m)	Margin (dB)	Remark
					Peak (dBuV/m)	AV (dBuV/m)				
1103	H	40.12	---	-11.24	28.88	---	74	54	45.12	Peak
4874	H	36.7	---	0.76	37.46	---	74	54	36.54	Peak

Notes: AV Means AV detector test data, Peak Means Peak detector test data.

Emissions attenuated more than 20 dB below the permissible value are not reported.

EUT	Circle	Model Name	Circle Version 1
Temperature	26°C	Relative Humidity	56%
Pressure	960hPa	Test voltage	DC 5V From adapter
Test Mode	TX High		

Freq. (MHz)	Ant. Pol H/V	Peak Reading (dBuV)	AV Reading (dBuV)	Ant. / CL CF (dB)	Actual Fs		Peak Limit (dBuV/m)	AV Limit (dBuV/m)	Margin (dB)	Remark
					Peak (dBuV/m)	AV (dBuV/m)				
1103	V	39.91	---	-11.24	28.67	---	74	54	45.33	Peak
4924	V	31.33	---	0.87	32.2	---	74	54	41.8	Peak

EUT	Circle	Model Name	Circle Version 1
Temperature	26°C	Relative Humidity	56%
Pressure	960hPa	Test voltage	DC 5V From adapter
Test Mode	TX High		

Freq. (MHz)	Ant. Pol H/V	Peak Reading (dBuV)	AV Reading (dBuV)	Ant. / CL CF (dB)	Actual Fs		Peak Limit (dBuV/m)	AV Limit (dBuV/m)	Margin (dB)	Remark
					Peak (dBuV/m)	AV (dBuV/m)				
1103	H	40.32	---	-11.24	29.08	---	74	54	44.92	Peak
4924	H	30.17	---	0.87	31.04	---	74	54	42.96	Peak

Notes: AV Means AV detector test data, Peak Means Peak detector test data.

Emissions attenuated more than 20 dB below the permissible value are not reported.

IEEE 802.11 g ant2:

EUT	Circle	Model Name	Circle Version 1
Temperature	26°C	Relative Humidity	56%
Pressure	960hPa	Test voltage	DC 5V From adapter
Test Mode	TX Low		

Freq. (MHz)	Ant. Pol H/V	Peak Reading (dBuV)	AV Reading (dBuV)	Ant. / CL CF (dB)	Actual Fs		Peak Limit (dBuV/m)	AV Limit (dBuV/m)	Margin (dB)	Remark
					Peak (dBuV/m)	AV (dBuV/m)				
1145	V	40.79	---	-11.24	29.55	---	74	54	44.45	Peak
2586	V	42.86	---	-7.13	35.73	---	74	54	38.27	Peak
3062	V	40.92	---	-5.74	35.18	---	74	54	38.82	Peak
4824	V	40.52	---	0.64	41.16	---	74	54	32.84	Peak
N/A										

EUT	Circle	Model Name	Circle Version 1
Temperature	26°C	Relative Humidity	56%
Pressure	960hPa	Test voltage	DC 5V From adapter
Test Mode	TX Low		

Freq. (MHz)	Ant. Pol H/V	Peak Reading (dBuV)	AV Reading (dBuV)	Ant. / CL CF (dB)	Actual Fs		Peak Limit (dBuV/m)	AV Limit (dBuV/m)	Margin (dB)	Remark
					Peak (dBuV/m)	AV (dBuV/m)				
1294	H	40.13	---	-10.96	29.17	---	74	54	44.83	Peak
2038	H	40.32	---	-8.58	31.74	---	74	54	42.26	Peak
3483	H	39.22	---	-4.95	34.27	---	74	54	39.73	Peak
4824	H	38.02	---	0.64	38.66	---	74	54	35.34	Peak
N/A										

Notes: AV Means AV detector test data, Peak Means Peak detector test data.

Emissions attenuated more than 20 dB below the permissible value are not reported.

EUT	Circle	Model Name	Circle Version 1
Temperature	26°C	Relative Humidity	56%
Pressure	960hPa	Test voltage	DC 5V From adapter
Test Mode	TX Mid		

Freq. (MHz)	Ant. Pol H/V	Peak Reading (dBuV)	AV Reading (dBuV)	Ant. / CL CF (dB)	Actual Fs		Peak Limit (dBuV/m)	AV Limit (dBuV/m)	Margin (dB)	Remark
					Peak (dBuV/m)	AV (dBuV/m)				
1374	V	40.32	---	-10.43	29.89	---	74	54	44.11	Peak
2589	V	40.91	---	-7.13	33.78	---	74	54	40.22	Peak
3365	V	40.29	---	-5.18	35.11	---	74	54	38.89	Peak
4874	V	39.51	---	0.76	40.27	---	74	54	33.73	Peak

EUT	Circle	Model Name	Circle Version 1
Temperature	26°C	Relative Humidity	56%
Pressure	960hPa	Test voltage	DC 5V From adapter
Test Mode	TX Mid		

Freq. (MHz)	Ant. Pol H/V	Peak Reading (dBuV)	AV Reading (dBuV)	Ant. / CL CF (dB)	Actual Fs		Peak Limit (dBuV/m)	AV Limit (dBuV/m)	Margin (dB)	Remark
					Peak (dBuV/m)	AV (dBuV/m)				
1321	H	40.32	---	-10.84	29.48	---	74	54	44.52	Peak
2314	H	41.02	---	-7.46	33.56	---	74	54	40.44	Peak
3577	H	39.31	---	-4.76	34.55	---	74	54	39.45	Peak
4874	H	37.02	---	0.76	37.78	---	74	54	36.22	Peak

Notes: AV Means AV detector test data, Peak Means Peak detector test data.

Emissions attenuated more than 20 dB below the permissible value are not reported.

EUT	Circle	Model Name	Circle Version 1
Temperature	26°C	Relative Humidity	56%
Pressure	960hPa	Test voltage	DC 5V From adapter
Test Mode	TX High		

Freq. (MHz)	Ant. Pol H/V	Peak Reading (dBuV)	AV Reading (dBuV)	Ant. / CL CF (dB)	Actual Fs		Peak Limit (dBuV/m)	AV Limit (dBuV/m)	Margin (dB)	Remark
					Peak (dBuV/m)	AV (dBuV/m)				
1302	V	40.32	---	-10.84	29.48	---	74	54	44.52	Peak
2982	V	40.86	---	-5.86	35	---	74	54	39	Peak
3831	V	39.92	---	-3.96	35.96	---	74	54	38.04	Peak
4924	V	38.32	---	0.87	39.19	---	74	54	34.81	Peak

EUT	Circle	Model Name	Circle Version 1
Temperature	26°C	Relative Humidity	56%
Pressure	960hPa	Test voltage	DC 5V From adapter
Test Mode	TX High		

Freq. (MHz)	Ant. Pol H/V	Peak Reading (dBuV)	AV Reading (dBuV)	Ant. / CL CF (dB)	Actual Fs		Peak Limit (dBuV/m)	AV Limit (dBuV/m)	Margin (dB)	Remark
					Peak (dBuV/m)	AV (dBuV/m)				
1446	H	40.5	---	-10.29	30.21	---	74	54	43.79	Peak
2198	H	39.32	---	-8.24	31.08	---	74	54	42.92	Peak
3905	H	40.42	---	-3.68	36.74	---	74	54	37.26	Peak
4924	H	37.9	---	0.87	38.77	---	74	54	35.23	Peak

Notes: AV Means AV detector test data, Peak Means Peak detector test data.

Emissions attenuated more than 20 dB below the permissible value are not reported.

IEEE 802.11n/HT20 with 2.4G

EUT	Circle	Model Name	Circle Version 1
Temperature	26°C	Relative Humidity	56%
Pressure	960hPa	Test voltage	DC 5V From adapter
Test Mode	MIMO TX Low		

Freq. (MHz)	Ant. Pol H/V	Peak Reading (dBuV)	AV Reading (dBuV)	Ant. / CL CF (dB)	Actual Fs		Peak Limit (dBuV/m)	AV Limit (dBuV/m)	Margin (dB)	Remark
					Peak (dBuV/m)	AV (dBuV/m)				
1492	V	42.11	---	-10.27	31.84	---	74	54	42.16	Peak
2671	V	41.47	---	-6.94	34.53	---	74	54	39.47	Peak
3948	V	41.95	---	-3.68	38.27	---	74	54	35.73	Peak
4824	V	40.93	---	0.64	41.57	---	74	54	32.43	Peak
N/A										

EUT	Circle	Model Name	Circle Version 1
Temperature	26°C	Relative Humidity	56%
Pressure	960hPa	Test voltage	DC 5V From adapter
Test Mode	MIMO TX Low		

Freq. (MHz)	Ant. Pol H/V	Peak Reading (dBuV)	AV Reading (dBuV)	Ant. / CL CF (dB)	Actual Fs		Peak Limit (dBuV/m)	AV Limit (dBuV/m)	Margin (dB)	Remark
					Peak (dBuV/m)	AV (dBuV/m)				
1451	H	42.11	---	-10.27	31.84	---	74	54	42.16	Peak
2839	H	42.38	---	-6.17	36.21	---	74	54	37.79	Peak
3607	H	41.95	---	-4.52	37.43	---	74	54	36.57	Peak
4824	H	40.87	---	0.64	41.51	---	74	54	32.49	Peak
N/A										

Notes: AV Means AV detector test data, Peak Means Peak detector test data.

Emissions attenuated more than 20 dB below the permissible value are not reported.

EUT	Circle	Model Name	Circle Version 1
Temperature	26°C	Relative Humidity	56%
Pressure	960hPa	Test voltage	DC 5V From adapter
Test Mode	MIMO TX Mid		

Freq. (MHz)	Ant. Pol H/V	Peak Reading (dBuV)	AV Reading (dBuV)	Ant. / CL CF (dB)	Actual Fs		Peak Limit (dBuV/m)	AV Limit (dBuV/m)	Margin (dB)	Remark
					Peak (dBuV/m)	AV (dBuV/m)				
1262	V	41.8	---	-10.96	30.84	---	74	54	43.16	Peak
2013	V	42.24	---	-8.58	33.66	---	74	54	40.34	Peak
3798	V	41.48	---	-4.07	37.41	---	74	54	36.59	Peak
4874	V	40.6	---	0.76	41.36	---	74	54	32.64	Peak

EUT	Circle	Model Name	Circle Version 1
Temperature	26°C	Relative Humidity	56%
Pressure	960hPa	Test voltage	DC 5V From adapter
Test Mode	MIMO TX Mid		

Freq. (MHz)	Ant. Pol H/V	Peak Reading (dBuV)	AV Reading (dBuV)	Ant. / CL CF (dB)	Actual Fs		Peak Limit (dBuV/m)	AV Limit (dBuV/m)	Margin (dB)	Remark
					Peak (dBuV/m)	AV (dBuV/m)				
1511	H	41.7	---	-10.14	31.56	---	74	54	42.44	Peak
2353	H	41.86	---	-7.59	34.27	---	74	54	39.73	Peak
3266	H	42.13	---	-5.39	36.74	---	74	54	37.26	Peak
4874	H	40.87	---	0.76	41.63	---	74	54	32.37	Peak

Notes: AV Means AV detector test data, Peak Means Peak detector test data.

Emissions attenuated more than 20 dB below the permissible value are not reported.

EUT	Circle	Model Name	Circle Version 1
Temperature	26°C	Relative Humidity	56%
Pressure	960hPa	Test voltage	DC 5V From adapter
Test Mode	MIMO TX High		

Freq. (MHz)	Ant. Pol H/V	Peak Reading (dBuV)	AV Reading (dBuV)	Ant. / CL CF (dB)	Actual Fs		Peak Limit (dBuV/m)	AV Limit (dBuV/m)	Margin (dB)	Remark
					Peak (dBuV/m)	AV (dBuV/m)				
1477	V	43.13	---	-10.27	32.86	---	74	54	41.14	Peak
2703	V	42.01	---	-6.43	35.58	---	74	54	38.42	Peak
3561	V	41.9	---	-4.76	37.14	---	74	54	36.86	Peak
4924	V	40.73	---	0.87	41.6	---	74	54	32.4	Peak

EUT	Circle	Model Name	Circle Version 1
Temperature	26°C	Relative Humidity	56%
Pressure	960hPa	Test voltage	DC 5V From adapter
Test Mode	MIMO TX High		

Freq. (MHz)	Ant. Pol H/V	Peak Reading (dBuV)	AV Reading (dBuV)	Ant. / CL CF (dB)	Actual Fs		Peak Limit (dBuV/m)	AV Limit (dBuV/m)	Margin (dB)	Remark
					Peak (dBuV/m)	AV (dBuV/m)				
1503	H	41.68	---	-10.14	31.54	---	74	54	42.46	Peak
3588	H	41.98	---	-4.96	37.02	---	74	54	36.98	Peak
4153	H	41.79	---	-2.48	39.31	---	74	54	34.69	Peak
4924	H	39.84	---	0.87	40.71	---	74	54	33.29	Peak

Notes: AV Means AV detector test data, Peak Means Peak detector test data.

Emissions attenuated more than 20 dB below the permissible value are not reported.

IEEE 802.11n/HT40 with 2.4G

EUT	Circle	Model Name	Circle Version 1
Temperature	26°C	Relative Humidity	56%
Pressure	960hPa	Test voltage	DC 5V From adapter
Test Mode	MIMO TX Low		

Freq. (MHz)	Ant. Pol H/V	Peak Reading (dBuV)	AV Reading (dBuV)	Ant. / CL CF (dB)	Actual Fs		Peak Limit (dBuV/m)	AV Limit (dBuV/m)	Margin (dB)	Remark
					Peak (dBuV/m)	AV (dBuV/m)				
1551	V	42.14	---	-10.07	32.07	---	74	54	41.93	Peak
2695	V	42.01	---	-6.94	35.07	---	74	54	38.93	Peak
3463	V	41.3	---	-4.95	36.35	---	74	54	37.65	Peak
4844	V	39.89	---	0.64	40.53	---	74	54	33.47	Peak
N/A										

EUT	Circle	Model Name	Circle Version 1
Temperature	26°C	Relative Humidity	56%
Pressure	960hPa	Test voltage	DC 5V From adapter
Test Mode	MIMO TX Low		

Freq. (MHz)	Ant. Pol H/V	Peak Reading (dBuV)	AV Reading (dBuV)	Ant. / CL CF (dB)	Actual Fs		Peak Limit (dBuV/m)	AV Limit (dBuV/m)	Margin (dB)	Remark
					Peak (dBuV/m)	AV (dBuV/m)				
1542	H	41.91	---	-10.14	31.77	---	74	54	42.23	Peak
2358	H	41.77	---	-7.59	34.18	---	74	54	39.82	Peak
3096	H	42.18	---	-5.74	36.44	---	74	54	37.56	Peak
4844	H	40.58	---	0.64	41.22	---	74	54	32.78	Peak
N/A										

Notes: AV Means AV detector test data, Peak Means Peak detector test data.

Emissions attenuated more than 20 dB below the permissible value are not reported.

EUT	Circle	Model Name	Circle Version 1
Temperature	26°C	Relative Humidity	56%
Pressure	960hPa	Test voltage	DC 5V From adapter
Test Mode	MIMO TX Mid		

Freq. (MHz)	Ant. Pol H/V	Peak Reading (dBuV)	AV Reading (dBuV)	Ant. / CL CF (dB)	Actual Fs		Peak Limit (dBuV/m)	AV Limit (dBuV/m)	Margin (dB)	Remark
					Peak (dBuV/m)	AV (dBuV/m)				
1628	V	42.47	---	-9.84	32.63	---	74	54	41.37	Peak
2593	V	41.89	---	-7.13	34.76	---	74	54	39.24	Peak
3301	V	42.03	---	-5.31	36.72	---	74	54	37.28	Peak
4874	V	40.88	---	0.76	41.64	---	74	54	32.36	Peak

EUT	Circle	Model Name	Circle Version 1
Temperature	26°C	Relative Humidity	56%
Pressure	960hPa	Test voltage	DC 5V From adapter
Test Mode	MIMO TX Mid		

Freq. (MHz)	Ant. Pol H/V	Peak Reading (dBuV)	AV Reading (dBuV)	Ant. / CL CF (dB)	Actual Fs		Peak Limit (dBuV/m)	AV Limit (dBuV/m)	Margin (dB)	Remark
					Peak (dBuV/m)	AV (dBuV/m)				
1564	H	42.1	---	-10.07	32.03	---	74	54	41.97	Peak
2248	H	42.44	---	-8.13	34.31	---	74	54	39.69	Peak
3159	H	41.4	---	-5.52	35.88	---	74	54	38.12	Peak
4874	H	40.65	---	0.76	41.41	---	74	54	32.59	Peak

Notes: AV Means AV detector test data, Peak Means Peak detector test data.

Emissions attenuated more than 20 dB below the permissible value are not reported.

EUT	Circle	Model Name	Circle Version 1
Temperature	26°C	Relative Humidity	56%
Pressure	960hPa	Test voltage	DC 5V From adapter
Test Mode	MIMO TX High		

Freq. (MHz)	Ant. Pol H/V	Peak Reading (dBuV)	AV Reading (dBuV)	Ant. / CL CF (dB)	Actual Fs		Peak Limit (dBuV/m)	AV Limit (dBuV/m)	Margin (dB)	Remark
					Peak (dBuV/m)	AV (dBuV/m)				
1645	V	42.53	---	-9.84	32.69	---	74	54	41.31	Peak
2590	V	42.06	---	-7.13	34.93	---	74	54	39.07	Peak
3851	V	41.48	---	-3.84	37.64	---	74	54	36.36	Peak
4904	V	39.83	---	0.87	40.7	---	74	54	33.3	Peak

EUT	Circle	Model Name	Circle Version 1
Temperature	26°C	Relative Humidity	56%
Pressure	960hPa	Test voltage	DC 5V From adapter
Test Mode	MIMO TX High		

Freq. (MHz)	Ant. Pol H/V	Peak Reading (dBuV)	AV Reading (dBuV)	Ant. / CL CF (dB)	Actual Fs		Peak Limit (dBuV/m)	AV Limit (dBuV/m)	Margin (dB)	Remark
					Peak (dBuV/m)	AV (dBuV/m)				
1792	H	42.2	---	-9.27	32.93	---	74	54	41.07	Peak
2804	H	42.38	---	-6.17	36.21	---	74	54	37.79	Peak
3743	H	42.74	---	-4.24	38.5	---	74	54	35.5	Peak
4904	H	41.17	---	0.87	42.04	---	74	54	31.96	Peak

Notes: AV Means AV detector test data, Peak Means Peak detector test data.

Emissions attenuated more than 20 dB below the permissible value are not reported.

6 POWER LINE CONDUCTED EMISSION

6.1 Conducted Emission Limits(15.207)

Frequency MHz	Limits dB(μ V)	
	Quasi-peak Level	Average Level
0.15 -0.50	66 -56*	56 - 46*
0.50 -5.00	56	46
5.00 -30.00	60	50

Notes: 1. *Decreasing linearly with logarithm of frequency.

2. The lower limit shall apply at the transition frequencies.

3. The limit decreases in line with the logarithm of the frequency in the rang of 0.15 to 0.50 MHz.

6.2 Test Setup

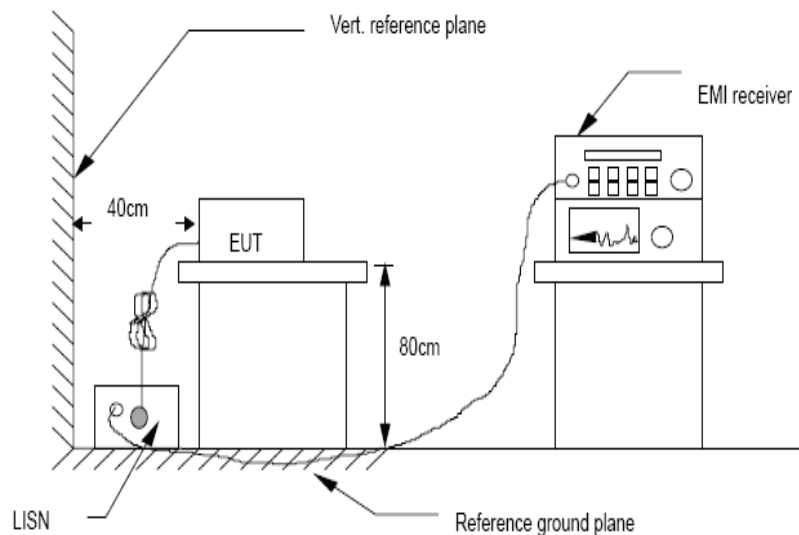

6.3 Test Procedure

The EUT is put on the plane 0.8m high above the ground by insulating support and is connected to the power mains through a line impedance stabilization network (L.I.S.N.). This provides a 50ohm coupling impedance for the EUT system. Please refer the block diagram of the test setup and photographs. Both sides of AC lines are checked to find out the maximum conducted emission. In order to find the maximum emission levels, the relative positions of equipment and all of the interface cables shall be changed according to ANSI C63.4:2014 on Conducted Emission Measurement. The bandwidth of test receiver (R & S ESCDLB ECHO 50) is set at 9 kHz.

6.4 Test Results

TX MODE

All SISO and MIMO modes have been tested , and only worse case of SISO 802.11 b mode is reported only.

PASS

Detailed information please see the following page.

802.11b ant1:

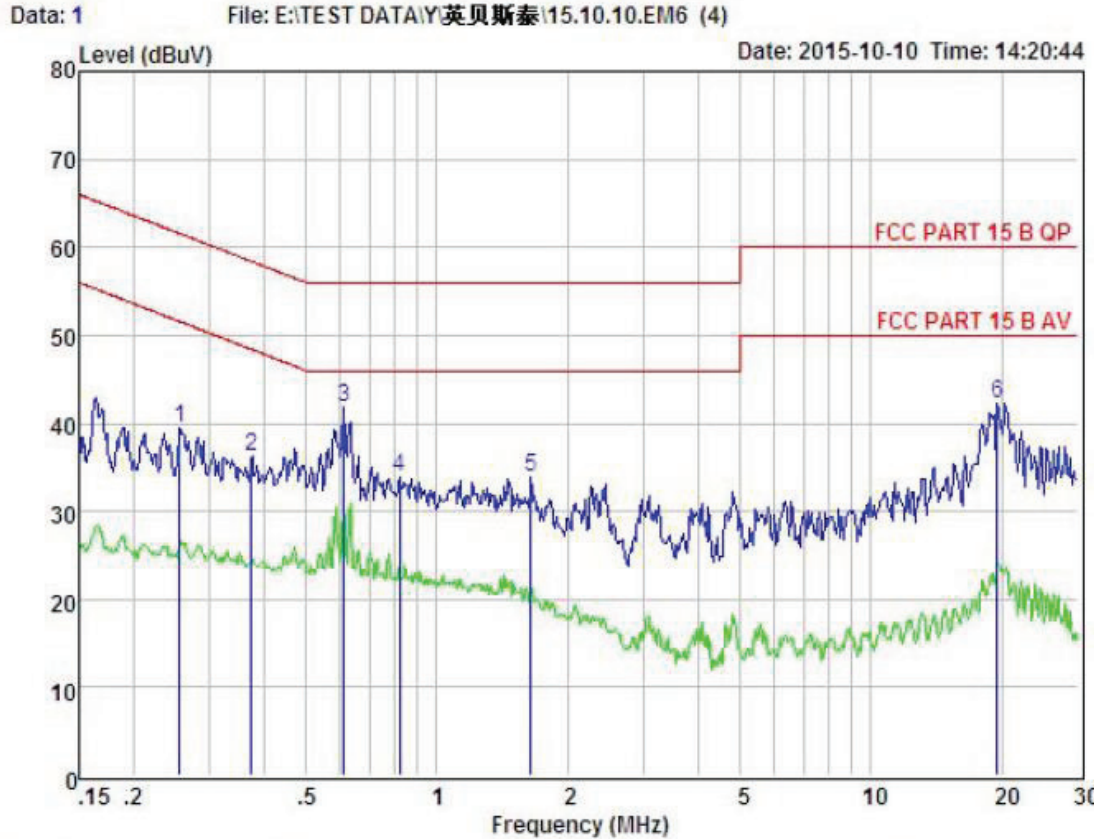

Condition : FCC PART 15 B QP POL: LINE Temp:25.7 °C Hum:51 %
 EUI :
 Model No : Circle version1
 Test Mode : Charging
 Power : AC 120V/60Hz
 Test Engineer: **
 Remark :

Item	Freq MHz	Read dBuV	LISN Factor dB	Preamp Factor dB	Cable Loss dB	Level dBuV	Limit dBuV	Margin dBuV	Remark
1	0.256	29.82	0.03	-9.56	0.10	39.51	61.55	-22.04	Peak
2	0.374	26.64	0.03	-9.57	0.10	36.34	58.40	-22.06	Peak
3	0.610	32.03	0.03	-9.59	0.10	41.75	56.00	-14.25	Peak
4	0.821	24.17	0.02	-9.60	0.10	33.89	56.00	-22.11	Peak
5	1.647	24.01	0.05	-9.69	0.10	33.85	56.00	-22.15	Peak
6	19.552	31.81	0.31	-9.80	0.34	42.26	60.00	-17.74	Peak

Remarks: Level = Read + LISN Factor - Preamp Factor + Cable loss

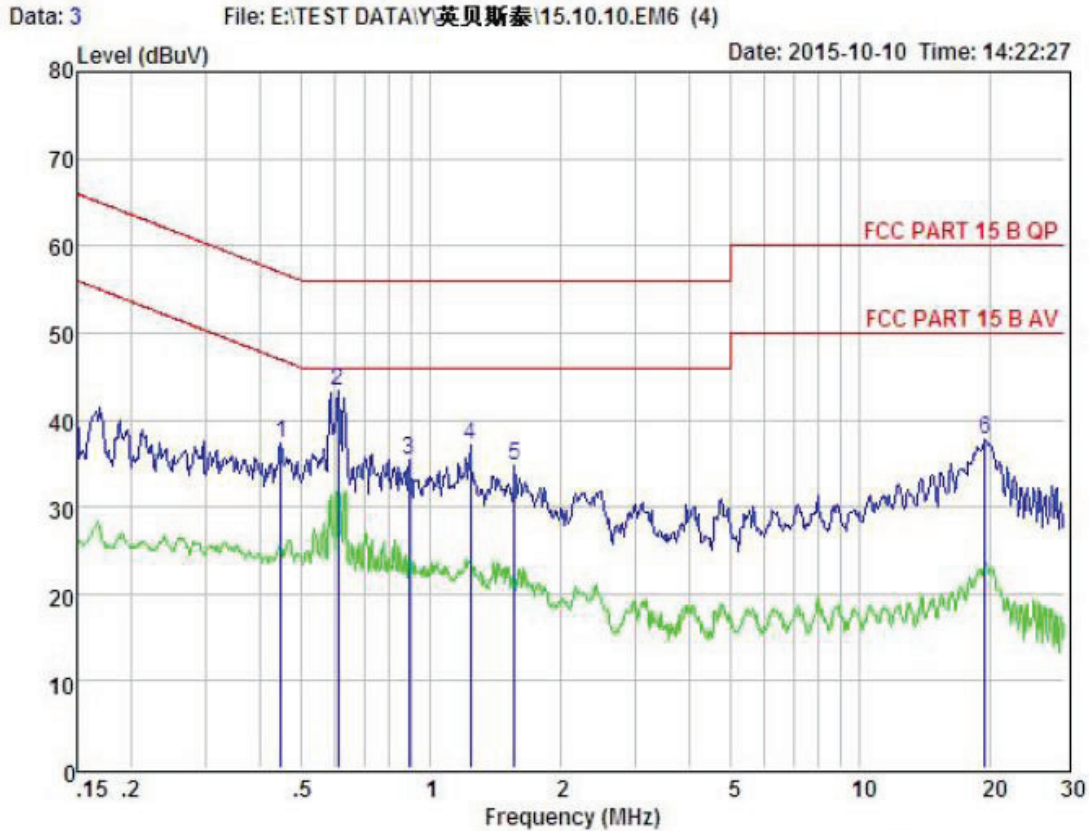

Condition : FCC PART 15 B QP POL: NEUTRAL Temp:25.7 °C Hum:51 %
 EUT :
 Model No : Circie version1
 Test Mode : Charging
 Power : AC 120V/60Hz
 Test Engineer: Alex
 Remark :

Item	Freq MHz	Read dBuV	LISN Factor dB	Preamp Factor dB	Cable Lose dB	Level dBuV	Limit dBuV	Margin dBuV	Remark
1	0.447	27.69	0.03	-9.57	0.10	37.39	56.92	-19.53	Peak
2	0.609	33.63	0.03	-9.59	0.10	43.35	56.00	-12.65	Peak
3	0.888	25.61	0.04	-9.62	0.10	35.37	56.00	-20.63	Peak
4	1.241	27.38	0.04	-9.65	0.10	37.17	56.00	-18.83	Peak
5	1.570	24.82	0.05	-9.69	0.10	34.66	56.00	-21.34	Peak
6	19.524	27.22	0.31	-9.80	0.34	37.67	60.00	-22.33	Peak

Remarks: Level = Read + LISN Factor - Preamp Factor + Cable loss

802.11b ant2

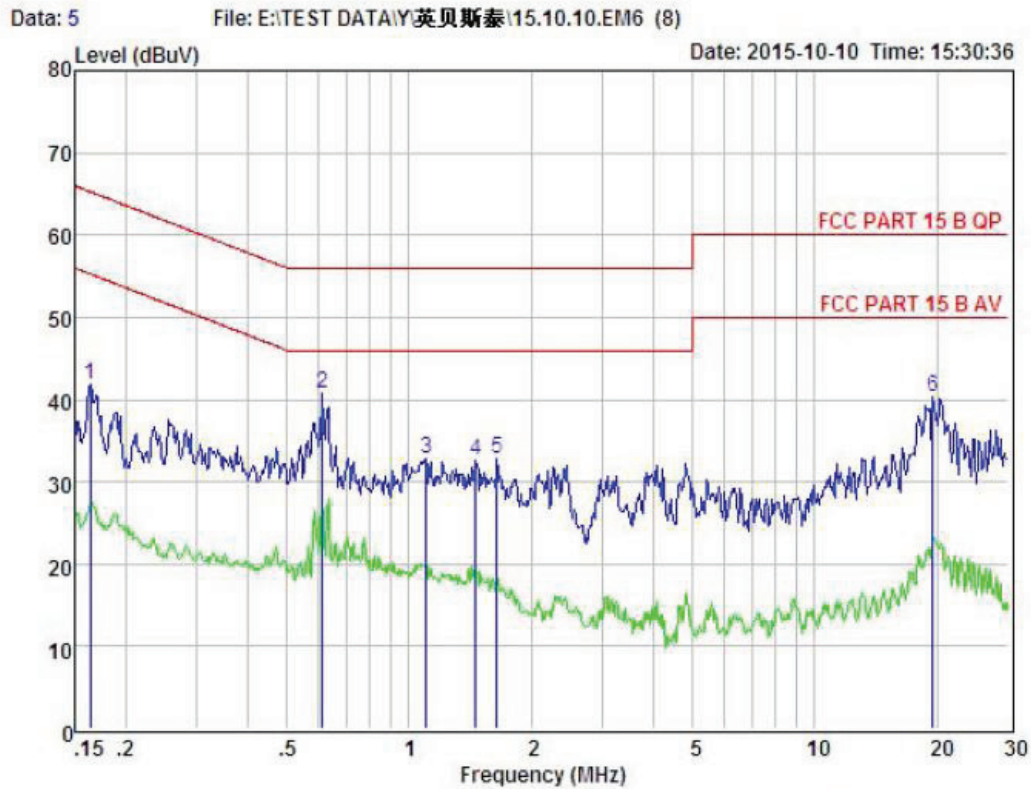

Condition : FCC PART 15 B QP POL: LINE Temp:25.7 °C Hum:51 %
 EUI :
 Model No : Circle version1
 Test Mode : Charging
 Power : AC 120V/60Hz
 Test Engineer: Alex
 Remark : ANT2

Item	Freq MHz	Read dBuV	LISN Factor dB	Preamp Factor dB	Cable Loss dB	Level dBuV	Limit dBuV	Margin dBuV	Remark
1	0.164	32.21	0.03	-9.52	0.10	41.86	65.27	-23.41	Peak
2	0.610	31.03	0.03	-9.59	0.10	40.75	56.00	-15.25	Peak
3	1.104	23.03	0.04	-9.64	0.10	32.81	56.00	-23.19	Peak
4	1.461	22.86	0.05	-9.68	0.10	32.69	56.00	-23.31	Peak
5	1.647	23.01	0.05	-9.69	0.10	32.85	56.00	-23.15	Peak
6	19.552	29.81	0.31	-9.80	0.34	40.26	60.00	-19.74	Peak

Remarks: Level = Read + LISN Factor - Preamp Factor + Cable loss