



APPLICATION SPECIFICATION

2.4 GHZ SMD ON-GROUND ANTENNA

1.0 SCOPE

This specification describes the antenna application and recommended PCB layout for the Molex 2.4 GHz SMD On-Ground Antenna. The information in this document is for reference and benchmark purposes only. The user is responsible for validating antenna RF performance based on users own PCB and matching circuits.

All measurements are done of the antenna mounted on the recommended PCB with VNA Agilent 5071C and OTA chamber.

Antenna illustrations in this document are generic representations. They are not intended to be an image of any antenna listed in the scope.

2.0 PRODUCT DESCRIPTION

A. DEFINITIONS OF TERMS

I. ANTENNA DESCRIPTION

The antenna design is based on carrier size 3mm x 3mm x 4mm. There is 1 feeding pad, 3 fixing pads and antenna radiator. See figure 1.

1. FEEDING PAD

SMD mounted to feeding pad on PCB. The signal from the transmission line must feed into the feeding pad on the PCB.

2. FIXING PAD

SMD mounted to dummy pads on PCB. Anchoring the antenna to the PCB

3. ANTENNA RADIATOR

To act as a transducer that converts unguided electromagnetic wave to guided electromagnetic wave and vice versa.

4. PICK AND PLACE FEATURE

To enable the antenna to be picked up by SMT machine pick up nozzle.

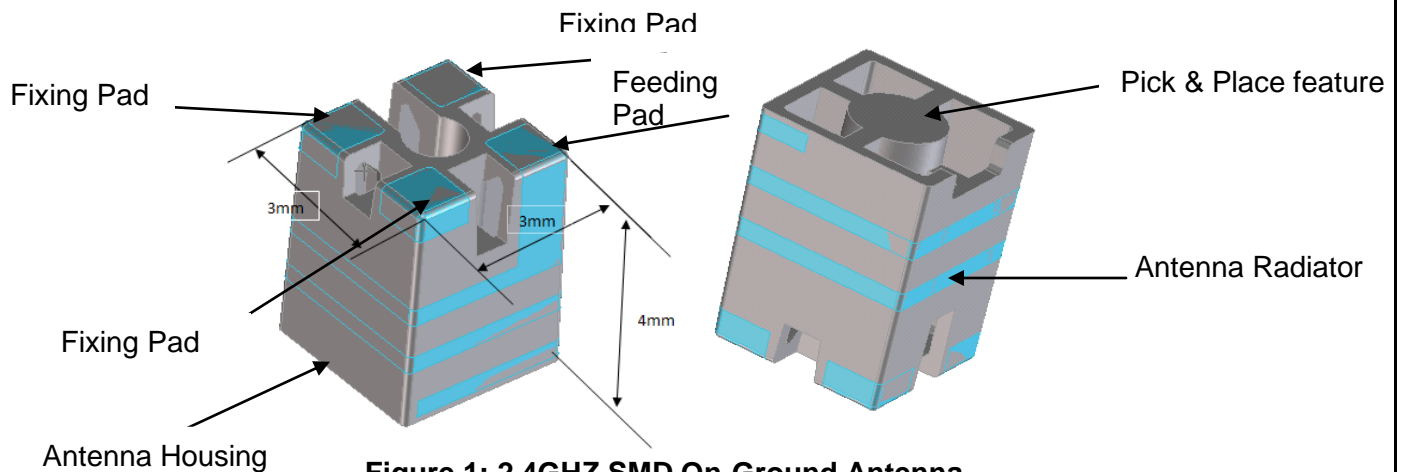

Figure 1: 2.4GHZ SMD On-Ground Antenna

REVISION: C	ECR/ECN INFORMATION: EC No: ABU2016-0022 DATE: 2015 / 8 / 28	TITLE: 2.4 GHz SMD On Ground Antenna Application Specification	SHEET No. 1 of 14
DOCUMENT NUMBER: AS-47948-001	CREATED / REVISED BY: Benson Liu	CHECKED BY: Ryan Liu	APPROVED BY: Welson Tan



APPLICATION SPECIFICATION

B. RF SPECIFICATION OF REFERENCE IMPLEMENTATION

DESCRIPTION	TEST CONDITION	REQUIREMENT
Frequency Range	Measure antenna on recommended PCB through VNA E5071C	2400MHz-2483.5MHz
Return Loss	Measure antenna on recommended PCB through VNA E5071C	< -7 dB
Peak Gain	Measure antenna on recommended PCB through OTA chamber	3.0dBi
Avg. Total Efficiency	Measure antenna on recommended PCB through OTA chamber	Average 70%
Polarization	Measure antenna through the OTA chamber	Linear
Input Impedance	Measure antenna on recommended PCB through VNA E5071C	50Ohms

TABLE 1: Antenna Specification Using Reference Board

3.0 PROCEDURE

3.1 GENERAL REQUIREMENTS

A. REFERENCE IMPLEMENTATION

I. REFERENCE PCB DESCRIPTION

The reference design is based on a recommended double sided PCB size of 100 mm x 40 mm x 1 mm. There is 1 feeding pad, 3 fixing pads, and there is a signal matching network near to feeding pad. See figure 2 and 3.

1. FEEDING PAD

The signal from transmission line must feed into the feeding pad.

2. MATCHING CIRCUIT

Recommended to reserve PCB space for a matching circuit in case it should be needed to adjust the return loss due to loading by the device housing and surrounding components.

REVISION: C	ECR/ECN INFORMATION: EC No: ABU2016-0022 DATE: 2015 / 8 / 28	TITLE: 2.4 GHz SMD On Ground Antenna Application Specification	SHEET No. 2 of 14
DOCUMENT NUMBER: AS-47948-001	CREATED / REVISED BY: Benson Liu	CHECKED BY: Ryan Liu	APPROVED BY: Welson Tan

II. REFERENCE PCB LAYOUT

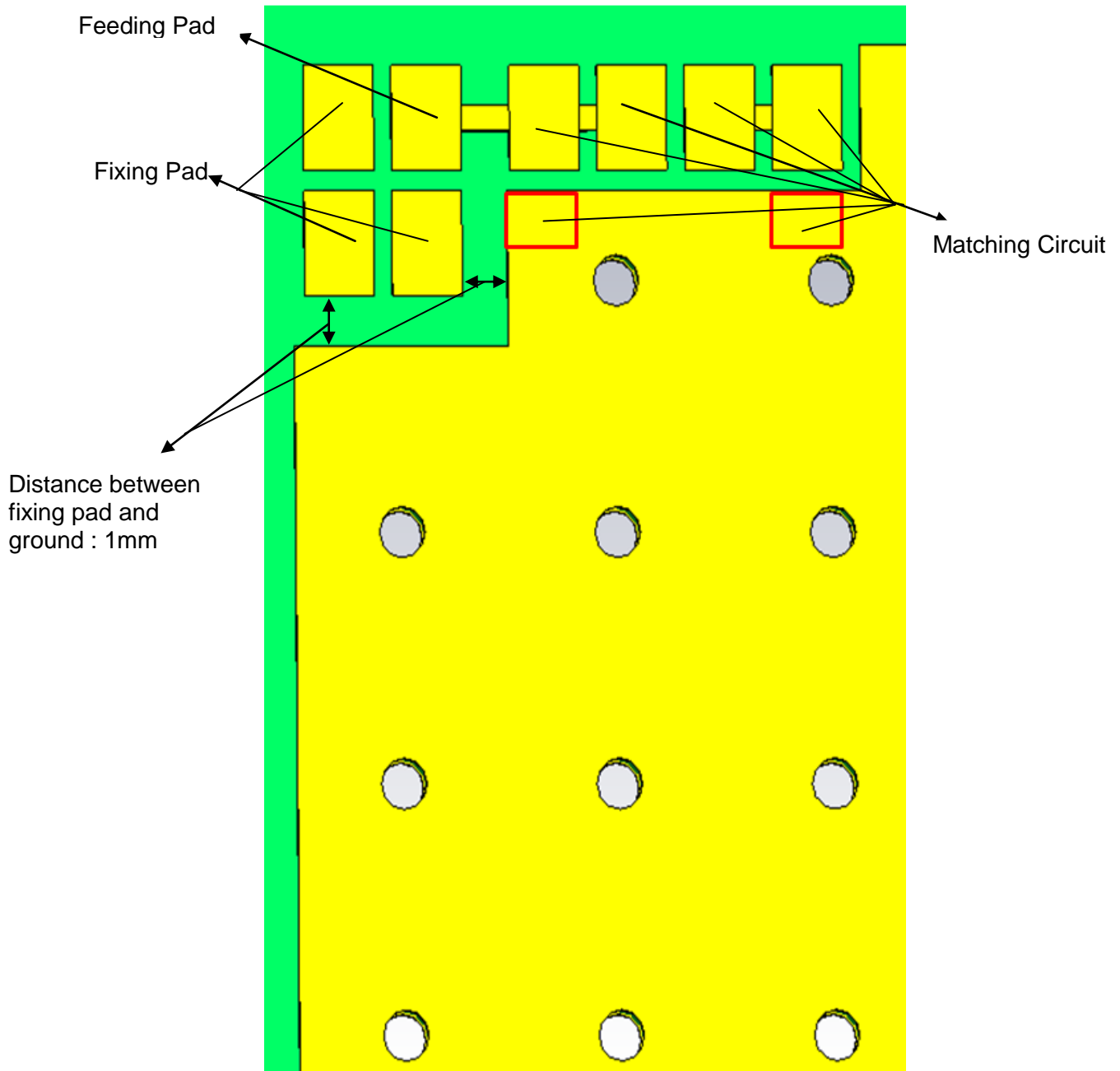

FIGURE 2: RECOMMENDED PCB LAYOUT

Note: PCB size of 100 mm x 40 mm

<u>REVISION:</u> C	<u>ECR/ECN INFORMATION:</u> EC No: ABU2016-0022 DATE: 2015 / 8 / 28	<u>TITLE:</u> 2.4 GHz SMD On Ground Antenna Application Specification	<u>SHEET No.</u> 3 of 14
<u>DOCUMENT NUMBER:</u> AS-47948-001	<u>CREATED / REVISED BY:</u> Benson Liu	<u>CHECKED BY:</u> Ryan Liu	<u>APPROVED BY:</u> Welson Tan

III. REFERENCE ANTENNA LOCATION

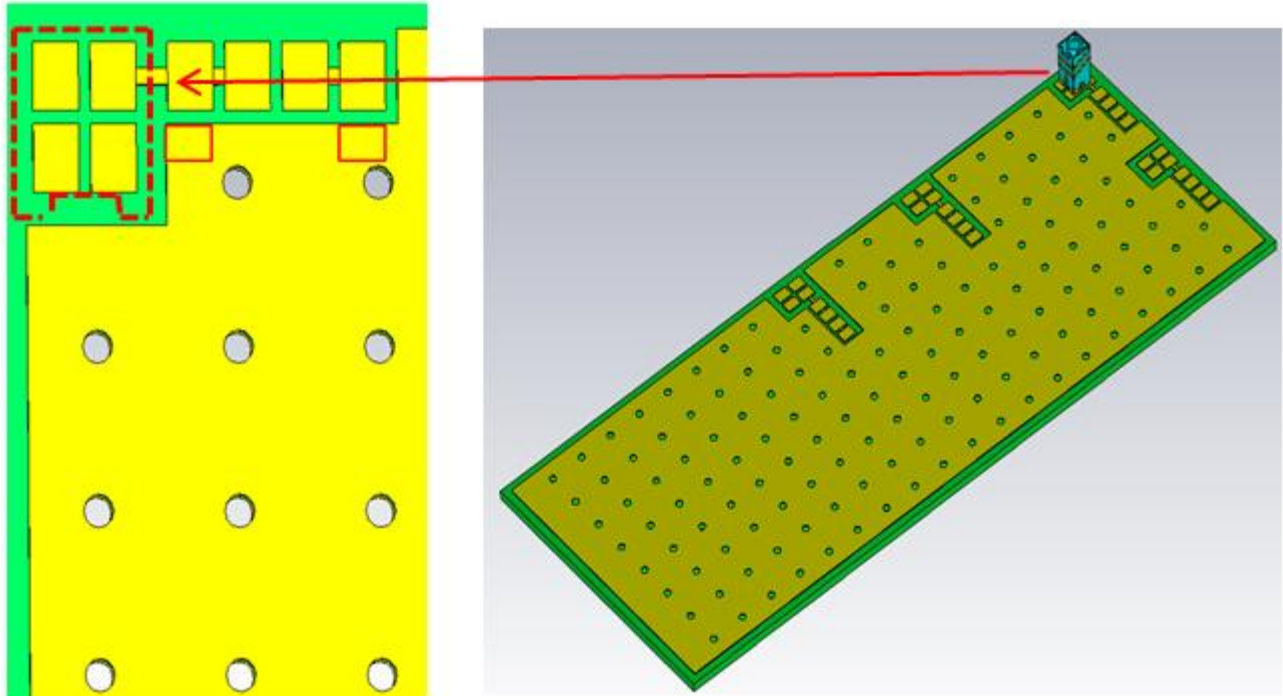

Figure 3

IV. MATCHING NETWORK DESCRIPTION

A matching circuit is needed if the resonance frequency needs adjustment due to loading by the device housing and surrounding components effect.

A series inductor and a shunt capacitor will shift the frequency downward about 50MHz. See figure 4.

REVISION: C	ECR/ECN INFORMATION: EC No: ABU2016-0022 DATE: 2015 / 8 / 28	TITLE: 2.4 GHz SMD On Ground Antenna Application Specification	SHEET No. 4 of 14
DOCUMENT NUMBER: AS-47948-001	CREATED / REVISED BY: Benson Liu	CHECKED BY: Ryan Liu	APPROVED BY: Welson Tan



APPLICATION SPECIFICATION

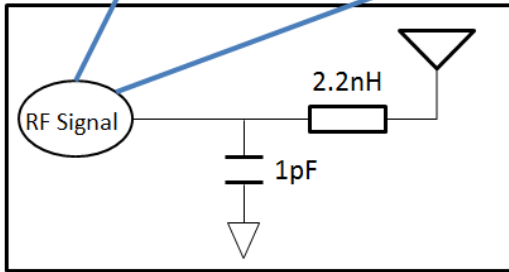
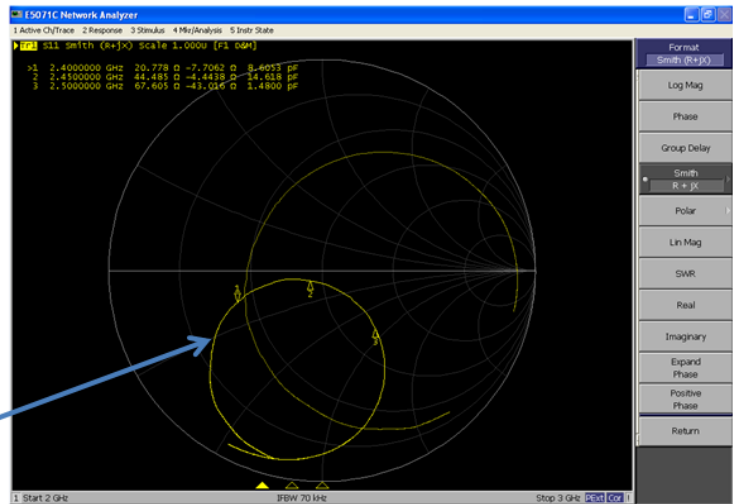
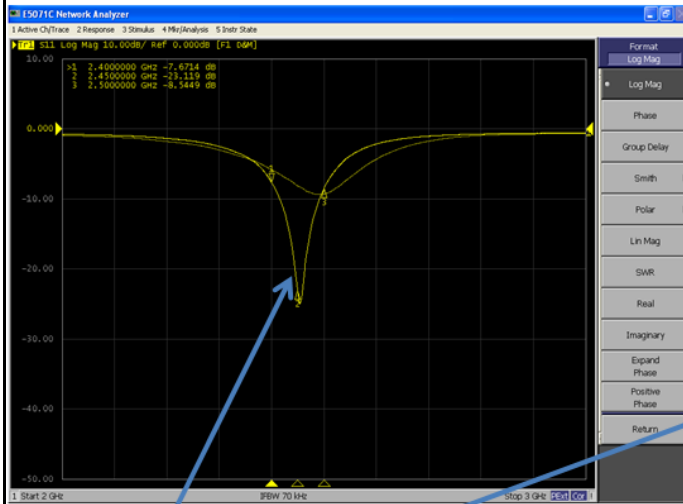

The above matching circuit topology will move the resonance frequency downward

From evaluation, about 50MHz can be shifted upward

Figure 4

REVISION: C	ECR/ECN INFORMATION: EC No: ABU2016-0022 DATE: 2015 / 8 / 28	TITLE: 2.4 GHz SMD On Ground Antenna Application Specification	SHEET No. 5 of 14
DOCUMENT NUMBER: AS-47948-001	CREATED / REVISED BY: Benson Liu	CHECKED BY: Ryan Liu	APPROVED BY: Welson Tan

V. RF PERFORMANCE AS A FUNCTION OF IMPLEMENTATION

1. ANTENNA RF PERFORMANCE AS A FUNCTION OF LOCATION ON THE PCB

4 locations have been evaluated, and these locations are show in figure 5(The matching is the same as Location 1). The location which gives the best RF performance is location 1. Location 1 (corner location) is the recommended location for the antenna.

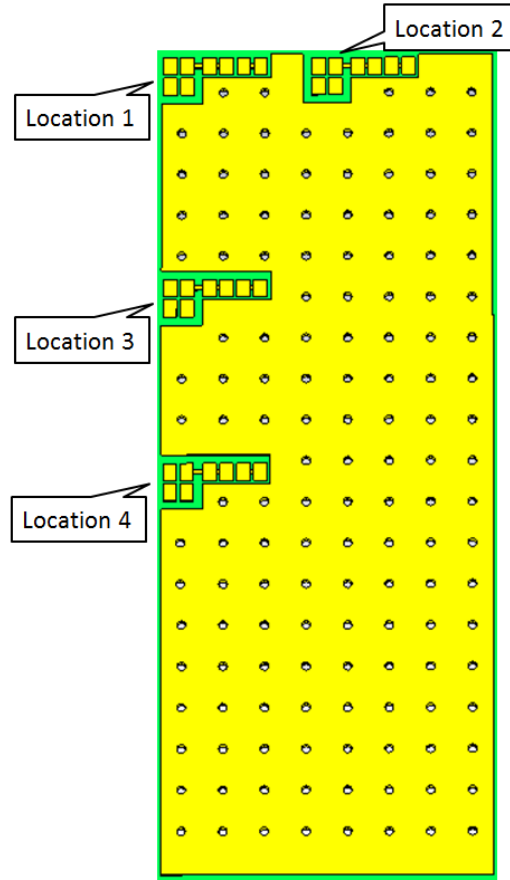

Figure 5

REVISION: C	ECR/ECN INFORMATION: EC No: ABU2016-0022 DATE: 2015 / 8 / 28	TITLE: 2.4 GHz SMD On Ground Antenna Application Specification	SHEET No. 6 of 14
DOCUMENT NUMBER: AS-47948-001	CREATED / REVISED BY: Benson Liu	CHECKED BY: Ryan Liu	APPROVED BY: Welson Tan



APPLICATION SPECIFICATION

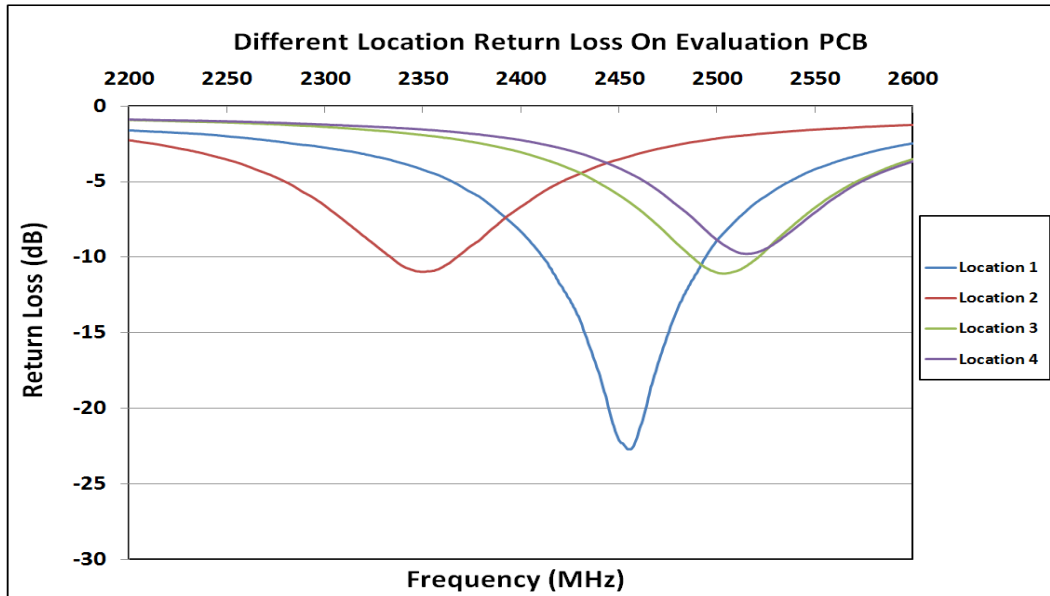

Figure 6: Return loss of comparison of different location on PCB

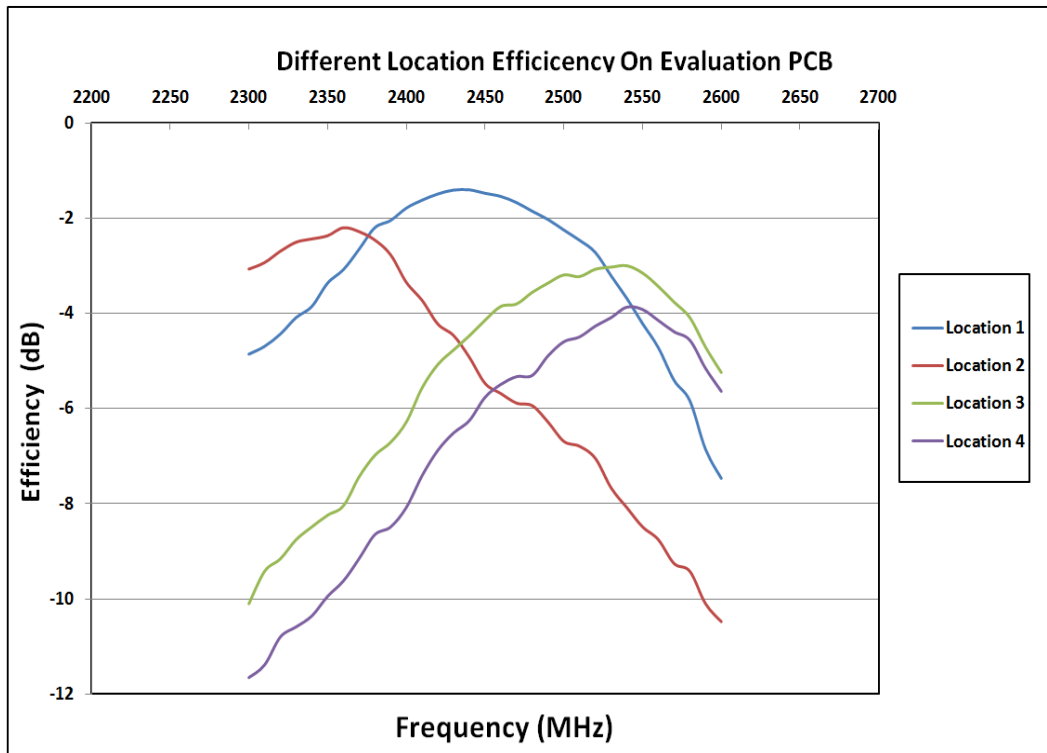

Figure 7: Total efficiency of comparison of different location on PCB

REVISION: C	ECR/ECN INFORMATION: EC No: ABU2016-0022 DATE: 2015 / 8 / 28	TITLE: 2.4 GHz SMD On Ground Antenna Application Specification	SHEET No. 7 of 14
DOCUMENT NUMBER: AS-47948-001	CREATED / REVISED BY: Benson Liu	CHECKED BY: Ryan Liu	APPROVED BY: Welson Tan

2. ANTENNA RF PERFORMANCE AS AN EFFECT OF NEARBY SHIELDING CAN

An evaluation was done with 3 different distances from the antenna which located at the recommended location. The 3 distances is as follow: 1mm, 3mm and 5mm.

From the study, we can say that the minimum distance a shielding can (30mm x 30mm x 2mm) should be placed from the antenna is 5mm. At distances less than 5mm the antenna performance will be significantly degraded. Refer to figure 8, 9 and 10.

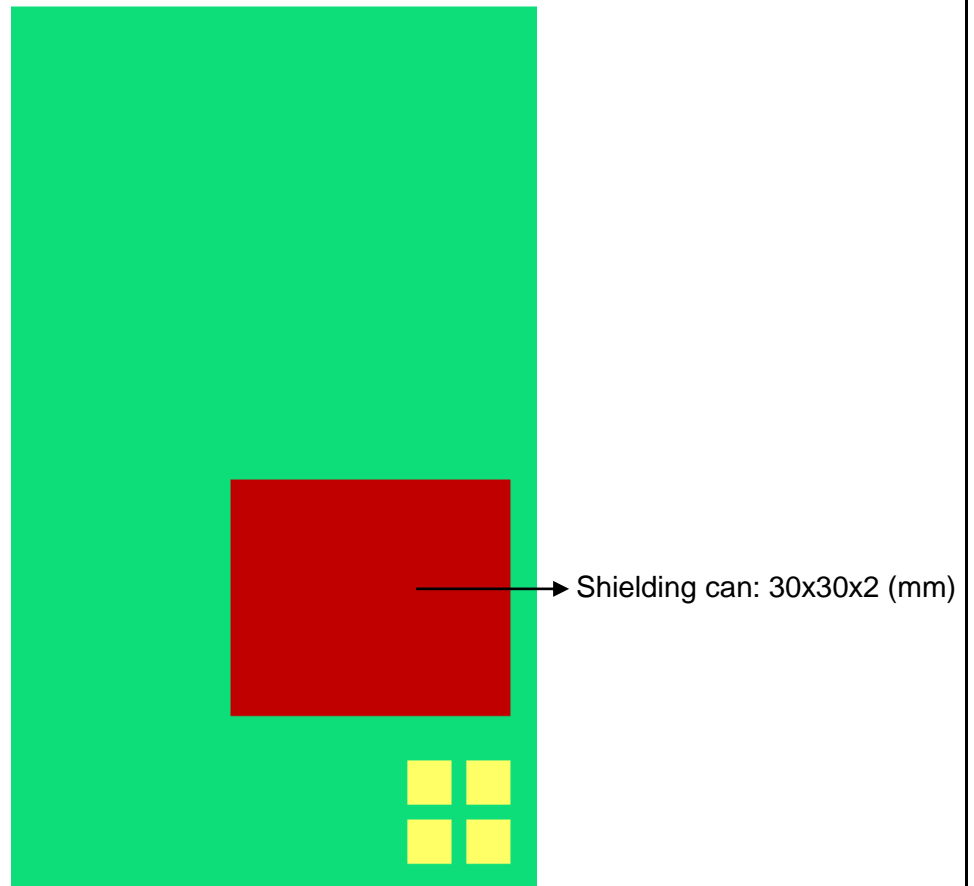

Figure 8

REVISION: C	ECR/ECN INFORMATION: EC No: ABU2016-0022 DATE: 2015 / 8 / 28	TITLE: 2.4 GHz SMD On Ground Antenna Application Specification	SHEET No. 8 of 14
DOCUMENT NUMBER: AS-47948-001	CREATED / REVISED BY: Benson Liu	CHECKED BY: Ryan Liu	APPROVED BY: Welson Tan



APPLICATION SPECIFICATION

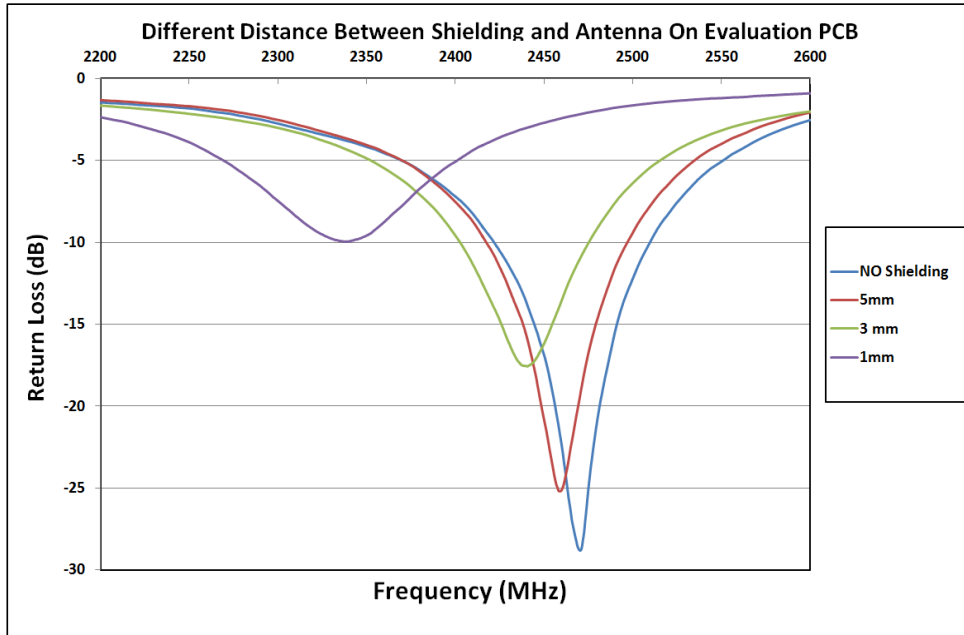

Figure 9: Return loss comparison of shielding can distance from antenna

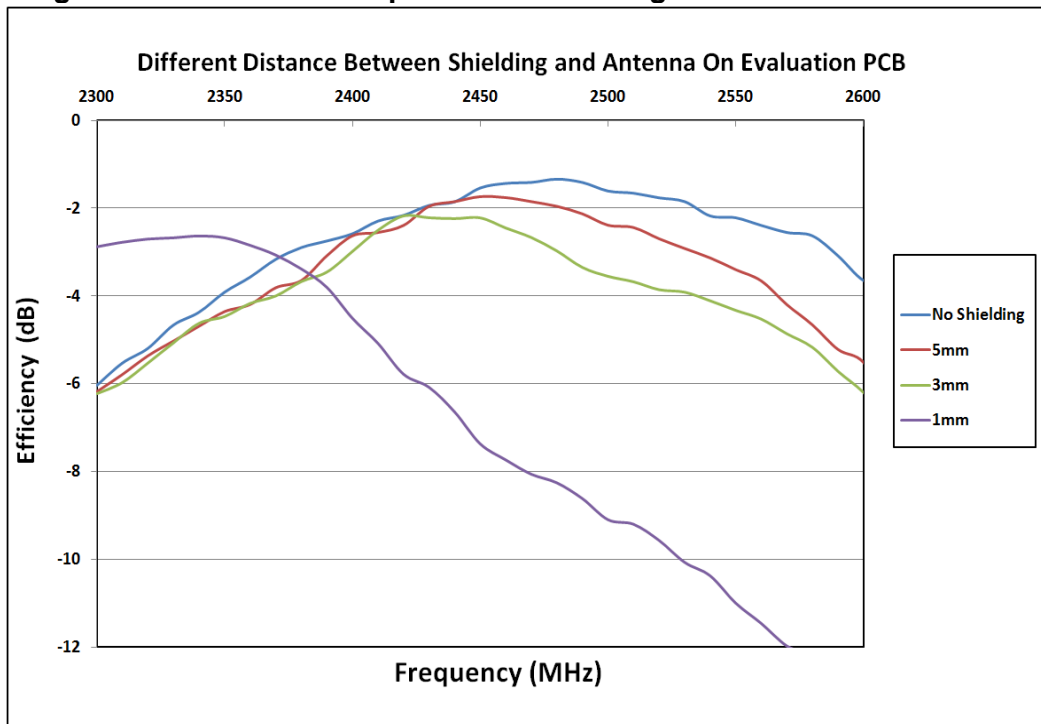

Figure 10: Total efficiency comparison of shielding can distance from antenna

REVISION: C	ECR/ECN INFORMATION: EC No: ABU2016-0022 DATE: 2015 / 8 / 28	TITLE: 2.4 GHz SMD On Ground Antenna Application Specification	SHEET No. 9 of 14
DOCUMENT NUMBER: AS-47948-001	CREATED / REVISED BY: Benson Liu	CHECKED BY: Ryan Liu	APPROVED BY: Welson Tan

3. RF PERFORMANCE AS AN EFFECT OF NEARBY BATTERY

An evaluation was done with 3 different distances from the antenna which located at the recommended location. The 3 distances is as follow: 1mm, 3mm and 5mm.

From the study, we can say that the minimum distance a battery (30mm x 60mm x 3mm) should be placed from the antenna is 5mm. At distances less than 5mm the antenna performance will be degraded significantly. Refer to figure 11, 12 and 13.

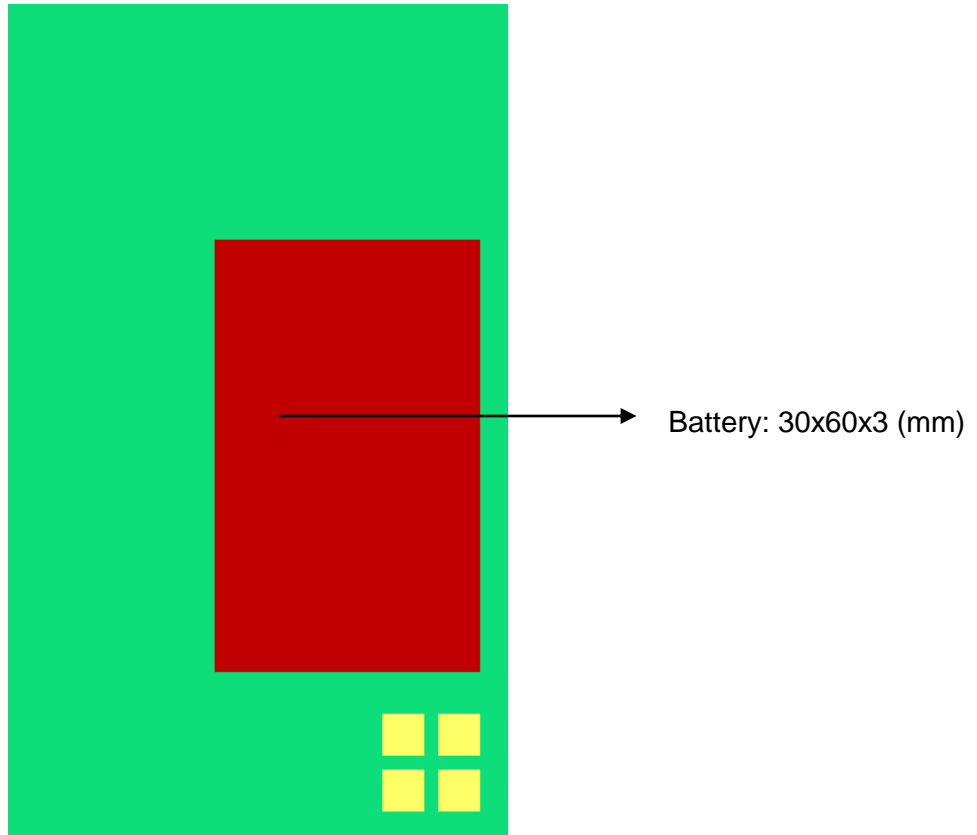

Figure 11

REVISION: C	ECR/ECN INFORMATION: EC No: ABU2016-0022 DATE: 2015 / 8 / 28	TITLE: 2.4 GHz SMD On Ground Antenna Application Specification	SHEET No. 10 of 14
DOCUMENT NUMBER: AS-47948-001	CREATED / REVISED BY: Benson Liu	CHECKED BY: Ryan Liu	APPROVED BY: Welson Tan



APPLICATION SPECIFICATION

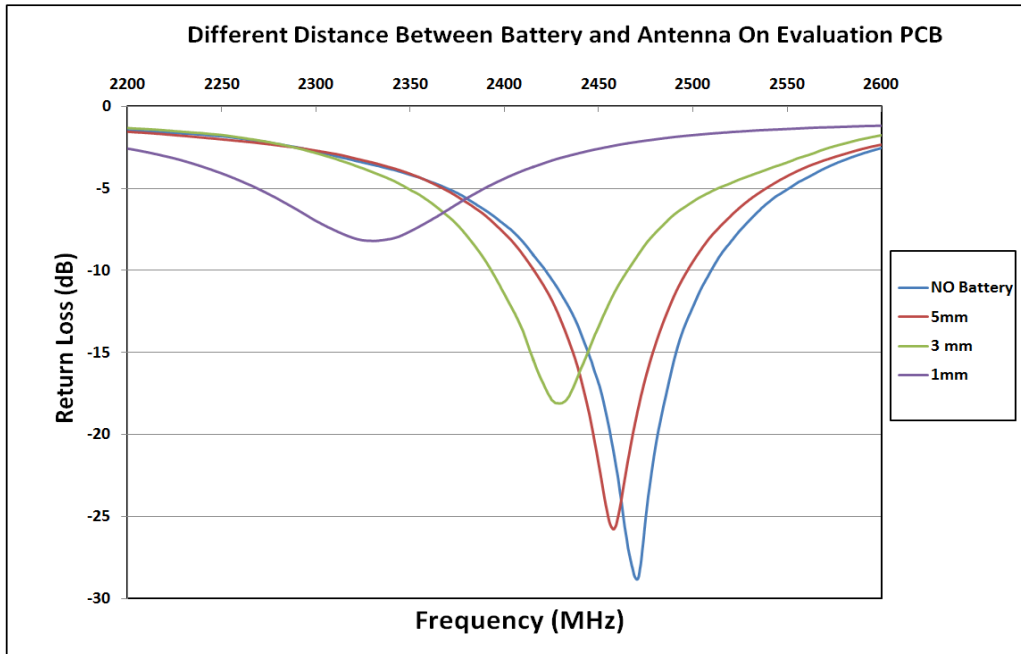

Figure 12: Return loss comparison of battery distance from antenna

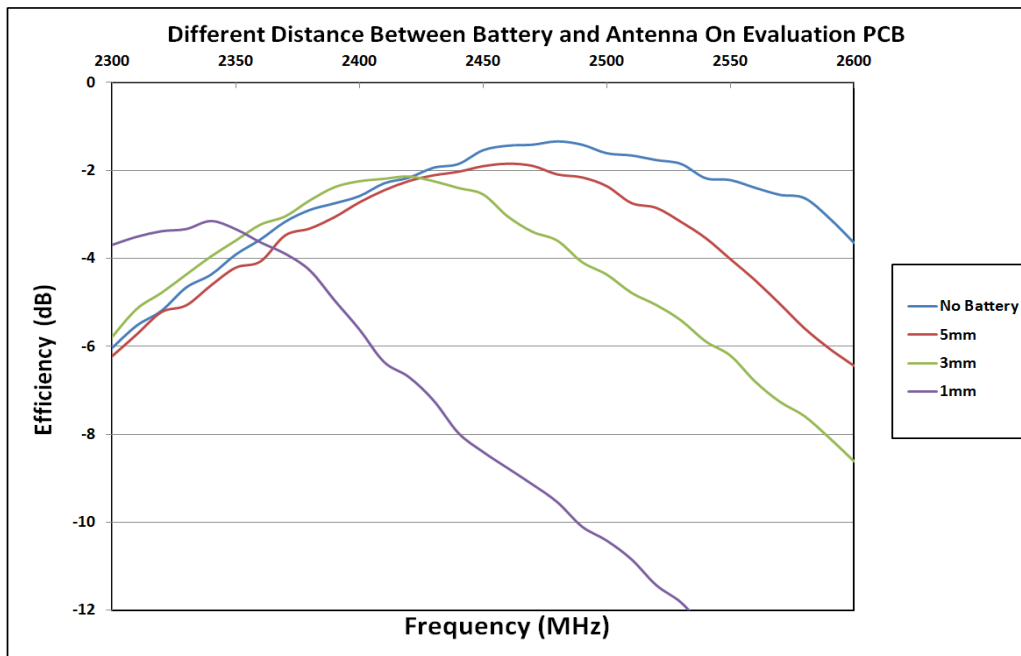

Figure 13: Total efficiency comparison of battery distance from antenna

REVISION: C	ECR/ECN INFORMATION: EC No: ABU2016-0022 DATE: 2015 / 8 / 28	TITLE: 2.4 GHz SMD On Ground Antenna Application Specification	SHEET No. 11 of 14
DOCUMENT NUMBER: AS-47948-001	CREATED / REVISED BY: Benson Liu	CHECKED BY: Ryan Liu	APPROVED BY: Welson Tan

4. RADIATION PATTERN

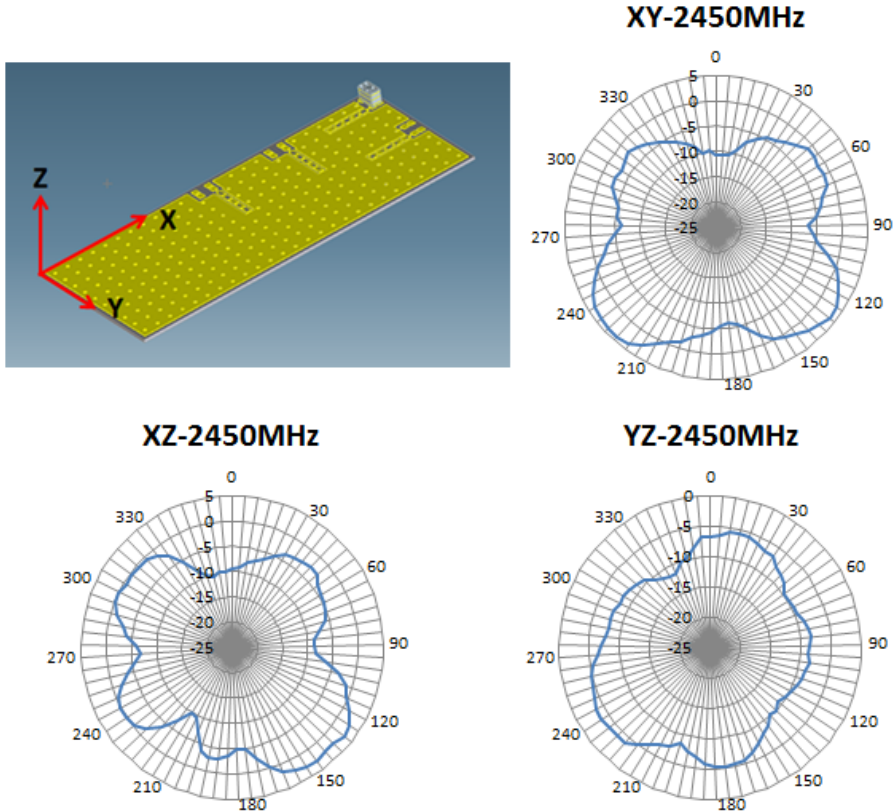

Figure 14: Radiation Pattern of antenna at 2.45GHz at Free space

REVISION: C	ECR/ECN INFORMATION: EC No: ABU2016-0022 DATE: 2015 / 8 / 28	TITLE: 2.4 GHz SMD On Ground Antenna Application Specification	SHEET No. 12 of 14
DOCUMENT NUMBER: AS-47948-001	CREATED / REVISED BY: Benson Liu	CHECKED BY: Ryan Liu	APPROVED BY: Welson Tan



APPLICATION SPECIFICATION

3.2 ASSEMBLY INSTRUCTIONS

A. RECOMMENDED SMT REFLOW PROFILE

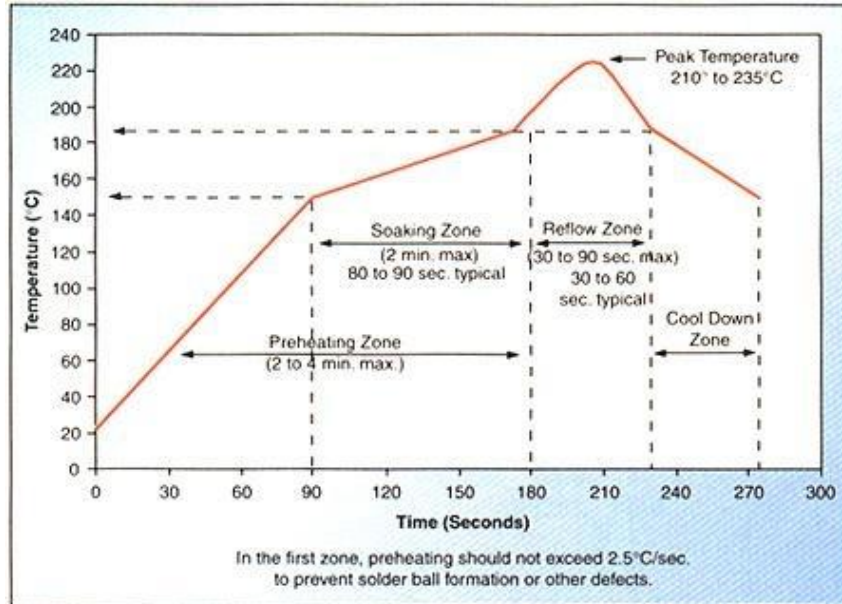

Figure 15

B. MECHANICAL INTERFACE

I. GENERAL DESCRIPTION

The overall antenna size is 3mm x 3mm x 4mm

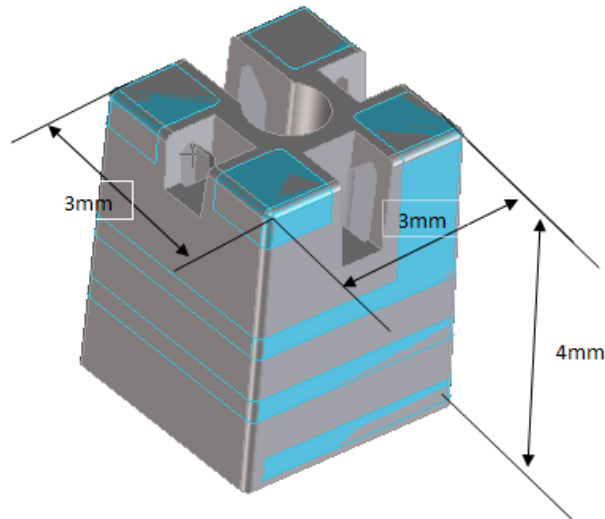

Figure 16

REVISION: C	ECR/ECN INFORMATION: EC No: ABU2016-0022 DATE: 2015 / 8 / 28	TITLE: 2.4 GHz SMD On Ground Antenna Application Specification	SHEET No. 13 of 14
DOCUMENT NUMBER: AS-47948-001	CREATED / REVISED BY: Benson Liu	CHECKED BY: Ryan Liu	APPROVED BY: Welson Tan

II. STRUCTURE FUNCTIONAL DESCRIPTION

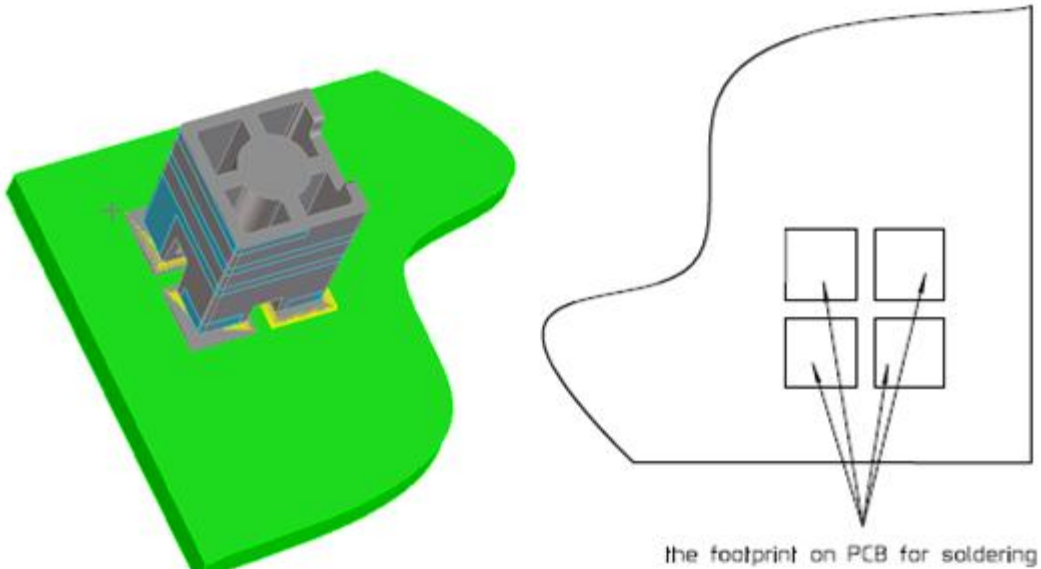

Figure 17

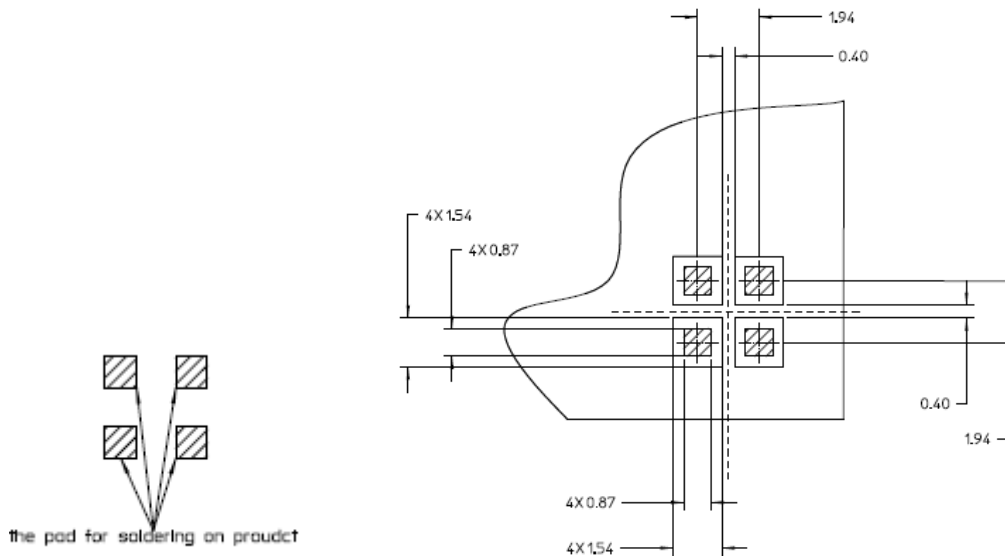

Figure 18: Footprint on PCB for soldering

REVISION: C	ECR/ECN INFORMATION: EC No: ABU2016-0022 DATE: 2015 / 8 / 28	TITLE: 2.4 GHz SMD On Ground Antenna Application Specification	SHEET No. 14 of 14
DOCUMENT NUMBER: AS-47948-001	CREATED / REVISED BY: Benson Liu	CHECKED BY: Ryan Liu	APPROVED BY: Welson Tan