

Cubii® **Go+**™

PORTABLE SEATED ELLIPTICAL

Owner's Manual

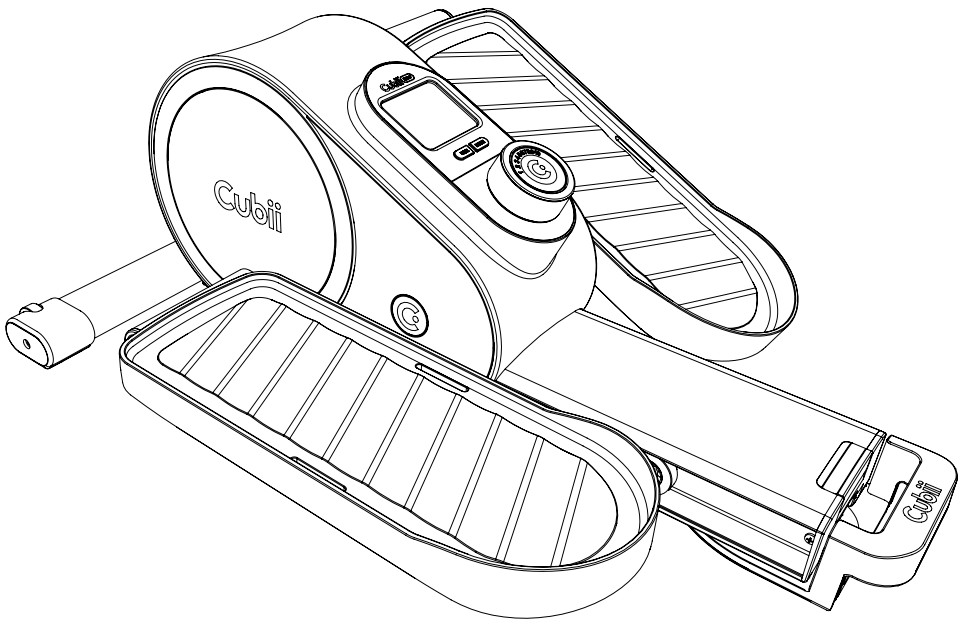

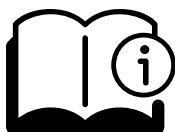
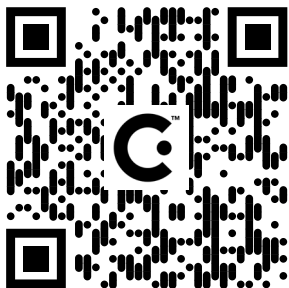

Additional product information can be found online

Weitere Produktinformationen finden Sie online

Puede encontrar información adicional sobre el producto en línea

Des informations supplémentaires sur les produits sont disponibles en ligne

Ulteriori informazioni sul prodotto sono disponibili online

Meer productinformatie vindt u online

manuals.cubii.com

TABLE OF CONTENTS

Before You Begin	2
Safety Instructions	
Consult Your Physician	
Getting Started	4
Product Size and Weight	
What's in the Box	
Warning Labels	
Serial Number Location	
Assembling Your Unit	6
Using Your Cubii Go+	10
Transporting	
Positioning	
Adjusting the Resistance	
Using the Chair Wheel Cup	
Charging Your Cubii Elliptical	
Battery Life and Power	
Reading the Display Console	
Connecting with Devices	
Installing and Pairing with the Cubii App	
Offline Mode	
BLUETOOTH® WIRELESS TECHNOLOGY Related App Features	
General Information	21
Return Policy and Warranty	
Troubleshooting	
Care and Maintenance	
Important Health & Safety Instructions	
Sensors and Motors	
Regulatory Notices	

Welcome to the Cubii Communitii™!

Whether you are taking the first step on your fitness journey or looking to get more exercise from the comfort of home, bringing the Cubii Go+ into your routine is a big stride toward a healthier, more active life! Before you begin, we want you to be familiar with important information on how to use Cubii Go+ safely so that you and your loved ones get the most out of your experience.

Let's review the safety notes and warnings now.

If you have any questions, please contact:

+1-844-282-4401

support@mycubii.com

cubii.com/help

BEFORE YOU BEGIN

Safety Warnings & Instructions

WARNING Consult your physician before starting this or any exercise program. This is especially important if you have never exercised before, are pregnant, or suffer from any health problem. If at any time during exercise, you feel faint, dizzy, or experience pain, stop and consult your physician.

WARNING Do not use when standing. Only use when sitting. Failure to follow all warnings and instructions could result in serious injury or death.

WARNING To reduce the risk of serious injury, read the following Safety Instructions before using Cubii Go+.

WARNING Wear sturdy, closed-toed shoes when using any Cubii elliptical.

Read all warnings and cautions posted on the Cubii Go+ unit.

1. Cubii Go+ should only be used after a thorough review of the Owner's Manual.
2. We recommend that two people are available for the unboxing of this product.
3. Set up and operate Cubii Go+ on a solid, level surface. Do not position Cubii Go+ on loose rugs or uneven surfaces.
4. Make sure that adequate space is available for access to and around Cubii Go+.
5. Before using, inspect Cubii Go+ for worn or loose components, and securely tighten or replace any worn or loose components prior to use.
6. Follow your physician's recommendations in developing your own personal fitness program.
7. Always choose a workout plan which best fits your fitness and ability level. Know your limits and train within them. Always use common sense when exercising.
8. Do not wear loose or dangling clothing while using Cubii Go+.

9. Be careful to maintain your balance on your chair while using, mounting, dismounting, or assembling Cubii Go+; loss of balance may result in a fall and serious bodily injury.
10. Keep both feet firmly and securely on the pedals while exercising.
11. Maximum recommended user weight is 300 pounds (136 kg).
12. Cubii Go+ should be used by only one person at a time.

USE ONLY WHILE SITTING, DO NOT STAND ON THE UNIT UNDER ANY CIRCUMSTANCE.

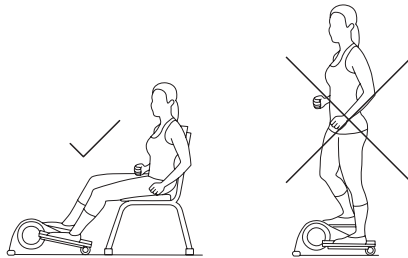

Consult Your Physician

It is always important to consult your physician before starting an exercise program. This is particularly true if any of the following apply to your current medical condition:

- Chest pain or pain in the neck and/or arm
- Shortness of breath
- A diagnosed heart condition
- Joint and/or bone problems
- Currently taking cardiac and/or blood pressure medications
- Have not previously been physically active
- Dizziness or blurred vision
- Those with physical handicaps

If you feel any of the physical symptoms listed above when you start your exercise program, contact your physician right away.

GETTING STARTED

Product Size and Weight

The assembled Cubii Go+ measures:
24.8"L x 17.3"W x 8.9"H (63cm x 44cm x 22.7cm)

The weight of the unit is approximately 20.5lb (9.3kg).

What's in the Box

Go+ Main Body
Left Pedal
Right Pedal
Cross Member

Charging Cable
AC Power Adapter
M5 Allen Wrench

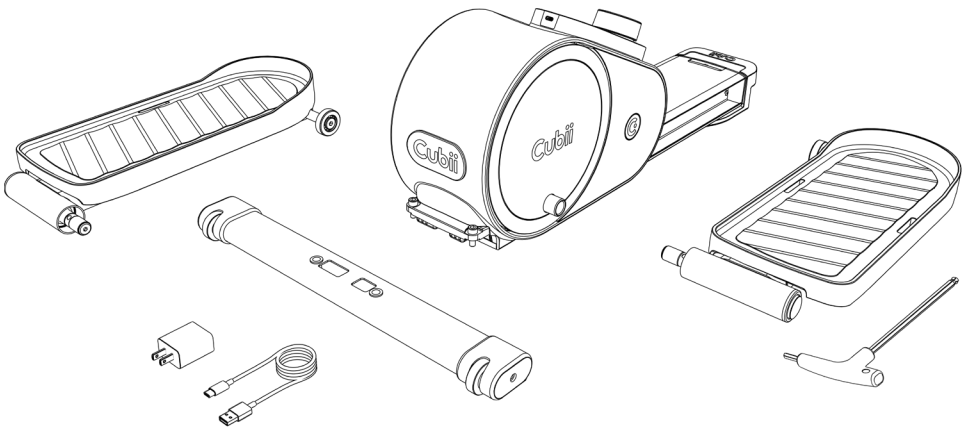

Warning Labels

The warning label is located on your Cubii Go+ product here:

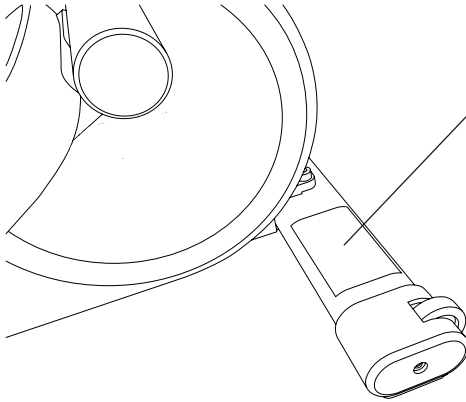

WARNING
Failure to follow all warnings and instructions could result in serious injury or death. Before assembling or using this product, read and follow the Owner's Manual and all other instructions that accompany this product. Replace this warning label if damaged, illegible, or removed.
Keep others including children and pets away from equipment.
Consult your physician before starting this or any exercise program. This is especially important if you are over the age of 35 or have any preexisting health condition. Always make sure all nuts and bolts are securely tightened before using this product. The maximum weight that can be applied is 300 lb or 136 kg.
DO NOT USE WHILE STANDING. USE ONLY WHEN SITTING. STANDING ON THE UNIT MAY CAUSE SERIOUS INJURY.

Serial Number Location

The serial number is located on your Cubii Go+ product here:

Product Label

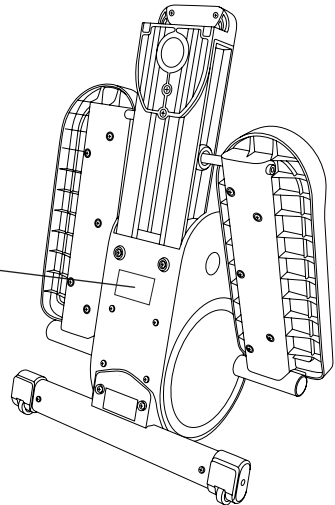
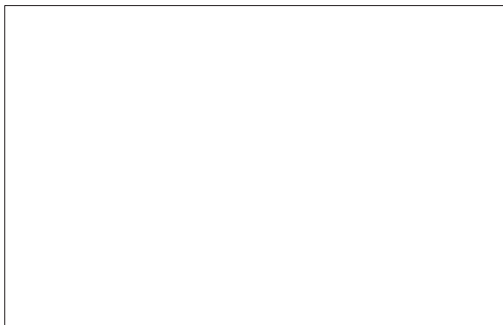

Record your serial number here
for future reference:



Assembling Your Unit

Follow the steps below to assemble your Cubii Go+ Portable Seated Elliptical.

Step 1 – Crossbar

Before installing the crossbar, orient the roller wheels to point away from the body of the unit, and with the screw holes facing up. Lower the unit onto the crossbar so that the holes line up with the screws. Tighten screws with the included wrench, taking care not to scratch your Cubii Go+.

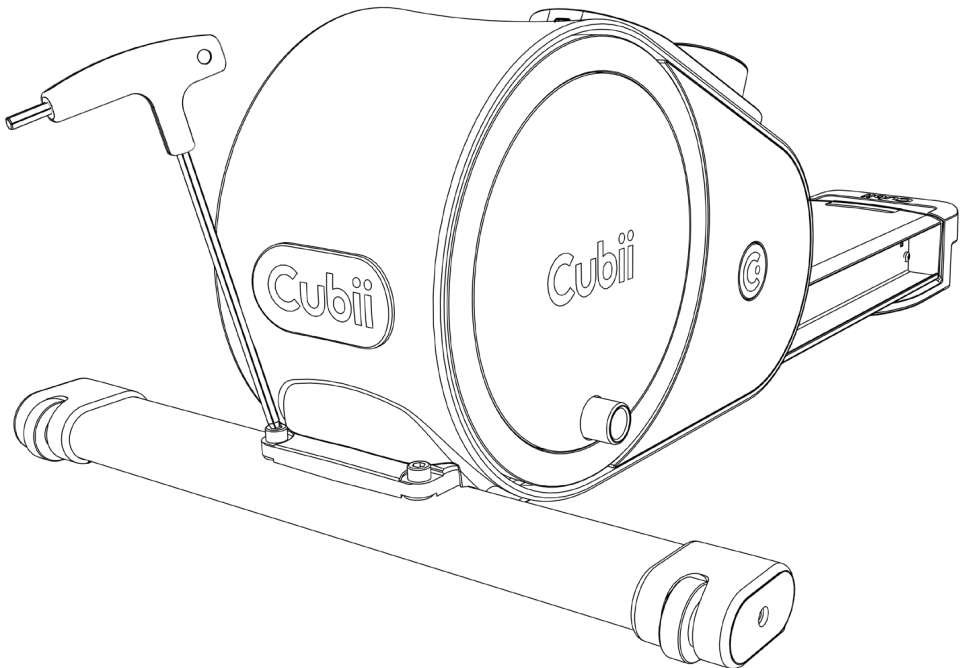
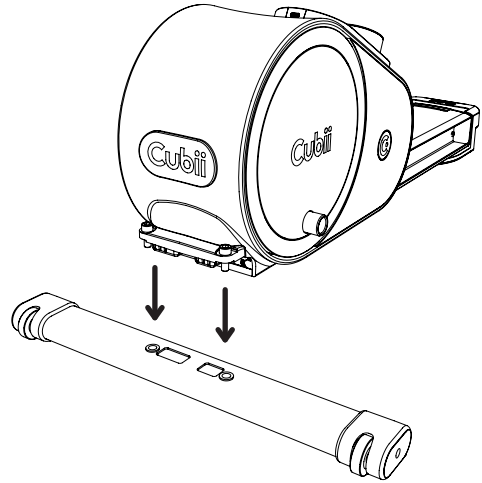

Step 2 – Align Pedal

Align the right pedal tube with the tube shaft on the ring of the elliptical. Insert the pedal tube into the tube shaft and push in until the unit stops.

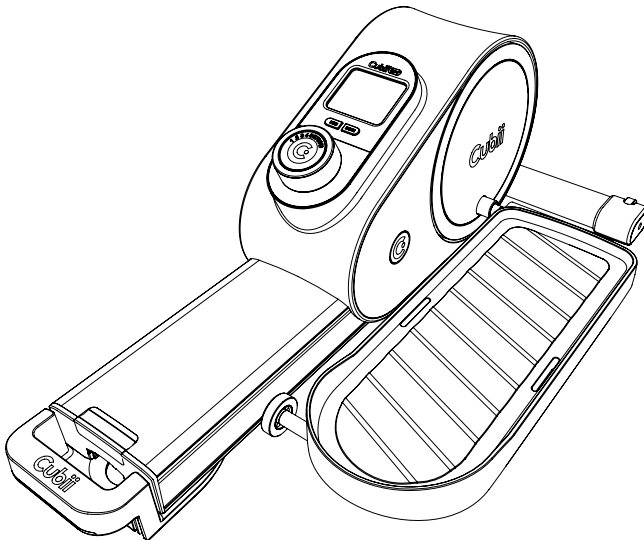
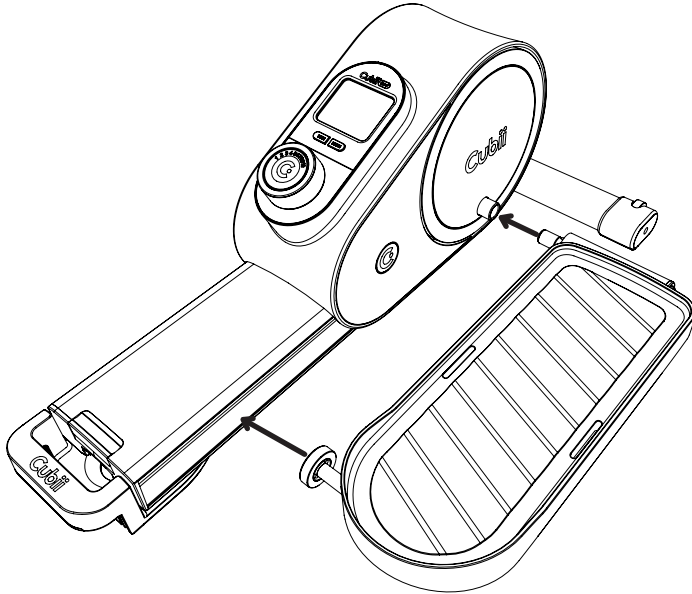

III. Assembling Your Unit

Step 3 – Press and Insert Pedals

Align the pedal wheel with the wheel track on the bottom side of the elliptical. Once aligned, push the button on the pedal tube and continue pushing in the pedal into the tube shaft.

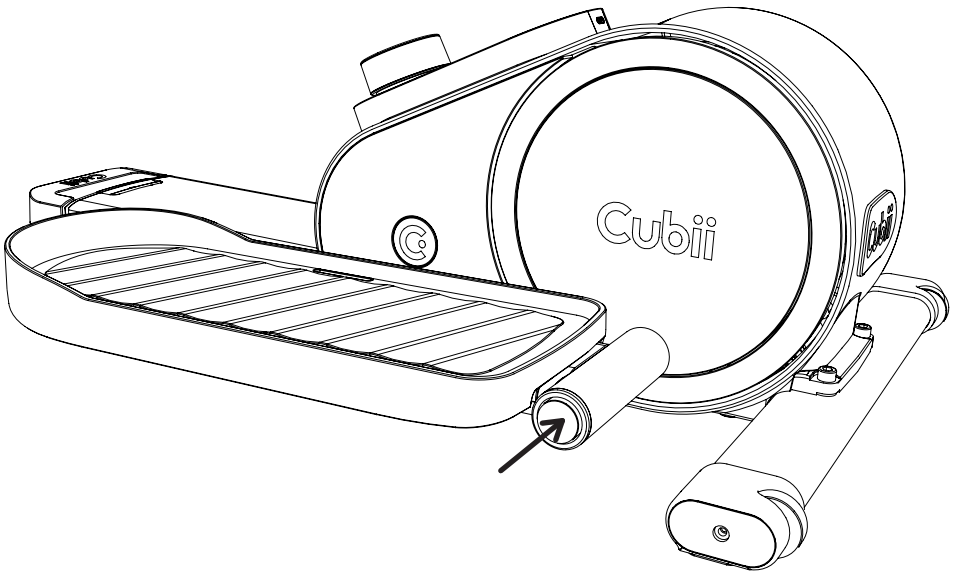
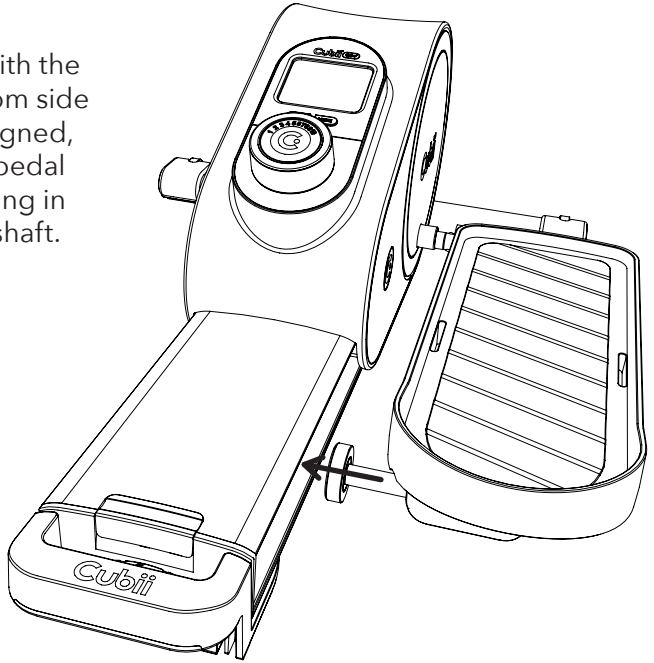

Step 4 – Click and Lock

Continue pushing in the pedal into the tube shaft and wheel track until you hear a click or the pedal is pushed in all the way. To ensure your pedal is locked into place, release the button once the pedal is pushed in all the way and try to pull the pedal outwards. Your pedal should be locked into place.

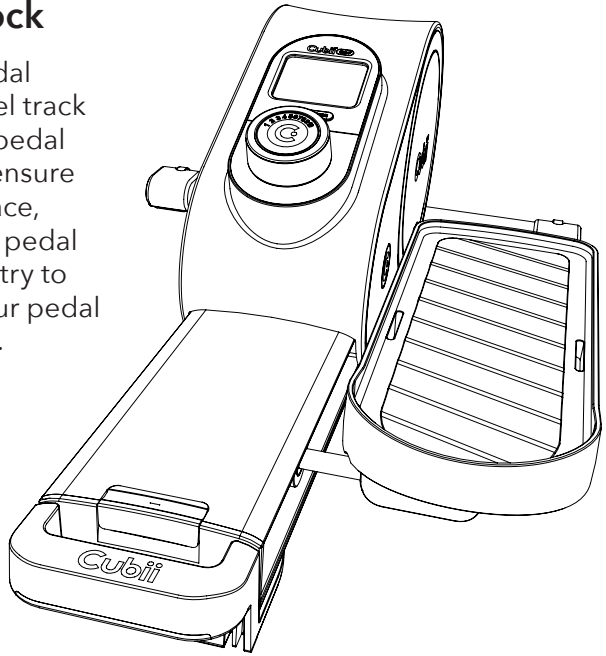

Step 5 – Repeat

Repeat steps 2-4 with the left pedal, then get moving!

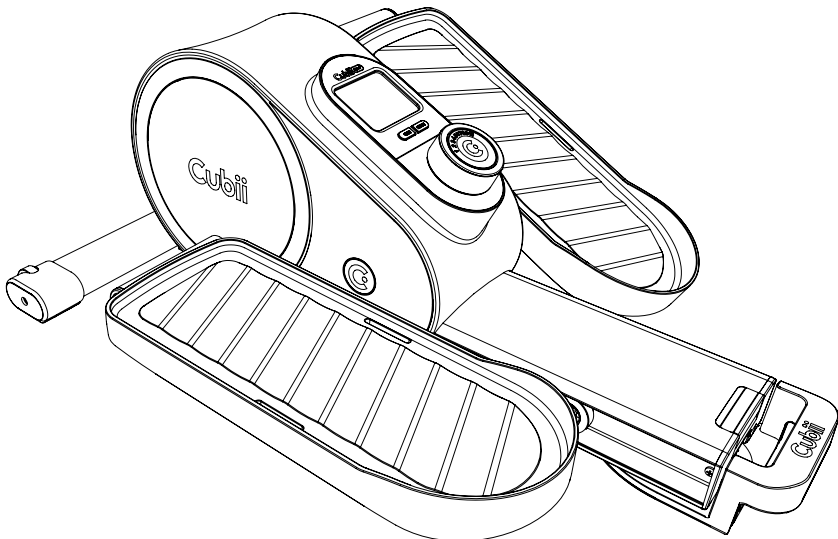

USING YOUR CUBII GO+

Make sure to have followed all of the assembly steps in the Quick Start guide before you begin using Cubii Go+.

Transporting

The Cubii Go+ features an extendable handle and roller wheels which allow the unit to be rolled across the floor, much like a rolling suitcase. To do this, follow these steps:

1. Extend the handle by holding down the handle release button, then pull the handle out fully, about 8" (20cm).
2. Lift the handle to angle the unit and roll it to the desired position.
3. To collapse the handle, press the handle release button and slowly return the handle to the desired position. (Once you have started collapsing the handle, you can stop pressing the button.)
4. Lower Cubii Go+ to the ground in the desired position.

The unit can also be stood on end and lifted up to carry like a briefcase.

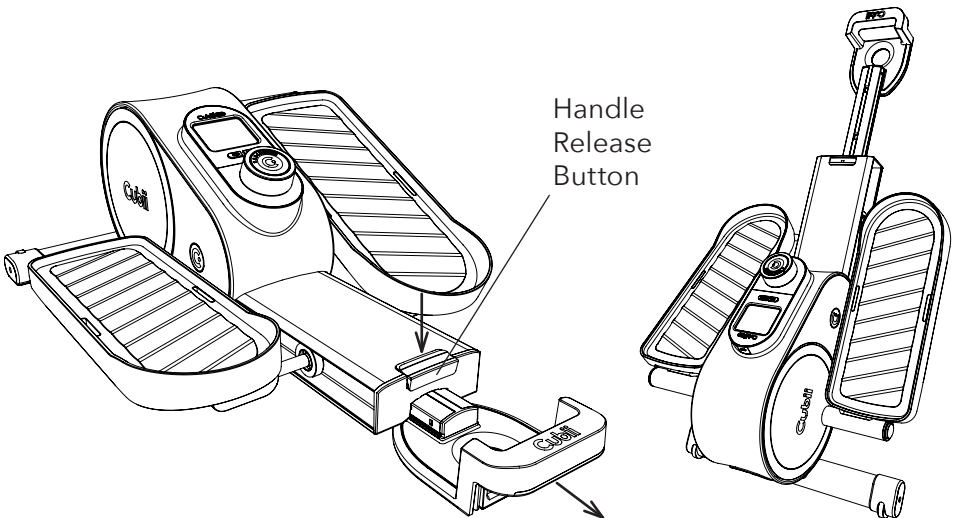

Positioning

The Cubii Go+ can be used either in an upright position, such as with an office chair, or in a more reclined position, such as when placed in front of a sofa.

- Cubii Go+ occupies a floor area of 24.8" x 17.3" (63cm x 44cm). Please leave a clear zone behind the training area that is at least 24" (0.6m). This zone must be clear of any obstruction and provide the user a clear exit path.
- Find the seat configuration that suits you most. If you feel there is not enough room between your knees and the desk, push your Cubii Go+ away from you and lower the chair height. Keep your back straight, and do not slouch.
- If you are sitting on an office chair with wheels, use the wheel cup.

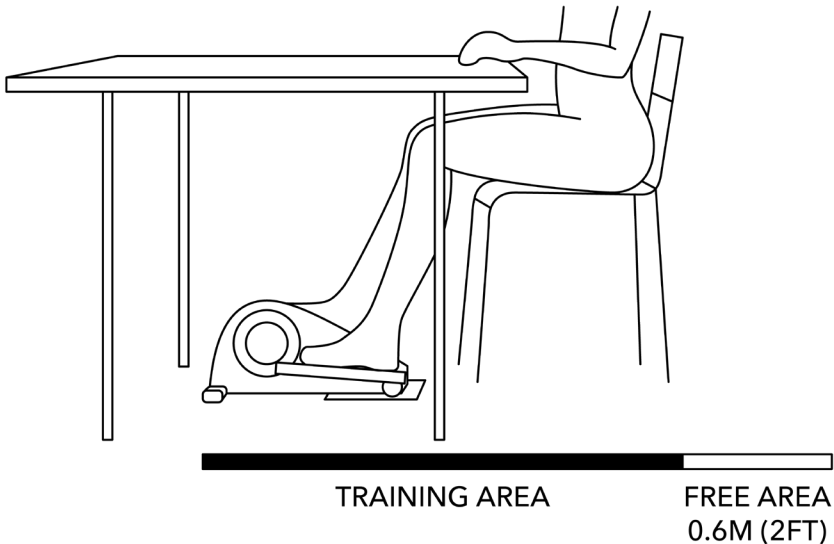

IV. Using Your Cubii Go+

Adjusting the Resistance

Cubii Go+ has 10 resistance levels. Adjust your workout intensity by turning the resistance control knob. Level 1 is the lowest intensity and level 10 is the highest. We recommend you begin at Level 1 and increase the intensity gradually over time.

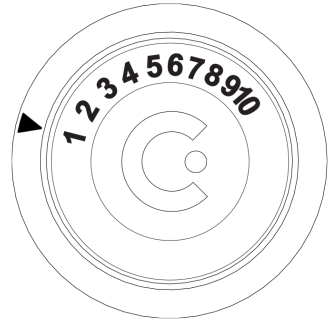

Using the Chair Wheel Cup

If you're using Cubii Go+ while sitting in a chair with wheels or castors, follow the steps below:

Extend the handle by at least 1 position to expose the wheel cup. To do this, press and hold down the Handle Release Button while pulling out the handle, about 2.2" (56mm). If you wish to use the Go+ in a more reclined position, you may extend the handle to the 2nd stop. Roll the wheel from your chair into the wheel cup.

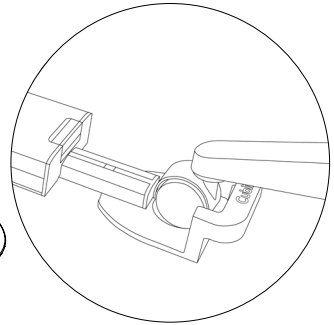
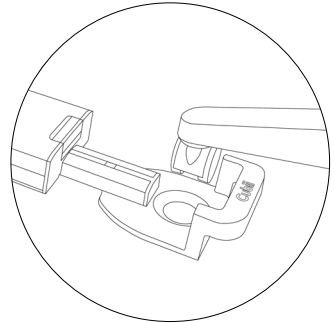
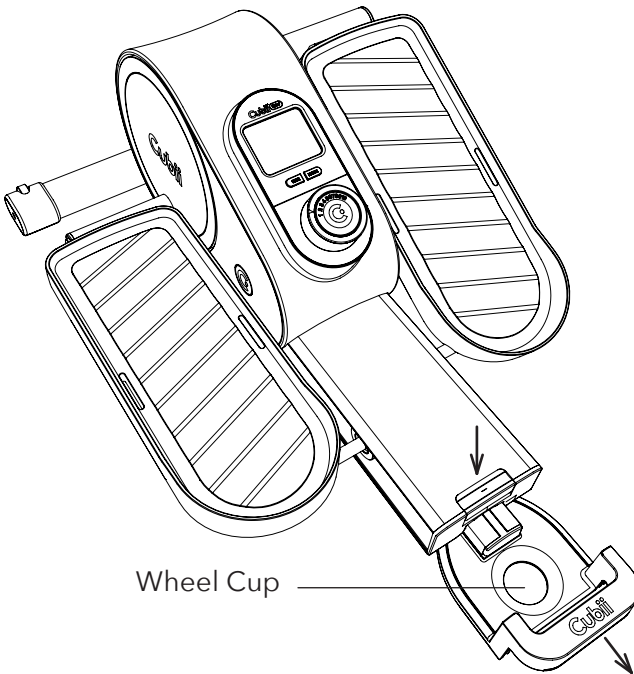

CHARGING YOUR CUBII ELLIPTICAL

Step 1 – Connect Wall Adapter

Connect charging cable to wall adapter and ensure wall adapter is plugged into power source.

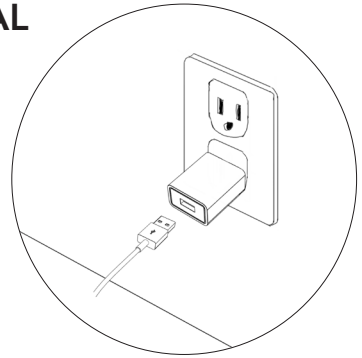

Step 2 – Locate Charging Socket

Locate the charging port on your Cubii elliptical and plug in the cable.

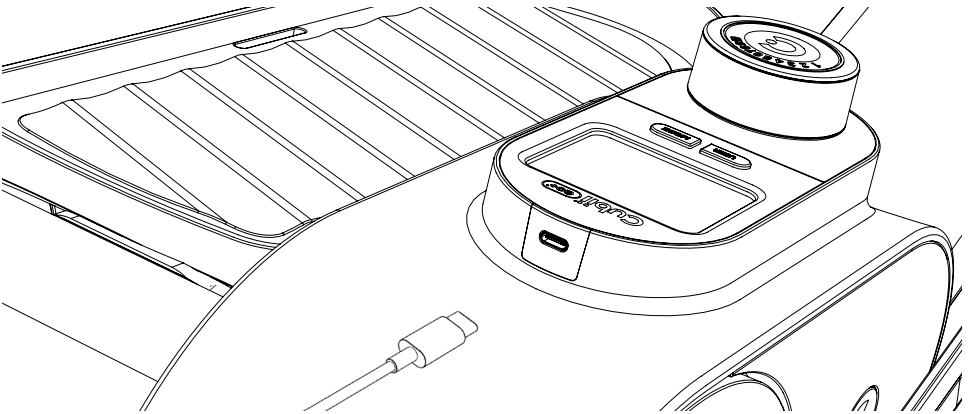

Step 3 – Check Display for Charging Symbol

Ensure charging cable is plugged in to your Cubii elliptical and cable is secure. Screen should be powered and lightning bolt symbol flashing to designate charge in progress. The lightning bolt symbol will remain solid when it is fully charged.

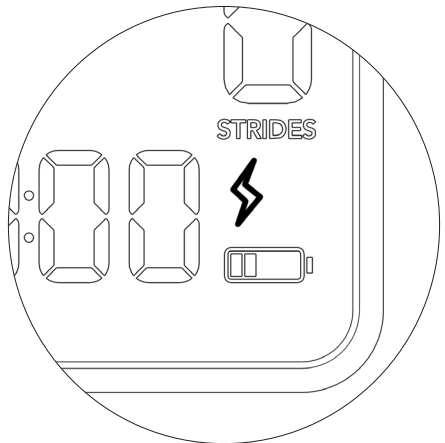

Battery Life and Power

The screen on your Go+ comes equipped with a rechargeable lithium-ion battery. With normal use, your Cubii elliptical should last about 30 days before you need to charge again. Charging your Go+ completely can take up to 6 hours. You can check the battery level in the Cubii app or on the built-in screen.

READING THE DISPLAY CONSOLE

User Options

Your Cubii Go+ elliptical can store data separately for User 1, User 2, and Guest. Press the User button to switch Users. The triangle indicates the selected User. You can also track each User's progress through the Cubii app.

Top Row

The top row displays your total number of strides. A "stride" is the equivalent of one full rotation of the pedaling motion.

Bottom Row

The bottom row displays the following metrics:

- Time (00:00:00-99:59:59 hour:min:sec) elapsed during active workout
- Distance (000.00-999.99 mi or km) pedaled during a workout
- Calories (000.00-999.99 kcal) during a workout
- RPM - (0-999 strides/min) rotations per minute during a workout

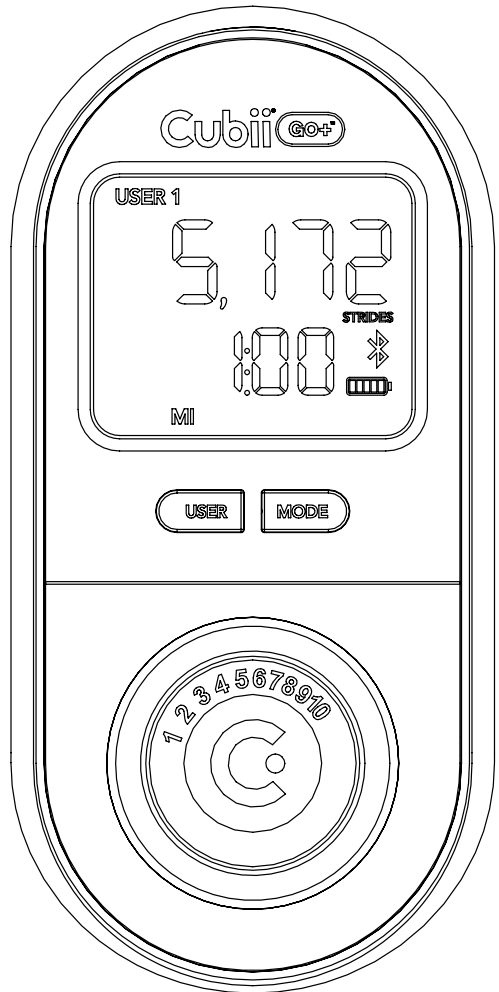

Press the MODE button to switch which metric is displayed. You can use the SCAN mode to automatically toggle between the above metrics every 7 seconds. The triangle indicator shows which view is selected.

BLUETOOTH® Wireless Technology Indicator

The Bluetooth® symbol will flash when your Go+ is available to connect to your mobile device or tablet. The Bluetooth® symbol will remain solid once your elliptical is connected to the Cubii mobile app. Your elliptical must be charged in order to pair with another device.

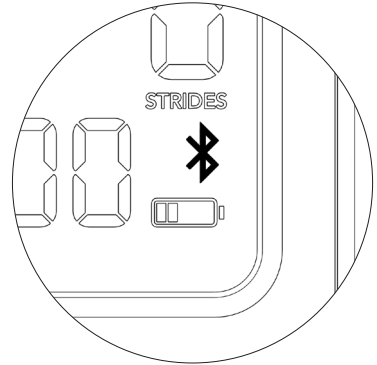

Battery Indicator

The number of bars in the battery symbol indicates the charge left in the battery. When the battery symbol reaches 0 bars, it will flash for 20 seconds, indicating that it requires charging. The battery symbol will flash during charging when battery level is below 100%. It will remain solid when charging is complete, but still plugged in. The symbol will disappear when your elliptical is not charging.

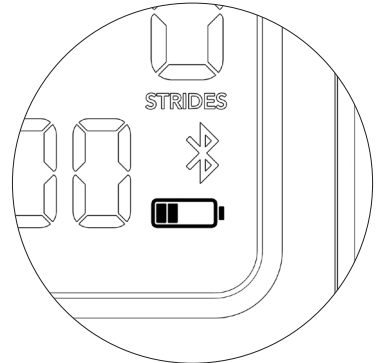

"Smart Reset"

All metrics are additive and counted throughout the day. Once you have paired the mobile app with your Cubii, then the metrics displayed on the console will automatically reset each evening at midnight (as long as your Cubii battery does not deplete). If you have not paired the mobile app with your Cubii, then the data will continue to aggregate unless you manually reset the data or manually setup the "smart reset" feature (see section below entitled *Manually Set a "Smart Reset"*).

*The Bluetooth® word mark and logos are registered trademarks owned by Bluetooth SIG, Inc. and any use of such marks by Fitness Cubed Inc is under license. Other trademarks and trade names are those of their respective owners.

Console Profile Reset

User 1 and User 2 profiles can be reset from the console. Simply select the relevant user profile then hold the User button for 3 seconds then release the button to complete the profile reset. Resetting the user profile from the built-in console erases any data stored for that profile and also delinks the profile from the app. The profile can be easily re-established in the app if needed.

Manual Data Reset

Manually reset data for any profile on the console (User 1, User 2 or Guest) by selecting the relevant profile (see User Button section above) and then holding the Mode button for 3 seconds then release the button to complete the profile reset. This action resets any data displayed on the screen for the selected profile.

Distance Metric Toggle

To switch from miles to kilometers (or kilometers to miles), use the MODE button to select the Distance metric. Then, hold the MODE button for 6 seconds. If you are using the Cubii app, this update will also be reflected there.

Manually Set a "Smart Reset"

If you do not pair your elliptical to the Cubii app, but still want your console to reset each evening at midnight, follow the instructions below to set the clock to the current time:

1. Simultaneously press the USER and MODE buttons 3 times in a row to reset the clock. It should flash "00:00".
2. Press the USER button to cycle through hours until you get to the right hour. Note that the clock uses military time.
3. Press the MODE button to cycle through minutes until you get to the right minute.
4. Once you have entered the current time, simultaneously press the USER and MODE buttons 3 times in a row to save the time.

If there is no activity for more than 5 seconds during this process, the reset will be cancelled.

The “smart reset” feature is **ONLY** activated if the user performs the manual actions above to set the RTC on the console (or it will automatically be applied if the user connects their app). If you do not choose to manually set the clock following the instructions above, and do not connect to the Cubii app, your console will continue to add and display all data until you manually reset the screen.

Please note the “smart reset” function and clock setting will only remain while the battery retains enough capacity to power the device. If the battery is depleted, the “smart reset” feature must again be manually established using the above instructions.

Connecting with Devices

Your Cubii Go+ is a connected Bluetooth® Low Energy device, meaning it can pair directly with the Cubii mobile app to automatically track your workouts. The app also supports many other features such as viewing your workout history, setting goals and tracking against them, creating or participating in group leaderboards, chatting with friends and much more.

Supported Devices

Your Go+ can sync with select mobile devices that support Bluetooth® 4.0 technology. Currently, we support iPhone mobile devices running iOS® 12.0 or higher. (Note that supported versions are subject to change over time. After you’ve created an account, Cubii will inform you if/when your device requires an update).

Installing the Cubii App

To download the app for a device, search for “Cubii” in your app store. Click “Install”/ “Get”. Once it’s finished installing, click “Open.” Once you open the app, you will be prompted to create an account. If you already have the Cubii app installed, check for available updates to make sure you have the latest version.

Pairing your Cubii Elliptical with the Cubii App

In order to pair with the Cubii app, please follow these instructions:

1. Start pedaling to trigger the Bluetooth® signal. You'll see the Bluetooth® symbol glow and start blinking.
2. Confirm that you've enable Bluetooth® Wireless Technology in your device's settings.
3. Upon opening the Cubii app for the first time, you will be prompted to create an account. Be sure to review/accept the Terms of Use and Privacy Policy.
4. Complete your profile and follow the other in-app instructions.
5. The app will detect your Cubii elliptical via Bluetooth® Wireless Technology. Select your elliptical in the app.
6. Once successfully paired, the Bluetooth® symbol on your built-in screen will stop blinking.
7. The app will ask if you would like to become User 1, User 2, or proceed as Guest. Make a selection.
8. Start your workout and enjoy your Cubii experience!
9. From here on, every time you launch the app, it will search for all Cubii devices in your vicinity and automatically connect with an elliptical that it has already paired with. If it does not automatically reconnect, you can manually search and connect it in the app.

In order to pair with a new Cubii elliptical in the same vicinity, you must first disconnect from the previous Cubii elliptical. This can be done in the app. Your elliptical can also only pair to one app user at a time. To allow another user to connect their app to the elliptical, you must first disconnect.

Offline Mode

The Cubii app should remain open in the background in order for Cubii to send data to your device. If the app is not open, then the Cubii itself will store your workout data until the next time your app is paired, at which point the data will be retrieved. The exercise stats will be attributed to the date/time they occurred.

iOS is a registered trademark of Cisco Systems, Inc. and/or its affiliates in the United States and certain other countries.

BLUETOOTH® RELATED APP FEATURES

In addition to the automated tracking and storing of your workout data, the mobile app also offers a few other features specifically related to the Bluetooth® connectivity. Each of the capabilities listed below are available when your elliptical is actively paired with the app.

Distance Metric Toggle

Switch from miles to kilometers, or kilometers to miles, by switching the setting in the mobile app. When this action is taken, the app communicates the change to the elliptical console so it displays the appropriate distance metric.

Resistance Level

The Cubii app will automatically retrieve the resistance level from the elliptical. However, please note that the app CANNOT update the resistance on the elliptical itself. The resistance is managed by the elliptical and the app reads that information.

User 1, User 2 and Guest Profiles

Your Cubii elliptical offers multiple user profiles on the console in the event that you plan on sharing your device. This means that you can easily keep track of your data separately by simply switching profiles, so User 1, User 2 and Guest profiles can all have different sets of data. The profile on the console also corresponds to the app. You will be prompted to select a profile in the app when you set up your account and connect to the elliptical for the first time.

If you have selected the User 1 profile, then someone else can become User 2 (and vice versa). From that point forward, the app will check to make sure the console is toggled to the correct user profile and will automatically send a command to the elliptical to update the console profile as needed.

You will always have the option to proceed as Guest. Anyone can connect to the elliptical as Guest. Any user connected as Guest will have the data from the elliptical synced to their app.

IV. Using Your Cubii Go+

NOTE - If you have opted to set your app as User 1 or User 2 but decide to exercise without the app actively connected, then make sure that the console is toggled onto the correct user profile. Without an active connection with the app, the data will be attributed to whichever User profile is selected on the console.

Profile Reset

You can always reset a user profile from the app. This will give another user the opportunity to take that profile spot.

“Smart” Reset

After you connect your elliptical to the app, your Cubii console will reset itself each night at midnight (your local time based on your phone’s settings). This feature will automatically take effect after your first pairing.

Battery Level

The app will detect and display the remaining battery levels from your elliptical.

GENERAL INFORMATION

Return Policy and Warranty

To register for your Cubii elliptical warranty, visit:
cubii.com/register

For more information about our warranty and return policy, visit:
cubii.com/warranty

Troubleshooting

For troubleshooting and assistance with your Cubii Go+, you can email us at: support@mycubii.com

Care and Maintenance

The safety and integrity designed into Cubii Go+ can only be maintained when Cubii Go+ is regularly examined for damage and wear. It is the sole responsibility of the user/owner to ensure that regular maintenance is performed. Special attention should be given to the following:

- Periodically wipe the unit down with a damp cloth, paying special attention to the metal surface of the wheel tracks. This will help reduce any noise between the wheels and the wheel track.
- Worn or damaged components shall be replaced immediately or Cubii Go+ removed from service until repair is made. Email Fitness Cubed Inc at support@mycubii.com to request replacement parts.
- Only Fitness Cubed Inc supplied components shall be used to maintain/repair Cubii Go+.

Important Health & Safety Instructions

Read and follow these instructions:

- Cubii Go+ has been designed to be used only while sitting. Do not stand on the pedals as it was not designed to be used while standing.
- Do not subject Cubii Go+ to heavy shock or treat it excessively. Do not attempt to disassemble or modify it.
- Use Cubii Go+ indoors on a level surface. Keep it away from moisture and dust.
- Do not expose Cubii Go+ to extremely high or low temperatures. Do not leave Cubii Go+ in direct sunlight for an extended period of time.
- Do not place Cubii Go+ in a location where it may cause an obstruction.
- Do not use cleaners or solvents to clean Cubii Go+.
- Do not use any lubricants. They can damage the unit.
- Warning: Risk of fire and burns. Do not open, crush, heat above 45^o C or incinerate. Follow manufacturer's instructions.
- Warning: This stationary training equipment is not suitable for high accuracy purposes.
- This appliance is not intended for use by persons (including children) with reduced physical, sensory or mental capabilities, or lack of experience and knowledge, unless they have been given supervision or instruction concerning use of the appliance by a person responsible for their safety. Children should be supervised to ensure that they do not play with the appliance.
- This appliance can be used by children aged from 8 years and above and persons with reduced physical, sensory or mental capabilities or lack of experience and knowledge if they have been given supervision or instruction concerning use of the appliance in a safe way and understand the hazards involved. Children shall not play with the appliance. Cleaning and user maintenance shall not be made by children without supervision.
- Consult your physician before starting this or any exercise program. This is especially important if you are over the age of 35 or have any pre-existing health condition. If you feel faint or dizzy, immediately

discontinue use of this equipment. Serious bodily injury can occur if this equipment is not assembled and used correctly. Serious bodily injury can also occur if all instructions are not followed. Keep others and pets away from equipment. Follow all safety instructions in this manual.

Sensors and Motors

Your Cubii uses an RPM sensor that measures number of revolutions to help you determine calories burned, distance traveled, and number of strides. Your Cubii also includes a resistance level sensor to measure which resistance setting has been selected and is in use.

Regulatory Notices

1. This device complies with Part 15 of FCC Rules. Operation is subject to the following two conditions:
 - (1) This device may not cause harmful interference, and
 - (2) This device must accept any interference received, including interference that may cause undesired operation.
2. Changes or modifications not expressly approved by the party responsible for compliance could void the user's authority to operate the equipment.

NOTE: This equipment has been tested and found to comply with the limits for a Class B digital device, pursuant to Part 15 of the FCC Rules. These limits are designed to provide reasonable protection against harmful interference in a residential installation. This equipment generates uses and can radiate radio frequency energy and, if not installed and used in accordance with the instructions, may cause harmful interference to radio communications. However, there is no guarantee that interference will not occur in a particular installation. If this equipment does cause harmful interference to radio or television reception, which can be determined by turning the equipment off and on, the user is encouraged to try to correct the interference by one or more of the following measures:

V. General Information

- Reorient or relocate the receiving antenna.
- Increase the separation between the equipment and receiver.
- Connect the equipment into an outlet on a circuit different from that to which the receiver is connected.
- Consult the dealer or an experienced radio/TV technician for help.

RF warning statement:

The device has been evaluated to meet general RF exposure requirement. The device can be used in portable exposure conditions without restriction.

Fitness Cubed Inc is authorized to apply the CE Mark on Cubii, Model F4B3, thereby declaring conformity to the essential requirements and other relevant provisions of:

RED: Radio Equipment Directive: 2014/53/EU

EMC: EMC Directive 2014/30/EU

Safety: General Product Safety Directive 2001/95/EC

ROHS: European Council Directive 2011/65/EU

WEEE: WEEE Directive 2012/19/EU

Reach: Reach Regulation (EC) No. 1907/2006

CAN ICES-003 (B) / NMB-003 (B)

This device contains license-exempt transmitter(s)/receiver(s) that comply with Innovation, Science and Economic Development Canada's license-exempt RSS(s). Operation is subject to the following two conditions:

- (1) This device may not cause interference.
- (2) This device must accept any interference, including interference that may cause undesired operation of the device.

L'émetteur/récepteur exempt de licence contenu dans le présent appareil est conforme aux CNR d'Innovation, Sciences et Développement économique Canada applicables aux appareils radio exempts de licence. L'exploitation est autorisée aux deux conditions suivantes :

- 1) L'appareil ne doit pas produire de brouillage;
- 2) L'appareil doit accepter tout brouillage radioélectrique subi, même si le brouillage est susceptible d'en compromettre le fonctionnement

Model No: F4B3

Net Weight: 20.5lb (9.3kg)

Gross Weight: 24.3lb (11kg)

Product Size: 24.8"L x 17.3"W x 8.9"H (63cm x 44cm x 22.7cm)

Packaged Size: 25.8"L 11.2"W x 11.2"H (65.5cm x 28.5cm x 28.5cm)

Maximum Bearing Weight: 300lbs. (136.08kg)

Durability Class: HC

FCC ID: 2AF6U-F4B3

IC: 27526-F4B3

Designed in Chicago, IL

320 W Ohio Street Suite 700 Chicago, IL 60654

Made in China





Customer Support

support@mycubii.com

cubii.com/help

+1-844-282-4401