

Cubii® JR1+

COMPACT SEATED ELLIPTICAL

Owner's Manual

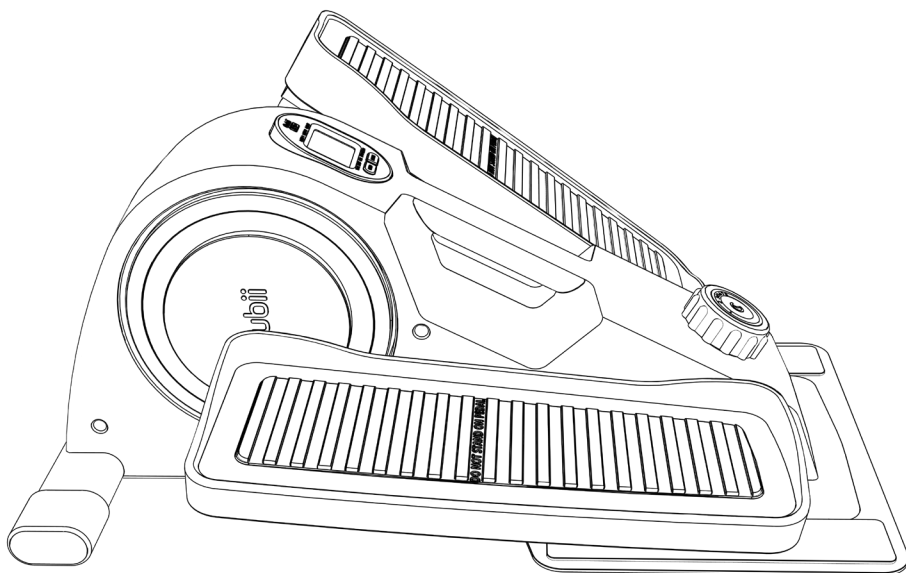

TABLE OF CONTENTS

Before You Begin	2
Safety Instructions	
Consult Your Physician	
Getting Started	4
Product Size and Weight	
What's in the Box	
Warning Labels	
Serial Number Location	
Assembling Your Unit	6
Using Your Cubii JR1+	8
Positioning	
Adjusting the Resistance	
Charging Your Cubii Elliptical	
Battery Life and Power	
Reading the Display Console	
Installing and Pairing with the Cubii App	
Bluetooth® Related App Features	
General Information	17
Return Policy and Warranty	
Troubleshooting	
Sensors and Motors	
Care and Maintenance	
Important Health & Safety Instructions	
Regulatory Notices	

Welcome to the Cubii Communitii™!

Whether you are taking the first step on your fitness journey or looking to get more exercise from the comfort of home, bringing the Cubii JR1+ into your routine is a big stride toward a healthier, more active life! Before you begin, we want you to be familiar with important information on how to use the Cubii JR1+ safely so that you and your loved ones get the most out of your experience.

Let's review the safety notes and warnings now.

If you have any questions, please contact:

1-844-282-4401

support@mycubii.com

cubii.com/help

BEFORE YOU BEGIN

Safety Warnings & Instructions

WARNING Consult your physician before starting this or any exercise program. This is especially important if you have never exercised before, are pregnant, or suffer from any health problems. If at any time during exercise you feel faint, dizzy, or experience pain, stop and consult your physician.

WARNING Do not use when standing. Only use when sitting. Failure to follow all warnings and instructions could result in serious injury or death.

WARNING To reduce the risk of serious injury, read the following Safety Instructions before using Cubii JR1+.

1. Read all warnings and cautions posted on the Cubii JR1+ unit.
2. Cubii JR1+ should only be used after a thorough review of the Owner's Manual.
3. We recommend that two people are available for assembly of this product.
4. Do not allow children to use or play on Cubii JR1+. Keep children and pets away from Cubii JR1+ when it is in use.
5. Set up and operate Cubii JR1+ on a solid, level surface. Do not position Cubii JR1+ on loose rugs or uneven surfaces.
6. Make sure that adequate space is available for access to and around Cubii JR1+.
7. Before using, inspect Cubii JR1+ for worn or loose components. Securely tighten or replace any worn or loose components prior to use.
8. Do not wear loose or dangling clothing while using Cubii JR1+.

9. Follow your physician's recommendations in developing your own personal fitness program.
10. Always choose a workout plan which best fits your fitness and ability level. Know your limits and train within them. Always use common sense when exercising.
11. Be careful to maintain your balance on your chair while using, mounting, dismounting, or assembling Cubii JR1+; loss of balance may result in a fall and serious bodily injury.
12. Keep both feet firmly and securely on the pedals while exercising.
13. Maximum recommended user weight is 300 pounds (136 kg). Never stand on the pedals, no matter your weight.
14. Cubii JR1+ should be used by only one person at a time.

Consult Your Physician

It is always important to consult your physician before starting an exercise program. This is particularly true if any of the following apply to your current medical condition:

- Chest pain or pain in the neck and/or arm
- Shortness of breath
- A diagnosed heart condition
- Joint and/or bone problems
- Currently taking cardiac and/or blood pressure medications
- Have not previously been physically active
- Dizziness or blurred vision
- Those with physical handicaps

If you feel any of the physical symptoms listed above when you start your exercise program, contact your physician right away.

GETTING STARTED

Product Size and Weight

The assembled Cubii JR1+ measures:

23.2"L x 17.6"W x 9.8"H (58.8cm x 44.6cm x 24.8cm)

The weight of the unit is approximately 25.7lb (11.6kg).

What's in the Box

JR1+ Main Body

Left Pedal

Right Pedal

Screwdriver

Screws (x4)

Charging Cable

AC Power Adapter

Chair Wheel Stoppers (x2)

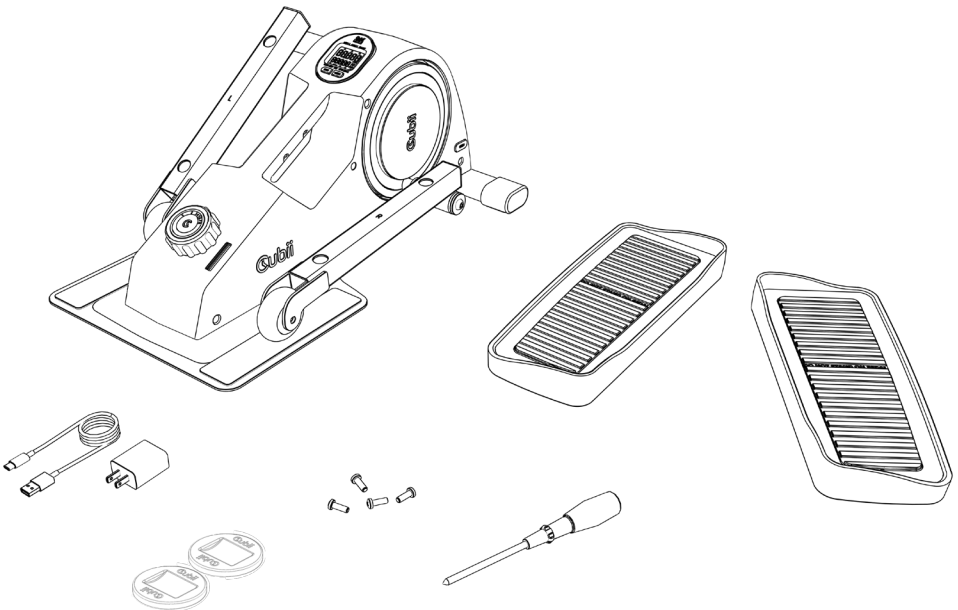

Warning Labels

The warning label is located on your Cubii JR1+ product here:

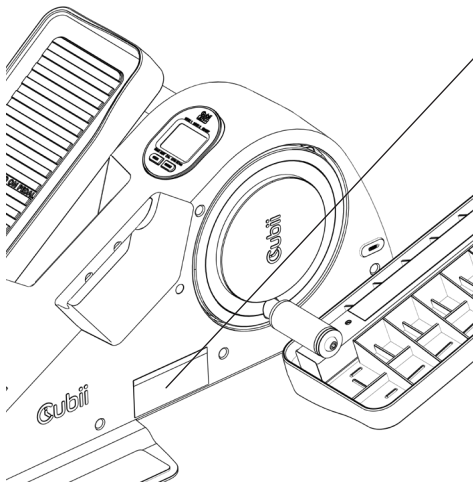

WARNING

Failure to follow all warnings and instructions could result in serious injury or death. Before assembling or using this product, read and follow the Owner's Manual and all other instructions that accompany this product. Replace this warning label if damaged, illegible, or removed.

Keep others including children and pets away from equipment.

Consult your physician before starting this or any exercise program. This is especially important if you are over the age of 35 or have any preexisting health condition. Always make sure all nuts and bolts are securely tightened before using this product. The maximum weight that can be applied is 300 lb or 136 kg.

**DO NOT USE WHILE STANDING. USE ONLY WHEN SITTING.
STANDING ON THE UNIT MAY CAUSE SERIOUS INJURY.**

Serial Number Location

The serial number is located on your Cubii JR1+ product here:

Product Label

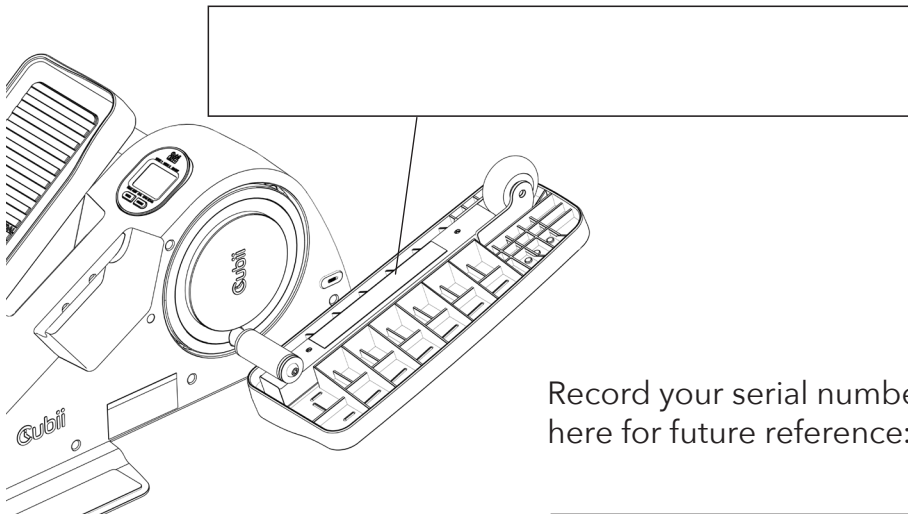

Record your serial number here for future reference:

ASSEMBLING YOUR UNIT

Follow the steps below to assemble your JR1+ compact elliptical.

Step 1 – Align

Align the right pedal with the right arm.
Insert the bottom of the pedal into the two small holes.

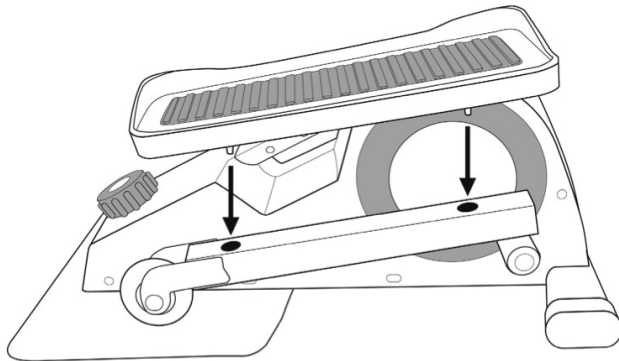

Step 2 – Flip

For maximum support, make sure you flip the pedal you are assembling so it is at the bottom and close to the base.

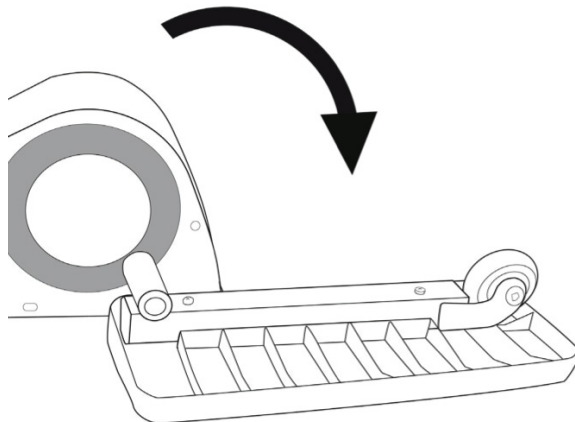

Step 3 – Screw

With a screwdriver, screw in the pedal until tight. Make sure it does not wobble.

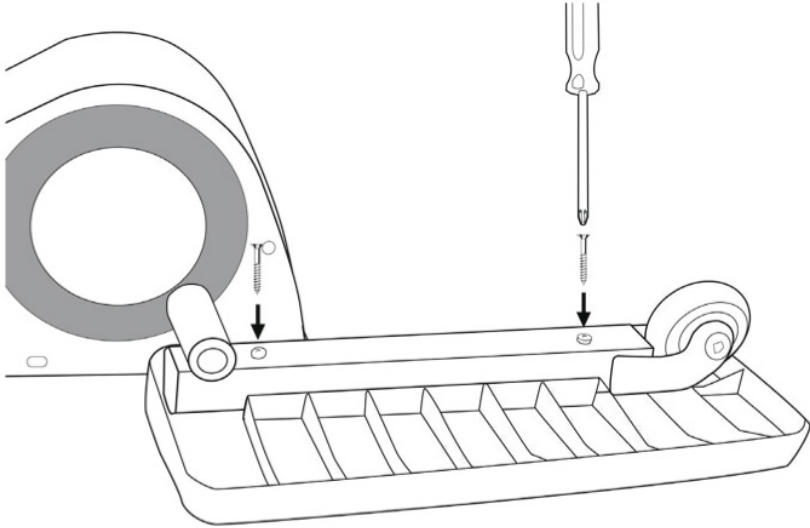

Step 4 – Repeat

Repeat steps 1-3 with the left pedal, then get moving!

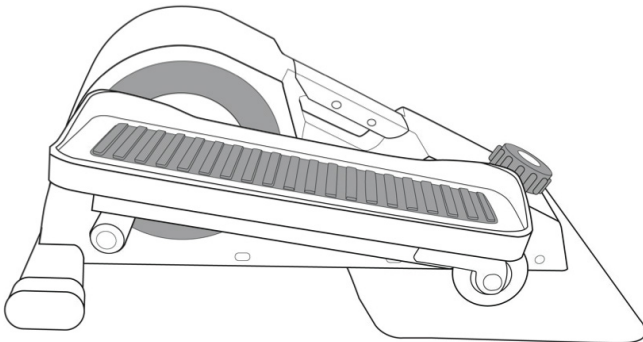

USING YOUR CUBII JR1+

Make sure to have followed all of the assembly steps in the Quick Start guide before you begin using Cubii JR1+.

Positioning

The Cubii JR1+ can be used either in an upright position, such as with an office chair, or in a more reclined position, such as when used on a sofa.

- Cubii JR1+ occupies a floor area of 23.2" x 17.6" (0.59m x 0.45m). Please leave a clear zone behind the training area that is at least 0.60m (24"). This zone must be clear of any obstruction and provide the user a clear exit path.
- Find the seat configuration that suits you most. If you feel there is not enough room between your knees and the desk, push your Cubii JR1+ away from you and lower the chair height. Keep your back straight, and do not slouch.
- If you are sitting on an office chair with wheels, use the chair wheel stoppers. Place stoppers on the front casters to prevent your chair from moving backwards when you pedal.
- For swiveling chairs with more than 4 casters, you may find it more convenient to use only one wheel stopper centered close to the machine.

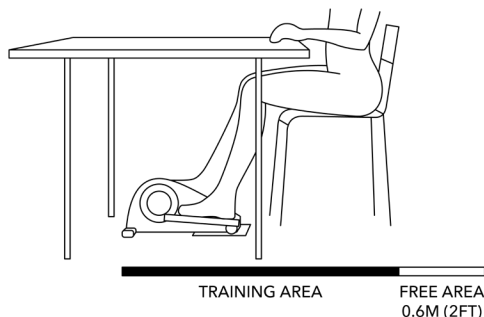

Adjusting the Resistance

Cubii JR1+ has 8 resistance levels. Adjust your workout intensity by turning the resistance control knob. Level 1 is the lowest intensity and level 8 is the highest. We recommend you begin at Level 1 and increase the intensity gradually over time.

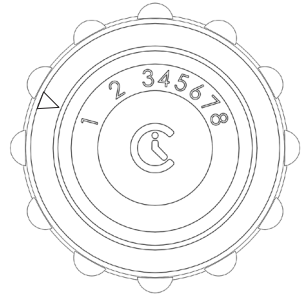

CHARGING YOUR CUBII ELLIPTICAL

Step 1 – Connect Wall Adapter

Connect the charging cable to the wall adapter and ensure wall adapter is plugged into power source.

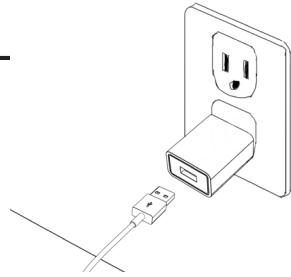

Step 2 - Locate Charging Socket

Locate the charging port on your Cubii elliptical and plug in the cable.

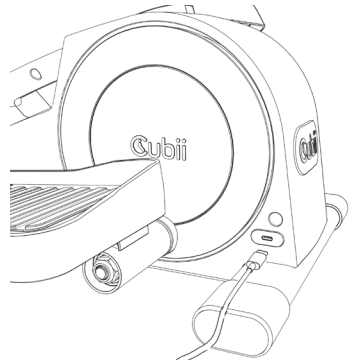

Step 3 - Check Display for Charging Symbol

Once the charging cable is plugged in and charging your elliptical, the screen will power on and the lightning bolt symbol will flash to indicate the charge in progress. The lightning bolt symbol will remain solid when it is fully charged.

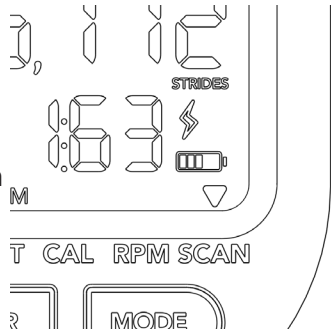

Battery Life and Power

The screen on your JR1+ comes equipped with a rechargeable lithium-ion battery. With normal use, your Cubii elliptical should last about 30 days before you need to charge again. Charging your JR1+ completely can take up to 6 hours. You can check the battery level in the Cubii app or on the built-in screen.

READING THE DISPLAY CONSOLE

User Options

Your Cubii JR1+ elliptical can store data separately for User 1, User 2, and Guest. Press the User button to switch Users. The triangle indicates the selected User. You can also track each User's progress through the Cubii app.

Top Row

The top row displays your total number of strides. A "stride" is the equivalent of one full rotation of the pedaling motion.

Bottom Row

The bottom row displays the following metrics:

- Time (00:00:00-99:59:59 hour:min:sec) elapsed during active workout
- Distance (000.00-999.99 mi or km) pedaled during a workout
- Calories (000.00-999.9 kcal) during a workout
- RPM (0-999 strides/min) rotations per minute during a workout

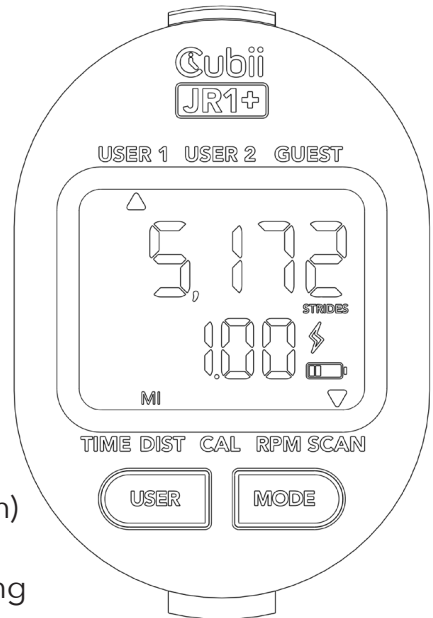

Press the MODE button to switch which metric is displayed. You can use the SCAN mode to automatically toggle between the above metrics every 7 seconds. The triangle indicator shows which view is selected.

BLUETOOTH® Wireless Technology Indicator

The Bluetooth symbol will flash when your JR1+ is available to connect to your mobile device or tablet. The Bluetooth® symbol will remain solid once your elliptical is connected to the Cubii mobile app. Your elliptical must be charged in order to pair with another device.

Battery Indicator

The number of bars in the battery symbol indicates the charge left in the battery. When the battery symbol reaches 0 bars, it will flash for 20 seconds, indicating that it requires charging. The battery symbol will flash during charging when battery level is below 100%. It will remain solid when charging is complete, but still plugged in. The symbol will disappear when your elliptical is not charging.

“Smart Reset”

All metrics are additive and counted throughout the day. Once you have paired the mobile app with your Cubii, then the metrics displayed on the console will automatically reset each evening at midnight (as long as your Cubii battery does not deplete). If you have not paired the mobile app with your Cubii, then the data will continue to aggregate unless you manually reset the data or manually setup the “smart reset” feature (see section below entitled *Manually Set a “Smart Reset”*).

*The Bluetooth® word mark and logos are registered trademarks owned by Bluetooth SIG, Inc. and any use of such marks by Fitness Cubed Inc is under license. Other trademarks and trade names are those of their respective owners.

Console Profile Reset

User 1 and User 2 profiles can be reset from the console. Simply select the relevant user profile then hold the User button for 3 seconds then release the button to complete the profile reset. Resetting the user profile from the built-in console erases any data stored for that profile and also delinks the profile from the app. The profile can be easily re-established in the app if needed.

Manual Data Reset

Manually reset data for any profile on the console (User 1, User 2 or Guest) by selecting the relevant profile (see User Button section above) and then holding the Mode button for 3 seconds then release the button to complete the profile reset. This action resets any data displayed on the screen for the selected profile.

Distance Metric Toggle

To switch from miles to kilometers (or kilometers to miles), use the MODE button to select the Distance metric. Then, hold the MODE button for 6 seconds. If you are using the Cubii app, this update will also be reflected there.

Manually Set a "Smart Reset"

If you do not pair your elliptical to the Cubii app, but still want your console to reset each evening at midnight, follow the instructions below to set the clock to the current time:

1. Simultaneously press the USER and MODE buttons 3 times in a row to reset the clock. It should flash "00:00".
2. Press the USER button to cycle through hours until you get to the right hour. Note that the clock uses military time.
3. Press the MODE button to cycle through minutes until you get to the right minute.

4. Once you have entered the current time, simultaneously press the USER and MODE buttons 3 times in a row to save the time.

If there is no activity for more than 5 seconds during this process, the reset will be cancelled.

The “smart reset” feature is ONLY activated if the user performs the manual actions above to set the RTC on the console (or it will automatically be applied if the user connects their app). If you do not choose to manually set the clock following the instructions above, and do not connect to the Cubii app, your console will continue to add and display all data until you manually reset the screen.

Please note the “smart reset” function and clock setting will only remain while the battery retains enough capacity to power the device. If the battery is depleted, the “smart reset” feature must again be manually established using the above instructions.

Connecting with Devices

Your Cubii JR1+ is a connected Bluetooth® Low Energy device, meaning it can pair directly with the Cubii mobile app to automatically track your workouts. The app also supports many other features such as viewing your workout history, setting goals and tracking against them, creating or participating in group leaderboards, chatting with friends and much more.

Supported Devices

Your JR1+ can sync with select mobile devices that support Bluetooth® 4.0 technology. Currently, we support iPhone mobile devices running iOS® 12.0 or higher. (Note that supported versions are subject to change over time. After you’ve created an account, Cubii will inform you if/when your device requires an update).

Installing the Cubii App

To download the app for a device, search for “Cubii” in your app store. Click “Install”/ “Get”. Once it’s finished installing, click “Open.” Once you open the app, you will be prompted to create an account. If you already have the Cubii app installed, check for available updates to make sure you have the latest version.

Pairing your Cubii Elliptical with the Cubii App

In order to pair with the Cubii app, please follow these instructions:

1. Start pedaling to trigger the Bluetooth® signal. You’ll see the Bluetooth® symbol glow and start blinking.
2. Confirm that you’ve enable Bluetooth wireless technology in your device’s settings.
3. Upon opening the Cubii app for the first time, you will be prompted to create an account. Be sure to review/ accept the Terms of Use and Privacy Policy.
4. Complete your profile and follow the other in-app instructions.
5. The app will detect your Cubii elliptical via Bluetooth®. Select your elliptical in the app.
6. Once successfully paired, the Bluetooth® symbol on your built-in screen will stop blinking.
7. The app will ask if you would like to become User 1, User 2, or proceed as Guest. Make a selection.

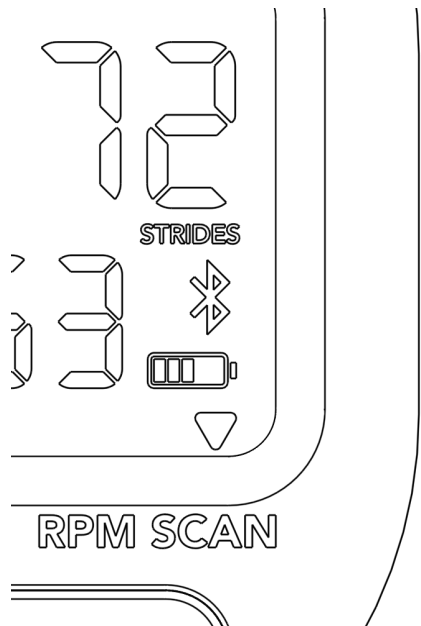

8. Start your workout and enjoy your Cubii experience!
9. From here on, every time you launch the app, it will search for all Cubii devices in your vicinity and automatically connect with an elliptical that it has already paired with. If it does not automatically reconnect, you can manually search and connect it in the app.

In order to pair with a new Cubii elliptical in the same vicinity, you must first disconnect from the previous Cubii elliptical. This can be done in the app. Your elliptical can also only pair to one app user at a time. To allow another user to connect their app to the elliptical, you must first disconnect.

Offline Mode

The Cubii app should remain open in the background in order for Cubii to send data to your device. If the app is not open, then the Cubii itself will store your workout data until the next time your app is paired, at which point the data will be retrieved. The exercise stats will be attributed to the date/time they occurred.

BLUETOOTH® Related App Features

In addition to the automated tracking and storing of your workout data, the mobile app also offers a few other features specifically related to the Bluetooth® connectivity. Each of the capabilities listed below are available when your elliptical is actively paired with the app.

Distance Metric Toggle

Switch from miles to kilometers, or kilometers to miles, by switching the setting in the mobile app. When this action is taken, the app communicates the change to the elliptical console so it displays the appropriate distance metric.

Resistance Level

The Cubii app will automatically retrieve the resistance level from the elliptical. However, please note that the app CANNOT update the resistance on the elliptical itself. The resistance is managed by the elliptical and the app reads that information.

User 1, User 2 and Guest Profiles

Your Cubii elliptical offers multiple user profiles on the console in the event that you plan on sharing your device. This means that you can easily keep track of your data separately by simply switching profiles, so User 1, User 2 and Guest profiles can all have different sets of data. The profile on the console also corresponds to the app. You will be prompted to select a profile in the app when you set up your account and connect to the elliptical for the first time.

If you have selected the User 1 profile, then someone else can become User 2 (and vice versa). From that point forward, the app will check to make sure the console is toggled to the correct user profile and will automatically send a command to the elliptical to update the console profile as needed.

You will always have the option to proceed as Guest. Anyone can connect to the elliptical as Guest. Any user connected as Guest will have the data from the elliptical synced to their app.

NOTE - If you have opted to set your app as User 1 or User 2 but decide to exercise without the app actively connected, then make sure that the console is toggled onto the correct user profile. Without an active connection with the app, the data will be attributed to whichever User profile is selected on the console.

Profile Reset

You can always reset a user profile from the app. This will give another user the opportunity to take that profile spot.

“Smart” Reset

After you connect your elliptical to the app, your Cubii console will reset itself each night at midnight (your local time based on your phone’s settings). This feature will automatically take effect after your first pairing.

Battery Level

The app will detect and display the remaining battery levels from your elliptical.

GENERAL INFORMATION

Return Policy and Warranty

To register for your Cubii elliptical warranty, visit:
cubii.com/register

For more information about our warranty and return policy, visit:
cubii.com/warranty

Troubleshooting

For troubleshooting and assistance with your Cubii JR1+, you can email us at: **support@mycubii.com**

Sensors and Motors

Your Cubii uses an RPM sensor that measures number of revolutions to help you determine calories burned, distance traveled, and number of strides. Your Cubii also includes a resistance level sensor to measure which resistance setting has been selected and is in use.

Care and Maintenance

The safety and integrity designed into Cubii JR1+ can only be maintained when Cubii JR1+ is regularly examined for damage and wear. It is the sole responsibility of the user/owner to ensure that regular maintenance is performed.

Special attention should be given to the following:

- Periodically wipe the unit down with a damp cloth, paying special attention to the rubber padding on the wheel tracks. This will help reduce any noise between the wheels and the wheel track.
- Pay special attention to how tightly the pedals are screwed to the pedal arms. Tighten regularly using a screwdriver.
- Worn or damaged components shall be replaced immediately or Cubii JR1+ removed from service until repair is made. Email Fitness Cubed, Inc at **support@mycubii.com** to request replacement parts.
- Only Fitness Cubed, Inc supplied components shall be used to maintain/repair Cubii JR1+.

USE ONLY WHILE SITTING, DO NOT STAND ON THE UNIT UNDER ANY CIRCUMSTANCE.

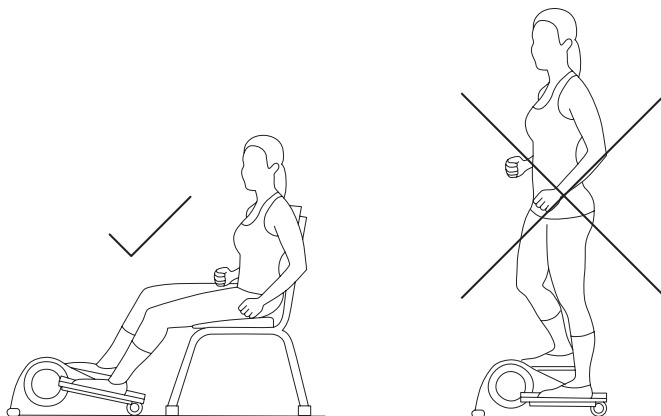

Important Health & Safety Instructions

Consult your physician before starting this or any exercise program. This is especially important if you are over the age of 35 or have any preexisting health conditions. If you feel faint or dizzy, immediately discontinue use of this equipment. Serious bodily injury can occur if this equipment is not assembled and used correctly. Serious bodily injury can also occur if all instructions are not followed. Keep others and pets away from equipment when in use.

Read and follow these instructions:

- Cubii JR1+ has been designed to be used only while sitting. Do not stand on the pedals as it was not designed to be used while standing.
- Make sure the pedals on Cubii JR1+ are tight before use. Loose pedals will slowly come undone, create noise, and cause risk of damage and injury.
- Do not subject Cubii JR1+ to heavy shock or treat it with excessive force. Do not attempt to disassemble or modify it.
- Use Cubii JR1+ indoors on a level surface. Keep it away from moisture and dust.
- Do not expose Cubii JR1+ to extremely high or low temperatures. Do not leave Cubii JR1 in direct sunlight for an extended period of time.
- Do not place Cubii JR1+ in a location where it may cause an obstruction.
- Do not use cleaners or solvents to clean Cubii JR1+.
- Do not use any lubricants. They can damage the unit.
- Warning: Risk of fire and burns. Do not open, crush, heat above 45° C or incinerate. Follow manufacturer's instructions.

V. General Information

Regulatory Notices

1. This device complies with Part 15 of FCC Rules. Operation is subject to the following two conditions:

- (1) This device may not cause harmful interference, and
- (2) This device must accept any interference received, including interference that may cause undesired operation.

2. Changes or modifications not expressly approved by the party responsible for compliance could void the user's authority to operate the equipment.

NOTE: This equipment has been tested and found to comply with the limits for a Class B digital device, pursuant to Part 15 of the FCC Rules. These limits are designed to provide reasonable protection against harmful interference in a residential installation. This equipment generates uses and can radiate radio frequency energy and, if not installed and used in accordance with the instructions, may cause harmful interference to radio communications. However, there is no guarantee that interference will not occur in a particular installation. If this equipment does cause harmful interference to radio or television reception, which can be determined by turning the equipment off and on, the user is encouraged to try to correct the interference by one or more of the following measures:

- Reorient or relocate the receiving antenna.
- Increase the separation between the equipment and receiver.
- Connect the equipment into an outlet on a circuit different from that to which the receiver is connected.
- Consult the dealer or an experienced radio/TV technician for help.

RF warning statement:

The device has been evaluated to meet general RF exposure requirement. The device can be used in portable exposure conditions without restriction.

Fitness Cubed Inc is authorized to apply the CE Mark on Cubii, Model F4A2, thereby declaring conformity to the essential requirements and other relevant provisions of:

RED: Radio Equipment Directive: 2014/53/EU

EMC: EMC Directive 2014/30/EU

Safety: General Product Safety Directive 2001/95/EC

ROHS: European Council Directive 2011/65/EU

WEEE: WEEE Directive 2012/19/EU

Reach: Reach Regulation (EC) No. 1907/2006

U.S. Patent No. D793,494

U.S. 9713739 B2

CAN ICES-003 (B) / NMB-003 (B)

This device contains license-exempt transmitter(s)/receiver(s) that comply with Innovation, Science and Economic Development Canada's license-exempt RSS(s).

Operation is subject to the following two conditions:

- (1) This device may not cause interference.
- (2) This device must accept any interference, including interference that may cause undesired operation of the device.

L'émetteur/récepteur exempt de licence contenu dans le présent appareil est conforme aux CNR d'Innovation, Sciences et Développement économique Canada applicables aux appareils radio exempts de licence. L'exploitation est autorisée aux deux conditions suivantes :

- 1) L'appareil ne doit pas produire de brouillage;
- 2) L'appareil doit accepter tout brouillage radioélectrique subi, même si le brouillage est susceptible d'en compromettre le fonctionnement

Model No: F4A2

Net Weight: 25.7lb, 11.6 kg

Size: 23.2"L x 17.6"W x 9.8"H (58.8cm x 44.6cm x 24.8cm)

Maximum Bearing Weight: 300lbs. (136.08kg)

Durability Class: HC

Battery Type: Li-ion Rechargeable Battery

Battery Rating: 3.7V 2200mAh 8.14Wh

FCC ID: 2AF6U-F4A2

IC: 27526-F4A2

Designed in Chicago, IL
350 W Ontario STE 4 Chicago, IL 60654
Made in China





Customer Support

support@mycubii.com

cubii.com/help

1-844-282-4401