

# RAK7431

## RS485 to LoRaWAN Converter

Version V1.2 | January, 2020



[www.RAKwireless.com](http://www.RAKwireless.com)

*Visit our website for more document.*



## Table of Contents

<b>1 Overview .....</b>	<b>3</b>
1.1 Introduction .....	3
1.2 Main Features .....	4
<b>2 RAK7431 Networking Applications .....</b>	<b>5</b>
<b>3 Interfaces .....</b>	<b>8</b>
<b>4 RAK7431 Specifications .....</b>	<b>10</b>
<b>5 Installation .....</b>	<b>11</b>
<b>6 Revision History .....</b>	<b>13</b>
<b>7 Document Summary .....</b>	<b>13</b>

# 1 Overview

## 1.1 Introduction

RAK7431 is an RS485 to LoRaWAN™ converter designed for industrial applications. The device relays ModBUS data using the LoRaWAN™ network as means of wirelessly transmitting to and from the end devices.

RAK7431 can operate in all of the LoRaWAN™ bands within the standard parameters defined by the LoRa® Alliance. Its open environment range is 15+km and in industrial cases, where there are heavy obstructions in the path of the RF signal performance is improved compared to conventional wireless systems due to the characteristics of LoRa® as a modulation technique. This allows for consistently good signal quality within the confines of large factories, densely populated offices, storehouses, etc.

This RS485 compatible devices can address up to 16 client terminal nodes. The conversion from and to LoRa® frames is seamless and allows for real time control and monitoring of multiple RS485 devices. bus data to access and control the RS485 terminal nodes.

RAK7431 together with RAK's LoRaWAN™ gateway and LoRa® Server products, can easily and quickly build a wireless industrial field control system.

RAK7431 adopts industrial protection design, supports wide range voltage supply, supports wall mounting and DIN rail installation, facilitates field installation and use.

## 1.2 Main Features

- **LoRaWAN™ 1.0.2** protocol stack, supports Class A & C
- **Working modes:** Polling mode, transparent mode and packet mode
- Remote cloud management of RS485 devices
- Can address up to **16 RS485**, a que with up to **32 instruction sets**
- Industrial grade STM MCU: ultra-low power (**4uA sleep**)and wide temperature range of operation.
- Wide range of input voltages, **8-48V DC input**
- Can power RS485 devices via a dedicated output.
- Mounting: Wall, DIN rail, and magnetic mounting
- Compliant with IEC61000-4-2, IEC61000-4-4 and 18KV HMB ESD protection
-

## 2 RAK7431 Networking Applications

RAK7431 can convert the data of RS485 devices into LoRaWAN™ that can be sent to the cloud via a standard LoRaWAN™ Gateway. Cloud servers can also actively send data to RS485 terminals to achieve two-way data transmission. Using RAK7431, what used to be a costly and time-consuming cable line network deployment can be transformed into a rapid and cost-efficient wireless network deployment.

An example would be using the RAK7249 LoRaWAN™ Gateway coupled with the RAK WisDM cloud management platform, in order to realize an end-to-end industrial field data acquisition and control system. Using the built-in LoRa® Server, that comes standard with any RAK LoRaWAN™ Gateway, one could seamlessly achieve transmission of the end device data to any application server. Furthermore, the MQTT integration allows for a high level of security and efficiency.



Figure 1 | RS485 to LoRaWAN™ network structure

RAK7431 can work in polling mode in order to send query instructions to RS485 nodes, and convert the data returned into LoRa® frames to be relayed to the application server via a LoRaWAN™ Gateway.



**Figure 2 | RAK7431 polling mode**

RAK7431 can store a maximum of 32 query instructions in polling mode, each of which has a maximum length of 128 bytes. Polling time interval and waiting time can be adjusted as required.

RAK7431 converts the data returned by RS485 nodes into LoRa® packets that can be sent to LoRaWAN™ Gateway in two ways: transparent or packet.

- In transparent mode, RS485 data is encapsulated in the payload of LoRa® frames as it is.
- In packet mode, RS485 data is encapsulated in LoRa® frames with the addition of a header and verification.

No matter whether polling mode is enabled or not, the server can actively send commands to query the RS485 nodes through the LoRaWAN™ Gateway via the RAK7431. The commands issued and the returned data can also be transmitted in transparent mode or in packet mode.

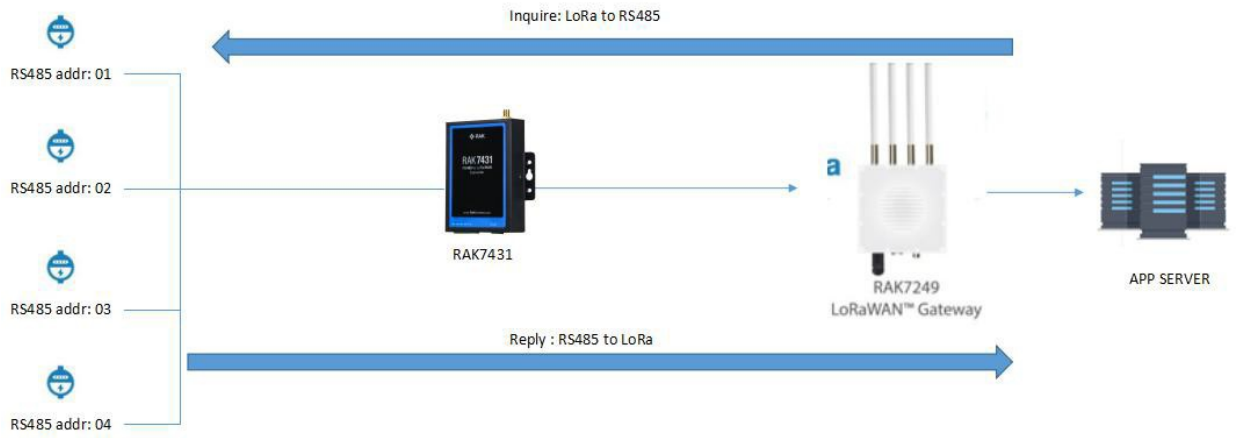

**Figure 3** | RAK7431 transparent mode

### 3 Interfaces

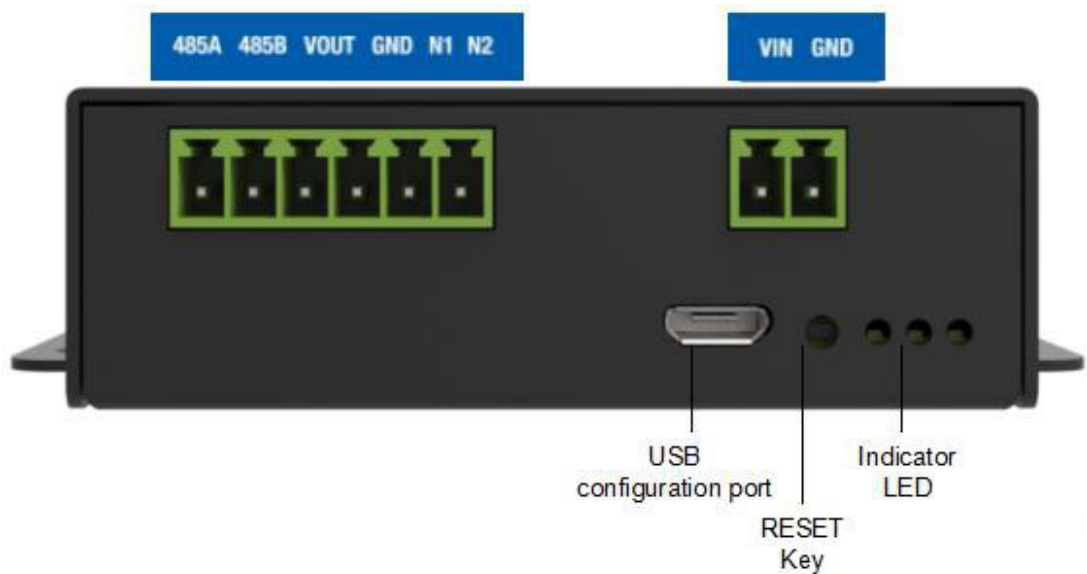

Figure 4 | RAK7431 bottom panel

#### Power supply and configuration interface:

RAK7431 can be powered by its DC terminal or via its Micro USB port.

The DC terminal accepts 8-48V DC input, and the rated power of the device is 1W. Pay attention to the positive and negative pole directions when crimping the terminal. Vin is connected to the positive pole of the power supply, and GND is connected to the negative pole of the power supply.

The Micro USB port can also be used for powering the device (5V / 500mA DC).

At the same time, the Micro USB port can be used as the configuration interface of the device. Connect it to a PC and use the [RAK Serial Port Tool](#) to open a COM port. The default baud rate is 115200. There is a standard set of AT commands that can be used to configure the RAK7431.

#### Data interface:

When connecting to RS485 nodes, please connect 485A and 485B on the data interface of RAK7431 with the A and B lines of the RS485 bus. Connect the GND terminal to the GN line of the RS485 devices. The RS485 bus carrying capacity of RAK7431 goes up to 16 RS485 terminals at the same time.

The Vout on the data interface can supply power to the RS485 terminals (**only valid when using the DC input interface power supply, USB power supply is invalid**). The Vout output voltage is the same as DC input voltage Vin.



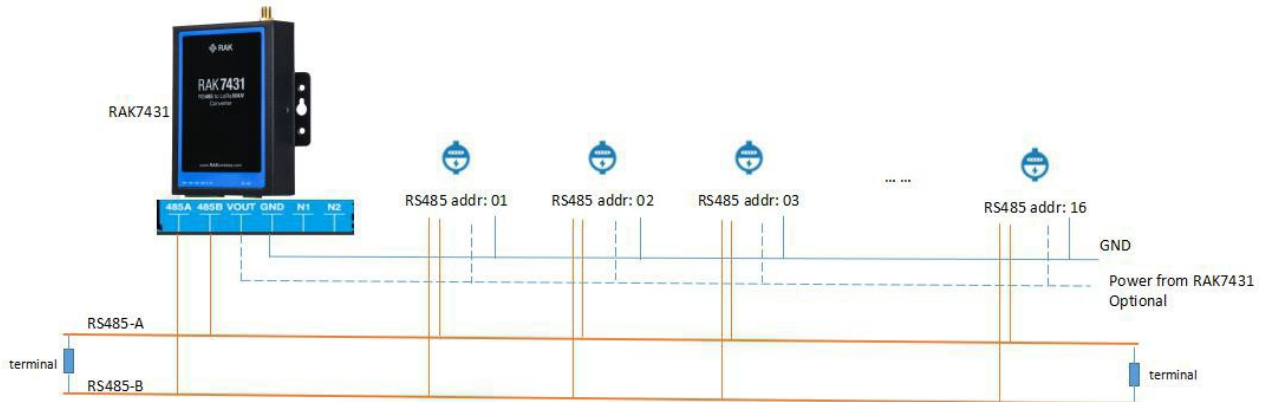

Figure 5 | RAK7431 ModBus connection diagram

**Reset key and indicator LED:**

Reset Key	Press the reset key shortly to restart the system
Red LED	Power indicator (Only valid when using the USB power)
Green LED	System working indicator, flashing when there is data transmission



## 4 RAK7431 Specifications

Parameter	Value	Remarks
LoRaWAN™ Protocol	LoRaWAN™ 1.0.2	
LoRa Frequency	RU864, IN865, EU868, US915, AU915, KR920, KR923	Different models support different frequency bands
LoRaWAN™ Mode	Class A / Class C	
LoRa® Antenna interface	SMA MALE, External omnidirectional Antenna	
RS485 Data Rate	Configurable 9600 -115200bps	
RS485 Carrying Capacity	16 Nodes	
RS485 Protection	18KV HBM protection 13KV IEC61000-4-2 contact discharge 4KV IEC61000-4-4 fast transient burst	
Input Voltage	8-48V	5V for Micro USB
Rated Power	Maximum 1W	
Output Voltage	8-48V	
Configuration Interface	Micro USB	
Indicator LED	Power LED, Data LED	
Housing Material	Metal	
Dimension	93.6 x 100.3 x 24mm	
Protection Grade	IP31	
Installation	Wall mounting, DIN rail installation, magnetic mounting	Magnetic mounting requires optional accessories
Working Temperature	-30°C ~ 65°C	
Storage Temperature	-40°C ~ 85°C	



## 5 Installation

RAK7431 allows for three installation methods: wall mounting, DIN rail installation and magnetic mounting. The wall installation and DIN rail installation is the standard installation mode (screw holes). The accessories required for magnetic mounting are optional.

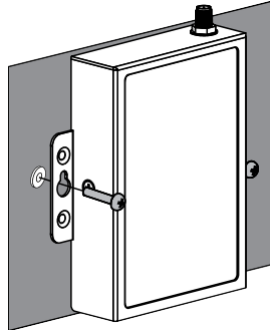

Wall mounting

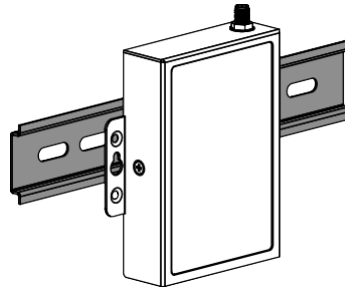

DIN rail installation

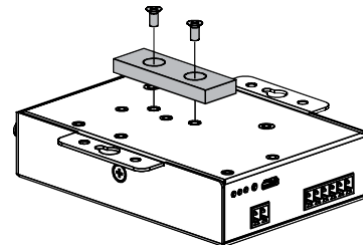

Magnetic mounting

---

**FCC Caution:**

Any Changes or modifications not expressly approved by the party responsible for compliance could void the user's authority to operate the equipment.

This device complies with part 15 of the FCC Rules. Operation is subject to the following two conditions: (1) This device may not cause harmful interference, and (2) this device must accept any interference received, including interference that may cause undesired operation.

**IMPORTANT NOTE:**

Note: This equipment has been tested and found to comply with the limits for a Class B digital device, pursuant to part 15 of the FCC Rules. These limits are designed to provide reasonable protection against harmful interference in a residential installation. This equipment generates, uses and can radiate radio frequency energy and, if not installed and used in accordance with the instructions, may cause harmful interference to radio communications. However, there is no guarantee that interference will not occur in a particular installation. If this equipment does cause harmful interference to radio or television reception, which can be determined by turning the equipment off and on, the user is encouraged to try to correct the interference by one or more of the following measures:

- Reorient or relocate the receiving antenna.
- Increase the separation between the equipment and receiver.
- Connect the equipment into an outlet on a circuit different from that to which the receiver is connected.
- Consult the dealer or an experienced radio/TV technician for help.

**FCC Radiation Exposure Statement:**

This equipment complies with FCC radiation exposure limits set forth for an uncontrolled environment. This equipment should be installed and operated with minimum distance 20cm between the radiator & your body.

## 6 Revision History

Revision	Description	Date
1.0	Initial version	2019-10-09
1.1	Add detailed parameters	2019-12-27
1.2	Product naming and image update, naming errors, some inaccuracy in table data values	2019-01-13

## 7 Document Summary

Prepared by	Checked by	Approved by
Terry & Penn	Terry & Vladislav	



### About RAKwireless:

RAKwireless is a pioneer in providing innovative and diverse Cellular and LoRaWAN connectivity solutions for both Edge and Gateway IoT devices. We believe that through easy to use and modular designs we can accelerate the time to market for various IoT Applications in order to optimize system deployment in both Developer and Commercial settings.