

# RAK4600 LoRa Module

## WisDuo-LoRa Series

Version V1.4 | November2019



[www.RAKwireless.com](http://www.RAKwireless.com)

*Visit our website for more document.*

13 PAGES

## Table of Contents

<b>1. Overview</b> .....	3
1.1 Introduction.....	3
1.2 Main Features .....	3
<b>2. RAK4600 LoRa Module</b> .....	4
2.1 Overview.....	4
2.2 BT and LoRa Antenna position .....	4
2.3 Block Diagram .....	4
2.4 Supported LoRaWAN Bands .....	5
2.5 Pin Definition & Pin Out.....	5
2.6 Power Consumption.....	8
2.7 Mechanical Dimensions.....	8
2.8 Recommended Footprint.....	9
2.9 Recommended Reflow Profile.....	10
2.9 FCC Caution .....	11
<b>3. Revision History</b> .....	13
<b>4. Document Summary</b> .....	13

# 1. Overview

## 1.1 Introduction

RAK4600 LoRa Module includes a nRF52832 MCU and a SX1276 LoRa chip. It has Ultra-Low Power Consumption of 2.0uA in sleep mode, high LoRa output power up to 20dB max in work mode, and BLE output power up to 4dBm.

The module complies with LoRaWAN 1.0.2 protocols. It also supports Lora Point to Point communications. The Module supports BLE 5.0 in addition to LoRa. Its RF communication capabilities (LoRa+BLE) make it suitable for a variety of applications in the IoT field such as home automation , sensor networks, building automation or Personal area networks such as health fitness sensor and monitor devices ,Medical devices.

## 1.2 Main Features

- LoRa module for Smart City, Smart Agriculture, Smart Industry
- Compact Form Factor: 15 x 23 x 2.5 mm
- 42 Pin Stamp Pad for PCB SMT mounting
- I/O ports: UART/I2C/GPIO (optional NFC interface)
- Temperature range: -40°C to +85°C
- Supply voltage: 2.0 ~ 3.6V
- Frequency range: 863–870MHz (EU) / 902–928MHz (US)
- Low-Power Wireless Systems with 7.8kHz to 500KHz Bandwidth
- Ultra-Low Power Consumption 2.0uA in sleep mode
- Serial wire debug(SWD)

## 2. RAK4600 LoRa Module

### 2.1 Overview

The figure below shows the top view of the RAK4600 LoRa Module. The dimensions of the Module are 15 x 23 x 2.5 mm.

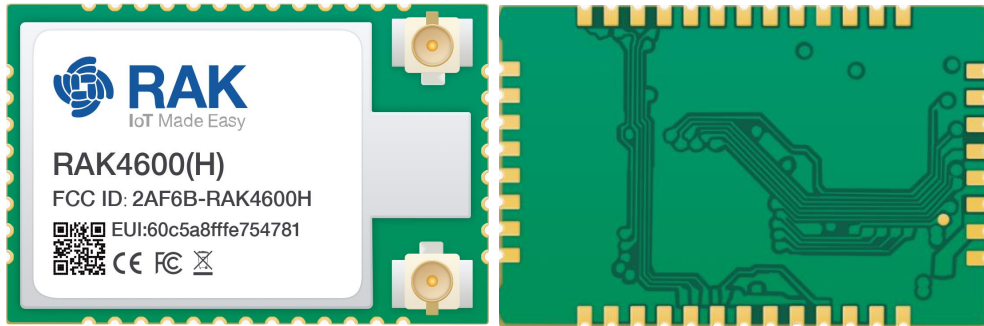
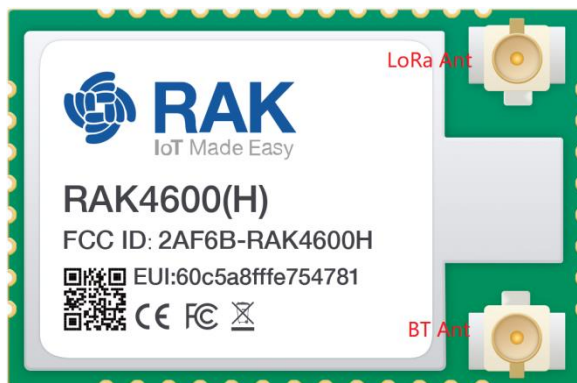

Figure 1 | RAK4600 LoRa Module

### 2.2 BT and LoRa Antenna position

RAK4600 support both BT and LoRa. The picture below shows the BT and LoRa Antenna position.



### 2.3 Block Diagram

The Block diagram below shows the external interfaces of the RAK4600 LoRa Module.

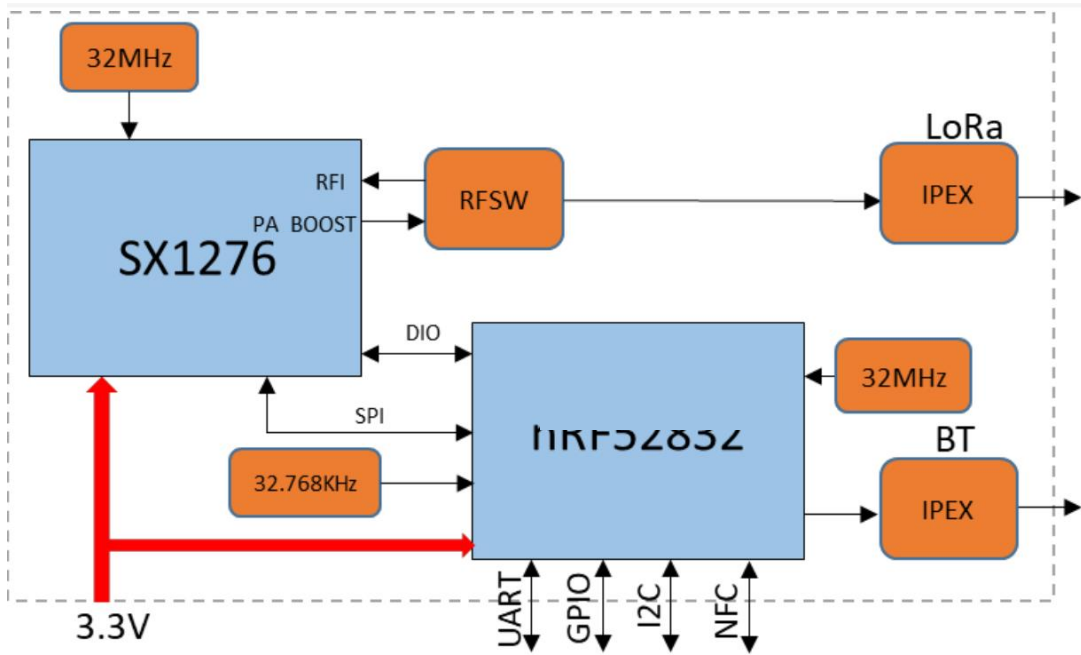

Figure 2 | Block Diagram

## 2.4 Supported LoRaWAN Bands

The RAK4600 LoRa Module supports the high LoRaWAN bands (refer to the Table 1).

Region	Frequency (MHz)
Indian	IN865
Europe	EU868
North America	US915
Australia	AU915
Korea	KR920
Asia	AS923

Table 1 | Operating Frequencies

## 2.5 Pin Definition & Pin Out

The figure below shows the pin out of the RAK4600 LoRa Module.

RAK4600 Pinout Diagram

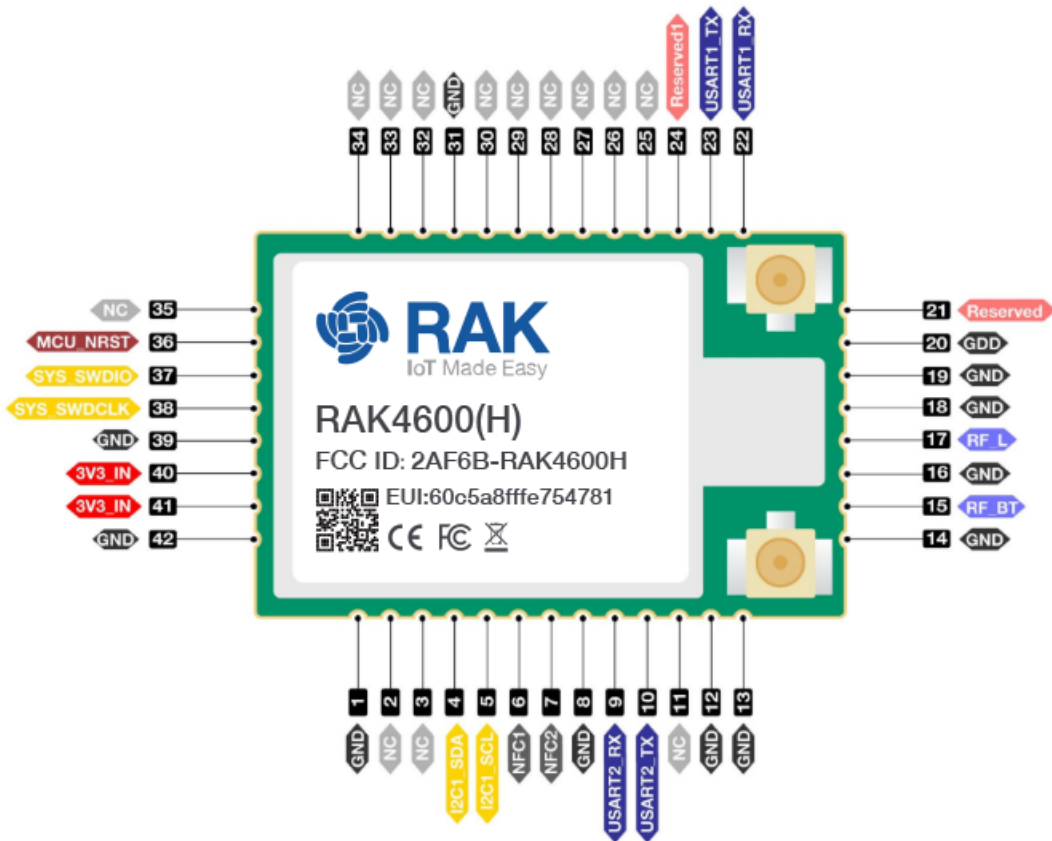

Figure 3 | Pinout

The table below shows the pin definition of the RAK4600 LoRa Module.

Pin	Name	I/O	Description
1	GND	-	Ground
2	NC	-	NC
3	NC	-	NC
4	I2C1_SDA	I/O	I2C,General purpose I/O (p0.13)
5	I2C1_SCL	I/O	I2C,General purpose I/O (p0.12)
6	NFC1	I/O	General purpose I/O、 NFC antenna connection(p0.09)
7	NFC2	I/O	General purpose I/O、 NFC antenna connection (p0.10)
8	GND	-	Ground
9	USART2_RX	I/O	USART2_RX (General purpose I/O p0.18)
10	USART2_TX	I/O	USART2_TX (General purpose I/O p0.19)

11	NC	-	NC
12	GND	I/O	Ground
13	GND	-	Ground
14	GND	-	Ground
15	RF_BT	I/O	BLE RF OUT
16	GND	-	Ground
17	RF_L	I/O	LoRa RF OUT
18	GND	-	Ground
19	GND	-	Ground
20	GDD	-	Ground
21	GPIO1/P0.14	I/O	General purpose I/O (p0.14)
22	USART1_RX	I/O	USART1_RX (General purpose I/O p0.22)
23	USART1_TX	I/O	USART1_TX (General purpose I/O p0.23)
24	GPIO2/P0.17	I/O	General purpose I/O p0.17
25	NC	-	NC
26	NC	-	NC
27	NC	-	NC
28	NC	-	NC
29	NC	-	NC
30	NC	-	NC
31	GND	-	Ground
32	NC	-	NC
33	NC	-	NC
34	NC	-	NC
35	NC	-	NC
36	MCU_Nrst	I/O	MCU reset
37	SYS_SWdIO	I/O	SYS_SWdIO
38	SYS_SWdCLK	I/O	SYS_SWdCLK
39	GND	-	Ground
40	3V3_IN	-	Input power
41	3V3_IN	-	Input power
42	GND	-	Ground

**Table 2 | Pin Definitions**

## 2.6 Power Consumption

Item	Power Consumption	Condition
Tx mode LoRa @20dBm	125mA	LoRa @ PA_BOOST &BT sleep
Tx mode LoRa @17dBm	92mA	LoRa @ PA_BOOST &BT sleep
Tx mode BT@4dBm	9mA	BT Tx mode & Lora sleep
Rx mode LoRa @37.5Kbps	17mA	LoRa @ Receive mode &BT sleep
Rx mode BT@2Mbps	11.5mA	BT Rx mode & Lora sleep
Sleep mode	2.0uA	LoRa&BT sleep

*Table 3 | Power Consumption*

## 2.7 Mechanical Dimensions

The figure below shows the mechanical dimension of the RAK4600 LoRa Module.

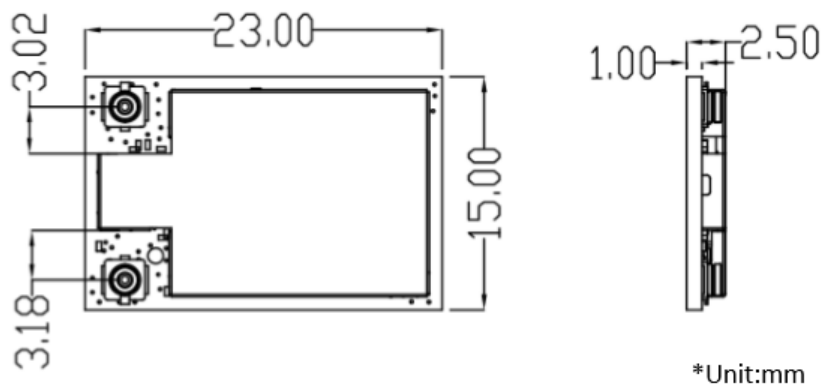



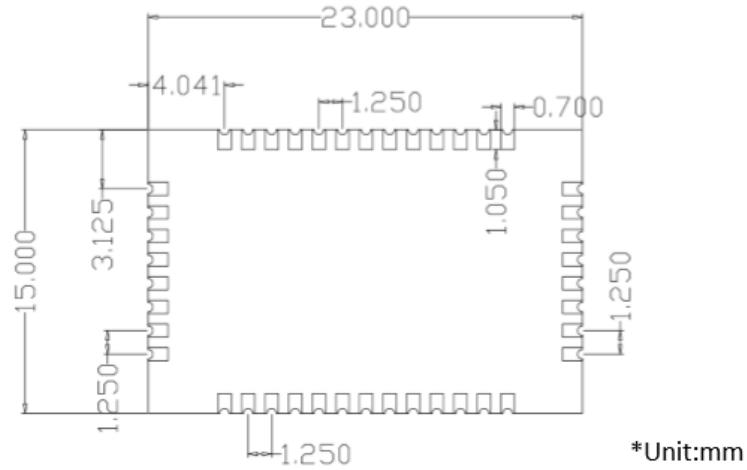

Figure 4 | Mechanical Dimensions

## 2.8 Recommended Footprint

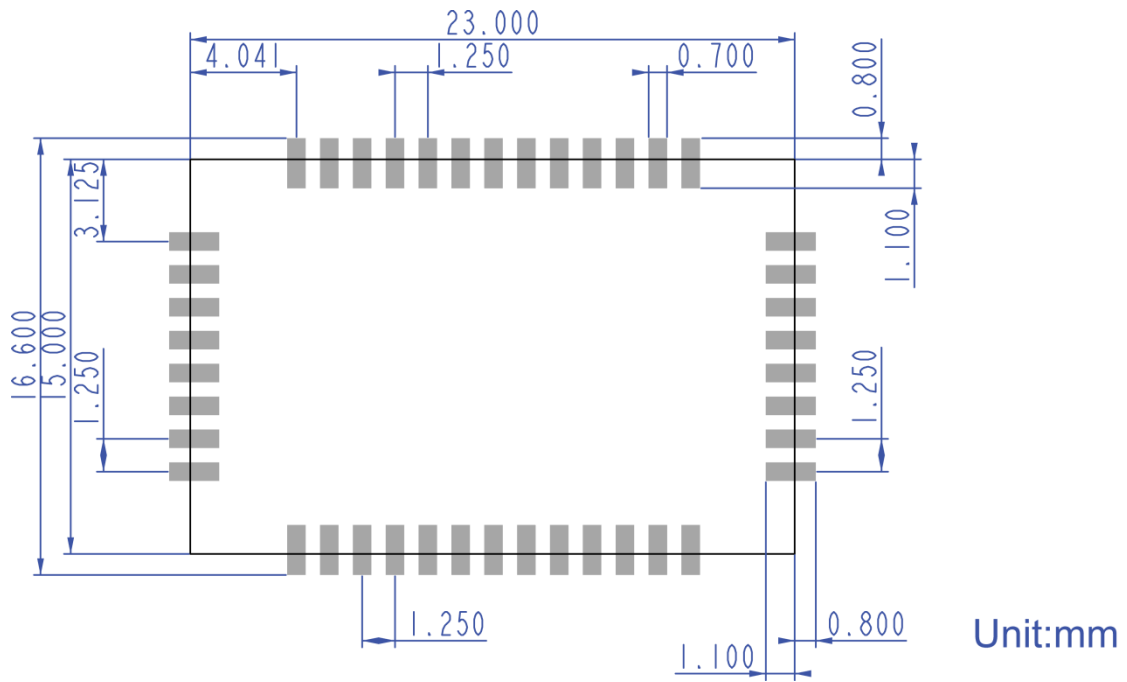
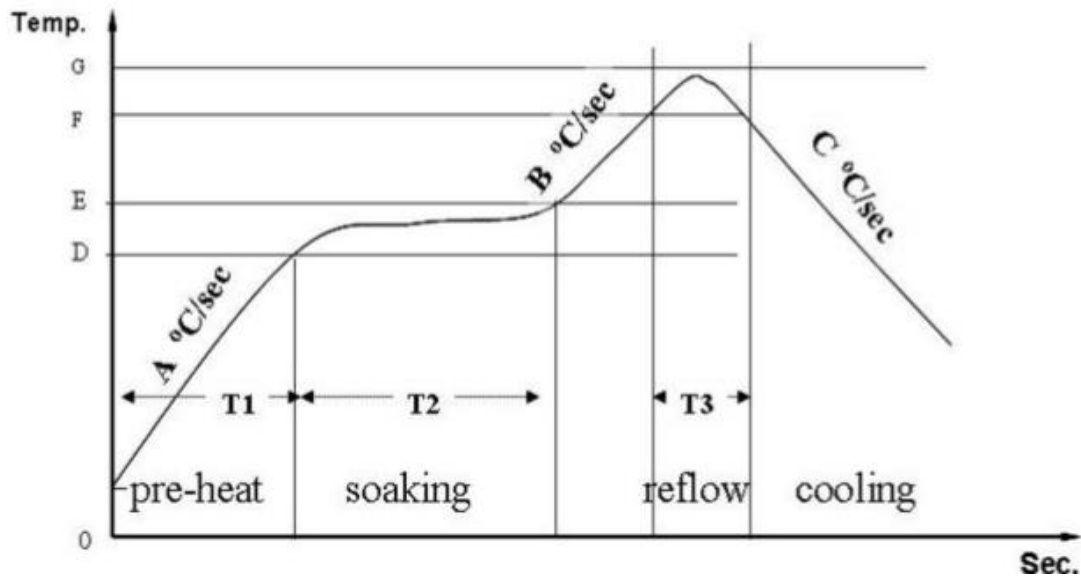

Figure 5 | Recommended Footprint

## 2.9 Recommended Reflow Profile



**Figure 6** | Recommended Reflow Profile

Standard conditions for reflow soldering:

- Pre-heating Ramp (A) (Initial temperature: 150°C): 1~2.5°C/sec;
- Soaking Time (T2) (150°C~180°C): 60sec~100sec;
- Peak Temperature (G): 230~250°C;
- Reflow Time (T3) (>220°C): 30~60 sec;
- Ramp-up Rate (B): 0~2.5°C/ sec;
- Ramp-down Rate (C): 1~3°C/ sec.

**Please contact us if you need technical support or need more information.**

**Support center:** <https://forum.rakwireless.com/>

**Start guide and software firmware download:**

<https://downloads.rakwireless.com/en/LoRa/RAK4600/>

**Email us:** [info@rakwireless.com](mailto:info@rakwireless.com)

## 2.9 FCC Caution

This device complies with Part 15 of the FCC Rules. Operation is subject to the following two conditions: (1) this device may not cause harmful interference, and (2) this device must accept any interference received, including interference that may cause undesired operation.

Changes or modifications to this unit not expressly approved by the party responsible for compliance could void the user's authority to operate the equipment.

NOTE: This equipment has been tested and found to comply with the limits for a Class B digital device, pursuant to Part 15 of the FCC Rules. These limits are designed to provide reasonable protection against harmful interference in a residential installation. This equipment generates, uses and can radiate radio frequency energy and, if not installed and used in accordance with the instructions, may cause harmful interference to radio communications. However, there is no guarantee that interference will not occur in a particular installation. If this equipment does cause harmful interference to radio or television reception, which can be determined by turning the equipment off and on, the user is encouraged to try to correct the interference by one or more of the following measures:

- Reorient or relocate the receiving antenna.
- Increase the separation between the equipment and receiver.
- Connect the equipment into an outlet on a circuit different from that to which the receiver is connected.
- Consult the dealer or an experienced radio/TV technician for help.

This device and its antenna(s) must not be co-located or operation in conjunction with any other antenna or transmitter.

### Radiation Exposure Statement

To maintain compliance with FCC's RF Exposure guidelines, This equipment should be installed and operated with minimum distance of 20cm from your body.

**Integration instructions for host product manufacturers according to KDB 996369 D03 OEM Manual v01**

**2.2 List of applicable FCC rules[and ISED Radio Standards Specifications]**

CFR 47 FCC PART 15 SUBPART C has been investigated. It is applicable to the modular.

**2.3 Specific operational use conditions**

This module is stand-alone modular. If the end product will involve the Multiple simultaneously transmitting condition or different operational conditions for a stand-alone modular transmitter in a host, host manufacturer have to consult with module manufacturer for the installation method in end system.

**2.4 Limited module procedures**

Not applicable

**2.5 Trace antenna designs**

Not applicable

**2.6 RF exposure considerations**

This equipment should be installed and operated with minimum distance of 20cm from your body

**2.7 Antennas**

This radio transmitter FCC ID: 2AF6B-RAK4600H has been approved by Federal Communications Commission to operate with the antenna types listed below, with the maximum permissible gain indicated. Antenna types not included in this list that have a gain greater than the maximum gain indicated for any type listed are strictly prohibited for use with this device.

Antenna No.	Operate frequency band	Antenna Type	Maximum antenna gain
Antenna 1	902 GHz – 928 GHz	External Antenna	3.00 dBi
Antenna 2	2402 MHz – 2480 MHz	External Antenna	3.00 dBi

**2.8 Label and compliance information**

The final end product must be labeled in a visible area with the following" Contains FCC ID: 2AF6B-RAK4600H

**2.9 Information on test modes and additional testing requirements**

Host manufacturer is strongly recommended to confirm compliance with FCC requirements for the transmitter when the module is installed in the host...

**2.10 Additional testing, Part 15 Subpart B/ Canadian CAN ICES-003 (B) disclaimer**

Host manufacturer is responsible for compliance of the host system with module installed with all other applicable requirements for the system such as Part 15 B \_\_\_\_\_

### 3. Revision History

Revision	Description	Date
1.0	Initial version	2019-05-27
1.1	Revision of parameters	2019-10-24
1.2	Revision of power consumption	2019-11-22

### 4. Document Summary

Prepared by	Checked by	Approved by
Hairui	Penn & Vladislav	



**About RAKwireless:**

RAKwireless is the pioneer in providing innovative and diverse cellular and LoRa connectivity solutions for IoT edge devices. It's easy and modular design can be used in different IoT applications and accelerate time-to-market.

www. [rakwireless.com](http://www.rakwireless.com) For more information, please visit RAKwireless website at [www.rakwireless.com](http://www.rakwireless.com).