

RAK4200(H) LoRa Module

WisDuo-LoRa Series

Version V1.1 | October 2019

www.RAKwireless.com

Visit our website for more document.

10 PAGES

Table of Contents

1. Overview	3
1.1 Introduction.....	3
1.2 Main Features	3
2. RAK4200(H) LoRa Module	4
2.1 Overview.....	4
2.2 Pin Definition & Pin Out.....	4
2.3 Mechanical Dimensions.....	6
2.4 Recommended Footprint.....	7
2.5 Recommended Reflow Profile.....	7
3. Warning	9
4. Revision History	10
5. Document Summary	10

1. Overview

1.1 Introduction

RAK4200(H) LoRa Module includes an STM32L071 MCU and an SX1276 LoRa chip. It has Ultra-Low Power Consumption of 1.5uA in sleep mode and high LoRa output power up to 13.92dBm max in work mode.

The module complies with LoRaWAN 1.0.2 protocols. It also supports Lora Point to Point communications. The module is suitable for various applications that require long range data acquisition and low power consumption.

1.2 Main Features

- LoRa module for Smart City, Smart Agriculture, Smart Industry
- Compact Form Factor: 15 x 15.5 x 2.5 mm
- 20 Pin Stamp Pad for PCB SMT mounting
- I/O ports: UART/I2C/GPIO
- Temperature range: -40°C to +85°C
- Supply voltage: 2.0 ~ 3.6V
- Frequency range: 902.3-914.9 MHz, 903~927.5 MHz
- IEEE 802.15.4g, Wireless M-Bus and Proprietary Systems
- Low-Power Wireless Systems
- Ultra-Low Power Consumption 1.5uA in sleep mode
- Core: ARM 32-bit Cortex – M0+ with MPU
- Up to 192KB flash memory with ECC
- 20KB RAM
- 6KB of data EEPROM with ECC

2. RAK4200(H) LoRa Module

2.1 Overview

The figure below shows the top view of the RAK4200(H) LoRa Module. The dimensions of the Module are 15 x 15.5 x 2.5 mm.



Figure 1 | RAK4200(H) LoRa Module

2.2 Pin Definition & Pin Out

The figure below shows the pinout of the RAK4200(H) LoRa Module.

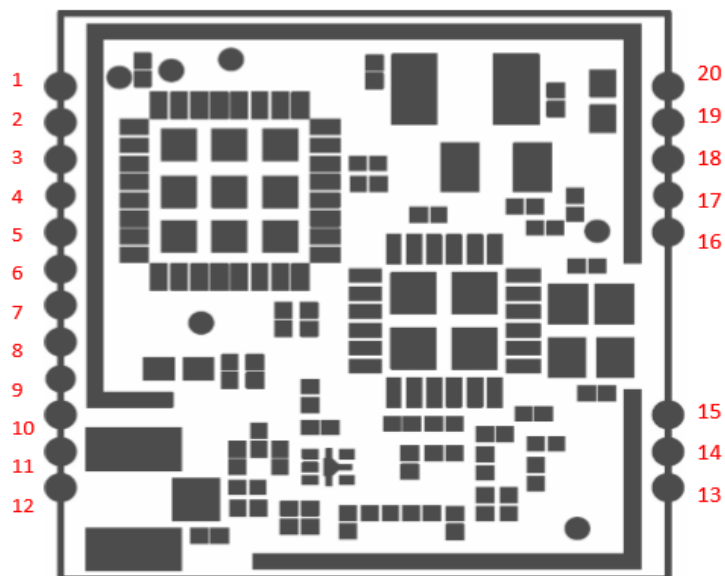

Figure 2 | Pinout

The table below shows the pin definition of the RAK4200(H) LoRa Module.

Pin	Name	I/O	Description
1	UART2_RX	I	Main UART (STM32L071K8 PA10)
2	UART2_TX	O	Main UART (STM32L071K8 PA9)
3	UART2_DE	I/O	GPIO (STM32L071K8 PA12)
4	UART1_TX	I/O	General GPIO or UART(Reserved) (STM32L051K8 PA2)
5	UART1_RX	I/O	General GPIO or UART(Reserved) (STM32L051K8 PA3)
6	UART1_DE	I/O	General GPIO or UART(Reserved) (STM32L051K8 PA1)
7	SWDIO	I/O	Programming (STM32L051K8 PA13)
8	SWCLK	I/O	Programming (STM32L051K8 PA14)
9	I2C_SCL	I/O	I2C interface (STM32L051K8 PB6)
10	I2C_SDA	I/O	I2C interface (STM32L051K8 PB7)
11	GND	-	Ground
12	RF	I/O	RF port (reserved), default RF out by IPEX
13	GND	-	Ground
14	GND	-	Ground
15	SPI_CLK	I/O	Reserved PA5
16	SPI_MISO	I/O	Reserved PA6
17	SPI_MOSI	I/O	Reserved PA7
18	MCU_NRST	I/O	MCU reset (STM32L051K8 NRST)
19	GND	-	Ground
20	VDD	-	DC3V3

Table 1 | Pin Definitions

2.3 Mechanical Dimensions

The figure below shows the mechanical dimension of the RAK4200(H) LoRa Module.

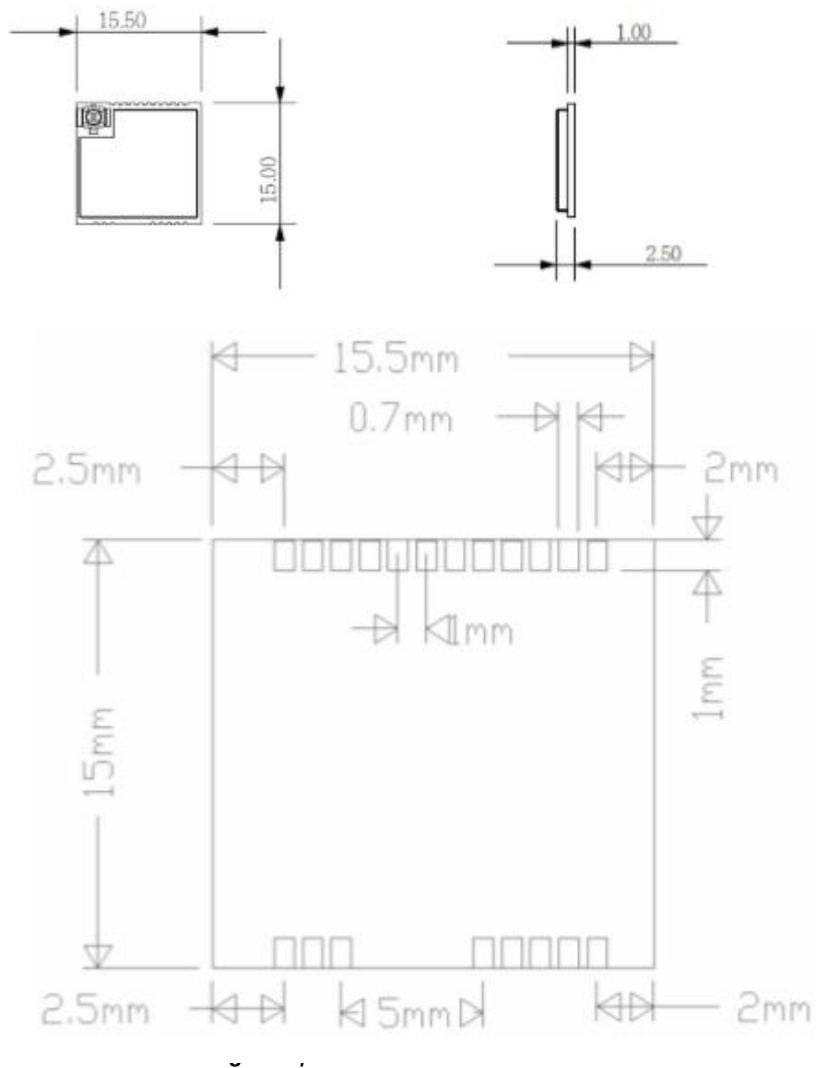

2.4 Recommended Footprint

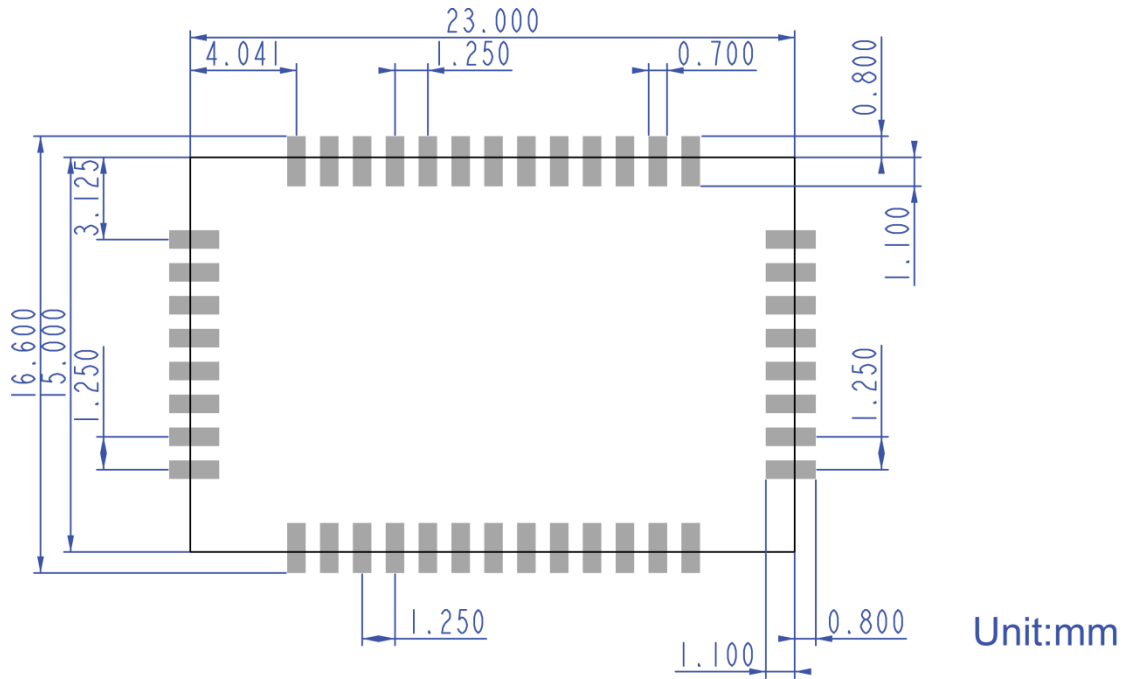

Figure 5 | Recommended Footprint

2.5 Recommended Reflow Profile

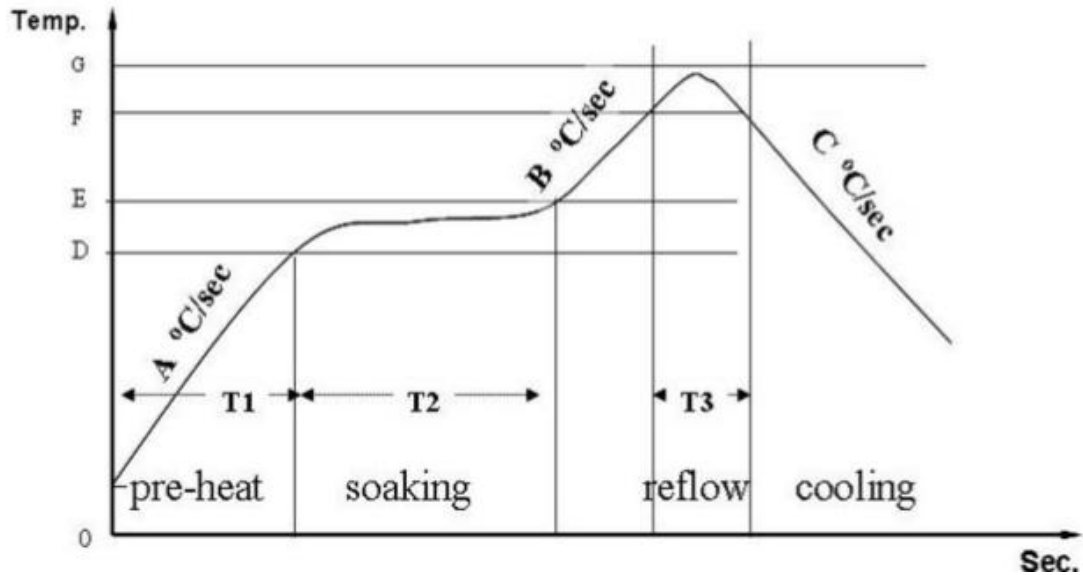

Figure 6 | Recommended Reflow Profile

Standard conditions for reflow soldering:

- Pre-heating Ramp (A) (Initial temperature: 150°C): 1~2.5°C/sec;

- Soaking Time (T2) (150°C~180°C): 60sec~100sec;
- Peak Temperature (G): 230~250°C;
- Reflow Time (T3) (>220°C): 30~60 sec;
- Ramp-up Rate (B): 0~2.5°C/ sec;
- Ramp-down Rate (C): 1~3°C/ sec.

Please contact us if you need technical support or need more information.

Support center: <https://forum.rakwireless.com/>

Email us: info@rakwireless.com

3. Warning

FCC Warning:

This device complies with part 15 of the FCC Rules. Operation is subject to the following two conditions.

- (1) This device may not cause harmful interference;
- (2) This device must accept any interference received, including interference that may cause undesired operation.

Any Changes or modifications not expressly approved by the party responsible for compliance could void the user's authority to operate the equipment.

INTEGRATION INSTRUCTIONS

1. This module has been tested and found to comply with the FCC Part15.247 for Modular Approval.
2. This Modular Approval is limited to OEM installation for mobile and fixed applications only. The antenna installation and operating configurations of this transmitter, including any applicable source-based time- averaging duty factor, antenna gain and cable loss must satisfy MPE categorical Exclusion Requirements of 2.1091. This modular should be installed and operated with minimum distance 20 cm between the radiator& your body.
3. The U.FL connector antenna has been approved for the modular. The maximum antenna gain is 3dBi. For situations where the host manufacturer is responsible for an external connector, the integration instructions shall inform the installer that a unique antenna connector must be used on the Part 15 authorized transmitters used in the host product.
4. When the module is installed in the host device, the FCC ID label must be visible through a window on the final device or it must be visible when an access panel, door or cover is easily removed. If not, a second label must be placed on the outside of the final device that contains the following text: — Contains FCC ID: 2AF6B-RAK4200H.
5. The Shenzhen Rakwireless Technology Co., Ltd. uses various test mode programs for test set up which operate separate from production firmware. Host integrators should contact Shenzhen Rakwireless Technology Co., Ltd. for assistance with test modes needed for module/host compliance test requirements.
6. The Shenzhen Rakwireless Technology Co., Ltd. modular transmitter is only FCC authorized for the FCC Part15.247 listed on the grant, and that the host product manufacturer is responsible for compliance to any other FCC rules that apply to the host not covered by the modular transmitter grant of certification. If the grantee markets their product as being Part 15 Subpart B compliant (when it also contains unintentional-radiator digital circuitry), then the grantee shall provide a notice stating that the final host product still requires Part 15 Subpart B compliance testing with the modular transmitter installed.

4. Revision History

Revision	Description	Date
1.0	Initial version	2019-05-24
1.1	Revision of parameters	2019-10-24

5. Document Summary

Prepared by	Checked by	Approved by
Hairui	Penn & Vladislav	



About RAKwireless:

RAKwireless is the pioneer in providing innovative and diverse cellular and LoRa connectivity solutions for IoT edge devices. It's easy and modular design can be used in different IoT applications and accelerate time-to-market.

For more information, please visit RAKwireless website at www.rakwireless.com.