



Prüfbericht-Nr.: <i>Test report no.:</i>	CN21MROF 001	Auftrags-Nr.: <i>Order no.:</i>	168320408	Seite 1 von 29 <i>Page 1 of 29</i>	
Kunden-Referenz-Nr.: <i>Client reference no.:</i>	N/A	Auftragsdatum: <i>Order date:</i>	2021-06-01		
Auftraggeber: <i>Client:</i>	Shenzhen RAKwireless Technology Co.,Ltd. Room 506, Building B, New Compark, Pingshan First Road, Taoyuan Street, Nanshan District, Shenzhen, Guangdong, China				
Prüfgegenstand: <i>Test item:</i>	WisDuo LPWAN Module				
Bezeichnung / Typ-Nr.: <i>Identification / Type no.:</i>	RAK3172 (Trademark: RAK)				
Auftrags-Inhalt: <i>Order content:</i>	FCC and IC approval				
Prüfgrundlage: <i>Test specification:</i>	CFR47 FCC Part 15: Subpart C Section 15.247 CFR47 FCC Part 15: Subpart C Section 15.207 CFR47 FCC Part 15: Subpart C Section 15.209 CFR47 FCC Part 2: Section 2.1093	RSS-247 Issue 2 February 2017 RSS-Gen Issue 5 February 2021 RSS-102 Issue 5 February 2021			
Wareneingangsdatum: <i>Date of sample receipt:</i>	2021-06-01	Please refer to photo documents			
Prüfmuster-Nr.: <i>Test sample no.:</i>	A003054687-008, A003054687-013, A003054687-014				
Prüfzeitraum: <i>Testing period:</i>	2021-06-18 - 2021-06-24				
Ort der Prüfung: <i>Place of testing:</i>	TÜV Rheinland (Shenzhen) Co., Ltd.				
Prüflaboratorium: <i>Testing laboratory:</i>	TÜV Rheinland (Shenzhen) Co., Ltd.				
Prüfergebnis*: <i>Test result*:</i>	Pass				
geprüft von: <i>tested by:</i>		genehmigt von: <i>authorized by:</i>			
Datum: <i>Date:</i> 2021-10-18	<small>Signed by: Alex Lan</small>	Ausstellungsdatum: <i>Issue date:</i> 2021-10-18	<small>Signed by: Winnie Hou</small>		
Stellung / Position	Senior Project Engineer	Stellung / Position	Technical Certifier		
Sonstiges / Other:	FCC ID: 2AF6B-RAK3172 IC: 25908-RAK3172, HVIN: RAK3172				
Zustand des Prüfgegenstandes bei Anlieferung: <i>Condition of the test item at delivery:</i>	Prüfmuster vollständig und unbeschädigt <i>Test item complete and undamaged:</i>				
Legend:	1 = sehr gut P(ass) = entspricht o.g. Prüfgrundlage(n) 1 = very good P(ass) = passed a.m. test specifications(s)	2 = gut F(ail) = entspricht nicht o.g. Prüfgrundlage(n) 2 = good F(ail) = failed a.m. test specifications(s)	3 = befriedigend F(ail) = entspricht nicht o.g. Prüfgrundlage(n) 3 = satisfactory F(ail) = failed a.m. test specifications(s)	4 = ausreichend N/A = nicht anwendbar 4 = sufficient N/A = not applicable	5 = mangelhaft N/T = nicht getestet 5 = poor N/T = not tested
Dieser Prüfbericht bezieht sich nur auf das o.g. Prüfmuster und darf ohne Genehmigung der Prüfstelle nicht auszugsweise vervielfältigt werden. Dieser Bericht berechtigt nicht zur Verwendung eines Prüfzeichens. <i>This test report only relates to the a. m. test sample. Without permission of the test center this test report is not permitted to be duplicated in extracts. This test report does not entitle to carry any test mark.</i>					

Test Summary

5.1.1 ANTENNA REQUIREMENT*RESULT: Pass***5.1.2 MAXIMUM PEAK CONDUCTED OUTPUT POWER***RESULT: Pass***5.1.3 CONDUCTED POWER SPECTRAL DENSITY***RESULT: Pass***5.1.4 6dB BANDWIDTH***RESULT: Pass***5.1.5 20dB BANDWIDTH***RESULT: Pass***5.1.6 99% BANDWIDTH***RESULT: Pass***5.1.7 CONDUCTED SPURIOUS EMISSIONS MEASURED IN 100 KHz BANDWIDTH***RESULT: Pass***5.1.8 RADIATED SPURIOUS EMISSION***RESULT: Pass***5.1.9 CARRIER FREQUENCY SEPARATION***RESULT: Pass***5.1.10 NUMBER OF HOPPING FREQUENCY***RESULT: Pass***5.1.11 TIME OF OCCUPANCY***RESULT: Pass***5.1.12 CONDUCTED EMISSION ON AC MAINS***RESULT: Pass***6.1.1 ELECTROMAGNETIC FIELDS***RESULT: Pass*

Contents

1	GENERAL REMARKS	5
1.1	COMPLEMENTARY MATERIALS	5
2	TEST SITES.....	6
2.1	TEST FACILITIES.....	6
2.2	LIST OF TEST AND MEASUREMENT INSTRUMENTS	6
2.3	TRACEABILITY.....	7
2.4	CALIBRATION.....	7
2.5	MEASUREMENT UNCERTAINTY	7
2.6	LOCATION OF ORIGINAL DATA	8
2.7	STATUS OF FACILITY USED FOR TESTING.....	8
3	GENERAL PRODUCT INFORMATION.....	9
3.1	PRODUCT FUNCTION AND INTENDED USE.....	9
3.2	RATINGS AND SYSTEM DETAILS	9
3.3	INDEPENDENT OPERATION MODES	11
3.4	NOISE GENERATING AND NOISE SUPPRESSING PARTS.....	11
3.5	SUBMITTED DOCUMENTS.....	11
4	TEST SET-UP AND OPERATION MODES	12
4.1	PRINCIPLE OF CONFIGURATION SELECTION.....	12
4.2	TEST OPERATION AND TEST SOFTWARE.....	12
4.3	SPECIAL ACCESSORIES AND AUXILIARY EQUIPMENT.....	12
4.4	COUNTERMEASURES TO ACHIEVE EMC COMPLIANCE.....	12
4.5	TEST SETUP DIAGRAM	13
5	TEST RESULTS.....	15
5.1	TRANSMITTER REQUIREMENT & TEST SUITES.....	15
5.1.1	<i>Antenna Requirement.....</i>	<i>15</i>
5.1.2	<i>Maximum Peak Conducted Output Power.....</i>	<i>16</i>
5.1.3	<i>Conducted Power Spectral Density.....</i>	<i>17</i>
5.1.4	<i>6dB Bandwidth.....</i>	<i>18</i>
5.1.5	<i>20dB Bandwidth.....</i>	<i>19</i>
5.1.6	<i>99% Bandwidth</i>	<i>20</i>
5.1.7	<i>Conducted Spurious Emissions Measured in 100 kHz Bandwidth</i>	<i>21</i>
5.1.8	<i>Radiated Spurious Emission.....</i>	<i>22</i>
5.1.9	<i>Carrier Frequency Separation.....</i>	<i>23</i>
5.1.10	<i>Number of Hopping Frequency.....</i>	<i>24</i>
5.1.11	<i>Time of Occupancy.....</i>	<i>25</i>
5.1.12	<i>Conducted Emission on AC Mains.....</i>	<i>26</i>
6	SAFETY HUMAN EXPOSURE	27
6.1	RADIO FREQUENCY EXPOSURE COMPLIANCE.....	27
6.1.1	<i>Electromagnetic Fields</i>	<i>27</i>

7 **PHOTOGRAPHS OF THE TEST SET-UP.....29**

8 **LIST OF TABLES29**

1 General Remarks

1.1 Complementary Materials

All attachments are integral parts of this test report. This applies especially to the following appendix:

Appendix A: Photographs of the Test Set-up

Appendix B: Test Results.

2 Test Sites

2.1 Test Facilities

TÜV Rheinland (Shenzhen) Co., Ltd.

362 Huanguan Road Middle Longhua District, Shenzhen 518110 People's Republic of China

FCC Registration No.: 694916

ISED wireless device testing laboratory: 25069

2.2 List of Test and Measurement Instruments

Table 1: List of Test and Measurement Equipment

TÜV Rheinland (Shenzhen) Co., Ltd.

Radio Spectrum Testing (TS8997)				
Equipment	Manufacturer	Model	Serial No.	Cal. until
Signal Analyzer	R&S	FSV 40	101441	2022-08-09
OSP	R&S	OSP 150	101017	2021-12-10
Control PC	DELL	OptiPlex 7050	FTJZ9P2	N/A
Test Software	R&S	WMS32 (V11.00.00)	N/A	N/A
Power Meter	R&S	NRP2	107105	2021-12-10
Power Sensor	R&S	NRP-Z81	105677	2022-08-09
Shielding Room 8#	Albatross	SR8	APC17151-SR8	2024-06-22
Unwanted Emission Testing (TS9975)				
Equipment	Manufacturer	Model	Serial No.	Cal. until
EMI Test Receiver	R&S	ESR 7	102021	2022-08-10
Signal Analyzer	R&S	FSV 40	101439	2022-08-09
System Controller Interface	R&S	SCI-100	S10010038	N/A
Filterbank	R&S	Wlan	100759	2022-08-09
OSP	R&S	OSP 120	102040	N/A
Pre-amplifier	R&S	SCU08F1	08320031	2022-08-09
Amplifier	R&S	SCU-18F	180070	2022-08-09
Amplifier	R&S	SCU40A	100475	2022-08-09
Trilog Broadband Antenna (30 MHz - 7 GHz)	Schwarzbeck	VULB 9162	193	2022-08-08
Double-Ridged Antenna (1 -18 GHz)	ETS-LINDGREN	3117	00218717	2022-08-08
Wideband Ridged Horn Antenna (18-40 GHz)	Steatite	QMS-00880	19067	2022-08-08
Active Loop Antenna	Schwarzbeck	FMZB 1513	302	2022-09-13

Test software	R&S	EMC32 (V10.60.10)	N/A	N/A
Control PC	Dell	OptiPlex 7050	36NV9P2	N/A
3m Semi-Anechoic Chamber	Albatross	SAC-3m	APC17151-SAC	2024-06-22
Conducted Emission on AC Mains				
Equipment	Manufacturer	Model No.	Serial No.	Cali. until
EMI Test Receiver	R&S	ESR3	102680	2022-04-25
Artificial Mains Network	R&S	ENV216	101445	2022-04-25
EMC32 test software	R&S	EMC32(Ver.10.50.00)	N/A	N/A

2.3 Traceability

All measurement equipment calibrations are traceable to NIM (National Institute of Metrology) or where calibration is performed in other countries, to equivalent nationally recognized standards organizations.

2.4 Calibration

Equipment requiring calibration is calibrated periodically by the manufacturer or according to manufacturer's specifications. Additionally all equipment is verified for proper performance on a regular basis using in house standards or comparisons.

2.5 Measurement Uncertainty

The estimated combined standard uncertainty for radiated emissions and conducted emissions measurements as below table.

Parameter	Uncertainty
Radio Frequency	$\pm 1 \times 10^{-7}$
RF Power (conducted)	± 2.5 dB
Radiated Emission of Transmitter, valid up to 26.5 GHz	± 6 dB
Radiated Emission of Receiver, valid up to 26.5 GHz	± 6 dB
Conducted Emission, (9kHz to 150kHz)/(150kHz to 30MHz)	± 3.70 dB / ± 3.30 dB
Radiated Emission (3m SAC), 30MHz to 1000MHz	± 4.52 dB
Radiated Emission (3m SAC), above 1000MHz	± 4.37 dB
Temperature	± 1 °C
Humidity	± 5 %
Voltage (DC)	± 1 %
Voltage (AC, <10kHz)	± 2 %

2.6 Location of Original Data

The original copies of all test data taken during actual testing were attached at Appendix A & B of this report and delivered to the applicant. A copy has been retained in the TÜV Rheinland (Shenzhen) Co., Ltd. file for certification follow-up purposes.

2.7 Status of Facility Used for Testing

The TÜV Rheinland (Shenzhen) Co., Ltd. Test facility located at 362 Huanguan Road Middle Longhua District, Shenzhen 518110 People's Republic of China is listed on the US Federal Communications Commission list of facilities approved to perform measurements.

3 General Product Information

3.1 Product Function and Intended Use

The EUT is a WisDuo LPWAN Module which supports Lora technology.

This product has two construction, one has an additional baseboard and other doesn't have, the baseboard is the extension of I/O.

Data Rate	Configuration	Indicative physical bit rate [bit/sec]
0	LoRa Modulation: SF10 / Bandwidth 125 kHz	980
1	LoRa Modulation: SF9 / Bandwidth 125 kHz	1760
2	LoRa Modulation: SF8 / Bandwidth 125 kHz	3125
3	LoRa Modulation: SF7 / Bandwidth 125 kHz	5470
4	LoRa Modulation: SF8 / Bandwidth 500 kHz	12500

For details refer to the User Manual, Technical Description and Circuit Diagram.

3.2 Ratings and System Details

Table 2: Technical Specification of EUT

General Information of EUT	Value
Kind of Equipment	WisDuo LPWAN Module
Type Designation	RAK3172
Trademark	RAK
FCC ID	2AF6B-RAK3172
IC	25908-RAK3172
HVIN	RAK3172
Operating Voltage	2.0VDC to 3.6VDC (Supplied by socket of PCB board)
Testing Voltage	DC 5V Via USB port
Antenna Type	Dipole Antenna (When connecting to the module, the antenna need to transfer to an IPEX connector)
Antenna Gain	2.3 dBi (Max)
Technical Specification of Lora DTS	
Operating Frequency	903 – 914.2MHz
Type of Modulation	Lora
Data Rate	LoRa: SF8 / DR4
Channel Number	8 channels (Upstream)
Channel Separation	1.6 MHz
Occupied Bandwidth	500 KHz
Technical Specification of Lora FHSS	
Frequency Range	902.3 – 914.9MHz
Type of Modulation	Lora
Data Rate	LoRa: SF7 to SF10 / DR0 to DR3
Channel Number	64 channels (Upstream)
Channel Separation	200 KHz
Occupied Bandwidth	125 KHz

Table 3: RF Channel and Frequency of Lora FHSS

RF Channel	Frequency (MHz)	RF Channel	Frequency (MHz)	RF Channel	Frequency (MHz)	RF Channel	Frequency (MHz)
0	902.3	16	905.5	32	908.7	48	911.9
1	902.5	17	905.7	33	908.9	49	912.1
2	902.7	18	905.9	34	909.1	50	912.3
3	902.9	19	906.1	35	909.3	51	912.5
4	903.1	20	906.3	36	909.5	52	912.7
5	903.3	21	906.5	37	909.7	53	912.9
6	903.5	22	906.7	38	909.9	54	913.1
7	903.7	23	906.9	39	910.1	55	913.3
8	903.9	24	907.1	40	910.3	56	913.5
9	904.1	25	907.3	41	910.5	57	913.7
10	904.3	26	907.5	42	910.7	58	913.9
11	904.5	27	907.7	43	910.9	59	914.1
12	904.7	28	907.9	44	911.1	60	914.3
13	904.9	29	908.1	45	911.3	61	914.5
14	905.1	30	908.3	46	911.5	62	914.7
15	905.3	31	908.5	47	911.7	63	914.9

Table 4: RF Channel and Frequency of Lora DTS

RF Channel	Frequency (MHz)	RF Channel	Frequency (MHz)	RF Channel	Frequency (MHz)	RF Channel	Frequency (MHz)
64	903.0	66	906.2	68	909.4	70	912.6
65	904.6	67	907.8	69	911.0	71	914.2

3.3 Independent Operation Modes

The basic operation modes are:

- A. On, Lora transmitting mode (FHSS)
 - 1) Low Channel
 - 2) Middle Channel
 - 3) High Channel
- B. On, Lora transmitting mode (DTS)
 - 1) Low Channel
 - 2) Middle Channel
 - 3) High Channel
- C. On, Transmitting on Hopping channel
- D. Off

3.4 Noise Generating and Noise Suppressing Parts

Refer to Circuit Diagram for further details.

3.5 Submitted Documents

- ID Label and Location Info

- User Manual

4 Test Set-up and Operation Modes

4.1 Principle of Configuration Selection

Radio Spectrum: The equipment under test (EUT) was configured at its highest power output in order to measure its highest possible radiation and conducted level. The test modes were adapted accordingly in reference to the instructions for use.

Emission: The equipment under test (EUT) was configured to measure its highest possible radiation level. The test modes were adapted accordingly in reference to the instructions for use.

4.2 Test Operation and Test Software

Test operation refers to test setup in chapter 5. All tests were performed according to the procedures in ANSI C63.10: 2013 and ANSI C63.4: 2014.

According to clause 3.1, all tests were performed on model RAK3172 with baseboard in this report.

4.3 Special Accessories and Auxiliary Equipment

Table 5: Auxiliary Equipment Used during Test

Description	Manufacturer	Model	S/N	Rating
PC	Lenovo	ThinkPad T480	N/A	PC
PC adapter	Lenovo	ADLX65YDC3A	01FR030	PC adapter

4.4 Countermeasures to Achieve EMC Compliance

The test sample which has been tested contained the noise suppression parts as described in the Technical Construction File (TCF).

No additional measures were employed to achieve compliance.

4.5 Test Setup Diagram

Diagram of Measurement Configuration for Radiation Test (Below 30MHz)

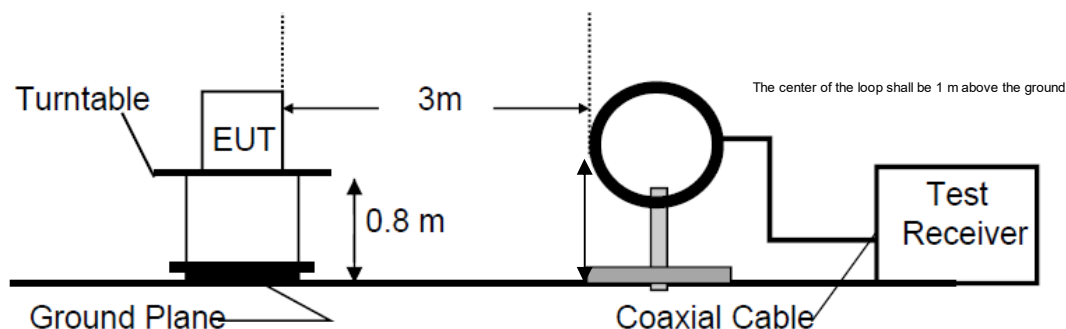

Diagram of Measurement Configuration for Radiation Test (Below 1GHz)

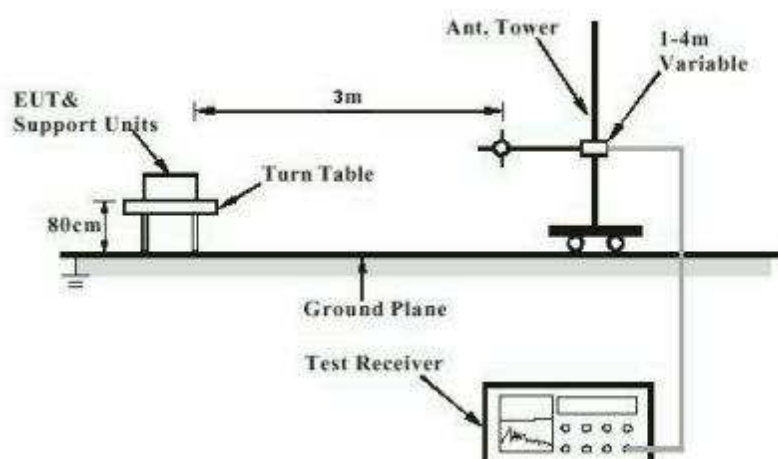

Diagram of Measurement Configuration for Radiation Test (Above 1GHz)

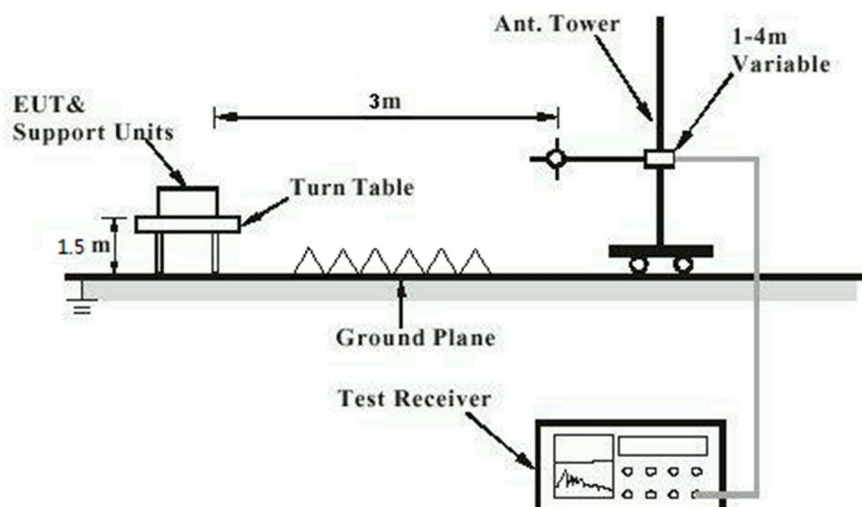

Diagram of Measurement Configuration for Mains Conduction Measurement

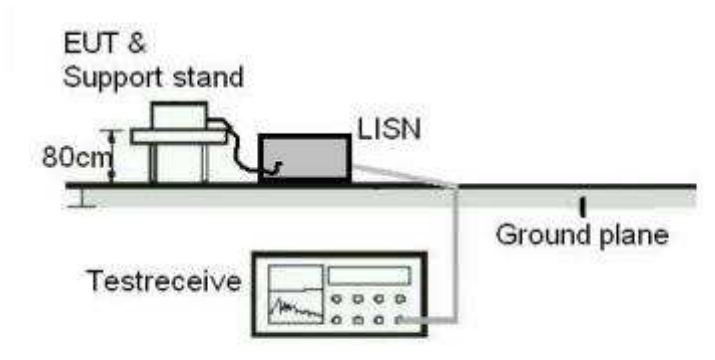
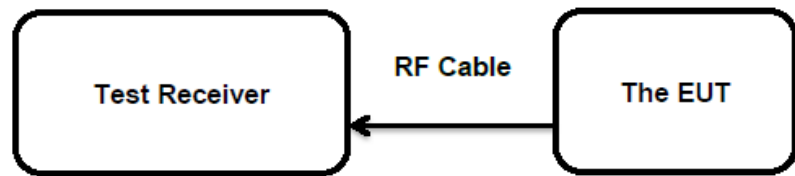

Diagram of Measurement Configuration for Conducted Transmitter Measurement



5 Test Results

5.1 Transmitter Requirement & Test Suites

5.1.1 Antenna Requirement

RESULT:

Pass

Test Specification

Test standard : FCC Part 15.247(b)(4) and Part 15.203
RSS-Gen Clause 6.8

According to the manufacturer declared, the EUT has a Dipole Antenna, the directional gain of antenna is 2.3 dBi, and the antenna connector is designed with permanent attachment and no consideration of replacement. Therefore the EUT is considered sufficient to comply with the provision.

Refer to EUT Photo for further details.

5.1.2 Maximum Peak Conducted Output Power

RESULT:
Pass
Test Specification

Test standard	:	FCC Part 15.247(b)(2)&(3) RSS-247 Clause 5.4(a)&(d)
Basic standard	:	ANSI C63.10: 2013 Not more than 1Watt(30dBm) for DTS in the band 902-928MHz and 2400-2483.5MHz
Limits	:	Not more than 1Watt(30dBm) for FHSS with at least 50 hopping channels in the band 902-928MHz
Kind of test site	:	Shielded Room

Test Setup

Date of testing	:	2021-06-21 -2021-06-24
Input voltage	:	DC 5V Via USB port
Operation mode	:	A, B
Test channel	:	Low / Middle / High
Ambient temperature	:	25 °C
Relative humidity	:	56 %
Atmospheric pressure	:	101 kPa

Note: This test was carried out on right earphone only.

Table 6: Test Result of Maximum Peak Conducted Output Power, Lora FHSS

Test Mode	Test Channel (MHz)	Measured Peak Power		Limit (W)
		(dBm)	(W)	
Lora FHSS	902.3	20.56	0.1138	< 0.125
	908.5	20.62	0.1153	
	914.9	20.60	0.1148	
Max. Measured Value		20.62	0.1153	

Table 7: Test Result of Maximum Peak Conducted Output Power, Lora DTS

Test Mode	Test Channel (MHz)	Measured Peak Power		Limit (W)
		(dBm)	(W)	
Lora DTS	903.0	24.04	0.2535	< 1.0
	907.8	24.08	0.2559	
	914.2	24.05	0.2541	
Max. Measured Value		24.08	0.2559	

Note:

- 1) The cable loss is taken into account in results.
- 2) Antenna gain(G) : 2.3 dBi,
e.i.r.p.=26.38dBm = 0.435W, which is far below the 4 W

5.1.4 6dB Bandwidth

RESULT:
Pass
Test Specification

Test standard	: FCC Part 15.247(a)(2) RSS-247 Clause 5.2(a)
Basic standard	: ANSI C63.10: 2013
Limits	: At least 500kHz for bandwidth(DTS)
Kind of test site	: Shielded Room

Test Setup

Date of testing	: 2021-06-24
Input voltage	: DC 5V Via USB port
Operation mode	: B
Test channel	: Low / Middle / High
Ambient temperature	: 25 °C
Relative humidity	: 56 %
Atmospheric pressure	: 101 kPa

Note: This test was carried out on right earphone only.

For the measurement records, refer to the appendix B.

Table 9: Test Result of 6dB Bandwidth

Test Mode	Test Channel (MHz)	6dB Bandwidth (MHz)	Limit (MHz)
Lora DTS	903.0	623.0	>500KHz
	907.8	614.3	
	914.2	616.5	
Minimum Measured Value		614.3	

5.1.5 20dB Bandwidth

RESULT:
Pass
Test Specification

Test standard	: FCC Part 15.247(a)(1) (i) RSS-247 Clause 5.1(a)
Basic standard	: ANSI C63.10: 2013 Not more than 500kHz and
Limits	: < 250KHz for at least 50 hopping frequencies >=250KHz for at least 25 hopping frequencies
Kind of test site	: Shielded Room

Test Setup

Date of testing	: 2021-06-24
Input voltage	: DC 5V Via USB port
Operation mode	: A
Test channel	: Low / Middle / High
Ambient temperature	: 25 °C
Relative humidity	: 56 %
Atmospheric pressure	: 101 kPa

Note: This test was carried out on right earphone only.

For the measurement records, refer to the appendix B.

Table 10: Test Result of 20dB Bandwidth

Test Mode	Channel Frequency (MHz)	20dB Bandwidth (kHz)	Limit (MHz)
Lora FHSS	902.3	141.24	<500KHz
	908.5	141.24	
	914.9	141.09	

5.1.6 99% Bandwidth

RESULT:
Pass
Test Specification

Test standard : RSS-Gen Clause 6.7
 Basic standard : ANSI C63.10: 2013
 Kind of test site : Shielded Room

Test Setup

Date of testing : 2021-06-18 - 2021-06-24
 Input voltage : DC 5V Via USB port
 Operation mode : A, B
 Test channel : Low / Middle / High
 Ambient temperature : 25 °C
 Relative humidity : 56 %
 Atmospheric pressure : 101 kPa

Note: This test was carried out on right earphone only.

For the measurement records, refer to the appendix B.

Table 11: Test Result of 99% Bandwidth

Test Mode	Test Channel (MHz)	99% Bandwidth (KHz)	Limit (MHz)
Lora FHSS	902.3	125.90	/
	908.5	126.45	
	914.9	125.36	
Lora DTS	903.0	501.45	
	907.8	503.62	
	914.2	505.79	
Minimum Measured Value		125.36	

5.1.7 Conducted Spurious Emissions Measured in 100 kHz Bandwidth

RESULT:**Pass****Test Specification**

Test standard	: FCC Part 15.247(d) RSS-247 Clause 5.5
Basic standard	: ANSI C63.10: 2013
Limits	: 20dB (below that in the 100kHz bandwidth within the band that contains the highest level of the desired power); In addition, radiated emissions which fall in the restricted bands, must also comply with the radiated emission limits specified in 15.209(a)
Kind of test site	: Shielded Room

Test Setup

Date of testing	: Refer to test result
Input voltage	: DC 5V Via USB port
Operation mode	: A, B
Test channel	: Low / Middle / High
Ambient temperature	: 25 °C
Relative humidity	: 56 %
Atmospheric pressure	: 101 kPa

Test results of 100kHz Bandwidth of Frequency Band Edge by Conducted method refer to test plots, and compliance is achieved as well.

Note: This test was carried out on right earphone only.

For the measurement records, refer to the appendix B.

5.1.8 Radiated Spurious Emission

RESULT:**Pass****Test Specification**

Test standard	:	FCC Part 15.247(d) & FCC Part 15.205 RSS-247 Clause 3.3
Basic standard	:	ANSI C63.10: 2013
Limits	:	Refer to 15.209(a) of FCC part 15.247(d)
Kind of test site	:	3m Semi-anechoic Chamber

Test Setup

Date of testing	:	2021-06-21
Input voltage	:	DC 5V Via USB port
Operation mode	:	A, B
Test channel	:	Low / Middle / High
Ambient temperature	:	Refer to test result
Relative humidity	:	Refer to test result
Atmospheric pressure	:	101 kPa

Remark:

Testing was carried out within frequency range 9kHz to the tenth harmonics. Only the worst case spurious emissions configuration of the each mode were reported.

For the measurement records, refer to the appendix B.

5.1.12 Conducted Emission on AC Mains**RESULT:****Pass****Test Specification**

Test standard	:	FCC Part 15.207(a) RSS-Gen Clause 8.8
Basic standard	:	ANSI C63.10: 2013
Frequency range	:	0.15 – 30MHz
Limits	:	FCC Part 15.207(a) RSS-Gen Table 3
Kind of test site	:	Shielded Room

Test Setup

Date of testing	:	2021-06-22
Input voltage	:	Powered by PC Adapter
Operation mode	:	A, B
Earthing	:	Not connected
Ambient temperature	:	22 °C
Relative humidity	:	64 %
Atmospheric pressure	:	101 kPa

For the measurement records, refer to the appendix B.

6 Safety Human Exposure

6.1 Radio Frequency Exposure Compliance

6.1.1 Electromagnetic Fields

RESULT:**Pass****Test Specification**

Test standard : CFR47 FCC Part 2: Section 2.1091
CFR47 FCC Part 1: Section 1.1310
FCC KDB Publication 447498 v06
FCC KDB Publication 865664 D02 v01r02
OET Bulletin 65 (Edition 97-01)
RSS-102 Issue 5 March 2019

FCC requirement: Systems operating under the provisions of this section shall be operated in a manner that ensures that the public is not exposed to radio frequency energy level in excess limit for maximum permissible exposure. In accordance with 47 CFR FCC Part 2 Subpart J, section 2.1091 this device has been defined as a mobile device whereby a distance of 20cm normally can be maintained between the user and the device.

MPE Calculation Method according to OET Bulletin 65

Power Density: $S_{(mW/cm^2)} = PG/4\pi R^2$ or $EIRP/4\pi R^2$

Where:

S = power density (mW/cm²)

P = power input to the antenna (mW)

G = power gain of the antenna in the direction of interest relative to an isotropic radiator

R = distance to the center of radiation of the antenna (cm)

The nominal maximum conducted output power specified:

Lora FHSS: 20.62 dBm

Lora DTS: 24.08 dBm

From the peak RF output power, the minimum mobile separation distance, d=20 cm, as well as the antenna gain (2.3 dBi Lora FHSS and Lora DTS), the RF power density can be calculated as below:

For Lora FHSS: $S_{(mW/cm^2)} = PG/4\pi R^2 = 0.054$ mW/cm²

For Lora DTS: $S_{(mW/cm^2)} = PG/4\pi R^2 = 0.119$ mW/cm²

Limits for Maximum Permissible Exposure (MPE) according to FCC Part 1.1310: 1.0 mW/cm²

➤ **IC requirements:** The EUT shall comply with the requirement of RSS-102 section 2.5.2.

Exemption from Routine Evaluation Limits – RF Exposure Evaluation

RF exposure evaluation is required if the separation distance between the user and/or bystander and the device's radiating element is greater than 20 cm, except when the device operates as follows:

at or above 300 MHz and below 6 GHz and the source-based, time-averaged maximum e.i.r.p. of the device is equal to or less than $1.31 \times 10^{-2} f^{0.6834}$ W (adjusted for tune-up tolerance), where f is in MHz;

- RF exposure evaluation exempted power for Lora FHSS & DTS: 1.37 W

The nominal maximum conducted output power specified:

Lora FHSS: 20.62 dBm

Lora DTS: 24.08 dBm

Antenna Gain: 2.3 dBi Lora FHSS and Lora DTS

The Max. e.i.r.p. for Lora FHSS: 22.92dBm = 0.196 W

The Max. e.i.r.p. for Lora DTS: 26.38dBm = 0.435 W

Both e.i.r.p. for the Lora FHSS and Lora DTS are less than the RF exposure evaluation exempted power. So RF exposure evaluation is not required.

“RF Radiation Exposure Statement Caution: This Transmitter must be installed to provide a separation distance of at least 20 cm from all persons.”

7 Photographs of the Test Set-Up

For photographs of the test set-up, refer to the appendix A.

8 List of Tables

Table 1: List of Test and Measurement Equipment.....	6
Table 2: Technical Specification of EUT	9
Table 3: RF Channel and Frequency of Lora FHSS.....	10
Table 4: RF Channel and Frequency of Lora DTS.....	10
Table 5: Auxiliary Equipment Used during Test.....	12
Table 6: Test Result of Maximum Peak Conducted Output Power, Lora FHSS	16
Table 7: Test Result of Maximum Peak Conducted Output Power, Lora DTS.....	16
Table 8: Test Result of Maximum Peak Power Spectral Density, Lora DTS.....	17
Table 9: Test Result of 6dB Bandwidth.....	18
Table 10: Test Result of 20dB Bandwidth.....	19
Table 11: Test Result of 99% Bandwidth.....	20
Table 12: Test Result of Carrier Frequency Separation	23
Table 13: Test result of hopping channel number	24
Table 14: Test result of Channel Occupancy	25