



# FCC PART 15.247

## TEST REPORT

For

### Shenzhen Rakwireless Technology Co., Ltd.

Room 506, Bldg B, New Compark, Pingshan First Road Taoyuan Street, XiLi town, Nanshan District, Shenzhen, China

**FCC ID: 2AF6B-RAK2245**

<b>Report Type:</b> Original Report	<b>Product Type:</b> LoRa Concentrator Module
<b>Report Number:</b> RSZ190408005-00B	
<b>Report Date:</b> 2019-04-28	
<b>Reviewed By:</b> Engineer	Xiangguang Kong <i>Xiangguang Kong</i>
<b>Prepared By:</b> Bay Area Compliance Laboratories Corp. (Shenzhen) 6/F., West Wing, Third Phase of Wanli Industrial Building, Shihua Road, Futian Free Trade Zone, Shenzhen, Guangdong, China Tel: +86-755-33320018 Fax: +86-755-33320008 <a href="http://www.baclcorp.com.cn">www.baclcorp.com.cn</a>	

**Note:** This report must not be used by the customer to claim product certification, approval, or endorsement by A2LA\* or any agency of the Federal Government. \* This report may contain data that are not covered by the A2LA accreditation and are marked with an asterisk “\*”.

**TABLE OF CONTENTS**

**GENERAL INFORMATION.....4**

    PRODUCT DESCRIPTION FOR EQUIPMENT UNDER TEST (EUT).....4

    OBJECTIVE.....4

    RELATED SUBMITTAL(S)/GRANT(S).....4

    TEST METHODOLOGY.....4

    MEASUREMENT UNCERTAINTY.....5

    TEST FACILITY.....5

**SYSTEM TEST CONFIGURATION.....6**

    DESCRIPTION OF TEST CONFIGURATION.....6

    EQUIPMENT MODIFICATIONS.....6

    EUT EXERCISE SOFTWARE.....6

    DUTY CYCLE.....7

    LOCAL SUPPORT EQUIPMENT LIST AND DETAILS.....7

    EXTERNAL I/O CABLE.....8

    GPS ANTENNA.....8

    BLOCK DIAGRAM OF TEST SETUP.....8

**SUMMARY OF TEST RESULTS.....9**

**TEST EQUIPMENT LIST.....10**

**FCC §15.247 (I) & §1.1310 & §2.1091- MAXIMUM PERMISSIBLE EXPOSURE (MPE).....11**

    APPLICABLE STANDARD.....11

**FCC §15.203 - ANTENNA REQUIREMENT.....12**

    APPLICABLE STANDARD.....12

    ANTENNA CONNECTOR CONSTRUCTION.....12

**FCC §15.207 (a) – AC LINE CONDUCTED EMISSIONS.....13**

    APPLICABLE STANDARD.....13

    EUT SETUP.....13

    EMI TEST RECEIVER SETUP.....13

    TEST PROCEDURE.....13

    CORRECTED FACTOR & MARGIN CALCULATION.....14

    TEST RESULTS SUMMARY.....14

    TEST DATA.....14

**FCC §15.209, §15.205 & §15.247(d) - SPURIOUS EMISSIONS.....17**

    APPLICABLE STANDARD.....17

    EUT SETUP.....17

    EMI TEST RECEIVER & SPECTRUM ANALYZER SETUP.....18

    TEST PROCEDURE.....18

    CORRECTED AMPLITUDE & MARGIN CALCULATION.....18

    TEST RESULTS SUMMARY.....18

    TEST DATA.....19

**FCC §15.247(a) (2) – 6 dB EMISSION BANDWIDTH.....23**

    APPLICABLE STANDARD.....23

    TEST PROCEDURE.....23

    TEST DATA.....23

**FCC §15.247(b) (3) - MAXIMUM CONDUCTED OUTPUT POWER.....26**  
    APPLICABLE STANDARD .....26  
    TEST PROCEDURE .....26  
    TEST DATA .....26

**FCC §15.247(d) – 100 kHz BANDWIDTH OF FREQUENCY BAND EDGE.....27**  
    APPLICABLE STANDARD .....27  
    TEST PROCEDURE .....27  
    TEST DATA .....27

**FCC §15.247(e) - POWER SPECTRAL DENSITY .....29**  
    APPLICABLE STANDARD .....29  
    TEST PROCEDURE .....29  
    TEST DATA .....29

## GENERAL INFORMATION

### Product Description for Equipment under Test (EUT)

Product	LoRa Concentrator Module
Tested Model	RAK2245
Frequency Range	903-927.5 MHz
Transmit Power	11.73 dBm
Modulation Technique	chirp –based Spread-Spectrum
Antenna Specification	External antenna: 3dBi
Voltage Range	DC 5V
Date of Test	2019/04/18~2019/04/24
Sample serial number	190408005
Received date	2019/04/08
Sample/EUT Status	Good condition

### Objective

This report is prepared on behalf of *Shenzhen Rakwireless Technology Co., Ltd.* in accordance with Part 2-Subpart J, Part 15-Subparts A and C of the Federal Communication Commission's rules.

The tests were performed in order to determine compliance with FCC Part 15, Subpart C, and section 15.203, 15.205, 15.207, 15.209 and 15.247 rules.

### Related Submittal(s)/Grant(s)

No Related Submittal.

### Test Methodology

All measurements contained in this report were conducted with ANSI C63.10-2013, American National Standard of Procedures for Compliance Testing of Unlicensed Wireless Devices.

All emissions measurement was performed at Bay Area Compliance Laboratories Corp. (Shenzhen). The radiated testing was performed at an antenna-to-EUT distance of 3 meters.

## Measurement Uncertainty

Parameter		Uncertainty
Occupied Channel Bandwidth		±5%
RF Output Power with Power meter		±0.73dB
RF conducted test with spectrum		±1.6dB
AC Power Lines Conducted Emissions		±1.95dB
Emissions, Radiated	Below 1GHz	±4.75dB
	Above 1GHz	±4.88dB
Temperature		±1°C
Humidity		±6%
Supply voltages		±0.4%

*Note: Otherwise required by the applicant or Product Regulations, Decision Rule in this report did not consider the uncertainty.*

## Test Facility

The test site used by Bay Area Compliance Laboratories Corp. (Shenzhen) to collect test data is located on the 6/F., West Wing, Third Phase of Wanli Industrial Building, Shihua Road, Futian Free Trade Zone, Shenzhen, Guangdong, China.

The test site has been approved by the FCC under the KDB 974614 D01 and is listed in the FCC Public Access Link (PAL) database, FCC Registration No. : 342867, the FCC Designation No. : CN1221.

The test site has been registered with ISED Canada under ISED Canada Registration Number 3062B.

## SYSTEM TEST CONFIGURATION

---

### Description of Test Configuration

The system was configured for testing in testing mode, which was provided by manufacturer.

For LoRa mode, Detailed Frequency as below:

Channel	Frequency (MHz)	Channel	Frequency (MHz)
1	903	9	923.3
2	904.6	10	923.9
3	906.2	11	924.5
4	907.8	12	925.1
5	909.4	13	925.7
6	911	14	926.3
7	912.6	15	926.9
8	914.2	16	927.5

EUT was tested with Channel 1, 8 and 16.

### Equipment Modifications

No modification was made to the EUT tested.

### EUT Exercise Software

“tftpd32.450” & “XShell” was used to test and the device was tested with the worst case as –s 12 –p 13.

**Duty cycle**

**LoRa Mode**

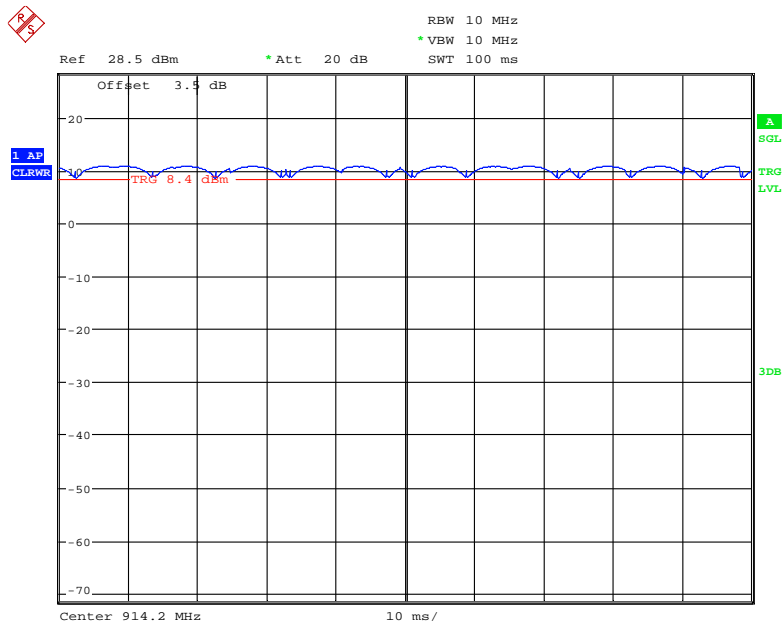

Date: 27.APR.2019 19:08:51

Mode	Duty Cycle (%)	T(us)	1/T(kHz)	VBW Setting	10log(1/x)
LoRa	100	/	/	10Hz	/

**Local Support Equipment List and Details**

Manufacturer	Description	Model	Serial Number
Raspberry Pi	Raspberry Pi 3	Model B+	Un-known
HUAWEI	Adapter	HW-050200A01	Un-known
Un-known	GPS Antenna	Un-known	Un-known
Toshiba	Laptop	C600-C02R	Un-known

**External I/O Cable**

Cable Description	Length (m)	From/Port	To
Un-shield Detachable RJ45 Cable	1.5	Raspberry Pi 3	Laptop
Un-shield Detachable USB Cable	1.0	Adapter	Raspberry Pi 3
Un-shield Un-detachable Singal Cable	1.5	EUT	GPS Antenna
Un-shield Un-detachable RF Cable	0.15	EUT	Lora Ant

**Block Diagram of Test Setup**

For conducted emission

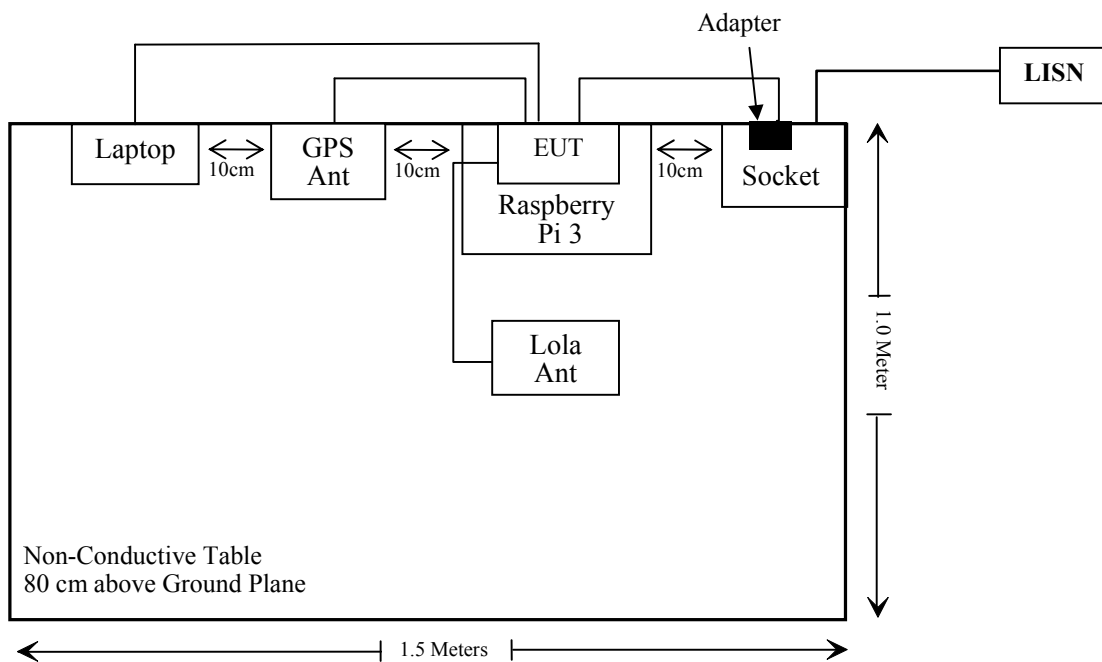



**SUMMARY OF TEST RESULTS**

<b>FCC Rules</b>	<b>Description of Test</b>	<b>Result</b>
§15.247 (i) & §1.1310 & §2.1091	Maximum Permissible exposure (MPE)	Compliance
§15.203	Antenna Requirement	Compliance
§15.207 (a)	AC Line Conducted Emissions	Compliance
§15.205, §15.209, §15.247(d)	Spurious Emissions	Compliance
§15.247 (a)(2)	6 dB Emission Bandwidth	Compliance
§15.247(b)(3)	Maximum Conducted Output Power	Compliance
§15.247(d)	100 kHz Bandwidth of Frequency Band Edge	Compliance
§15.247(e)	Power Spectral Density	Compliance

**TEST EQUIPMENT LIST**

Manufacturer	Description	Model	Serial Number	Calibration Date	Calibration Due Date
<b>Conducted Emissions Test</b>					
Rohde & Schwarz	EMI Test Receiver	ESCS30	100176	2018-07-11	2019-07-11
Rohde & Schwarz	LISN	ENV216	3560.6650.12-101613-Yb	2019-01-25	2020-01-25
Rohde & Schwarz	Transient Limiter	ESH3Z2	DE25985	2019-03-02	2020-03-02
Rohde & Schwarz	CE Test software	EMC 32	V8.53.0	NCR	NCR
Unknown	Conducted Emission Cable	78652	UF A210B-1-0720-504504	2018-11-12	2019-11-12
<b>Radiated Emission Test</b>					
Sunol Sciences	Horn Antenna	DRH-118	A052604	2017-12-22	2020-12-21
Rohde & Schwarz	Signal Analyzer	FSV40	101473	2019-01-09	2020-01-08
COM-POWER	Pre-amplifier	PA-122	181919	2018-11-12	2019-11-12
Sonoma instrument	Amplifier	310 N	186238	2018-11-12	2019-11-12
Sunol Sciences	Broadband Antenna	JB1	A040904-1	2017-12-22	2020-12-21
Rohde & Schwarz	EMI Test Receiver	ESR	1316.3003K03-101746-zn	2018-07-11	2019-07-11
Ducommun technologies	RF Cable	UFA147A-2362-100100	MFR64639231029-003	2018-11-12	2019-11-12
Ducommun technologies	RF Cable	104PEA	218124002	2018-11-12	2019-11-12
Ducommun technologies	RF Cable	RG-214	1	2018-11-19	2019-05-21
Ducommun technologies	RF Cable	RG-214	2	2018-11-12	2019-11-12
Rohde & Schwarz	Auto test software	EMC 32	V9.10	NCR	NCR
<b>RF Conducted Test</b>					
Agilent	Wideband Power Sensor	U2021XA	MY54250003	2018-06-23	2019-06-23
WEINSCHEL	3dB Attenuator	6231	666	Each Time	
Rohde & Schwarz	SPECTRUM ANALYZER	FSU26	200120	2019-03-02	2020-03-01
Ducommun technologies	RF Cable	RG-214	3	Each Time	

\* **Statement of Traceability:** Bay Area Compliance Laboratories Corp. (Shenzhen) attests that all calibrations have been performed in accordance to requirements that traceable to National Primary Standards and International System of Units (SI).

**FCC §15.247 (I) & §1.1310 & §2.1091- MAXIMUM PERMISSIBLE EXPOSURE (MPE)**

**Applicable Standard**

According to subpart 15.247(i) and subpart §1.1310, systems operating under the provisions of this section shall be operated in a manner that ensures that the public is not exposed to radio frequency energy level in excess of the Commission’s guidelines.

Limits for Maximum Permissible Exposure (MPE) (§1.1310, §2.1091)

<b>(B) Limits for General Population/Uncontrolled Exposure</b>				
Frequency Range (MHz)	Electric Field Strength (V/m)	Magnetic Field Strength (A/m)	Power Density (mW/cm <sup>2</sup> )	Averaging Time (minutes)
0.3–1.34	614	1.63	*(100)	30
1.34–30	824/f	2.19/f	*(180/f <sup>2</sup> )	30
30–300	27.5	0.073	0.2	30
300–1500	/	/	f/1500	30
1500–100,000	/	/	1.0	30

f = frequency in MHz; \* = Plane-wave equivalent power density;

According to §1.1310 and §2.1091 RF exposure is calculated.

**Calculated Formulary:**

Predication of MPE limit at a given distance

$S = PG/4\pi R^2$  = power density (in appropriate units, e.g. mW/cm<sup>2</sup>);

P = power input to the antenna (in appropriate units, e.g., mW);

G = power gain of the antenna in the direction of interest relative to an isotropic radiator, the power gain factor, is normally numeric gain;

R = distance to the center of radiation of the antenna (appropriate units, e.g., cm);

**Calculated Data:**

The worst case as below:

Frequency (MHz)	Antenna Gain		Max Tune-up Conducted Power		Evaluation Distance (cm)	Power Density (mW/cm <sup>2</sup> )	MPE Limit (mW/cm <sup>2</sup> )
	(dBi)	(numeric)	(dBm)	(mW)			
903-927.5	3	2	12	15.85	20	0.006	0.6

**Result:** The device meet FCC MPE at 20 cm distance

---

## **FCC §15.203 - ANTENNA REQUIREMENT**

---

### **Applicable Standard**

According to § 15.203, an intentional radiator shall be designed to ensure that no antenna other than that furnished by the responsible party shall be used with the device. The use of a permanently attached antenna or of an antenna that uses a unique coupling to the intentional radiator shall be considered sufficient to comply with the provisions of this section. The manufacturer may design the unit so that a broken antenna can be replaced by the user, but the user of a standard antenna jack or electrical connector is prohibited. The structure and application of the EUT were analyzed to determine compliance with section §15.203 of the rules. §15.203 state that the subject device must meet the following criteria:

- a. Antenna must be permanently attached to the unit.
- b. Antenna must use a unique type of connector to attach to the EUT.

Unit must be professionally installed, and installer shall be responsible for verifying that the correct antenna is employed with the unit.

And according to FCC 47 CFR section 15.247 (b), if the transmitting antennas of directional gain greater than 6dBi are used, the power shall be reduced by the amount in dB that the directional gain of the antenna exceeds 6 dBi.

### **Antenna Connector Construction**

The EUT has an external antenna with a U.FL antenna jack which the maximum antenna gain is 3.0 dBi, fulfill the requirement of this section. Please refer to the EUT photos.

**Result:** Compliance.

**FCC §15.207 (a) – AC LINE CONDUCTED EMISSIONS**

**Applicable Standard**

FCC§15.207

**EUT Setup**

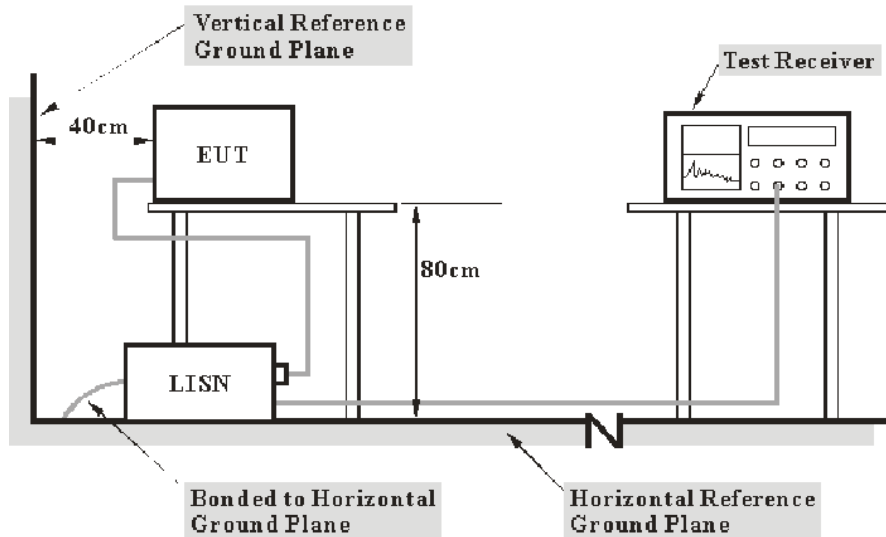

- Note: 1. Support units were connected to second LISN.  
 2. Both of LISNs (AMN) 80 cm from EUT and at the least 80 cm from other units and other metal planes support units.

The setup of EUT is according with per ANSI C63.10-2013 measurement procedure. The specification used was with the FCC Part 15.207 limits.

The spacing between the peripherals was 10 cm.

**EMI Test Receiver Setup**

The EMI test receiver was set to investigate the spectrum from 150 kHz to 30 MHz.

During the conducted emission test, the EMI test receiver was set with the following configurations:

Frequency Range	IF B/W
150 kHz – 30 MHz	9 kHz

**Test Procedure**

During the conducted emission test, the adapter was connected to the outlet of the LISN.

Maximizing procedure was performed on the six (6) highest emissions of the EUT.

All final data was recorded in the Quasi-peak and average detection mode.

## Corrected Factor & Margin Calculation

The Corrected factor is calculated by adding LISN VDF (Voltage Division Factor), Cable Loss and Transient Limiter Attenuation. The basic equation is as follows:

$$\text{Correction Factor} = \text{LISN VDF} + \text{Cable Loss} + \text{Transient Limiter Attenuation}$$

The “**Margin**” column of the following data tables indicates the degree of compliance with the applicable limit. For example, a margin of 7 dB means the emission is 7 dB below the limit. The equation for margin calculation is as follows:

$$\text{Margin} = \text{Limit} - \text{Corrected Amplitude}$$

## Test Results Summary

According to the recorded data in following table, the EUT complied with the FCC Part 15.207,

Refer to CISPR16-4-2:2011 and CISPR 16-4-1:2009, the measured level complies with the limit if

$$L_m + U_{(L_m)} \leq L_{\text{lim}} + U_{\text{cispr}}$$

In BACL,  $U_{(L_m)}$  is less than  $U_{\text{cispr}}$ , if  $L_m$  is less than  $L_{\text{lim}}$ , it implies that the EUT complies with the limit.

## Test Data

### Environmental Conditions

<b>Temperature:</b>	25 °C
<b>Relative Humidity:</b>	50 %
<b>ATM Pressure:</b>	101.0 kPa

*The testing was performed by Haiguo Li on 2019-04-24.*

*EUT operation mode: Transmitting*

**AC 120V/60 Hz, Line**

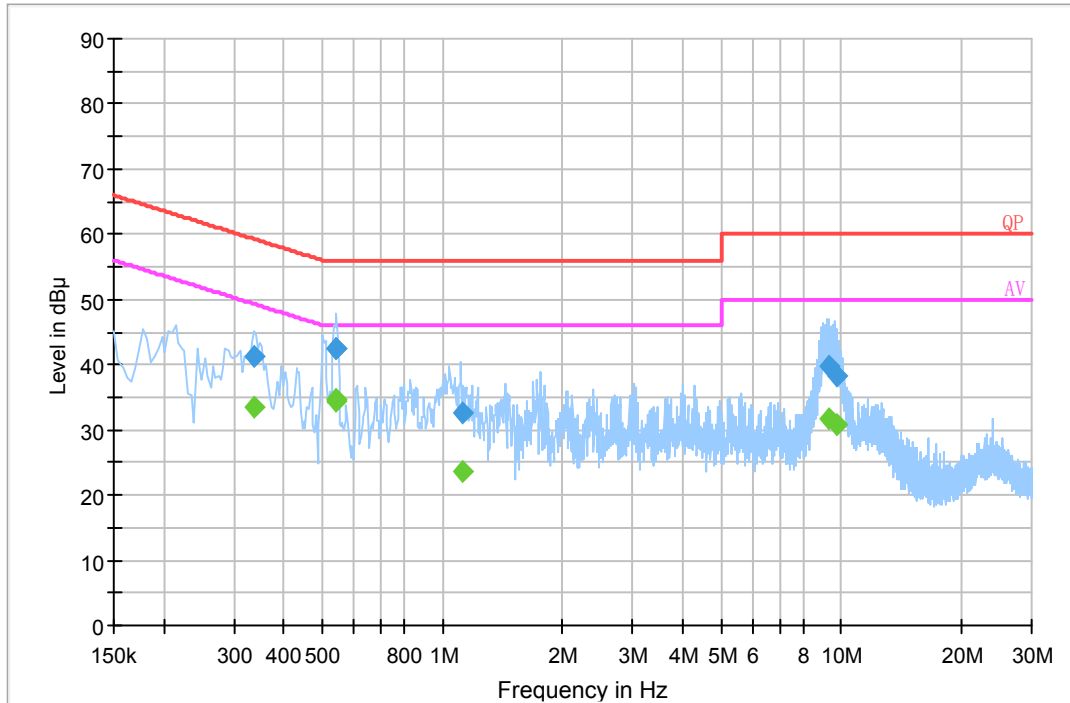

Frequency (MHz)	Corrected Amplitude (dBµV)	Correction Factor (dB)	Limit (dBµV)	Margin (dB)	Detector (PK/Ave./QP)
0.336930	41.3	19.8	59.3	18.0	QP
0.541870	42.6	19.8	56.0	13.4	QP
0.542010	42.4	19.8	56.0	13.6	QP
1.117350	32.5	19.8	56.0	23.5	QP
9.351730	39.9	20.0	60.0	20.1	QP
9.745790	38.4	20.0	60.0	21.6	QP
0.336930	33.6	19.8	49.3	15.7	Ave.
0.541870	34.7	19.8	46.0	11.3	Ave.
0.542010	34.5	19.8	46.0	11.5	Ave.
1.117350	23.7	19.8	46.0	22.3	Ave.
9.351730	31.8	20.0	50.0	18.2	Ave.
9.745790	30.7	20.0	50.0	19.3	Ave.

**AC 120V/60 Hz, Neutral**

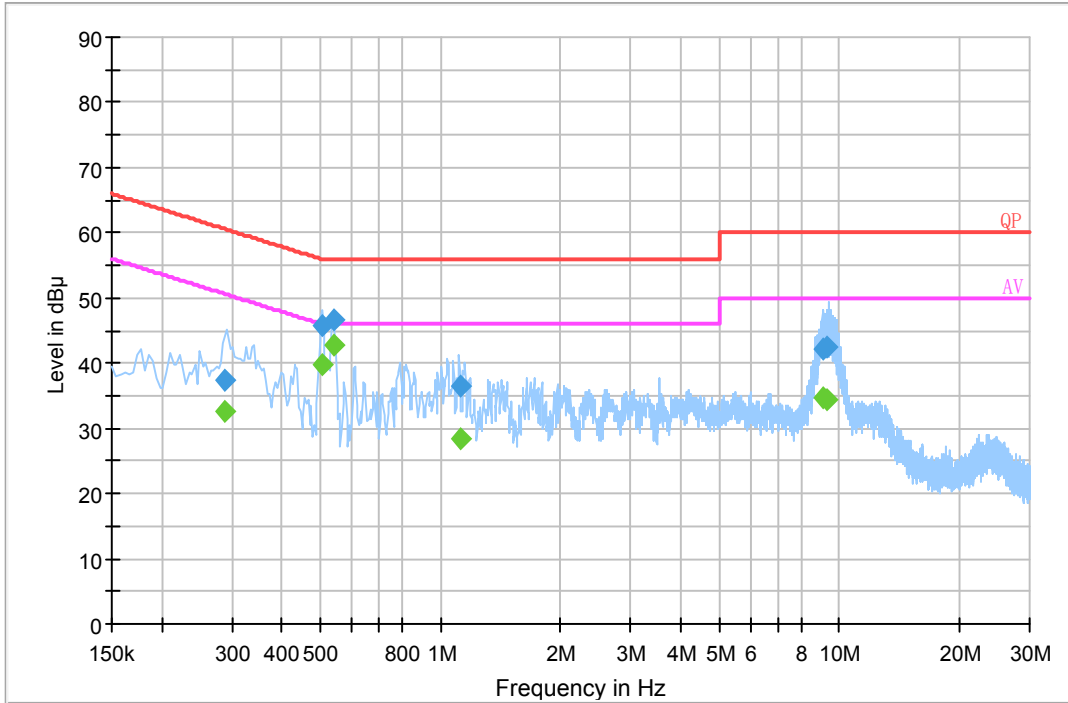

Frequency (MHz)	Corrected Amplitude (dBµV)	Correction Factor (dB)	Limit (dBµV)	Margin (dB)	Detector (PK/Ave./QP)
0.289500	37.4	19.7	60.5	23.1	QP
0.506410	45.9	19.8	56.0	10.1	QP
0.537930	46.5	19.8	56.0	9.5	QP
1.117290	36.4	19.8	56.0	19.6	QP
9.117290	42.3	19.9	60.0	17.7	QP
9.333090	42.6	19.9	60.0	17.4	QP
0.289500	32.5	19.7	50.5	18.1	Ave.
0.506410	39.6	19.8	46.0	6.4	Ave.
0.537930	42.8	19.8	46.0	3.2	Ave.
1.117290	28.5	19.8	46.0	17.5	Ave.
9.117290	34.5	19.9	50.0	15.5	Ave.
9.333090	34.3	19.9	50.0	15.7	Ave.

**Note:**

- 1) Correction Factor = LISN VDF (Voltage Division Factor) + Cable Loss + Transient Limiter Attenuation
- 2) Corrected Amplitude = Reading + Correction Factor
- 3) Margin = Limit - Corrected Amplitude



**FCC §15.209, §15.205 & §15.247(d) - SPURIOUS EMISSIONS**

**Applicable Standard**

FCC §15.247 (d); §15.209; §15.205;

**EUT Setup**

**Below 1 GHz:**

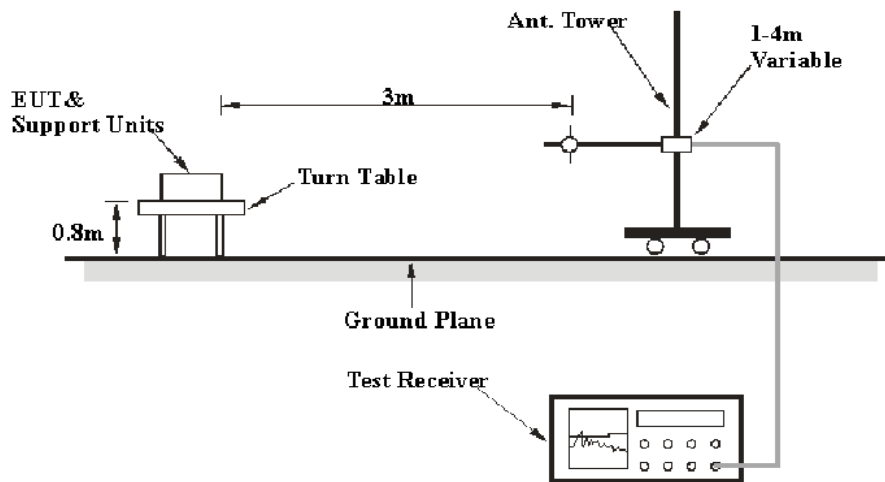

**Above 1GHz:**

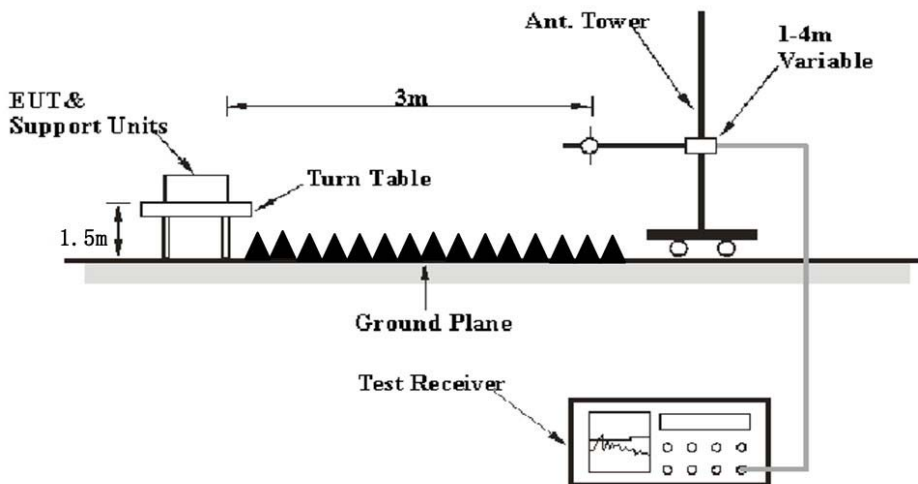

The radiated emission tests were performed in the 3 meters test site, using the setup accordance with the ANSI C63.10-2013. The specification used was the FCC 15.209, and FCC 15.247 limits.

## EMI Test Receiver & Spectrum Analyzer Setup

The system was investigated from 30 MHz to 10 GHz.

During the radiated emission test, the EMI test receiver & Spectrum Analyzer Setup were set with the following configurations:

Frequency Range	RBW	Video B/W	IF B/W	Measurements
30 MHz – 1000 MHz	100 kHz	300 kHz	120 kHz	QP
Above 1 GHz	1MHz	3 MHz	/	PK
	1MHz	10 Hz <sup>Note 1</sup>	/	Average
	1MHz	> 1/T <sup>Note 2</sup>	/	Average

Note 1: when duty cycle is no less than 98%

Note 2: when duty cycle is less than 98%

## Test Procedure

Maximizing procedure was performed on the highest emissions to ensure that the EUT complied with all installation combinations.

Data was recorded in Quasi-peak detection mode for frequency range of 30 MHz-1 GHz, peak and Average detection modes for frequencies above 1 GHz.

## Corrected Amplitude & Margin Calculation

The Corrected Amplitude is calculated by adding the Antenna Factor and Cable Loss, and subtracting the Amplifier Gain from the Meter Reading. The basic equation is as follows:

$$\text{Corrected Amplitude} = \text{Meter Reading} + \text{Antenna Factor} + \text{Cable Loss} - \text{Amplifier Gain}$$

The “**Margin**” column of the following data tables indicates the degree of compliance with the applicable limit. For example, a margin of 7dB means the emission is 7dB below the limit. The equation for margin calculation is as follows:

$$\text{Margin} = \text{Limit} - \text{Corrected Amplitude}$$

## Test Results Summary

According to the recorded data in following table, the EUT complied with the FCC Title 47, Part 15, Subpart C, section 15.205, 15.209 and 15.247.

Refer to CISPR16-4-2:2011 and CISPR 16-4-1:2009, the measured level complies with the limit if

$$L_m + U_{(Lm)} \leq L_{lim} + U_{cispr}$$

In BACL,  $U_{(Lm)}$  is less than  $U_{cispr}$ , if  $L_m$  is less than  $L_{lim}$ , it implies that the EUT complies with the limit.

**Test Data**

**Environmental Conditions**

<b>Temperature:</b>	24~25 °C
<b>Relative Humidity:</b>	55~56 %
<b>ATM Pressure:</b>	101.0~101.2 kPa

The testing was performed by Yooube Zhao and Leo Huang from 2019-04-18 to 2019-04-21.

Test range 30MHz – 10GHz, please refer to the following tables and plots.

**Worst case at Low channel:**

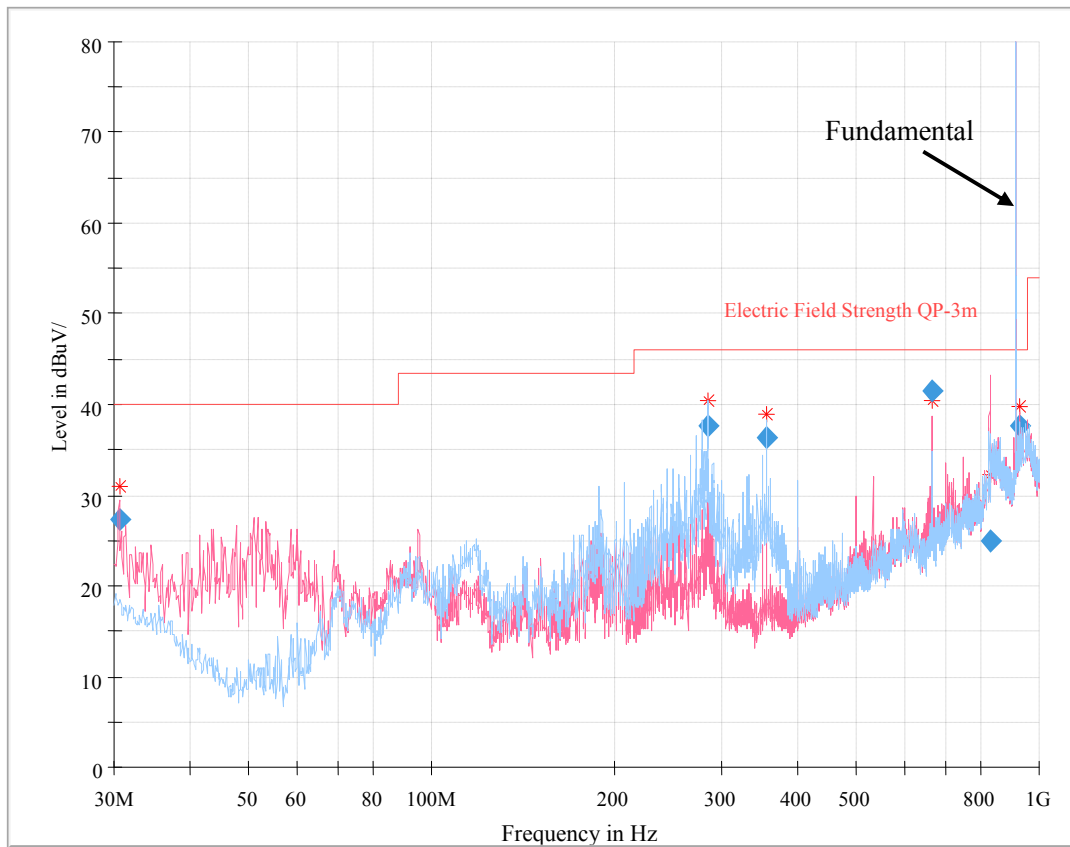

Frequency (MHz)	Corrected Amplitude (dBμV/m)	Antenna height (cm)	Antenna Polarity	Turntable position (degree)	Correction Factor (dB/m)	Limit (dBμV/m)	Margin (dB)
30.616500	27.35	106.0	V	186.0	-8.0	40.00	12.65
284.435125	37.66	108.0	H	176.0	-11.7	46.00	8.34
355.983750	36.43	110.0	H	23.0	-10.8	46.00	9.57
665.004750	41.50	99.0	V	290.0	-2.9	46.00	4.50
828.485500	25.00	393.0	V	140.0	4.8	46.00	21.00
931.006000	37.58	124.0	V	299.0	7.7	46.00	8.42

Frequency (MHz)	Receiver		Turntable Degree	Rx Antenna		Corrected Factor (dB/m)	Corrected Amplitude (dBμV/m)	FCC Part 15.247/205/209	
	Reading (dBμV)	PK/QP/Ave.		Height (m)	Polar (H/V)			Limit (dBμV/m)	Margin (dB)
<b>Low Channel (903 MHz)</b>									
903	98.3	QP	156	2.35	H	4.5	102.8	/	/
903	95.6	QP	135	2.37	V	4.5	100.1	/	/
902	32.9	QP	195	3.25	H	4.4	37.3	82.8	45.5
902	30.4	QP	186	1.52	V	4.4	34.8	80.1	45.3
1806.00	43.44	PK	303	1.2	H	-1.65	41.79	74	32.21
1806.00	30.20	AV	303	1.2	H	-1.65	28.55	54	25.45
1806.00	44.31	PK	266	1.4	V	-1.65	42.66	74	31.34
1806.00	30.22	AV	266	1.4	V	-1.65	28.57	54	25.43
<b>Middle Channel(914.2MHz)</b>									
914.2	90.8	QP	155	1.96	V	5.8	96.6	/	/
914.2	95.6	QP	146	1.86	V	5.8	101.4	/	/
1828.40	43.16	PK	82	2.5	H	-1.55	41.61	74	32.39
1828.40	30.13	AV	82	2.5	H	-1.55	28.58	54	25.42
1828.40	44.25	PK	284	1.2	V	-1.55	42.70	74	31.30
1828.40	30.42	AV	284	1.2	V	-1.55	28.87	54	25.13
<b>High Channel(927.5 MHz)</b>									
927.5	93	QP	186	1.35	H	7.3	100.3	/	/
927.5	93.1	QP	165	2.37	V	7.3	100.4	/	/
928	44.6	QP	135	1.25	H	7.4	52	80.3	28.3
928	44.4	QP	116	3.52	V	7.4	51.8	80.4	28.6
1855.00	43.64	PK	223	1.3	H	-1.16	42.48	74	31.52
1855.00	30.16	AV	223	1.3	H	-1.16	29.00	54	25.00
1855.00	44.53	PK	139	1.2	V	-1.16	43.37	74	30.63
1855.00	31.26	AV	139	1.2	V	-1.16	30.10	54	23.90

**Note:**

Corrected Factor = Antenna factor (RX) + Cable Loss – Amplifier Factor

Corrected Amplitude = Corrected Factor + Reading

Margin = Limit - Corrected. Amplitude

The other spurious emission which is 20dB to the limit was not recorded.

### Pre-scan with High channel for Peak Horizontal

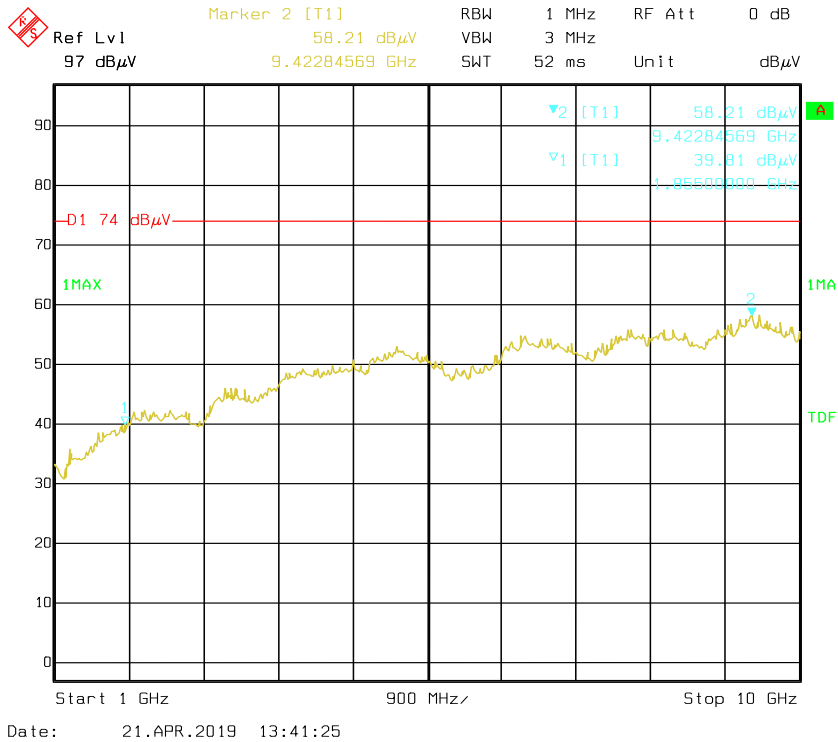

### Vertical

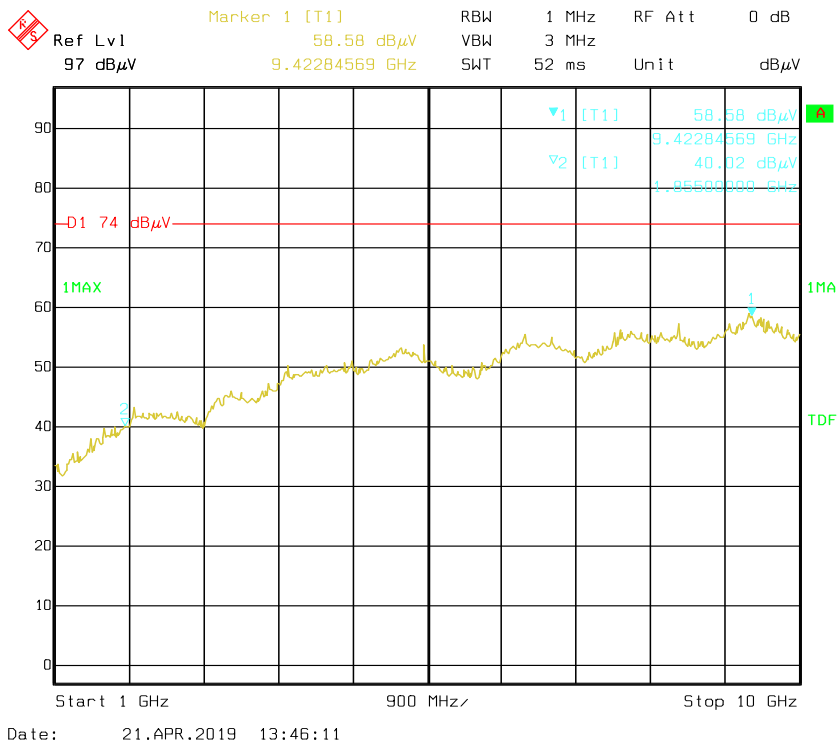

### Average Horizontal

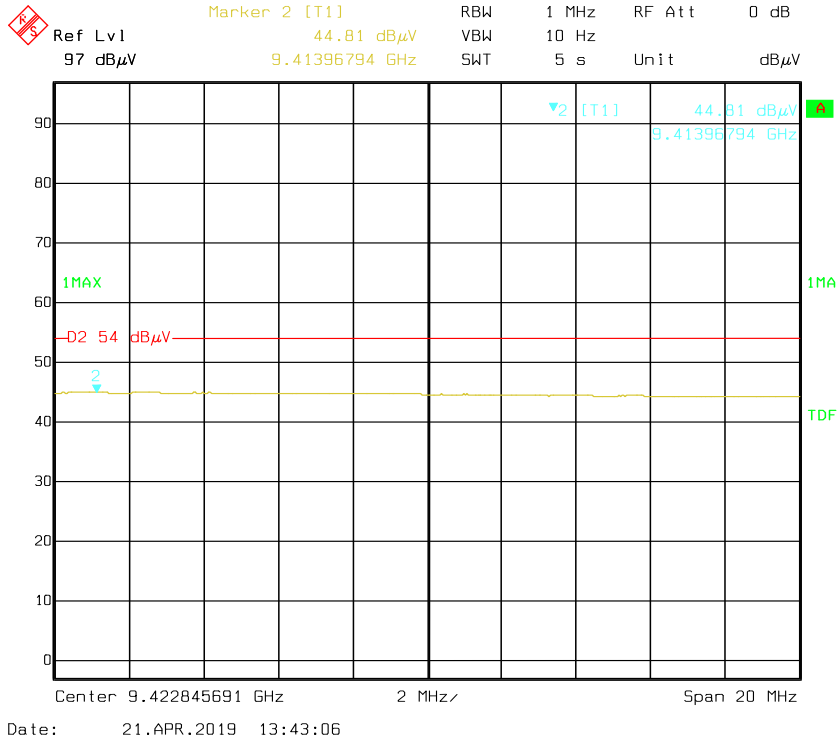

### Vertical

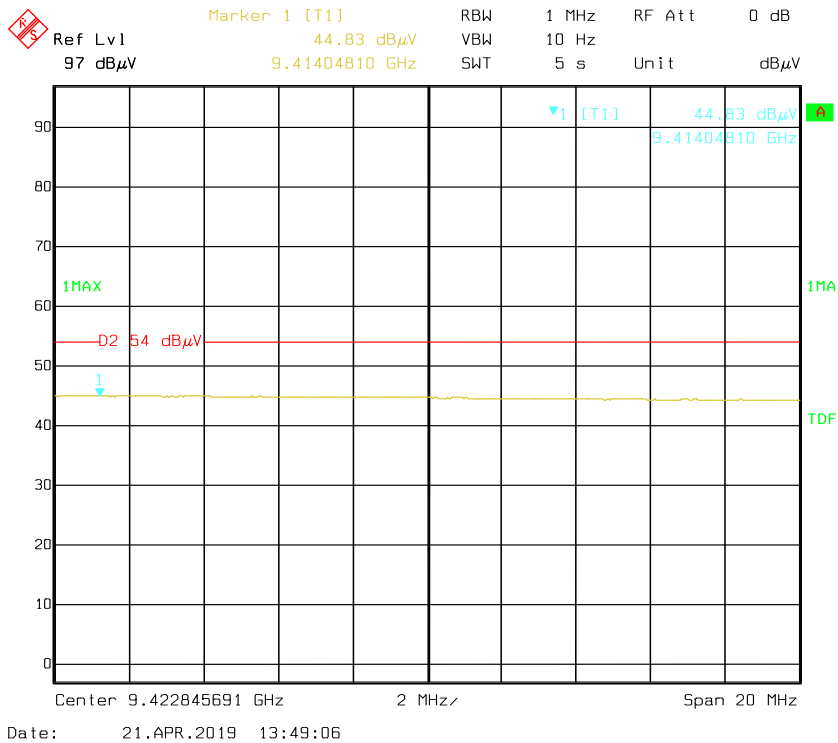

**FCC §15.247(a) (2) – 6 dB EMISSION BANDWIDTH**

**Applicable Standard**

Systems using digital modulation techniques may operate in the 902–928 MHz, 2400–2483.5 MHz, and 5725–5850 MHz bands. The minimum 6 dB bandwidth shall be at least 500 kHz.

**Test Procedure**

1. Check the calibration of the measuring instrument using either an internal calibrator or a known signal from an external generator.
2. Position the EUT without connection to measurement instrument. Turn on the EUT and connect it to measurement instrument. Then set it to any one convenient frequency within its operating range. Set a reference level on the measuring instrument equal to the highest peak value.
3. Measure the frequency difference of two frequencies that were attenuated 6 dB from the reference level. Record the frequency difference as the emission bandwidth.
4. Repeat above procedures until all frequencies measured were complete.

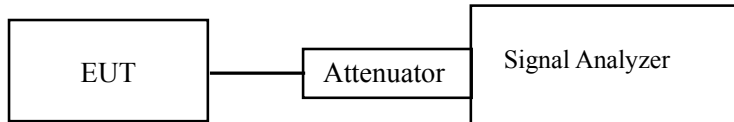

**Test Data**

**Environmental Conditions**

<b>Temperature:</b>	25 °C
<b>Relative Humidity:</b>	52 %
<b>ATM Pressure:</b>	101.0 kPa

*The testing was performed by George Zhong on 2019-04-18.*

**Test Result:** Pass.

Please refer to the following table and plots.

EUT operation mode: Transmitting

Channel	Frequency (MHz)	6 dB Emission Bandwidth (kHz)	Limit (kHz)
Low	903	0.590	≥500
Middle	914.2	0.606	≥500
High	927.5	0.603	≥500

Low Channel

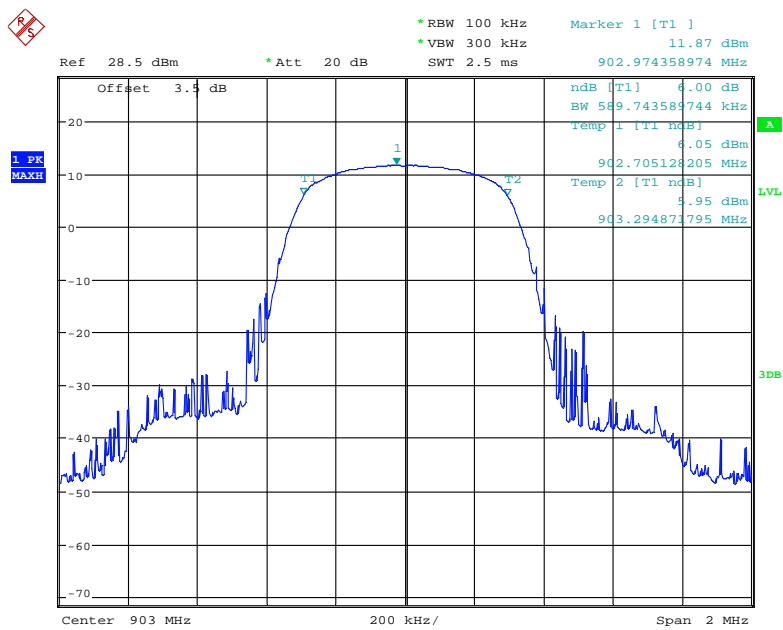

Date: 18.APR.2019 17:15:37



### Middle Channel

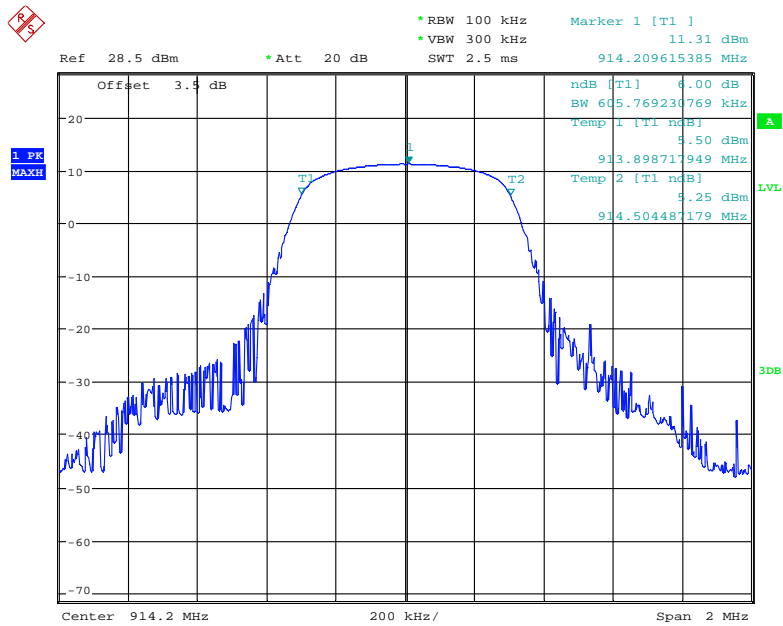

Date: 18.APR.2019 17:14:51

### High Channel

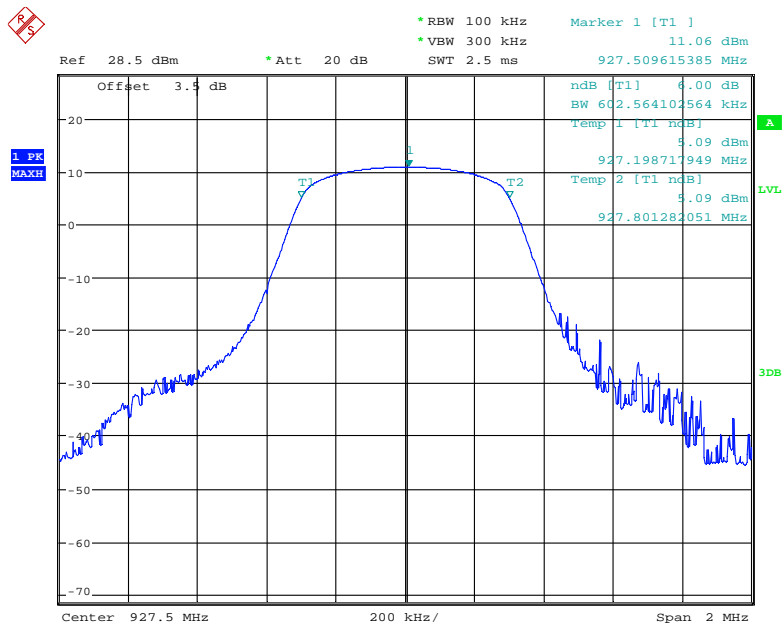

Date: 18.APR.2019 17:13:45

## FCC §15.247(b) (3) - MAXIMUM CONDUCTED OUTPUT POWER

### Applicable Standard

According to FCC §15.247(b) (3), for systems using digital modulation in the 902-928 MHz, 2400-2483.5 MHz, and 5725-5850 MHz bands: 1 Watt. As an alternative to a peak power measurement, compliance with the one Watt limit can be based on a measurement of the maximum conducted output power.

Maximum Conducted Output Power is defined as the total transmit power delivered to all antennas and antenna elements averaged across all symbols in the signaling alphabet when the transmitter is operating at its maximum power control level. Power must be summed across all antennas and antenna elements. The average must not include any time intervals during which the transmitter is off or is transmitting at a reduced power level. If multiple modes of operation are possible (e.g., alternative modulation methods), the maximum conducted output power is the highest total transmit power occurring in any mode.

### Test Procedure

1. Place the EUT on a bench and set it in transmitting mode.
2. Remove the antenna from the EUT and then connect a low loss RF cable from the antenna port to one test equipment.
3. Add a correction factor to the display.

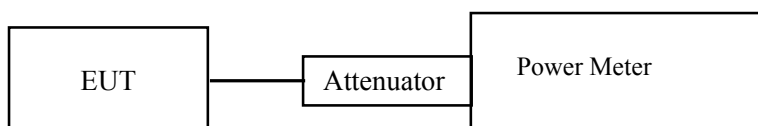

### Test Data

#### Environmental Conditions

<b>Temperature:</b>	25 °C
<b>Relative Humidity:</b>	52 %
<b>ATM Pressure:</b>	101.0 kPa

*The testing was performed by George Zhong on 2018-04-18.*

*EUT operation mode: Transmitting*

Channel	Frequency (MHz)	Peak Output Power (dBm)	Limit (dBm)
Low	903	11.73	30
Middle	914.2	11.43	30
High	927.5	11.39	30

**FCC §15.247(d) – 100 kHz BANDWIDTH OF FREQUENCY BAND EDGE**

**Applicable Standard**

In any 100 kHz bandwidth outside the frequency band in which the spread spectrum or digitally modulated intentional radiator is operating, the radio frequency power that is produced by the intentional radiator shall be at least 20 dB below that in the 100 kHz bandwidth within the band that contains the highest level of the desired power, based on either an RF conducted or a radiated measurement, provided the transmitter demonstrates compliance with the peak conducted power limits. If the transmitter complies with the conducted power limits based on the use of RMS averaging over a time interval, as permitted under paragraph (b)(3) of this section, the attenuation required under this paragraph shall be 30 dB instead of 20 dB. Attenuation below the general limits specified in §15.209(a) is not required. In addition, radiated emissions which fall in the restricted bands, as defined in §15.205(a), must also comply with the radiated emission limits specified in §15.209(a) (see §15.205(c)).

**Test Procedure**

1. Check the calibration of the measuring instrument using either an internal calibrator or a known signal from an external generator.
2. Position the EUT without connection to measurement instrument. Turn on the EUT and connect its antenna terminal to measurement instrument via a low loss cable. Then set it to any one measured frequency within its operating range, and make sure the instrument is operated in its linear range.
3. Set RBW to 100 kHz and VBW of spectrum analyzer to 300 kHz with a convenient frequency span including 100 kHz bandwidth from band edge.
4. Measure the highest amplitude appearing on spectral display and set it as a reference level. Plot the graph with marking the highest point and edge frequency.
5. Repeat above procedures until all measured frequencies were complete.

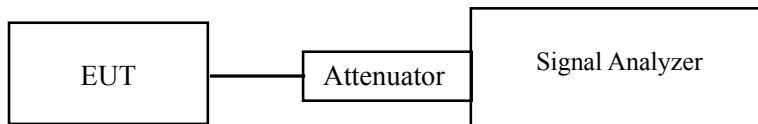

**Test Data**

**Environmental Conditions**

<b>Temperature:</b>	25 °C
<b>Relative Humidity:</b>	52 %
<b>ATM Pressure:</b>	101.0 kPa

*The testing was performed by George Zhong on 2018-04-18.*

*EUT operation mode: Transmitting*

**Test Result:** Compliance

Please refer to the following plots.

### Band Edge, Left Side

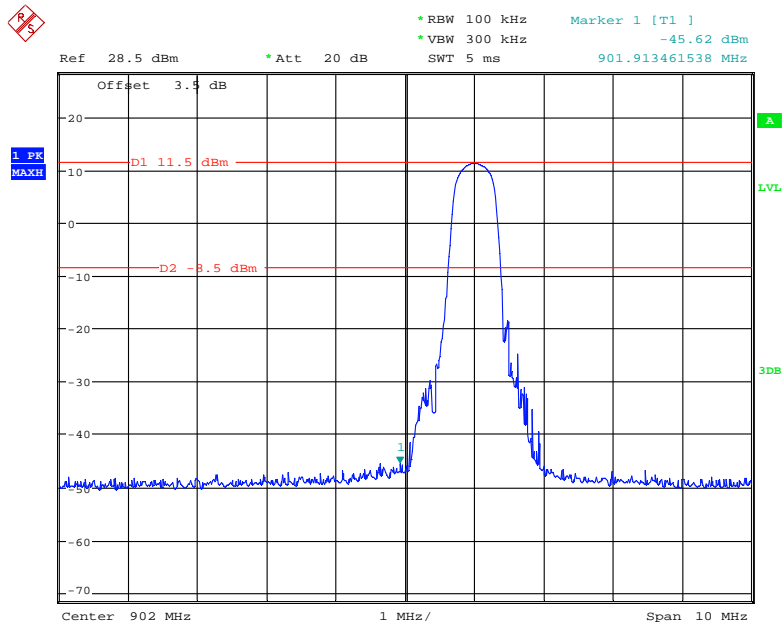

Date: 18.APR.2019 16:27:33

### Band Edge, Right Side

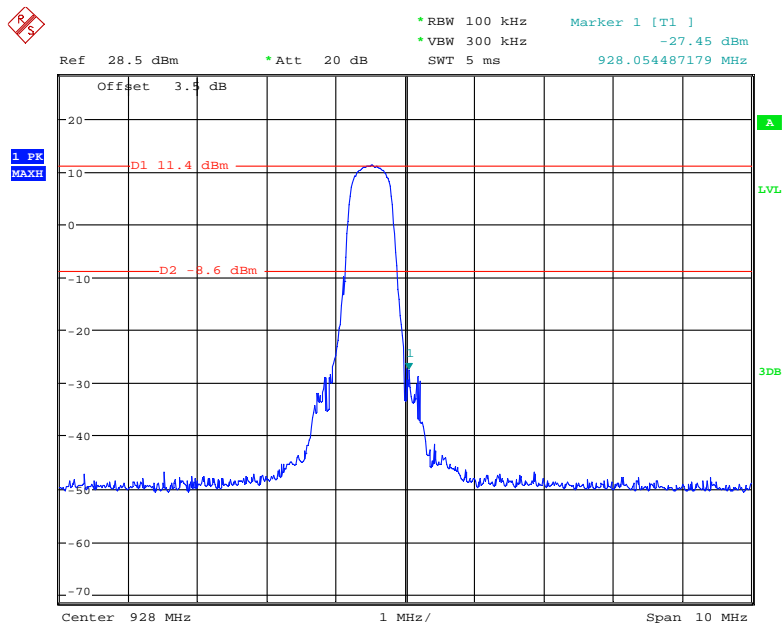

Date: 18.APR.2019 16:31:47

## FCC §15.247(e) - POWER SPECTRAL DENSITY

### Applicable Standard

For digitally modulated systems, the power spectral density conducted from the intentional radiator to the antenna shall not be greater than 8 dBm in any 3 kHz band during any time interval of continuous transmission. This power spectral density shall be determined in accordance with the provisions of paragraph (b) of this section. The same method of determining the conducted output power shall be used to determine the power spectral density.

### Test Procedure

1. Use this procedure when the maximum peak conducted output power in the fundamental emission is used to demonstrate compliance.
2. Set the RBW to:  $3\text{kHz} \leq \text{RBW} \leq 100\text{ kHz}$ .
3. Set the VBW  $\geq 3 \times \text{RBW}$ .
4. Set the span to 1.5 times the DTS bandwidth.
5. Detector = peak.
6. Sweep time = auto couple.
7. Trace mode = max hold.
8. Allow trace to fully stabilize.
9. Use the peak marker function to determine the maximum amplitude level within the RBW.
10. If measured value exceeds limit, reduce RBW (no less than 3 kHz) and repeat.

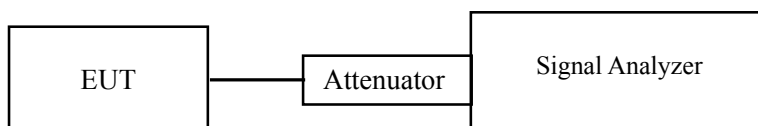

### Test Data

#### Environmental Conditions

<b>Temperature:</b>	25 °C
<b>Relative Humidity:</b>	52 %
<b>ATM Pressure:</b>	101.0 kPa

The testing was performed by George Zhong on 2018-04-18.

EUT operation mode: Transmitting

**Test Result:** Pass

Channel	Frequency (MHz)	PSD (dBm/3kHz)	Limit (dBm/3kHz)
Low	903	7.47	≤8
Middle	914.2	7.01	≤8
High	927.5	7.13	≤8

### Power Spectral Density, Low Channel

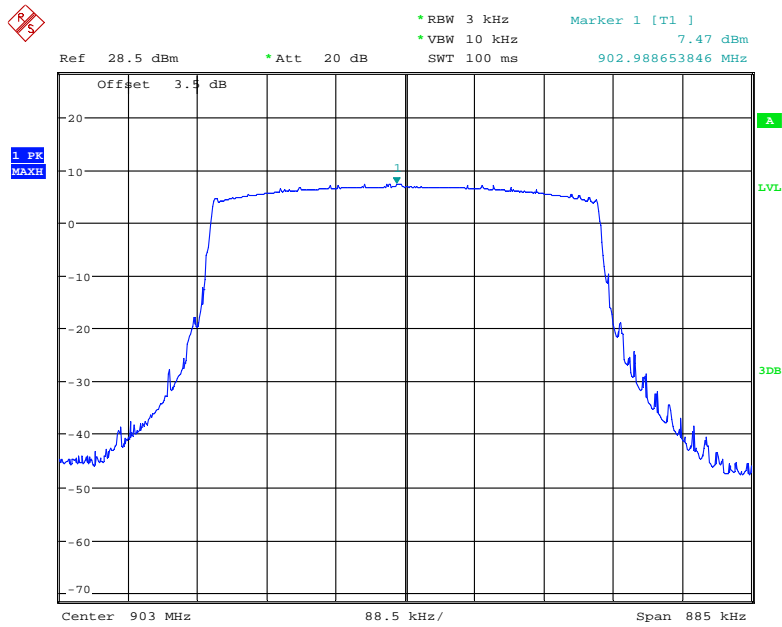

Date: 18.APR.2019 17:22:36

### Power Spectral Density, Middle Channel

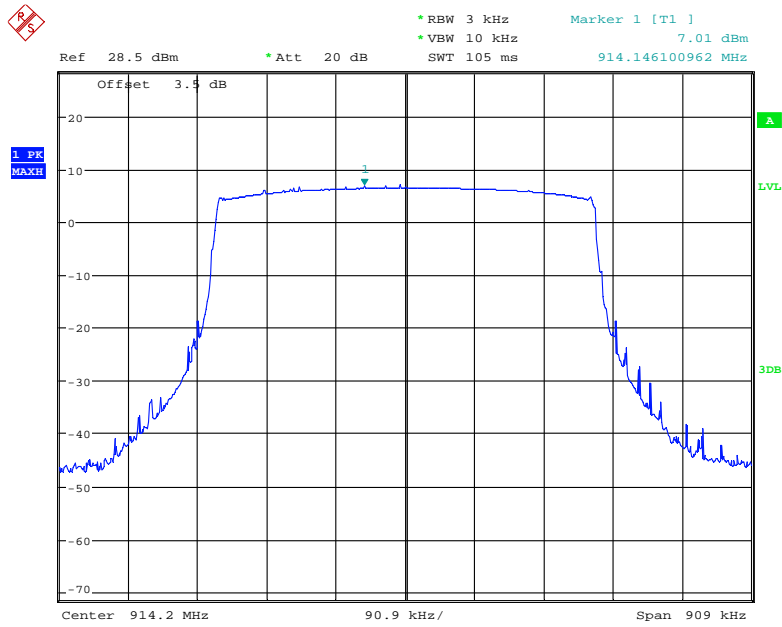

Date: 18.APR.2019 17:25:02

### Power Spectral Density, High Channel

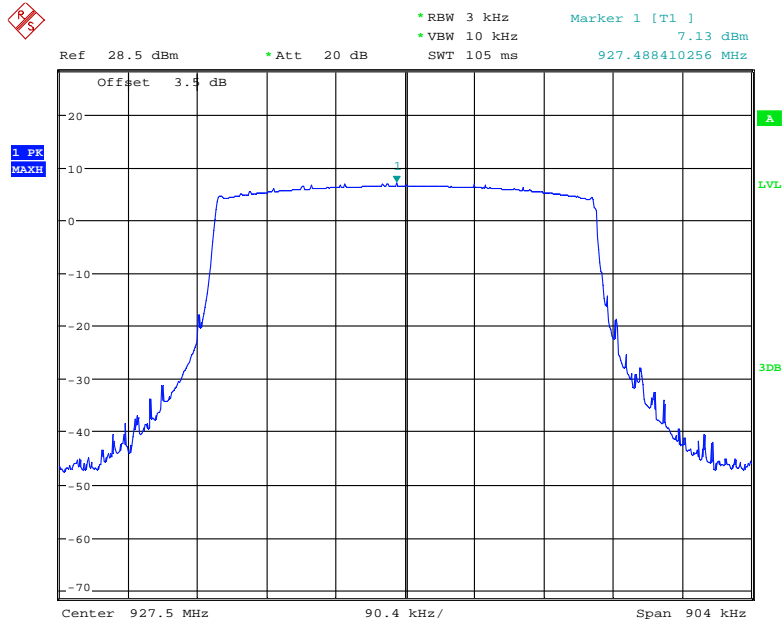

Date: 18.APR.2019 17:27:02

\*\*\*\*\* END OF REPORT \*\*\*\*\*